

MSC-01372-2

SQT



NATIONAL AERONAUTICS AND SPACE ADMINISTRATION
N73-73947

(NASA-TM-X-69515) APOLLO OPERATIONS
HANDBOOK EXTRAVEHICULAR MOBILITY UNIT.
VOLUME 2: OPERATIONAL PROCEDURES
CSD-A-789-(2), APOLLO 15-17, REVISION 3
(NASA) 138 p

Unclas
00/99 18140

APOLLO OPERATIONS HANDBOOK EXTRAVEHICULAR MOBILITY UNIT

JUNE 1971

VOLUME II
OPERATIONAL PROCEDURES

CSD-A-789-(2)

APOLLO 15-17



CREW SYSTEMS DIVISION

ORIGINAL ISSUE MAY 1969

REVISION III

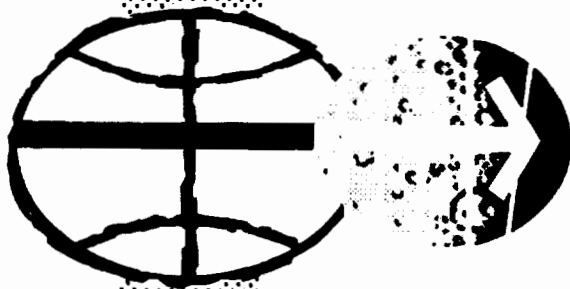

MANNED SPACECRAFT CENTER
HOUSTON, TEXAS

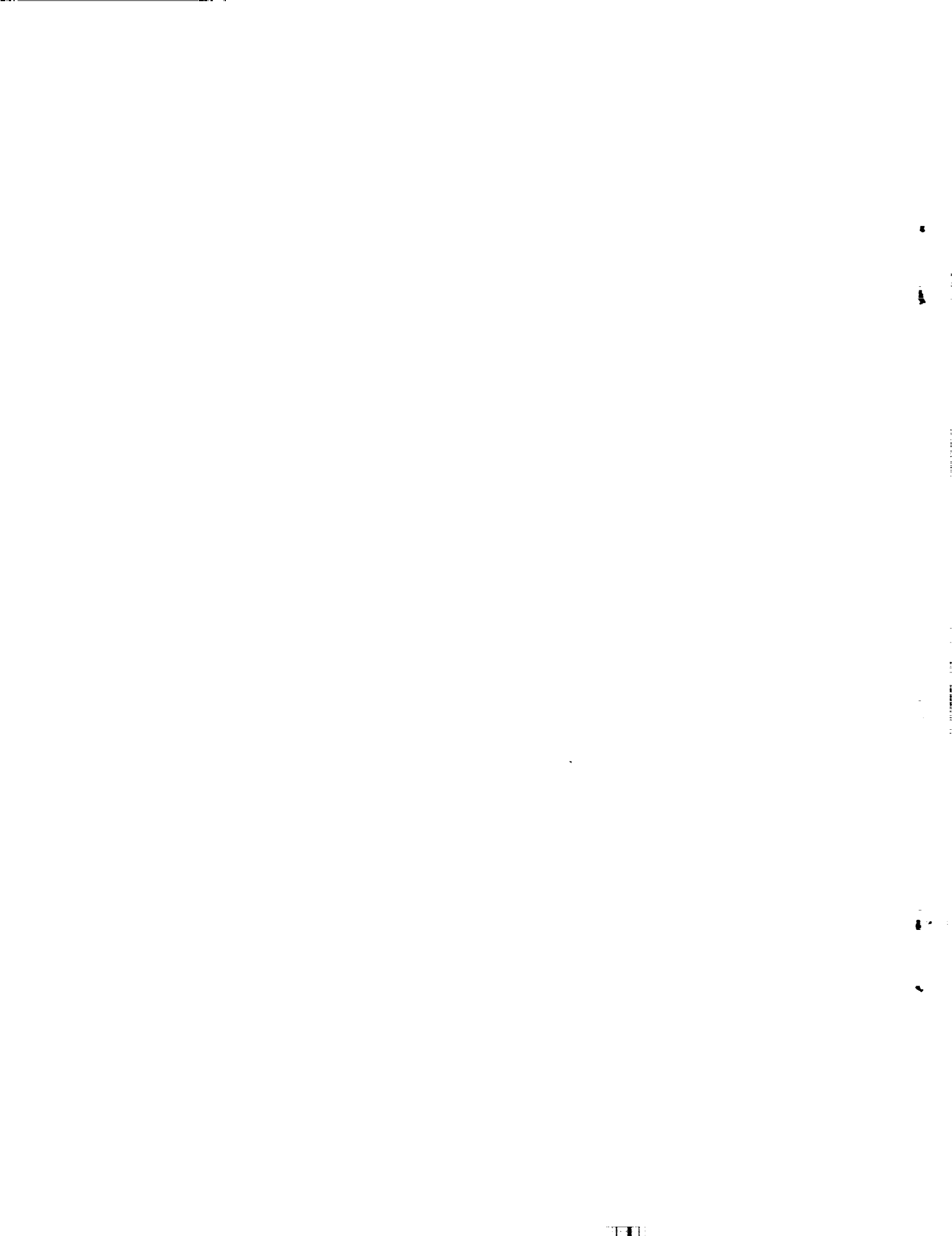

PROJECT DOCUMENT COVER SHEET

APOLLO OPERATIONS HANDBOOK EXTRAVEHICULAR MOBILITY UNIT VOLUME II — OPERATIONAL PROCEDURES	
CSD CSD-A-789-(2) III	DATE May 1969

PREPARED BY:	<i>James L. Gibson</i> 5/16/69 James L. Gibson, Apollo Support Branch
APPROVED:	<i>Charles C. Lutz</i> 5/16/69 Charles C. Lutz, Chief <small>(BRANCH)</small>
APPROVED:	<i>Robert E. Smylie</i> Robert E. Smylie, Chief, CSD <small>(DIVISION)</small>
APPROVED:	<i>David C. Smylie</i> 7/4/71 David C. Smylie <small>(CREW PROCEDURES DIVISION, EVALVA BRANCH, FPO)</small>

NO. OF PAGES 136

		REVISIONS			
DATE	PREPARED BY	APPROVALS			REV. LETTER
		BRANCH	DIVISION	PROGRAM OFFICE	
Oct. 69	J. L. Gibson				Rev. I
Sept 70	<i>J. L. Gibson</i> 10/12 J. L. Gibson				Rev. II
June 71	<i>J. D. Gibson</i> 7/1 J. D. Gibson				Rev. III

CSD
 CSD-A-789-(2) III



**PROJECT DOCUMENT CHANGE/REVISION LOG
FOR CSD ORIGINATED DOCUMENT
NUMBER CSD-A-789(2) III**

PAGE ii OF ix

CHG. NO. / DATE	AUTHORITY FOR CHANGE	PAGES AFFECTED	BRIEF DESCRIPTION OF CHANGE	END ITEM/ SERIAL NUMBER AFFECTED
Rev. III	EMU 77A 77A 7/1 through 88A	All	Reorganized and rewritten to accommodate A7LB suit configuration and the - 7 PLSS configuration	Apollo 15

ALTERED PAGES MUST BE TYPED & DISTRIBUTED FOR INSERTION

CSD-A-789-(2) III
APOLLO OPERATIONS HANDBOOK - EMU

CONTENTS

Section	Page
4. <u>OPERATIONAL PROCEDURES</u>	4-1
4.1 PGA DONNING AND DOFFING	4-2
4.1.1 PGA Donning Procedures Before IV Use	4-2
4.1.2 PGA Doffing Procedures After IV Use	4-15
4.1.3 PGA Donning Procedures Before EV Use	4-20
4.1.4 PGA Doffing Procedures After EV Use	4-25
4.2 OPS OPERATIONS	4-29
4.2.1 OPS Checkout	4-29
4.2.2 OPS Donning Prior to Contingency Transfer	4-29
4.2.3 OPS Donning Before CMP EVA	4-30
4.2.4 OPS Activation	4-32
4.2.5 OPS Deactivation	4-32
4.2.6 OPS Doffing After CMP EVA	4-32
4.3 PLSS/OPS DONNING AND DOFFING	4-33
4.3.1 PLSS/OPS Donning	4-33
4.3.2 PLSS/OPS Doffing in Pressurized Environment	4-36
4.3.3 PLSS/OPS Doffing in Unpressurized Environment	4-40
4.4 PLSS COMMUNICATIONS CHECK	4-45
4.5 PRESSURE INTEGRITY CHECK	4-47
4.6 PLSS NORMAL OPERATING MODES	4-49
4.6.1 PLSS Activation	4-49
4.6.2 Wet Sublimator Restart	4-50
4.6.3 PLSS Deactivation	4-50
4.7 PLSS RECHARGE AND FEEDWATER REMOVAL PROCEDURES	4-52
4.7.1 Battery Replacement	4-52

CSD-A-789-(2) III
APOLLO OPERATIONS HANDBOOK - EMU

Section	Page
4.7.2 Removal of LiOH Cartridge From Stowage Container	4-53
4.7.3 LiOH Cartridge Change	4-54
4.8 PURGE VALVE OPERATION	4-56
4.8.1 Activation Procedures for Purge Valve	4-56
4.8.2 Flow Adjustment Procedures	4-56
4.8.3 Shutoff Procedures	4-56
4.8.4 Purge Valve Removal Procedures	4-57
4.9 PRESSURE CONTROL VALVE OPERATION	4-58
4.9.1 PCV Installation	4-58
4.9.2 PCV Activation	4-58
4.9.3 PCV Deactivation	4-58
4.9.4 PCV Removal Procedures	4-58
4.10 EMU INFLIGHT MAINTENANCE	4-59
4.10.1 PGA and LEVA Inflight Examination and Maintenance	4-59
4.10.2 Bioinstrumentation Inflight Repair	4-64
4.11 MISCELLANEOUS PROCEDURES	4-66
4.11.1 PLSS Gas Trap Activation	4-66
4.11.2 Camera Mounting on RCU	4-67
4.11.3 BSLSS Bag to PLSS Donning	4-68
4.11.4 BSLSS Bag to PLSS Doffing	4-68
4.11.5 BSLSS Stowage on LRV	4-68
4.11.6 BSLSS Donning and Activation Procedure	4-69
4.11.7 BSLSS Disconnect Procedure	4-69
4.11.8 Donning and Doffing Helmet Shield	4-70
4.11.9 Donning and Doffing Neck Dam	4-70
4.11.10 Insuit Drinking Device (ISDD) Installation and Use	4-71

CSD-A-789-(2) III
APOLLO OPERATIONS HANDBOOK - EMU

Section	Page
4.11.11 OPS Oxygen Usage for Metabolic Makeup — LM and CM	4-74
4.11.12 OPS Bleed Down — LM and CM	4-74
5. <u>EMU MALFUNCTION PROCEDURES FOR LUNAR SURFACE EVA</u>	5-1
5.1 INTRODUCTION	5-1
5.2 FORMAT OF MALFUNCTION PROCEDURES	5-1
5.3 MALFUNCTION SYMPTOMS FOR EMU USING PLSS SV 706100-7	5-3

CSD-A-789-(2) III
APOLLO OPERATIONS HANDBOOK - EMU

ABBREVIATIONS

acfm	actual cubic feet per minute
AOH	Apollo Operations Handbook
BSLSS	Buddy Secondary Life Support System
CDR	Commander
cfm	cubic feet per minute
CM	command module
CMP	command module pilot
comm	communications
CSM	command/service module
CWG	constant wear garment
"DES" H ₂ O	descent water
ECG	electrocardiogram
ECS	environmental control system
EMU	extravehicular mobility unit
EV	extravehicular
ISDD	insuit drinking device
LEVA	lunar extravehicular visor assembly
FCS	fecal containment system
ITMG	integrated thermal micrometeoroid garment
IV	intravehicular
IVA	intravehicular activity
kHz	kilohertz (thousand cycles per second)
LCG	liquid cooling garment
LiOH	lithium hydroxide
LM	lunar module
MSFN	Manned Space Flight Network

CSD -A-789-(2) III
APOLLO OPERATIONS HANDBOOK - EMU

OPS	oxygen purge system
PGA	pressure garment assembly
PHA	pressure helmet assembly
PLSS	portable life support system
pos.	position
POS	primary oxygen system of PLSS
press.	pressure
psia	pounds per square inch absolute
psid	pounds per square inch differential
psig	pounds per square inch gage
PTT	push to talk
RCU	remote control unit
rcvr	receiver
SC	spacecraft
sel.	selector
SSC	space suit communication
SW.	switch
TLSA	torso limb suit assembly
TM	telemetry
UCTA	urine collection and transfer assembly
UTS	urine transfer system
vlv	valve
VOX	voice operated transmitter
WMS	waste management system
xducer	transducer
xmtr	transmitter
ZPN	impedance pneumograph

CSD-A-789-(2) III
APOLLO OPERATIONS HANDBOOK - EMU

ΔT change in temperature

ΔP change in pressure

CSD-A-789-(2) III
APOLLO OPERATIONS HANDBOOK - EMU

FOREWORD

This handbook, sections 4 and 5, of the Apollo Operations Handbook (AOH) series, is bound separately as Volume II and pertains only to the Extravehicular Mobility Unit (EMU). Volume I of the AOH contains sections 1, 2, and 3, and pertains to the description of the EMU.

The operational procedures are written specifically for Apollo J-mission EMU hardware and will be superseded by a mission-oriented checklist which is reviewed by Crew Systems Division (CSD) for unique hardware procedures. Both the operational procedures and the malfunction procedures will be updated for the mission.

This handbook is composed of two major sections:

- a. Section 4 provides a step-by-step operational procedure for activation and deactivation of EMU subsystems.
- b. Section 5 provides emergency procedures for critical EMU symptoms and continuing diagnosis during EVA and post-EVA to determine the EMU malfunction (to be supplied).

Insuiries concerning this handbook should be addressed to Crew Systems Division, Systems Engineering Branch, MSC, mail code EC2 or to Crew Procedures Division, EVA/IVA Procedures Branch, mail code CG3.

SECTION 4

OPERATIONAL PROCEDURES

This section includes the procedures for activation and deactivation of the EMU equipment. Techniques in donning may vary within an individual step, but the sequence of the steps outlined should not be changed.

STEP	PROCEDURE	REMARKS
4.1	PGA DONNING AND DOFFING	The comfort gloves and wristlets are provided as crew preference items and may be donned and doffed as convenient to the wearer.
4.1.1	<u>PGA Donning Procedures Before IV Use</u>	If the bioinstrumentation system is required, shave electrode sites where necessary and shower after shaving. Placement of biomedical sensors or electrodes shall be done under medical direction (see note).
4.1.1.1	Donning FCS	
a.	Don FCS as conventional underwear, and place genitals through front opening.	
b.	Position FCS around waist and thighs to insure a seal. Ensure a snug fit with no sag in the crotch portion of the FCS.	
4.1.1.2	Donning Bioinstrumentation and CWG	The steps that prescribe the installation of the bioinstrumentation may be skipped when their use is not required (Steps d., e., and h. through k; see note).
a.	Open front buttons of CWG.	
b.	Don CWG to waist as conventional long underwear.	
c.	Adjust feet into integrated socks.	
d.	Clean shaved electrode sites with alcohol and let dry.	NOTE: Initial placement of biomedical sensors and electrodes is a pre-flight procedure.

STEP	PROCEDURE	REMARKS
<p>e. Assemble signal conditioners, biomedical harness with biomedical belt, and test as a system.</p> <p>f. Insert bioinstrumentation leads through slots on chest area of CWG. Don top half of CWG, and insert harness connectors (blue and yellow) through holes in CWG. Snap biomedical belt to CWG.</p> <p>g. Button front opening.</p> <p>h. Connect electrode harness to proper color-coded signal conditioner. Dot on electrode harness is facing out.</p> <p>i. Perform functional check.</p> <p>j. Adjust ECG gain from normal signal to 40 percent of full scale.</p> <p>k. Adjust ZPN gain to allow maximum inhalation to be at or near full scale.</p>	<p>Use caution in mating biomedical connector to signal conditioners. Connectors are keyed for proper fit.</p> <p>When transferring bioinstrumentation between CWG and LCG, or when reinstalling after removal, the signal conditioners should not be removed from the pockets in the biomedical belt. Only the nine-pin Airlock connector, sternal electrode harness (blue code), and the auxiliary harness (yellow code) should be disconnected. The color code of the harness-to-signal conditioner should be observed when reinstalling the biomedical belt. The electrodes are <u>not</u> removed from skin to change garments.</p>	

STEP	PROCEDURE	REMARKS
4.1.1.3 Donning UCTA	<ul style="list-style-type: none"> a. Obtain proper size cuff and roll down to cuff flange after removing flange from UCTA. b. Place penis in flange and roll cuff on. c. Attach cuff half of the UCTA flange to the UCTA by depressing the flange release lever and twisting the two halves together. d. Aline the colored waistband patches with the corresponding colors on the UCTA. e. Attach the crotch strap to the UCTA. f. Connect hand pump to drain hose and evacuate all gas from the UCTA through the drain hose. 	<p>Place waistband of harness across small of back.</p> <p>Strap length can be adjusted at mating point. Verify that all straps are attached.</p> <p>This step is required for donning at 14.7-psia ambient pressure only; not required for 5-psia donning.</p>
4.1.1.4 Donning TLSA	<p>4.1.1.4.1 <u>Donning EV A7LB TLSA.-</u></p> <ul style="list-style-type: none"> a. Remove protective covers, gas connector caps, etc., from TLSA as required, and stow. b. Open ITMG slide fastener (zipper) cover flap. 	<p>See paragraph 4.1.1.4.2 for CMP A7LB TLSA donning instructions.</p>

4.1 PGA DONNING AND DOFFING

STEP	PROCEDURE	REMARKS
j.	Remove water connector plug.	Disregard this step if LCG is not worn.
k.	Engage the LCG water connector to the TLSA multiple water connect receptacle, if LCG is worn.	If water connector proves difficult to engage, check to make sure the locking balls are retracted and the locking ring on the receptacle is in the open position. Verify that the LCG connector is fully engaged and the receptacle fully connected.
l.	Make certain that PGA locking ring receptacle is in the CLOSE position.	
m.	Insert hands into shoulder convolutes, and lower and position head into neck ring while simultaneously slipping hands fully into arms and through wrist disconnects.	This and the following steps have proven satisfactory for the majority of test subjects. Alternate methods, such as full insertion of head through neck ring, or insertion of one arm and then the combined insertion of second arm and head, are acceptable provided the load on the TLSA, and/or the slide fastener assemblies is not increased.
n.	Assume a semierect position and slide the upper torso down over the shoulder and back.	
o.	Gradually assume an erect standing position, and, at the same time, work the lower half of the suit up over the buttocks. Keep pushing the CWG or LCG and UCTA down inside the TLSA.	

STEP	PROCEDURE	REMARKS
<p>p. After the bottom half of the TLSA is donned over the buttocks, reach back and remove the donning assist-hook lanyard from the Velcro attachment point. Pull the upper half of the TLSA around the body to the left in a counterclockwise position, and engage the assist hook over the front end of the right LM tether bracket. This will enable the subject to move his body within the suit and position the suit relative to his body.</p> <p>q. Adjust the TLSA over the body and tuck in the excess material of the CWG or LCG and UCTA. Then, reach around the body and pull the lower half of the pressure-sealing closure up and the top half of the pressure-sealing closure down.</p> <p>r. Close the pressure-sealing zipper by moving the pressure-sealing slider down and around the back while leaning in the direction of the slider direction. Pull the slider around the left side of the TLSA and up against the pressure-sealing closure lock, and engage and secure zipper lock.</p> <p style="text-align: center;"><u>WARNING</u></p> <p>Check to ensure zipper lock is fully engaged by pulling out on its lanyard and attempting to disengage the assembly.</p>	<p>Make sure that the CWG or LCG and UCTA are tucked in and out of the way of the slider. While closing the pressure-sealing zippers, grasp ahead of the red lanyard on the pressure-sealing slider and pull the slider down until the lanyard can be reached (approximately 10 inches). Gradually move the slider around the closure keeping the hand as close to the slider as possible. Never force the slider. If it seems to stick, back the slider off slightly, check to see if there is any CWG, LCG, or UCTA material in the way, and then pull again. The slider will stick if the lips of the closure are folded in. Backing off the slider slightly and leaning in the direction of the slider will generally clear this condition and the slider will close more easily.</p>	

BASIC DATE

May 1969

CHANGE DATE

June 1971

PAGE 4-8

STEP	PROCEDURE	REMARKS
s. Close vertical restraint zipper by grasping the neck ring and exerting an upward force while simultaneously pulling downward on the blue lanyard until the slider reaches its stop at the right waist. t. Disconnect the donning lanyard (yellow) hook from the LM tether hook and reconnect it to its Velcro attachment point. u. Grasp the blue lanyard on the waist restraint zipper and pull the slider horizontally around to its stop at the right waist. Relieve the load on the slider to ease fastening by constantly leaning in a direction that would be slightly ahead of the slider as it travels.	<p>The slider lock will not operate until the slider is fully seated against the stop.</p> <p>When the zipper is fully closed, the slide yoke is hinged over the lock and the zipper latch is moved into its lock position by the cloth lanyards.</p> <p>Engage donning-aid hooks to assist in the alignment of the vertical restraint zipper. While closing the restraint zippers, constantly tuck in the bladder material with two or three fingers ahead of the slider as it is moved to prevent binding.</p>	

APOLLO OPERATIONS HANDBOOK - EMU

CSD-A-789-(2) III

4.1 PGA DONNING AND DOFFING

STEP	PROCEDURE	REMARKS
v.	<p>Engage and seat restraint zipper slider into the slot in the restraint zipper lock and secure lock.</p> <p style="text-align: center;"><u>WARNING</u></p> <p>Verify that restraint zipper lock assembly is fully engaged and locked.</p> <p>w. Close ITMG entrance closure over zipper and engage hook-and-pile fastener tape strips.</p> <p style="text-align: center;"><u>CAUTION</u></p> <p>To engage the electrical connectors, aline the connector halves and gently slide the halves together until the locks engage. Under no circumstances shall electrical connectors be forcibly engaged.</p> <p>x. Don communications carrier, and unsnap electrical lead retainer from liner and connect electrical lead to upper branch of electrical harness. Then tuck connector and lead to comfortable position within TLISA, and connect electrical umbilical to TLISA and test system.</p>	<p>Lock the slider in place by placing the thumb upon the top of the lock assembly and the index finger over the red striker and squeezing until the lock-lock tab snaps into the lock position.</p> <p>Do not bend mike boom more than 80° from center. Bend mike boom from the middle section only. Do not straighten or bend the mike boom unless necessary.</p>

STEP	PROCEDURE	REMARKS
	<p style="text-align: center;"><u>CAUTION</u></p> <p>Gas umbilicals must be inserted straight into the gas connectors to prevent excessive side loading and subsequent damage to gas connector O-ring seals. To prevent an inadvertent overpressure, always connect the outlet umbilical first.</p> <p>y. Connect outlet gas umbilical to exhaust gas connector.</p> <p>z. Connect gas inlet umbilical to inlet gas connector.</p> <p>aa. Provide ventilation flow.</p> <p>4.1.1.4.2 <u>Donning CMP A7LB TLSA.-</u></p> <p>a. Remove protective cover from TLSA electrical connector and two protective plugs from gas connectors and stow.</p> <p>b. Loosen torso tiedown strap.</p> <p>c. Fully open both the restraint and pressure-sealing zippers.</p> <p>d. Grasp TLSA at sides. Do <u>not</u> pick up TLSA at pressure-sealing zipper location. Place both feet into PGA and work feet into the boots.</p>	<p>Remove donning lanyards from UCTA/ biomedical injection access flap.</p> <p>If unassisted, insert the red suit-donning lanyard through the pull tab of restraint zipper slider and the blue suit-donning lanyard through the pull tab of pressure-sealing zipper slider.</p>

4.1 PGA DONNING AND DOFFING

STEP	PROCEDURE	REMARKS
e.	<p>Pull excess liner material up around leg. Grab PGA at knee convolutes and pull boots onto feet.</p> <p style="text-align: center;"><u>CAUTION</u></p> <p style="text-align: center;">Do not sit on zippers.</p>	<p>Point toes toward boots to avoid pickup of excess liner material.</p>
f.	<p>Pull TLSA to knee position.</p>	
g.	<p>With front of TLSA hanging forward, go to squatting position placing TLSA front in lap.</p>	
h.	<p>Reach inside of right leg and connect UCTA quick disconnect to TLSA-UCTA hose assembly.</p>	
i.	<p>Aline index marks and connect biomedical harness electrical branch to suit electrical harness.</p>	
j.	<p>Verify that the communications carrier connection from electrical harness is pushed through neck ring.</p>	
k.	<p>Insert one arm completely into TLSA arm while simultaneously inserting head into neck ring with assistance from free arm. Insert free arm into other PGA arm.</p>	<p>Alternate methods, such as full insertion of arms into suit sleeves and then the insertion of head through neck ring, or insertion of one arm and then the combined insertion of second arm and head, are acceptable provided the load on the TLSA and/or the zippers is not increased.</p>
l.	<p>Stand erect to permit TLSA to settle over torso and limbs.</p>	

STEP	PROCEDURE	REMARKS
m.	<p>Close restraint and pressure-sealing zipper closures.</p>	<p>If unassisted, grasp back of neck ring and top of CWG with one hand. With other hand, grasp red donning lanyard, pull out and down to position restraint zipper slider toward middle of the back. Pull red donning lanyard over buttocks while running fingers ahead of slider to prevent snagging of CWG.</p> <p>Grasp cloth tab of restraint slider and close fully.</p> <p>Remove suit-donning lanyard, tuck slider tab up into TLSA, and stow lanyard in pocket.</p> <p>Grasp back of neck ring with one hand and, with other hand, grasp blue donning lanyard. Pull lanyard out and down to fully close pressure-sealing zipper.</p> <p>Remove and stow blue suit-donning lanyard.</p>
n.	<p>Engage snap fastener of slider tab to receptacle on TLSA.</p> <p>Position lock assembly over slider and push lock button to LOCK.</p> <p>Close cover flap over zipper and engage snap fasteners.</p>	
o.	<p>Don communications carrier by spreading the ear cups, and then make fine adjustments to the mike boom by bending it from the center.</p> <p>Adjust the chinstrap for proper fit.</p>	<p>Do not bend mike boom more than 80° from center. Bend mike boom from the middle section only. Do not straighten or bend the mike boom unless necessary.</p>

STEP	PROCEDURE	REMARKS
p.	Connect electrical lead to upper branch of electrical harness. <p style="text-align: center;"><u>CAUTION</u></p> Gas umbilicals must be inserted straight into the gas connectors to prevent excessive side loading and subsequent damage to gas connector O-ring seals.	
q.	Connect gas outlet umbilical to exhaust gas connector. <p style="text-align: center;"><u>CAUTION</u></p> To prevent an inadvertent overpressure, always connect the outlet umbilical first.	
r.	Connect gas inlet umbilical to inlet gas connector.	
s.	Provide ventilation flow.	
4.1.1.5	Donning Pressure Helmet	Paragraphs 4.1.1.5 and 4.1.1.6 can be reversed provided that paragraph 4.1.1.5 is accomplished with decreased gas flow.
a.	Place helmet-attaching ring lock subassembly in ENGAGE. <p style="text-align: center;"><u>CAUTION</u></p> PGA neck ring alignment marks must be aligned with the helmet-engaged alignment marks to ensure proper helmet ventilation.	

STEP	PROCEDURE	REMARKS
b.	Place pressure helmet on helmet-attaching ring, ensure proper alinement by alining dual white lines, and press down on helmet.	
c.	Position lock subassembly to LOCK.	
4.1.1.6	Donning IV Gloves	
a.	Gloves or helmet may be difficult to don. If so, stop gas flow momentarily.	
b.	Place suit wrist disconnects in ENGAGE.	
c.	Ensure that glove palm restraint is loosened, then place hand into glove.	
d.	Aline glove wrist disconnect with suit wrist disconnect and engage both units.	
e.	Ensure that glove can be easily rotated and place the wrist disconnect to LOCK.	
f.	Adjust glove palm restraint.	
g.	Don other glove in the same way.	

BASIC DATE

May 1969

CHANGE DATE

June 1971

PAGE

4-14

STEP	PROCEDURE	REMARKS
4.1.2 <u>PGA Doffing Procedures After IV Use</u> 4.1.2.1 Doffing IV Gloves a. Decrease suit pressure to less than 0.75 psig. b. Loosen palm restraint if required. c. Place wrist disconnect in OPEN position and remove glove. d. Doff other glove. 4.1.2.2 Doffing Pressure Helmet a. Depress tab, pull helmet-attaching ring latching mechanism, and rotate to the OPEN position. b. Lift the helmet up and out of helmet-attaching ring. 4.1.2.3 Doffing TLSA 4.1.2.3.1 <u>Doffing EV A7LB TLSA.-</u> a. Empty UCTA. b. Open slide fastener cover flap on ITMG. c. Release the restraint zippers by pushing the lock on the restraint zipper lock assembly to the left and the red striker of the slider lock downward.		See AOH LM and CSM procedures. See paragraph 4.1.2.3.2 for CMP A7LB doffing instructions.

BASIC DATE May 1969

CHANGE DATE June 1971

PAGE 4-15

STEP	PROCEDURE	REMARKS
d.	Grasp blue restraint zipper lanyard and pull upward until the zipper is fully open (pull lanyard under shoulder restraint cable as required). Grasp the blue waist zipper lanyard and pull around rear of suit to stop at left waist.	Disengage the donning aid hooks used to aline the vertical restraint zippers.
e.	With the right thumb, press downward on the arm assembly of the pressure-sealing zipper lock directly over the shaft and turn the arm clockwise with the index finger until the detent is engaged at the full-open position.	
f.	Grasp red pressure-sealing zipper lanyard and pull slider around rear waist to right side and fully upward to end of zipper at right shoulder (pull lanyard under shoulder restraint cable as required).	
g.	Disconnect gas inlet and outlet umbilicals.	
h.	Disconnect communications carrier electrical connector.	
i.	Grasp the TLSA at waist-entry area and separate the slide fasteners. Assume semierect position and slip the TLSA from around the buttocks and downward over legs.	
j.	If used, disconnect LCG multiple water connector, insert water connector plug into multiple water connector receptacle from the inside outward, and lock in place.	
k.	Grasp the helmet-attaching ring, slide head out, and pull both arms away from TLSA.	An alternate method of removing the TLSA by first removing one arm and then removing the head and other arm simultaneously is acceptable provided the load on the TLSA and/or zippers is not increased.

4.1 PGA DONNING AND DOFFING

STEP	PROCEDURE	REMARKS
<p>1. Roll back cover to expose urine connector. Disconnect urine connector and biomedical connector.</p> <p>m. Work the TLSA downward and remove legs from TLSA.</p> <p>4.1.2.3.2 <u>Doffing CMP A7LB TLSA.-</u></p> <p>a. Empty UCTA.</p> <p>b. Open zipper-cover flap. Unlock pressure-sealing zipper lock and release slider tab snap fastener.</p> <p>c. Fully open pressure and restraint zippers.</p> <p style="text-align: center;"><u>CAUTION</u></p> <p style="text-align: center;">Do not sit on zippers.</p>		<p>Don LCG booties after removing feet from TLSA. Remove LCG interconnect adapter and CWG electrical harness from stowage area. Close the restraint zipper before stowage.</p> <p>See AOH LM and CSM procedures.</p> <p>If unassisted, remove blue donning lanyard from lanyard pocket and insert into pressure-sealing zipper tab. Grasp blue suit-donning lanyard, pull until the pressure-sealing zipper tab is fully OPEN, and remove suit-donning lanyard.</p> <p>Remove red suit-donning lanyard from lanyard pocket, release restraint zipper tab from stowed position, and insert lanyard in zipper tab.</p> <p>Grasp red suit-donning lanyard, pull until restraint zipper is full OPEN, and remove lanyard. Restow red and blue lanyards.</p>

BASIC DATE

May 1969

CHANGE DATE

June 1971

PAGE 4-18

CSD-A-789-(2) III
APOLLO OPERATIONS HANDBOOK - EMU

STEP	PROCEDURE	REMARKS
d.	Disconnect gas inlet and outlet hoses.	
e.	Disconnect communications carrier electrical lead and undo chinstrap to remove communications carrier. Remove communications carrier carefully. Do <u>not</u> bend mike boom.	
f.	Grasp PGA at rear entry area and separate slide fasteners; then slip TLSA from around back and buttocks.	
g.	Grasp helmet-attaching ring, slip head out, and pull both arms away from TLSA.	
h.	Disconnect biomedical connector.	
i.	Disconnect UCTA drain hose quick disconnect.	See paragraph 4.1.2.
j.	Remove legs from TLSA.	
k.	Replace protective covers and caps on TLSA electrical connector and two gas connectors.	
4.1.2.4	Doffing UCTA	
a.	Drain UCTA before doffing.	See AOH LM and CSM procedures.
b.	Partially doff PGA to disconnect the UCTA drain hose disconnect.	
c.	Disconnect UCTA drain hose from suit-mounted UCTA transfer hose assembly.	
d.	Complete doffing of PGA.	

4.1 PGA DONNING AND DOFFING

STEP	PROCEDURE	REMARKS
e. f. g. h.	Remove UCTA elastic harness by detaching waistband Velcro patches while holding UCTA in place. Remove cuff half of UCTA flange by using release button and twisting motion. Roll cuff from penis. Fold cuff and use UCTA clamp to close.	
4.1.2.5 a. b.	Doffing Bioinstrumentation and CWG Disconnect electrical leads of biomedical electrode harness from signal conditioners in biomedical belt. Disengage snaps securing biomedical belt.	To permanently remove bioinstrumentation system, remove bioinstrumentation system and cover exposed end of the PGA electrical umbilical and/or T-adapter cable with tape P/N SEB12100050-201 (on board). Use caution in mating or unmating biomedical connector to or from signal conditioners. Connectors are keyed for proper fit. When transferring bioinstrumentation between CWG or LCG, or when reinstalling after removal, the signal conditioners should not be removed from the pockets in the biomedical belt. Only the nine-pin Airlock connector, the sternal electrode harness (blue code), and the auxiliary harness (yellow code) should be disconnected. The color

STEP	PROCEDURE	REMARKS
	<p>c. Unbutton front opening.</p> <p>d. Pass bioinstrumentation electrode harness leads through a hole on chest area of CWG.</p> <p>e. Remove CWG in the same manner as conventional long underwear.</p>	<p>code of the harness-to-signal conditioner should be observed when reinstalling the biomedical belt. The electrodes are <u>not</u> removed from skin to change garments.</p>
4.1.2.6	Doffing FCS	
	<p>a. Doff FCS in the same manner as conventional underwear shorts.</p>	
4.1.3	<u>PGA Donning Procedures Before EV Use</u>	
4.1.3.1	Donning FCS	
	See paragraph 4.1.1.1.	
	<p style="text-align: center;"><u>NOTE</u></p> <p>Don UCTA first (para 4.1.1.3) when LCG is to be worn.</p>	
4.1.3.2	Donning Bioinstrumentation and LCG or CWG	<p>The LCG replaces the CWG for EVA. The LCG may be worn during periods of IVA. Verify that the UCTA hose is pulled completely through the LCG after donning LCG.</p>

4.1 PGA DONNING AND DOFFING

STEP	PROCEDURE	REMARKS
4.1.3.2.1	<p><u>Donning Bioinstrumentation and LCG.-</u></p> <p style="text-align: center;"><u>CAUTION</u></p> <p style="text-align: center;">Exercise care to avoid damaging LCG waterlines.</p> <p>a. Unstow LCG from bag.</p> <p>b. Open front entry fastener of LCG.</p> <p>c. Don the LCG to waist as conventional long underwear.</p> <p>d. Adjust feet into integrated socks.</p> <p>e. Clean shaved electrode sites with alcohol and let dry.</p> <p>f. Assemble signal conditioners, biomedical harness with biomedical belt, and test as a system.</p> <p>g. Insert bioinstrumentation leads through slots on chest area of LCG. Don top half of LCG, insert harness connector (blue and yellow) through holes in LCG. Snap biomedical belt to LCG.</p>	<p>The steps that prescribe the installation of the bioinstrumentation may be skipped when its use is not required (steps e through g, and j through m).</p> <p>The LCG will not interface with the CMP A7LB TISA.</p> <p>See AOH LM procedures.</p> <p>Use caution in mating biomedical connector to signal conditioners. Connectors are keyed for proper fit.</p> <p>When transferring bioinstrumentation between LCG or CWG or when reinstalling after removal, the signal conditioners should not be removed from the pockets in the biomedical belt. Only the nine-pin Airlock connector,</p>

BASIC DATE

May 1969

CHANGE DATE

June 1971

PAGE 4-22

STEP	PROCEDURE	REMARKS
	<p>h. Complete LCG donning.</p> <p>i. Close front entry.</p> <p>j. Connect electrode harness to proper color-coded signal conditioner. Dot on electrode harness is facing out.</p> <p>k. Perform functional check.</p> <p>l. Adjust ECG gain from normal signal to 40 percent of full scale.</p> <p>m. Adjust ZPN gain to allow maximum inhalation to be at or near full scale.</p> <p>4.1.3.3 Donning TLSA</p> <p>4.1.3.3.1 <u>Donning EV A7LB TLSA</u>.- See paragraph 4.1.1.4.1.</p> <p>4.1.3.3.2 <u>Donning CMP A7LB TLSA</u>.- See paragraph 4.1.1.4.2.</p>	<p>the sternal electrode harness (blue code), and the auxiliary harness (yellow code) should be disconnected. The color code of the harness-to-signal conditioner should be observed when reinstalling the biomedical belt. The electrodes are <u>not</u> removed from skin to change garments.</p> <p>Verify that LCG manifold is outside of biomedical belt.</p>

APOLLO OPERATIONS HANDBOOK - EMU

CSD-A-789-(2) III

4.1 PGA DONNING AND DOFFING

STEP	PROCEDURE	REMARKS
4.1.3.4	Donning Lunar Boots a. Insert PGA boots into lunar boots and position with attached donning straps. b. Engage snap fasteners on tongue of boot. c. Latch adjustment strap and buckle.	
4.1.3.5	Donning PLSS/OPS See paragraph 4.3.1.	
4.1.3.6	Donning Pressure Helmet a. Apply antifog solution. b. Helmet may be difficult to don. If so, stop gas flow momentarily. <p style="text-align: center;"><u>CAUTION</u></p> <p style="text-align: center;">Prior to donning helmet, PGA diverter valves must be EV (vertical) position if O₂ flow is to be provided by PLSS/OPS.</p> c. Place helmet-attaching ring lock subassembly in ENGAGE. d. Place pressure helmet on helmet-attaching ring, ensure proper alinement by alining dual white lines, and press down on helmet.	See paragraph 4.10.1.2.a.

STEP	PROCEDURE	REMARKS
	<p>e. Position lock subassembly to LOCK.</p> <p style="text-align: center;"><u>CAUTION</u></p> <p>PGA neck ring alinement marks must be alined with the helmet-locked alinement marks to ensure proper helmet ventilation.</p> <p>4.1.3.7 Donning EV Gloves</p> <p>a. Don comfort gloves and wristlets if desired.</p> <p>b. Roll glove gauntlet back to provide access to wrist disconnect.</p> <p>c. Place suit wrist disconnect in ENGAGE.</p> <p>d. Gloves may be difficult to don. If so, stop gas flow momentarily.</p> <p>e. Loosen palm restraint if necessary and place hand into glove.</p> <p>f. Aline glove wrist disconnect with suit wrist disconnect and engage both units.</p> <p>g. Ensure gloves rotate easily and place suit wrist disconnects in their LOCK position.</p> <p>h. Roll glove gauntlet back over wrist ring.</p> <p>i. Adjust palm restraint as desired. Close cover flap and engage fasteners.</p>	

4.1 PGA DONNING AND DOFFING

BASIC DATE May 1969 CHANGE DATE June 1971 PAGE 4-24

STEP	PROCEDURE	REMARKS
<p>4.1.3.8 Donning LEVA</p> <p>a. Verify that visors are open (up).</p> <p>b. Disengage latching mechanism through access on LEVA collar.</p> <p>c. Place LEVA over pressure helmet and lower onto helmet-attaching ring.</p> <p>d. Aline separation of plastic collar with helmet-engaged alinement marks.</p> <p>e. Ensure LEVA is properly located on attaching ring and lock.</p> <p>f. Lower collar to cover neckring and fasten front and back.</p> <p style="text-align: center;"><u>CAUTION</u></p> <p style="text-align: center;">Collar must conceal helmet-attaching ring area for lunar surface activity only.</p>	<p>LEVA may be installed on helmet before donning helmet, thereby allowing LEVA and helmet to be donned as a unit.</p> <p>Raise LEVA collar prior to helmet donning, then don helmet with LEVA and lower collar to cover neckring and fasten front and back.</p> <p>Aline LEVA by using the projecting PGA feed-port as a guide.</p>	
<p>4.1.3.9 Donning BSLSS</p> <p>See paragraph 4.11.3.</p>		
<p>4.1.4 <u>PGA Doffing Procedures After EV Use</u></p>	<p>The EMU is assumed to be in the same configuration as at end of extravehicular configuration donning procedures.</p>	

STEP	PROCEDURE	REMARKS
4.1.4.1	Disconnecting BSLSS See paragraph 4.11.7	
4.1.4.2	Doffing EV Gloves a. Decrease PGA pressure flow to 0.75 psig or less. b. Roll glove gauntlet back and put wrist disconnect in OPEN position. c. Doff glove. d. Similarly doff other glove.	
4.1.4.3	Doffing LEVA a. Verify both visors in full OPEN (up) position. b. Disengage fastener tapes of LEVA collar. c. Disengage locking mechanism. d. Ease LEVA up and off pressure helmet.	LEVA may be doffed with helmet as a unit. Raise LEVA collar and remove helmet per paragraph 4.1.4.4.
4.1.4.4	Doffing Helmet a. Depress tab, pull helmet-attaching ring latching mechanism and rotate to the OPEN position. b. Ease pressure helmet up and out of helmet-attaching ring.	

BASIC DATE

May 1969

CHANGE DATE

June 1971

PAGE

4-26

4.1 PGA DONNING AND DOFFING

STEP	PROCEDURE	REMARKS
4.1.4.5	Doffing PLSS/OPS See paragraphs 4.3.2 and 4.3.3	
4.1.4.6	Doffing Lunar Boots a. Unbuckle adjusting strap and unsnap fasteners. b. Slip boots off.	
4.1.4.7	Doffing TLSA See paragraph 4.1.2.3.	
4.1.4.7.1	<u>Doffing EV A7LB TLSA.</u> - (See paragraph 4.1.2.3.1.)	
4.1.4.7.2	<u>Doffing CMP A7LB TLSA.</u> - (See paragraph 4.1.2.3.2.)	
4.1.4.8	Doffing UCTA See paragraph 4.1.2.4.	
4.1.4.9	Doffing Bioinstrumentation and CWG or LCG	
4.1.4.9.1	<u>Doffing LCG.</u> - a. Disconnect electrical leads of biomedical electrode harness from signal conditioners in biomedical belt. b. Disengage snaps securing biomedical belt.	To permanently remove bioinstrumentation system, remove bioinstrumentation system and cover exposed end of the PGA electrical umbilical and/or T-adapter cable with tape P/N SEB12100050-201 (on board). Use caution in mating or unmating biomedical connector to or from signal conditioners. Connectors are keyed for proper fit.

BASIC DATE

May 1969

CHANGE DATE

June 1971

PAGE 4-28

STEP	PROCEDURE	REMARKS
	c. Open front entry. d. Pass bioinstrumentation electrode harness leads through holes in chest area of LCG. e. Remove LCG in the same manner as conventional long underwear. 4.1.4.9.2 <u>Doffing CWG.</u> - (See paragraph 4.1.2.5.) 4.1.4.10 Doffing FCS See paragraph 4.1.2.6.	When transferring bioinstrumentation between CWG or LCG, or when reinstalling after removal, the signal conditioners should not be removed from the pockets in the biomedical belt. Only the nine-pin Airlock connector, the sternal electrode harness (blue code), and the auxiliary harness (yellow code) should be disconnected. The color code of the harness-to-signal conditioner should be observed when reinstalling the biomedical belt. The electrodes are <u>not</u> removed from skin to change garments.

4.1 PGA DONNING AND DOFFING

APOLLO OPERATIONS HANDBOOK - EMU

CSD-A-789-(2) III

STEP	PROCEDURE	REMARKS
4.2	OPS OPERATIONS	
4.2.1	<u>OPS Checkout</u>	
	a. Open access flaps and verify OPS bottle pressure gage reads 5880 ± 500 psia.	
	b. Verify OPS O ₂ connector locked in stowage plate.	
	c. Set OPS actuation lever to ON.	
	d. Verify OPS regulator checkout gage reads 3.70 ± 0.30 psid.	
	e. Set OPS O ₂ actuation lever to OFF.	The OPS regulator checkout gage will continue to read 3.7 ± 0.3 psid for approximately 3 minutes after OPS actuation lever is OFF.
	f. Secure all access flaps.	
	g. Verify OPS regulator checkout gage less than 2.5 psi.	
4.2.2	<u>OPS Donning Prior to Contingency Transfer</u>	
	a. Pull out tear-tack stitches on the PLSS adjustable harness by yanking on end tab until strap is free.	
	b. Open thermal cover over strap buckle adjustment and remove retaining spring clip.	

STEP	PROCEDURE	REMARKS
	<p>c. Join the fixed waist harness to the adjustable waist harness of the PLSS using the D-buckle under the thermal cover of the adjustable harness (PLSS attachment end) and the hook under the thermal cover on the fixed length strap (PLSS attachment end). The hook on the free end of the straps should be faced inward.</p> <p>d. Loop harnesses around the back of PGA and thread through LM tether restraints.</p> <p>e. Remove OPS O₂ connector from stowage plate.</p> <p>f. Hook harnesses to OPS.</p> <p>g. Install OPS oxygen connector (blue) into one of the PGA inlet oxygen connectors (blue) and verify locked.</p> <p>h. Install purge valve into one of the PGA outlet oxygen connectors (red) and verify locked.</p> <p>i. Open OPS actuator access flap.</p> <p>j. Adjust harnesses to secure OPS. Allow for the expansion of the PGA when pressurized.</p> <p>4.2.3 <u>OPS Donning Before CMP EVA</u></p> <p>a. Perform OPS checkout per paragraph 4.2.1.</p> <p>b. Verify OPS pressure indicated on checkout gage is less than 2.5 psid.</p>	

BASIC DATE May 1969

CHANGE DATE June 1971 PAGE 4-30

STEP	PROCEDURE	REMARKS
	<p>c. Unstow OPS O₂ connector.</p> <p>d. Attach straps (4) to the OPS.</p> <p>e. Attach OPS adapter plate to PGA upper PLSS bracket.</p> <p>f. Don OPS by attaching the OPS bottom straps (2) to the PGA D-ring and the OPS top straps (2) to the adapter plate.</p> <p>g. Route OPS actuator cable over right shoulder and back to adapter plate.</p> <p>h. Route OPS O₂ hose under OPS and under left arm. Connect to the left PGA inlet O₂ connector (blue).</p> <p>i. Verify hose connector is locked.</p>	<p>Left OPS strap attaches to the left side of the adapter plate and right OPS strap attaches to the right side of the adapter plate.</p>

BASIC DATE May 1969

CHANGE DATE June 1971 PAGE 4-31

BASIC DATE

May 1969

CHANGE DATE

June 1971

PAGE

4-32

STEP	PROCEDURE	REMARKS
4.2.4	<u>OPS Activation</u> Move OPS actuation lever from OFF to ON position (pull down, rotate up) and allow it to lock.	
4.2.5	<u>OPS Deactivation</u> Move OPS actuation lever from ON to OFF position (pull up, rotate down) and allow it to lock.	
4.2.6	<u>OPS Doffing After CMP EVA</u> a. Disconnect OPS actuator from adapter plate. b. Disconnect OPS O ₂ hose connector from PGA. c. Disconnect straps (4) from adapter plate and PGA D-ring. d. Remove OPS adapter plate and stow.	

4.2 OPS OPERATIONS

APOLLO OPERATIONS HANDBOOK - EMU

CSD-A-789-(2) III

STEP	PROCEDURE	REMARKS
4.3	PLSS/OPS DONNING AND DOFFING	
4.3.1	<u>PLSS/OPS Donning</u>	
a.	Open access flap, unstow antenna connector, OPS half, and secure access flaps.	
b.	Lift OPS locking pin.	Helmet and gloves off. PGA donned. PGA diverter valves (2) horizontal.
c.	Slide OPS onto PLSS from left to right while facing PLSS conformal side.	
d.	Push locking pin down.	
e.	Remove EVCS antenna connector (J5) dust cap.	
f.	Connect antenna connector OPS half to antenna connector PLSS half. Screw on CW.	
g.	Verify sublimator exhaust is clear.	
h.	Unstow PLSS shoulder and waist harnesses.	
i.	Unstow PLSS PGA electrical umbilical, inlet and outlet O ₂ , and multiple water connectors.	Conformal side of PLSS is the side that conforms to the crewman's back when PLSS is donned.
j.	Remove battery cable from stowage plate. Rotate battery cable handle CCW (90° to alignment marks).	
k.	Remove battery connector (J6) dust cap and stow on battery cable stowage plate.	Visual inspection.

BASIC DATE

May 1969

CHANGE DATE

June 1971

PAGE

4-34

CSD-A-789-(2) III
APOLLO OPERATIONS HANDBOOK - EMU

STEP	PROCEDURE	REMARKS
1. Connect battery cable to battery. 1. Aline marks on battery cable body and handle. 2. Aline marks on battery cable handle and battery. 3. Connect battery cable to battery connector and rotate handle CW (90°). m. Remove dust cap RCU connector (J3), PLSS half. Twist CCW. n. Verify OPS actuation lever is OFF and OPS regulator check-out gage reads less than 2.5 psi. o. Unstow OPS connector. Pull stowage plate tabs and rotate CCW. p. Secure PLSS/OPS access flaps. q. Don PLSS/OPS by securing shoulder and waist harnesses to the PGA upper and lower PLSS brackets. r. Connect PLSS O ₂ outlet (blue) to inboard PGA inlet connector (blue) and PLSS O ₂ inlet (red) to upper PGA outlet connector (red). Connect PLSS multiple water connector to PGA multiple water connector (blue). Connect PLSS/PGA electrical umbilical and lock. s. Before connecting RCU, verify: PLSS pump switch — OFF, PLSS fan switch — OFF, and PLSS mode selector switch — position 0 (OFF).		Do not unstow OPS oxygen hose at this time.

4.3 PLSS/OPS DONNING AND DOFFING

STEP	PROCEDURE	REMARKS
t.	Connect RCU electrical connector to the PLSS. <ol style="list-style-type: none"> 1. Aline marks on RCU connector body and handle. 2. Aline marks on RCU connector and PLSS, insert, and rotate CW 90°. 	
u.	Attach RCU to PLSS straps and PGA as follows: <ol style="list-style-type: none"> 1. Pull Velcro strap away from front of RCU. 2. Using strap as a grip, pull directly forward of RCU and then down. Release strap to lock in open position. 3. Insert lower clip to PGA upper PLSS bracket. 4. Raise RCU and insert the left shoulder clip into left RCU clip, then clip the right side. 5. To lock clips, pull strap handle forward and up to a horizontal position and release. Verify hooks are locked in closed position. 6. Restow Velcro strap handle on front of RCU. 	
v.	Unstow OPS hose.	
w.	Depress OPS actuation lever bracket tab and unstow actuation lever cable.	

BASIC DATE May 1969
 CHANGE DATE June 1971
 PAGE 4-35

STEP	PROCEDURE	REMARKS
x. 1. 2. y. z. aa. ab.	Attach OPS actuation lever to the RCU. Insert lower pins on the OPS actuation lever into the RCU actuation lever bracket slots. Push upper portion of the OPS actuation lever toward the bracket until the upper pins engage the bracket and snap is locked. Install OPS connector to the unused PGA connector (blue to blue) and lock. Install purge valve in unused PGA O ₂ connector (red to red). Secure all PLSS/OPS access flaps and verify gas connector lock locks (4). Unstow antenna.	
4.3.2	<u>PLSS/OPS Doffing in Pressurized Environment</u>	a. Helmet and gloves off. b. PLSS primary and auxiliary feedwater valves closed (up). c. PLSS O ₂ shutoff valve off (up). d. LM is at 5 psia. e. OPS actuation lever off.

4.3 PLSS/OPS DONNING AND DOFFING

STEP	PROCEDURE	REMARKS
	<p>a. Remove OPS actuation lever from RCU.</p> <p>b. Disconnect RCU from PGA upper PLSS bracket and PLSS shoulder harnesses.</p> <ol style="list-style-type: none"> 1. Pull Velcro strap away from front of RCU. 2. Using strap as a grip, pull directly forward of RCU and then down. Release strap to lock in open position. 3. Lift RCU from left shoulder strap, then right. 4. Lower RCU from PGA upper PLSS bracket. <p style="text-align: center;"><u>CAUTION</u></p> <p>Before disconnecting RCU, all electrical PLSS controls must be OFF.</p> <p>PLSS pump switch — OFF</p> <p>PLSS fan switch — OFF</p> <p>PLSS mode selector switch — Position 0 (OFF)</p> <p>c. Disconnect RCU electrical umbilical from PLSS by rotating RCU connector handle CCW (90°).</p> <p>d. Disconnect inlet and outlet O₂ and multiple water connectors, electrical umbilical connector, and OPS O₂ connector. The electrical umbilical connector is pulled away from the PGA and rotated CCW to remove.</p>	

STEP	PROCEDURE	REMARKS
e.	Remove the purge valve and stow.	
f.	Remove PLSS shoulder and waist harnesses from the PGA and doff the PLSS.	
g.	Temporarily stow the PLSS.	
h.	Stow OPS antenna.	
i.	Stow OPS actuation lever.	
1.	Insert lower pins on the OPS actuation lever into the OPS actuation lever bracket slots.	
2.	Push upper portion of the OPS actuation lever down until the upper pins engage the bracket and snap lock in place.	
j.	Verify OPS actuation lever is OFF and locked.	
k.	Stow OPS O ₂ hose and connector; secure OPS access covers.	
1.	Route the hose around the back of the OPS over the actuation lever cable.	
2.	Verify the OPS connector stowage plate is in the open position (CCW).	
3.	Insert the OPS connector and lock the OPS stowage plate connector (twist CW).	
4.	Secure access flaps over OPS hose.	

BASIC DATE May 1969 CHANGE DATE June 1971 PAGE 4-38

4.3 PLSS/OPS DONNING AND DOFFING

STEP	PROCEDURE	REMARKS
4.3.3	<p><u>PLSS/OPS Doffing in Unpressurized Environment</u></p> <p>a. Verify OPS actuation lever OFF.</p> <p>b. Disconnect purge valve and stow.</p> <p>c. Disconnect OPS O₂ connector.</p> <p>d. Connect ECS O₂ umbilicals to PGA (red to red, blue to blue); lock and actuate ECS.</p> <p>e. Set PLSS fan switch OFF.</p> <p>f. Set PLSS O₂ shutoff valve OFF (up).</p> <p>g. Verify PGA pressure gage reads 3.6 to 4.3 psi. Turn PGA diverter valves (2) horizontal.</p> <p>h. Set PLSS mode selector switch to position 0 (OFF).</p> <p>i. Disconnect PLSS PGA electrical umbilical. The electrical umbilical connector is pulled away from the PGA and rotated CCW to remove. Connect LM communication umbilical.</p> <p>j. Verify PLSS primary and auxiliary feedwater valves CLOSED (up).</p> <p>k. Verify PLSS pump switch OFF.</p> <p>l. Remove OPS actuation lever from the RCU. Depress release lever to free actuation lever upper pins and remove.</p>	<p>O₂ shutoff handle safety must be depressed as handle is pulled forward.</p>

STEP	PROCEDURE	REMARKS
	<p>m. Disconnect RCU from PGA upper PLSS bracket and PLSS shoulder harnesses.</p> <ol style="list-style-type: none"> 1. Pull Velcro strap away from front of RCU. 2. Using strap as a grip, pull directly forward of RCU and then down. Release strap to lock in open position. 	

BASIC DATE

May 1969

CHANGE DATE

June 1971

PAGE

4-41

BASIC DATE

May 1969

CHANGE DATE June 1971

PAGE 1-12

STEP	PROCEDURE	REMARKS
3.	Lift RCU from left shoulder strap, then right.	
4.	Lower RCU from PGA upper PLSS bracket.	
	<p style="text-align: center;"><u>CAUTION</u></p> <p>Before electrically disconnecting RCU, all PLSS electrical controls must be in OFF position.</p> <p>PLSS pump switch OFF</p> <p>PLSS fan switch OFF</p> <p>PLSS mode selector switch Position 0 (OFF)</p> <p>n. Disconnect RCU electrical connector from the PLSS. Rotate RCU electrical connector handle CCW to disconnect.</p> <p>o. Disconnect PLSS inlet and outlet O₂ and multiple water connectors. Disconnect outlet O₂ connector (red) first.</p> <p>p. Remove waist harnesses from the PGA.</p> <p>1. Grasp outside loop of right-hand strap between adjustment buckle and PGA hook, and tear tack-stitches adjacent to buckle.</p> <p>2. Unsnap harness keeper between adjustment buckle and PLSS hook.</p> <p>3. Grasp exposed end of strap between PLSS hook and adjustment buckle, and tear tack-stitches.</p>	<p>Crewman will require assistance.</p>

4.3 PLSS/OPS DOWNING AND DOFFING

CSD-A-789-(2) III
APOLLO OPERATIONS HANDBOOK - EMU

STEP	PROCEDURE	REMARKS
	<p>4. Unsnap adjustment-buckle thermal insulation to expose buckle.</p> <p>5. Grasp buckle roller release tab and rotate outward to release grip on harness. Lengthen the harness by use of the adjustment buckle.</p> <p>6. Unhook right-hand harness from PGA.</p> <p>7. Unhook left-hand harness from PGA.</p> <p>q. Remove shoulder harnesses from PGA and doff PLSS/OPS.</p> <p>r. Temporarily stow PLSS/OPS.</p> <p>s. Stow antenna.</p> <p>t. Replace RCU connector (J3) dust cap by alining marks, inserting, and twisting CW.</p> <p>u. Stow PLSS inlet and outlet O₂ hoses and connectors, multiple water hoses and connectors, and PLSS-PGA electrical umbilical in the stowage connectors provided. Refer to hose routing decal on conformal side of PLSS. Verify all connectors locked in place. Secure hoses with hose stowage strap.</p> <p>v. Stow PLSS straps.</p> <p>w. Disconnect OPS antenna connector from EVCS. Unscrew CCW.</p> <p>x. Replace antenna connector dust cap by pushing into place.</p> <p>y. Secure all PLSS thermal flaps.</p>	

BASIC DATE May 1969

CHANGE DATE June 1971

PAGE 4-43

BASIC DATE

May 1969

CHANGE DATE

June 1971

PAGE

4-44

STEP	PROCEDURE	REMARKS
z.	Stow OPS actuation lever. 1. Insert lower pins on OPS actuation lever into OPS actuation lever bracket slots. 2. Push upper portion of OPS/actuation lever down until the upper pins engage the bracket and lock in place. 3. Verify actuation lever is off and locked. aa.	Stow OPS hose and connector, and secure OPS thermal flaps. Hose is routed around the back of the OPS, over the actuator cable, and is held in place by the thermal cover. The connector stowage plate must be rotated full CCW to open before the connector is inserted, and then rotated CW to lock the connector in place.

APOLLO OPERATIONS HANDBOOK - EMU

CSD-A-789-(2) III

BASIC DATE

May 1969

CHANGE DATE

June 1971

PAGE 4-45

STEP	PROCEDURE	REMARKS
4.4	<p>PLSS COMMUNICATIONS CHECK</p> <p>a. Set PLSS mode selector switch to position B.</p> <p>b. Verify 1.5 kHz warble tone on for 10 seconds. Low-vent flow warning flag shows P, low PGA pressure warning flag shows 0.</p> <p>c. Read PLSS O₂ gage (percent of full scale).</p> <p>d. Verify voice communications. Adjust volume.</p> <p>e. Set PLSS mode selector switch to position A.</p> <p>f. Verify 1.5 kHz warble tone on for 10 seconds. Low-vent flow warning flag continues to show P. Low PGA pressure warning flag continues to show 0.</p> <p>g. Read PLSS O₂ gage (percent of full scale).</p> <p>h. Verify voice communications and TM, adjust volume.</p> <p>i. PLSS mode selector switch to position AR.</p> <p>j. Verify 1.5 kHz warble tone on for 10 seconds. Low-vent flow warning flag shows P. Low PGA pressure warning flag shows 0.</p>	<p>Crewmen suited with helmets off. Vent flow provided by LM ECS. OPS, RCU, PLSS, and PGA systems are properly connected. PLSS/EVCS modes interface with LM and CM communications subsystems. Spacecraft switch positions for various communications modes (PLSS, SC, MSFN) are found in the AOH for CSM and LM. PLSS switches and valves off.</p> <p>Increase volume by rotating blade CCW.</p> <p>Increase volume by rotating wheel CCW.</p>

4.4 PLSS COMMUNICATIONS CHECK

 APOLLO OPERATIONS HANDBOOK - EMU
 CSD-A-789-(2) III

STEP	PROCEDURE	REMARKS
	<p>k. Read PLSS O₂ gage (percent of full scale).</p> <p>l. Verify voice communication and TM; adjust volume as required.</p>	

BASIC DATE May 1969

CHANGE DATE June 1971

PAGE 4-46

4.4 PLSS COMMUNICATIONS CHECK

STEP	PROCEDURE	REMARKS
4.5	<p>PRESSURE INTEGRITY CHECK</p> <p>a. Set PLSS O₂ shutoff valve to ON (down).</p> <p>b. Verify PLSS 1.5 kHz warble tone on for 10 seconds. High O₂ flow warning flag shows 0. Low PGA pressure warning flag shows 0 and clears when PGA pressure reaches 3.1 to 3.4 psid.</p> <p>c. Verify high O₂ flow warning flag clears as PGA gage reaches 3.85 ± 0.15 psig.</p> <p>d. Set PLSS O₂ shutoff valve to OFF (up).</p> <p>e. Read PGA pressure gage and monitor pressure decay for 1 minute.</p> <p>f. Report pressure decay.</p> <p>g. Set PLSS O₂ shutoff valve to ON (down).</p>	<p>EMU donned. Ambient pressure 5.0 psia. PLSS fan in ON. PLSS primary and auxiliary valves CLOSED.</p> <p>O₂ shutoff handle safety must be depressed as handle is pulled forward.</p> <p>This step is not considered as a go/no-go check, but is used primarily as a gross leak check. If pressure decay exceeds 0.3 psid, all gas connectors, neck ring, and glove connectors should be verified locked.</p> <p>Warning tone and Hi O₂ Flow flag may come on.</p>

STEP	PROCEDURE	REMARKS
	h. Verify PGA pressure is 3.85 ± 0.15 psi and all warning flags are clear.	Clearing of the "Hi Flow" warning flag indicates leakage plus usage is less than 0.28 lb/hr when PGA pressure is at 4 psia.

BASIC DATE May 1969 CHANGE DATE June 1971 PAGE 4-48

4.5 PRESSURE INTEGRITY CHECK

STEP	PROCEDURE	REMARKS
4.6 4.6.1	PLSS NORMAL OPERATING MODES <u>PLSS Activation</u> a. Set PLSS mode selector switch to position AR. b. Set PLSS fan switch to ON. c. Don helmet and gloves. d. Set PLSS O ₂ shutoff valve to ON (down). 1. Verify low PGA pressure warning flag clear. 2. Verify 1.5 kHz tone for 10 seconds and high O ₂ flow warning flag shows 0, and then clear when PGA reaches 3.85 ± 0.15 psig. e. Set PLSS pump switch to ON. f. Verify diverter valve in the MINIMUM position. g. Set PLSS feedwater valve to OPEN (down).	PLSS/OPS donned; helmet and gloves off. A 1.5-kHz warble tone on for 10 seconds. Low-vent flow warning flag shows P. Low PGA pressure warning flag shows 0. Verify communication and TM. Verify low-vent flow warning flag clear. If fan is activated for more than 30 minutes without PGA cooling, visor fogging may occur. Low feedwater pressure warning tone on and warning flag indicates A between 1.2 and 1.7 psia cabin pressure. Ambient pressure must be below 1000μ Hg before opening valve.

STEP	PROCEDURE	REMARKS
h.	Position PLSS H ₂ O diverter valve for comfort after low feedwater pressure warning flag clears.	
4.6.2	<u>Wet Sublimator Restart</u>	PLSS operating. Ambient pressure at vacuum.
a.	Verify PLSS primary and auxiliary feedwater valve is CLOSED (up).	
b.	Verify PLSS H ₂ O diverter valve is at MAXIMUM (down).	
c.	Maintain workload to deplete feedwater rapidly.	
d.	Verify 1.5-kHz warble tone for 10 seconds. Low feedwater pressure warning flag shows A.	
e.	After 5 minutes, set PLSS H ₂ O diverter valve to MINIMUM (up).	
f.	Set PLSS primary feedwater valve to OPEN (down). Select desired diverter position after low feedwater pressure warning flag clears.	
4.6.3	<u>PLSS Deactivation</u>	EMU donned, PLSS operating. Ambient pressure at vacuum.
a.	Set PLSS primary and auxiliary water feedwater valve to CLOSED (up).	This step is performed prior to repressurization to prevent loss of feedwater when pressure is reestablished.
b.	Repressurize LM cabin.	
c.	Set PLSS O ₂ shutoff valve to OFF (up).	
d.	Set pump switch to OFF. PGA pressure is equalized with ambient. Helmet and gloves are doffed.	

4.6 PLSS NORMAL OPERATING MODES

STEP	PROCEDURE	REMARKS
	<p>e. Set fan switch to OFF.</p> <p>f. Set PLSS mode-selector switch to position 0 (OFF).</p>	

BASIC DATE May 1969 CHANGE DATE June 1971 PAGE 4-51

BASIC DATE

May 1969

CHANGE DATE June 1971

PAGE

4-52

STEP	PROCEDURE	REMARKS
4.7	<p>PLSS RECHARGE AND FEEDWATER REMOVAL PROCEDURES</p> <p>4.7.1 <u>Battery Replacement</u></p> <p>a. If RCU is connected electrically to the PLSS, all electrical controls must be in OFF position before connecting or disconnecting battery cable.</p> <p>PLSS pump switch OFF</p> <p>PLSS fan switch OFF</p> <p>PLSS mode selector switch position 0 (OFF)</p> <p>b. Rotate PLSS main battery cable 90° CCW and remove from battery. Remove protective cover from main battery cable stowage connector and stow on battery (pull knob on battery locking device outward and slide down to unlock battery).</p> <p>c. Remove old battery from PLSS and stow.</p> <p>d. Obtain replacement battery, remove dust cap, aline battery on battery foot, and slide into place in PLSS.</p> <p>e. Pull knob on battery locking device outward and slide up to lock battery.</p> <p>f. Connect PLSS main battery cable to battery.</p>	<p>The PLSS recharge procedures consist of battery replacement, LiOH cartridge change, oxygen system recharge, and feedwater reservoir recharge. Oxygen and feedwater recharge procedures are given in the LM AOH.</p>

4.7 PLSS RECHARGE AND FEEDWATER REMOVAL PROCEDURES

APOLLO OPERATIONS HANDBOOK - EMU

CSD-A-789-(2) III

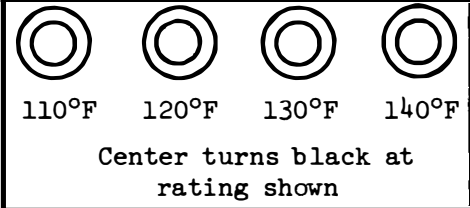
STEP	PROCEDURE	REMARKS
g. Verify battery lift strap snapped in a loop. h. Insert PLSS hose stowage strap through lift strap loop and stow. 4.7.2 <u>Removal of LiOH Cartridge From Stowage Container</u> a. Verify that green marking on indicator pin is visible on cover of stowage container. b. Lift ring and remove tape from relief valve. c. Depress relief valve button until indicator pin retracts. d. Pull ring to remove locking hooks. e. Lift off cover. f. Check temperature indicator on end of LiOH cartridge. g. Verify that 130° F temperature monitor dot is white.	Decal: <div style="border: 1px solid black; padding: 5px; text-align: center;">  <p>110°F 120°F 130°F 140°F</p> <p>Center turns black at rating shown</p> </div> Decal: <div style="border: 1px solid black; padding: 5px; text-align: center;"> <p><u>CAUTION</u></p> <p>Do not use cartridge if green marking on indicator pin is not visible.</p> </div> <div style="border: 1px solid black; padding: 5px; text-align: center;"> <p>TO OPEN:</p> <ol style="list-style-type: none"> 1. Lift ring and remove tape from relief valve. 2. Depress relief valve button until indicator pin retracts. 3. Pull ring to remove locking hooks. 4. Lift off cover. </div>	

BASIC DATE

May 1969

CHANGE DATE

June 1971

PAGE

4-54

STEP	PROCEDURE	REMARKS
4.7.3	<p><u>LiOH Cartridge Change</u></p> <ol style="list-style-type: none"> a. Verify PLSS O₂ shutoff valve is OFF. b. Remove thermal insulation from the canister cover. c. Depress cover lock. d. Rotate canister cover CCW until alinement mark on cover is alined with the open mark on canister. e. Remove cover by pulling from canister. f. Grasp drop handle and rotate contaminant control cartridge CCW until alinement marks on cartridge and canister assembly are alined. g. Pull spent contaminant cartridge out of canister. h. Obtain replacement cartridge, grasp drop handle, aline marks, and insert replacement cartridge into canister until it bottoms. i. Rotate cartridge CW approximately 90° until marks are alined to lock into position. j. Ascertain that alinement marks on both parts of the cover are alined. Grasp cover by handle and depress cover lock. k. Aline the alinement marks on canister cover with the "open" mark on cover. 	

4.7 PLSS RECHARGE AND FEEDWATER REMOVAL PROCEDURES

APOLLO OPERATIONS HANDBOOK - EMU

CSD-A-789-(2) III

STEP	PROCEDURE	REMARKS
1.	Insert cover in canister. <p style="text-align: center;"><u>CAUTION</u></p> <p style="text-align: center;">Do not force cover into canister if slightly misaligned as this may damage cover seal. First, aline cover properly.</p> m. Rotate cover CW until alinement mark on cover is alined with "closed" mark on canister. n. Resnap insulation flap over canister cover.	

BASIC DATE May 1969 CHANGE DATE June 1971 PAGE 4-55

BASIC DATE

May 1969

CHANGE DATE

June 1971

PAGE

4-56

STEP	PROCEDURE	REMARKS
4.8	<p>PURGE VALVE OPERATION</p> <p>4.8.1 <u>Activation Procedures for Purge Valve</u></p> <ol style="list-style-type: none">Remove pull pin by grasping the red apple and pulling with about 20 pounds of force.Squeeze the two locktabs on the purge valve barrel simultaneously. The valve will now pop open. <p>4.8.2 <u>Flow Adjustment Procedures</u></p> <ol style="list-style-type: none">To adjust from HIGH flow to LOW flow, depress gold button on face of purge valve and rotate until it stops (45°) in direction indicated on purge valve face (top of flange moves to crewman's left).To adjust from LOW flow to HIGH flow, depress gold button on face of purge valve and rotate until it stops (45°) in direction indicated on purge valve face (top of flange moves to crewman's right). <p>4.8.3 <u>Shutoff Procedures</u></p> <ol style="list-style-type: none">Squeeze the two locktabs simultaneously and push in the purge valve barrel.Release the locktabs while still pushing on the barrel until the locktabs are engaged.Confirm purge valve closing, either by flow changes or by visually confirming the barrel is no longer extended.	

4.8 PURGE VALVE OPERATION

STEP	PROCEDURE	REMARKS
4.8.4	<p><u>Purge Valve Removal Procedures</u></p> <p>a. Release gas connector lock-lock.</p> <p>b. Lift gas connector locktabs and rotate to release position.</p> <p>c. Remove purge valve from gas connector.</p>	

BASIC DATE May 1969 CHANGE DATE June 1971 PAGE 4-57



STEP	PROCEDURE	REMARKS
4.10 EMU INFLIGHT MAINTENANCE 4.10.1 <u>PGA and LEVA Inflight Examination and Maintenance</u> 4.10.1.1 PGA and LEVA Inflight Examination During a mission, the PGA and LEVA should be examined for wear and possible damage. A detailed examination should not be attempted unless damage to a component is suspected. If damage is obvious, a more detailed examination and analysis should be performed. The PGA and LEVA should be inspected for the following: a. Loose or broken stitches b. Rips, snags, and abraded areas c. Sharp edges and scratches d. Damaged seals or O-rings e. Proper position and security of components f. Lack of lubrication g. Cleanliness Inflight repairs on items found to be discrepant are possible in certain instances, dependent upon the provisions of the EMU maintenance kit.	This section contains procedures for examining, cleaning, lubricating, and repairing of PGA and LEVA components during flight.	

BASIC DATE May 1969 CHANGE DATE June 1971 PAGE 4-59

STEP	PROCEDURE	REMARKS
	<p>4.10.1.2 PGA and LEVA Inflight Maintenance</p> <p>a. Cleaning and antifog treatment of pressure helmet, helmet shield, and LEVA viewing areas.</p> <p>1. Cleaning of pressure helmet and helmet shield viewing areas (finger prints, smears, etc. and not lunar dust).</p> <p style="text-align: center;"><u>CAUTION</u></p> <p style="text-align: center;">This procedure should not be used on LEVA as coatings may become damaged.</p> <p>(a) Cut antifog pad container open and extract pad.</p> <p>(b) Apply heaviest possible film of solution, without causing runs, to all inside and outside viewing areas, using a continuous straight line motion.</p> <p>(c) Immediately wipe clean, and buff with drying towel from EMU maintenance kit until visibly clear.</p> <p>2. Cleaning of dust particles from the LEVA and pressure helmet</p> <p>(a) Cleaning lunar dust from LEVA in a pressurized cabin.</p> <p>(1) Blow dust off LEVA.</p> <p>(2) Pat LEVA softly (<u>DO NOT WIPE</u>) with a wet drying towel.</p>	<p>An alternate step (1) would be to brush LEVA with camera lens brush.</p>

BASIC DATE May 1969 CHANGE DATE June 1971 PAGE 4-60

4.10 EMU INFLIGHT MAINTENANCE

STEP	PROCEDURE	REMARKS
	<p>(3) Wipe LEVA softly with a clean, damp drying towel.</p> <p>(b) Cleaning lunar dust from LEVA while EVA</p> <p>NOTE: If the crewman's vision is obscured by lunar dust, raising the visor to provide visibility within the protection of the sun shade should be attempted first.</p> <p>Wipe LEVA softly with a glove gauntlet, beta bag, flag, etc.</p> <p>(c) Cleaning lunar dust from pressure helmet in a pressurized cabin.</p> <p>(1) Blow dust off pressure helmet</p> <p>(2) Pat pressure helmet softly with an antifog pad</p> <p>(3) Pat pressure helmet until dry with a drying towel.</p> <p>3. Antifog treatment of pressure helmet</p> <p>(a) Cut antifog pad container open and extract pad.</p> <p>(b) Apply heaviest possible film of solution, without causing runs, on all inside viewing areas using a continuous straight line motion.</p> <p>(c) Immediately wipe dry and buff with drying towel.</p>	

BASIC DATE

May 1969

CHANGE DATE

June 1971

PAGE

4-61

BASIC DATE May 1969

CHANGE DATE June 1971 PAGE 4-62

STEP	PROCEDURE	REMARKS
	<p>NOTE: If the pressure helmet cleaning procedure (a1) has just been completed, steps 3b and 3c may be omitted.</p>	
	<p>(d) Apply second coat as in step 3b using clean side of antifog pad.</p> <p>(e) Immediately wipe dry and buff with a new drying towel until visibly clear.</p>	<p>Coat one helmet with one pad.</p>
b.	<p>Maintenance of seals and O-rings</p>	<p>All accessible seals and O-rings may be lubricated in flight.</p>
1.	<p>Removal of seal or O-ring</p>	
(a)	<p>Fit the contoured end of the seal removal tool between the seal O-ring and seat.</p>	
(b)	<p>Rotate the tool circumferentially around until the seal O-ring is free of the recess, and remove tool and O-ring.</p>	
2.	<p>Inspection of removed seal or O-ring</p>	
(a)	<p>Inspect removed seal and O-ring for cuts, abrasions, or breaks in surface as well as irregularities in shape.</p>	
(b)	<p>If seal and O-ring are not faulty, lubricate and install. Replace if O-ring is faulty.</p>	
3.	<p>Lubrication of seal and O-ring</p>	
(a)	<p>Obtain lubrication pad from maintenance kit.</p>	

APOLLO OPERATIONS HANDBOOK - EMU
CSD-A-789-(2) III

STEP	PROCEDURE	REMARKS
3.	Remove backing from patch and place adhesive side of patch over damaged area. The patch shall be applied to inside of PGA.	
4.	Apply pressure to ensure positive bond.	
4.10.2	<u>Bioinstrumentation Inflight Repair</u>	
a.	Replacement of loose electrode	
1.	Remove all trace of old electrode paste from electrode site.	
2.	Replace existing electrode using paste P/N SEB42100014 and electrode attachment assembly P/N SEB42150035.	Located in medical accessories kit.
3.	Cover electrode with micropore covering P/N SB-AE-005408.	
b.	Replacement of electrode harness	
1.	Obtain spare electrode harness, and attach each electrode as described in step 4.8.2-a.	Located in medical accessories kit.
2.	Attach electrode harness to signal conditioners. The connectors should be finger tight.	
	<p style="text-align: center;"><u>CAUTION</u></p> <p style="text-align: center;">Do not overtighten connectors.</p>	

STEP	PROCEDURE	REMARKS
c.	Permanent removal of bioinstrumentation system Remove bioinstrumentation system and cover exposed end of the PGA electrical umbilical and/or T-adapter cable with tape P/N SEB12100050-201 (on board).	

BASIC DATE

May 1969

CHANGE DATE

June 1971

PAGE

4-65

BASIC DATE May 1969

CHANGE DATE June 1971

PAGE 4-66

STEP	PROCEDURE	REMARKS
4.11 4.11.1	MISCELLANEOUS PROCEDURES <u>PLSS Gas Trap Activation</u> a. EV activation (by other crewman) 1. Shift PLSS to extreme left. 2. Open gas trap guard. 3. Depress gas trap button for 5 seconds then release. 4. Close guard. 5. Realign PLSS. b. Pressurized cabin activation with PLSS doffed 1. Connect PLSS multiple water connector to suit connector. 2. Switch PLSS pump to ON. 3. Cycle H ₂ O diverter valve slowly (three times). 4. Switch PLSS pump to OFF. 5. Disconnect multiple water connector from suit. 6. Connect LM water supply hose to PLSS fill connector and open supply valve. 7. Open gas trap guard.	Cooling should be improved in 3 minutes.

CSD-A-789-(2) III
APOLLO OPERATIONS HANDBOOK - EMU

4.11 MISCELLANEOUS PROCEDURES :

BASIC DATE

May 1969

CHANGE DATE

June 1971

PAGE

4-67

CSD-A-789-(2)III
APOLLO OPERATIONS HANDBOOK - EMU

STEP	PROCEDURE	REMARKS
8.	Depress gas trap button until water is observed at the vent on top of the gas trap; then release.	
9.	Close guard.	
10.	Close LM water supply valve and disconnect supply hose.	
11.	Replace fill connector cap.	
12.	Close PLSS recharge access door.	
4.11.2	<u>Camera Mounting on RCU</u>	
a.	Outside LM beginning of EVA	
1.	Crewman receives camera with mounting bracket attached.	
2.	Crewman will center the camera bracket (female) at the front center of the RCU and mate the two brackets (camera and RCU halves).	
3.	Push camera and bracket down until lock is in place.	
b.	Release of camera and bracket (assumes crewman unassisted)	
1.	Place right hand under camera and bracket and apply a small force upward.	
2.	Place left thumb or forefinger on tab release lever on front of RCU.	

STEP	PROCEDURE	REMARKS
3.	Push release lever to the right while applying upward force from base of camera and lift camera from RCU mounting.	
4.11.3	<u>BSLSS Bag to PLSS Donning</u> a. Insert BSLSS tether pins into PLSS upper hard point mounts (bag is oriented so that pip pin on end of longer strap is in mounting hole near auxiliary feedwater tank). b. Depress head of tether pins and complete insertion. c. Attach doffing tethers as desired.	a. One BSLSS for two crewmen. b. Assistance of second crewman required to don BSLSS. c. Both crewmen EV on lunar surface.
4.11.4	<u>BSLSS Bag to PLSS Doffing</u> a. Grasp end of doffing tethers. b. Extend tethers until tether pins are released. c. Discard or stow BSLSS as applicable.	
4.11.5	<u>BSLSS Stowage on LRV</u> Hang the BSLSS on the back of the LMP seat on the LRV. This is done by looping the Velcro strap attached to the seat back through the BSLSS bag strap and mating with the Velcro on the front of the seat back.	BSLSS is stowed on LRV during lunar traverse and between EVA's.

STEP	PROCEDURE	REMARKS
4.11.6	<u>BSLSS Donning and Activation Procedure</u> a. Remove BSLSS assembly from stowage. b. Attach tether (adjacent to flow divider) to the left PGA LM restraint ring of crewman which has operational PLSS. c. Remove dust cover from H ₂ O flow divider. d. Disconnect PLSS H ₂ O connector from the PGA with operating PLSS. e. Connect BSLSS H ₂ O flow divider to the PGA with operational PLSS. f. Turn off pump of failed PLSS. g. Disconnect PLSS H ₂ O connector from the PGA with failed PLSS, and secure. h. Disconnect BSLSS H ₂ O connector from H ₂ O flow divider. i. Attach other tether to the right LM restraint D-ring of the crewman with nonoperational PLSS. j. Connect BSLSS H ₂ O connector to the PGA with failed PLSS. k. Connect operational PLSS water connector to H ₂ O flow divider.	Assumption: Operational PLSS on the right side of the non-operational PLSS. The following guides should be followed when attaching either of the BSLSS or PLSS water connectors to the PGA, or the PLSS water connector to the BSLSS H ₂ O flow divider. Attach H ₂ O connectors on buddy basis: a. Buddy crewman insert male connector into vacant female connector on PGA or BSLSS flow divider. b. Buddy place one arm and hand behind assisted crewman for stabilization. c. Press male connector into female connector until lock ring is actuated.
4.11.7	<u>BSLSS Disconnect Procedure</u> a. Disconnect BSLSS water connector from PGA with failed PLSS.	

STEP	PROCEDURE	REMARKS
	b. Disconnect tether from each crewman's PGA LM restraint attachment. c. Crewman with failed PLSS ready to ingress LM. d. Disconnect PLSS water connector from BSLSS water flow divider. e. Disconnect BSLSS water flow divider connector from PGA. f. Discard BSLSS. g. Connect operational PLSS water connector to PGA. h. Crewman with operational PLSS ready to ingress LM.	
	4.11.8 <u>Donning and Doffing Helmet Shield</u> 4.11.8.1 Donning Helmet Shield <p style="margin-left: 40px;">Expand shield slip hole over helmet feedport, rotate opposite side over helmet, and allow to contract into place.</p> 4.11.8.2 Doffing Helmet Shield <p style="margin-left: 40px;">Expand shield, rotate about feedport, and disengage from feedport.</p>	
	4.11.9 <u>Donning and Doffing Neck Dam</u> 4.11.9.1 Donning Neck Dam	The neck dam is donned before water egress to prevent water from entering the open neck area of the TLSA.

BASIC DATE May 1969

CHANGE DATE June 1971

PAGE 4-70

4.11 MISCELLANEOUS PROCEDURES

STEP	PROCEDURE	REMARKS
	a. Place helmet-attaching ring lock assembly in ENGAGE position. b. Slip neck dam over head so that eyelet tab is forward. c. Aline neck dam ring eyelet tab with index marks on helmet-attaching ring and snap tab in place. d. Continue pushing other tabs down into place until all tabs of neck dam are latched. e. Place the lock assembly into LOCK.	
4.11.9.2	Doffing Neck Dam	The neck dam is used only for water egress.
	a. Unlock helmet-attaching ring and separate neck-dam. b. Pull neck dam over head.	
4.11.10	<u>Insuit Drinking Device (ISDD) Installation and Use</u>	
4.11.10.1	ISDD Installation	
	a. Remove the ISDD spacecraft overwrap by cutting with scissors along one edge of the wrapper just inside any of the heat-sealed seams. Remove the device and discard the overwrap. b. Remove the PGA liner from its Velcro and snap attachments in the frontal area of the PGA neck ring.	Preferred method is to install ISDD prior to donning PGA. If gas is entrapped within the ISDD, actuate the mouthpiece tilt valve, gently squeeze the bag to expel the entrapped gas, and then allow the mouthpiece tilt valve to return to the closed position. This procedure may also be performed following 4.11.10.2.C, if required.

BASIC DATE

May 1969

CHANGE DATE

June 1971

PAGE

4-72

STEP	PROCEDURE	REMARKS
c.	Insert the ISDD (mouthpiece to crewman's left) into the PGA neck opening between the liner and suit bladder, positioning the mouthpiece as desired by crewman preference. Once positioned, press the Velcro hook of the ISDD onto the Velcro pile on the suit bladder.	
d.	Replace the liner into position, and attach the Velcro hook on the liner to the Velcro pile on the Velcro pile on the ISDD. Replace any liner snaps removed in step b that are not covered by the Velcro of the ISDD.	
e.	Proceed with PGA donning.	
4.11.10.2	ISDD Filling	
a.	Insert the water dispenser into the ISDD fill valve.	The fill valve of the ISDD is identical to that utilized on the Apollo rehydratable food packages and operates in the same manner.
b.	Depress the trigger of the water dispenser and tilt the ISDD mouthpiece tilt valve. Continue to fill the device until water venting is noted at the mouthpiece.	
c.	Release the water dispenser trigger, allow the mouthpiece tilt valve to return to the closed position, and remove the water dispenser from the ISDD fill valve.	The following alternate sequence may be utilized for ground operations and in the LM on the lunar surface between EVA periods. With the ISDD installed in the PGA, fill ISDD to the label fill line expelling entrapped gas through the mouthpiece tilt valve and then don the PGA.
d.	Proceed with pre-EVA preparations and donning of PGA helmet and gloves.	

APOLLO OPERATIONS HANDBOOK - EMU

CSD-A-789-(2) III

STEP	PROCEDURE	REMARKS
4.11.10.3	ISDD Drinking a. Turn head to the left and grasp the ISDD mouthpiece in the mouth. b. Activate the ISDD mouthpiece tilt valve by bending the mouthpiece tube, and suck water up the tube as if using a straw. c. After obtaining sufficient water, release grasp on the device mouthpiece.	The ISDD may be refilled as required in accordance with section 4.11.10.2 prior to each subsequent EVA period.
4.11.10.4	ISDD Doffing a. Remove the PGA liner from its Velcro/snap attachments and the ISDD Velcro in the frontal area of the PGA neck opening. b. Grasp the ISDD by one end of the Velcro, and remove the device from the PGA. c. Replace the PGA liner to its mating Velcro and snaps.	

BASIC DATE

May 1969

CHANGE DATE

June 1971

PAGE

4-73

STEP	PROCEDURE	REMARKS
4.11.11	OPS Oxygen Usage for Metabolic Makeup — LM and CM a. Verify OPS O ₂ connector locked in stowage plate. b. Move OPS actuation lever to ON. c. Use as required, and then move OPS actuating lever to OFF.	Flow rate in this mode is approximately 0.3 lb/hr.
4.11.12	OPS Bleed Down — LM and CM a. Verify that OPS actuation lever is OFF. b. Unstow OPS O ₂ connector from O ₂ connector stowage plate. <div style="text-align: center;"> <u>CAUTION</u> Do not unstow access flaps as they provide hose restraint. </div> c. Move OPS actuation lever to ON. d. Use as required, and then move OPS actuation lever to OFF.	Flow rate in this mode is approximately 250 lb/hr at 5880 psi.

BASIC DATE May 1969

CHANGE DATE June 1971

PAGE 4-74

CSD-A-789-(2) III
APOLLO OPERATIONS HANDBOOK - EMU

SECTION 5

EMU MALFUNCTION PROCEDURES

FOR LUNAR SURFACE EVA

5.1 INTRODUCTION

- 5.1.1 The malfunction procedures encompass the recognition, diagnosis, and corrective action for system malfunctions. In most cases, the crew is alerted to a malfunction condition by indicators and gages. The malfunction analyses do not contain solutions; such solutions are found in mission rules. The procedures in this section cover significant single failures and are not intended to replace the detailed failure modes-effects analyses published in other documents.
- 5.1.2 The malfunction procedures are for use during Apollo missions where an EMU having an SV 706100-7 PLSS will be worn. The procedures have been classified as (1) emergency, (2) EVA, and (3) post-EVA. (The post-EVA period commences when the LM cabin pressure reaches 3.5 psia.)
- 5.1.3 For maximum safety, all emergency procedures should be memorized so action can be taken immediately when the malfunction occurs. The EVA procedures do not need to be memorized since they are provided through voice communications except for steps which cover EVA procedures for loss of voice communications.
- 5.1.4 The post-EVA procedures are designed to extract a maximum amount of information on any observed anomaly since the PLSS/OPS and associated hardware would not normally be returned to earth for postflight analysis. The emergency procedures are devised so that telemetry is not used because telemetry data may not be available to the crewman. (Telemetry should be employed to aid the emergency procedures, however, if it is possible to do so.)
- 5.1.5 The procedures and remarks are representative of a nominal EMU. Values and quantities, which are characteristic of an individual EMU and which can be established only by testing the actual EMU to be used in the flight, are underlined in each case.

CSD-A-789-(2) III
APOLLO OPERATIONS HANDBOOK - EMU

5.2 FORMAT OF MALFUNCTION PROCEDURES

5.2.1 Malfunction procedures are presented in the format of logic-flow block diagrams. Diagram blocks represent procedural steps. Those blocks outlined with double lines and containing capitalized statements indicate system failures. Within blocks, statements preceded by black dots (•) indicate required actions.

5.2.2 The malfunction procedures are presented in three columns headed SYMPTOM, PROCEDURE, and REMARKS. A description and use of each of these columns is as follows:

- | | |
|-----------|--|
| SYMPTOM | The primary purpose of the symptom column is to give a first indication of the malfunction as received by either the crew or telemetry. The possible causes of the malfunction are indicated in this column. |
| PROCEDURE | The procedures column presents a step-by-step logic-flow diagram of actions and decisions used to isolate or correct a malfunction symptom. The remote-event number symbols are used to reference items to the REMARKS column or to refer to other procedural steps. |
| REMARKS | This column will include the following information:

a. Amplifying additional remarks related to the symptom, such as relief valve vents at _____psid.

b. Amplifying remarks which relate to a decision and/or action items.

c. Explaining resultant system status or operational capability after a failure has been identified.

d. Cautioning or warning, as necessary, to cover conditions that may exist because of a failure |

CSD-A-789-(2) III
APOLLO OPERATIONS HANDBOOK - EMU

5.3 MALFUNCTION SYMPTOMS FOR EMU USING PLSS SV 706100-7

Symptom	Page
EMU 1 - Warning tone ON and low vent flow flag "P" (vent-P)	5-5
EMU 2 - Warning tone ON and low PGA pressure flag "O" (PRES - "O")	5-7
EMU 3 - Warning tone ON and high O ₂ flow flag "O" (O ₂ -"O")	5-10
EMU 4 - Warning tone and low feedwater pressure flag "A" (H ₂ O-"A") while using primary feedwater	5-12
EMU 5 - Warning tone and low feedwater pressure flag "A" (H ₂ O-"A") while using auxiliary feedwater	5-14
EMU 6 - Warning tone with all warning flags CLEAR	5-16
EMU 7 - PGA pressure gage <3.7 psid and apparently stable and everything else normal	5-18
EMU 8 - PLSS O ₂ quantity indicator abnormal reading	5-19
EMU 9 - PGA pressure gage >4.0 psid	5-20
EMU 10 - Loss of pump noise	5-21
EMU 11 - Inadequate cooling of crewman	5-22
EMU 12 - EVA-1 loses voice from MSFN (EVA-1 has voice from EVA-2)	5-24
EMU 13 - EVA-1 loses voice from MSFN (EVA-1 does not receive voice from EVA-2)	5-25
EMU 14 - EVA-1 loses voice from EVA-2 (EVA-1 has voice from MSFN)	5-27
EMU 15 - EVA-2 loses voice from MSFN (EVA-2 receives voice from EVA-1)	5-29
EMU 16 - EVA-2 loses voice from MSFN (EVA-2 does not receive voice from EVA-1)	5-30
EMU 17 - EVA-2 loses voice from EVA-1 (EVA-2 has comm. with MSFN)	5-32
EMU 18 - Loss of voice comm. with EVA-1, EVA-2, or MSFN (two-man EVA) (comm. restoration procedure)	5-34
EMU 19 - EVA loses voice from LM	5-35

CSD-A-789-(2) III
APOLLO OPERATIONS HANDBOOK - EMU

Symptom	Page
EMU 20 - LM loses voice from EVA	5-37
EMU 21 - GT8168P/GT8268P PGA pressure <3.7 psid and apparently steady (no warning tone)	5-39
EMU 22 - GT8168P/GT8268P PGA pressure >4.0 psid	5-40
EMU 23 - GT8182P/GT8282P PLSS O ₂ pressure abnormal (no warning tone)	5-41
EMU 24 - GT8110P/GT8210P feedwater pressure <1.2 psia (no warning tone) while using primary feedwater	5-43
EMU 25 - GT8110P/GT8210P feedwater press. <1.2 psia (no warning tone) while using auxiliary feedwater	5-44
EMU 26 - GT8154T/GT8254T LCG H ₂ O temperature >50° F (with diverter valve in <u>MAX COOLING</u> position and no warning tone)	5-45
EMU 27 - GT8196T/GT8296T LCG H ₂ O ΔT >11° F (maximum diverter valve position)	5-46
EMU 28 - GT8140C/GT8240C PLSS battery current >3.0 A (no warning tone)	5-47
EMU 29 - GT8140C/GT8240C PLSS battery current <2.3 A (no warning tone)	5-49
EMU 30 - GT8141V/GT8241V PLSS battery voltage <16.0 V dc (no warning tone)	5-51
EMU 31 - GT8170T/GT8270T O ₂ temperature <38° F (no warning tone)	5-53
EMU 32 - GT8170T/GT8270T O ₂ temperature >50° F and rising (no warning tone)	5-54

APOLLO OPERATIONS HANDBOOK-EMU

SYMPTOM	PROCEDURE	REMARKS
	<p style="text-align: center;">POST-EVA PROCEDURE (Continued)</p> <div style="border: 1px solid black; padding: 5px; margin-bottom: 10px;"> <p>8</p> <ul style="list-style-type: none"> ● Lo vent flow sensor check ● Repressurize LM ● PLSS O₂ - OFF ● OPS O₂ - OFF ● Doff helmet and gloves ● Disconnect OPS and purge valve ● Connect blue LM ECS and red PGA gas connectors ● Connect red LM ECS and blue PGA gas connectors ● Activate ECS <30 sec <p>Low vent flow flag "P"</p> </div> <div style="display: flex; justify-content: space-around; align-items: center;"> <div style="text-align: center;"> <p>NO</p> <p>↓</p> </div> <div style="text-align: center;"> <p>YES</p> <p>→</p> </div> </div> <div style="border: 1px solid black; padding: 5px; margin-bottom: 10px; width: fit-content;"> <p>9</p> <p>LOW VENT FLOW SENSOR SHIFTED SET POINT OR FAILED CLOSED</p> </div> <div style="border: 1px solid black; padding: 5px; width: fit-content;"> <p>10</p> <p>HIGH PGA ΔP, OR FAN PERFORMANCE DEGRADED, OR SHIFT IN LOW VENT FLOW SEN OR SET POIN</p> </div>	

CSD-A-789-(2) III
 APOLLO OPERATIONS HANDBOOK-EMU

SYMPTOM	PROCEDURE	REMARKS
<p style="text-align: center;">EMU 2</p> <div style="border: 1px solid black; padding: 5px; margin-bottom: 10px;"> Warning tone ON and low PGA pressure flag "0" (PRES-"0") </div> <p>Actuating parameter: PGA pressure < 3.25 ± 0.15 psid</p> <p>Possible causes: a. EMU leak b. Low PGA pressure sensor failed ON c. PLSS O₂ regulator shifted set point or failed closed</p>	<p style="text-align: center;">EMERGENCY PROCEDURE</p> <div style="border: 1px solid black; padding: 5px; margin-bottom: 10px;"> <p style="text-align: center;">①</p> <p style="text-align: center;">1</p> <ul style="list-style-type: none"> ● Actuate OPS <p style="text-align: center;">Low PGA pressure flag CLEAR</p> <p style="text-align: right;">YES</p> <p style="text-align: center;">NO</p> </div> <div style="border: 1px solid black; padding: 5px; margin-bottom: 10px;"> <p style="text-align: center;">2</p> <p style="text-align: center;">LOW PGA PRESSURE SENSOR FAILED ON</p> </div> <p style="text-align: center;">----- EVA PROCEDURE -----</p> <div style="border: 1px solid black; padding: 5px; margin-bottom: 10px; width: 50%;"> <p style="text-align: center;">3</p> <ul style="list-style-type: none"> ● Verify PGA pressure gage and GT8168P/GT8263P PGA pressure > 3.4 psia and shut off OPS </div> <div style="border: 1px solid black; padding: 5px; margin-bottom: 10px; width: 50%;"> <p style="text-align: center;">4</p> <ul style="list-style-type: none"> ● Verify PGA pressure gage and GT8168P/GT8268P PGA pressure > 3.10 psia </div> <p style="text-align: center;">----- POST-EVA PROCEDURE -----</p> <div style="border: 1px solid black; padding: 5px;"> <p style="text-align: center;">5</p> <ul style="list-style-type: none"> ● EMU pressure integrity check <p style="text-align: center;">Verify purge vlv - CLOSED</p> <ul style="list-style-type: none"> ● OPS O₂ - OFF ● PLSS O₂ - OFF <p style="text-align: center;">Integrity all right</p> <p style="text-align: right;">YES</p> <p style="text-align: center;">NO</p> </div> <p style="text-align: center;">To step 6 next page</p> <p style="text-align: center;">To step 7 next page</p>	<p style="text-align: center;">①</p> <p>OPS regulated at 3.7 ± 0.3 psia.</p>

CSD-A-789-(2) III
 APOLLO OPERATIONS HANDBOOK EMU

SYMPTOM	PROCEDURE	REMARKS
	<p>POST-EVA PROCEDURE (Continued)</p> <pre> graph TD 6[6 ● PGA/PLSS Press. Integrity Check ● Disconnect OPS PLSS O2 - ON, then OFF Integrity all right] -- YES --> 10[10 LEAK BETWEEN OPS SHUTOFF VLV. AND PGA] 6 -- NO --> 9[9 ● PGA Press. Integrity Check ● Connect ECS to PGA ● Disconnect PLSS Hoses Integrity all right] 9 -- YES --> 13[13 LEAK BETWEEN PLSS O2 SHUT-OFF VALVE AND PGA.] 9 -- NO --> 14[14 PGA LEAK] 10 --> 12[12 ● Recharge PLSS O2] 13 --> 12 14 --> 12 15[15 DEGRADED PRESSURE REGULATOR ● RECORD GT8168P/ GT8268P PGA PRESSURE OR ● CONNECT BLUE PLSS GAS CONNECTOR TO OPS PRESSURE REGU- LATOR CHECKOUT ● STOWAGE PLATE PLSS O2 - ON ● RECORD GAGE PRESSURE] --> 11[11 ● Pressurize O2 ventilation loop ● Depress blue PLSS gas connector to vent PLSS ● Release blue PLSS gas connector ● PLSS O2 - ON, then OFF after 5 min ● Depress blue PLSS gas connector Verify PLSS O2 flow] 11 -- YES --> 17[17 PLSS O2 quantity indicator shows recharge] 11 -- NO --> 16[16 ● Recharge PLSS O2] 16 --> 17 17 -- YES --> 18[18 PLSS O2 PRESSURE REGU- LATOR FAILED (CLOSED)] 17 -- NO --> 19[19 GT8182/GT8282 PLSS O2 pressure shows recharge] 19 -- YES --> 20[20 PLSS O2 QUANTITY INDI- CATOR FAILED] 19 -- NO --> 21[21 PLSS O2 PRESSURE COMMON REDUCER FAILED] 20 --> 22[To step 22 next page] 18 --> 22 21 --> 26[To step 26 next page] </pre>	<p>① If PLSS O₂ quantity insufficient, perform integrity check with ECS.</p>

CSD-A-789-(2) III
 APOLLO OPERATIONS HANDBOOK-EMU

SYMPTOM	PROCEDURE	REMARKS
POST-EVA PROCEDURE (Continued)		
<div style="border: 1px solid black; padding: 5px; margin-bottom: 10px;"> 22 GT8182P/GT8282P PLSS O₂ pressure stable 50 min after recharge </div> <div style="margin-left: 40px;"> YES → </div> <div style="margin-left: 40px;"> NO ↓ </div> <div style="border: 1px solid black; padding: 5px; margin-top: 10px;"> 24 LEAK UPSTREAM OF PLSS O₂ SHUTOFF VALVE </div>	<div style="border: 1px solid black; padding: 5px; margin-bottom: 10px;"> 23 ● Pressurize O₂ vent loop ● PLSS gas connectors to be stowed in storage plates ● PLSS O₂ - ON GT8182P/GT8282P PLSS O₂ pressure decay after 5 minutes </div> <div style="margin-left: 40px;"> YES → </div> <div style="margin-left: 40px;"> NO ↓ </div> <div style="border: 1px solid black; padding: 5px; margin-top: 10px;"> 26 ● PLSS/PGA pressure verifi- cation ● PLSS O₂ - OFF ● Connect blue PLSS gas connector to OPS regulator pressure checkout storage plate ● PLSS O₂ - ON Checkout gage pressure <4.6 psid </div> <div style="margin-left: 40px;"> YES → </div> <div style="margin-left: 40px;"> NO ↓ </div> <div style="border: 1px solid black; padding: 5px; margin-top: 10px;"> 28 PRIMARY O₂ PRESSURE REGU- LATOR REGULATING HIGHER THAN PRV CRACKING PRESSURE </div>	<div style="border: 1px solid black; padding: 5px; margin-top: 10px;"> 25 LEAK BETWEEN PLSS O₂ SHUTOFF VALVE AND PLSS O₂ PRESSURE REGULATOR </div> <div style="margin-top: 10px;"> YES → </div> <div style="border: 1px solid black; padding: 5px; margin-top: 10px;"> 27 HIGH O₂ USAGE OR UNLOCATED LEAK </div>

APOLLO OPERATIONS HANDBOOK-EMU

SYMPTOM	PROCEDURE	REMARKS
<p>EMU 3</p> <p>Warning tone ON and high O₂ flow flag "0" (O₂-"0")</p> <p>Actuating parameter: PLSS O₂ flow >0.50 to 0.65 lb/hr for 25 sec</p> <p>Possible causes: a. EMU leak b. Primary O₂ pressure regulator regulating higher than PRV cracking pressure c. High O₂ flow sensor failed on</p>	<p>EMERGENCY PROCEDURE</p> <p>1 PA press gage <3.7 or >4.0 psid</p> <p>2 ● Actuate OPS If P A press. was <3.7 psid If PGA press. >4.0 psid ● PLSS O₂ shutoff valve - OFF</p> <p>3 PLSS O₂ quantity indicator decreasing</p> <p>4 PLSS O₂ PRESS RE REGULATOR FAILURE</p> <p>5 ● Actuate OPS</p> <hr/> <p>EVA PROCEDURE</p> <p>6 HIGH O₂ FLOW SENSOR FAI HD ON</p> <hr/> <p>POST-EVA PROCEDURE</p> <p>7 ● EMU Press. Integrity Check ● Verify purge valve - CLOSED ● OPS O₂ - OFF ● PLSS O₂ supply - OFF Integrity all right</p> <p>To step 8 next page</p> <p>To step 13 next page</p>	<p>1 Movement of the PLSS O₂ quantity indicator of approximately one-half of one division (or more) in 5 minutes will indicate high O₂ flow.</p>

CSD-A-789-(2) III
 APOLLO OPERATIONS HANDBOOK-EMU

SYMPTOM	PROCEDURE	REMARKS
	<p>POST-EVA PROCEDURE (Continued)</p> <pre> graph TD 8["8 ● PGA/PLSS Pressure integrity check ● Disconnect OPS ● PLSS O2 - ON, then OFF Integrity all right"] 9["9 LEAK BETWEEN OPS SHUTOFF VALVE AND PGA"] 10["10 ● PGA press. integrity check ● Connect ECS to PGA ● Disconnect PLSS hoses Integrity all right"] 11["11 LEAK BETWEEN HIGH O2 FLOW SENSOR AND PGA GAS CONNECTOR"] 12["12 PGA LEAK"] 13["13 Was GT8168P/ GT8268P PGA press. <4.6 psid"] 14["14 PRIMARY O2 PRESS. REGULATOR REGULATING HIGHER THAN PRV CRACKING PRESS. AND PGA PRESS. GAGE FAILED"] 15["15 HIGH O2 USAGE"] 8 -- YES --> 9 8 -- NO --> 10 10 -- YES --> 11 10 -- NO --> 12 12 --> 13 13 -- YES --> 15 13 -- NO --> 14 </pre>	<p>① If PLSS O₂ quantity insufficient, perform integrity check with ECS.</p>

CSD-A-789-(2) III
APOLLO OPERATIONS HANDBOOK - EMU

SYMPTOM	PROCEDURE	REMARKS
<p align="center">EMU-4</p> <p align="center">②</p> <p>Warning tone and low feedwater pressure flag "A" (H₂O-"A") while using primary feedwater</p> <p>Actuating parameter: Feedwater pressure <1.45 ± 0.25 psia</p> <p>Possible causes:</p> <ol style="list-style-type: none"> Sublimator breakthrough H₂O separator blocked Depleted primary feedwater reservoir Blockage at primary feedwater bladder outlet Feedwater pressure sensor failed on Primary H₂O shutoff and relief valve closed 	<p align="center">EVA PROCEDURE</p> <pre> graph TD Start(()) --> B1[1 Is primary H2O shutoff and relief valve open] B1 -- YES --> B2[2 GT8110F/GT8210F feedwater pressure <1.2 psia, and GT8170T/GT270T O2 temp >50° F and rising] B1 -- NO --> B4[4 PRIMARY H2O SHUTOFF AND RELIEF VALVE CLOSED] B2 -- YES --> B3[3 GT8154/GT8254T LCG H2O temp >50° F and rising GT8196T/GT8296T LCG H2O ΔT <5° F and decreasing (H2O diverter in MAX. COOLING)] B2 -- NO --> B5[5 LOW FEEDWATER PRESSURE SWITCH FAILED] B3 -- YES --> B6[6 SUBLIMATOR BREAKTHROUGH] B3 -- NO --> B8[8 Sublimator restart • Primary H2O shutoff and relief valve - CLOSED • H2O diverter valve - MAX. • After 5 min H2O diverter valve - MIN. • Primary H2O shutoff and relief valve - OPEN Low feedwater pressure flag CLEAR after 4 min] B4 --> B7[7 H2O diverter valve - MIN. • Primary H2O shutoff and relief valve - OPEN (Wait 4 min or until flag clears before changing diverter valve position)] B5 --> B7 B6 --> B8 B7 --> B8 B8 --> B9[9 If additional cooling is required • H2O diverter valve - MIN. • Auxiliary h2O shutoff and relief valve - OPEN (wait 4 min or until flag clears before changing diverter valve position) Cooling improved or low feedwater pressure flag CLEAR within 4 min] B9 -- YES --> B8 B9 -- NO --> B10[10 If additional cooling is required, activate BSLSS] B10 --> B8 </pre>	<p align="center">①</p> <p>Actuation of the OPS and opening of the purge valve to HIGH flow may also be used if BSLSS is not carried. If PLSS O₂ valve remains open during purge mode, POS consummables may be depleted.</p> <p align="center">②</p> <p>It is assumed that <u>normal</u> feedwater depletion has not occurred.</p> <p align="center">③</p> <p>The heat load should be maintained during the first 5 minutes since the objective is to dry out the sublimator.</p>

APOLLO OPERATIONS HANDBOOK-EMU

SYMPTOM	PROCEDURE	REMARKS
	<p style="text-align: center;">POST-EVA PROCEDURE</p> <div style="display: flex; justify-content: space-around; align-items: flex-start;"> <div style="border: 1px solid black; padding: 5px; width: 20%;"> <p>11 BLOCKAGE AT PRIMARY FEEDWATER BLADDER OUTLET</p> </div> <div style="border: 1px solid black; padding: 5px; width: 30%;"> <p>12</p> <ul style="list-style-type: none"> ● Pressurize backside of feedwater bladder from O₂ vent loop ● Connect LM waste management system to PLSS primary vent connector ● Close auxiliary H₂O shutoff and relief valve ● Hoses disconnected from PGA ● PLSS O₂ - ON <p>Feedwater expelled through primary feedwater vent connector</p> </div> </div> <p style="text-align: center;">YES</p> <div style="display: flex; justify-content: space-around; align-items: flex-start;"> <div style="border: 1px solid black; padding: 5px; width: 20%;"> <p>14 PRIMARY FEEDWATER RESERVOIR DEPLETED</p> </div> <div style="border: 1px solid black; padding: 5px; width: 30%;"> <p>13</p> <ul style="list-style-type: none"> ● Connect LM waste mgmt. system to drain connector <p>Drain H₂O or O₂ expelled from H₂O drain connector</p> </div> </div> <p style="text-align: center;">NO</p> <div style="border: 1px solid black; padding: 5px; width: 20%; margin-left: auto;"> <p>15 WATER SEPARATOR BLOCKED</p> </div>	

CSD-A-789-(2) III
APOLLO OPERATIONS HANDBOOK-EMU

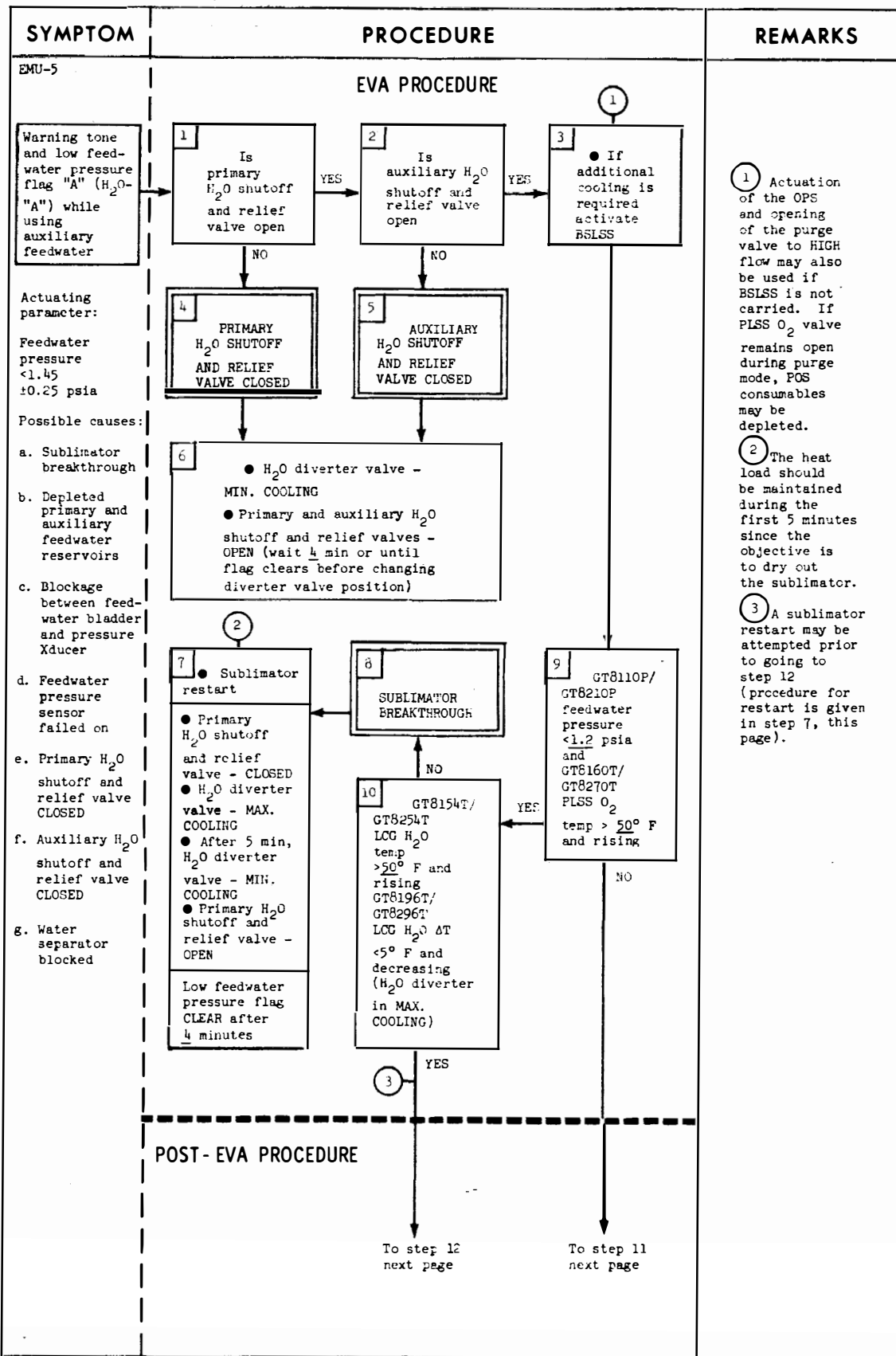

CSD-A-789-(2) III
 APOLLO OPERATIONS HANDBOOK-EMU

SYMPTOM	PROCEDURE	REMARKS
POST-EVA PROCEDURE		
<div style="border: 1px solid black; padding: 5px; margin-bottom: 10px;"> 11 LOW FEEDWATER PRESSURE SWITCH FAILED </div> <div style="border: 1px solid black; padding: 5px;"> 13 BLOCKAGE BETWEEN BLADDER AND FEEDWATER PRESSURE XDUCEM </div>	<div style="border: 1px solid black; padding: 5px; margin-bottom: 10px;"> 12 <ul style="list-style-type: none"> ● Pressurize backside of feedwater bladder from O₂ vent loop ● Connect LM waste management system to PLSS auxiliary feedwater vent connector ● Hoses disconnected from PGA ● PLSS O₂ - ON Feedwater expelled through auxiliary feedwater vent connector </div> <div style="border: 1px solid black; padding: 5px; margin-bottom: 10px;"> 14 BOTH FEEDWATER RESERVOIRS DEPLETED </div> <div style="border: 1px solid black; padding: 5px; margin-bottom: 10px;"> 15 <ul style="list-style-type: none"> ● Connect LM waste management system to PLSS H₂O drain connector Drain H₂O or O₂ expelled from PLSS H₂O drain connector </div> <div style="border: 1px solid black; padding: 5px;"> 16 WATER SEPARATOR BLOCKED </div>	
	YES → NO ↓	
	YES → NO ↓	

CSD-A-789-(2) III
APOLLO OPERATIONS HANDBOOK-EMU

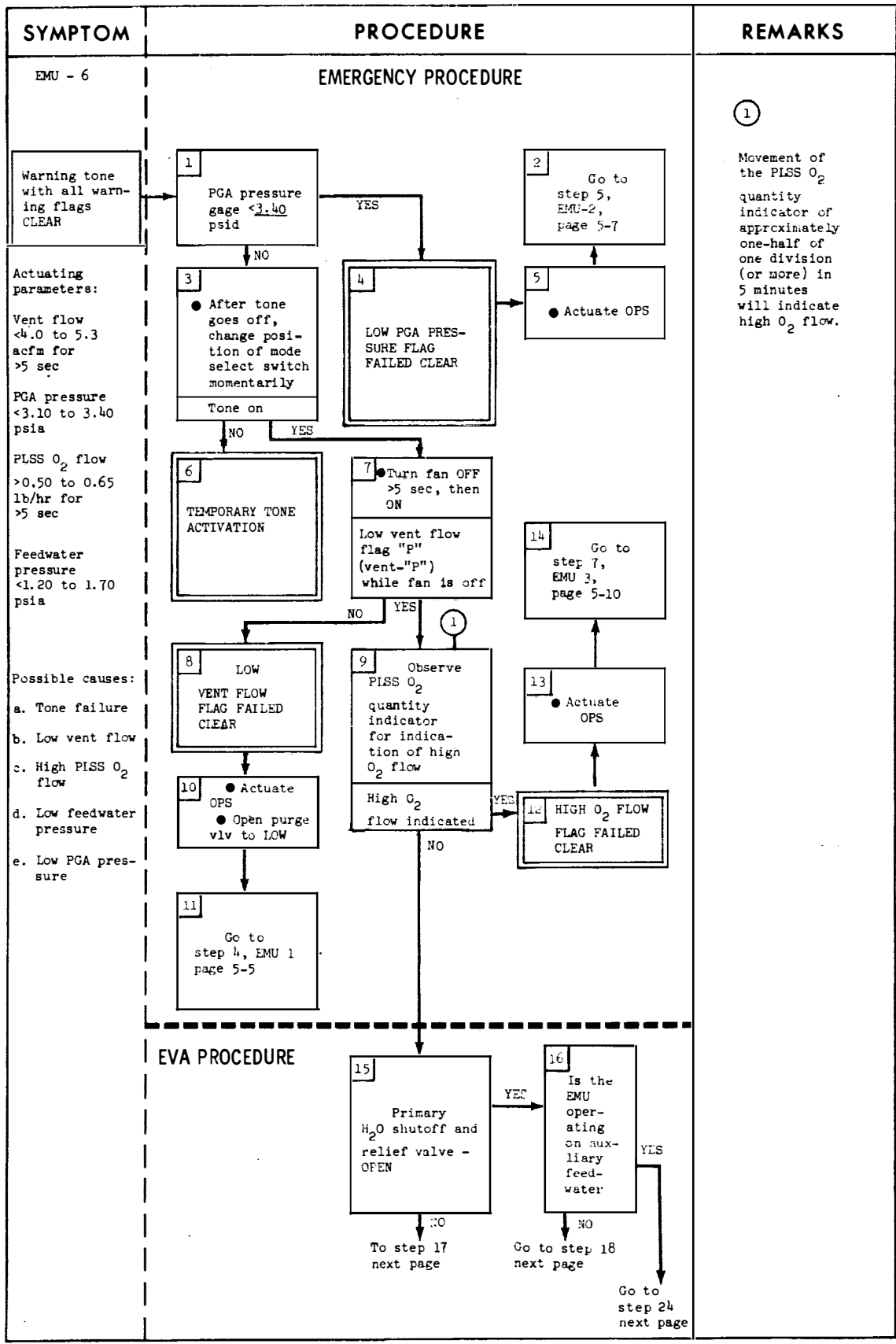

CSD-A-789-(2) III
APOLLO OPERATIONS HANDBOOK - EMU

SYMPTOM	PROCEDURE	REMARKS
EVA PROCEDURE (Continued)		
<div style="border: 1px solid black; padding: 5px; margin-bottom: 10px;"> 17 LOW FEED- WATER PRESSURE FLAG FAILED CLEAR </div> <div style="border: 1px solid black; padding: 5px; margin-bottom: 10px;"> 20 <ul style="list-style-type: none"> ● H₂O diverter valve - MIN. ● Open primary H₂O shutoff and relief valve ● Wait ½ min before changing H₂O diverter valve position </div> <div style="border: 1px solid black; padding: 5px; margin-bottom: 10px;"> 23 LOW FEED- WATER PRESSURE FLAG FAILED CLEAR </div> <div style="border: 1px solid black; padding: 5px;"> 25 <ul style="list-style-type: none"> ● H₂O diverter valve - MIN. ● Open auxiliary H₂O shutoff and relief valve ● Wait ½ min before changing H₂O diverter valve position </div>	<div style="border: 1px solid black; padding: 5px; margin-bottom: 10px;"> 18 GT8110P/GT8210P feedwater pressure <1.2 psia, and GT8170T/GT8270T O₂ temp >50° F and rising </div> <div style="border: 1px solid black; padding: 5px; margin-bottom: 10px;"> 21 WARNING TONE FAILED (CAME ON WHEN THERE WAS NO CAUSE) </div> <div style="border: 1px solid black; padding: 5px; margin-bottom: 10px;"> 24 Auxiliary H₂O shutoff and relief valve - OPEN </div> <div style="border: 1px solid black; padding: 5px; margin-bottom: 10px;"> 26 FEED- WATER PRESSURE FLAG FAILED CLEAR </div> <div style="border: 1px solid black; padding: 5px; margin-bottom: 10px;"> 28 <ul style="list-style-type: none"> ● If additional cooling is required, activate BSLSS </div> <div style="border: 1px solid black; padding: 5px;"> 29 Go to step 10, EMU 5, page 5-14 </div>	<div style="border: 1px solid black; padding: 5px; margin-bottom: 10px;"> 19 FEEDWATER PRESS. FLAG FAILED CLEAR </div> <div style="border: 1px solid black; padding: 5px; margin-bottom: 10px;"> 22 Go to step 3, EMU 4, page 5-12 </div> <div style="border: 1px solid black; padding: 5px; margin-bottom: 10px;"> 27 GT8110P/GT8210P feedwater press. <1.2 psia and GT8170T/GT8260T O₂ temp >50° F and rising </div>
<div style="border: 1px solid black; border-radius: 50%; width: 20px; height: 20px; display: flex; align-items: center; justify-content: center; margin-bottom: 5px;">1</div> Actuation of the OPS and opening of the purge valve to HIGH flow may also be used if BSLSS is not carried. If PLSS O ₂ valve remains open during purge mode, POS consumables may be depleted.		

CSD-A-789-(2) III
 APOLLO OPERATIONS HANDBOOK-EMU

SYMPTOM	PROCEDURE	REMARKS
<p>EMU - 7</p> <div style="border: 1px solid black; padding: 5px; margin: 10px 0;"> <p style="text-align: center;">①</p> <p>PGA pressure gage <3.7 psid and apparently stable and everything else normal</p> </div> <p>Possible causes;</p> <p>a. Gage shift or failure</p> <p>b. PLSS O₂ regulator shift/degraded</p>	<p style="text-align: center;">EMERGENCY PROCEDURE</p> <div style="border: 1px solid black; padding: 5px; margin: 10px 0;"> <p style="text-align: center;">1</p> <p>● Actuate the OPS</p> <p>Does PGA pressure gage respond</p> </div> <p style="text-align: center;">YES</p> <div style="border: 1px solid black; padding: 5px; margin: 10px 0;"> <p style="text-align: center;">2</p> <p>PGA PRESSURE GAGE FAILED</p> </div> <p style="text-align: center;">NO</p> <hr style="border-top: 1px dashed black;"/> <p style="text-align: center;">EVA PROCEDURE</p> <div style="border: 1px solid black; padding: 5px; margin: 10px 0;"> <p style="text-align: center;">3</p> <p>Verify GT8168P/ GT8268P PGA pressure >3.7 psid</p> </div> <div style="border: 1px solid black; padding: 5px; margin: 10px 0;"> <p style="text-align: center;">4</p> <p>● Turn off OPS</p> </div> <div style="border: 1px solid black; padding: 5px; margin: 10px 0;"> <p style="text-align: center;">5</p> <p>PLSS O₂ REGULATOR SHIFTED SET POINT</p> </div>	<div style="border: 1px solid black; padding: 5px; margin: 10px 0;"> <p style="text-align: center;">②</p> <p>PLSS O₂ pressure regulator regulates the PGA to 3.7 psid minimum if flow is 0.07 to 0.7 lb/hr.</p> </div>

APOLLO OPERATIONS HANDBOOK-EMU

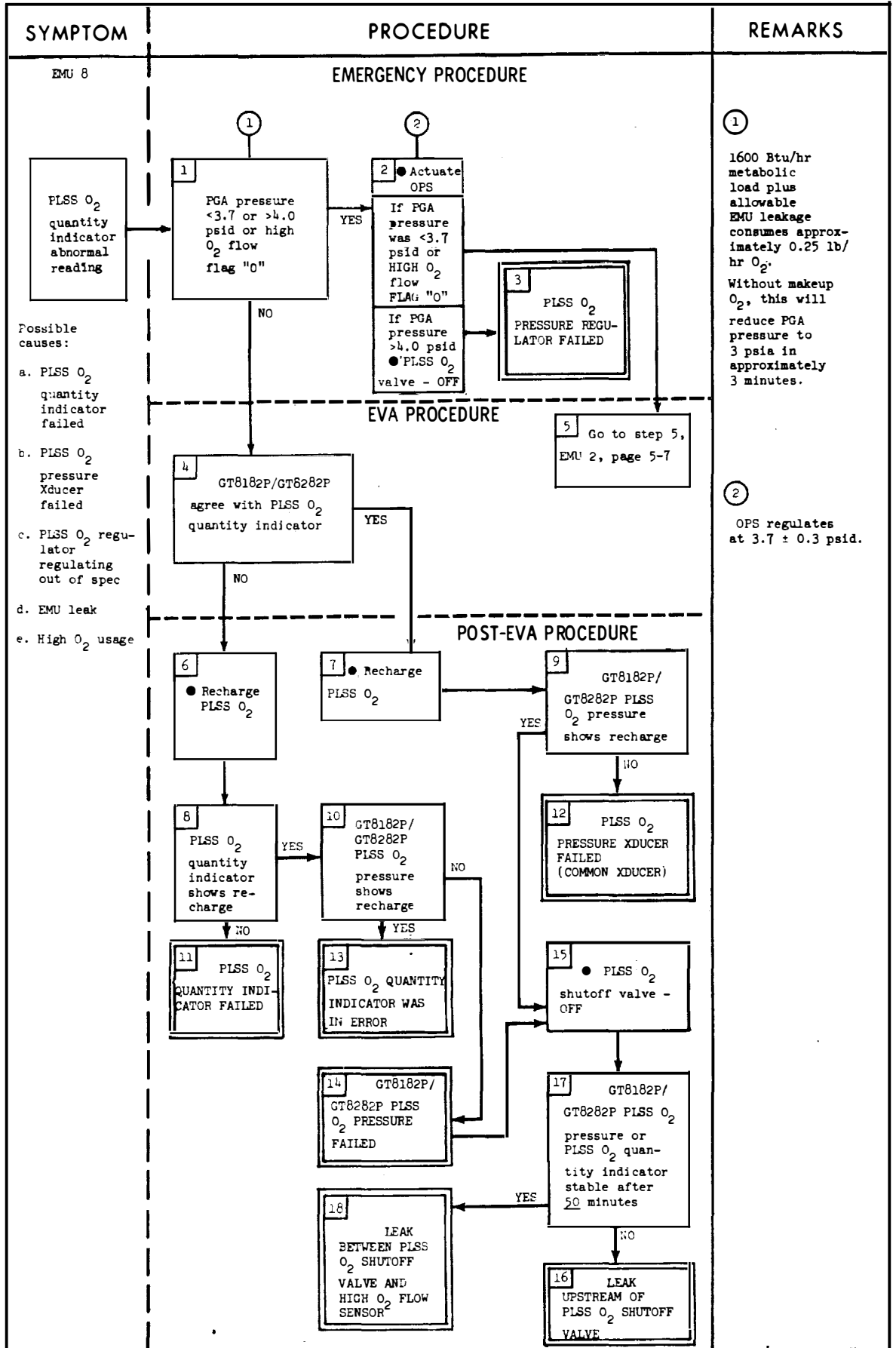

APOLLO OPERATIONS HANDBOOK-EMU

SYMPTOM	PROCEDURE	REMARKS
<p>EMU 9</p> <p>①</p> <p>PGA pressure gage >4.0 psid</p> <p>Possible causes:</p> <p>a. Regulator fails open or shifts set point</p> <p>b. PGA pressure gage fails</p>	<p style="text-align: center;">EMERGENCY PROCEDURE</p> <p>②</p> <p>1 High O₂ flow flag "0" (after 5 sec) or PLSS O₂ quantity indicator decreasing</p> <p>2</p> <ul style="list-style-type: none"> ● Actuate OPS ● Close PLSS O₂ shutoff valve if possible <p>3</p> <p>PLSS O₂ PRESS. REGULATOR FAILED OPEN OR SHIFTED SET POINT</p> <hr/> <p style="text-align: center;">EVA PROCEDURE</p> <p>③</p> <p>4 Does GT8168P/GT8268P PGA press. agree with PGA press. gage</p> <p>5</p> <p>SHIFT IN PLSS O₂ REGULATED PRESSURE</p> <hr/> <p style="text-align: center;">POST-EVA PROCEDURE</p> <p>6</p> <ul style="list-style-type: none"> ● Connect blue PLSS gas connector to OPS regulator checkout stowage plate <p>Does OPS gage agree with PGA gage</p> <p>7</p> <p>GT8168P/GT8268P PGA PRESS. FAILED</p> <p>8</p> <p>PGA PRESS. GAGE FAILED</p>	<p>①</p> <p>PLSS O₂ pressure regulator regulates to 4.0 psid maximum to PGA. PGA pressure relief valve cracks at 5.0 to 5.75 psid.</p> <p>②</p> <p>If additional mobility is needed, open purge valve to reduce PGA pressure to >3.4 psid.</p> <p>③</p> <p>An additional indication of high PGA pressure would be reduced PGA mobility.</p>

APOLLO OPERATIONS HANDBOOK-EMU

SYMPTOM	PROCEDURE	REMARKS
<p>EMU 10</p> <p>Loss of pump noise</p> <p>Possible causes:</p> <p>a. Pump switch OFF</p> <p>b. Power failure</p> <p>c. Open RCU connection</p> <p>d. Pump failure</p>	<p style="text-align: center;">EMERGENCY PROCEDURE</p> <pre> graph TD Start[Loss of pump noise] --> 1[1 Receiving sidetone] 1 -- YES --> 2[2 Actuate OPS and purge valve-LOW FLOW and activate BSLSS] 1 -- NO --> 2 2 --> 3[3 Pump switch ON] 3 -- YES --> 5[5 GTB140C/ GTB240C PLSS battery current <1.9 A] 3 -- NO --> 4[4 PUMP SWITCHED OFF] 5 -- YES --> 6[6 PUMP MOTOR FAILED (OPEN CIRCUIT)] 5 -- NO --> 7[7 PUMP SEIZED OR SLOWED] 6 --> 8[8 If additional cooling is required activate BSLSS] 7 --> 8 2 --> 9[9 Is RCU connection properly mated] 9 -- YES --> 10[10 MAIN POWER FAILED] 9 -- NO --> 11[11 OPEN RCU CONNECTION] </pre> <p style="text-align: center;">EVA PROCEDURE</p> <p style="text-align: center;">POST-EVA PROCEDURE</p>	<p>①</p> <p>ACTUATION of OPS and opening of purge valve to HIGH FLOW may also be used if BSLSS is not carried. If PLSS O₂ shutoff valve remains open during purge valve operation, POS consumables may be depleted.</p>

CSD-A-789-(2) III
APOLLO OPERATIONS HANDBOOK-EMU

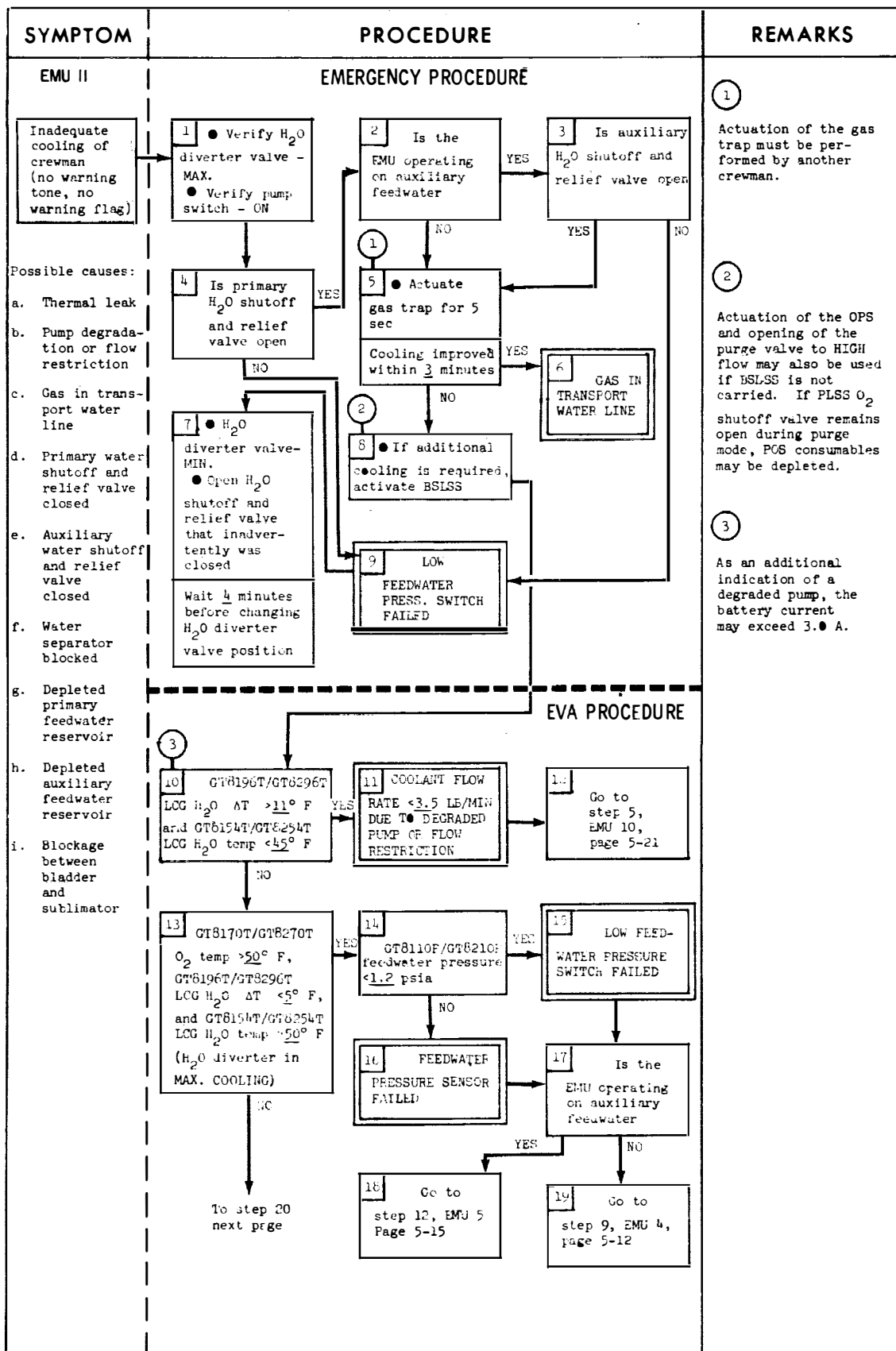

CSD-A-789-(2) III
 APOLLO OPERATIONS HANDBOOK-EMU

SYMPTOM	PROCEDURE	REMARKS
	<p>EVA PROCEDURE (Continued)</p> <div style="border: 1px solid black; padding: 5px; margin-bottom: 10px;"> <div style="border: 1px solid black; padding: 2px; display: inline-block; width: 20px; text-align: center;">20</div> <p style="margin: 0;">EXCESSIVE THERMAL LEAK INTO EMU</p> </div> <p style="text-align: center;">↓</p> <div style="display: flex; justify-content: space-between;"> <div style="border: 1px solid black; padding: 5px; width: 45%;"> <div style="border: 1px solid black; padding: 2px; display: inline-block; width: 20px; text-align: center;">21</div> <p style="margin: 0;">● Check LEVA position, latch and interface collar, and adjust as required</p> <p style="margin: 0;">Cooling improved</p> </div> <div style="width: 5%; text-align: center;"> <p>YES →</p> </div> <div style="border: 1px solid black; padding: 5px; width: 45%;"> <div style="border: 1px solid black; padding: 2px; display: inline-block; width: 20px; text-align: center;">22</div> <p style="margin: 0;">LEVA HEAT LEAK</p> </div> </div> <p style="text-align: center;">↓ NO</p> <div style="border: 1px solid black; padding: 5px; width: 100%;"> <div style="border: 1px solid black; padding: 2px; display: inline-block; width: 20px; text-align: center;">23</div> <p style="margin: 0;">EMU INSULATION HEAT LEAK</p> </div>	

APOLLO OPERATIONS HANDBOOK-EMU

SYMPTOM	PROCEDURE	REMARKS
<p>EMU 12</p> <p>EVA-1 loses voice from MSFN (see "Additional conditions" below)</p> <p>Additional conditions: 1. Dual EVA 2. EVA-1 has voice from EVA-2</p> <p>Possible causes: a. LM or MSFN failed b. EVA-1 "A" volume control turned too low c. EVA-1 R/T relay K-1 failed closed in backup mode d. Triplexer "A" section failed e. EVA-1 "A" receiver RF section failed f. EVA-1 triplexer "A" section, "A" receiver, or R/T relay K-1 failed open in both modes g. EVA-1 "A" receiver audio section failed h. Receiver "A" RCU volume control failed</p>	<p>EVA PROCEDURE</p> <pre> graph TD Start[EVA-1 loses voice from MSFN] --> Step1{1 Does EVA-2 receive voice from MSFN} Step1 -- YES --> Step2{2 Does EVA-1 have side-tone} Step1 -- NO --> Step4{4 LM OR MSFN FAILED} Step2 -- YES --> Step3{3 • Set EVA-1 mode sel. SW. at "B" • Set EVA-2 mode sel. SW at "A"} Step2 -- NO --> Step5{5 • EVA-1 set RCU "A" volume control to max. Comm. restored} Step3 --> Step6{6 Does EVA-2 receive voice from EVA-1} Step5 --> Step6 Step6 -- YES --> Step5 Step6 -- NO --> Step8{8 EVA-1 R/T RELAY K-1 FAILED OPEN IN BOTH MODES, OR TRIPLEXER "A" SECTION FAILED} Step8 --> Step9{9 EVA-1 R/T RELAY K-1 FAILED CLOSED IN MODE "B", OR "A" RECEIVER RF SECTION FAILED} </pre> <p>POST-EVA PROCEDURE</p> <pre> graph TD Step5 --> Step10{10 • Swap EVA-1 RCU with EVA-2 EVA-1 receive on "A" receiver} Step10 -- YES --> Step11{11 RECEIVER "A" RCU VOLUME CONTROL FAILED} Step10 -- NO --> Step12{12 EVA-1 "A" RECEIVER FAILED} </pre>	

CSD-A-789-(2) III
 APOLLO OPERATIONS HANDBOOK-EMU

SYMPTOM	PROCEDURE	REMARKS
<p>EMU-13</p> <p>EVA-1 loses voice from MSFN (see "Additional conditions" below)</p> <p>Additional conditions:</p> <ol style="list-style-type: none"> 1. Dual EVA 2. EVA-1 does not receive voice from EVA-2 <p>Possible causes:</p> <ol style="list-style-type: none"> a. Comm. carrier failed b. RCU mode selector "A" section failed c. RCU cable failed d. Primary dual comm. regulator failed e. PLSS electrical umbilical failed f. Antenna or triplexer common port failed g. J-3 Pin 8 failed 	<p style="text-align: center;">EVA PROCEDURE</p> <div style="border: 1px solid black; padding: 5px; margin-bottom: 5px;"> <p>1</p> <p>Does EVA-1 have sidetone</p> <p>YES → [To step 13 next page]</p> <p>NO → 2</p> </div> <div style="border: 1px solid black; padding: 5px; margin-bottom: 5px;"> <p>2</p> <ul style="list-style-type: none"> • EVA-1 set mode sel. SW. in "A" position <p>Comm. restored with MEFN</p> <p>YES → [To step 13 next page]</p> <p>NO → 4</p> </div> <div style="border: 1px solid black; padding: 5px; margin-bottom: 5px;"> <p>3</p> <p>RCU MODE SELECTOR DUAL CONTACT "A" WAFER FAILED</p> </div> <div style="border: 1px solid black; padding: 5px; margin-bottom: 5px;"> <p>4</p> <ul style="list-style-type: none"> • EVA-1 set mode sel. SW. in position "B" <p>Does EVA-1 hear sidetone</p> <p>YES → 5</p> <p>NO → 6</p> </div> <div style="border: 1px solid black; padding: 5px; margin-bottom: 5px;"> <p>5</p> <ul style="list-style-type: none"> • EVA-1 mode sel. SW. in pos. "B" • EVA-2 mode sel. SW. in pos. "A" <p>→ [To step 13 next page]</p> </div> <div style="border: 1px solid black; padding: 5px; margin-bottom: 5px;"> <p>6</p> <ul style="list-style-type: none"> • EVA-1 PLSS fan - OFF >5 sec <p>EVA-1 hear warning tone</p> <p>YES → 7</p> <p>NO → 8</p> </div> <div style="border: 1px solid black; padding: 5px; margin-bottom: 5px;"> <p>7</p> <p>RCU MODE SELECTOR "A" WAFER FAILED</p> </div> <div style="border: 1px solid black; padding: 5px; margin-bottom: 5px;"> <p>8</p> <p>EVA-1 low vent flow flag "P" while fan is OFF</p> <p>NO → 9</p> <p>YES → [To step 16 next page]</p> </div> <div style="border: 1px solid black; padding: 5px;"> <p>9</p> <p>RCU J-3 PIN 8 FAILED</p> <p>→ [To step 18 next page]</p> </div>	

APOLLO OPERATIONS HANDBOOK-EMU

SYMPTOM	PROCEDURE	REMARKS	
POST-EVA PROCEDURE			
	<div style="border: 1px solid black; padding: 5px; margin-bottom: 10px;"> <p>10</p> <ul style="list-style-type: none"> ● Swap EVA-1 comm. carrier with EVA-2 <p>Comm. restored</p> </div>		
	YES →		
		NO ↓	
	YES →		
	NO ↓		
	YES →		
	NO ↓		
	YES →		
	NO ↓		
	YES →		
NO ↓			
YES →			
NO ↓			

APOLLO OPERATIONS HANDBOOK-EMU

SYMPTOM	PROCEDURE	REMARKS
<p>EMU 14</p> <p>EVA-1 loses voice from EVA-2 (see "Additional conditions" below)</p> <p>Additional conditions:</p> <ol style="list-style-type: none"> 1. EVA-1 has voice from MSFM 2. Dual EVA <p>Possible causes:</p> <ol style="list-style-type: none"> a. EVA-1 B/C volume control set too low b. EVA-1 "B" receiver audio section failed c. EVA-2 PTT switch was OFF d. EVA-2 R/T relay K-2 failed closed in "A" position e. FM link failed f. Audic section of signal processor failed <p>(Continued on next page)</p>	<p>EVA PROCEDURE</p> <pre> graph TD Start[EVA-1 loses voice from EVA-2] --> Step1[1 • EVA-1 set RCU B/C volume to MAX. Comm. restored] Step1 -- YES --> Step2[2 VOLUME CONTROL WAS TURNED TOO LOW] Step1 -- NO --> Step3[3 Does MSFM hear EVA-2 and re- ceive TM from EVA-2] Step3 -- YES --> Step4[4 EVA-1 "B" RCVR. AUDIO SECTION FAILED] Step3 -- NO --> Step5[5 Does MSFM re- ceive TM but no voice from EVA-2] Step5 -- YES --> Step6[6 • EVA-2 switch PTT OFF/MAIN Comm. restored] Step6 -- YES --> Step7[7 EVA-2 PTT SWITCH WAS OFF] Step6 -- NO --> Step9[9 • EVA-2 go to MOM from MAIN. Comm. restored] Step5 -- NO --> Step8[8 • EVA-2 mode sel. SW. - pos. "B" Comm. restored] Step8 -- YES --> Step9 Step8 -- NO --> Step10[10 EVA-2 R/T RE- LAY K-2 FAILED CLOSED IN "A" POSITION] Step10 --> Step11[11 FM LINK FAILED] Step9 --> Next15[To step 15 next page] Step9 --> Next12[To step 12 next page] </pre>	

APOLLO OPERATIONS HANDBOOK-EMU

SYMPTOM	PROCEDURE	REMARKS
<p>Possible causes: (continued)</p> <p>g. PTT circuit in EVA-2 RCU failed</p> <p>h. PTT circuit in EVA-2 PLSS failed</p> <p>i. EVA-2 comm. carrier failed</p>	<p style="text-align: center;">POST-EVA PROCEDURE</p> <pre> graph TD 12["12 ● Swap EVA-2 RCU with EVA-1 Comm. restored"] -- YES --> 13["13 MAIN CONTACTS OF PTT SWITCH IN EVA-2 RCU FAILED"] 12 -- NO --> 14["14 PRIMARY VOX CIRCUIT IN EVA-2 PLSS FAILED"] 14 --> 15["15 ● Swap EVA-1 comm. carrier with EVA-2 Comm. restored"] 15 -- YES --> 16["16 EVA-2 COMM. CARRIER FAILED"] 15 -- NO --> 17["17 AUDIO SECTION OF SIGNAL PROCESSOR FAILED"] </pre>	

APOLLO OPERATIONS HANDBOOK-EMU

SYMPTOM	PROCEDURE	REMARKS
<p>EMU 15</p> <p>EVA-2 loses voice from MSFN (see "Additional conditions" below)</p> <p>Additional conditions:</p> <ol style="list-style-type: none"> 1. Dual EVA 2. EVA-2 receives voice from EVA-1 <p>Possible causes:</p> <ol style="list-style-type: none"> a. "A" volume control turned too low or failed b. LM or MSFN failed c. EVA-2 "A" receiver RF section failed d. EVA-2 "A" section triplexer failed e. EVA-2 "A" receiver failed 	<p>EVA PROCEDURE</p> <pre> graph TD Start[EVA-2 loses voice from MSFN] --> 1{1 Does EVA-1 receive voice from MSFN} 1 -- YES --> 2{2 EVA-2 set RCU "A" volume control to MAX. Comm. restored} 1 -- NO --> 4{4 LM OR MSFN FAILED} 2 -- YES --> 3{3 EVA-2 "A" VOLUME CONTROL TURNED TOO LOW} 2 -- NO --> 5{5 EVA-2 set mode sel. SW. at "A". Does EVA-2 have sidetone} 5 -- YES --> 7{7 EVA-2 set mode sel. SW at "B". EVA-1 set mode sel. SW. at "A". EVA-1 has comm. with EVA-2} 5 -- NO --> 6{6 EVA-2 "A" RECEIVER RF SECTION FAILED} 7 -- YES --> 6 7 -- NO --> 8{8 EVA-2 "A" SECTION TRIPLEXER FAILED} 6 --> 9{9 Swap EVA-1 RCU with EVA-2. EVA-2 comm. with MSFN restored} 9 -- YES --> 10{10 EVA-2 RCU "A" VOLUME CIRCUIT FAILED} 9 -- NO --> 11{11 EVA-2 "A" RECEIVER FAILED} </pre> <p>POST EVA PROCEDURE</p>	

APOLLO OPERATIONS HANDBOOK-EMU

SYMPTOM	PROCEDURE	REMARKS
<p>EMU 16:</p> <p>EVA-2 loses voice from MSFN (see "Additional conditions" below)</p> <p>Additional conditions:</p> <ol style="list-style-type: none"> 1. Dual EVA 2. EVA-2 does not receive voice from EVA-1 <p>Possible causes:</p> <ol style="list-style-type: none"> a. RCU mode selector dual contact failed b. RCU mode selector switch "A" wafer failed c. RCU P-3 pin 8 failed <p>(Continued on next page)</p>	<p align="center">EVA PROCEDURE</p> <pre> graph TD S1[1] -- NO --> S2[2] S1 -- YES --> R1[To step 17 next page] S2 -- YES --> B3[3] S2 -- NO --> S4[4] S4 -- YES --> B5[5] S4 -- NO --> S6[6] S6 -- YES --> B7[7] S6 -- NO --> S8[8] S8 -- YES --> R2[To step 10 next page] S8 -- NO --> B9[9] B3 --> R3[To step 12 next page] B5 --> R3 B7 --> R3 B9 --> R3 </pre> <p>1 Does EVA-1 have sidetone</p> <p>2 ● EVA-2 set mode sel. SW. in "A" position MSFN comm. restored</p> <p>3 RCU MODE SEL. DUAL CONTACT "A" WAFER FAILED</p> <p>4 ● EVA-2 set mode sel. SW. to "B" Does EVA-2 hear sidetone</p> <p>5 ● EVA-2 mode sel. SW. to "B" ● EVA-1 mode sel. SW. to "A"</p> <p>6 ● EVA-2 Fan OFF >5 sec then ON EVA-2 hear warning tone</p> <p>7 RCU MODE SEL. SW. "A" WAFER FAILED</p> <p>8 EVA-2 low vent flow warning flag "P"</p> <p>9 RCU P-3 PIN 8 FAILED</p>	

APOLLO OPERATIONS HANDBOOK-EMU

SYMPTOM	PROCEDURE	REMARKS
POST-EVA PROCEDURE		
<p>d. PLSS electrical umbilical failed</p> <p>e. EVA-2 comm. carrier failed</p> <p>f. EVA-2 triplexer failed</p> <p>g. EVA-2 suit electrical harness failed</p> <p>h. RCU mode selector switch dual and primary contact "A" wafer failed</p> <p>i. Primary/dual comm. regulator failed</p> <p>j. EVA-2 antenna or cable failed</p>	<pre> graph TD 10["10 ●EVA-2 connect to IM umbilical MSFN comm. all right"] -- YES --> 11["11 PLSS ELEC- TRICAL UMBIL- ICAL FAILED"] 10 -- NO --> 13["13 ●EVA-2 swap comm. carrier with EVA-1 MSFN comm. all right"] 11 -- YES --> 20["20 EVA-2 ANTENNA OR CABLE FAILED"] 11 -- NO --> 15["15 EVA-2 TRI- PLEXER FAILED"] 13 -- YES --> 14["14 EVA-2 COMM. CARRIER FAILED"] 13 -- NO --> 16["16 EVA-2 SUIT ELECTRICAL HARNESS FAILED"] 14 -- YES --> 18["18 RCU MODE SEL. SW. DUAL AND PRIMARY CON- TACT "A" WAFER FAILED"] 14 -- NO --> 19["19 PRIMARY/DUAL COMM. REGU- LATOR FAILED"] 16 --> 17["17 EVA-2 swap RCU with EVA-1"] 17 -- YES --> 18 17 -- NO --> 19 15 --> 20 </pre>	

APOLLO OPERATIONS HANDBOOK-EMU

SYMPTOM	PROCEDURE	REMARKS
<p>EMU 17</p> <p>EVA-2 loses voice from EVA-1 (see "Additional conditions" below)</p> <p>Additional conditions:</p> <ol style="list-style-type: none"> Dual EVA EVA-2 has comm. with MSFN <p>Possible causes:</p> <ol style="list-style-type: none"> EVA-2 B/C volume control turned too low EVA-2 "B" receiver failed EVA-1 RCU PTT switch turned OFF EVA-2 "B" section triplexer or K-2 relay antenna section failed <p>(Continued on next page)</p>	<p>EVA PROCEDURE</p> <p>1 ● EVA-2 set RCU B/C volume to MAX. Comm. restored</p> <p>2 VOLUME CONTROL WAS TURNED TOO LOW</p> <p>3 Does MSFN have comm. from EVA-1</p> <p>4 ● EVA-2 set mode sel. SW. to "A" ● EVA-1 set mode sel. SW. to "B" EVA-2/EVA-1 comm. all right</p> <p>5 EVA-2 "B" RECEIVER FAILED</p> <p>6 ● EVA-1 ensure that RCU PTT switch is in MAIN position EVA-2/EVA-1 comm. restored</p> <p>7 EVA-1 RCU PTT SW. ACCIDENTALLY SET TO OFF POSITION</p> <p>8 EVA-2 "B" SECTION TRIPLEXER OR K-2 RELAY ANTENNA SECTION FAILED</p> <p>9 ● EVA-1 set RCU PTT switch to MOM position EVA-2/EVA-1 comm. restored</p> <p>10 EVA-1 VOX CIRCUIT OR RCU PTT SWITCH VOX SECTION FAILED</p> <p>POST EVA PROCEDURE</p> <p>11 ● EVA-1 swap RCU with EVA-2 EVA-2/EVA-1 comm. restored</p> <p>12 EVA-1 RCU PTT SWITCH CIRCUIT FAILED</p> <p>To step 13 next page</p>	

CSD-A-789-(2) III
 APOLLO OPERATIONS HANDBOOK-EMU

SYMPTOM	PROCEDURE	REMARKS
<p>Possible causes: (continued)</p> <p>e. EVA-1 VOX circuit or RCU PTT switch VOX section failed</p> <p>f. EVA-1 RCU PTT switch circuit failed</p> <p>g. EVA-1 primary/dual signal processor failed</p> <p>h. EVA-1 VOX/PTT circuit failed</p> <p>i. EVA-1 comm. carrier failed</p> <p>j. EVA-1 suit electrical harness failed</p>	<p>POST-EVA PROCEDURE (Continued)</p> <pre> graph TD 13["13 ● EVA-1 connect to LM umbilical EVA-1/EVA-2 comm. restored"] 14["14 ● EVA-1 reconnect to PLSS ● RCU mode sel. switch to 'B' ● LM set for backup mode EVA-1/MSFN comm. restored"] 15["15 EVA-1 PRIMARY/DUAL SIGNAL PROCESSOR FAILED"] 16["16 EVA-1 VOX/PTT CIRCUIT FAILED"] 17["17 ● EVA-1 swap comm. carrier with EVA-2 EVA-1/MSFN comm. restored"] 18["18 EVA-1 COMM. CARRIER FAILED"] 19["19 ● EVA-1 SUIT ELECTRICAL HARNESS FAILED"] 13 -- YES --> 14 13 -- NO --> 17 14 -- YES --> 15 14 -- NO --> 16 17 -- YES --> 18 17 -- NO --> 19 </pre>	

APOLLO OPERATIONS HANDBOOK-EMU

SYMPTOM	PROCEDURE	REMARKS
<p>EMU 18</p> <p>Loss of voice comm. with EVA-1, EVA-2, or MSFN (two-man EVA) (comm. restoration procedure)</p> <p>Possible causes:</p> <ul style="list-style-type: none"> a. EVCS receiver "A" squelch failure b. LM VHF "A" failure c. Volume control too low d. PTT switch OFF or intermittent e. VOX circuit failure f. EVA-1 XMTR "B", EVA-1 RCVR "C", EVA-2 RCVR "B", or EVA-2 XMTR "C" failed. g. EVA-1 RCVR "B"/RCVR "C" summed output failure h. EVA-1 or EVA-2 total comm. failure 	<p style="text-align: center;">EVA PROCEDURE</p>	<p>① Reception of MSFN is disabled while outer volume is in full DECREASE.</p> <p>② EMU data not available from EVA-1. EVA-1 cannot hear MSFN.</p> <p>③ EMU data not available from EVA-2. EVA-2 cannot hear MSFN.</p>

CSD-A-789-(2) III
 APOLLO OPERATIONS HANDBOOK-EMU

SYMPTOM	PROCEDURE	REMARKS
<p>EMU 19</p> <p>EVA loses voice from LM (see "Additional conditions" below)</p> <p>Additional conditions:</p> <ol style="list-style-type: none"> 1. Single EVA <p>Possible causes:</p> <ol style="list-style-type: none"> a. EVA "A" volume control turned too low b. EVA "A" receiver RF section failed c. R/T relay K-1 failed d. EVA antenna failed e. EVA comm. carrier failed f. Triplexer common port failed g. LM electrical umbilical failed <p>(Continued on next page)</p>	<p style="text-align: center;">EVA PROCEDURE</p> <div style="border: 1px solid black; padding: 5px; margin-bottom: 10px;"> <p>1</p> <p>Does EVA receive voice from MSFN</p> <p style="text-align: right;">YES</p> <p style="text-align: right;">NO</p> </div> <p style="text-align: right;">To step 12 next page</p> <div style="border: 1px solid black; padding: 5px; margin-bottom: 10px;"> <p>2</p> <p>• EVA set RCU "A" volume control to MAX.</p> <p>Comm. restored</p> <p style="text-align: right;">YES</p> <p style="text-align: right;">NO</p> </div> <div style="border: 1px solid black; padding: 5px; margin-bottom: 10px;"> <p>3</p> <p>EVA "A" VOLUME CONTROL TURNED TOO LOW</p> </div> <div style="border: 1px solid black; padding: 5px; margin-bottom: 10px;"> <p>4</p> <p>Does EVA hear sidetone</p> <p style="text-align: right;">YES</p> <p style="text-align: right;">NO</p> </div> <div style="border: 1px solid black; padding: 5px; margin-bottom: 10px;"> <p>5</p> <p>• EVA and LM configure for "B" mode</p> <p>Comm. restored</p> <p style="text-align: right;">YES</p> <p style="text-align: right;">NO</p> </div> <div style="border: 1px solid black; padding: 5px; margin-bottom: 10px;"> <p>6</p> <p>EVA "A" RCVR. RF SECTION, OR R/T RELAY K-1, OR LM FAILED</p> </div> <hr style="border-top: 1px dashed black;"/> <p style="text-align: center;">POST-EVA PROCEDURE</p> <div style="border: 1px solid black; padding: 5px; margin-bottom: 10px;"> <p>7</p> <p>• EVA connect to LM Umbil.</p> <p>Comm. restored</p> <p style="text-align: right;">YES</p> <p style="text-align: right;">NO</p> </div> <div style="border: 1px solid black; padding: 5px; margin-bottom: 10px;"> <p>8</p> <p>• EVA swap OPS with other crewman</p> <p>Comm. restored</p> <p style="text-align: right;">YES</p> <p style="text-align: right;">NO</p> </div> <div style="border: 1px solid black; padding: 5px; margin-bottom: 10px;"> <p>9</p> <p>EVA ANTENNA FAILED</p> </div> <div style="border: 1px solid black; padding: 5px; margin-bottom: 10px;"> <p>10</p> <p>EVA COMM. CARRIER FAILED</p> </div> <div style="border: 1px solid black; padding: 5px;"> <p>11</p> <p>EVA R/T RELAY K-1, K-2, OR TRIPLEXER COMMON PORT FAILED</p> </div> <p style="text-align: center;">To step 15 next page</p>	

APOLLO OPERATIONS HANDBOOK-EMU

SYMPTOM	PROCEDURE	REMARKS
POST-EVA PROCEDURE (Continued)		
<p>Possible causes: (continued)</p> <p>h. EVA RCU "A" volume circuit failed</p> <p>i. LM failed</p> <p>j. EVA "A" receiver RF section failed</p> <p>k. PLSS electrical umbilical failed</p> <p>l. Primary dual comm. regulator failed</p> <p>m. EVA "A" receiver failed</p>	<pre> graph TD 12["12 ● LM crewman transfer to pilot's elect. umbilical Comm. with MSFN all right"] -- YES --> 13["13 LM ELECTRICAL UMBILICAL FAILED"] 12 -- NO --> 14["14 LM CREWMAN COMM. CARRIER FAILED"] 14 --> 15["15 ● EVA connect to other PLSS Comm. restored"] 15 -- YES --> 16["16 ● EVA reconnect to original PLSS, swap RCU with other crewman Comm. restored"] 15 -- NO --> 18["18 LM FAILED"] 16 -- YES --> 17["17 EVA RCU "A" VOLUME CIRCUIT FAILED"] 16 -- NO --> 19["19 Does EVA hear sidetone"] 19 -- YES --> 20["20 EVA "A" RCVR. RF SECTION OR R/T RELAY K-1 FAILED"] 19 -- NO --> 22["22 Did LM receive voice from EVA"] 22 -- YES --> 23["23 EVA "A" RCVR. OR R/T RELAY K-1 FAILED"] 22 -- NO --> 21["21 PRIMARY/DUAL COMM. REGULATOR FAILED"] 21 --> 15 </pre>	

APOLLO OPERATIONS HANDBOOK-EMU

SYMPTOM	PROCEDURE	REMARKS
<p>EMU 20</p> <p>LM loses voice from EVA (see "Additional conditions" below)</p> <p>Additional conditions:</p> <ol style="list-style-type: none"> 1. Single EVA <p>Possible causes:</p> <ol style="list-style-type: none"> a. LM failed b. EVA RCU PTT switch turned OFF c. EVA VOX circuit failed d. EVA "A" mode failed e. EVA comm. carrier failed f. EVA RCU VOX circuit failed <p>(Continued on next page)</p>	<p style="text-align: center;">EVA PROCEDURE</p> <pre> graph TD Start[LM loses voice from EVA] --> Step1{1 Does LM receive voice from MSFN} Step1 -- YES --> Step2{2 Does MSFN have voice from EVA} Step1 -- NO --> Step4{4 LM FAILED} Step2 -- YES --> Step3{3 LM FAILED} Step2 -- NO --> Step5{5 EVA ensure RCU PTT switch in MAIN position Comm. restored} Step5 -- YES --> Step6{6 EVA RCU PTT SWITCH ACCIDENTALLY SET TO OFF} Step5 -- NO --> Step7{7 EVA set RCU to PTT Comm. restored} Step7 -- YES --> Step15{To step 15 next page} Step7 -- NO --> Step8{8 EVA set mode sel. SW. to "B" mode Comm. restored} Step8 -- YES --> Step9{9 EVA "A" MODE FAILED OR LM FAILED CONFIGURE LM FOR "B" MODE} Step8 -- NO --> Step10{10 EVA check comm. using other PLSS/OPS Comm. with LM} Step9 --> Step16{To step 16 next page} Step10 -- YES --> Step16 Step10 -- NO --> Step11{To step 11 next page} </pre> <p style="text-align: center;">POST-EVA PROCEDURE</p>	

APOLLO OPERATIONS HANDBOOK-EMU

SYMPTOM	PROCEDURE	REMARKS
POST-EVA PROCEDURE (Continued)		
Possible causes: (continued) g. EVA RCU mode select "A" wafer failed h. EVA antenna failed i. EVA triplexer common port failed j. Suit electrical harness failed	<div style="border: 1px solid black; padding: 5px; margin-bottom: 5px;"> 11 ● EVA swap comm. carrier Comm. restored </div>	
	YES → <div style="border: 3px double black; padding: 5px; display: inline-block;"> 12 EVA COMM. CARRIER FAILED </div>	
	NO ↓ <div style="border: 1px solid black; padding: 5px; margin-bottom: 5px;"> 13 ● LM OR SUIT ELECTRICAL HARNESS FAILED </div>	
	YES → <div style="border: 1px solid black; padding: 5px; margin-bottom: 5px;"> 14 EVA RCU VOX CIRCUIT FAILED </div>	
	YES → <div style="border: 1px solid black; padding: 5px; margin-bottom: 5px;"> 15 ● Swap RCU ● EVA operates in MAIN Comm. all right </div>	
	NO ↓ <div style="border: 3px double black; padding: 5px; display: inline-block;"> 18 EVA VOX CIRCUIT FAILED </div>	
	YES → <div style="border: 1px solid black; padding: 5px; margin-bottom: 5px;"> 16 ● EVA swap back to original RCU Comm. restored </div>	
	YES → <div style="border: 1px solid black; padding: 5px; margin-bottom: 5px;"> 17 ● EVA swap back to original OPS Comm. all right </div>	
	NO ↓ <div style="border: 1px solid black; padding: 5px; margin-bottom: 5px;"> 19 EVA RCU "A" WAFER MODE SELECTOR FAILED </div>	
	NO ↓ <div style="border: 1px solid black; padding: 5px; margin-bottom: 5px;"> 20 EVA ANTENNA FAILED </div>	
YES → <div style="border: 3px double black; padding: 5px; display: inline-block;"> 21 EVA TRIPLEXER FAILED </div>		

CSD-A-789-(2) III
APOLLO OPERATIONS HANDBOOK - EMU

SYMPTOM	PROCEDURE	REMARKS
EMU 21 ①	EVA PROCEDURE	
<p>GT8168P/GT8268P PGA pressure <3.7 psid and apparently steady (no warning tone)</p> <p>Possible causes:</p> <ol style="list-style-type: none"> a. GT8168F/GT8268P failed b. PLSS O₂ regulator shift/degraded c. EMU leak 	<div style="display: flex; justify-content: space-between;"> <div style="width: 30%;"> <p>1</p> <p>GT8168P/GT8268P PGA pressure >3.1 psid</p> <p>NO</p> </div> <div style="width: 30%;"> <p>2</p> <p>GT8182P/GT8282P PLSS O₂ pressure abnormal</p> <p>NO</p> </div> <div style="width: 30%;"> <p>3</p> <p>High O₂ flow flag "0" (O₂ - "0")</p> <p>NO</p> </div> </div> <div style="display: flex; justify-content: space-between; margin-top: 10px;"> <div style="width: 30%;"> <p>4</p> <p>GT8182P/GT8282P PLSS O₂ pressure abnormal</p> <p>NO</p> </div> <div style="width: 30%;"> <p>5</p> <p>High O₂ flow flag "0" (O₂ - "0") and low PGA pressure flag "0" (PRES - "0")</p> <p>NO</p> </div> <div style="width: 30%;"> <p>6</p> <p>WARNING TONE FAILED</p> </div> </div> <div style="display: flex; justify-content: space-between; margin-top: 10px;"> <div style="width: 30%;"> <p>8</p> <p>PGA pressure gage <3.7 psia</p> <p>NO</p> </div> <div style="width: 30%;"> <p>9</p> <p>ALARM MODULE POWER FAILURE</p> </div> <div style="width: 30%;"> <p>7</p> <p>HIGH O₂ FLOW SENSOR FAILED</p> </div> </div> <div style="display: flex; justify-content: space-between; margin-top: 10px;"> <div style="width: 30%;"> <p>11</p> <p>• Flex arms</p> <p>Does PGA pressure gage respond</p> <p>NO</p> </div> <div style="width: 30%;"> <p>12</p> <p>GT8168P/GT8268P PGA PRESSURE FAILED</p> </div> <div style="width: 30%;"> <p>10</p> <p>EMU LEAK</p> </div> </div> <div style="display: flex; justify-content: space-between; margin-top: 10px;"> <div style="width: 30%;"> <p>14</p> <p>PGA PRESSURE GAGE FAILED</p> </div> <div style="width: 30%;"> <p>15</p> <p>PLSS REGULATOR SHIFT/DEGRADED</p> </div> <div style="width: 30%;"> <p>13</p> <p>• Actuate OPS</p> </div> </div> <div style="display: flex; justify-content: space-between; margin-top: 10px;"> <div style="width: 30%;"> <p>17</p> <p>• Actuate OPS</p> </div> <div style="width: 30%;"> <p>16</p> <p>Go to EMU 2, step 4, page 5-7</p> </div> </div>	<p>①</p> <p>PLSS O₂ pressure regulator regulates the PGA to 3.7 psid minimum if flow is 0.07 to 0.7 lb/hr.</p>

CSD-A-789-(2) III
 APOLLO OPERATIONS HANDBOOK EMU

SYMPTOM	PROCEDURE	REMARKS
<p>EMU 22</p> <div style="border: 1px solid black; padding: 5px; margin-top: 10px;"> <p>① GT8168P/ GT8268P PGA press. >4.0 psid</p> </div> <p>Possible causes:</p> <ul style="list-style-type: none"> a. Regulator fails open or shifts set point b. GT8168P/ GT8268P fails 	<p>EMERGENCY PROCEDURE</p> <div style="display: flex; justify-content: space-around; align-items: center;"> <div style="border: 1px solid black; padding: 5px; width: 20%;"> <p>① High O₂ flow flag "0" (after 5 sec); or GT8182P/ GT8282P PLSS O₂ pressure or PLSS O₂ quantity indicator de- creasing rapidly</p> </div> <div style="text-align: center;"> <p>YES</p> </div> <div style="border: 1px solid black; padding: 5px; width: 20%;"> <p>② ● Actuate OPS</p> </div> <div style="text-align: center;"> <p>→</p> </div> <div style="border: 1px solid black; padding: 5px; width: 20%;"> <p>③ PLSS O₂ PRESS. REGULATOR FAILED OPEN OR SHIFTED SET POINT</p> </div> </div> <hr style="border-top: 1px dashed black;"/> <p>EVA PROCEDURE</p> <div style="display: flex; justify-content: space-around; align-items: center;"> <div style="border: 1px solid black; padding: 5px; width: 20%;"> <p>④ Does PGA press. gage agree with GT8168P/GT8268P PGA press.</p> </div> <div style="text-align: center;"> <p>YES</p> </div> <div style="border: 1px solid black; padding: 5px; width: 20%;"> <p>⑤ SHIFT IN PLSS O₂ REGULATED PRESS.</p> </div> </div> <div style="display: flex; justify-content: space-around; align-items: center; margin-top: 10px;"> <div style="border: 1px solid black; padding: 5px; width: 20%;"> <p>⑥ Reduced mobility or hear relief vlv relieving</p> </div> <div style="text-align: center;"> <p>YES</p> </div> <div style="border: 1px solid black; padding: 5px; width: 20%;"> <p>⑦ PGA PRESS. GAGE FAILED</p> </div> </div> <div style="display: flex; justify-content: space-around; align-items: center; margin-top: 10px;"> <div style="border: 1px solid black; padding: 5px; width: 20%;"> <p>⑧ GT8168P/GT8268P PGA PRESS. FAILED</p> </div> </div>	<p>① PLSS O₂ pressure regulator regulates to 4.0 psid maximum to PGA. PGA pressure relief valve cracks at 5.0 to 5.75 psid.</p> <p>② The PLSS O₂ shutoff valve should be CLOSED if possible. If additional mobility is needed, open purge valve to reduce PGA pressure to >3.4 psid.</p> <p>③ Upon returning to the LM, steps 7 and 8 can be verified by con- necting the blue PLSS gas con- nector to the OPS pressure regulator checkout stowage plate.</p>

CSD-A-789-(2) III
APOLLO OPERATIONS HANDBOOK-EMU

SYMPTOM	PROCEDURE	REMARKS
<p>EMU 23</p> <div style="border: 1px solid black; padding: 5px; margin-bottom: 10px;"> GT8182P/ GT8282P PLSS O₂ pressure abnormal (no warning tone) </div> <p>Possible causes:</p> <ol style="list-style-type: none"> a. GT8182P/ GT8282P failed b. PLSS O₂ pressure sensor failed c. EMU leak d. PLSS O₂ pressure regulator failed open e. High O₂ usage 	<p style="text-align: center;">EVA PROCEDURE</p> <pre> graph TD 1[1: GT8168P/GT8268P PGA pressure >3.7 psid] -- YES --> 2[2: GT8168P/GT8268P PGA pressure >4.0 psid] 1 -- NO --> 4[4: Go to step 21 next page] 2 -- YES --> 3[3: High O2 flow flag "0" (O2 - "0")] 2 -- NO --> 5[5: High O2 flow flag "0" (O2 - "0")] 3 -- YES --> 9[9: PLSS O2 PRESSURE REGULATOR FAILED OPEN] 3 -- NO --> 6[6: HIGH O2 FLOW SENSOR FAILED] 4 --> 7[7: PGA pressure gage >3.7 psia] 5 -- NO --> 4 5 -- YES --> 8[8: Actuate OPS, Close PLSS O2 shutoff vlv] 6 --> 9 7 -- YES --> 4 7 -- NO --> 10[10: GT8168P/GT8268P PGA PRESSURE FAILED] 8 --> 9 9 --> 12[12: WARNING TONE FAILED] 10 --> 11[11: EMU LEAK UP-STREAM OF HIGH O2 FLOW SENSOR] 11 --> 8 11 --> 12 12 --> 9 12 --> 15[15: WARNING TONE FAILED] 13[13: GT8168P/GT8268P PGA pressure >3.1 psid] -- YES --> 14[14: High O2 flow flag "0" (O2 - "0")] 13 -- NO --> 16[16: High O2 flow flag "0" (O2 - "0") and low PGA pressure flag "0" (PRES - "0")] 14 -- YES --> 15 14 -- NO --> 17[17: ALARM MODULE POWER FAILURE] 15 --> 18[18: EMU LEAK] 16 --> 17 16 --> 19[19: Actuate OPS] 17 --> 18 17 --> 20[20: Go to step 5, EMU 2, page 5-7] 18 --> 19 19 --> 20 </pre>	<p>① PLSS O₂ pressure regulator regulates the PGA to 3.85 ± 0.15 psid if the flow is 0.07 to 0.7 lb/hr.</p>

CSD-A-789-(2) III
APOLLO OPERATIONS HANDBOOK - EMU

SYMPTOM	PROCEDURE	REMARKS
EVA PROCEDURE (Continued)		
	<div style="display: flex; justify-content: space-around;"> <div style="border: 1px solid black; padding: 5px; width: 45%;"> <p>21 O₂ quantity indicator agrees with GT8182P/GT8282P PLSS O₂ press.</p> </div> <div style="border: 1px solid black; padding: 5px; width: 45%;"> <p>22 Monitor GT8182P/GT8282P PLSS O₂ press.</p> </div> </div>	
POST-EVA PROCEDURE		
	<div style="display: flex; justify-content: space-between;"> <div style="width: 30%;"> <div style="border: 1px solid black; padding: 5px; margin-bottom: 10px;"> <p>23 ● Recharge PLSS O₂ GT8182P/GT8282P PLSS O₂ press. shows recharge</p> </div> <div style="border: 1px solid black; padding: 5px; margin-bottom: 10px;"> <p>26 GT8182P/GT8282P PLSS O₂ PRESSURE FAILED</p> </div> <div style="border: 1px solid black; padding: 5px; margin-bottom: 10px;"> <p>28 PLSS O₂ QUANTITY INDICATOR FAILED</p> </div> </div> <div style="width: 30%;"> <div style="border: 1px solid black; padding: 5px; margin-bottom: 10px;"> <p>24 ● Open purge valve to LOW High O₂ flow flag "0" (O₂ "0")</p> </div> <div style="border: 1px solid black; padding: 5px; margin-bottom: 10px;"> <p>27 HIGH O₂ FLOW SENSOR FAILED</p> </div> <div style="border: 1px solid black; padding: 5px; margin-bottom: 10px;"> <p>29 Go to step 5, EMU 2, page 5-7</p> </div> <div style="border: 1px solid black; padding: 5px; margin-bottom: 10px;"> <p>30 PLSS O₂ PRESSURE REDUCER FAILED</p> </div> <div style="border: 1px solid black; padding: 5px; margin-bottom: 10px;"> <p>31 LEAK BETWEEN PLSS O₂ SHUTOFF VALVE AND HIGH O₂ FLOW SENSOR</p> </div> </div> <div style="width: 30%;"> <div style="border: 1px solid black; padding: 5px; margin-bottom: 10px;"> <p>25 ● PLSS O₂ shutoff valve - OFF ● Recharge PLSS O₂ GT8182P/GT8282P PLSS O₂ press. shows recharge</p> </div> <div style="border: 1px solid black; padding: 5px; margin-bottom: 10px;"> <p>GT8182P/GT8282P PLSS O₂ pressure stable after 20 min</p> </div> <div style="border: 1px solid black; padding: 5px;"> <p>32 LEAK UPSTREAM OF PLSS O₂ SHUTOFF VLV</p> </div> </div> </div>	

CSD-A-789-(2) III
 APOLLO OPERATIONS HANDBOOK - EMU

SYMPTOM	PROCEDURE	REMARKS
<p>EMU 24</p> <p>GT8110P/ GT8210P feedwater pressure <1.2 psia (no warning tone) while using primary feedwater</p> <p>Possible causes:</p> <ol style="list-style-type: none"> a. GT8110P/ GT8210P failed b. Sublimator breakthrough c. H₂O separ- ator blocked d. Depleted pri- mary feed- water reser- voir e. Blockage at primary-feed- water bladder outlet f. Feedwater pressure Xducer failed g. Primary H₂O shutoff and relief valve closed 	<p>EVA PROCEDURE</p> <pre> graph TD Start[1] --> YES Step2[2] Start --> NO Step3[3] Step2 --> YES Step5[5] Step2 --> NO Step4[4] Step4 --> YES Step5 Step4 --> NO Step6[6] Step5 --> Step7[7] Step6 --> Step7 Step7 --> Step9[9] Step9 --> YES Step8[8] Step9 --> NO Step12[12] Step8 --> Step11[11] Step12 --> Step11 Step11 --> YES Step10[10] Step11 --> NO Step13[13] Step13 --> Step14[14] </pre>	
	<p>1 GT8170T/GT8270T O₂ temp >50° F and rising</p> <p>2 GT8154T/GT8254T LCG H₂O temp >50° F and rising GT8196T/GT8296T LCG H₂O ΔT <5° F and dropping (H₂O diverter in MAX. COOLING)</p> <p>3 GT8110P/ GT8210P FEEDWATER PRESSURE FAILED</p> <p>4 Low feedwater pressure flag "A" (H₂O - "A")</p> <p>5 WARNING TONE FAILED</p> <p>6 LOW FEEDWATER PRESSURE SWITCH FAILED</p> <p>7 Go to step 6, EMU 4, page 5-12</p> <p>8 WARNING TONE FAILED</p> <p>9 Low feedwater press. flag "A" (H₂O - "A")</p> <p>10 Go to step 9, EMU 4, page 5-12</p> <p>11 Primary H₂O shutoff and relief valve open</p> <p>12 LOW FEEDWATER PRESSURE SWITCH FAILED</p> <p>13 PRIMARY H₂O SHUTOFF AND RELIEF VALVE CLOSED</p> <p>14 ● H₂O diverter valve - MIN. ● Primary H₂O shutoff and relief valve - OPEN (Wait 1/2 min or until flag clears before changing diverter valve position)</p>	

CSD-A-789-(2) III
APOLLO OPERATIONS HANDBOOK - EMU

SYMPTOM	PROCEDURE	REMARKS
<p>EMU 25</p> <p>GT8110P/GT8210P feedwater press. <1.2 psia (no warning tone) while using auxiliary feedwater</p> <p>Possible causes:</p> <ol style="list-style-type: none"> a. GT8110P/GT8210P failed b. Sublimator breakthrough c. H₂O separator blocked d. Both feedwater reservoirs depleted e. Blockage between bladder and press. xducer f. Feedwater pressure xducer failed g. H₂O shutoff and relief valves closed (either or both) 	<p>EVA PROCEDURE</p> <pre> graph TD S1["1 GT8170T/GT8270T O2 temp >50° F and rising"] S2["2 GT8154T/GT8254T LCG H2O temp 50° F and rising GT8196T/GT8296T LCG H2O ΔT <5° F and dropping (H2O diverter in MAX. COOL NG)"] S3["3 GT8110P/GT8210P FEEDWATER PRESS. FAILED"] S4["4 Low feedwater pressure flag 'A' (H2O - 'A')"] S5["5 WARNING TONE FAILED"] S6["6 Go to step 12, EMU 5, page 5-15"] S7["7 LOW FEEDWATER PRESS. SWITCH FAILED"] S8["8 Go to step 6, EMU 4, page 5-12"] S9["9 If additional cooling is required, activate BSLSS"] S10["10 WARNING TONE FAILED"] S11["11 Low feedwater press. flag 'A' (H2O - 'A')"] S12["12 Auxiliary H2O shutoff and relief valve open"] S13["13 Primary H2O shutoff and relief valve open"] S14["14 LOW FEEDWATER PRESSURE SWITCH FAILED"] S15["15 AUXILIARY H2O SHUTOFF AND RELIEF VALVE CLOSED"] S16["16 PRIMARY H2O SHUTOFF AND RELIEF VALVE CLOSED"] S17["17 H2O diverter valve - MIN. H2O shutoff and relief valves - OPEN (Wait 1/4 min or until flag clears before changing diverter valve position)"] S1 -- YES --> S2 S1 -- NO --> S3 S2 -- YES --> S5 S2 -- NO --> S4 S3 --> S6 S4 -- YES --> S5 S4 -- NO --> S7 S5 --> S11 S7 --> S8 S11 -- YES --> S10 S11 -- NO --> S14 S10 --> S9 S9 -- YES --> S12 S9 -- NO --> S1 S12 --> S15 S13 -- YES --> S12 S13 -- NO --> S16 S14 --> S13 S15 --> S17 S16 --> S17 </pre>	<p>① Actuation of the OPS and opening of the purge valve to HIGH flow may also be used if BSLSS is not carried. If PLSS O₂ valve remains open during purge mode, POS consumables may be depleted.</p> <p>② Sublimator restart may be attempted at this point if desired (procedure for restart is given in step 7, EMU 5, on page 5-14).</p>

CSD-A-789-(2) III
APOLLO OPERATIONS HANDBOOK-EMU

SYMPTOM	PROCEDURE	REMARKS
<p>EMU 26</p> <div style="border: 1px solid black; padding: 5px; margin-top: 10px;"> GT8154T/ GT8254T LCG H₂O temperature >50° F (diverter valve in MAX; and no warning tone) </div> <p>Possible causes:</p> <ol style="list-style-type: none"> a. GT8154T/ GT8254T/ failed b. H₂O shut- off and re- lief valve closed c. Sublimator breakthrough d. H₂O separa- tor blocked e. Depleted feedwater reservoir f. Blockage between feedwater bladder and sublimator 	<p>EVA PROCEDURE</p> <pre> graph TD S1["1 GT8196T/ GT8296T LCG H2O AT <5° F and GT8170T/ GT8270T O2 temperature >50° F"] S2["2 GT8110P/ GT8210P feed- water press. <1.2 psia"] S3["3 FEEDWATER PRESSURE SENSOR FAILED"] S4["4 Low feed- water pressure flag 'A'"] S5["5 GT8154T/ GT8254T LCG H2O TEM- PERATURE FAILED"] S6["6 WARNING TONE FAILED"] S7["7 Go to step 1, EMU 5, page 5-14"] S8["8 Is EMU oper- ating on auxiliary feedwater"] S9["9 LOW FEED- WATER PRESS. SWITCH FAILED"] S10["10 Go to step 1, EMU 4, page 5-12"] S1 -- YES --> S2 S1 -- NO --> S5 S2 -- YES --> S4 S2 -- NO --> S3 S3 --> S6 S4 -- YES --> S6 S4 -- NO --> S9 S5 --> S7 S6 --> S8 S7 --> S8 S8 -- YES --> S7 S8 -- NO --> S10 </pre>	

CSD-A-789-(2) III
 APOLLO OPERATIONS HANDBOOK EMU

SYMPTOM	PROCEDURE	REMARKS
	<p>POST-EVA PROCEDURE</p> <pre> graph TD 9[9 • Replace battery (from other PLSS)] --> 10[10 GT141V/GT8241V PLSS battery voltage >16.0 V dc] 10 -- YES --> 11[11 DEGRADED BATTERY] 10 -- NO --> 12[12 GT8141V/GT8241V PLSS BATTERY VOLTAGE FAILED] </pre>	

CSD-A-789-(2) III
 APOLLO OPERATIONS HANDBOOK-EMU

SYMPTOM	PROCEDURE	REMARKS
<p>EMU 31</p> <div style="border: 1px solid black; padding: 5px; margin-top: 10px;"> GT8170T/ GT8270T O₂ temperature <38° F (no warning tone) </div> <p>Possible causes:</p> <ol style="list-style-type: none"> a. GT8170T/ GT8270T failed b. Fan failed or degraded c. High PGA pressure drop d. Flow restriction in vent loop 	<p>EMERGENCY PROCEDURE</p> <div style="display: flex; justify-content: space-around; align-items: flex-start;"> <div style="border: 1px solid black; padding: 5px; width: 20%;"> <p>1 GT8140C/ GT8240C PLSS battery current >3.0 A or <2.3 A</p> </div> <div style="border: 1px solid black; padding: 5px; width: 20%;"> <p>2 Low vent flow flag "p" (VENT "p")</p> </div> <div style="border: 1px solid black; padding: 5px; width: 20%;"> <p>3 WARNING TONE FAILED</p> </div> </div> <p>NO</p> <div style="display: flex; justify-content: space-around; align-items: flex-start;"> <div style="border: 1px solid black; padding: 5px; width: 20%;"> <p>4 FAN DEGRADED</p> </div> <div style="border: 1px solid black; padding: 5px; width: 20%;"> <p>5 ● Fan off >5 sec VENT "p" and warning tone</p> </div> <div style="border: 1px solid black; padding: 5px; width: 20%;"> <p>6 ● Actuate OPS ● Open purge valve to LOW</p> </div> </div> <p>NO</p> <div style="display: flex; justify-content: space-around; align-items: flex-start;"> <div style="border: 1px solid black; padding: 5px; width: 20%;"> <p>7 LOW VENT FLOW SENSOR FAILED</p> </div> <div style="border: 1px solid black; padding: 5px; width: 20%;"> <p>8 FAN FAILED</p> </div> </div> <hr style="border-top: 1px dashed black;"/> <p>EVA PROCEDURE</p> <div style="display: flex; justify-content: space-around; align-items: flex-start;"> <div style="border: 1px solid black; padding: 5px; width: 20%;"> <p>9 GT8141V/ GT8241V PLSS battery voltage <16.0 V dc</p> </div> <div style="border: 1px solid black; padding: 5px; width: 20%;"> <p>10 ● Fan off >5 sec VENT "p" and warning tone</p> </div> <div style="border: 1px solid black; padding: 5px; width: 20%;"> <p>11 FAILING BATTERY CAUSED FAN DEGRADATION</p> </div> </div> <p>NO</p> <div style="display: flex; justify-content: space-around; align-items: flex-start;"> <div style="border: 1px solid black; padding: 5px; width: 20%;"> <p>12 GT8170T/ GT8270T O₂ TEMPERATURE FAILED, OR HIGH PGA ΔP, OR FLOW RESTRICTION IN VENT LOOP</p> </div> <div style="border: 1px solid black; padding: 5px; width: 20%;"> <p>13 LOW VENT FLOW SENSOR FAILED AND DEGRADED BATTERY CAUSED FAN FAILURE</p> </div> <div style="border: 1px solid black; padding: 5px; width: 20%;"> <p>14 ● Actuate OPS ● Open purge valve to LOW ● Activate BSLSS</p> </div> </div>	<p style="text-align: center;">①</p> <p>Actuation of the OPS and opening of the purge valve to HIGH flow may also be used if BSLSS is not carried. If PLSS O₂ valve remains open during purge mode, POS consumables may be depleted.</p>

CSD-A-789-(2) III
APOLLO OPERATIONS HANDBOOK - EMU

SYMPTOM	PROCEDURE	REMARKS
<p>EMU 32:</p> <div style="border: 1px solid black; padding: 5px; margin-bottom: 10px;"> GT817OT/ GT827OT' O₂ temp >50° F and rising (No warning tone) </div> <p>Possible causes:</p> <ol style="list-style-type: none"> a. GT817OT/ GT827OT failed b. Sublimator breakthrough c. H₂O separator blocked d. Depleted feedwater reservoir e. Blockage be- tween feed- water bladder and sublimator' f. H₂O shutoff and relief valve closed 	<p>EVA PROCEDURE</p> <div style="display: flex; justify-content: space-around; margin-bottom: 10px;"> <div style="border: 1px solid black; padding: 5px; width: 20%;"> 1 GT8110P/ GT8210P feedwater pressure <1.2 psia </div> <div style="border: 1px solid black; padding: 5px; width: 20%;"> 2 LOW feedwater pressure flag "A" (H₂O - "A") </div> <div style="border: 1px solid black; padding: 5px; width: 20%;"> 3 WARNING TONE FAILED </div> </div> <p>NO</p> <div style="border: 1px solid black; padding: 5px; width: 20%; margin-bottom: 10px;"> 5 LOW FEEDWATER PRESS. SWITCH FAILED </div> <p>NO</p> <div style="display: flex; justify-content: space-around; margin-bottom: 10px;"> <div style="border: 1px solid black; padding: 5px; width: 20%;"> 4 GT8154T/ GT8254T LCG H₂O temp >50° F and GT8196T/ GT8296T LCG H₂O ΔT <5° F (H₂O diverter in MAX COOLING) </div> <div style="border: 1px solid black; padding: 5px; width: 20%;"> 7 LOW feedwater pressure flag "A" (H₂O - "A") </div> <div style="border: 1px solid black; padding: 5px; width: 20%;"> 8 GT8110P/ GT8210P FEEDWATER PRESSURE FAILED AND WARNING TONE FAILED </div> </div> <p>NO</p> <div style="display: flex; justify-content: space-around; margin-bottom: 10px;"> <div style="border: 1px solid black; padding: 5px; width: 20%;"> 6 GT817OT/ GT827OT O₂ TEMP FAILED </div> <div style="border: 1px solid black; padding: 5px; width: 20%;"> 9 FEEDWATER PRESSURE SENSOR FAILED </div> </div> <p>NO</p> <div style="display: flex; justify-content: space-around; margin-bottom: 10px;"> <div style="border: 1px solid black; padding: 5px; width: 40%;"> 10 Is EMU oper- ating on auxiliary feedwater </div> <div style="border: 1px solid black; padding: 5px; width: 20%;"> 11 Go to step 1, EMU 5, page 5-14 </div> </div> <p>NO</p> <div style="border: 1px solid black; padding: 5px; width: 20%;"> 12 Go to step 1, EMU 4, page 5-12 </div>	