

Apollo Lunar Surface Experiments Package

ALSEP Familiarization Course Handout

For Training Purposes Only

1 May 1969

Contract NAS9-5829

BSR 2264-B

Prepared for
MANNED SPACECRAFT CENTER
HOUSTON, TEXAS

by



**Aerospace
Systems Division**

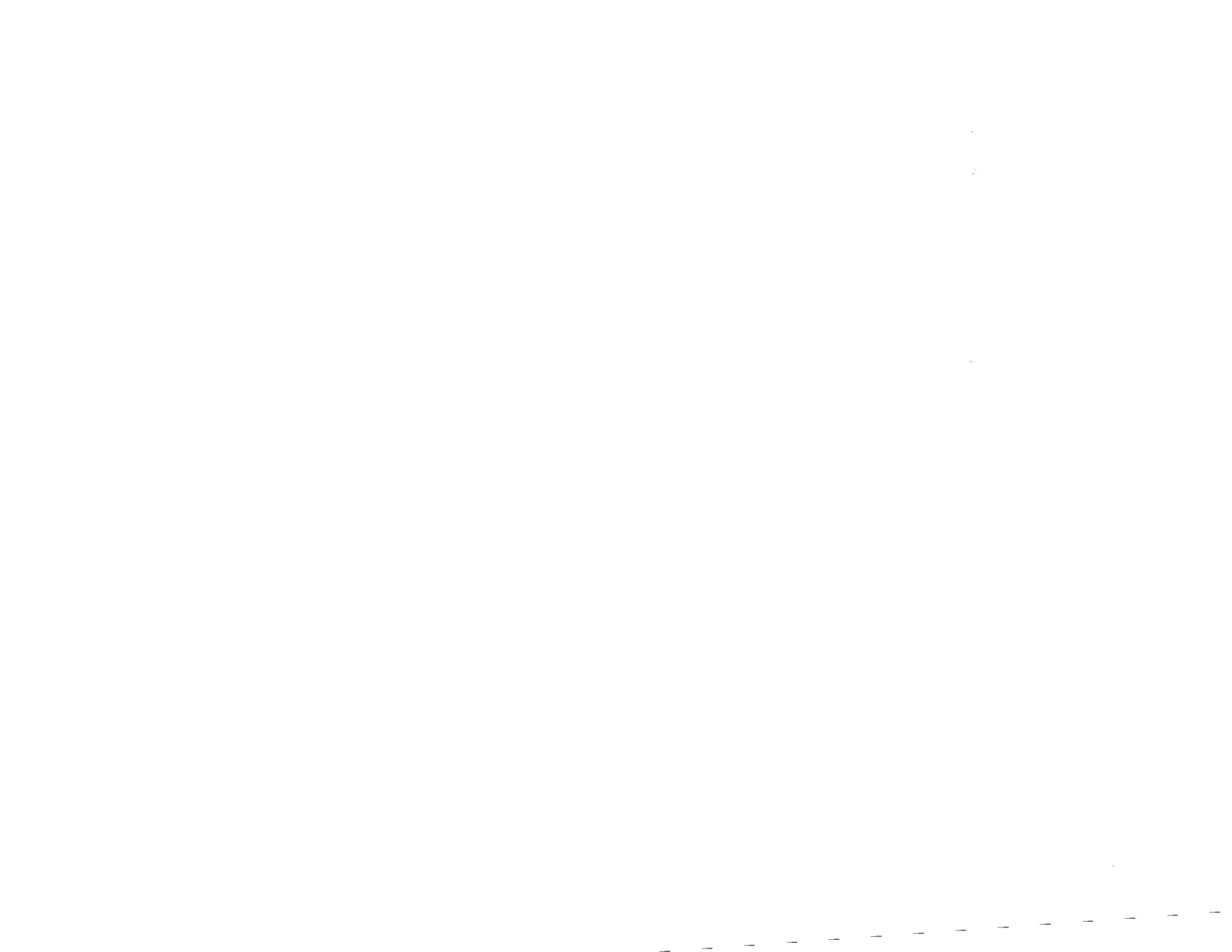
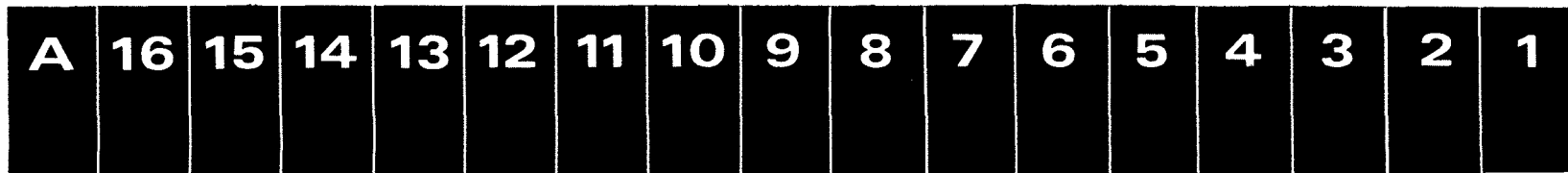

TABLE OF CONTENTS

<p>LESSON</p> <p>1. BACKGROUND & OBJECTIVES</p> <p style="padding-left: 20px;">SYSTEM OBJECTIVES 1.1</p> <p style="padding-left: 20px;">EXPERIMENT OBJECTIVES 1.7</p> <p>2. SYSTEM REQUIREMENTS & CONSTRAINTS</p> <p style="padding-left: 20px;">INSTALLATION & PRELAUNCH 2.1</p> <p style="padding-left: 20px;">LAUNCH, FLIGHT & LANDING 2.10</p> <p style="padding-left: 20px;">LUNAR SURFACE 2.11</p> <p style="padding-left: 20px;">DATA TRANSMISSION & RECEPTION 2.17</p> <p style="padding-left: 20px;">GENERAL DESIGN CRITERIA 2.24</p> <p>3. SYSTEM LEVEL DESCRIPTION</p> <p style="padding-left: 20px;">SYSTEM OVERVIEW 3.1</p> <p style="padding-left: 20px;">SUPPORTING SUBSYSTEMS 3.6</p> <p style="padding-left: 20px;">EXPERIMENT SUBSYSTEMS 3.26</p> <p style="padding-left: 20px;">WEIGHT, POWER, & DATA SUMMARY 3.48</p> <p>4. ALSEP OPERATIONS</p> <p style="padding-left: 20px;">PRELAUNCH 4.1</p> <p style="padding-left: 20px;">LUNAR SURFACE 4.7</p> <p style="padding-left: 20px;">LUNAR MISSION PHASE 4.27</p> <p style="padding-left: 20px;">FORTY-FIVE DAY PHASE 4.33</p> <p style="padding-left: 20px;">ONE-YEAR PHASE 4.34</p> <p>5. STRUCTURE/THERMAL SUBSYSTEM</p> <p style="padding-left: 20px;">COMPONENTS & FUNCTION 5.1</p> <p style="padding-left: 20px;">DEPLOYMENT 5.12</p> <p style="padding-left: 20px;">COMMANDS & DATA 5.15</p> <p>6. ELECTRICAL POWER SUBSYSTEM</p> <p style="padding-left: 20px;">RTG 6.1</p> <p style="padding-left: 20px;">CREW ACTIVITIES 6.7</p> <p style="padding-left: 20px;">PCU 6.9</p> <p style="padding-left: 20px;">COMMANDS & TM DATA 6.17</p> <p>7. DATA SUBSYSTEM</p> <p style="padding-left: 20px;">GENERAL 7.1</p> <p style="padding-left: 20px;">UPLINK COMPONENTS 7.9</p> <p style="padding-left: 20px;">DOWNLINK COMPONENTS 7.45</p> <p style="padding-left: 20px;">MISCELLANEOUS 7.94</p> <p>8. PASSIVE SEISMIC EXPERIMENT SUBSYSTEM</p> <p style="padding-left: 20px;">COMPONENTS & FUNCTION 8.1</p> <p style="padding-left: 20px;">DEPLOYMENT 8.11</p> <p style="padding-left: 20px;">COMMANDS & DATA 8.14</p>	<p>9. ACTIVE SEISMIC EXPERIMENT SUBSYSTEM</p> <p style="padding-left: 20px;">COMPONENTS & FUNCTION 9.1</p> <p style="padding-left: 20px;">DEPLOYMENT 9.18</p> <p style="padding-left: 20px;">COMMANDS & DATA 9.21</p> <p>10. LUNAR SURFACE MAGNETOMETER SUBSYSTEM</p> <p style="padding-left: 20px;">COMPONENTS & FUNCTION 10.1</p> <p style="padding-left: 20px;">COMMANDS & DATA 10.33</p> <p style="padding-left: 20px;">DEPLOYMENT 10.35</p> <p>11. SOLAR WIND SPECTROMETER SUBSYSTEM</p> <p style="padding-left: 20px;">COMPONENTS & FUNCTION 11.1</p> <p style="padding-left: 20px;">DEPLOYMENT 11.12</p> <p style="padding-left: 20px;">COMMANDS & DATA 11.16</p> <p>12. SUPRATHERMAL ION DETECTOR EXPERIMENT SUBSYSTEM</p> <p style="padding-left: 20px;">COMPONENTS & FUNCTION 12.1</p> <p style="padding-left: 20px;">DEPLOYMENT 12.20</p> <p style="padding-left: 20px;">COMMANDS & DATA 12.23</p> <p>13. HEAT FLOW EXPERIMENT SUBSYSTEM</p> <p style="padding-left: 20px;">COMPONENTS & FUNCTION 13.1</p> <p style="padding-left: 20px;">COMMANDS & DATA 13.6</p> <p style="padding-left: 20px;">DEPLOYMENT 13.19</p> <p style="padding-left: 20px;">ALSD 13.25</p> <p>14. CHARGED - PARTICLE LUNAR ENVIRONMENT EXPERIMENT SUBSYSTEM</p> <p style="padding-left: 20px;">COMPONENTS & FUNCTION 14.1</p> <p style="padding-left: 20px;">DEPLOYMENT 14.10</p> <p style="padding-left: 20px;">COMMANDS & DATA 14.13</p> <p>15. COLD CATHODE GAUGE EXPERIMENT</p> <p style="padding-left: 20px;">COMPONENTS & FUNCTION 15.1</p> <p style="padding-left: 20px;">DEPLOYMENT 15.10</p> <p style="padding-left: 20px;">COMMANDS & DATA 15.11</p> <p>16. MSFN/MCC OPERATIONS</p> <p style="padding-left: 20px;">CMD & TM PROCESSING 16.1</p> <p style="padding-left: 20px;">SOFTWARE & DISPLAYS 16.4</p> <p style="padding-left: 20px;">SPECIAL REQUIREMENTS 16.7</p> <p style="padding-left: 20px;">DETAILED MONITORING 16.9</p> <p>ABBREVIATIONS A</p>
--	--





APOLLO LUNAR SURFACE EXPERIMENTS PACKAGE

- SYSTEM OBJECTIVES
 - BACKGROUND
 - EXPERIMENT SELECTION
 - ORGANIZATION

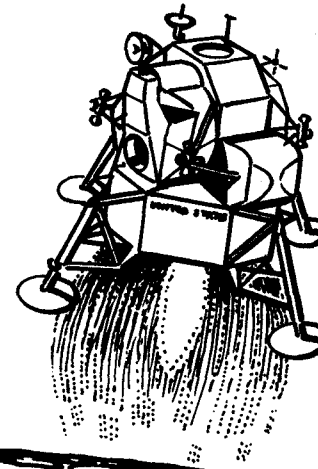

- A PACKAGE OF SCIENTIFIC INSTRUMENTS AND SUPPORTING SUBSYSTEMS FOR USE ON THE LUNAR SURFACE
- CARRIED ON APOLLO, DEPLOYED BY ASTRONAUT
- ONE YEAR CONTINUOUS OPERATION (2 YEAR MAXIMUM)

OCT 67 5178.1.1

ALSEP SYSTEM OBJECTIVES

DETERMINE
LUNAR
CHARACTERISTICS

- INTERNAL STRUCTURE & COMPOSITION
- STATE OF INTERIOR
- COMPOSITION OF ATMOSPHERE
- GENESIS OF SURFACE FEATURES

THIS LUNAR INFORMATION WILL PROVIDE NEW INSIGHTS
INTO THE GEOLOGY & GEOPHYSICS OF THE EARTH.

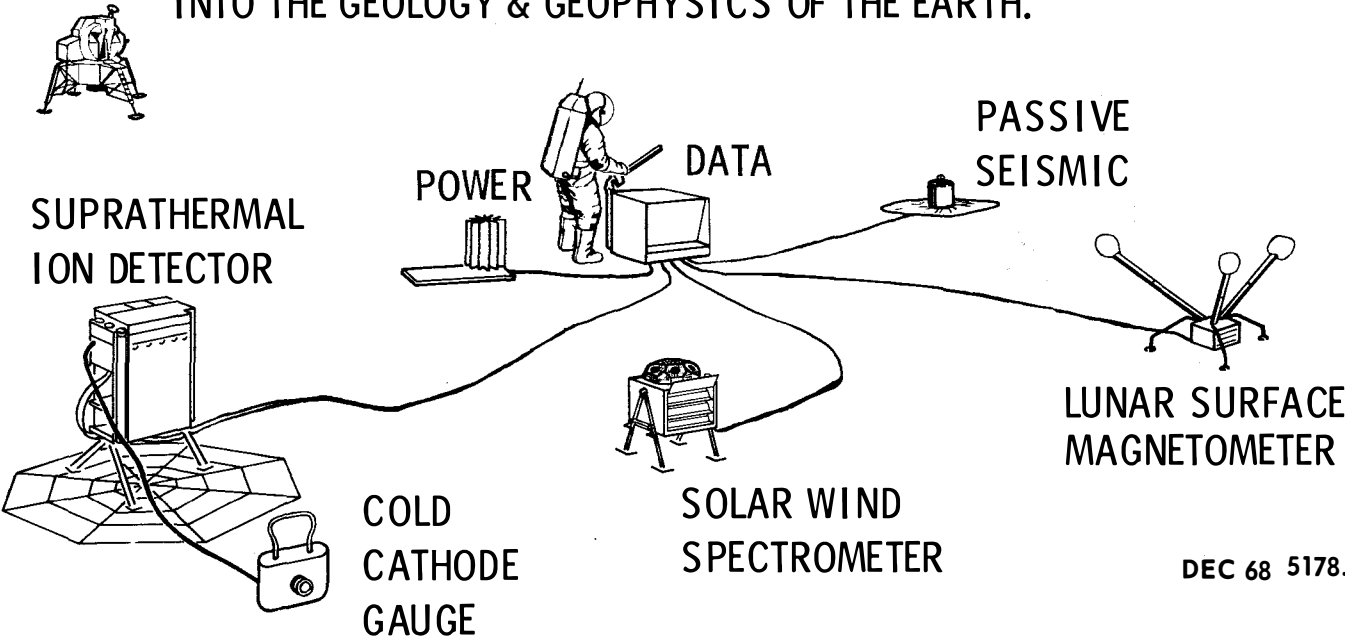

ALSEP EXPERIMENTS

NASA NO.	EXPERIMENT	PRINCIPAL INVESTIGATOR
S031	PASSIVE SEISMIC	DR. G. V. LATHAM, COLUMBIA
S033	ACTIVE SEISMIC	DR. R. L. KOVACH, STANFORD
S034	MAGNETOMETER	DR. C. P. SONNETT, ARC
S035	SOLAR WIND	DR. C. W. SNYDER, JPL
S036	SUPRATHERMAL ION	DR. J. W. FREEMAN, RICE
S037	HEAT FLOW	DR. M. G. LANGSETH, COLUMBIA
S038	CHARGED - PARTICLE	DR. B. J. O'BRIEN, RICE
S058	COLD CATHODE GAUGE*	DR. F. S. JOHNSON, SCAS
S059	LUNAR FIELD GEOLOGY**	DR. E. M. SHOEMAKER, USGS

* INCLUDED IN SUPRATHERMAL ION ON CERTAIN FLIGHTS

** EQUIP PARTIALLY CARRIED BY ALSEP

MAY 69 5178.1.3

ALSEP HARDWARE DEFINITIONS

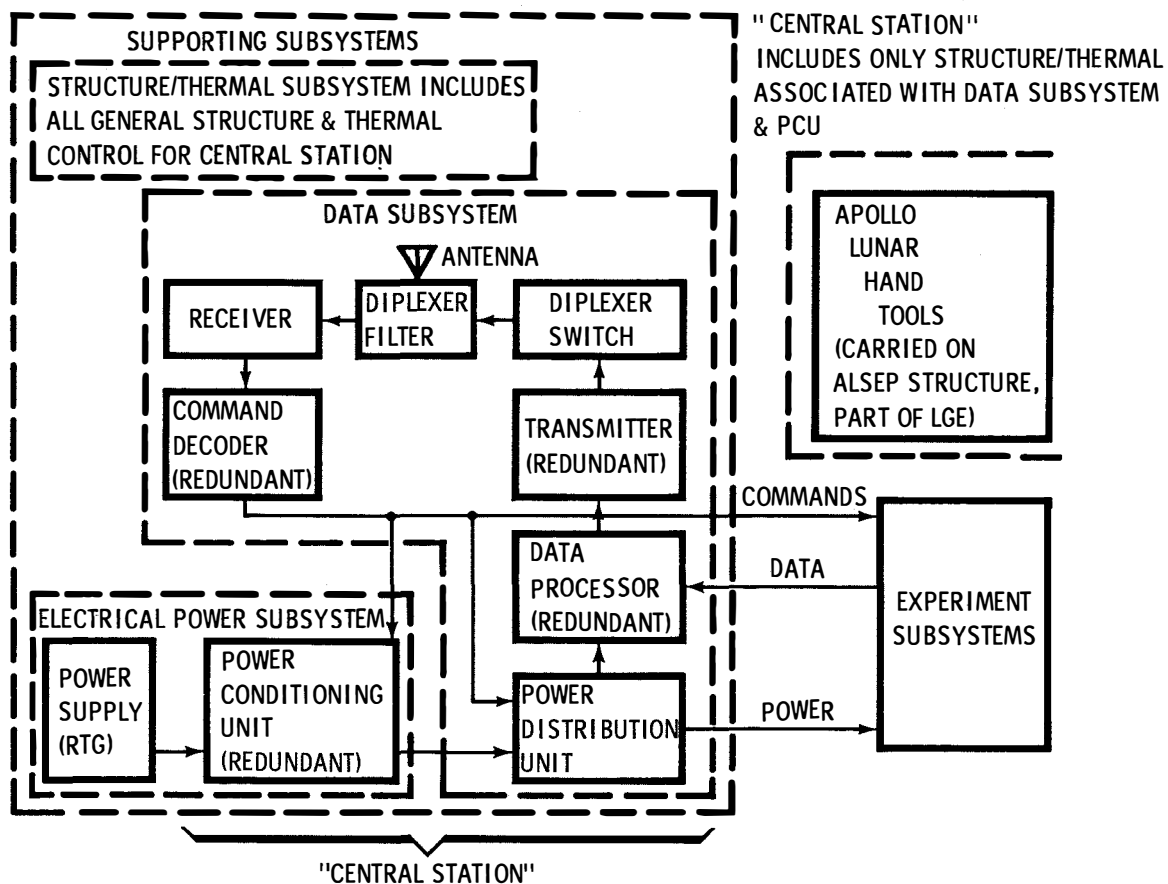

MAY 69 5178.1.4

ALSEP FLIGHT ASSIGNMENTS

- TO BE CARRIED ON EARLY APOLLO FLIGHTS
- THREE FLIGHT ARTICLES
- ALL 7 EXPERIMENTS CANNOT BE CARRIED SIMULTANEOUSLY

EXPERIMENT	ABBR	ALSEP NUMBER		
		1	3	4
PASSIVE SEISMIC	PSE	X	X	X
ACTIVE SEISMIC	ASE			X
MAGNETOMETER	LSM	X		
SOLAR WIND	SWS	X		
SUPRATHERMAL ION	SIDE	X		X
HEAT FLOW	HFE		X	
CHARGED-PARTICLE	C PLEE		X	X
COLD CATHODE GAUGE*	CCIG		X	

* INCLUDED IN SUPRATHERMAL ION ON OTHER FLIGHTS
 ALL CONFIGURATIONS HAVE SIMILAR POWER AND
 DATA SUBSYSTEMS

ALSEP ORGANIZATION

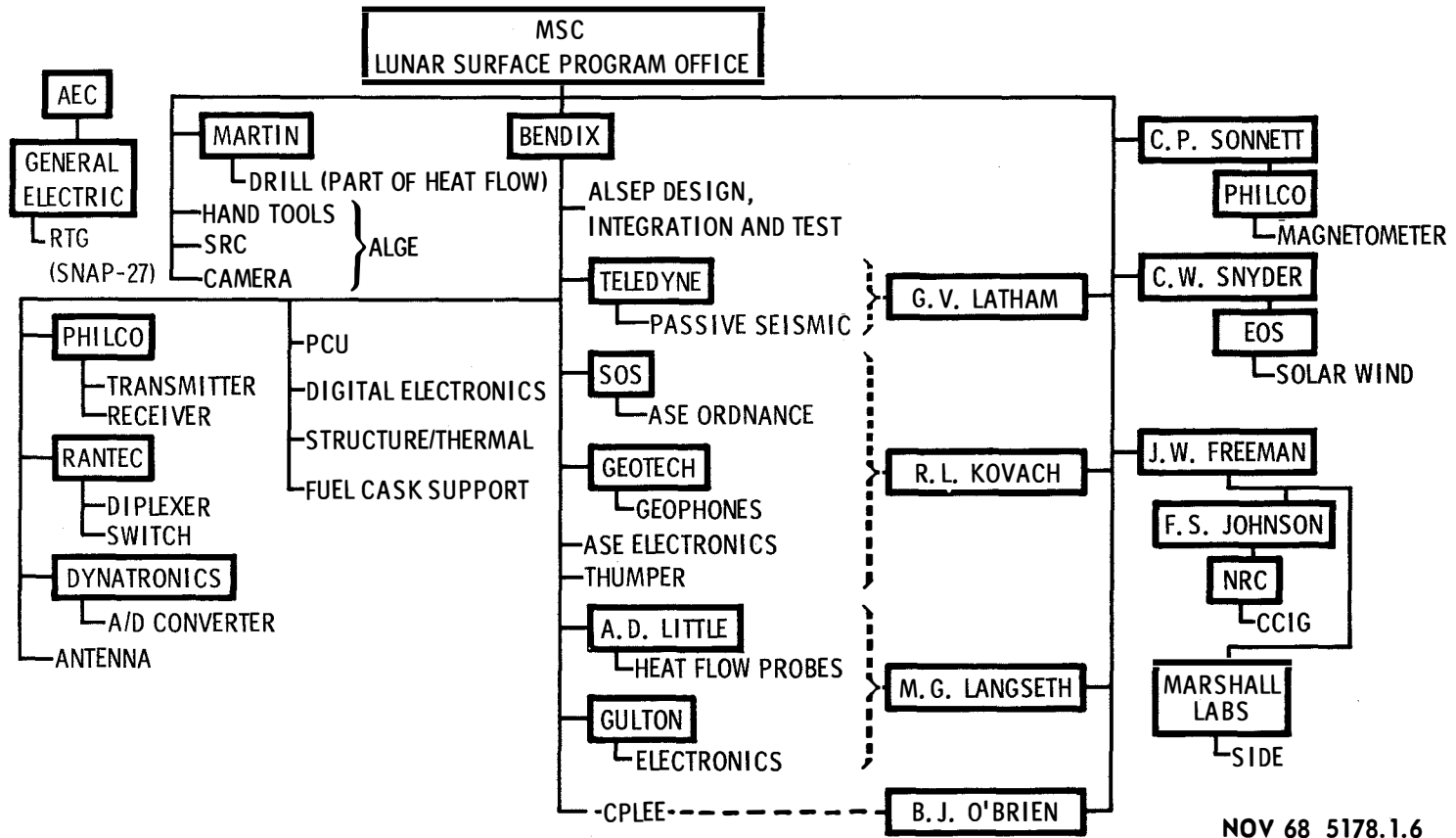

LUNAR FIELD GEOLOGY

NASA No. SO59

OBJECTIVE: PHYSICAL PROPERTIES; e. g. , DENSITY, CHEMICAL COMPOSITION, DIELECTRIC CONSTANT, ELECTRICAL CONDUCTIVITY, MAGNETIC SUSCEPTIBILITY, ALBEDO, COSMIC RAY HISTORY.

MEASUREMENT: IN SITU EXAMINATION, RETURN SAMPLES

EQUIPMENT: ASCENT STAGE - SAMPLE RETURN CONTAINERS, CAMERA

DESCENT STAGE - APOLLO LUNAR HAND TOOLS (ALHT)

CARRIED ON ALSEP BUT NOT A PART
OF THE ALSEP MISSION

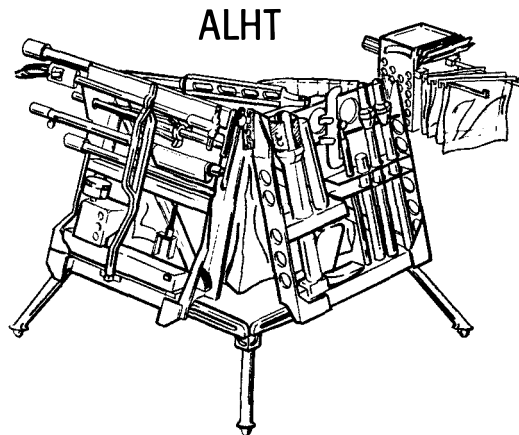

TOOL CARRIER
SAMPLING HAMMER
BRUSH
SCOOP
WEIGHING SCALE
SAMPLE COLLECTION BAGS
ETC.

APR 69 5178.1.7

ALSEP EXPERIMENT OBJECTIVES

EXPERIMENTS	OBJECTIVES			
	INTERNAL STRUCTURE & COMPOSITION	STATE OF INTERIOR	COMPOSITION OF ATMOSPHERE	GENESIS OF SURFACE FEATURES
PASSIVE SEISMIC	X	X		X
ACTIVE SEISMIC	X			X
MAGNETOMETER	X	X		X
SOLAR WIND	X		X	X
SUPRATHERMAL ION		X	X	X
HEAT FLOW	X	X		X
CHARGED - PARTICLE			X	
COLD CATHODE ION GAUGE			X	

APR 69 5178.1.8

PASSIVE SEISMIC

NASA No. S031

OBJECTIVE: INTERNAL SEISMIC ENERGY & STRAIN REGIME, OVERALL PHYSICAL PROPERTIES (CORE/MANTLE, etc.), DISTANCE & DIRECTION TO EPICENTERS FOR CORRELATION WITH SURFACE FEATURES.

MEASUREMENT: NATURAL SEISMIC WAVE VELOCITY, FREQUENCY, AMPLITUDE & ATTENUATION; FREE OSCILLATIONS & TIDAL DEFORMATIONS

EQUIPMENT: ONE VERTICAL SHORT - PERIOD ELEMENT, THREE ORTHOGONAL LONG-PERIOD ELEMENTS

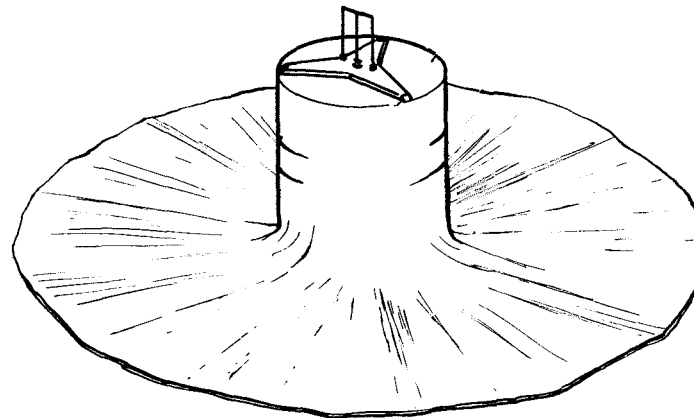

ACTIVE SEISMIC

NASA No. S033

OBJECTIVE: PHYSICAL PROPERTIES TO SHALLOW DEPTHS,
FORMATION PROCESSES

MEASUREMENT: ARTIFICIAL SEISMIC WAVE VELOCITY,
FREQUENCY, & ATTENUATION

EQUIPMENT: ENERGY SOURCES (THUMPER & GRENADES),
DETECTION EQUIPMENT (GEOPHONES & AMPLIFIERS)

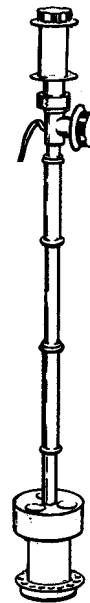
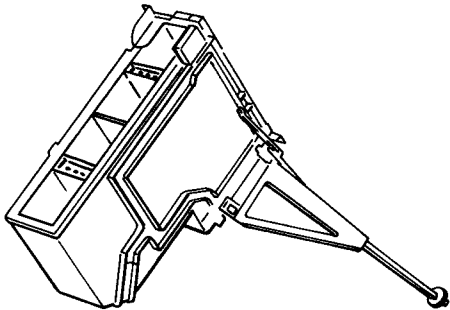

APR 69 5178.1.10

LUNAR SURFACE MAGNETOMETER

NASA No. S034

OBJECTIVE: MOON'S FIELD - SOLAR WIND, GROSS ELECTRICAL DIFFUSIVITY,
EXISTENCE OF MOLTEN CORE, EARTH'S TURBULENT WAKE, LOCAL MAGNETIC
ANOMALIES

MEASUREMENT: MAGNETIC FIELD VECTOR & ITS VARIATION WITH TIME; FIELD
GRADIENT

EQUIPMENT: THREE
FLUX-GATE SENSORS
ON ORTHOGONAL
3 - FT BOOMS

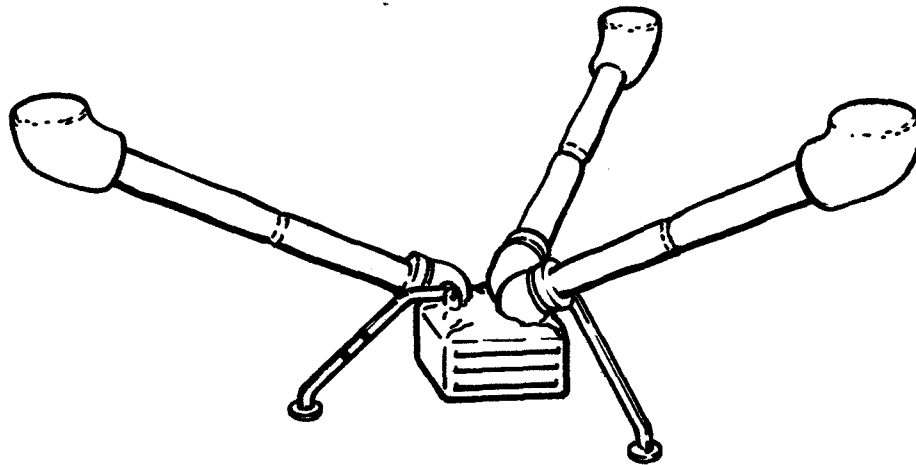

DEC 68 5178.1.11

SOLAR WIND SPECTROMETER

NASA No. S035

OBJECTIVE: SOLAR WIND - MOON, RADIATION EFFECTS ON SURFACE
THROUGH SPATTERING & CHARGING, PRESENCE OF ATMOSPHERE,
GROSS ELECTRICAL CONDUCTIVITY, EARTH'S TURBULENT WAKE

MEASUREMENT: POSITIVE ION & ELECTRON FLUX VARIATIONS WITH
ENERGY, TIME, & DIRECTION

EQUIPMENT: SEVEN
SENSORS COVERING
 2π STERADIANS

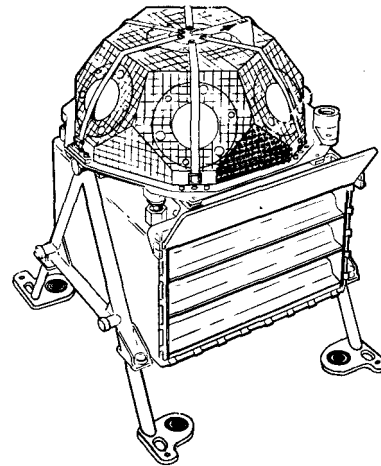

DEC 68 5178.1.12

SUPRATHERMAL ION DETECTOR

NASA No. SO 36

OBJECTIVE: IONOSPHERE/ATMOSPHERE CHARACTERISTICS, POSSIBILITY OF VOLCANIC PROCESSES, AMBIENT ELECTRIC FIELD EFFECTS

MEASUREMENT: FLUX, COMPOSITION, ENERGY, & VELOCITY OF LOW-ENERGY POSITIVE IONS; HIGH-ENERGY SOLAR WIND FLUX; TOTAL PRESSURE

EQUIPMENT: TWO CURVED - PLATE ANALYZERS (ONE WITH VELOCITY FILTER), GROUND PLANE, COLD CATHODE ION GAUGE

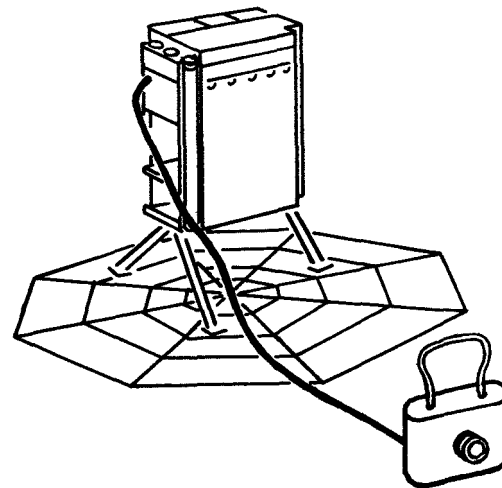

DEC 68 5178.1.13

HEAT FLOW

NASA No. S037

OBJECTIVE: INTERNAL TEMPERATURE & COMPOSITION OF THE MOON.
FROM THIS, INFERENCES CAN BE MADE ON LUNAR EVOLUTION,
BULK COMPOSITION, CHEMICAL SORTING, INTERNAL ENERGY (IN-
CLUDING RADIOACTIVITY), & NEAR-SURFACE MATERIAL PROPERTIES

MEASUREMENT: TEMPERATURE GRADIENT & THERMAL CONDUCTIVITY TO
DETERMINE AVERAGE OUTWARD HEAT FLUX AT THE SURFACE

EQUIPMENT: APOLLO LUNAR SURFACE DRILL; TWO PROBES, 1-IN. DIAM
X 43 IN. LONG, WITH HEATING ELEMENTS & TEMPERATURE SENSORS;
PROBES PLACED AT BOTTOM OF 10 - FT HOLES

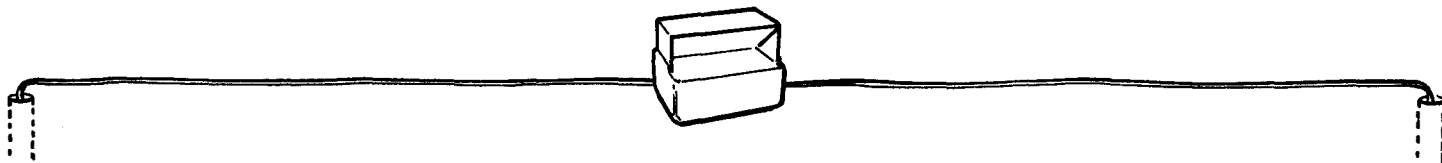

DEC 68 5178.1.14

CHARGED-PARTICLE LUNAR ENVIRONMENT

NASA No. S038

OBJECTIVE: ENERGY SPECTRUM OF LUNAR
ATMOSPHERE, LOW-ENERGY COSMIC
RAY PARTICLES, SOLAR WIND &
MAGNETOSPHERE EFFECTS

MEASUREMENT: ENERGY DISTRIBUTION &
VARIATION WITH TIME OF ELECTRON
& PROTON FLUX

EQUIPMENT: TWO DETECTOR PACKAGES,
EACH WITH SIX DETECTORS

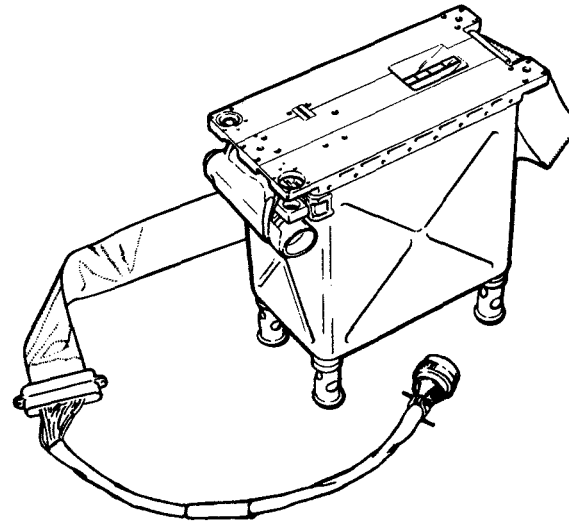

APR 69 5178.1.15

ALSEP AND THE FUTURE

ALSEP IS A FORERUNNER IN EQUIPMENT FOR LUNAR & SPACE EXPLORATION
CONSTRAINED BY EARLY AVAILABILITY, WEIGHT, AND SIZE

POSSIBLE FUTURE GOALS

	<u>NEW EXPERIMENTS</u>	<u>MULTIPLE LOCATIONS</u>
UNDER PRELIM DEVELOP- MENT	<ul style="list-style-type: none">● METEOROID SPECTROMETER● GRAVIMETER● LUNAR ELECTRIC FIELD● NEUTRAL MASS SPECTROMETER● OPTICAL & RADAR OBSERVATORIES	<ul style="list-style-type: none">● LATERAL VARIATIONS OF GRAVITY, ETC.● SEISMIC PHASE VELOCITY & DIRECTION● MEASUREMENT REDUNDANCY

VEHICLE - BORNE EXPERIMENTS

- GEOCHEMISTRY & GEOPHYSICAL TRAVERSE
- DEEP DRILLING

OCT 67 5178.1.16

SYSTEM REQUIREMENTS AND CONSTRAINTS

- LM INSTALLATION
 - MASS PROPERTIES
 - PRELAUNCH OPERATIONS
 - LAUNCH, FLIGHT AND LANDING
- REMOVAL FROM LM
 - ASTRONAUT INTERFACE
 - LUNAR ENVIRONMENT
 - DATA TRANSMISSION AND RECEPTION
 - GENERAL DESIGN CRITERIA

OCT 67 5178.2.1

INSTALLATION IN LUNAR MODULE

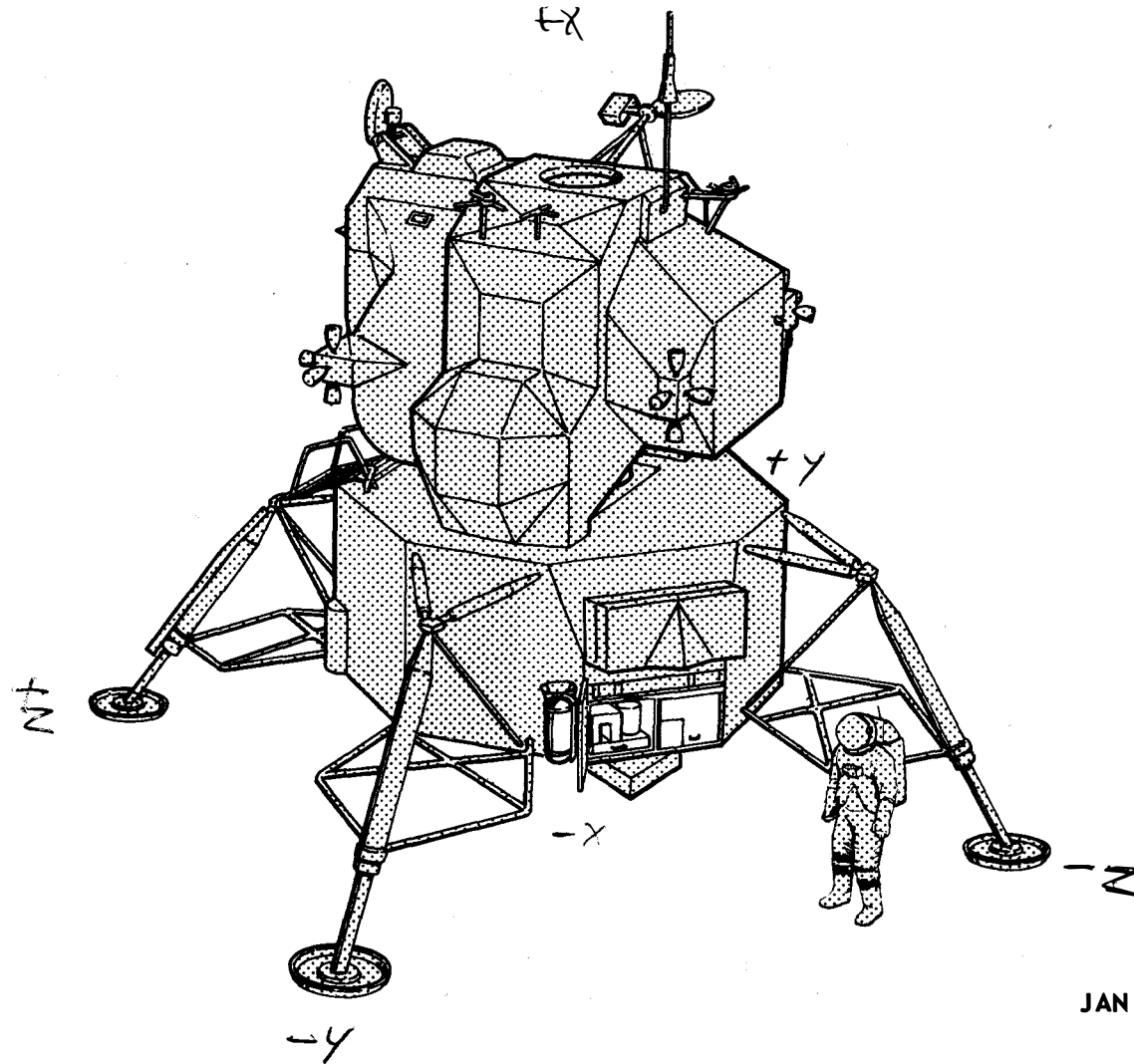

JAN 69 5178.2.2

PRELAUNCH INSTALLATION

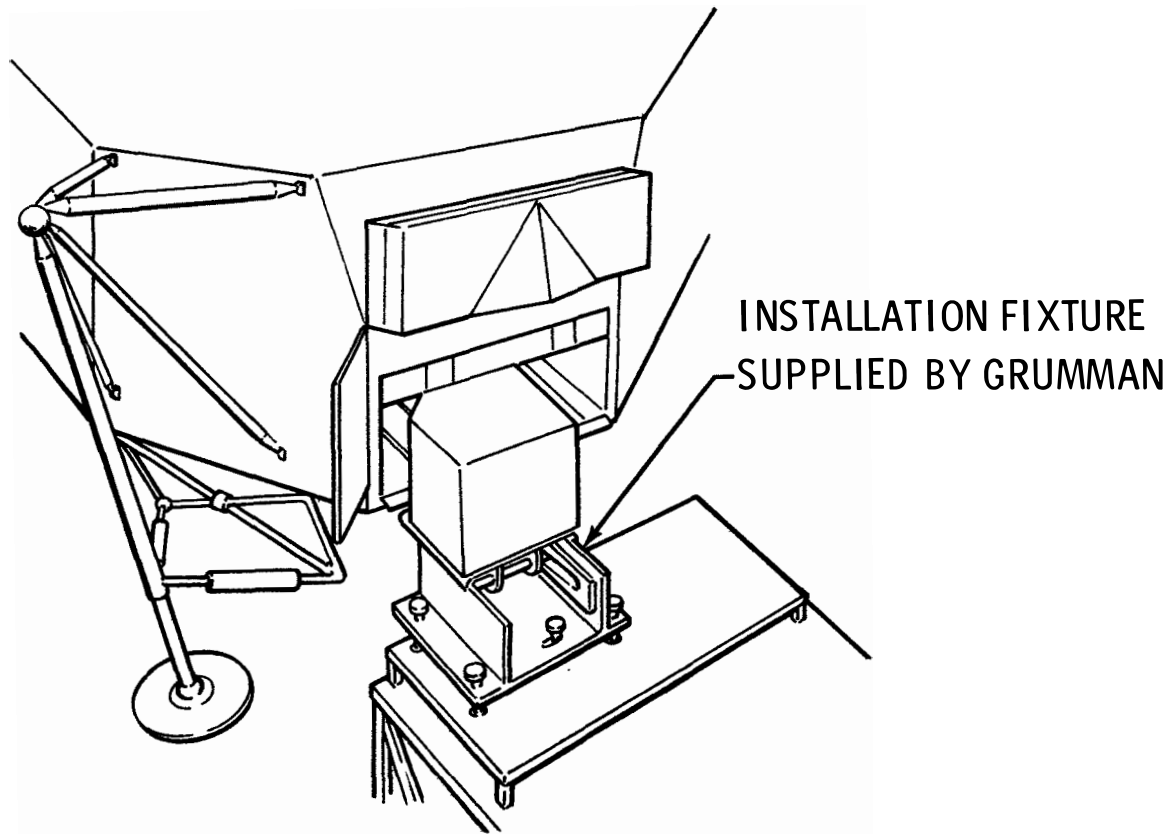

JAN 69 5178.2.3

ALSEP/LM GEOMETRY

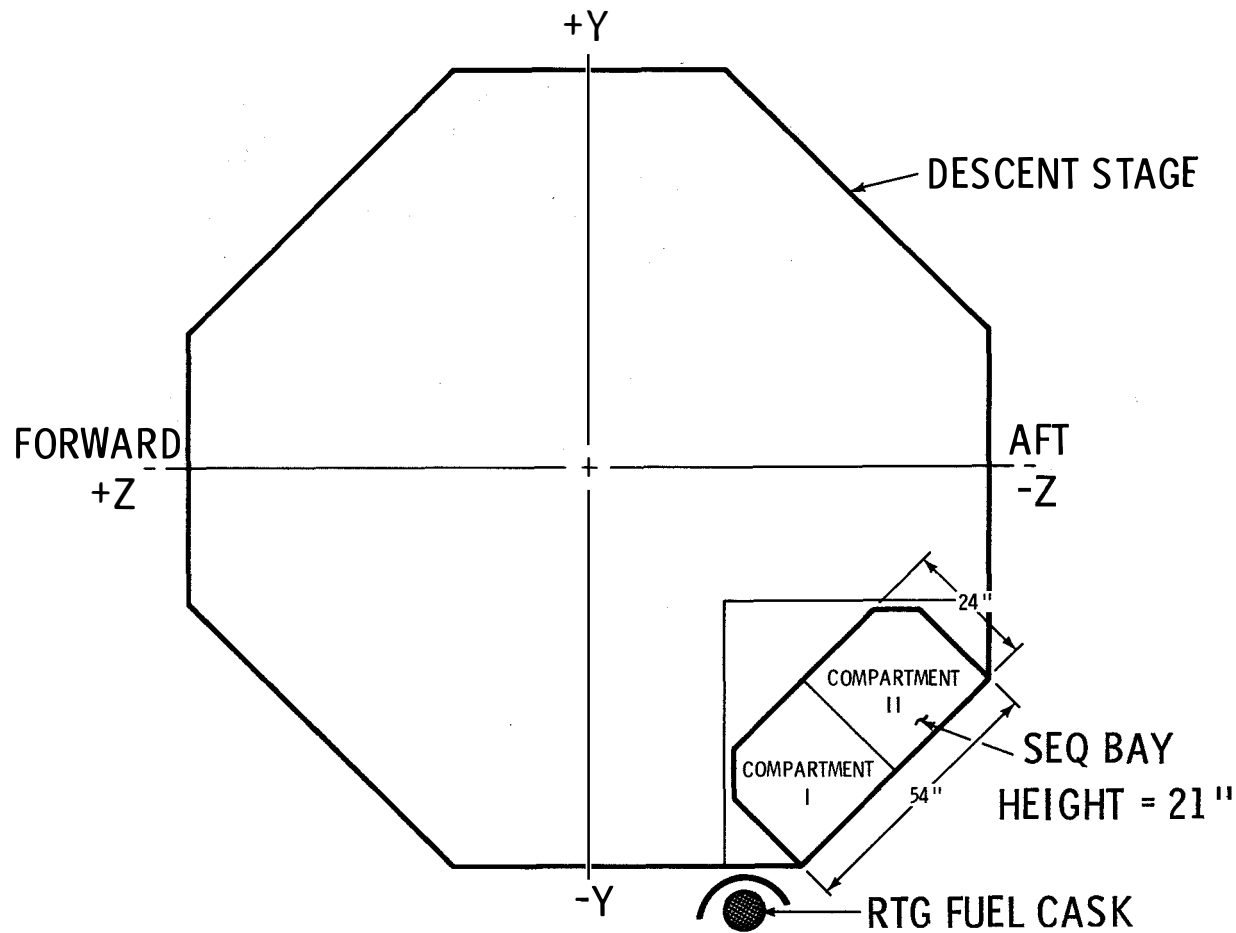

OCT 67 5178.2.4

STOWED CONFIGURATION

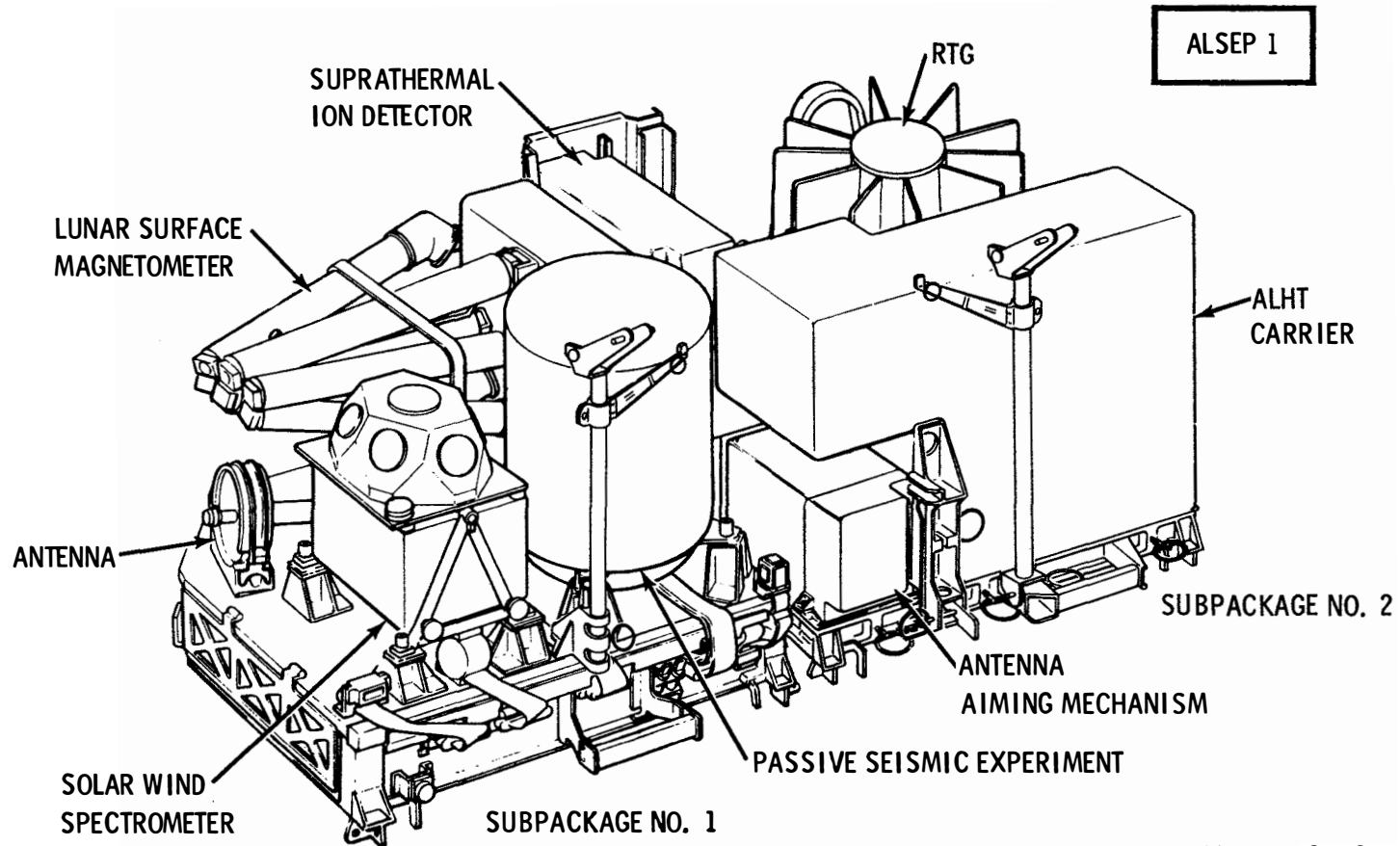

JAN 69 5178.2.5

LM HARD POINTS

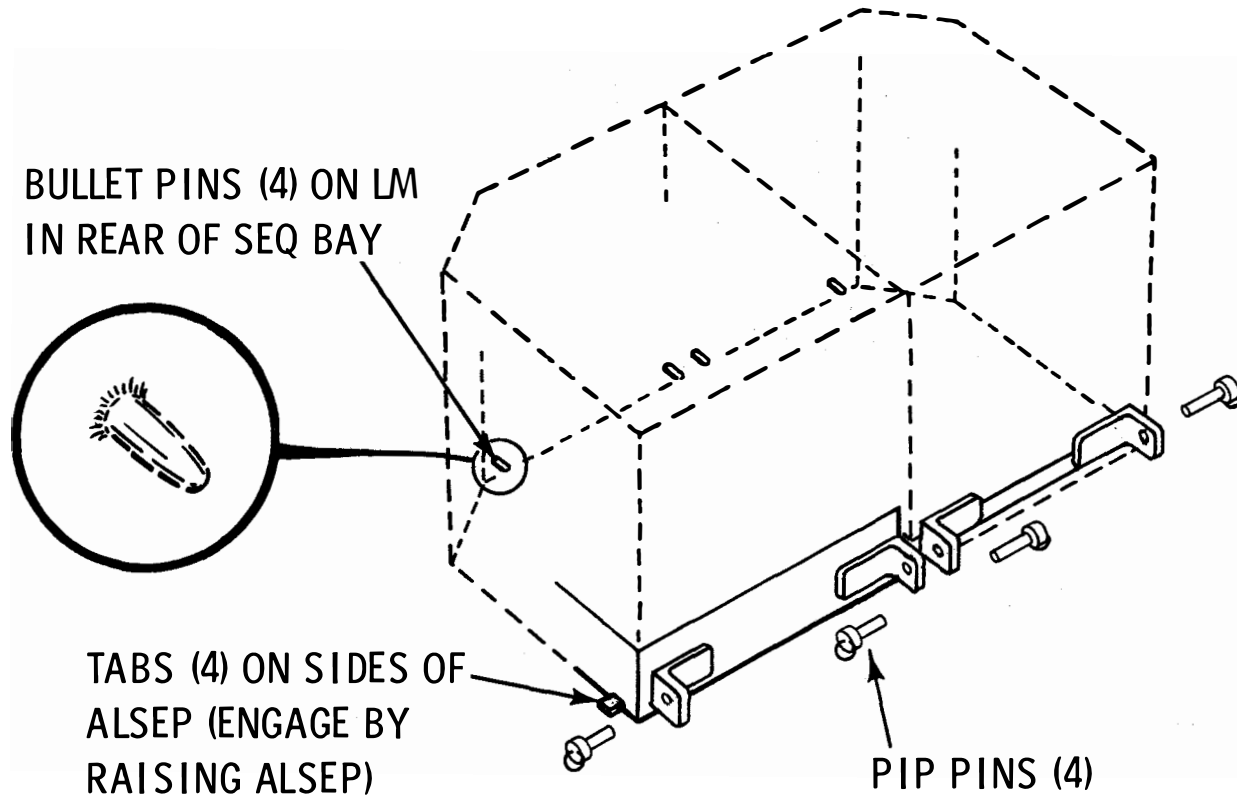

JAN 69 5178.2.6

MASS PROPERTIES

RESTRICTIONS

MAX WT IN DESCENT STAGE = 210 LB

LOADING IN BOTH COMPARTMENTS:

MINIMUM WT = 50 LB

MAXIMUM WT = 215 LB

(EXTERNAL CASK NOT INC)

C G DISTANCE FROM
GEOMETRIC CENTER
OF COMPARTMENT
(INCHES)

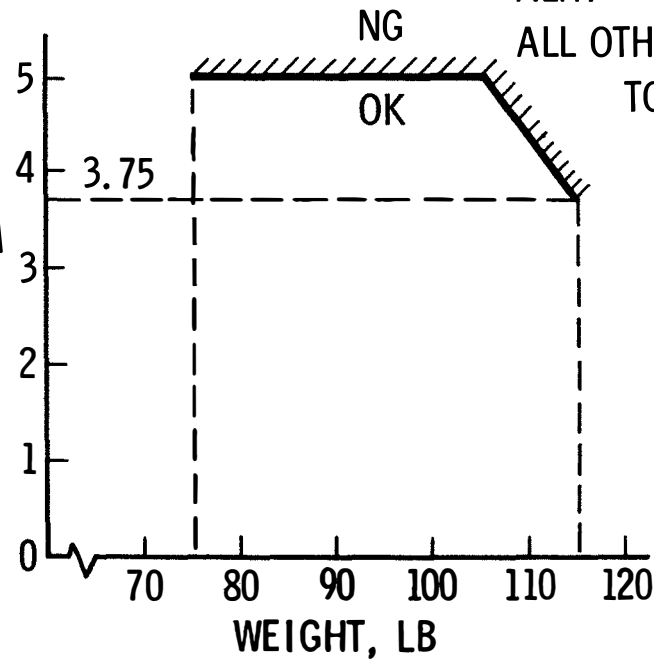

EXPERIMENTS 50.7 LB

POWER (GFE ONLY) 68.2

LM ALLOWANCE 5.0

ALHT 18.0

ALL OTHER (CFE) 140.8

TOTAL 282.7 LB

JAN 69 5178.2.7

PRELAUNCH OPERATIONS

- STORAGE UP TO 2 YRS IN CONTROLLED ENVIRONMENT
- CHECKOUT PRIOR TO LM INSTALLATION (INC MSFN TESTS)
- LM INSTALLATION IN LANDING GEAR CHECK FIXTURE
(BEFORE \approx F-60 DAYS)
- OPERATIONS AFTER S/C STACKING
 - FUEL CASK INSTALLATION ON LM
 - BATTERY INSTALLATION FOR ALSD, IF CARRIED
 - FUEL CAPSULE INSTALLATION IN CASK
- HEAT REMOVAL FROM CASK VIA CONDITIONED AIR
(1500 WATTS, NOMINAL)

GROUND SUPPORT EQUIPMENT

SYSTEM TEST SET

PROVIDES COMPLETE UPLINK, DOWNLINK
& CHECKOUT FUNCTIONS FOR FACTORY, KSC &
DURING MSFN TEST

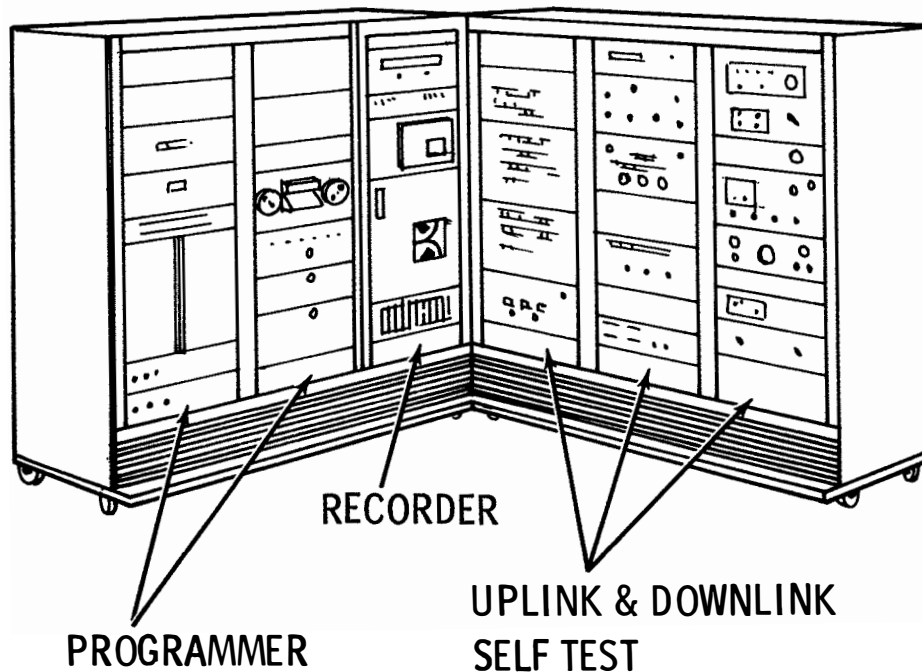

EXPERIMENT AUXILIARIES

MOST SENSORS CANNOT
BE OPERATED IN EARTH
ENVIRONMENT. THEREFORE,
FLUX TANKS & VACUUM
CHAMBERS ARE PROVIDED
FOR LIMITED END-TO-END
TESTS

MECH HANDLING EQUIP

LM INSTALLATION FIXTURE
SPECIAL EQUIPMENT
FOR RTG FUEL CAPSULE

APR 69 5178.2.9

LAUNCH, FLIGHT AND LANDING (STOWED IN SEQ BAY)

- ALSEP INACTIVE (NO ELECTRICAL INTERFACE)
- LAUNCH SHOCK & VIBRATION (TYPICAL SPACECRAFT ENVIRONMENTS)
- SEA LEVEL PRESSURE TO SPACE VACUUM
- TEMPERATURE CONTROLLED BY LM: 0° F TO 160° F (MAXIMUM VALUE OCCURS POST - TOUCHDOWN)
- HEAT LOADS FROM CASK TO LM < 100 BTU/HR TENTATIVE
- TOUCHDOWN DYNAMIC LOADS: 8g FOR 10 - 20 MS (ANY AXIS)
PLUS 14 RAD/SEC² ROTATION ACCEL (AROUND LATERAL AXIS)

REMOVAL FROM LUNAR MODULE

- BOTTOM OF SEQ BAY 18 IN. TO 60 IN. FROM SURFACE
& $\pm 15^\circ$ TILT (ANY DIRECTION)
- CLOSE LM DOOR FOR THERMAL INTEGRITY
- LANDING LOCATION WITHIN $\pm 5^\circ$ FROM EQUATOR & $\pm 45^\circ$ E - W
- LM PROBABLY LANDS FACING NW OR SW
- SUN ANGLE 7° TO 20° (POSSIBLE 45°)
ABOVE HORIZON AND RISING
- ALHT REMOVAL SEPARATELY OR
ATTACHED TO ALSEP

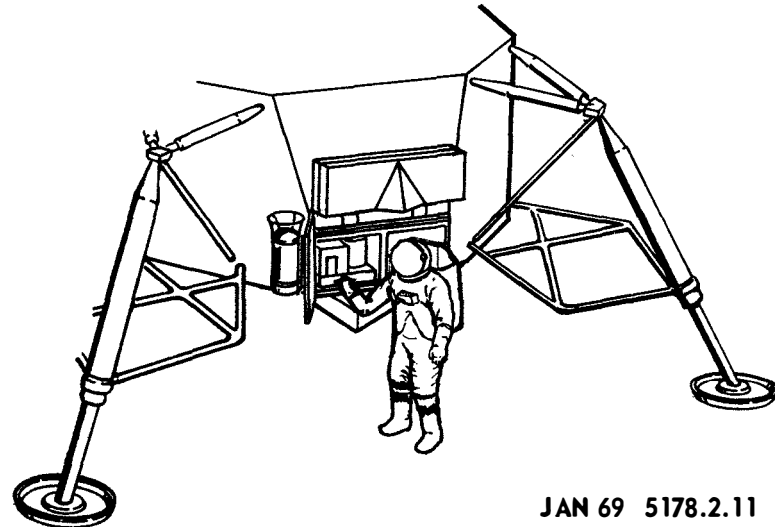

JAN 69 5178.2.11

ASTRONAUT INTERFACE

SAFETY

BIOMED: WITHIN EXERTION AND LIFE SUPPORT LIMITATIONS

TEMPERATURES: NO CONTACT WITH EXTREMELY HOT SURFACES

PUNCTURES: NO SHARP EDGES, ETC.; NO HAZARDOUS PYROTECHNICS

CAPABILITY

MOBILITY: LIMITATIONS ON REACH (UP & DOWN), KNEELING, TWISTING, ETC.

DEXTERITY: KNOBS & HANDLES SIZED TO FIT GLOVES, MINIMUM USE OF FINE
ADJUSTMENTS, FEW ELECTRICAL CONNECTORS MATED ON MOON

VISUAL: INDICATORS (LEVELING & ALIGNMENT) PROVIDE HIGH CONTRAST;
STRIPES ON PACKAGE EDGES WHERE THERMAL DESIGN PERMITS

BARBELL CARRY

- ALLOWS ALL EQUIPMENT TO BE CARRIED BY ONE MAN
IN ONE TRAVERSE
- SUITCASE HANDLES FOR TWO-MAN OR BACKUP
CARRY MODE
- GIVES GOOD BALANCE & VIEW OF FEET
- EQUIVALENT EARTH WEIGHT \approx 35 LB

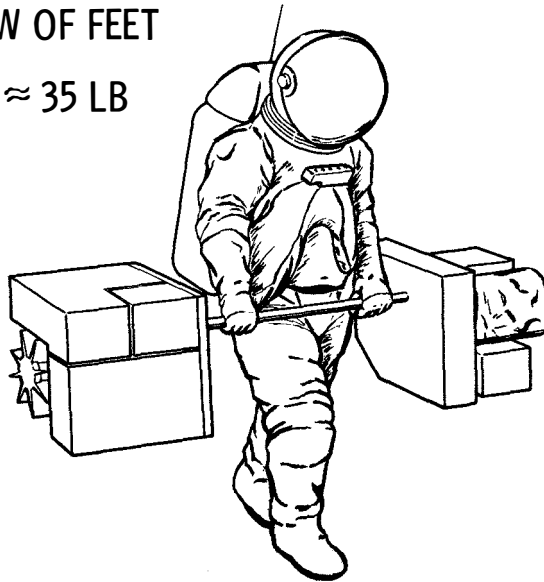

- MAY BE SET DOWN
TO REST
- CARRY BAR LATER
USED AS ANTENNA
MAST

APR 69 5178.2.13

ASTRONAUT PLSS CONSTRAINTS

2500 FT COMM LIMIT

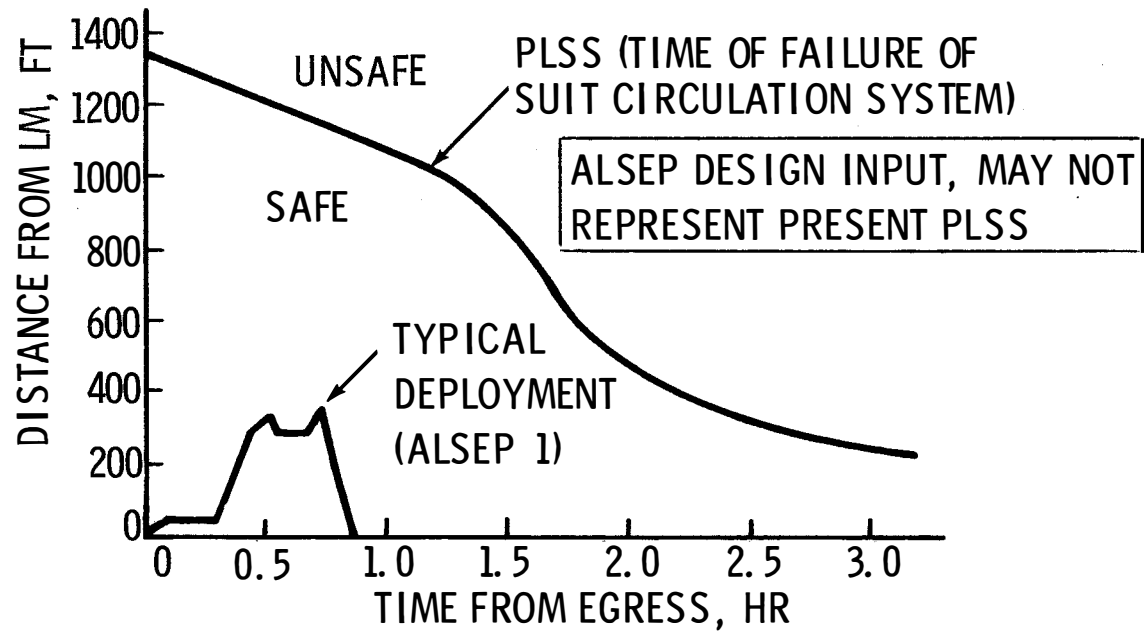

DEPLOYMENT FOR ALSEP 1

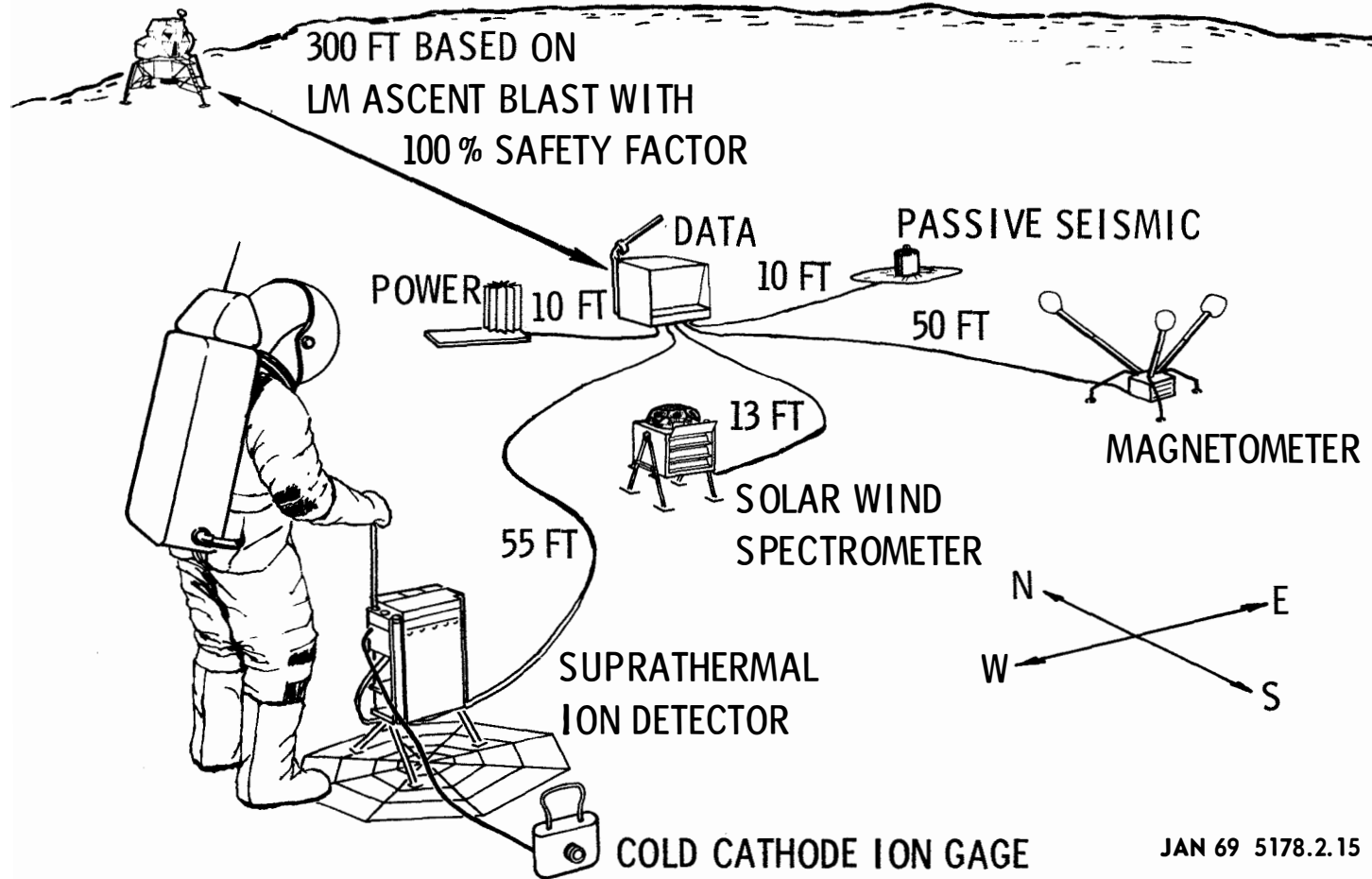

LUNAR ENVIRONMENT

(SPECIFICATION LED 520 - 1D)

SURFACE TEMPERATURE: - 300° F TO +250° F

SURFACE SLOPES: LESS THAN 12° "EFFECTIVE" SLOPE OVER SPACING OF LM LANDING GEAR (SELECTED SITES). SELECTABLE LOCATIONS FOR ALSEP LESS THAN 5° SLOPES

BEARING STRENGTH: COMBINATION OF SOFT (1 PSI PENETRATES 4 IN) & HARD (INFINITELY RIGID ROCK)

FRICTION COEFFICIENT: 0.4 to 1.0

OPTICAL PROPERTIES: LUNAR NORMAL ALBEDO (0.047 OVER SOLAR SPECTRUM, 0.098 OVER VISIBLE SPECTRUM) PLUS UNIQUE DIRECTIONAL REFLECTIVITY

PRESSURE: LESS THAN 10^{-12} TORR

MICROMETEORS: MSC DOCUMENT DS-21 APPLIES

RADIATION: NEGLIGIBLE EFFECT ON SYSTEM ELECTRONICS FOR ONE-YEAR OPERATION

OCT 67 5178.2.16

DATA TRANSMISSION AND RECEPTION

MAXIMUM COMPATIBILITY WITH APOLLO
PROCEDURES & HARDWARE AT MSFN
NON-INTERFERENCE WITH
APOLLO COMMUNICATIONS

WORLD - WIDE
REMOTED SITES
OF MSFN

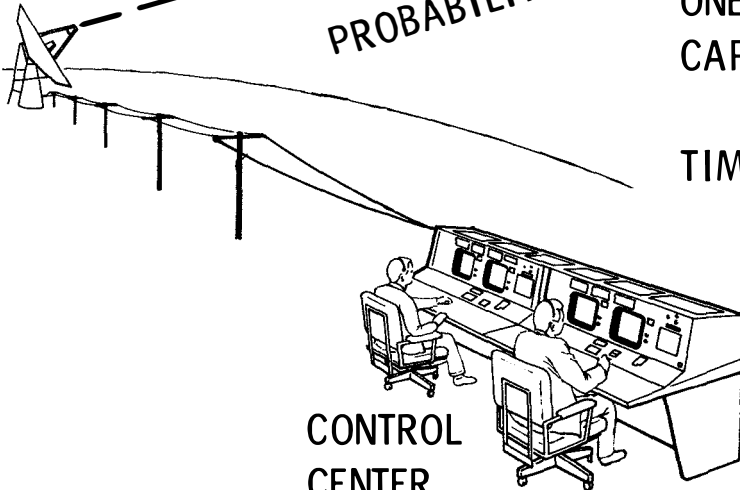

PROBABILITY OF BIT ERROR 10^{-9} OR BETTER
UPLINK 100 DIFFERENT COMMANDS
DOWNLINK 1060 BITS/SEC DATA (NORMAL)
PROBABILITY OF BIT ERROR 10^{-4} OR BETTER

ONE YEAR CONTINUOUS OPERATION
CAPABILITY FOR HANDLING
3 ALSEPs SIMULTANEOUSLY
TIMER TURN-OFF (2 YEAR) IN
CASE OF COMMAND
MALFUNCTION

CONTROL
CENTER

MONITOR REAL-TIME DATA
INITIATE COMMANDS

OCT 67 5178.2.17

ANTENNA POINTING REQUIREMENTS

LUNAR LIBRATION: AN APPARENT WOBBLING MOTION AS VIEWED FROM THE EARTH; CAUSES EQUIVALENT EARTH MOTION IN LUNAR COORDINATES

PRINCIPAL EFFECTS:

$\pm 7.5^\circ$ LUNAR LONGITUDE DUE TO:

CONSTANT ANGULAR RATE OF MOON ABOUT ITS AXIS

VARIABLE ANGULAR RATE IN ELLIPTICAL ORBIT AROUND EARTH

$\pm 6.5^\circ$ LUNAR LATITUDE DUE TO:

INCLINATION OF MOON'S ROTATION AXIS TO ITS ORBITAL PLANE

SECONDARY EFFECTS:

NON-SPHERICAL EARTH & MOON

SOLAR PERTURBATIONS

GYROSCOPE & PENDULUM COUPLING

COMBINED EFFECTS: PATTERN CHANGES

MONTHLY & YEARLY

ALSEP ANTENNA: 22° BEAM WIDTH DOWN

4.2 db AIMED AT MEAN CENTER OF PATTERN

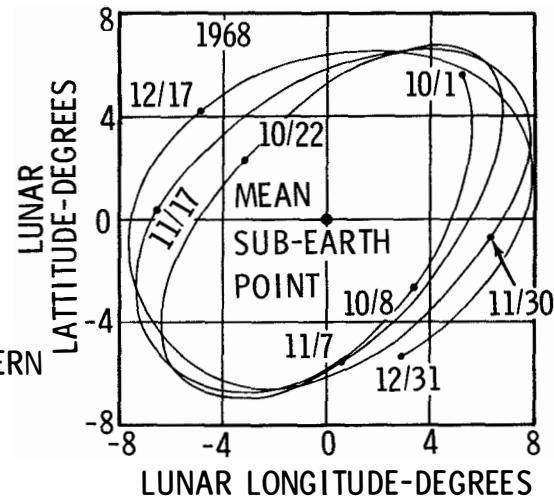

ALSEP / MSFN INTERFACE

REQUIREMENT	RESOLUTION																
APOLLO COMPATIBILITY	S-BAND EQUIPMENT, ESSENTIALLY SAME AS APOLLO; SCHEDULE SEPARATE MSFN SITES FOR APOLLO & ALSEP																
3 ALSEPS SIMULTANEOUSLY	<p style="text-align: center;"><u>UPLINK</u></p> ONE FREQ (2119 MHz) BUT UNIQUE COMMAND ADDRESSES FOR UP TO 4 ALSEPS	<p style="text-align: center;"><u>DOWNLINK</u></p> USE DUAL SITES; THREE XMTR FREQUENCIES (2276.5, 2278.5 & 2275.5 MHz)															
BIT ERROR RATE	<p>10^{-9}: 10 KW XMTR POWER & 15 db ALSEP ANTENNA</p> <table border="1" data-bbox="709 849 1104 943"> <tr> <td>MSFN</td> <td>30 - ft</td> <td>85 - ft</td> </tr> <tr> <td>S/N MARGIN</td> <td>+28 db</td> <td>+35 db</td> </tr> </table> <p>NOTE: XMTR TUNING FOR MAX POWER IS NOT CRITICAL (ASSUMED 30-MIN TURN-AROUND APOLLO TO ALSEP)</p>	MSFN	30 - ft	85 - ft	S/N MARGIN	+28 db	+35 db	<p>10^{-4}: 1 WATT MIN XMTR POWER & 15 db ALSEP ANTENNA</p> <p>NORMAL BIT RATE = 1.06 KBPS LOW BIT RATE = 0.53 KBPS (CONTINGENCY) HIGH BIT RATE = 10.6 KBPS (ACTIVE SEISMIC, ON REQUEST)</p> <p>S/N MARGIN:</p> <table border="1" data-bbox="1171 1105 1593 1243"> <tr> <td>MSFN</td> <td>30-ft</td> <td>85-ft</td> </tr> <tr> <td>1.06 KBPS</td> <td>+7.2 db</td> <td>HI</td> </tr> <tr> <td>10.6 KBPS</td> <td>LO</td> <td>+6.5 db</td> </tr> </table>	MSFN	30-ft	85-ft	1.06 KBPS	+7.2 db	HI	10.6 KBPS	LO	+6.5 db
MSFN	30 - ft	85 - ft															
S/N MARGIN	+28 db	+35 db															
MSFN	30-ft	85-ft															
1.06 KBPS	+7.2 db	HI															
10.6 KBPS	LO	+6.5 db															
2 - YEAR TIMER	BUŁOVA ACCUTRON 720 ± 30 DAYS																

NOV 67 5178.2.19

SPECIAL COMMUNICATIONS FEATURES

UPLINK

- ALTHOUGH ALSEP WAS AUTOMATED IN ORIGINAL CONCEPT, IT NOW DEPENDS ON ACTIVE USE OF MANY COMMANDS
- 100 POSSIBLE COMMANDS BUT EACH ALSEP USES 65 to 75
- NO COMMANDS REQUIRING PRECISE TIMING (+ 10 SEC IN PSE FORCED LEVELING)
- COMMAND CAPABILITY WITHIN 15 MIN HIGHLY DESIRED FOR \approx 15 ON/OFF SWITCHES
- ALSEP RECEPTION & IDENTIFICATION OF COMMANDS IS VERIFIED VIA TM
- UPLINK 1000 BPS, 61 BITS PER COMMAND
- COMMAND RATE NO MORE THAN 1/SEC

DOWNLINK

- NO DATA STORAGE IN ALSEP; HENCE, ALL DATA TRANSMITTED IN NEAR REAL TIME & 100 % COVERAGE IS DESIRED
- NORMAL MODE (1.06 KBPS) HAS 64 10- BIT WORDS/FRAME \approx 0.604 SEC/FRAME
- LOW BIT RATE HAS SAME FORMAT \approx 1.208 SEC/FRAME
- HIGH BIT RATE IS SPECIAL FORMAT FOR ASE
- EXCEPT FOR ASE, NO WORDS CAN BE INTERCHANGED BETWEEN EXPERIMENTS, ALL EXPERIMENTS OPERATE FULL-TIME & DATA IS INTERLACED IN FORMAT
- APPROX DISTRIBUTION OF DATA:
5 % SYNC, 10 % HOUSEKEEPING, 85 % SCIENCE

- START-UP WHILE ASTRONAUT IS ON SURFACE & BEGIN INITIAL INTERROGATION
- DUST COVERS ON PARTICLE EXPERIMENTS REMOVED AFTER LM ASCENT

APR 69 5178.2.20

MSFN/MCC SUPPORT REQUIREMENTS

- ALL RECEIVED DATA MUST BE RECORDED BY MSFN (UP TO 3 ALSEPS)
- EACH ALSEP MUST BE MONITORED REAL-TIME FOR FIRST 45 DAYS (i. e. , THROUGH SECOND SUNSET) FOR CRITICAL THERMAL TRANSIENTS PLUS SCIENCE
- AFTER 45 DAYS, REAL-TIME MONITORING FOR 2 CONTINUOUS HR PER 24 REQ'D (2 HR PER 8 HR DESIRED) FOR REMAINDER OF YEAR
- ADDITIONAL CONTINUOUS COVERAGE REQUIRED FOR 60 HOURS EACH TERMINATOR CROSSING (26 TIMES PER YEAR PER ALSEP)
- FOR MULTIPLE ALSEPS, USE TIME-SHARING OF INTERMITTENT MONITORING (NO MORE THAN TWO SIMULTANEOUSLY IN REAL TIME)
- HIGH BIT RATE FOR ASE (10.6 KBPS) TO BE COMPRESSED TO LESS THAN 2.4 KBPS FOR TRANSMISSION FROM REMOTED SITES TO MCC. NO OTHER ALSEP MONITORED REAL-TIME DURING ASE OPERATIONS
- PROFILE OF ALSEP OPERATIONS DAY/NIGHT TO BE DETERMINED

OCT 68 5178.2.21

STATION SELECTION FOR ALSEP

(MOON DECLINATION MAXIMUM NORTH)

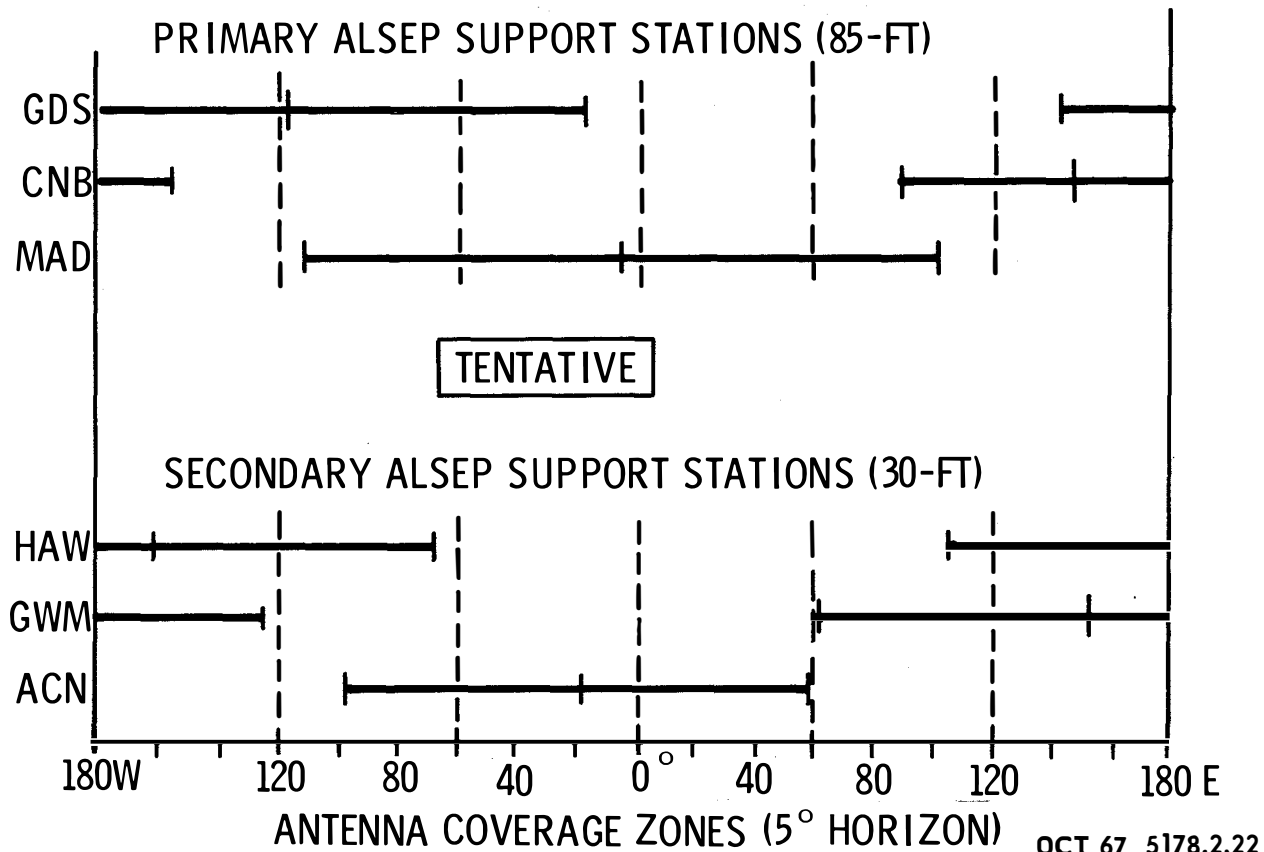

STATION SELECTION FOR ALSEP

(MOON DECLINATION MAXIMUM SOUTH)

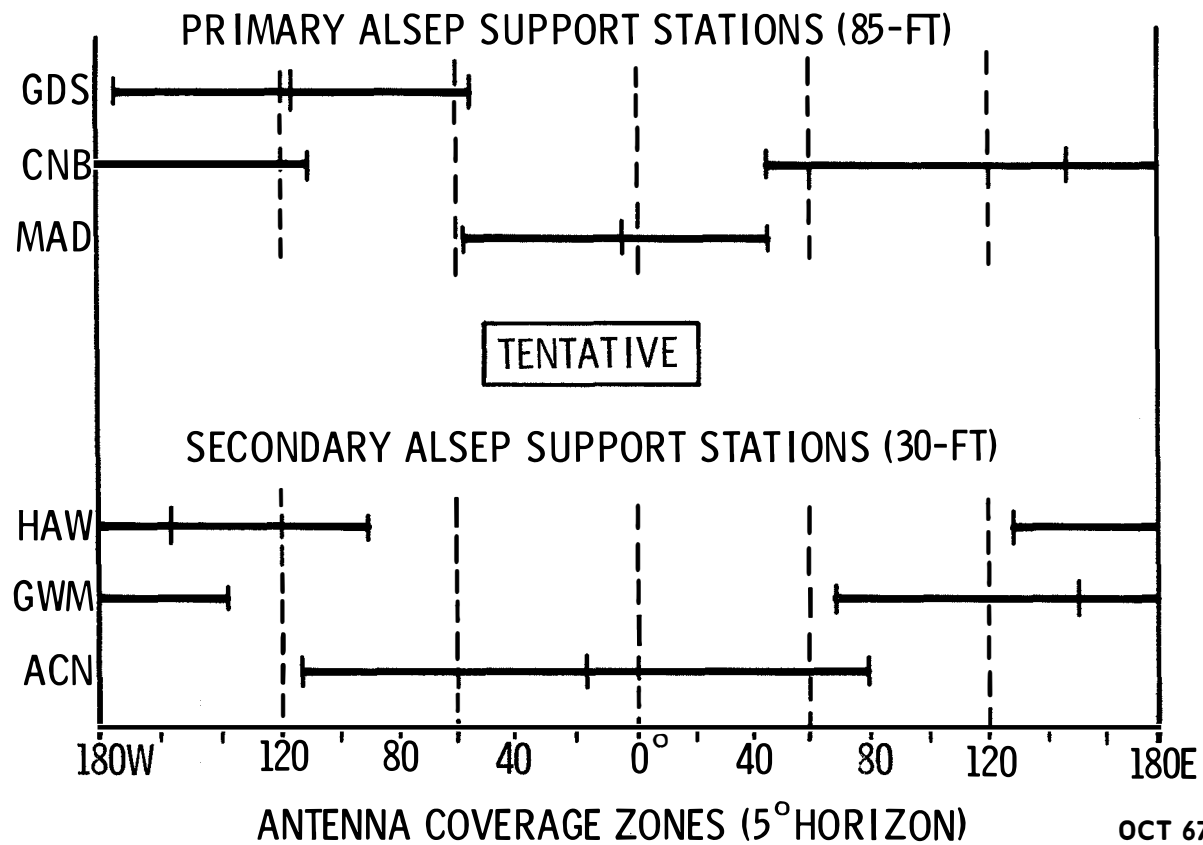

GENERAL DESIGN CRITERIA

CREW SAFETY: NO SHARP EDGES, CONTACT WITH HOT SURFACES, EXPOSED HIGH VOLTAGE POINTS, OR HAZARDOUS PYROTECHNICS (USE ONLY ASI)

THERMAL DEGRADATION: SYSTEM MUST PERFORM WHEN SURFACES ARE FULLY DEGRADED BY DUST OR UV

FAIL SAFE: MALFUNCTIONS MUST NOT PROPAGATE SEQUENTIALLY

PARTIAL OPERATIONS: SYSTEM MUST PERFORM WHEN ONE OR MORE EXPERIMENTS ARE NOT DEPLOYED OR HAVE FAILED

MATERIALS: WITHOUT NASA APPROVAL, NO FLAMMABLE, TOXIC, OR UNSTABLE MATERIALS & NO PLASTICS EXCEPT EPOXY RESIN-BASED COMPOUNDS, TEFLON, OR MYLAR

EMI: ALSEP COMPONENTS SHALL NEITHER BE A SOURCE OF EM DISTURBANCES NOR BE SUSCEPTABLE TO EXTERNAL SOURCES

GROUNDING: SEPARATE POWER & SIGNAL RETURNS; ONE COMMON GROUND POINT IN THE DATA SUBSYSTEM; SHIELDS CONNECTED TO CHASSIS GROUNDS AT BOTH ENDS

NOV 67 5178.2.24

SYSTEM LEVEL DESCRIPTION

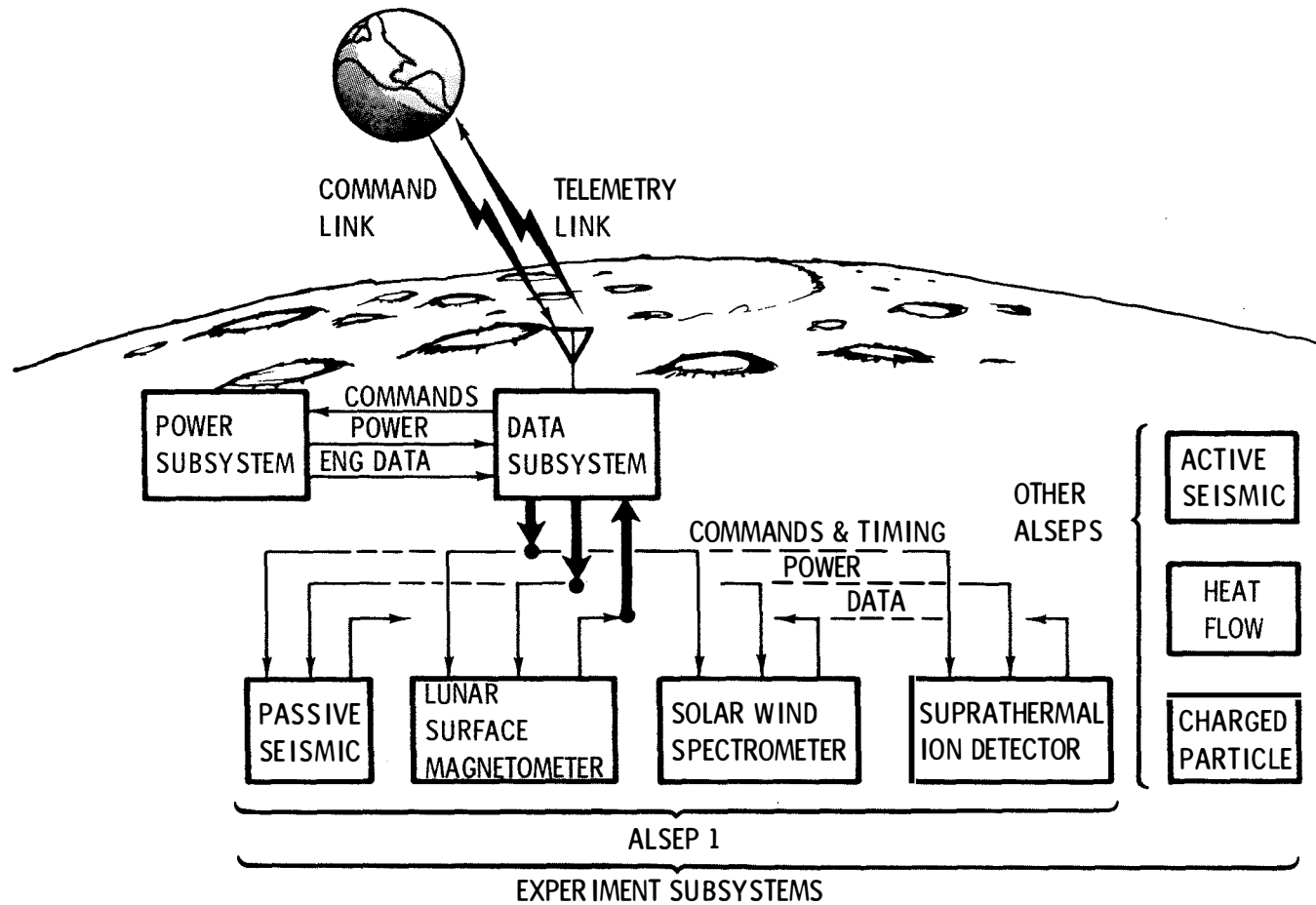

APR 69 5178.3.1

SYSTEM FUNCTIONAL DIAGRAM

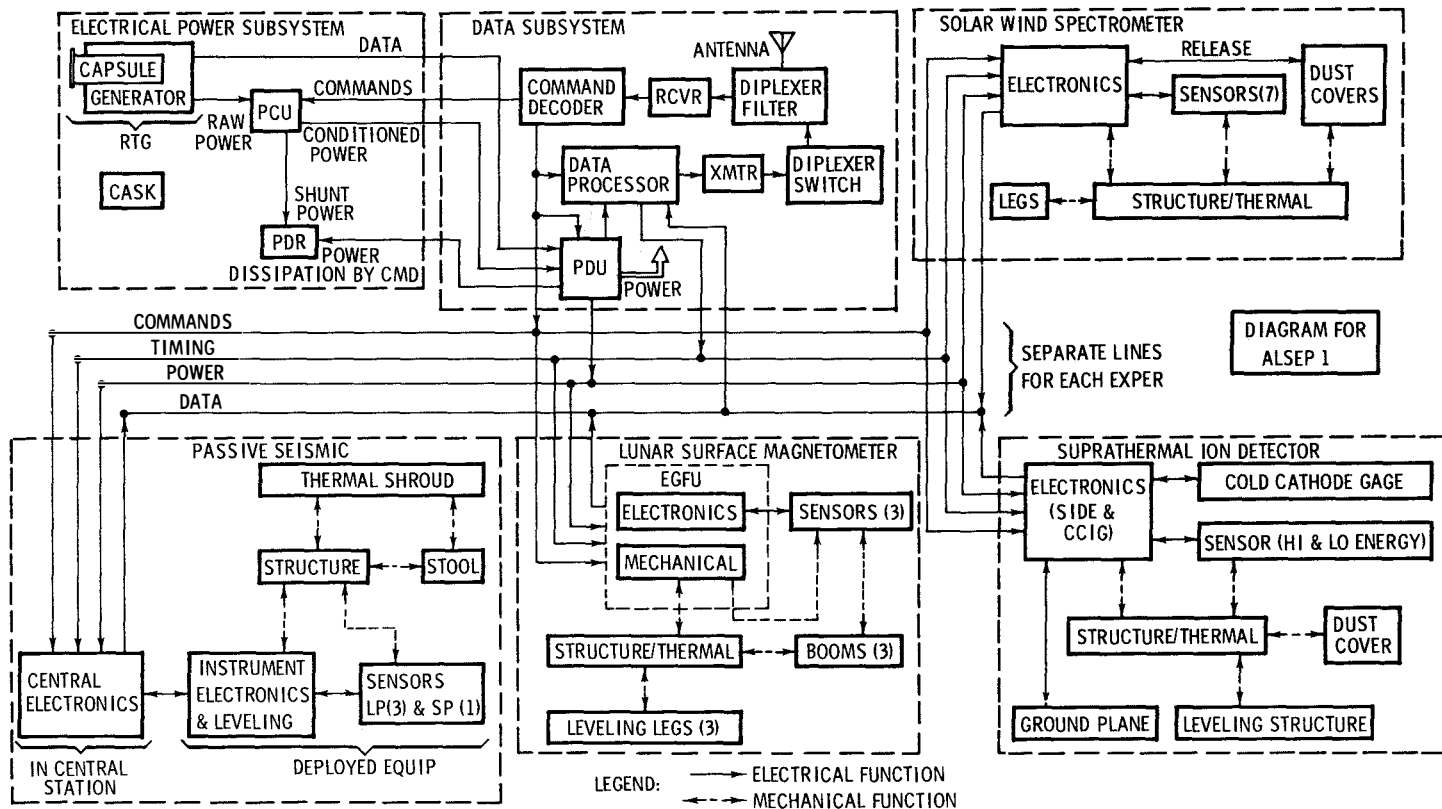

SYSTEM HARDWARE LIST

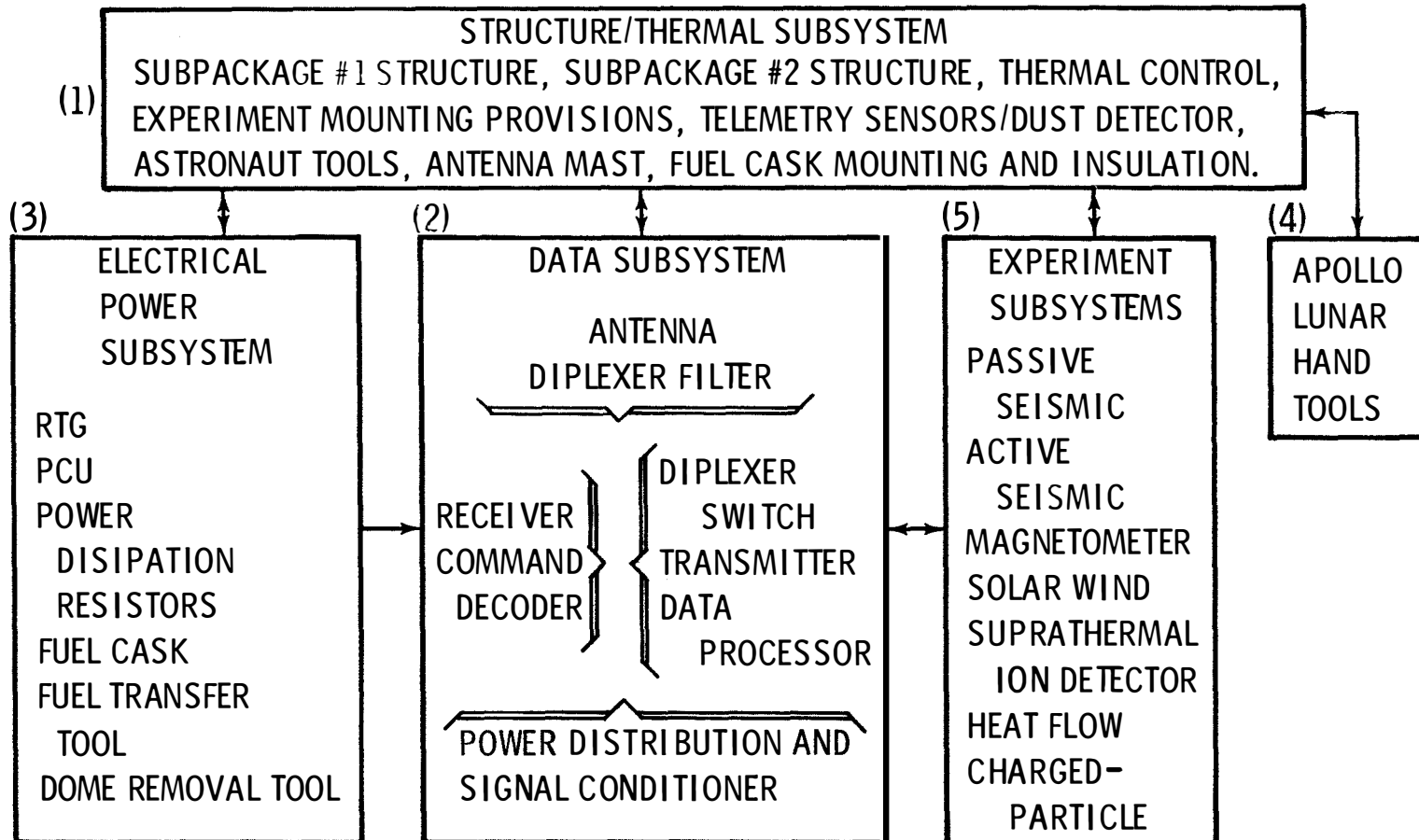
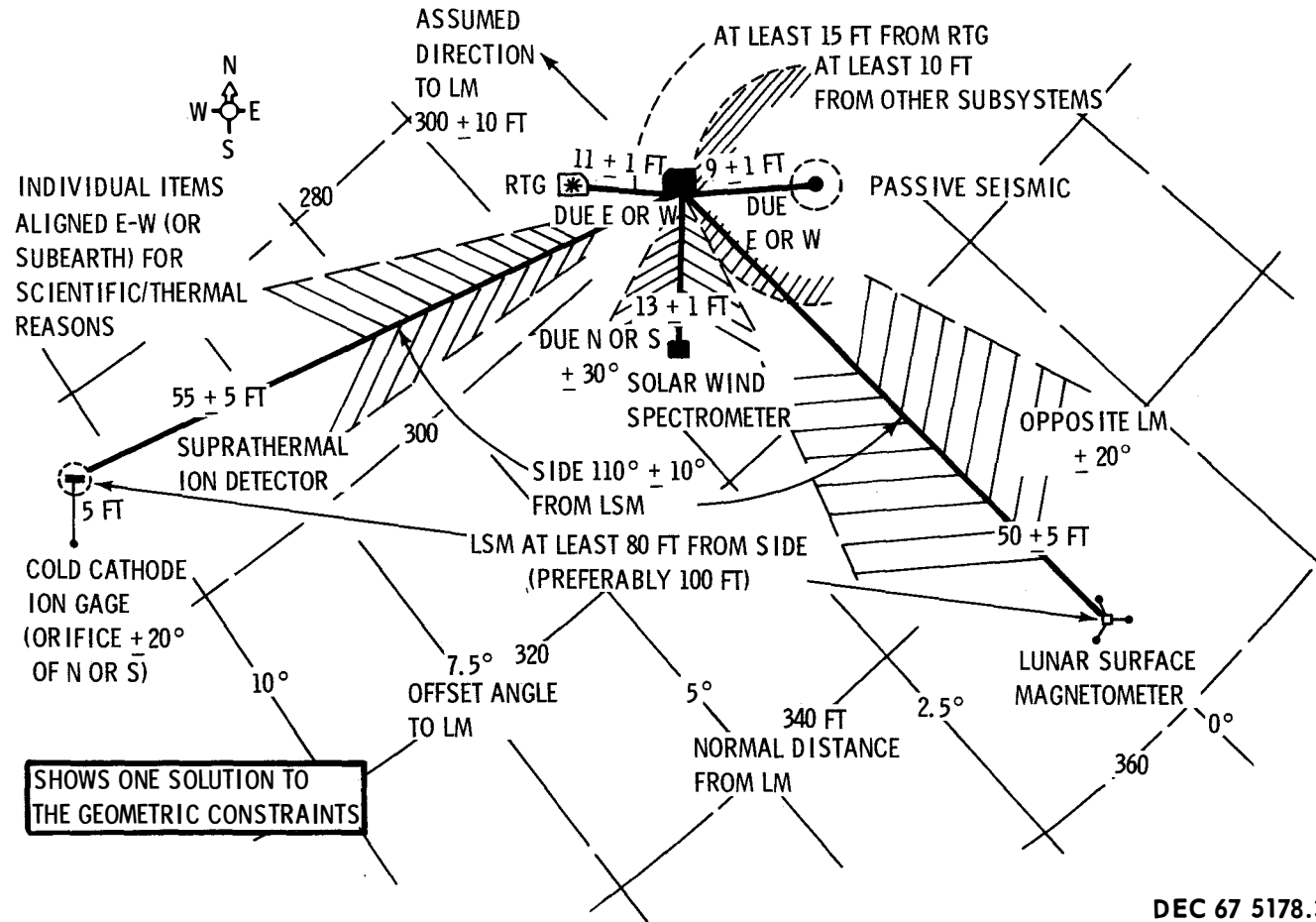
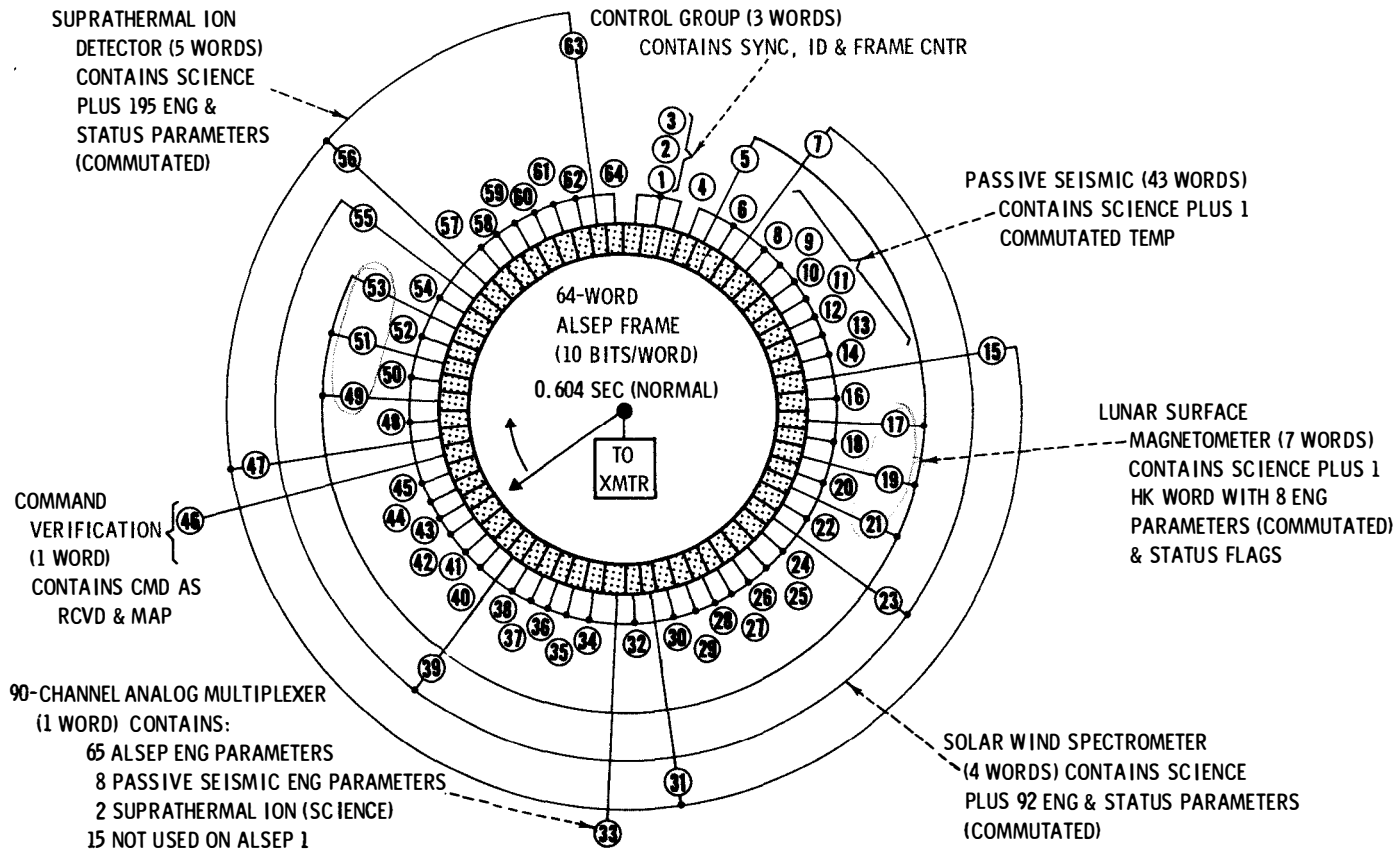

FIG. 1-1

ALSEP 1 SYSTEM GEOMETRY



ALSEP 1 SYSTEM DATA FLOW



OCT 68 5178.3.5

STRUCTURE/THERMAL SUBSYSTEM CHARACTERISTICS

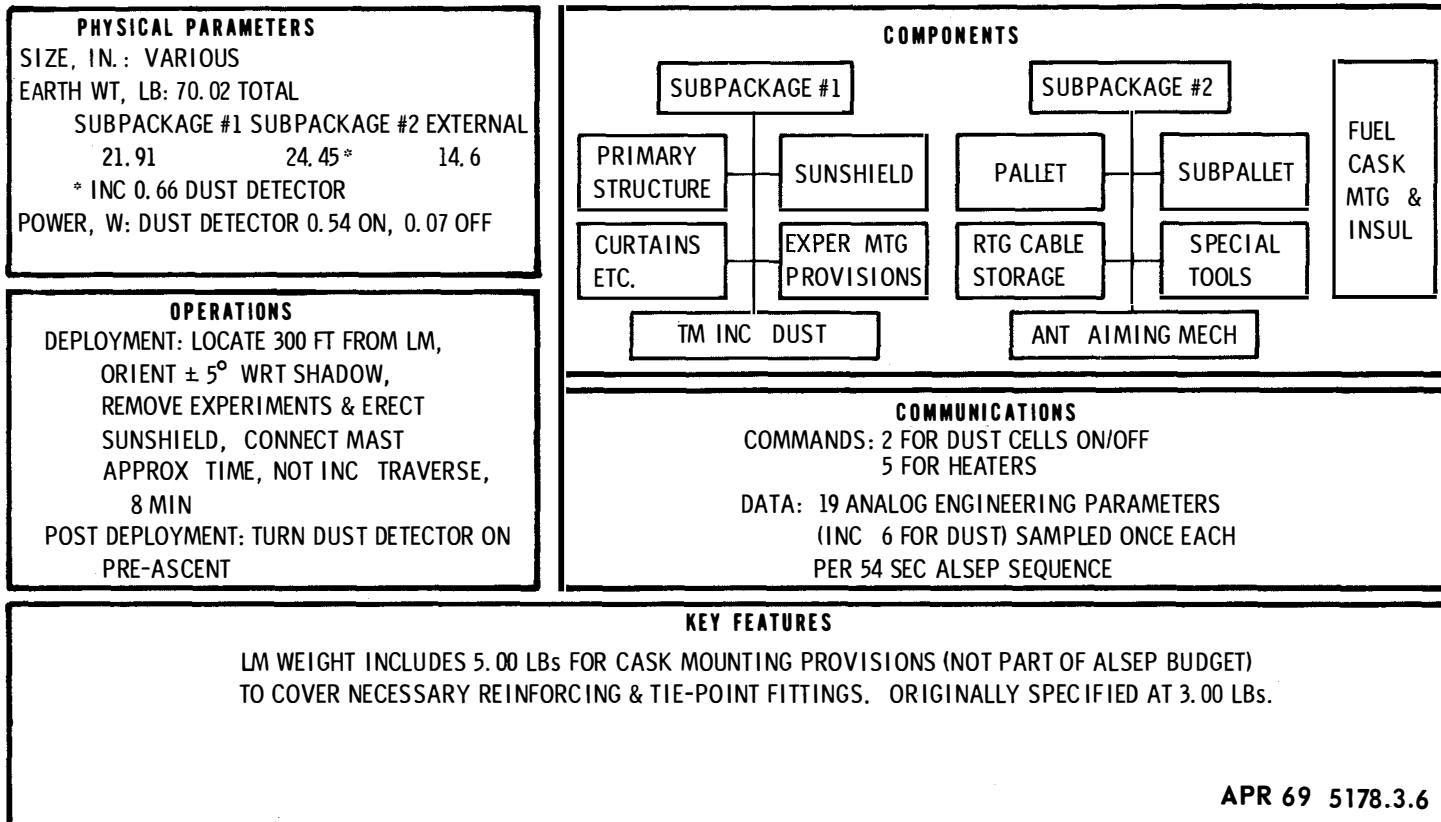

STRUCTURAL COMPONENTS

SUBPACKAGE #1 (21.91 LB)

SUBPACKAGE #2 (24.43 LB)

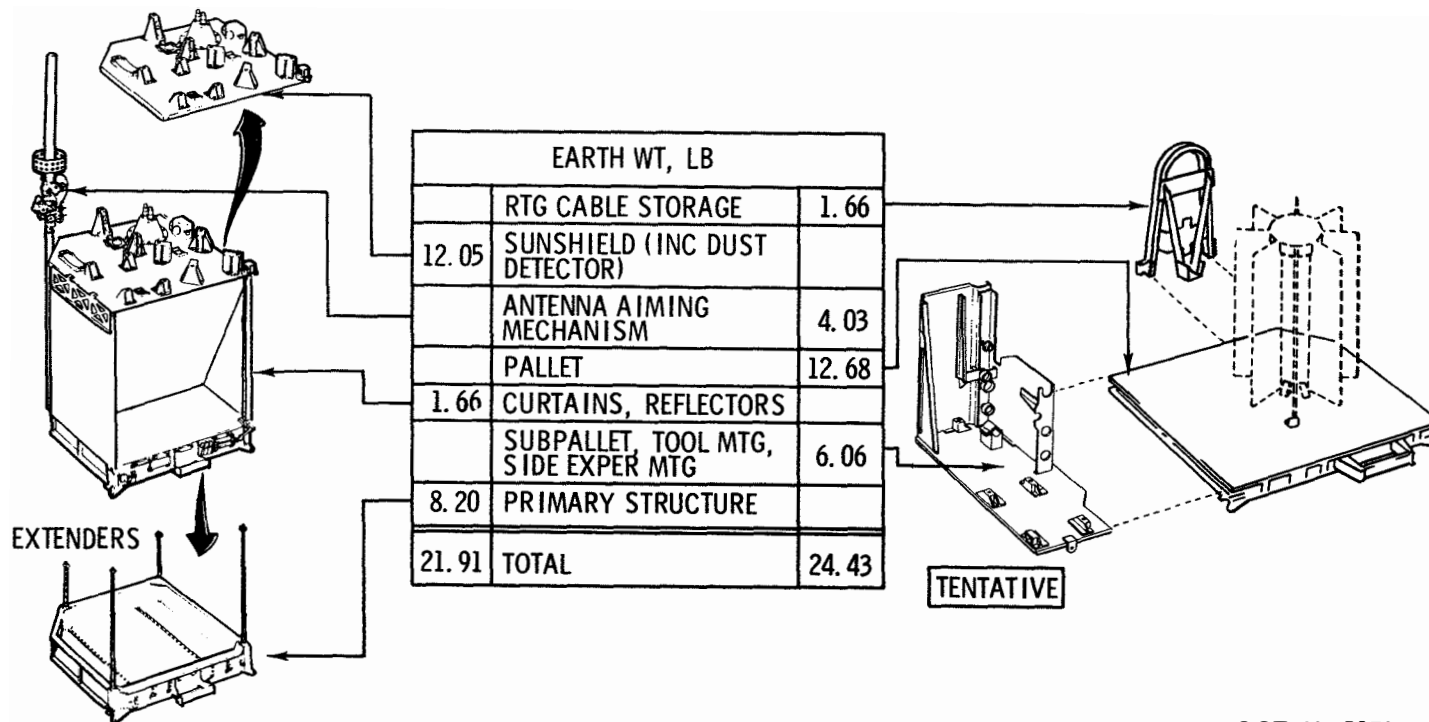

OCT 68 5178.3.7

THERMAL CONTROL

PHILOSOPHY: EACH SEPARATE UNIT CONTROLLED INDEPENDENTLY EXCEPT FOR ELECTRICAL HEATER POWER REQUIREMENTS

	PASSIVE RADIATION	MULTI-LAYER INSULATION	SUNSHIELD	CURTAINS	SPECULAR REFLECTOR	THERMOSTATICALLY CONTROLLED HEATER
RTG	R					
CENTRAL ELECTRONICS	C	I	C	B	C	J
PASSIVE SEISMIC		P	P	P		K
MAGNETOMETER	S/T	I			S	J
SUPRATHERMAL ION	T					L
SOLAR WIND	S	I	E		S	L
CHARGED-PARTICLE	T	I				K
ACTIVE SEISMIC	C/A	I	C/A	A		L
HEAT FLOW	C/H	I	C/H	B	C	L

LEGEND

- R = TOP & ALL SIDES
- C = COMBINED TOP & SUNSHIELD
- S/T = S FOR ELECTRONICS, T FOR SENSORS
- C/A = C FOR MORTAR PACKAGE ONLY
- C/H = C FOR PROBE ELECTRONICS ONLY
- T = TOP ONLY
- S = SIDES ONLY (NORTH & SOUTH FOR MAGNETOMETER, SOUTH ONLY FOR SOLAR WIND)
- I = INSULATED FROM LUNAR SURFACE
- P = COUPLED TO LOCAL LUNAR SURFACE
- E = EXTENDS OVER RADIATOR ON SIDE
- B = BIDIRECTIONAL, EAST & WEST
- A = ALL SIDES ON MORTAR PACKAGE

- J = COMMAND OVERRIDE OFF
- K = COMMAND OVERRIDE ON/OFF
- L = NO COMMAND OVERRIDE

SUBPACKAGE #1 THERMAL COMPONENTS

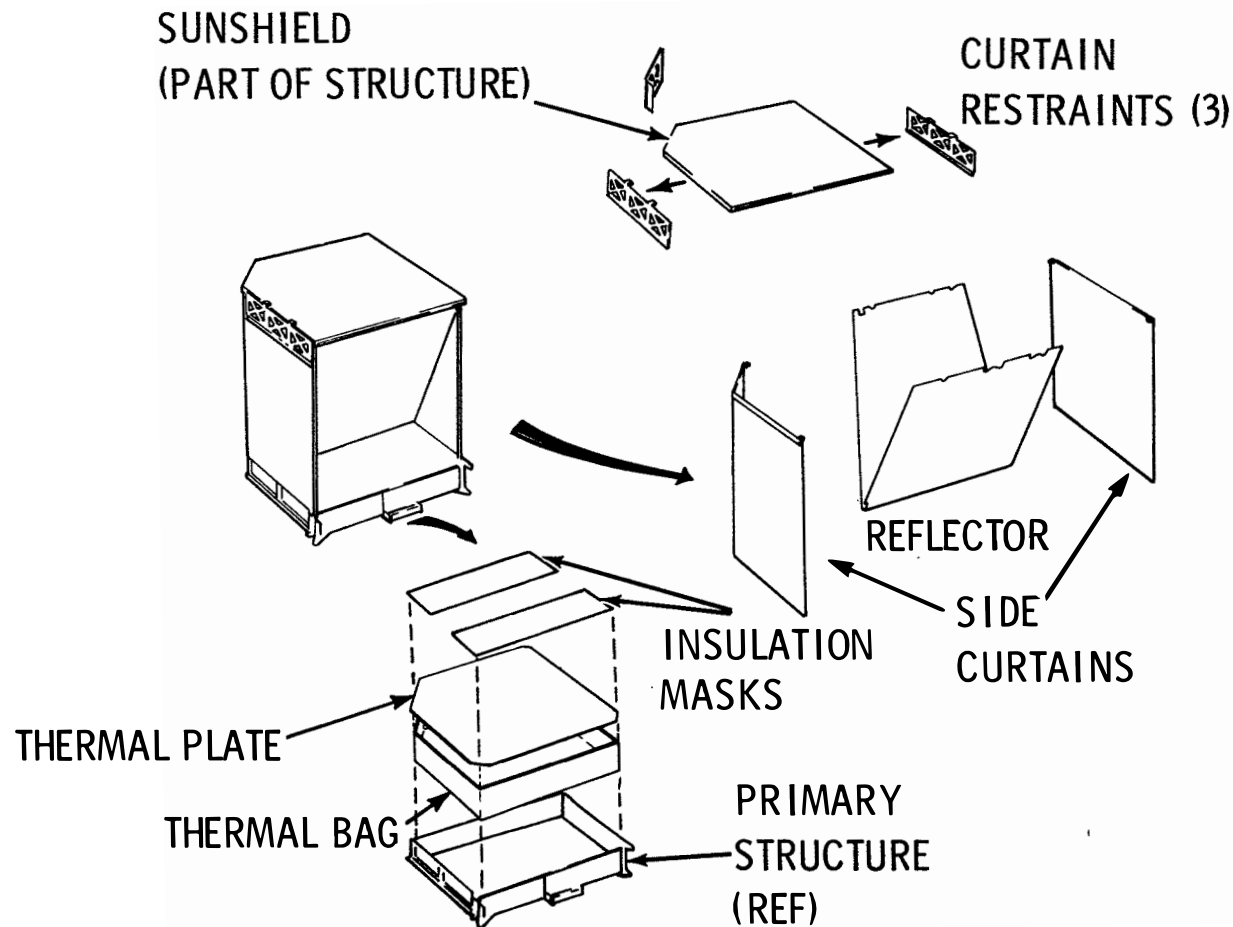

OCT 68 5178.3.9

EXPERIMENT MOUNTING PROVISIONS

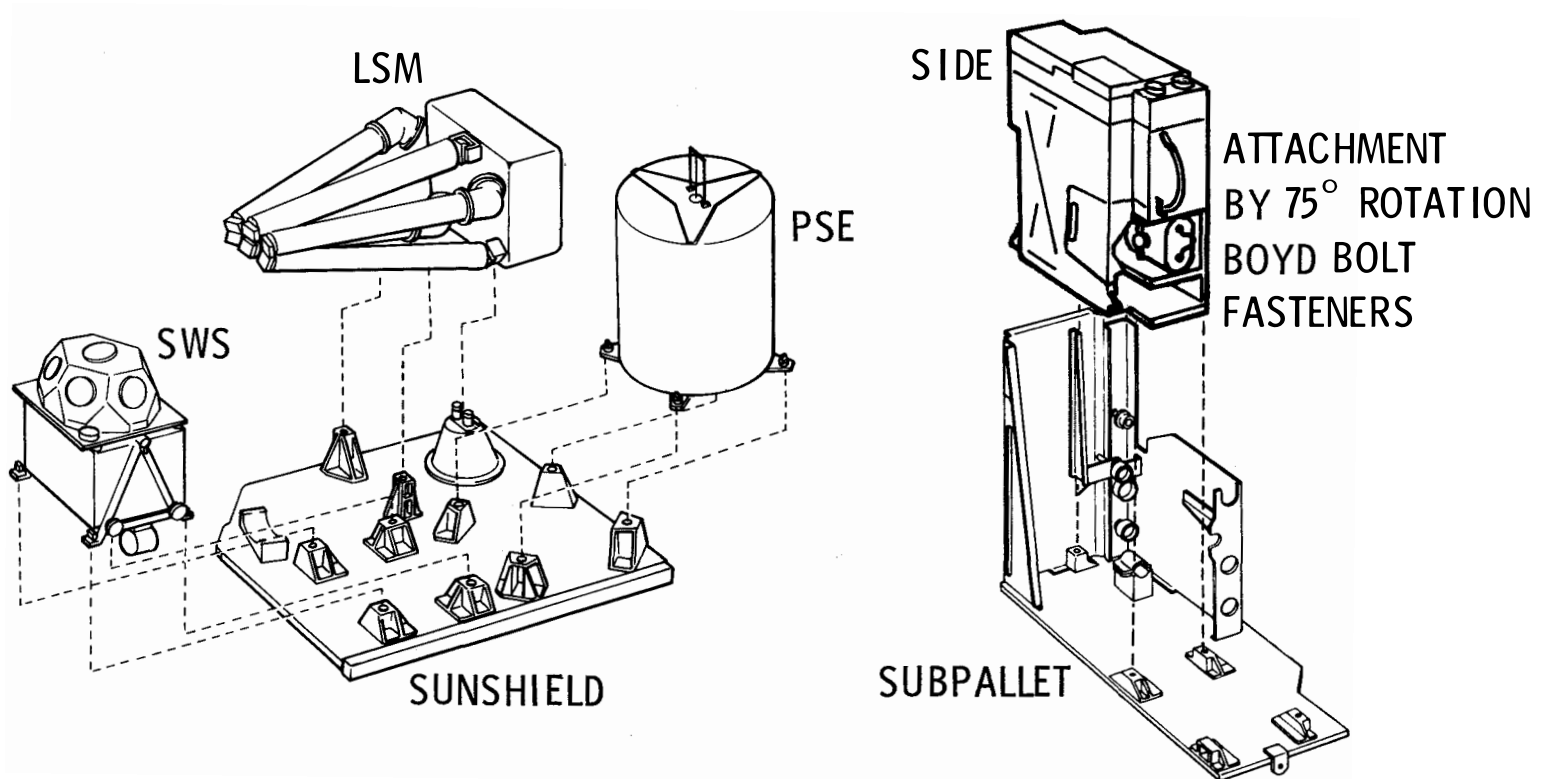

APR 69 5178.3.10

SPECIAL TOOLS

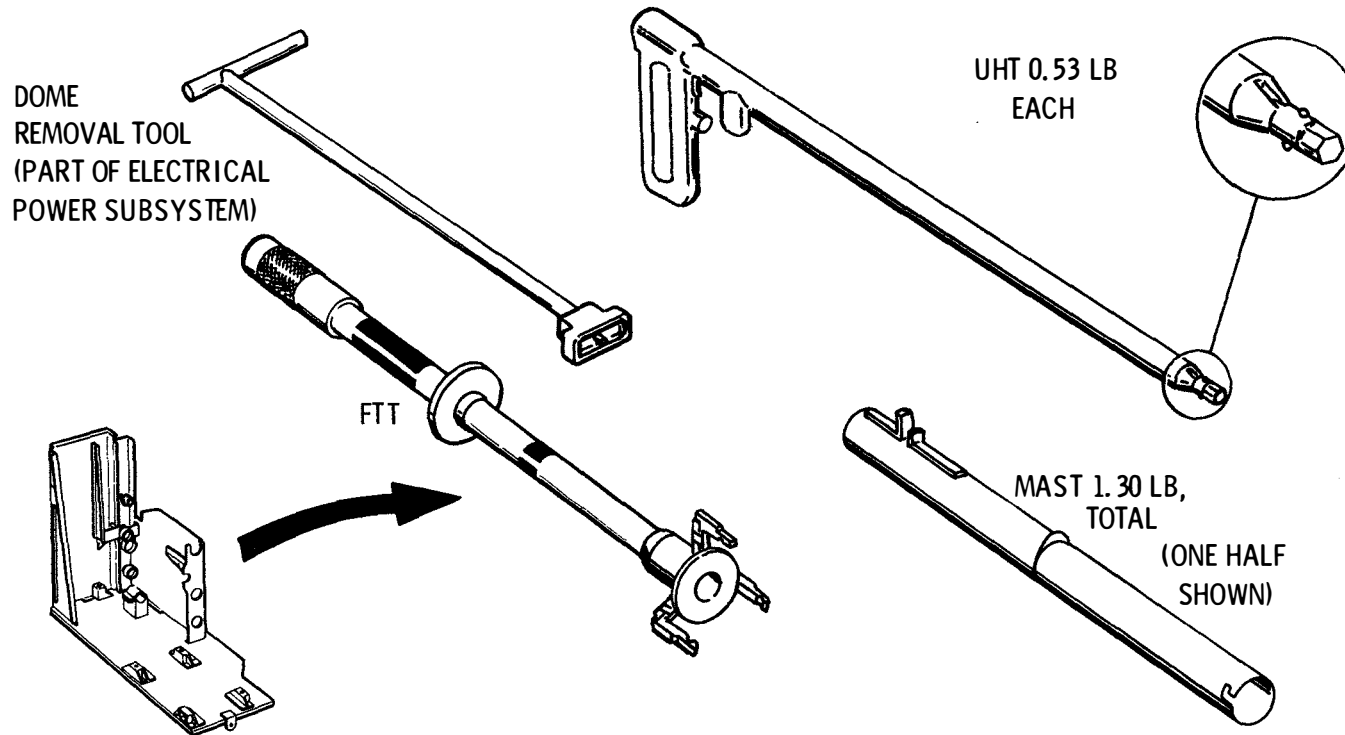

ALL WEIGHTS ARE EARTH LB

14.6 LB FUEL CASK MOUNT & INSULATION, PART OF STRUCTURE/THERMAL SUBSYSTEM, COVERED UNDER ELECTRICAL POWER SUBSYSTEM

APR 69 5178.3.11

STRUCTURE/THERMAL TELEMETRY

CODE AT, AX, ETC.,
INDICATES DATA VIA
ALSEP ANALOG MULTIPLEXER
(READ OUT ONCE PER 54 SEC)

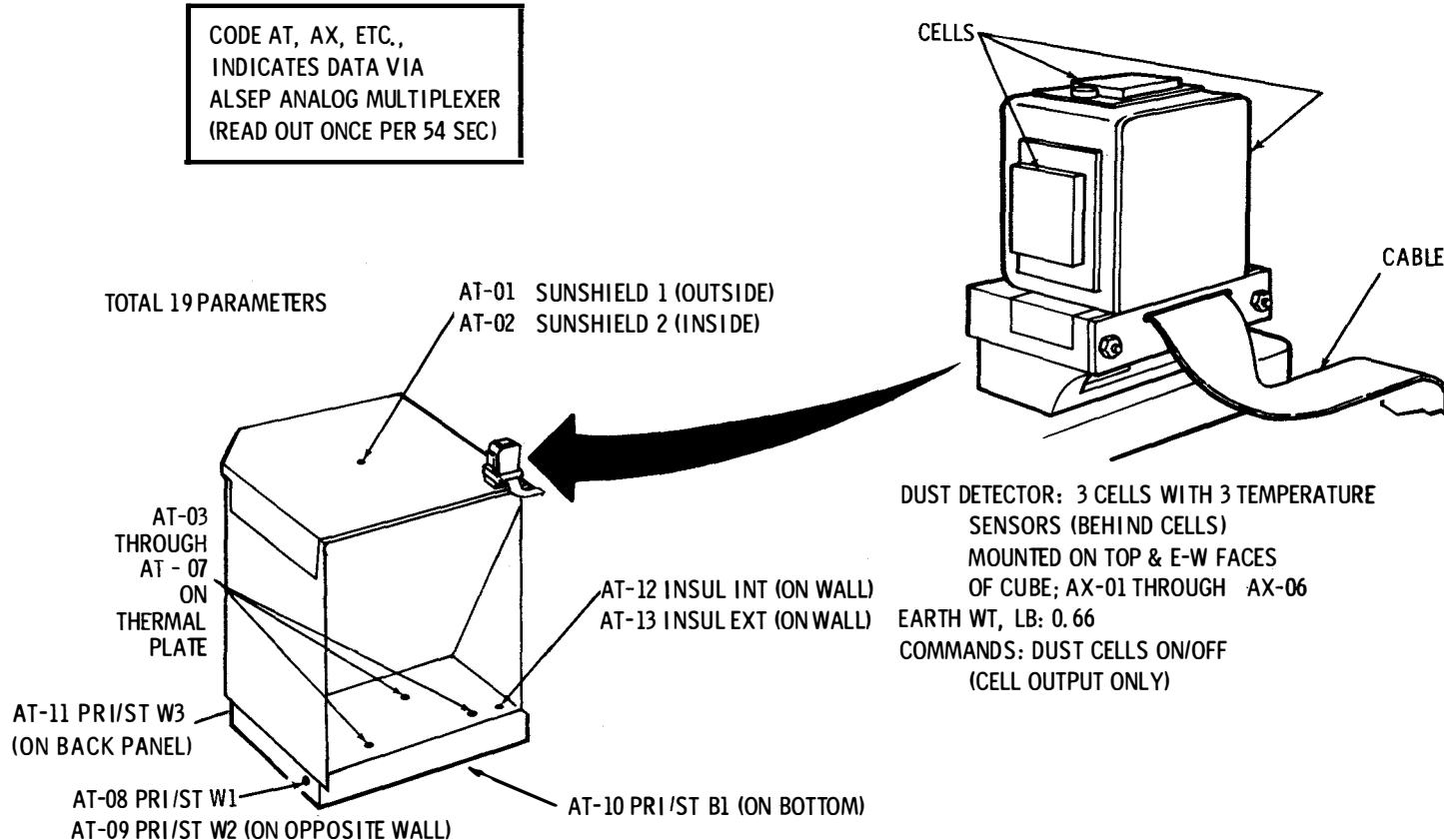

OCT 68 5178.3.12

ELECTRONICS COMPARTMENT

- THERMAL PLATE TEMP SENSORS (TM)
- Ⓣ DSS HEATER THERMOSTATS
- ▭ DSS & BACKUP HTR ELEMENTS

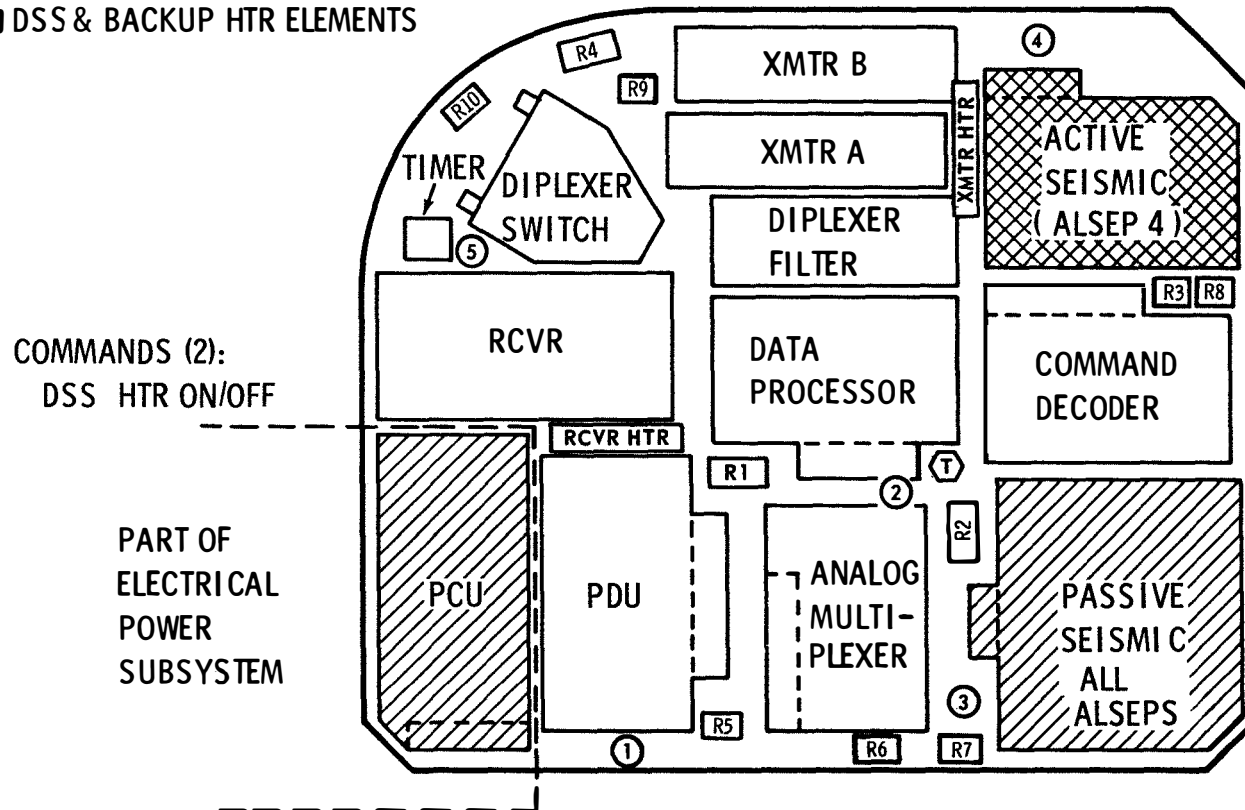

OCT 68 5178.3.13

ANTENNA AND AIMING MECHANISM

PHYSICAL PARAMETERS

MODIFIED AXIAL HELIX

23 IN. LONG x 1.5 IN. DIAM, 15° PITCH

5 IN. GROUND PLANE WITH 2 IN.

CYLINDRICAL SKIRT

EARTH WT, LB: 1.28 INC CABLE

PERFORMANCE

RIGHT HAND CIRC. POLARIZED

GAIN ON BORESIGHT, db	XMTR	RCV
	15.2	14.7
GAIN AT $\pm 27^\circ$, db	11.5	11.0

ANTENNA

AIMING MECHANISM

PHYSICAL PARAMETERS

SIZE, IN: 10.8 x 6.0 x 4.7

EARTH WT, LB: 2.00

(INC IN STRUCTURE/THERMAL)

DEPLOYMENT OPERATIONS

SET COARSE & FINE ELEV	} TABLE PLUS
SET COARSE & FINE AZ	
LEVEL, ALIGN SHADOW, RECHECK LEVEL	
APPROX TIME, 9 MIN	

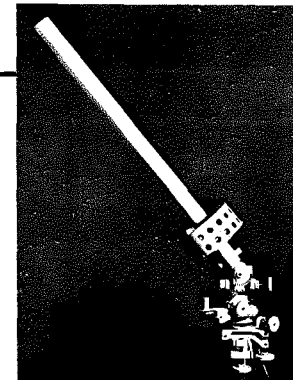

KEY FEATURES

RANGE OF ADJUSTMENT: AZIMUTH $\pm 90^\circ$, ELEVATION $\pm 50^\circ$ WRT VERTICAL, LEVEL $\pm 6^\circ$,
SUN $\pm 15^\circ$ WRT MAST

MAX. ERRORS : 0.99°, DUE TO MFG, MOUNTING, THERMAL DISTORTION, & BACKLASH

DATA SUBSYSTEM CHARACTERISTICS

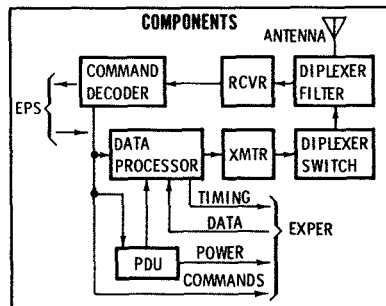

PHYSICAL PARAMETERS

	SIZE, IN.	EARTH WT, LB	POWER, W
DIPLEXER FILTER	6.88 x 2.5 x 2.5	0.90	-
RECEIVER	8 x 4 x 1.75*	1.84	1.32 MAX
DECODER	6.25 x 3.94 x 2.8*	2.70	1.40 MAX
DIPLEXER SWITCH	4.5 x 4 x 1.3	1.28	0.15**
TRANSMITTERS (2)	7.5 x 2.0 x 1.5 (ea)	1.13 (ea)	9.50 MAX (ea)
DATA PROCESSOR (A)	5.9 x 4.2 x 2.62	2.20	1.44
DATA PROCESSOR (O)	6.25 x 3.94 x 2.8*	3.03	0.50
PDU	7.25 x 4.0 x 2.8	2.36	1.75
* NOT INC CONNECTOR	TOTAL	16.57	15.91
** FOR XMTR "Y"		(NOT INC ANTENNA)	

COMMUNICATIONS

COMMANDS:

- 12 FOR EXPR PWR OPER/STBY/OFF
- 13 SPECIAL CMDs FOR:
 - BIT RATE (3)
 - DSS PROC SEL (2)
 - XMTR SEL (2)
 - XMTR ON/OFF (2)
 - TIMER OUT ACPT/INHIB (2)

DATA:

- 24 ANALOG ENG PARAMETERS
- 2 ANALOG SIGNALS FOR PDU SWITCHES (EXPR STBY)
- SAMPLED ONCE EVERY 54-SEC ALSEP SEQUENCE
- ADDITIONAL WORD IN DATA FORMAT PROVIDED FOR "CMD AS RCVD" & "CMD MAP"

DISPLAY: ANALOG CHARTS OR TABULAR PRINT /TV PLUS EVENT LIGHTS

KEY FEATURES

MODULATION: UPLINK, 1 & 2 KHz BI-PHASE
DOWNLINK, PCM SPLIT-PHASE

REDUNDANCY:

COMPONENT	REUNDANCY	SELECTION
RCVR	AT CIRCUIT LEVEL	
CMD DECODERS	ESSENTIALLY DUAL ("A" & "B") WITH INDIVIDUAL ADDRESSES	
DATA PROCESSORS	ESSENTIALLY DUAL ("X" & "Y")	SELECTED BY CMD*
XMTR	COMPLETE DUAL ("A" & "B") WITH ONE IN STBY	SELECTED BY CMD*

* EITHER PROCESSOR CAN BE USED WITH EITHER XMTR

- **THERMAL INTEGRITY:** IF XMTR OR RCVR SWITCH OFF, EQUIVALENT HEATERS AUTOMATICALLY SWITCH ON
- **TIMER:** 2-YR TIMER ALSO SUPPLIES DELAYED (PROGRAMMED) COMMANDS TO ALLOW LIMITED OPERATIONAL CAPABILITY IN CASE OF UPLINK (RCVR, ETC.) MALFUNCTION
- **ASTRONAUT SWITCHES** PROVIDE BACKUP CAPABILITY TO TURN ALSEP ON IN CASE OF UPLINK MALFUNCTION

PERFORMANCE

XMTR: 1 W MIN, DIFFERENT FREQUENCIES FOR EACH ALSEP
STABILITY, LONG-TERM: $\pm 0.0025\%$ /YEAR
SHORT-TERM: 2×10^{-10} PARTS/SEC

RCVR: 2119 MHz $\pm 0.001\%$

CMD DECODER: 100 DIFFERENT CMDs, UNIQUE ADDRESSES FOR EACH ALSEP

DATA PROCESSOR: NORMAL BIT RATE (NBR), 1.06 KBPS
LBR, 0.53 KBPS

HBR (ACTIVE SEISMIC), 10.6 KBPS FORMATTED BY ASE
NORMAL & LOW FRAME, 64 TEN-BIT WORDS (MSB FIRST)
ADC, 8 BITS PARALLEL OUT (0 TO 5V IN.), $\pm 0.3\%$ ACCURACY

PDU: INCLUDES ANALOG SIGNAL CONDITIONERS

APR 69 5178.3.15

ELECTRICAL POWER SUBSYSTEM

- RADIOISOTOPE THERMOELECTRIC GENERATOR (RTG)
- POWER MANAGEMENT REQUIREMENTS
- POWER CONDITIONING UNIT (PCU)
- POWER DISSIPATION RESISTORS (PDR)
- CIRCUIT & SYSTEM PROTECTION
- FUEL CASK & MOUNTING
- RTG/ASTRONAUT INTERFACE

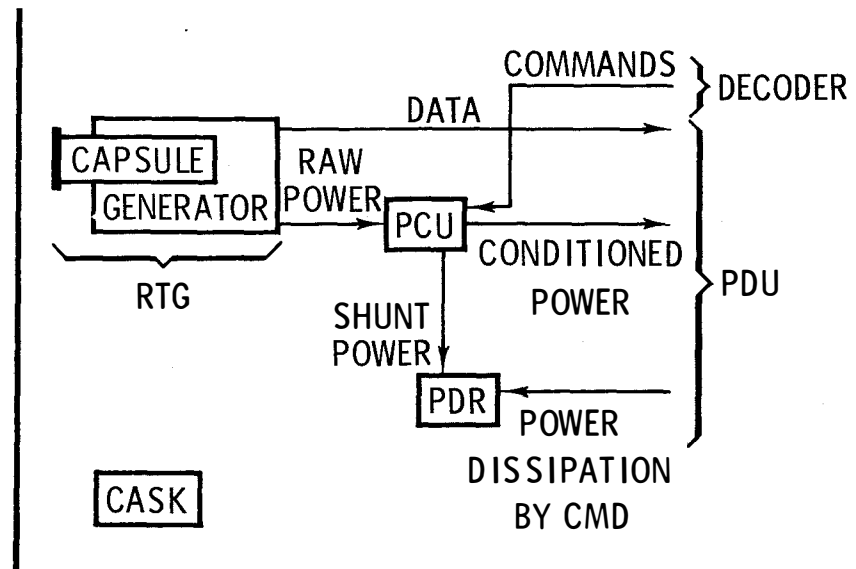

RTG CUTAWAY

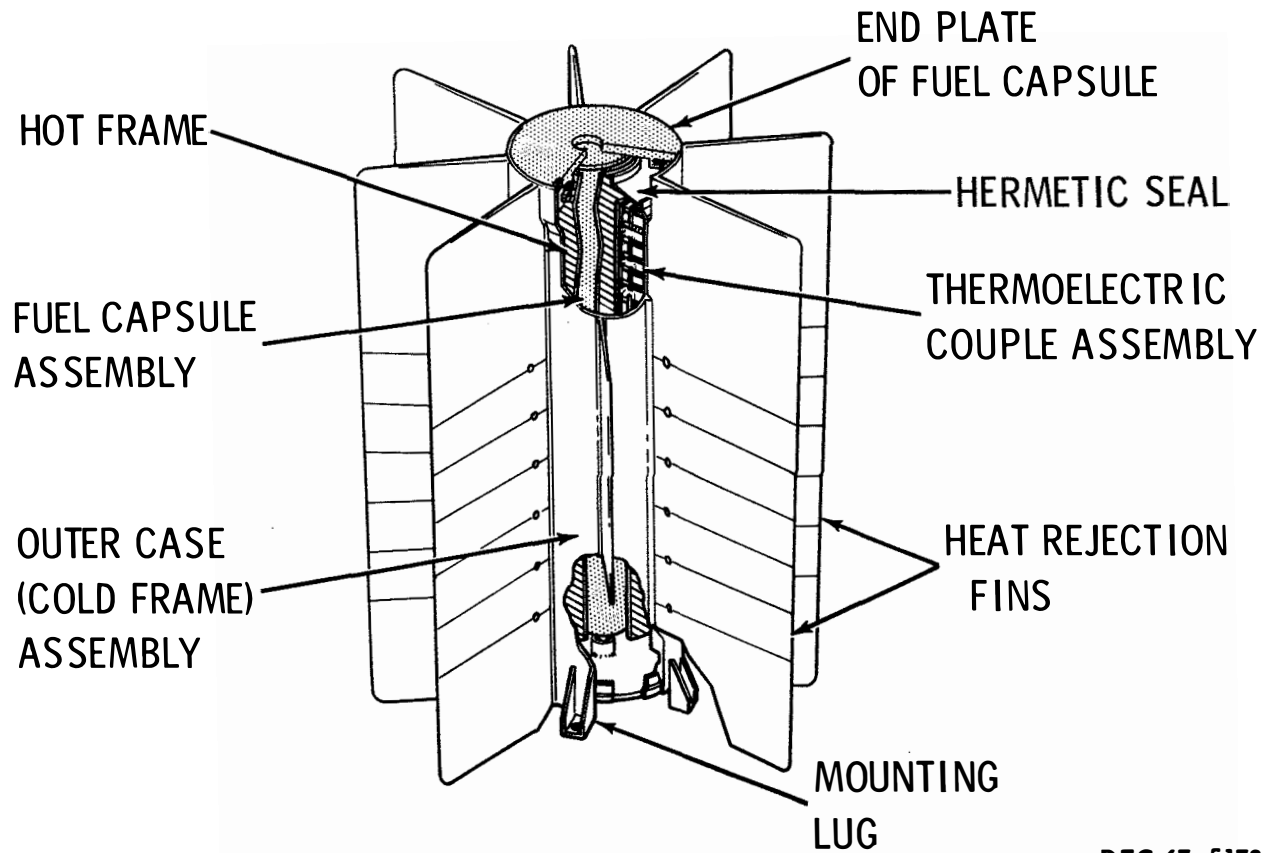

DEC 67 5178.3.17

RADIOISOTOPE THERMOELECTRIC GENERATOR

KEY FEATURES

FUEL: PU 238, 90- YR HALF LIFE, GENERATOR OUTPUT MAY DECREASE WITH TIME DUE TO DECREASED THERMOELECTRIC PERF

THERMOELECTRIC: LEAD TELLURIDE, PREVIOUSLY USED AT 900°- 950° F HOT JUNCTION, TESTED TO 1250° F, MELTS AT 1600° F

ATMOSPHERE: ≈25 PSIA ARGON AT OPER TEMP (< 15 PSIA AT ROOM TEMP); LEAD TELLURIDE OXIDIZES IN AIR & SUBLIMES IN HARD VACUUM

RE-ENTRY CRITERION: INTACT; FACTOR IN CASK DESIGN

PHYSICAL PARAMETERS

	SIZE, IN.	EARTH WT, LB
GENERATOR	16 DIAM x 18 HIGH	28.00
CAPSULE	2.6 DIAM x 17 HIGH	14.75

* NOT INC END PLATE

PERFORMANCE

OUTPUT POWER: 56.2W (ONE YR) & UP TO 74 W
 OUTPUT VOLTAGE: 16 VDC (NOMINAL)
 CURRENT: 4 AMP (APPROX)
 OVERALL EFFICIENCY: 4% (APPROX)
 HOT JUNCTION TEMP: 1100° F MAX *
 COLD JUNCTION TEMP: 600° F MAX *
 FUEL CAPSULE THERMAL OUTPUT: 1430 TO 1520 W
 FUEL CLAD TEMP : 1390° F MAX
 * LUNAR DAY (NIGHT PERF NEARLY SAME)

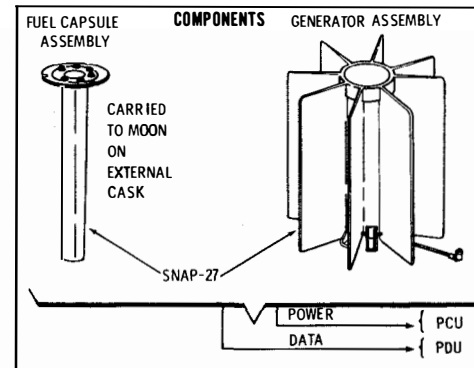

COMMUNICATIONS

COMMANDS: NO RTG CMDs

DATA:
 6 ANALOG PARAMETERS (TEMPS)
 EACH SAMPLED ONCE EVERY
 54-SEC ALSEP SEQUENCE

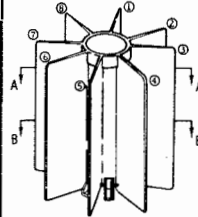

DISPLAY: ANALOG CHARTS,
 METERS, PRINTER,
 OR TV

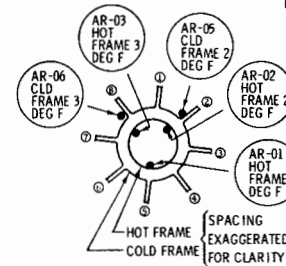

NOTE: AR-05 IS ACTUALLY ON FIN, NEAR COLD FRAME

SECTION A-A
 (≈13 IN. FROM BOTTOM)

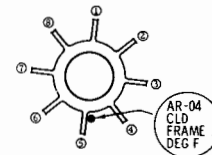

SECTION B-B
 (≈6 IN. FROM BOTTOM)

OCT 68 5178.3.18

RTG WARM-UP CYCLE

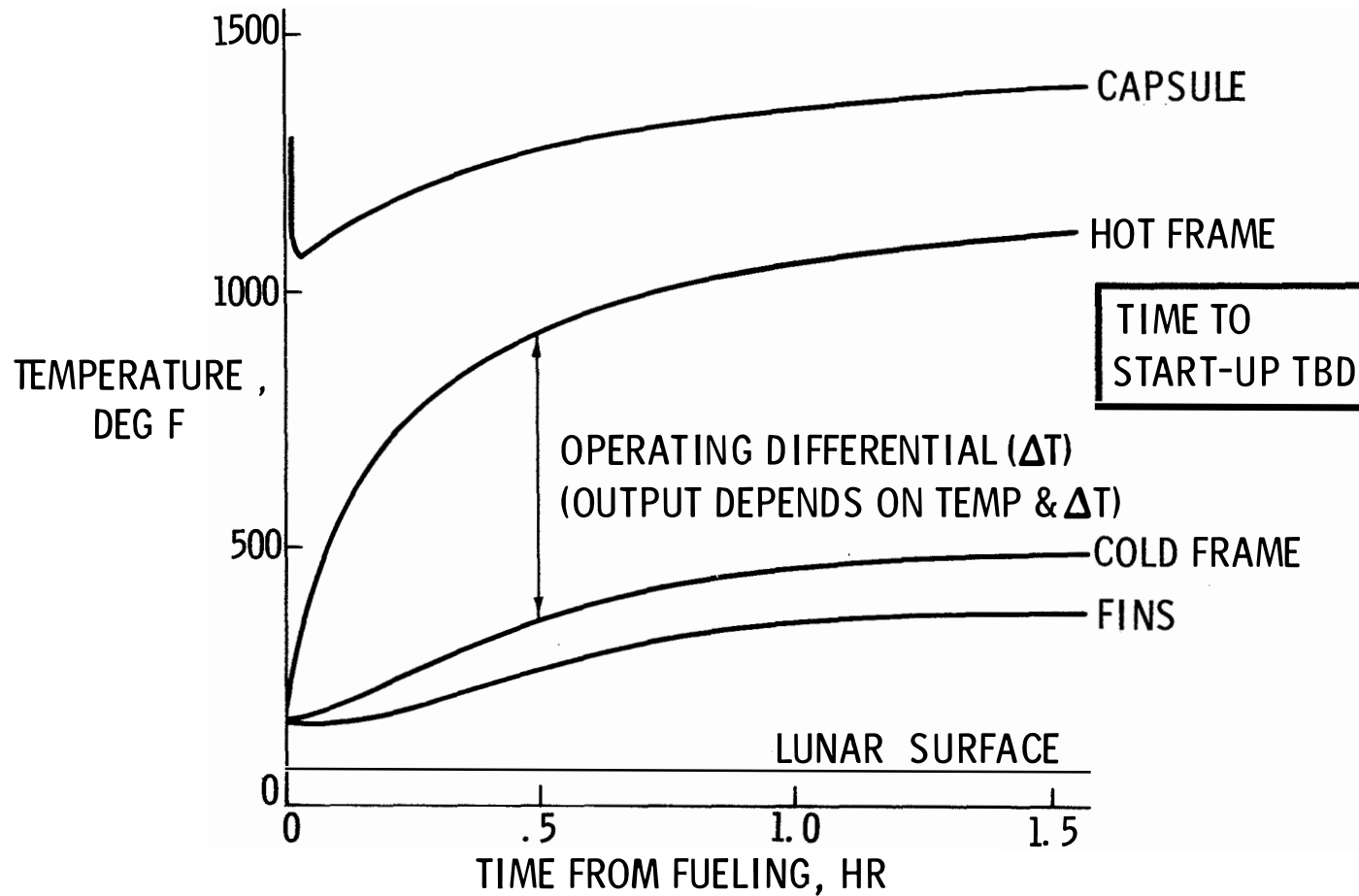

POWER MANAGEMENT REQUIREMENTS

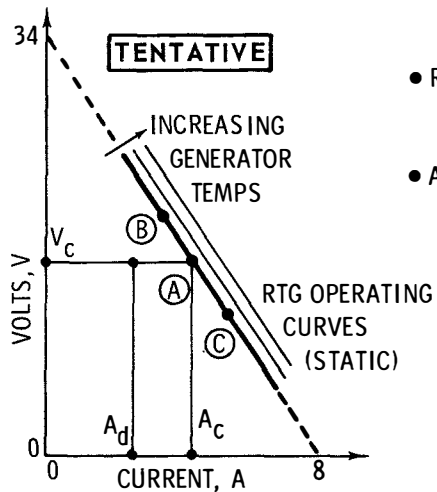

- RTG NOT LIKE SOLAR CELL/FUEL CELL/BATTERY SYSTEMS
 - STEEP CURVE OF V VS. A
 - NO SOURCE OR SINK (ALL POWER USED WHEN GENERATED)
- ALSEP USES LOAD ADJUSTMENT PCU TO MINIMIZE EMI
 - MONITORS PCU INPUT VOLTAGE, PROPORTIONAL TO RTG OUTPUT VOLTAGE (A, B, C)
 - ADDS VARIABLE LOAD TO DEMAND LOAD, A_d , BRINGING CURRENT UP TO "CONTROL" VALUE, A_c , THUS MAINTAINING "CONTROL" VOLTAGE, V_c

CONDITION	REQUIREMENT	RESOLUTION
NON-OPERATING	SHORT-CIRCUIT, TO KEEP THERMOELECTRIC COOL	RTG CABLE HAS SHORTING PLUG (WITH AMMETER) & SWITCH FOR TURN-ON AFTER CONNECTION
INITIALIZATION	DIGITAL ELECTRONICS NEED FAST RISE TO A STABLE CONDITION	PCU SENSES WHEN OUTPUT REACHES ACCEPTABLE LEVEL WITH RESISTIVE LOAD (B) & THEN STARTS OSCILLATOR TO SUPPLY ALL USERS (A)
OPERATIONAL CONTINGENCIES	SYSTEM MUST PRECLUDE OVERLOADS AND UNDERLOADS AT RTG INTERFACE	PCU PROVIDES WIDE RANGE (≈ 40 W) OF SHUNT REGULATION; CIRCUIT BREAKERS, RIPPLE-OFF, & GROUND COMMAND POWER MANAGEMENT PROCEDURES (SWITCHABLE LOADS)

APR 69 5178.3.20

POWER CONDITIONING UNIT

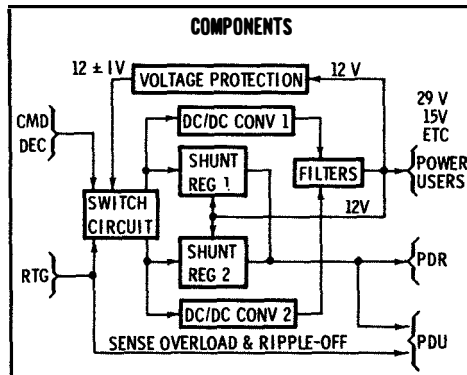

PERFORMANCE

OUTPUT VOLTS	NOMINAL LOAD, AMP	REGULATION:
+29	1.19	± 1% ON ALL
+15	0.08	OUTPUTS
+12	0.30	(REGULATOR OPERATES FROM + 12V OUTPUT)
+5	0.90	
-6	0.05	
-12	0.15	

PHYSICAL PARAMETERS

SIZE, IN.: 8.4 x 4.2 x 2.8

EARTH WT, LB: 4.6

POWER: DISSIPATION INSIDE PCU IS A FUNCTION OF OVERALL DISSIPATION TO MAINTAIN RTG OUTPUT VOLTAGE. AVERAGE 25% INSIDE & 75% IN PDR

COMMUNICATIONS

COMMANDS:

- 2 BASIC (PCU 1 SEL & PCU 2 SEL)
- 4 OTHERS (APPLY OR REMOVE 2 EXTERNAL LOADS IN PDR)

DATA:

- 8 ANALOG ENG PARAMETERS:
 - PCU INPUT (RTG OUTPUT) VOLTS & AMPS (2)
 - SHUNT REGULATOR CURRENTS (2)
 - PCU TEMPS (4)
- 6 OUTPUT VOLTAGES IN PDU
- SAMPLED ONCE PER 54-SEC ALSEP SEQUENCE

DISPLAY: ANALOG CHART, METERS OR PRINTER/TV

KEY FEATURES

PCU IS "FIXED-RATIO" CONVERTER; THUS, REGULATION OF 12V LINE REGULATES ALL LINES & MAINTAINS RTG OUTPUT FIXED

PCU PROTECTS RTG (EXAMPLE, AGAINST OPEN CIRCUITS)

PCU REGULATES BY LOAD ADJUSTMENT OVER 40W SWING BUT ADDITIONAL EXTERNAL LOADS (PDR) CAN BE SWITCHED ON/OFF BY COMMAND; MAY BE DICTATED BY CENTRAL STATION THERMAL BALANCE

PARTIAL REDUNDANCY WITH COMMAND SELECTION (PCU 1 OR PCU 2) PLUS AUTOMATIC SWITCHOVER FROM 1 TO 2 VIA OUT-OF-TOLERANCE SENSOR (VOLTAGE PROTECTION). NO SWITCHBACK, NORMALLY OPERATE WITH PCU 1

CAPACITANCES MAINTAIN VOLTAGES DURING SWITCHOVER

POWER DISSIPATION RESISTORS

- PART OF POWER MANAGEMENT PROVISIONS
- MOUNTED EXTERNAL TO CENTRAL ELECTRONICS
- TOGETHER WITH EXPERIMENT STANDBY RESISTORS, PROVIDE INITIAL RTG LOADS DURING LUNAR START - UP
- CHARACTERISTICS:

<u>ID</u>	<u>NUMBER OF RESISTORS</u>	<u>RATING, OHMS</u>	<u>FUNCTION</u>
(1, 2, 3)	3 IN PARALLEL	20 (EACH)	PCU 1 SHUNT
(4, 5, 6)	3 IN PARALLEL	20 (EACH)	PCU 2 SHUNT
(8)	1	121	DISSIP R1
(7)	1	64.9	DISSIP R2
	<u>8 TOTAL</u>		

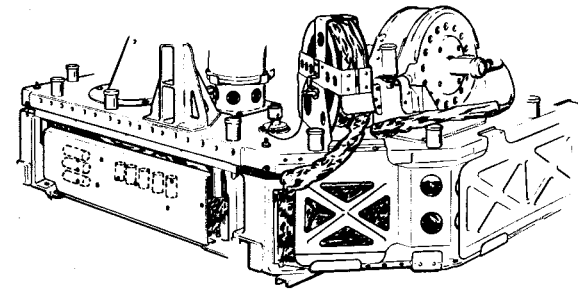

CIRCUIT AND SYSTEM PROTECTION

PHILOSOPHY: PROTECT ALSEP SYSTEM AT THE EXPENSE
OF INDIVIDUAL EXPERIMENTS, IF NECESSARY.

ACCOMPLISHED
MAINLY BY PDU

MINOR OVERLOADS

- ACCEPTED UNTIL TOTAL EXCEEDS AVAILABLE POWER AS SENSED IN PCU SHUNT AMPS
- MARGINAL SIGNAL CAUSES AUTOMATIC RIPPLE-OFF (SEQUENTIAL) OF EXPER 4, 3 & 1 (SIDE, SWS & PSE IN ALSEP 1). STOPS WHEN MARGIN IS OK
- RIPPLE - OFF SWITCHES FROM OPER TO STBY

MAJOR OVERLOADS

- CIRCUIT BREAKERS 0.50 ± 0.05 AMP IN EXPER OPER (29V) LINES SWITCH TO STBY
- CIRCUIT BREAKERS 0.70 ± 0.14 AMP IN 29V LINE OF XMTR & 0.110 to 0.225 AMP IN 12V LINES OF XMTR & RCVR
- WHEN XMTR OR RCVR GO OFF, EQUIVALENT HEATERS ARE SWITCHED ON
- FUSES 0.50 AMP IN EXPER STBY (HEATER) 29V LINES & 0.25 AMP IN DUST DETECTOR +12V & -12V LINES

RESET: TIMER AUTOMATICALLY ATTEMPTS RESET OF
RCVR & EXPER 4 EVERY 12 HRS (EXPER 4 IS
CONTINGENCY PROVISION FOR NG UPLINK)
OTHER EXPER & XMTR RESET BY COMMAND ONLY

DEMAND ANALYSIS: OPERATIONAL POWER MANAGEMENT
INCLUDES MONITORING POWER RESERVE (PCU
SHUNT AMPS) VIA TM & SWITCHING PDR ON/OFF

UNDERLOAD: IF PCU 1 CANNOT ADD ENOUGH LOAD,
SWITCHOVER TO PCU 2 OCCURS

FUEL CASK AND MOUNTING

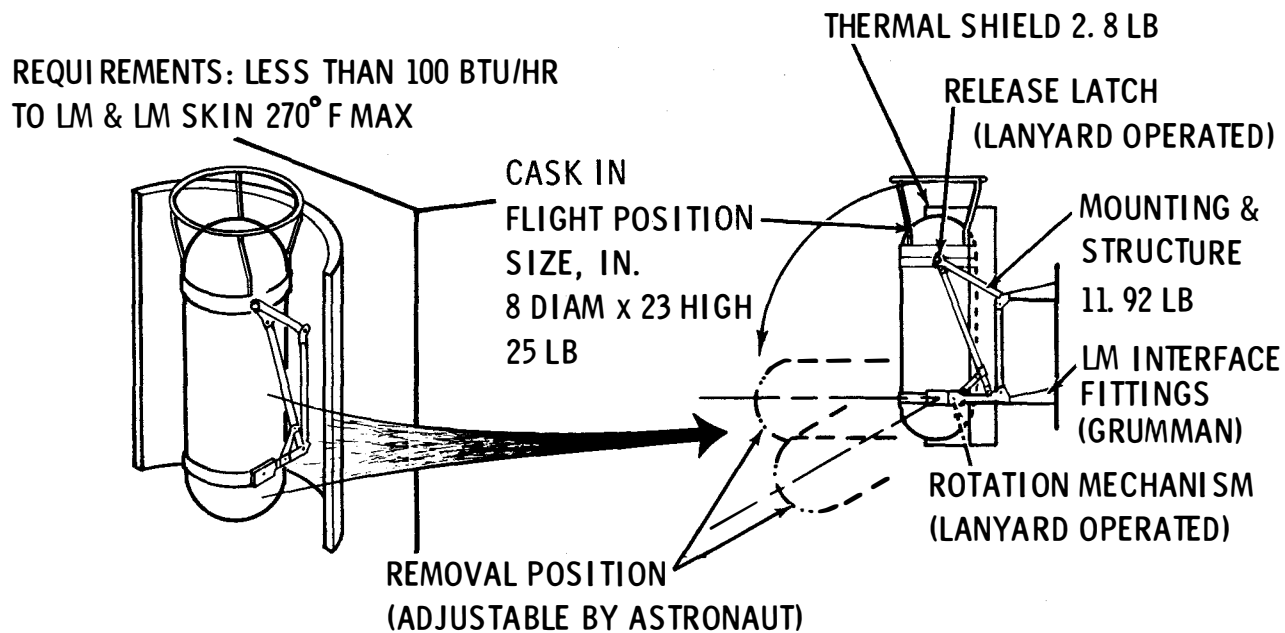

SUMMARY OF EARTH WT

POWER SUBSYSTEM	STRUCTURE/THERMAL SUBSYSTEM	
CASK	THERMAL SHIELD	2.80 LB
NOT INC	MTG & STRUCTURE	11.92
15.0 LB FUEL CAPSULE	MISC (ASTRO PROTECT)	5.28
	TOTAL	20.0 LB

OPERATIONS

RELEASE LATCHES AND DOME LOCK, ROTATE CASK,
UNSCREW CASK DOME (DOME REMOVAL TOOL),
TRANSFER FUEL CAPSULE (FUEL TRANSFER TOOL)
APPROX TIME 3 MIN, INC IN PRE-TRAVERSE TOTAL

APR 69 5178.3.24

RTG/ASTRONAUT INTERFACE

CONSTRAINT	RESOLUTION
THERMAL: • NO SUIT CONTACT WITH SURFACES MORE THAN 250°F • MINIMIZE HEAT LOAD ON SUIT COOLING EQUIP	<ul style="list-style-type: none"> • THERMAL BARRIER (SMALL DOOR) PROTECTION WHILE AT SEQ BAY • LANYARDS FOR CASK ROTATION & DOME LOCK • TOOL FOR DOME REMOVAL • TOOL FOR FUEL TRANSFER, CASK TO GENERATOR • SUBPACKAGE 2 CARRY PLACES RTG AWAY FROM SUIT
NUCLEAR: • NO HAZARDOUS DOSE	<ul style="list-style-type: none"> • PU 238 IS α EMITTER • α PARTICLES ARE ENTIRELY ABSORBED IN HEAT GENERATION • ONLY SECONDARY TYPES (γ & NEUTRONS) GET OUT • LOW EXTERNAL FIELD, VERY LOW DOSE LEVEL
ELECTRICAL: • NO EXPOSED CHARGED CONTACTS	<ul style="list-style-type: none"> • RTG CABLE HAS SHORTING SWITCH IN CONNECTOR • ASTRONAUT READS AMMETER, REMOVES DUST COVERS, ENGAGES CONNECTOR, & ACTIVATES SWITCH

OPERATIONS
PREPARE CASK FOR TRANSFER, 2 MIN; TRANSFER FUEL CAPSULE CASK TO GENERATOR, 1 MIN; DEPLOY SUBPACKAGE 2, UNREEL CABLE & MAKE CONNECTION, 2 MIN (ALL TIMES ARE APPROX)

APOLLO LUNAR HAND TOOLS

GEOLOGIC SAMPLING TOOLS

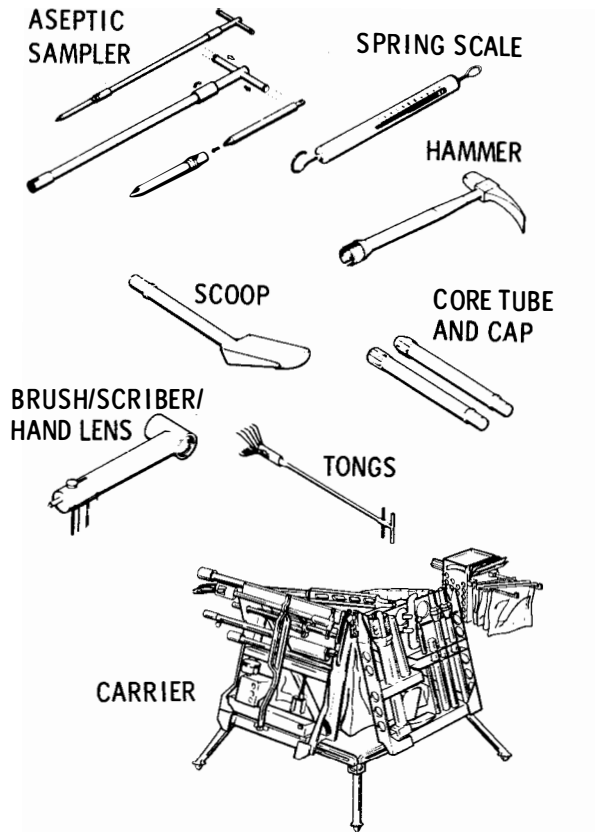

SURVEYING & PHOTOGRAPHIC INSTRUMENTS

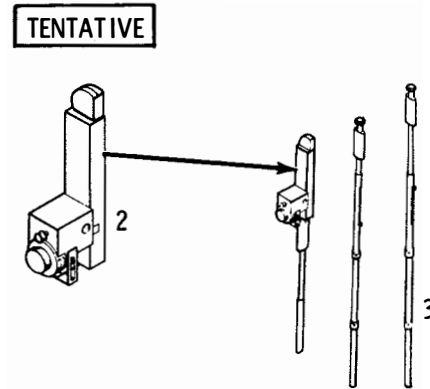

EARTH WT, 17.5 LB
 GEOLOGICAL TASKS WILL
 BE INDEPENDENT OF
 ALSEP DEPLOYMENT TASKS
 (NOT INC IN ALSEP TIME-LINE)

- 1 GNOMON
- 2 SURVEYING INSTRUMENT
- 3 INSTRUMENT STAFF

APR 69 5178.3.26

PASSIVE SEISMIC CHARACTERISTICS

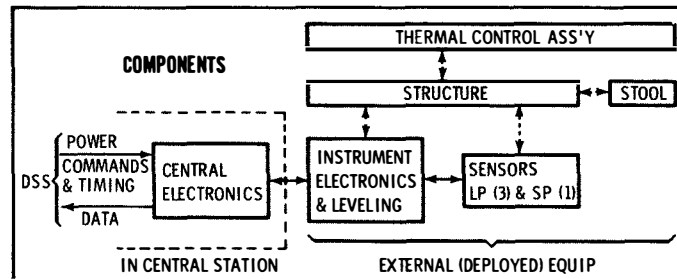

OPERATIONS	
<u>DEPLOYMENT</u>	<u>POST DEPLOYMENT</u>
<ul style="list-style-type: none"> LOCATE 10 FT FROM CENTRAL STATION PLACE STOOL SET INSTRUMENT ROUGH LEVEL $\pm 5^\circ$ ORIENT $\pm 20^\circ$ WRT SHADOW (SCIENTIFIC) UNFOLD SHROUD REPORT ALIGN $\pm 5^\circ$ WRT SHADOW APPROX TIME, 3 MIN	<ul style="list-style-type: none"> TURN ON (OPER) PRE-ASCENT UNCAGE (MAY BE PRE-ASCENT) FINE LEVEL CALIBRATE CHANGE GAINS RELEVEL AS NECESSARY CONTINGENCY CORRECTIVE ACTIONS

COMMUNICATIONS	
<u>COMMANDS:</u>	<u>DATA:</u>
<ul style="list-style-type: none"> POWER OPER/STBY/OFF 15 SPECIAL CMDs FOR: <ul style="list-style-type: none"> UNCAGE (1) AUTO & FORCED LEVEL (6) CALIBRATE (2) GAIN CHANGE (3) AUTO & FORCED THERMAL CONTROL (1) COARSE LEVELING SENSOR (1) FILTER BYPASS (1) BACKUP FROM TIMER TO UNCAGE & TO CALIBRATE SP 	<ul style="list-style-type: none"> 43 DIGITAL WORDS PER ALSEP FRAME 712 BPS (AVERAGE) 98% SCIENCE, 2% HK 1.2 SEC NORMAL REP RATE 8 ANALOG ENG PARAMETERS SAMPLED ONCE PER 54-SEC ALSEP SEQUENCE
<u>DISPLAY:</u>	
<ul style="list-style-type: none"> SPECIAL SEISMIC ANALOG CHART 8-CHANNEL ANALOG (INC 1 TEMP) EVENT LIGHTS OR PRINTER/TV 	

PHYSICAL PARAMETERS	
SIZE, IN.	{ INTERNAL 7.2 x 6.5 x 2.8 EXTERNAL 11.8 DIAM x 15.2 HIGH
EARTH WT, LB:	25 TOTAL
POWER, W:	7.5 (APPROX, MAX)

KEY FEATURES
EARTH CALIBRATION REQUIRES REMOVAL OF 1/6 OF LUNAR MASS
SENSORS CAGED BY PNEUMATIC RESTRAINT, RELEASED BY COMMAND (ARM/FIRE)
SENSORS MOUNTED ON GIMBAL & CAPABLE OF CORRECTING INITIAL $\pm 5^\circ$ ERROR BY LVL COMMANDS
INDIVIDUAL HEATERS FOR CENTRAL ELECTRONICS & INSTRUMENT, "THERMOSTATICALLY" CONTROLLED

APR 69 5178.3.27

PASSIVE SEISMIC SENSORS

LONG PERIOD:

TRIAxIAL SET OF PENDULUMS WITH NATURAL FREQUENCY OF 1/15 CPS
SENSITIVITY $10 \text{ m}\mu$ ($1 \text{ m}\mu$ GOAL) WITH 80 db DYNAMIC RANGE
CAPACITANCE - TYPE DISPLACEMENT TRANSDUCERS
COIL - MAGNET DAMPING

SHORT PERIOD:

SINGLE VERTICAL SEISMOMETER WITH FREE RESONANCE 1 TO 2 CPS
SENSITIVITY $10 \text{ m}\mu$ ($1 \text{ m}\mu$ GOAL) WITH 80 db DYNAMIC RANGE
COIL-MAGNET TRANSDUCER

TIDAL OUTPUT:

FEEDBACK FILTER ON LONG-PERIOD DATA
SENSITIVITY: 320μ GAL VERTICAL (8μ GAL GOAL)
0.4 ARC SEC TILT (0.01 ARC SEC GOAL)

MODES OF OPERATION:

INDEPENDENT GAIN CHANGE BY COMMAND ON LP HORIZ,
LP VERTICAL, & SP (0, -10, -20, -30 db)

BASIC DATA WORD:

10 - BIT WORD FOR EACH SENSOR READING

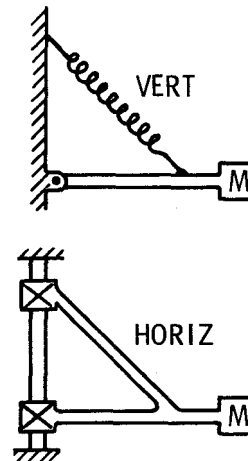

ACTIVE SEISMIC CHARACTERISTICS

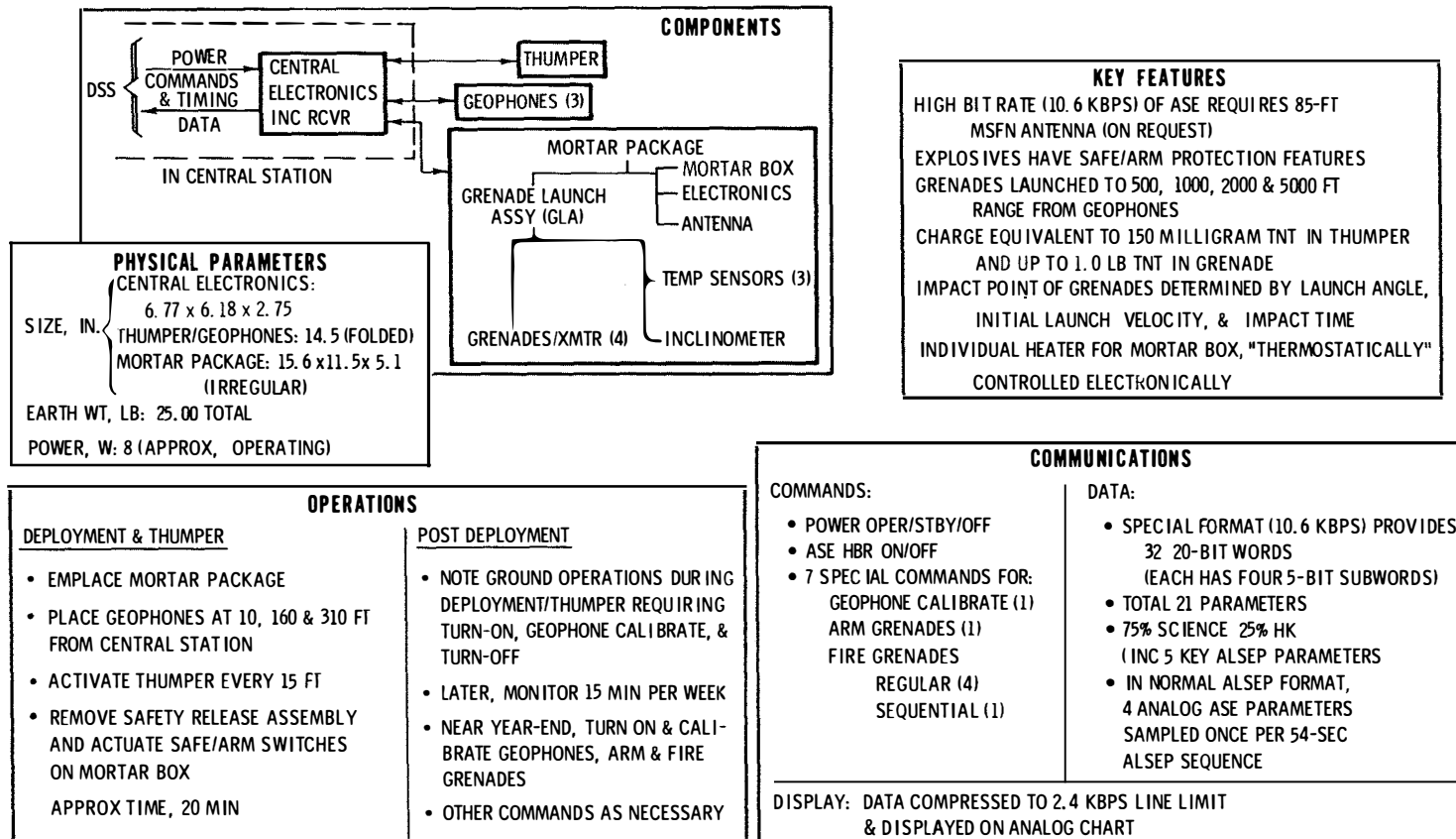

OCT 68 5178.3.29

ASE DETECTION SYSTEM

GEPHONE (SENSORS)

TYPE: ELECTROMAGNETIC

NATURAL FREQUENCY: 7.5 CPS

SENSITIVITY: 250 VOLT/METER/SEC

WEIGHT: 6 OZ EACH SENSOR

AMPLIFIER

3 CHANNELS EACH WITH PREAMP, FILTER AND LOG COMPRESSOR

80 DB DYNAMIC RANGE LOG COMPRESSED TO 40 DB

LOG COMPRESSOR TEMPERATURE CONTROLLED

GEPHONE & AMPLIFIER

SENSITIVITY: 5 $m\mu$ PEAK DISPLACEMENT AT 10 Hz (1 $m\mu$ GOAL)
AT A SIGNAL TO NOISE RATIO OF 18 db

BANDWIDTH: 3 TO 250 Hz WITH RESPECT TO VELOCITY

BASIC DATA WORD

5-BIT WORD FOR EACH SENSOR READING AT 500 SAMPLES/SEC
(EACH CHANNEL)

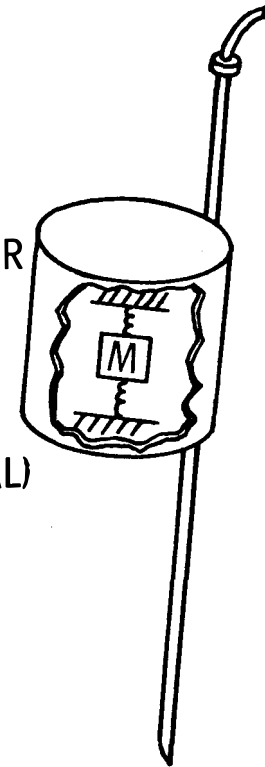

APR 69 5178.3.30

THUMPER CHARACTERISTICS

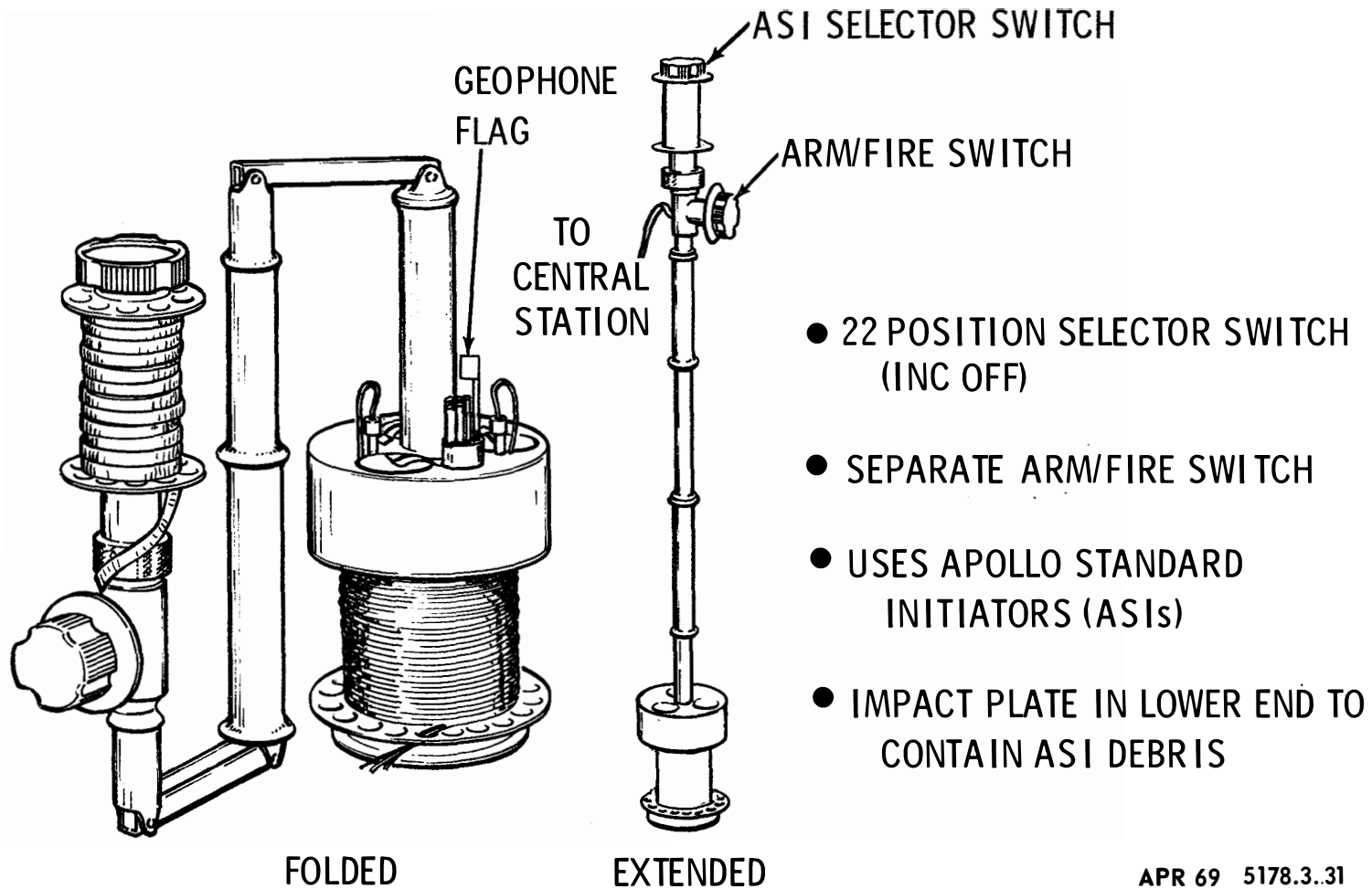

APR 69 5178.3.31

MAGNETOMETER CHARACTERISTICS

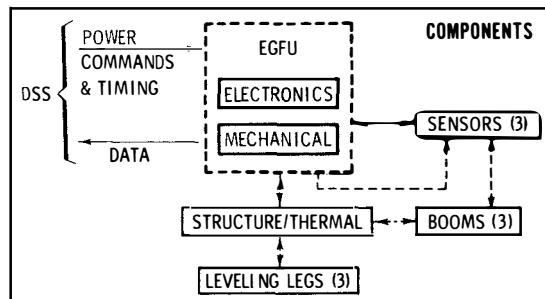

PHYSICAL PARAMETERS

SIZE, IN. (STOWED): 25 x 12 x 11 (IRREGULAR)

EARTH WT, LB: 19.4 W/O CABLE

POWER, W: 5.8 (DAY)
10.9 (NIGHT) } APPROX

OPERATIONS

DEPLOYMENT	POST DEPLOYMENT
<ul style="list-style-type: none"> LOCATE 50 FT FROM CENTRAL STATION (AWAY FROM LM) SET AND ADJUST LEVELING LEGS $\pm 3^\circ$ UNFOLD BOOMS ORIENT $+3^\circ$ WRT SHADOW (SCIENTIFIC AND THERMAL) REPORT ALIGN $+1^\circ$ 	<ul style="list-style-type: none"> TURN ON (OPER) PRE-ASCENT FLIP/CAL SITE SURVEY AFTER ASCENT CHANGE RANGE ADJUST OFFSET CONTINGENCY CORRECTIVE ACTIONS

APPROX TIME, 8 MIN

COMMUNICATIONS

COMMANDS:	DATA:
<ul style="list-style-type: none"> POWER OPER/OFF (NO STBY) 8 SPECIAL CMDS FOR: <ul style="list-style-type: none"> SITE SURVEY (1) FLIP/CAL (2) RANGE CHANGE (1) PERCENTAGE OFFSET (2) SELECT THERMAL CONTROL SENSOR (1) FILTER BYPASS (1) 	<ul style="list-style-type: none"> 7 DIGITAL WORDS PER ALSEP FRAME 116 BPS (AVERAGE) 86% SCIENCE, 14% HK 9.6 SEC REP RATE NO ANALOG OUTPUTS

DISPLAY: ANALOG CHARTS FOR SCIENCE
EVENT LIGHTS & PRINTER/TV FOR HK

KEY FEATURES

SENSOR CALIBRATION ON EARTH REQUIRES SPECIAL FLUX TANKS TO AVOID SENSOR SATURATION

FLIP/CAL CYCLE MUST BE PERFORMED EVERY 12 HR & EVERY 3° C TEMP CHANGE TO REMOVE DRIFTS (TEMP, ETC.) & AVOID PERMANENT OFFSET OF SENSOR

SITE SURVEY MODE ACTIVATED ONLY ONCE NEAR START OF MISSION (BETWEEN 4TH & 5TH FLIP/CAL ONLY)

CONTAMINATION LIMIT LESS THAN 0.25 GAMMA FROM ALL OTHER ALSEP EQUIP & LM DESCENT STAGE

DURING PRELAUNCH & FLIGHT, LESS THAN 1 GAUSS MAGNETIC EXPOSURE

"THERMOSTATICALLY" CONTROLLED HEATERS IN SENSOR HEADS. ELECTRONICS MUST OPERATE ESSENTIALLY CONTINUOUSLY

APR 69 5178.3.32

MAGNETOMETER SENSORS

SENSOR TYPE: FLUX GATE

FULL SCALE RANGE: ± 100 , ± 200 , ± 400 GAMMA (SELECTED BY

COMMAND); EARTH'S EQUATORIAL FIELD $\approx 35,000$ GAMMA (1 GAUSS = 10^5 GAMMA)

RESOLUTION: 0.2 % FULL SCALE

ACCURACY: 0.5 % FULL SCALE

FREQUENCY RESPONSE: APPROX 1.5 CPS

MODES OF OPERATION: MANY COMBINATIONS OF RANGE & OFFSET

NORMAL ORIENTATION: ORTHOGONAL

SITE SURVEY: SPECIAL MODE IN WHICH SENSORS ARE GIMBALLED

90° AND ROTATED SO THAT ALL THREE POINT SEQUENTIALLY

ALONG X, Y, & Z AXIS

BASIC DATA WORD: 10-BIT WORD FOR EACH SENSOR READING,

INCLUDING 9-BIT VALUE PLUS POLARITY (SIGN) BIT

SOLAR WIND SPECTROMETER CHARACTERISTICS

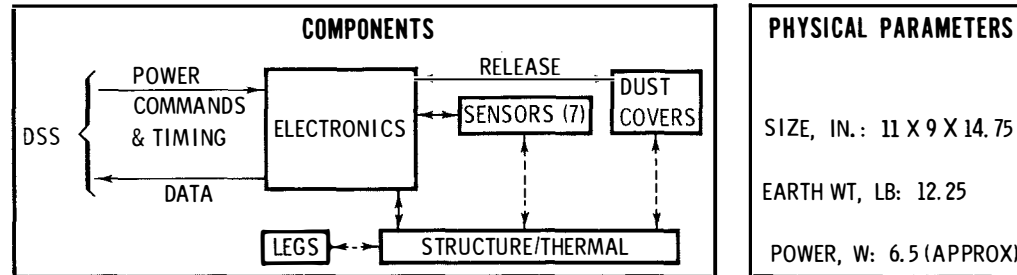

OPERATIONS

DEPLOYMENT

- LOCATE 13 FT FROM CENTRAL STATION (PREFERABLY N-S)
- EXTEND LEVELING LEGS
- LEVEL $+5^\circ$
- ORIENT $+5^\circ$ WRT SHADOW (SCIENTIFIC & THERMAL)

APPROX TIME, 1 MIN

POST DEPLOYMENT

- TURN ON (OPER) MAY BE PRE-ASCENT
- READ BASE LINE DATA
- AFTER ASCENT, REMOVE DUST COVERS
- HIGH GAIN MODE
NO OTHER COMMAND FUNCTIONS

COMMUNICATIONS

COMMANDS:

- POWER OPER/STBY/OFF
- 1 SPECIAL CMD FOR DUST COVER REMOVAL (ALSO USED TO OBTAIN HIGH GAIN MODE)

DISPLAY: PRINTER

DATA:

- 4 DIGITAL WORDS PER ALSEP FRAME
- 66 BPS (AVERAGE)
- 72% SCIENCE, 18% HK
- 449 SEC NORMAL REP RATE
- NO ANALOG OUTPUTS

KEY FEATURES

REQUIRES CLEAR HEMISPHERE OF SPACE, OBSTRUCTIONS SUCH AS CENTRAL STATION SHOULD BE LOCATED IN ZONE OF REDUCED SENSOR SENSITIVITY

"THERMOSTATICALLY" CONTROLLED HEATER

SWS SENSORS

MODES OF OPERATION: INTERNAL
PROGRAM STEPS SENSORS
THROUGH 21 LEVELS
(14 POS & 7 NEG)
BASIC DATA WORD: 8-BIT
WORD FOR EACH SENSOR
READING WITH TWO FLAG
BITS FOR ID

SENSOR TYPE: FARADAY CUPS (7)
FIELD OF VIEW: APPROX 57° EACH
RANGE: ELECTRONS 6 TO 1330 eV, POSITIVE IONS 18 TO 9980 eV
READ OUT AS CURRENTS FROM 10^{-12} TO 10^{-8} amps (LOGARITHMIC)
DIRECTIONALITY: BY
ANALYSIS OF DIFFERENT SENSORS
CAN DETERMINE FLUX DIRECTION $\pm 15^\circ$

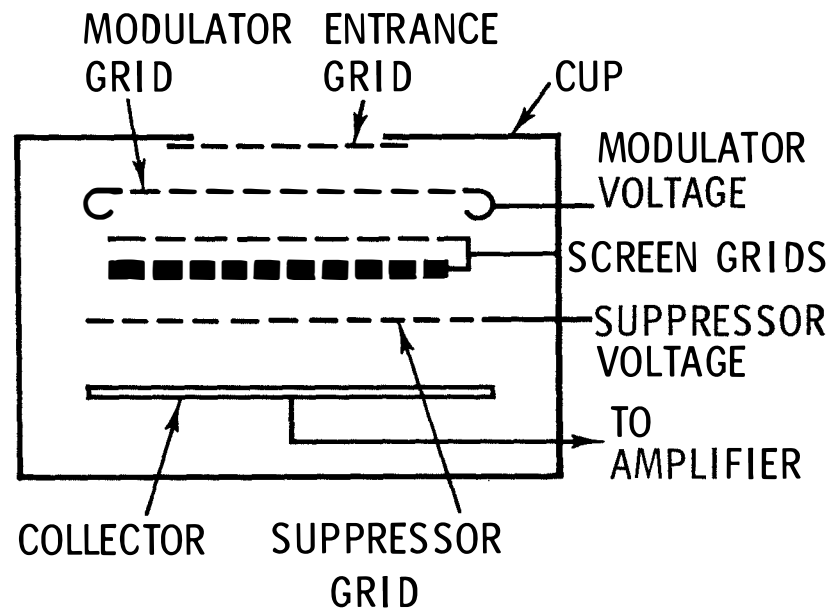

SUPRATHERMAL ION DETECTOR CHARACTERISTICS

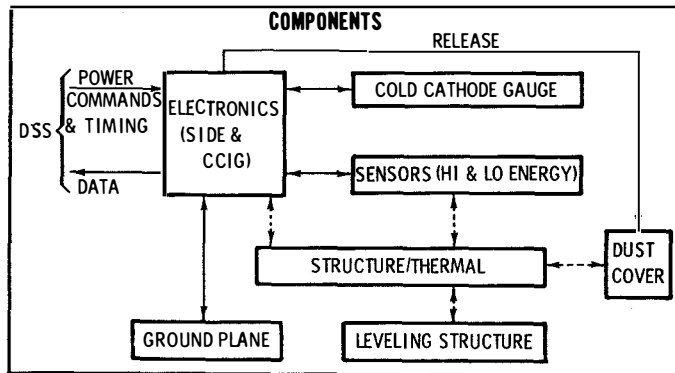

- KEY FEATURES**
- HIGH & LOW ENERGY SENSORS CANNOT OPERATE IN ATMOSPHERE (CALIBRATE IN VACUUM)
 - CCIG SEALED PRELAUNCH, SQUIB-ACTUATED RELEASE MECHANISM (SEAL BREAK COMMAND)
 - CCIG MAGNET SHIELDED TO AVOID INTERFERENCE WITH OTHER INSTRUMENTS
 - CONTAMINATION AT SIDE LOCATION MUST BE LESS THAN 0.01 GAUSS & 1 V/M (DC TO 10 Hz)
 - DETECTOR ORIENTATION AWAY FROM SUB-EARTH POINT, CCIG ORIFICE AWAY FROM ALSEP, LM & EARTH
 - "THERMOSTATICALLY" CONTROLLED HEATER IN DETECTOR PACKAGE

- OPERATIONS**
- | DEPLOYMENT | POST DEPLOYMENT |
|---|---|
| <ul style="list-style-type: none"> • LOCATE 55 FT FROM CENTRAL STATION (AWAY FROM LSM) • SET GROUND PLANE • REMOVE & PLACE (ORIENT) CCIG • LEVEL SIDE $\pm 5^\circ$ • ORIENT $\pm 5^\circ$ WRT SHADOW (SCIENTIFIC & THERMAL) | <ul style="list-style-type: none"> • TURN ON (OPER) SIDE POST-ASCENT • READ BASE LINE DATA • REMOVE DUST COVER, BREAK CCIG SEAL, READ DATA • CONTINGENCY CORRECTIVE ACTIONS (CHANGE SIDE MODES) |
- APPROX TIME, 4 MIN

- COMMUNICATIONS**
- | COMMANDS: | DATA: |
|--|--|
| <ul style="list-style-type: none"> • POWER OPER/STBY/OFF • 5 SPECIAL CMDS MULTIPLEXED (4 LOADS & 1 EXECUTE) • CMDS PERFORM: <ul style="list-style-type: none"> 2 ONE-TIME FUNCTIONS <ul style="list-style-type: none"> • REMOVE DUST COVER • BREAK SEAL 15 REPETITIVE FUNCTIONS <ul style="list-style-type: none"> • CALIBRATE (1) • CHANGE MODES (9) • TURN EQUIP ON/OFF (5) • BACKUP FROM TIMER FOR DUST COVER & SEAL BREAK AND PWR TURN ON EVERY 12 HRS (FLT NO. 1) | <ul style="list-style-type: none"> • 5 DIGITAL WORDS PER ALSEP FRAME 83 BPS (AVERAGE) 40% SCIENCE, 60% HK 155 SEC BASIC REP RATE 3711 SEC FULL CYCLE <p style="text-align: right;">} NORMAL</p> <ul style="list-style-type: none"> • 2 ANALOG CHANNELS OF SCIENCE DATA SAMPLED ONCE PER 54-SEC ALSEP SEQUENCE |
- PHYSICAL PARAMETERS**

SIZE, IN.: 15.3 X 13.0 X 4.5

EARTH WT, LB: 19.6

POWER, W: 6.0 (APPROX)
- DISPLAY: PRIMARILY PRINTER

JAN 69 5178.3.36

SIDE SENSORS

	ION DETECTOR		COLD CATHODE GAUGE
SENSOR TYPE	CURVED PLATE ANALYZER*		REDHEAD
FIELD OF VIEW	30° X 6°		NA
RANGE	POSITIVE IONS 10 TO 3500 ev	POSITIVE IONS 0.2 TO 48.6 ev**	10 ⁻⁶ TO 10 ⁻¹² TORR (10 ⁻¹³ GOAL)
DIRECTIONALITY	DETECTOR AXES 15° OFF VERTICAL REFERENCE (PARALLEL)		ORIFICE HORIZONTAL, PREFERABLY SOUTH
MODES OF OPERATION	PROGRAMMED STEPS, VARIABLE BY COMMAND. ALSO X10 INTE- GRATION FOR LOW FLUX LEVELS		THREE OVERLAPPING RANGES AUTOMATICAL- LY SELECTED BY IN- TERNAL LOGIC
BASIC SENSOR DATA WORD	2 10-BIT WORDS, EACH LIMITED TO 999 DECIMAL, HENCE MAX PARTICLE COUNT 999,999		8-BIT WORD FOR EACH SENSOR READING, MUL- TIPLEXED WITH SIDE HK
* VELOCITY SELECTOR (CROSSED ELECTRIC/MAGNETIC FIELDS) ON LOW ENERGY DETECTOR			
**1 TO 130 AMU PER UNIT CHARGE			

GROUND PLANE STEPS THROUGH 24 VOLTAGE LEVELS (11 POS, 11 NEG, & 2 ZEROS)
± 27.6V, MAX

APR 69 5178.3.37

HEAT FLOW CHARACTERISTICS

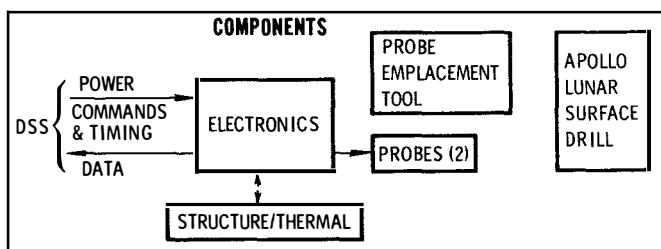

KEY FEATURES

SENSOR CALIBRATION ON EARTH REQUIRES SPECIAL FACILITY
 AVOID DISTURBING LUNAR SURFACE REFLECTIVE PROPERTIES AROUND PROBES
 REQUIRES RADIATIVE THERMAL COUPLING BETWEEN PROBE & HOLE PLUS
 NO THERMAL SHORT-CIRCUIT TO SURFACE
 THERMOSTATICALLY CONTROLLED HEATER IN ELECTRONICS PACKAGE

PHYSICAL PARAMETERS
 (NOT INC DRILL)

SIZE, IN: { ELECTRONICS 13 x 9 x 8
 PROBES 25.5 x 4.5 x 3.5
 (IN PACKAGE)

EARTH WT, LB: 9.7 LB (TOTAL)

POWER, W: 3.9 TO 10.6

OPERATIONS

DEPLOYMENT

- LOCATE ELECTRONICS 30 FT FROM CENTRAL STATION
- LEVEL $\pm 12^\circ$
- ALIGN $\pm 5^\circ$ WRT SHADOW (THERMAL)
- DRILL HOLES (2) 3 METERS DEEP & PLACE PROBES IN BOTTOM OF HOLES USING TOOL
- HOLES 30 FT APART & 16 FT FROM ELECTRONICS

APPROX TIME, 9 MIN, PLUS 30 MIN FOR DRILLING

POST DEPLOYMENT

- TURN ON (OPER) PRE-ASCENT
- READ GRADIENT DATA CONTINUOUSLY EXCEPT DURING CONDUCTIVITY TESTS
- MAKE CONDUCTIVITY TESTS -TIMES FOR UP TO 48 HRS EACH TIME

COMMUNICATIONS

COMMANDS:

- POWER OPER/STBY/OFF
- 10 SPECIAL CMDS FOR:
 - SELECT GRADIENT, HI CONDUCTIVITY, OR LO CONDUCTIVITY MODES (3)
 - SELECT MEASUREMENT SEQUENCE (6)
 - SELECT & ACTIVATE CONDUCTIVITY HTRS (1)

DATA:

- 1 DIGITAL WORD PER ALSEP FRAME (FOR 16 OUT OF EVERY 90 FRAMES) 3.0 BPS (APPROX) 65% SCIENCE, 35% HK 435 SEC REP RATE (FULL SEQUENCE)
- 6 ANALOG ENG PARAMETERS SAMPLED ONCE PER 54 SEC ALSEP SEQUENCE

DISPLAY: X-Y PLOTTER OR PRINT (REQUIRES DATA ANALYSIS)

HEAT FLOW SENSORS

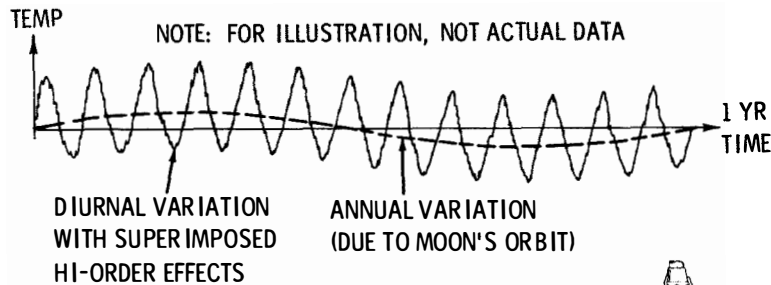

- PROBLEM: TO FIND THE SMALL DC COMPONENT IN A POSSIBLY LARGE AC WAVE

MODES OF OPERATION: MODE/G, MODE/LK, & MODE/HK PLUS MANY MEASUREMENT SEQUENCES

BASIC DATA WORD: 13-BIT OUTPUT OF ADC IN 2 ALSEP WORDS (PLUS ID)

TYPICAL BRIDGE READING (8 ALSEP WORDS)

}	(1) + EXCITATION
	(2) + OUTPUT
	(3) - EXCITATION
	(4) - OUTPUT

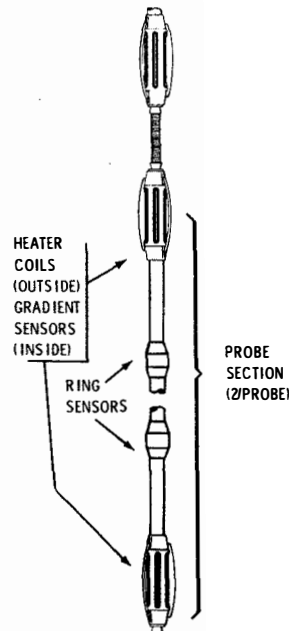

SENSOR TYPE: PLATINUM RESISTOR

SENSOR CIRCUITS:

- SETS OF FOUR SENSORS
- TWO COMBINATIONS (DIFFERENCE & AMBIENT) SELECTED BY INTERNAL LOGIC

DYNAMIC RANGE:

- TEMP DIFFERENCE (BRIDGE)
 - HI SENSITIVITY $\pm 2^\circ \text{K}$ (200 $^\circ \text{K}$ TO 250 $^\circ \text{K}$)
 - LO SENSITIVITY $\pm 20^\circ \text{K}$ (200 $^\circ \text{K}$ TO 250 $^\circ \text{K}$)
- AMBIENT TEMP (RESISTANCE)
 - 200 $^\circ \text{K}$ TO 250 $^\circ \text{K}$
- CABLE THERMOCOUPLES (ALONG PROBE CABLES)
 - 90 $^\circ \text{K}$ TO 350 $^\circ \text{K}$ (ACCURACY 0.3 $^\circ \text{C}$)
- THERMOCOUPLE REF JUNCTION (IN ELECTRONICS)
 - 20 $^\circ \text{C}$ TO +60 $^\circ \text{C}$ (ACCURACY 0.1 $^\circ \text{C}$)
- CONDUCTIVITY RANGE: 5×10^{-6} TO 1×10^{-3} CAL/CM-SEC- $^\circ \text{C}$

APR 69 5178.3.39

APOLLO LUNAR SURFACE DRILL

TENTATIVE

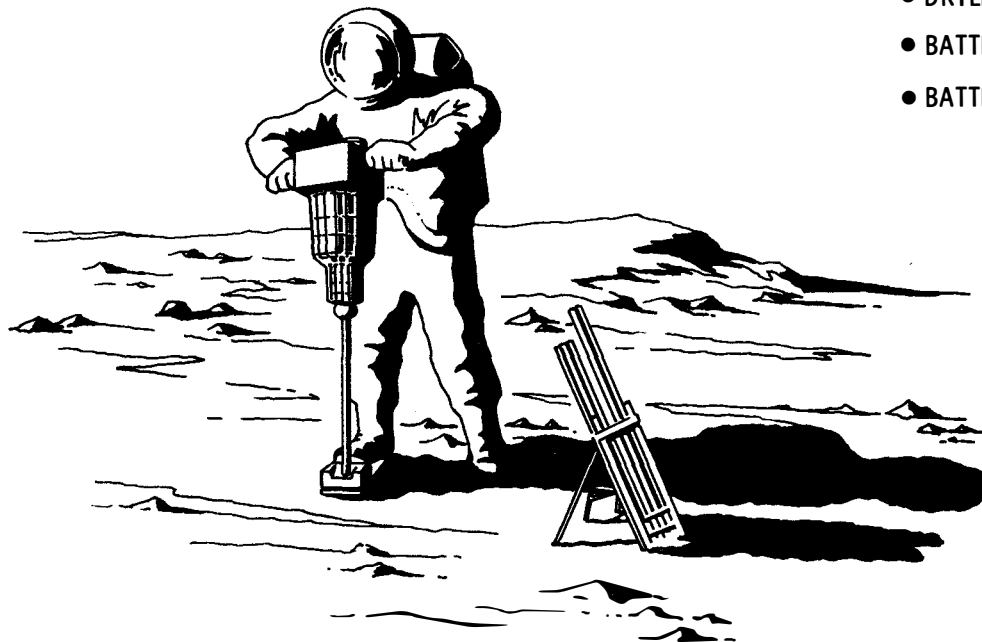

- EARTH WEIGHT, LB: 29.54 (TOTAL)
- STOWED SIZE, IN.: 22.7 X 9.6 X 7
(NOT INC DRILL STRING & CAPS)
- DRILL OPERATED BY SELF-CONTAINED BATTERY
- BATTERY INSTALLED 5 DAYS PRELAUNCH
- BATTERY SHELF LIFE { DRY: 2 YR
ACTIVATED: 30 DAYS
- DRILLING PRINCIPLE: ROTARY – PERCUSSION
- TORQUE REACTION SYSTEM: NONE
(MINIMAL VERTICAL & ROTARY REACTION, EVEN IN ROCK)
- DRILLING TIME: 5 TO 15 MIN/HOLE
(DEPENDING ON MATERIAL)
- APPROX 40 MIN FOR PREPARATION, DRILL WITHDRAWAL, & ENCASEMENT
- INSTALLATION/REMOVAL OF SHEATH (CASING) IN UNCONSOLIDATED MATERIAL TBD

JAN 69 5178.3.40

CHARGED-PARTICLE EXPERIMENT CHARACTERISTICS

PHYSICAL PARAMETERS
 SIZE, IN: 11.3 x 8.5 x 4.5
 EARTH WT, LB: 5.8
 POWER, W: { 3.0 DAY
 (APPROX) { 6.1 NIGHT MAX

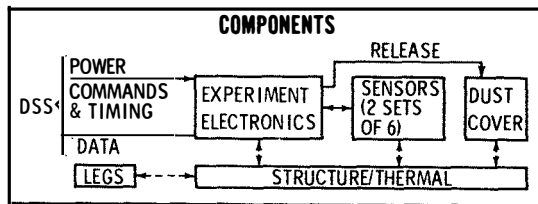

KEY FEATURES
 SENSORS CANNOT OPERATE AT ATMOSPHERIC PRESSURE (CALIBRATE IN VACUUM)
 THERMOSTATICALLY CONTROLLED HEATER

COMMUNICATIONS

<p>COMMANDS:</p> <ul style="list-style-type: none"> • POWER OPER/STBY/OFF • 8 SPECIAL CMDs FOR: <ul style="list-style-type: none"> DUST COVER REMOVAL (1) AUTO/CMD THERMAL CONTROL (2) AUTO/CMD VOLTAGE PROGRAM TO SENSOR (3) CHANGE SENSOR GAIN (2) • BACKUP FROM TIMER TO REMOVE DUST COVER 	<p>DATA:</p> <ul style="list-style-type: none"> • 6 DIGITAL WORDS PER ALSEP FRAME 99 BPS (APPROX) • 97% SCIENCE, 3% HK • 19.3 SEC NORMAL REP RATE • 6 ANALOG ENG PARAMETERS SAMPLED ONCE PER 54-SEC ALSEP SEQUENCE
--	---

DISPLAY: PRINTER/TV

OPERATIONS

<p><u>DEPLOYMENT</u></p> <ul style="list-style-type: none"> • LOCATE 10 FT FROM CENTRAL STATION • LEVEL ± 2.5 • ALIGN $\pm 2^\circ$ WRT SHADOW (SCIENTIFIC & THERMAL) <p>APPROX TIME, 2 MIN</p>	<p><u>POST DEPLOYMENT</u></p> <ul style="list-style-type: none"> • TURN ON (OPER) PRE-ASCENT • READ BASELINE DATA (COVER ON) • AFTER ASCENT REMOVE DUST COVER • CONTINGENCY CORRECTIVE ACTIONS
--	--

APR 69 5178.3.41

CHARGED-PARTICLE EXPERIMENT SENSOR

SENSOR TYPE: CHANNELTRON[®] ELECTRON MULTIPLIER
PHYSICAL ANALYZERS
FIELD OF VIEW: $4^{\circ} \times 20^{\circ}$
ENERGY RANGE: 40 ev TO 70 kev
FLUX LEVEL: 10^5 TO 10^{10} PARTICLES/CM²/SEC/STERADIAN

MODES OF OPERATION: INTERNAL PROGRAM STEPS
DEFLECTION VOLTAGE THROUGH 8 LEVELS
(± 35 , ± 350 , ± 3500 , BACKGROUND & CAL)
BASIC DATA WORD: 19-BIT COUNTERS FOR EACH
OF 4 C-TYPE & 20-BIT COUNTERS FOR 1 C-TYPE
& HELIX
EACH READING COVERED BY 2 ALSEP WORDS
WITH FLAG (ID) IN 20TH BIT WHEN AVAILABLE

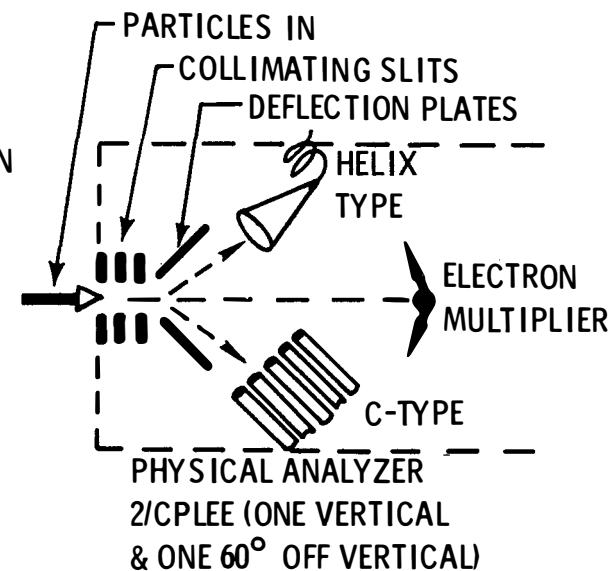

OCT 68 5178.3.42

SEISMIC EXPERIMENT SUMMARY

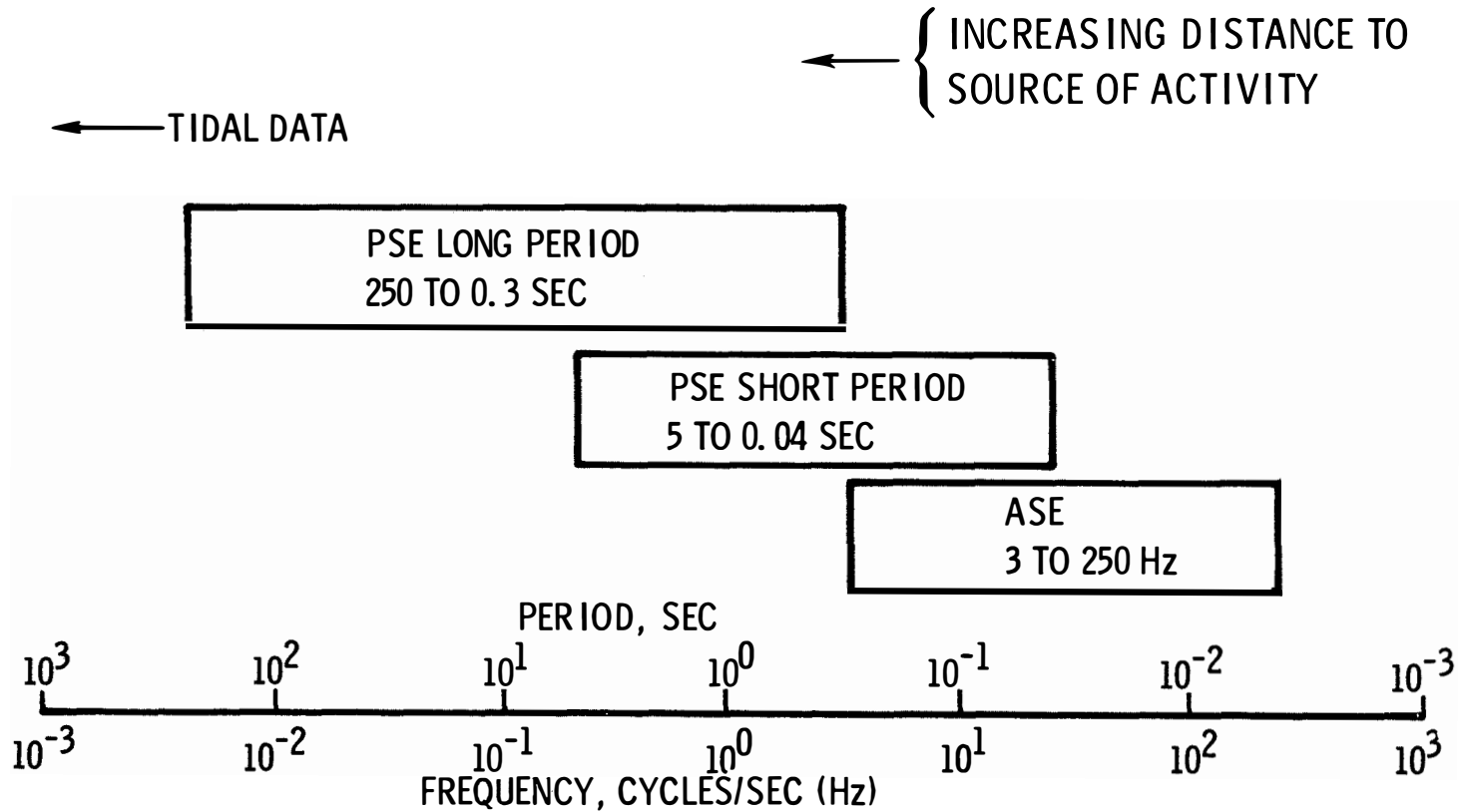

PARTICLE EXPERIMENTS SUMMARY

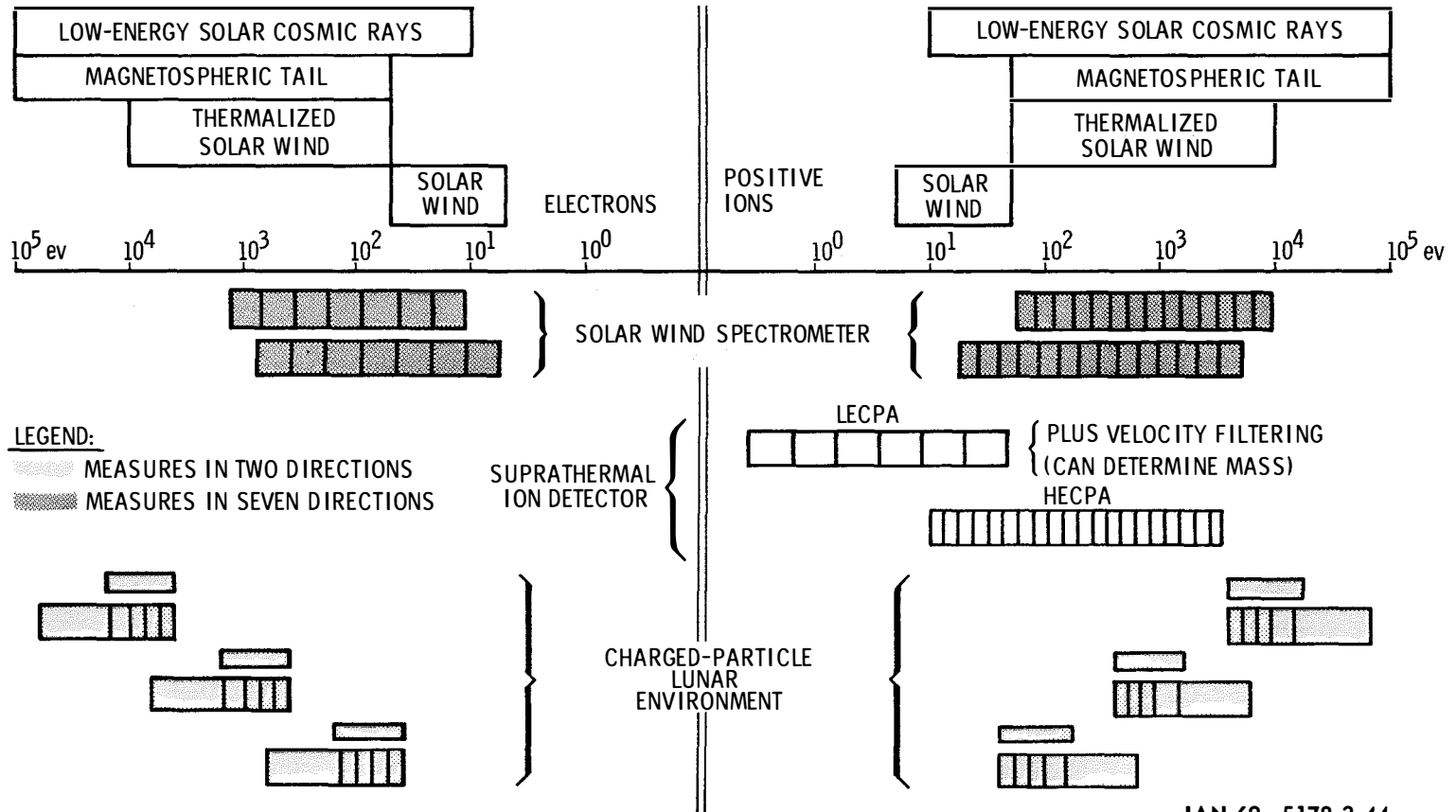

LEVEL AND ALIGN INDICATORS

BUBBLE

RING ON FACE
INDICATES
REQUIRED
SETTING

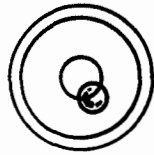

USED ON:
ANTENNA
LSM
SIDE
CPLEE
PSE HAS BALL

COMPASS

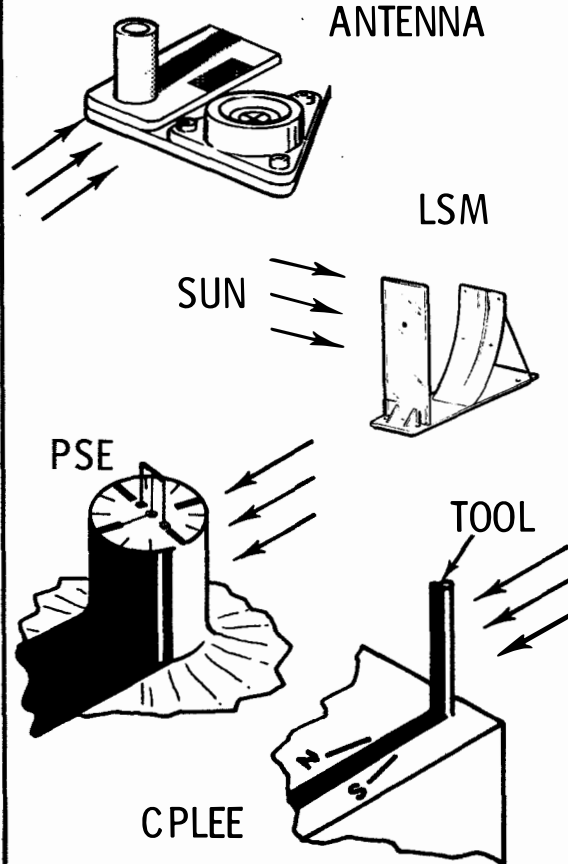

PAINT

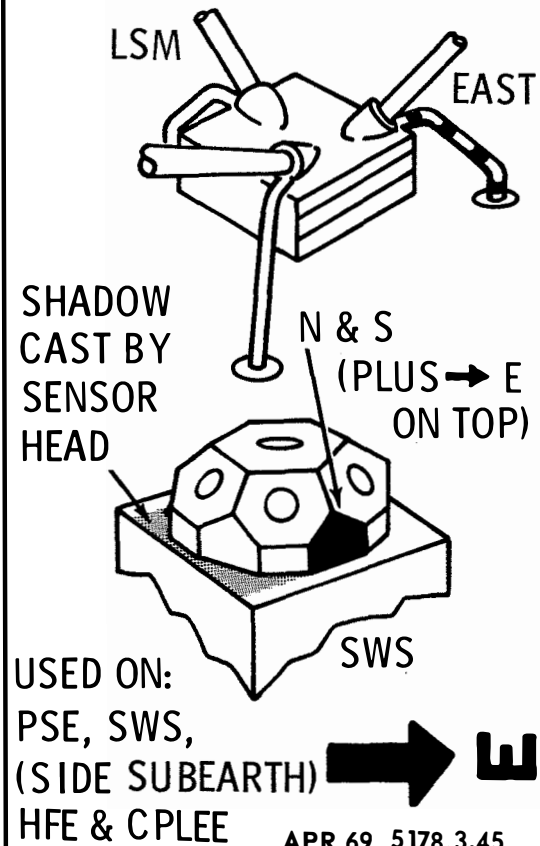

USED ON:
PSE, SWS,
(SIDE SUBEARTH)
HFE & CPLEE

APR 69 5178.3.45

CABLES, REELS AND CONNECTORS

CONDUCTORS (COPPER)
WIDTH 0.025 IN. } EQUIV #32 AWG
THICKNESS 0.002 IN. }
SPACING 0.050 IN. CENTER TO CENTER

RESISTANCE:

TEMP, °C	OHMS/1000 FT
-175	4.4
20	18.8
125	26.5

MUTUAL CAPACITANCE: 5 PF/FT

INSULATION ('KAPTON' H-FILM, FEP TEFLON SANDWICH)

KAPTON: 0.002 IN. THICKNESS (OUTER)

FEP TEFLON: 0.002 IN. THICKNESS (INNER)

RESISTANCE: 3×10^6 MEG OHMS/FT

CABLE

WEIGHT \approx 0.5 LB/1000 FT/ CONDUCTOR

ALSO USES OVER 4000 CONDUCTOR-FT

(SAVES 10 LB COMPARED TO ROUND CABLE)

USES MULTIPLE CONDUCTORS IN PARALLEL

FOR HEAVY CURRENTS

CONNECT EVERY OTHER LEAD FOR SHIELDING

UNREELS IN BOTH
DIRECTIONS
SIMULTANEOUSLY

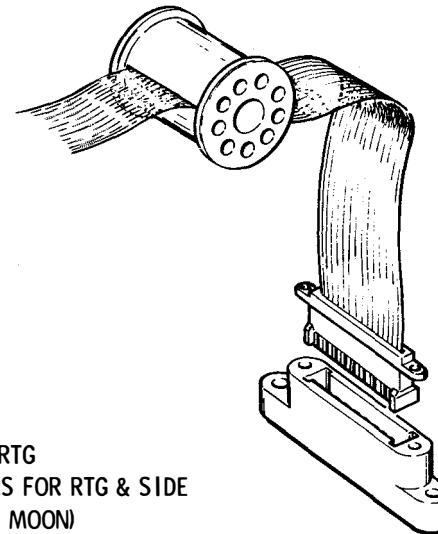
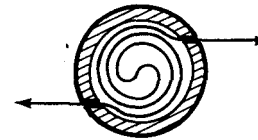

SPECIAL CABLE FOR RTG
SPECIAL CONNECTORS FOR RTG & SIDE
(TO BE MATED ON THE MOON)

JAN 69 5178.3.46

ASTRONAUT PROVISIONS

LEGEND

P = PRIMARY CONSIDERATION
 S = SECONDARY CONSIDERATION

ACTIVITY	CONSTRAINTS						COMMENTS
	SAFETY			CAPABILITY			
	BIOMED	TEMP	PUNCTURE	MOBILITY	DEXTERITY	VISUAL	
UNLOADING FROM LM	S	P	P	P			THERMAL SHIELD FOR CASK
RTG FUEL TRANSFER		P		P		S	SPECIAL TOOLS
300-FT TRAVERSE	P	P	P	P		P	BARBELL CARRY (SUITCASE BACKUP)
ELECT CONNECTIONS			P		P	P	2(RTG & SIDE)
EQUIP DISASSEMBLY		P	P		P	P	SPECIAL TOOL; BOYD BOLT FASTENER
EXPER CARRY	P		P		S		SPECIAL TOOL
LEVEL & ALIGN				P	P	P	BUBBLE, SUN COMPASS, PAINT
ANTENNA ALIGN	P		P				SPECIAL KNOBS & DIALS; ON MAST
BACKUP SWITCHES				P	P	P	MAINLY BACKUP; TOOL OPERATED

WEIGHT SUMMARY

FOR ALSEP 1

EQUIPMENT	SUBPACKAGE 1	SUBPACKAGE 2	EXTERNAL	TOTAL
STRUCTURE/THERMAL	25.49	21.73		47.22
POWER	5.07	28.62	60.0	93.69
DATA	33.47	2.06		35.53
EXPER CABLES	2.06	1.68		3.74
PSE	23.94	0.17		24.11
LSM	17.55			17.55
SWS	11.68			11.68
SIDE		19.41		19.41
SPECIAL TOOLS		20.00		20.00
TOTAL	119.26	93.67	60.0	272.93

WEIGHT LEFT ON LM= 45 LB

DEC 67 5178.3.48

ALSEP 1 DAY TIME POWER

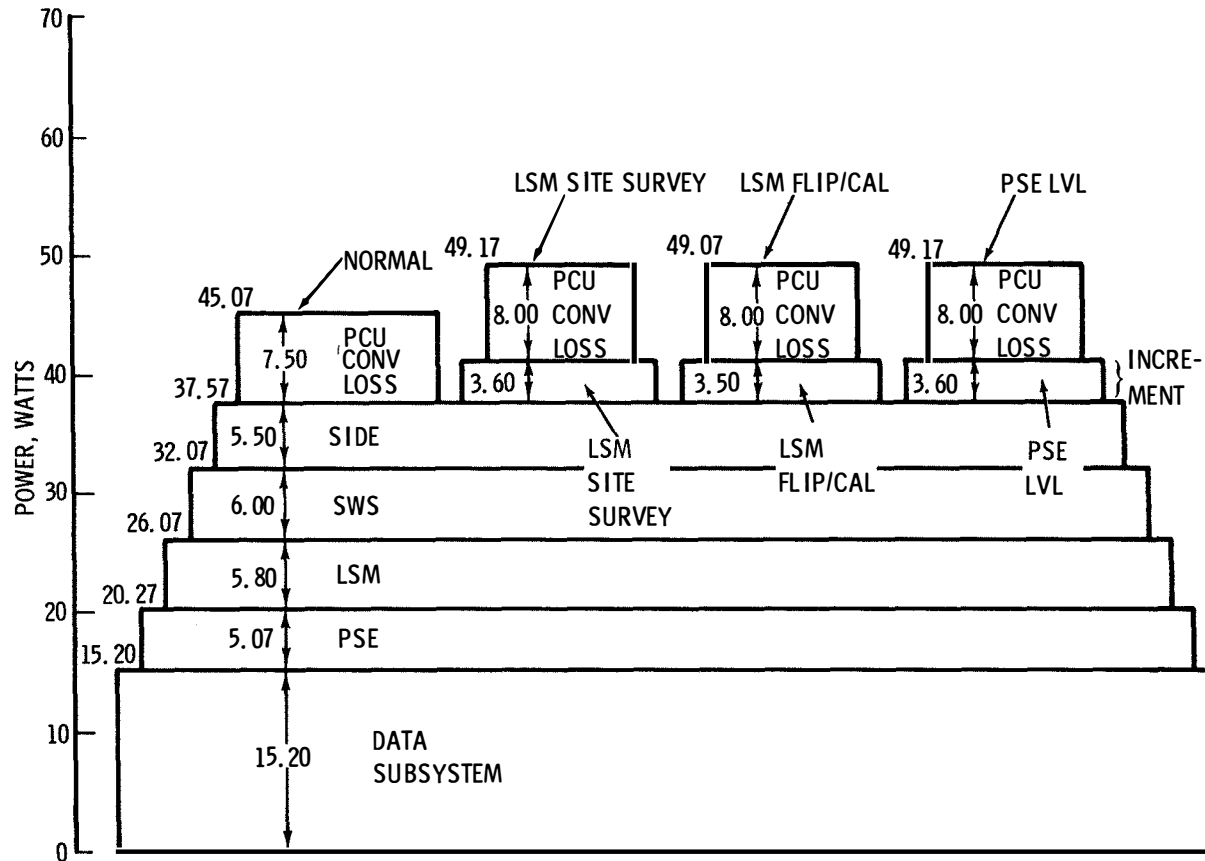

ALSEP 1 NIGHT POWER

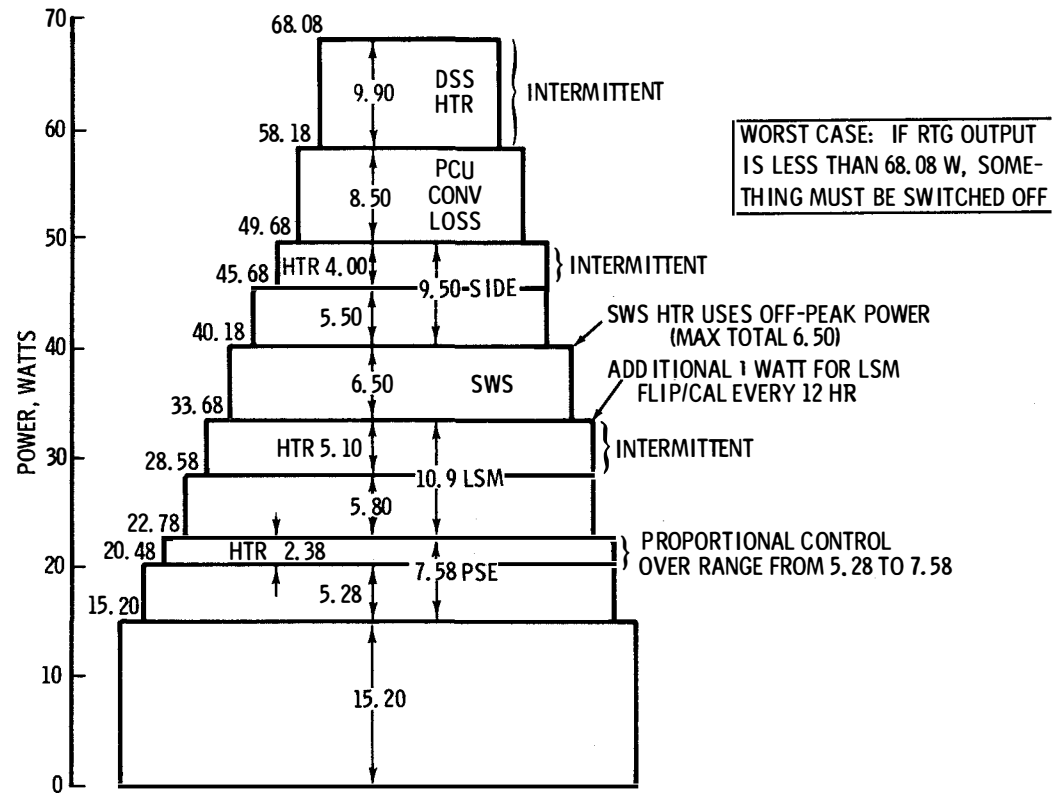

ALSEP 1 DATA SUMMARY

NORMAL BIT RATE (1.06 KBPS)		S/T	POWER	DSS	PSE	LSM	SWS	SIDE	NOT USED	COMMENTS
CMD	POWER CONTROL	2	4	4	3	3	3	3	3(a)	} TOTAL 100
	OTHER OPERATIONS	—	2	9	15	8	1	5	35	
NUMBER OF WORDS	PER ALSEP FRAME	—	—	5(b)	43	7	4	5	—	TOTAL 64(b)
	PER EXPER FRAME	—	—	—	86	7	186	10	—	
REP RATE (SEC)	BASIC FRAME	—	—	0.6	1.2	0.6	28.1	1.2	—	
	COMPLETE CYCLE	—	—	54	1.2	9.6	449	3710	—	
NUMBER OF PARAMETERS	SCIENCE	—	—	—	7	3	8	5	—	VARIOUS SETTINGS
	HK, IN EXPER FORMAT	—	—	6(c)	1	25	92	195	—	INC CAL SIGNALS
	HK, IN ALSEP ADC	19	22	24	8(d)	—	—	—	} 15	TOTAL 90
	SCIENCE, IN ALSEP ADC	—	—	—	—	—	—	2		

(a) MAY BE USED FOR TEST; (b) 5 DSS WORDS = ADC OUTPUT PLUS 6 PARAMETERS;

(c) SYNC, FRAME CNTR, BIT RT ID, ALSEP ID, CMD AS RCVD, CMD MAP;

(d) 8 PSE WORDS = 11 PARAMETERS



ALSEP OPERATIONS

- PRELAUNCH PHASE: FROM START OF PRELAUNCH ACCEPTANCE TESTS TO COMPLETION OF INSTALLATION IN LAUNCH VEHICLE
- LUNAR SURFACE PHASE: CREW ACTIVITIES WHILE DEPLOYING ALSEP ON LUNAR SURFACE
- LUNAR MISSION PHASE: INITIAL START-UP ACTIVITIES AT MCC FROM FIRST COMMAND (XMTR ON) TO COMPLETION OF EXPERIMENT PREPARATION FOR NORMAL OPERATION (OVERLAPS APOLLO LUNAR MISSION)
- FORTY-FIVE DAY CONTINUOUS DATA PHASE: FROM COMPLETION OF EXPERIMENT PREPARATION FOR NORMAL OPERATION TO END OF 45TH DAY AFTER DEPLOYMENT
- ONE-YEAR ALSEP MISSION PHASE: FROM COMPLETION OF 45TH DAY AFTER DEPLOYMENT TO TERMINATION OF OPERATIONS (POSSIBLY TWO YEARS AFTER DEPLOYMENT)

OCT 68 5178.4.1

PRELAUNCH PHASE

KSC ALSEP INTEGRATION

INSTALLATION IN LUNAR MODULE

RTG CASK LOADING

ALSD INSTALLATION

KSC ALSEP INTEGRATION

- CHECK OUT DATA SUBSYSTEM
- CHECK OUT AND INTEGRATE EACH EXPERIMENT
- INTEGRATED SYSTEM TEST

NETWORK TESTS CONDUCTED SEPARATELY

TESTS COMPLETED BEFORE F-60 DAYS

INSTALLATION IN LUNAR MODULE

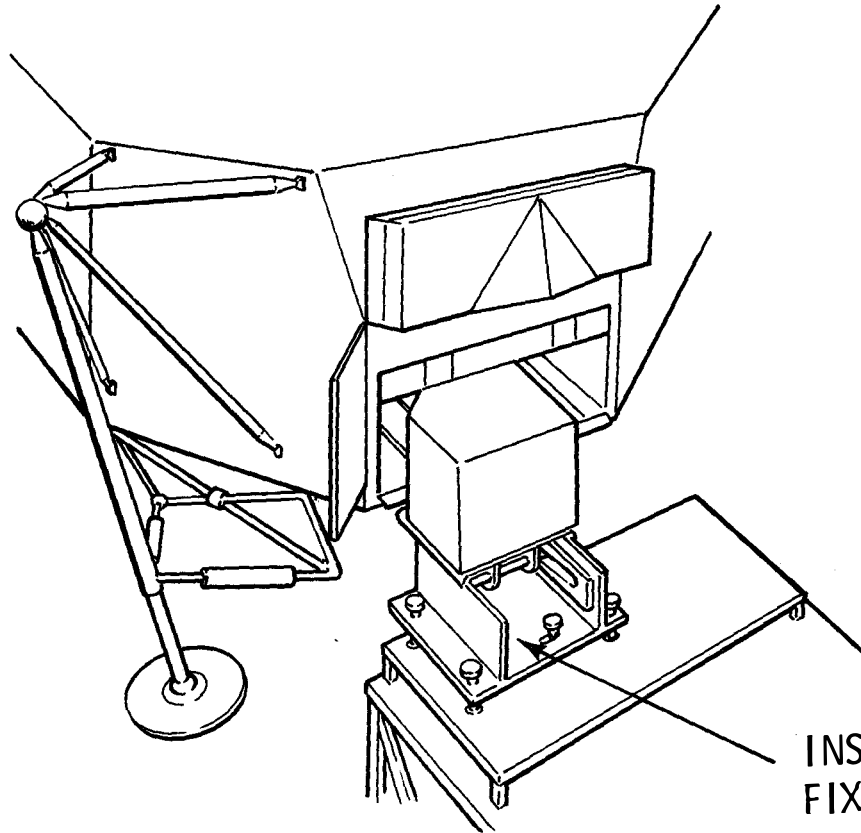

- SLIDE IN
- LIFT AND INSERT PIP PINS
- CLOSE THERMAL DOOR

INSTALLATION
FIXTURE

OCT 68 5178.4.4

RTG CASK LOADING

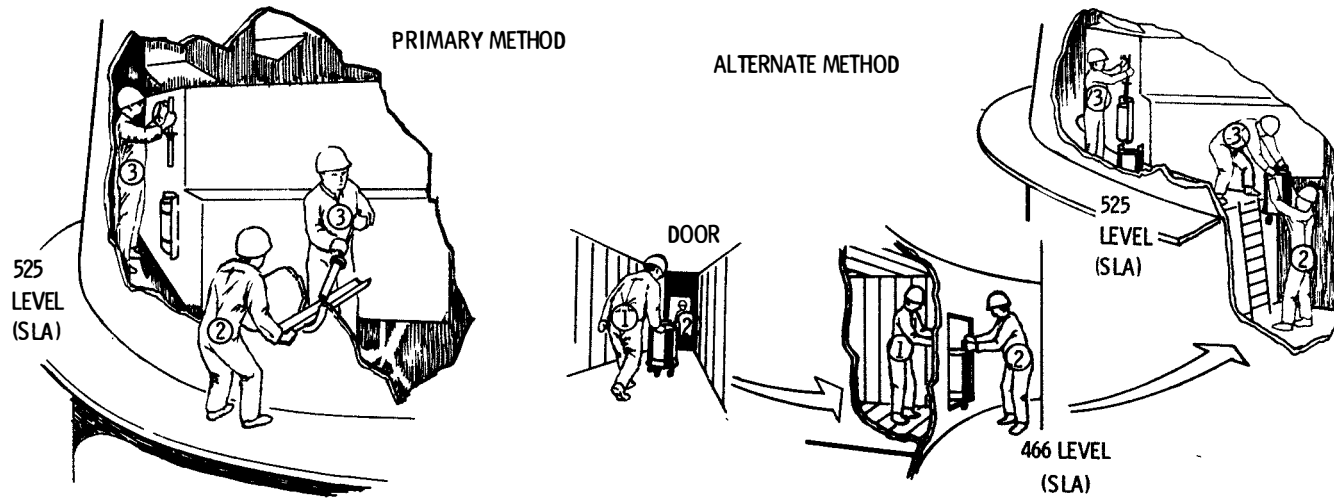

ALSD INSTALLATION

- ALSD BATTERY MUST BE FRESH OR RECHARGED NEAR LAUNCH TIME
- ACCOMPLISHED BY INSTALLING CHARGED ALSD AT F-12 HR (APPROX)
(ALSD HAS BEEN FIT-CHECKED PRIOR TO ALSEP INSTALLATION)
- ALSD HAND-CARRIED TO SEQ BAY
- OPEN SEQ BAY DOOR
- INSERT ALSD
- INSTALL PIP-PIN
- CLOSE SEQ BAY DOOR

LUNAR SURFACE PHASE

ALSEP
DEPLOYMENT
TASKS
ASSOCIATED
WITH LM

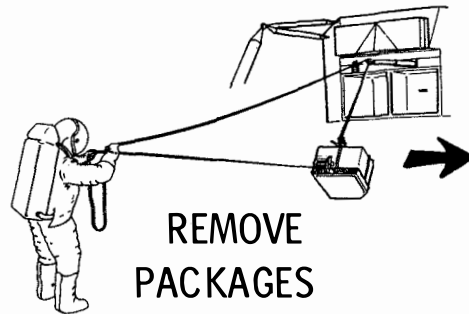

TRANSFER
FUEL

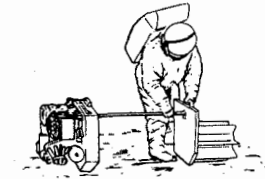

PREPARE FOR TRAVERSE



TRAVERSE

ALSEP
DEPLOYMENT
TASKS AT
EXPERIMENT
SITE

DEPLOY
CENTRAL
STATION



DEPLOY
ANTENNA



DEPLOY
EXPERIMENTS

APR 69 5178.4.7

ALSEP DEPLOYMENT TIMELINE

- **KEY TO MISSION PLANNING**

- THIS TIMELINE IS FOR REFERENCE ONLY – THE FINAL TIMELINE WILL CONFORM TO THE FLIGHT PLAN
- ALSEP 1 TIMELINE, 2-MAN EVA

LEGEND:

————— EVENT LINE



TEAM ACTIVITY. BOTH EVA CREWMEN REQUIRED TO ACCOMPLISH A GIVEN TASK



COUPLED ACTIVITY. BOTH CREW MEMBERS ARE WORKING ON RELATED TASKS AND ARE IN VOICE COMM WITH EACH OTHER. VISUAL CONTACT BETWEEN CREWMEN IS HIGHLY DESIRABLE BUT NOT MANDATORY



UNCOUPLED ACTIVITY. CREW MEMBERS WORKING ON UNRELATED TASKS AND PROCEEDING INDEPENDENTLY

OCT 68 5178.4.8

ACTIVITY TIMELINE

CREW PREPARATION ACTIVITIES NOT INCLUDED IN ALSEP TIMELINE:

- DESCENT TO SURFACE
- PLSS STATUS CHECKS
- EVA COMM CHECK
- OPEN SEQ BAY DOOR

ALSEP DEPLOYMENT ACTIVITIES START WITH CREW MEN ON SURFACE
AND SEQ BAY DOOR OPEN

ACTIVITY TIMELINE (CONT.)

MIN : SEC	COMMANDER ACTIVITY	LM PILOT ACTIVITY	MCC & REMARKS
00:00			
00:54	REMOVE PKG #1 (54 SEC)	MONITOR FOR SAFETY	
00:55		REPORT: PKG #1 OUT	ACK & LOG
02:02	RELOCATE PKG #1 (15 SEC)		(REMOVE PACKAGES)
02:03	MONITOR FOR SAFETY	REMOVE PKG #2 (53 SEC)	ACK & LOG
02:03	RESTOW BOOMS (30 SEC)	RELOCATE PKG #2 (11 SEC)	
	CLOSE SEQ BAY DOOR (01 MIN)	REMOVE ALHT (42 SEC)	
	OBTAIN & STOW GEOLOGICAL TOOLS (42 SEC)	REMOVE & DEPLOY ALSEP TOOLS (01 MIN 30 SEC)	
04:26	REPORT: READY FOR FUEL TRANSFER		ACK & LOG

TENTATIVE

REMOVE PACKAGES

- REMOVE PKG #1
RETRIEVE BOOM LANYARD, PULL
PKG OUT & LOWER WITH BOOM.
RELEASE PKG & PLACE IN
TEMPORARY LOCATION
- REPEAT FOR PKG #2

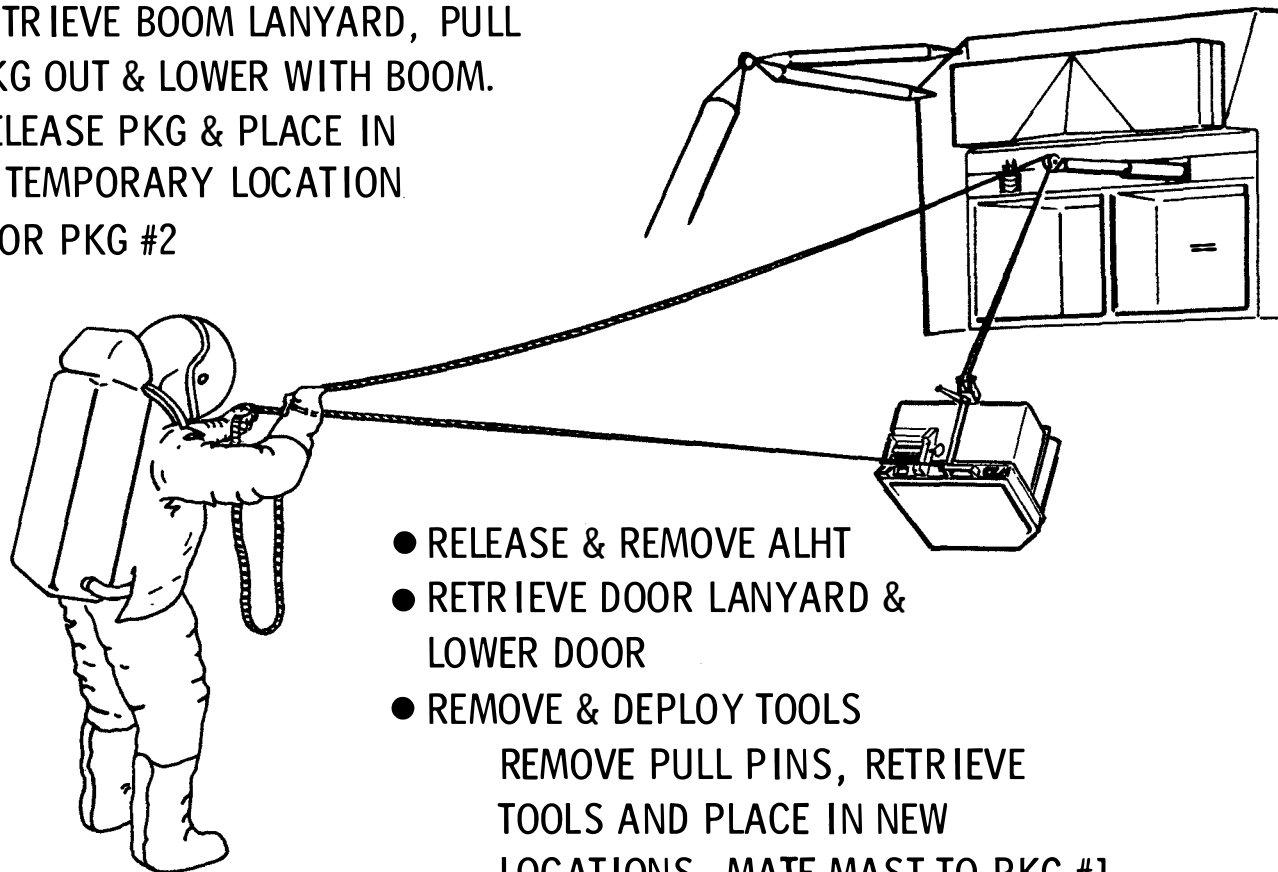

ACTIVITY TIMELINE (CONT.)

MIN : SEC	COMMANDER ACTIVITY	LM PILOT ACTIVITY	MCC & REMARKS
04:27	CONTINUE STOWING GEOLOGICAL TOOLS	ROTATE PKG #2 UPRIGHT & REMOVE SUBPALLET (40 SEC)	(TRANSFER FUEL)
	MONITOR FOR SAFETY & SUPPLY TOOLS	ROTATE FUEL CASK (43 SEC)	
		REMOVE CASK DOME (26 SEC)	
		TRANSFER FUEL CAPSULE (01 MIN 08 SEC)	
07:24	<u>REPORT</u> : RTG FUELED		<u>ACK &</u> <u>LOG</u>
07:25	RETRIEVE SUBPALLET (16 SEC)	ASSEMBLE BARBELL CONFIGURATION (27 SEC)	(PREPARE FOR TRAVERSE)
07:52	<u>REPORT</u> : START OF TRAVERSE		<u>ACK &</u> <u>LOG</u>
07:53	CARRY SUBPALLET & ALHT LEAD TRAVERSE PICK ROUTE REST AS NECESSARY (5 MIN 52 SEC)	CARRY BARBELL REST AS NECESSARY (5 MIN 52 SEC)	(TRAVERSE)
13:45	<u>REPORT</u> : TRAVERSE COMPLETE		<u>ACK &</u> <u>LOG</u>

OCT 68 5178.4.12

TRANSFER FUEL

- ROTATE PKG #2 & REMOVE SUBPALLET
USE UHT TO ROTATE PKG #2 UPRIGHT
RELEASE BOYD BOLTS, REMOVE SUBPALLET FROM PKG #2
- ROTATE FUEL CASK FOR FUEL TRANSFER
RETRIEVE CASK LANYARD
ROTATE LEVERS
PULL SPLINE
ROTATE CASK TO DESIRED ANGLE
- REMOVE CASK DOME USING DRT
- TRANSFER FUEL CAPSULE
ENGAGE FTT WITH CAPSULE
LOCK TOOL TO CAPSULE TO RELEASE
FROM CASK
WITHDRAW CAPSULE
LOWER INTO RTG
RELEASE TOOL FROM CAPSULE TO
LOCK IN RTG

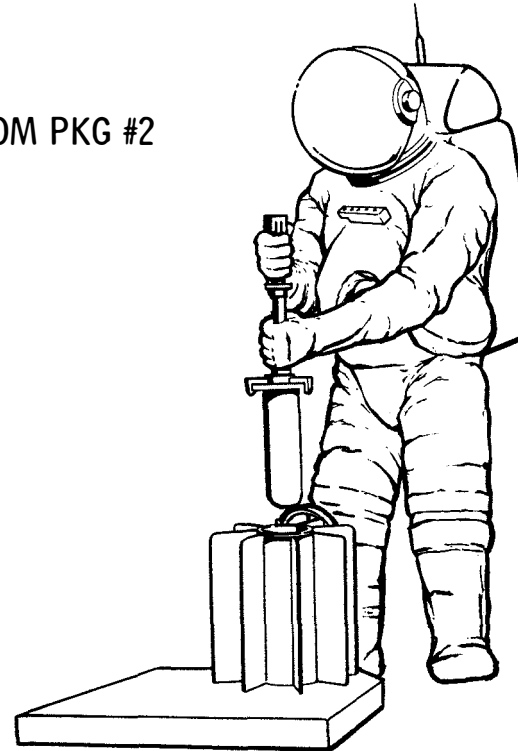

APR 69 5178.4.13

PREPARE FOR TRAVERSE

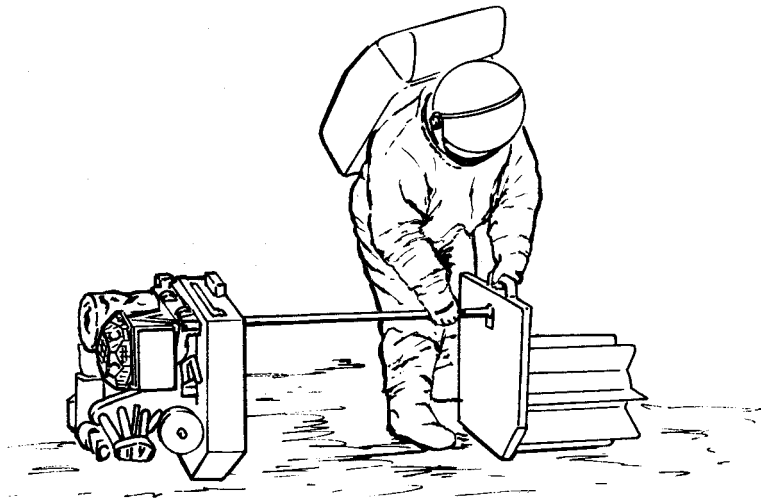

- ROTATE & RE-ORIENT PKG #2
- JOIN MAST TO PKG #2
(ALREADY MATED TO PKG #1)

APR 69 5178.4.14

TRAVERSE

- COMMANDER
CARRIES SUBPALLET & ALHT
LEADS & PICKS ROUTE
- LM PILOT
CARRIES ALSEP BARBELL
- REST, AS NECESSARY
- COMMANDER PICKS DEPLOYMENT SITE

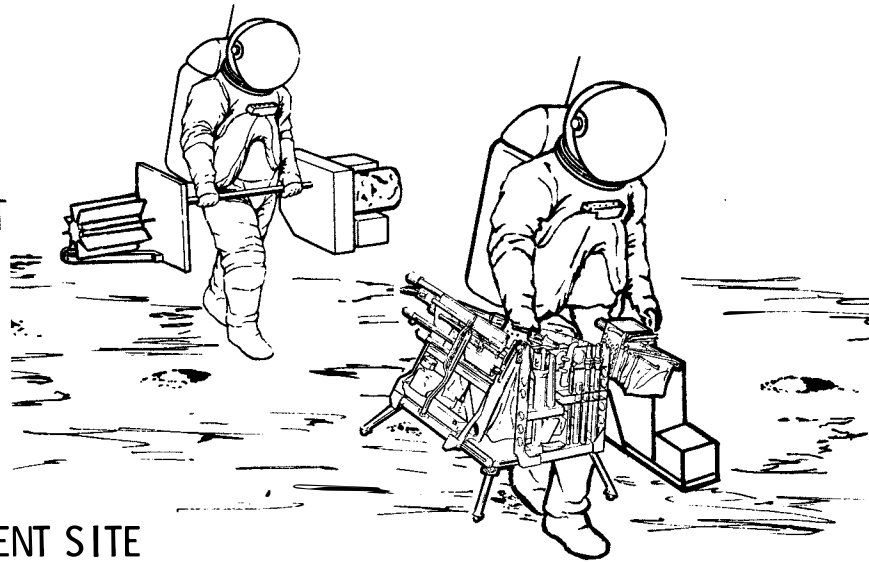

ACTIVITY TIMELINE (CONT.)

MIN : SEC	COMMANDER ACTIVITY	LM PILOT ACTIVITY	MCC & REMARKS
13:46	TEMPORARILY EMPLACE SUBPALLET & ALHT (14 SEC) ROTATE PKG #2 (9 SEC) DEPLOY PKG #2 (01 MIN 3 SEC)	DEPLOY MAST/PKG #1 (22 SEC) MONITOR FOR SAFETY	(DEPLOY CENTRAL STATION)
15:12	REPORT: AMMETER READING		ACK & LOG PET-ZERO
15:13	CONNECT RTG TO CENT STA (02 SEC) DISCONNECT & STOW MAST (58 SEC)	REMOVE SIDE/CCIG & CONNECT CABLE (41 SEC) ACTIVATE RTG SW (2 SEC) REPORT: RTG SW ON	ACK & LOG
16:13			
16:14	ROTATE PKG #1 (14 SEC)	DEPLOY PSE STOOL (18 SEC)	
16:28			

APR 69 5178.4.16

ACTIVITY TIMELINE (CONT.)

MIN : SEC	COMMANDER ACTIVITY		LM PILOT ACTIVITY	MCC & REMARKS	
16:29	RELEASE SWS (32 SEC)		DEPLOY SWS (01 MIN 22 SEC)	<p style="text-align: center;">↑</p> <p style="text-align: center;">(DEPLOY CENTRAL STATION)</p> <p style="text-align: center;">(DEPLOY EXPER)</p> <p style="text-align: center;">(DEPLOY ANTENNA)</p> <p style="text-align: center;">↓</p>	
	RELEASE PSE (32 SEC)		REPORT: ALIGNMENT COMPLETE DEPLOY PSE (01 MIN 05 SEC)		ACK
	REMOVE LSM (54 SEC)		REPORT: ALIGNMENT VALUES DEPLOY LSM (02 MIN 34 SEC)		ACK
TENTATIVE	RELEASE SUNSHIELD (03 MIN)		REPORT: ALIGNMENT VALUES DEPLOY SIDE/CCIG (03 MIN 42 SEC)		ACK
	DEPLOY SUNSHIELD (53 SEC)		OBTAIN METRIC PHOTOGRAPHS OF DEPLOYED ALSEP		GIVE: AZ/EL SETTING
	ASSEMBLE ANTENNA (02 MIN 06 SEC)				COMMAND: XMTR ON REPORT: TM STATUS
	CONFIRM: AZ/EL SETTING (02 MIN 07 SEC)				ACK & LOG
	ACTUATE SW-1 REQUEST: XMTR ON IF ALSEP DOES NOT RESPOND ACTUATE SW-2 AND SW-3				
	REPORT: SW POSITIONS				
28:00					
TBD	RETURN TO LM		RETURN TO LM		

APR 69 5178.4.17

DEPLOY CENTRAL STATION

- DEPLOY MAST/PKG #1

 - DISCONNECT MAST FROM PKG #2
 - CARRY MAST/PKG #1 10 FT

- DEPLOY PKG #2

 - ROTATE PKG #2 UPRIGHT & ALIGN E-W
 - READ AMMETER

- CONNECT RTG TO CENTRAL STATION

 - RELEASE BOYD BOLTS & REMOVE CABLE
 - PLUG IN CABLE
 - ACTIVATE RTG SWITCH

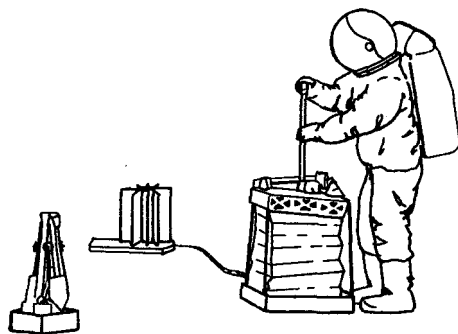

- REMOVE SIDE AND CONNECT CABLE

 - RELEASE/REMOVE SIDE FROM SUBPALLET
 - TEMPORARILY PLACE ON SURFACE

 - PLUG IN CABLE

 - DISCONNECT MAST FROM PKG #1 & STOW TEMPORARILY

 - ROTATE PKG #1 UPRIGHT AND ALIGN E-W

- REMOVE EXPER AND DEPLOY SUNSHIELD

 - REMOVE PSE STOOL FROM SUBPALLET & DEPLOY
 - REMOVE & DEPLOY SWS

 - REMOVE & DEPLOY PSE SENSOR

 - REMOVE LSM & PLACE TEMPORARILY ON SURFACE

 - RELEASE SUNSHIELD & ANTENNA BOYD BOLTS

 - USE TOOL TO CONTROL UPWARD (SPRING)

 - MOTION OF SUNSHIELD

 - REMOVE & DISCARD CURTAIN COVERS

DEPLOY ANTENNA

- ASSEMBLE ANTENNA
 - INSTALL MAST ON CENTRAL STATION
 - INSTALL AIMING MECHANISM ON MAST
 - INSTALL ANTENNA ON AIMING MECHANISM
- ORIENT ANTENNA
 - ENTER COARSE & FINE ADJUSTMENTS IN AZIMUTH
 - ENTER COARSE & FINE ADJUSTMENTS IN ELEVATION
 - LEVEL AIMING MECHANISM BASE
 - ALIGN E-W WRT SHADOW
 - RECHECK LEVEL

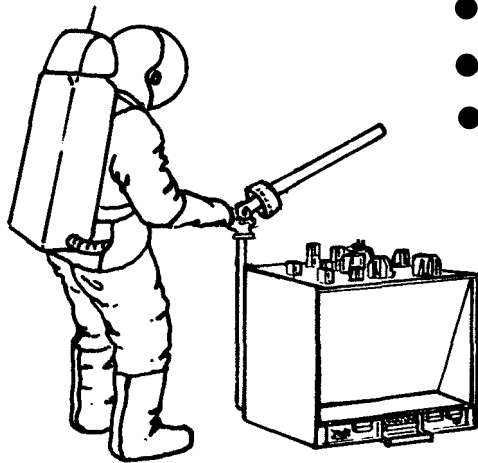

DEPLOY EXPERIMENTS

SWS

CARRY 13 FT
EXTEND LEVELING LEGS
PLACE ON SURFACE
(PARTIALLY
SELF-LEVELING)
ALIGN BY
SHADOWS



PSE

CARRY 10 FT
REMOVE GIRDLE
PLACE ON STOOL
UNFOLD SHROUD
LEVEL BY BALL
INDICATOR
READ ALIGNMENT
BY GNOMON
SHADOW

LSM

CARRY 50 FT
DEPLOY SUPPORT LEGS
PLACE ON SURFACE
UNFOLD SENSOR ARMS
REMOVE PRA COVERS
LEVEL BY BUBBLE
ALIGN BY
SHADOWGRAPH
READ SHADOWGRAPH
ALIGNMENT

SIDE

CARRY 55 FT
PLACE ON SURFACE
DEPLOY GROUND SCREEN
RELEASE CC IG
EMPLACE SIDE ON
GROUND SCREEN
EMPLACE CC IG
LEVEL BY BUBBLE
ALIGN BY
SHADOWS

APR 69 5178.4.20

MSFN/MCC OPERATIONS

- OPERATIONAL CONCEPT
- SCHEDULE OF MONITORING
- MCC MONITORING & CONTROL REQMTS
- OPERATIONAL PHASES

OCT 68 5178.4.21

OPERATIONAL CONCEPT

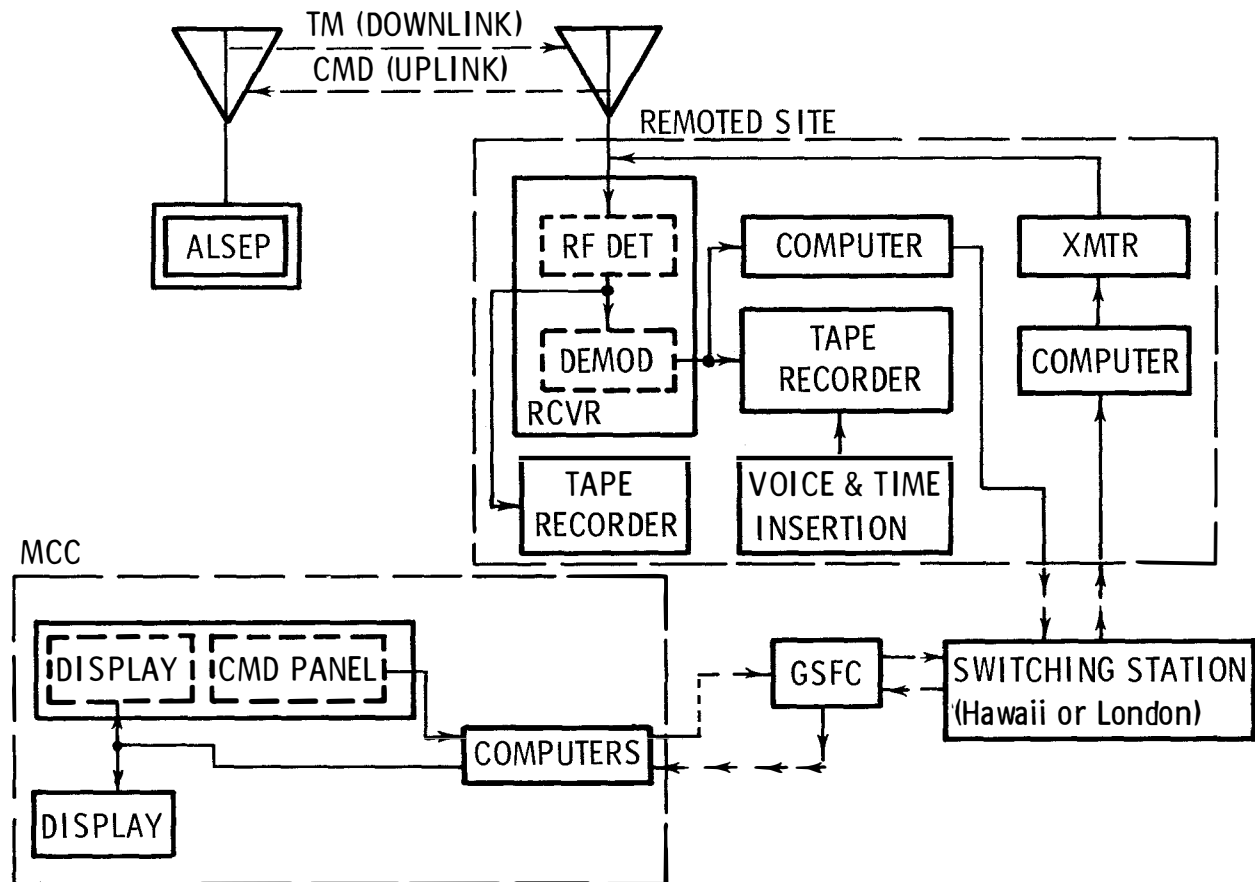

OCT 68 5178.4.22

SINGLE-ALSEP SCHEDULING

TIME PERIOD	≈ F-70 DAYS	0-45 DAYS	45-365 DAYS	365-720 DAYS
ACTIVITIES AT MSFN SITES	NETWORK COMPATIBILITY TESTS (SEVERAL HOURS)	RECORD CONTINUOUSLY ALL ALSEP DATA		IF CONDITIONS WARRANT, ALSEP CAN BE LEFT ON UP TO 2 YR, TERMINATED BY ACCUTRON TIMER
MCC-H ACTIVITIES		MONITOR & CONTROL CONTINUOUSLY	MONITOR & CONTROL 2 HR PER DAY*	

*ALSO LONGER PERIODS, UP TO 60 HR, DURING LUNAR SUNRISE & SUNSET; PLUS EXTENSION WHEN CONTINGENCIES OCCUR

CMD AND TM SUMMARY

BUILDING 4 ALSEPS FOR EARLY APOLLO LUNAR LANDINGS	
UPLINK (CMD)	DOWNLINK (TM)
<ul style="list-style-type: none"> • ONE FREQUENCY, 2119 MHz • 8 DECODER ADDRESSES (2/ALSEP) • 100 ALSEP COMMANDS, 65-75 USED ON ANY SINGLE ALSEP (7-BIT CMD ALLOWS 128, BUT 28 ARE NOT VALID) • ALL COMMANDS ARE RTC'S, NO "LOAD" CAPABILITY IS REQUIRED; (SIDE USES 5 CMDs MULTIPLEXED, 4-CALLED LOADS-TO SET REGISTER & 1 TO EXECUTE) • NO TIME-CRITICAL CMDs EXCEPT PSE FORCED LEVELING (BACKUP TO AUTO MODE) WHERE CMD IS SENT TWICE WITH TIME INTERVAL \pm 10 SEC • MAX 1 CMD/SEC LIMITED BY DECODER 	<ul style="list-style-type: none"> • 4 DIFFERENT S-BAND FREQUENCIES ALLOCATED • DATA RATES: 1.06 KBPS NORMAL, 0.53 KBPS CONTINGENCY (ALSEP 4 HAS ADDITIONAL 10.6 KBPS HBR SELECTED BY CMD; USED ONLY PERIODICALLY TO SUPPORT ASE; ASE REQMT ONCE/WK 15-30 MIN PLUS \approx 1 HR WHEN CREW IS ON SURFACE & \approx 1 HR SEVERAL MONTHS LATER) • 30-FT MSFN ANTENNA ADEQUATE FOR NORM BIT RT; 85-FT REQD FOR HBR • ALSEP FRAME = 64 10-BIT WORDS (0.60377 SEC @ NORM BIT RT) • CMD VERIFICATION WORD (INC MAP) APPEARS ONLY ONCE IN TM STREAM

APR 69 5178 4.24

MULTIPLE-ALSEP SCHEDULING

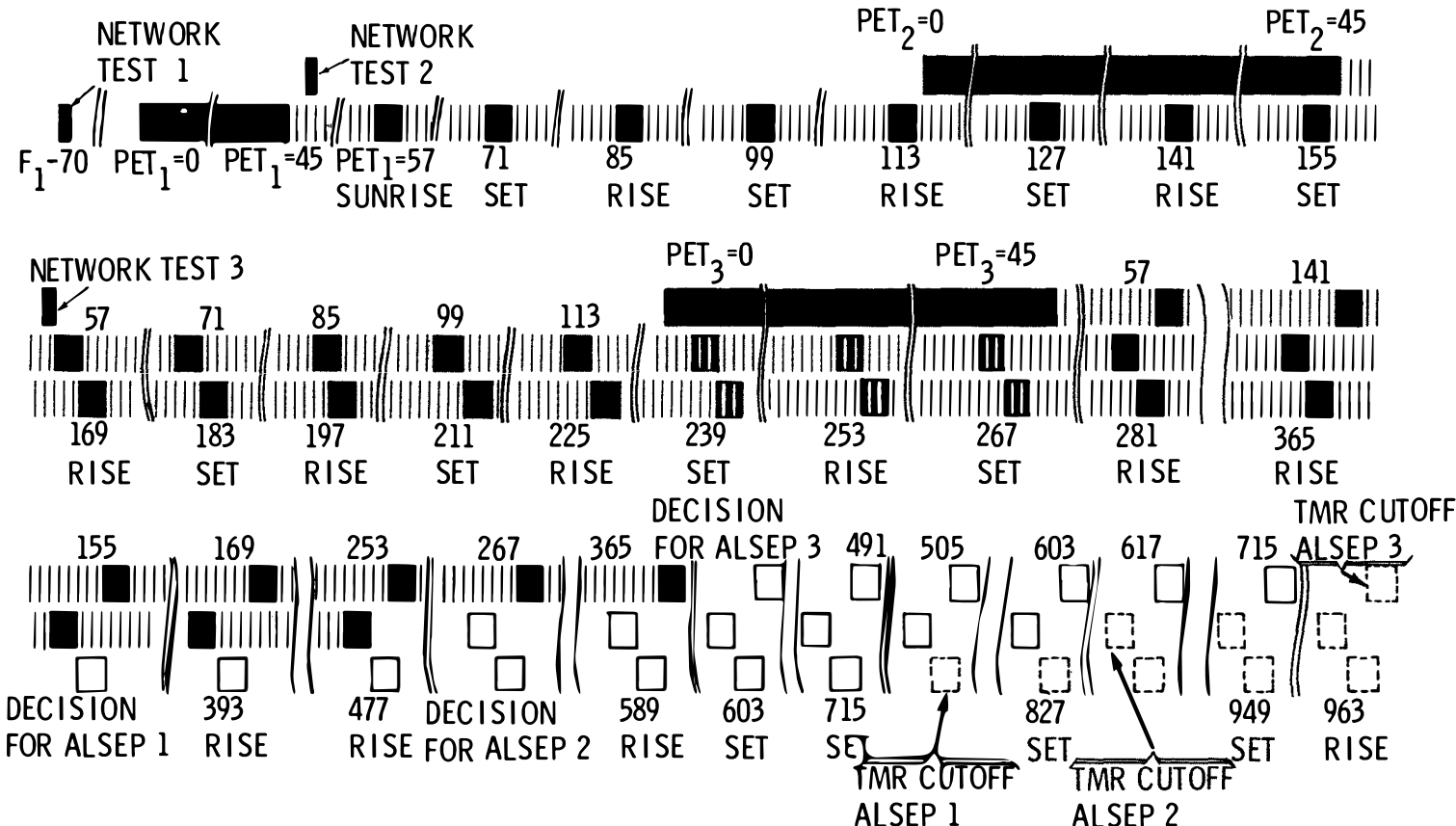

MCC MONITORING AND CONTROL REQUIREMENTS

MONITORING & CONTROL	PHASE		
	INITIAL START-UP	0 TO 45 DAYS	45 TO 365 DAYS
PWR/THERMAL	H	H	H
OTHER ENG STATUS	H	M	C
SCIENCE	P	P+R	R
CMD FUNCTION STATUS	H	M	L
SEND COMMANDS	I+C	E+C	E+C

LEGEND

- H = HIGH PRIORITY
- M = MEDIUM PRIORITY
- L = LOW PRIORITY
- C = CONTINGENCY-ORIENTED
- P = PRINCIPAL INVESTIGATOR
- R = ROUTINES, PREPLANNED
- I = INITIAL TUNE-UP
- E = ENVIRONMENTAL CHANGES (SUCH AS SOLAR FLARES)

OCT 68 5178.4.26

LUNAR MISSION PHASE

- SYSTEM START-UP
- EXPERIMENT START-UP
- ACTIVITIES PHASED TO LM ASCENT
- PRE-SPLASHDOWN CONSTRAINTS

SYSTEM START-UP

ACTIVITY	COMMENT
CREW: REQUESTS XMTR ON MCC: CMD XMTR ON MCC: VERIFY XMTR ON MCC: ADVISE CREW "XMTR ON"	NOTE: START-UP DEPENDS UPON RTG WARM-UP CYCLE.

- THIS ACTIVITY MARKS BEGINNING OF LUNAR MISSION PHASE
- THIS IS THE ONLY CREW/MCC COUPLED ACTIVITY
(THERE IS NO CREW TUNE-UP, CALIBRATION, ETC.)

EXPERIMENT START-UP TIMELINE

HR:MIN	MCC ACTIVITY	STATUS				REMARKS
		PSE	LSM	SWS	SIDE	
TENTATIVE SEQUENCE	CMD XMTR ON					LEGEND: <div style="display: flex; flex-direction: column; gap: 5px;"> <div> OFF</div> <div> STBY</div> <div> OPER</div> <div> SPECIAL</div> </div> <p>MONITOR POWER RESERVE STATUS & ADJUST PDR LOADS BEFORE EACH NEW EXPER, IF NECESSARY</p> <p>EXPER CHECKS CONTINUE CONCURRENTLY</p> <p>LM ASCENT</p>
	RECEIVE TM					
	CHECK TM STATUS					
	CMD LSM OPER					
	CHECK LSM STATUS					
	CMD PSE OPER					
	CHECK PSE STATUS					
	* CMD SWS OPER					
	CHECK SWS STATUS					
	* CMD SIDE OPER					
	CHECK SIDE STATUS					
	CMD DUST ON					
	CHECK DUST STATUS					
	CMD LSM RANGE & OFFSET					
	CMD LSM FLIP/CAL MONITOR FLIP/CAL					

* MAY REQUEST SEVERAL DAYS VACUUM SOAK

OCT 68 5178.4.29

START-UP TIMELINE (CONT.)

HR:MIN	MCC ACTIVITY	STATUS				REMARKS
		PSE	LSM	SWS	SIDE	
TENTATIVE SEQUENCE	CMD PSE UNCAGE					MAY BE PRE-ASCENT
	CHECK PSE					
	CMD SIDE STBY					AS NECESSARY FOR POWER MANAGE- MENT DURING PSE LEVELING
	CMD SWS STBY					
	CMD PSE LEVEL					
	CMD PSE GAIN					
	CMD PSE CAL					REPEAT AS NECESSARY; SITE SURVEY MUST OCCUR BETWEEN 4TH & 5TH FLIP/CAL
	CMD SWS OPER					
	CMD SIDE OPER					
	CMD LSM FLIP/CAL					
	MONITOR FLIP/CAL					
	CMD SWS COVER GO					
	CMD SIDE COVER GO					
	CMD CCIG SEAL BREAK					
	CMD LSM SITE SURVEY					
	MONITOR SURVEY					
	FULL OPERATION					

ACTIVITIES PHASED TO LM ASCENT

- LSM FLIP/CAL REQD APPROX 1 HR BEFORE ASCENT
- PSE UNCAGE MAY BE SCHEDULED BEFORE ASCENT
- MONITOR ALL SCIENTIFIC & ENGINEERING DATA BEFORE, DURING, & AFTER ASCENT TO DETERMINE EFFECTS OF LAUNCH (DUST DETECTOR IS A KEY MEASUREMENT)
- REMOVE DUST COVERS & BREAK COLD CATHODE GAUGE SEAL SHORTLY AFTER ASCENT

PRE-SPLASHDOWN CONSTRAINTS

IF NECESSARY DURING CRITICAL APOLLO MANEUVERS,
ALSEP XMTR MAY BE TURNED OFF. OTHER APOLLO PRIORITIES
MAY TAKE PRECEDENCE OVER ALSEP PRIORITIES.

45-DAY CONTINUOUS DATA PHASE

- MONITOR ENGINEERING & SCIENCE DATA AGAINST LIMITS
- ESTABLISH ENGINEERING DATA TRENDS FOR USE DURING LATER INTERMITTENT OPERATIONS
- ADJUST EXPERIMENTS FOR OPTIMUM SCIENTIFIC DATA COLLECTION & CHANGING ENVIRONMENTAL CONDITIONS AS REQUESTED BY THE PRINCIPAL INVESTIGATOR
- APPLY CORRECTIVE COMMANDS FOR CONTINGENCIES, AS NECESSARY

ONE-YEAR ALSEP MISSION PHASE

- MONITOR ENGINEERING & SCIENCE DATA AGAINST LIMITS & TRENDS ESTABLISHED DURING PREVIOUS CONTINUOUS OPERATIONS
- ADJUST EXPERIMENTS IN ACCORDANCE WITH ROUTINES PRESCRIBED BY THE PRINCIPAL INVESTIGATORS
- APPLY CORRECTIVE COMMANDS FOR CONTINGENCIES, AS NECESSARY
- AT YEAR END, TURN OFF XMTR OR CONTINUE OPERATIONS AS DIRECTED

STRUCTURE/THERMAL SUBSYSTEM

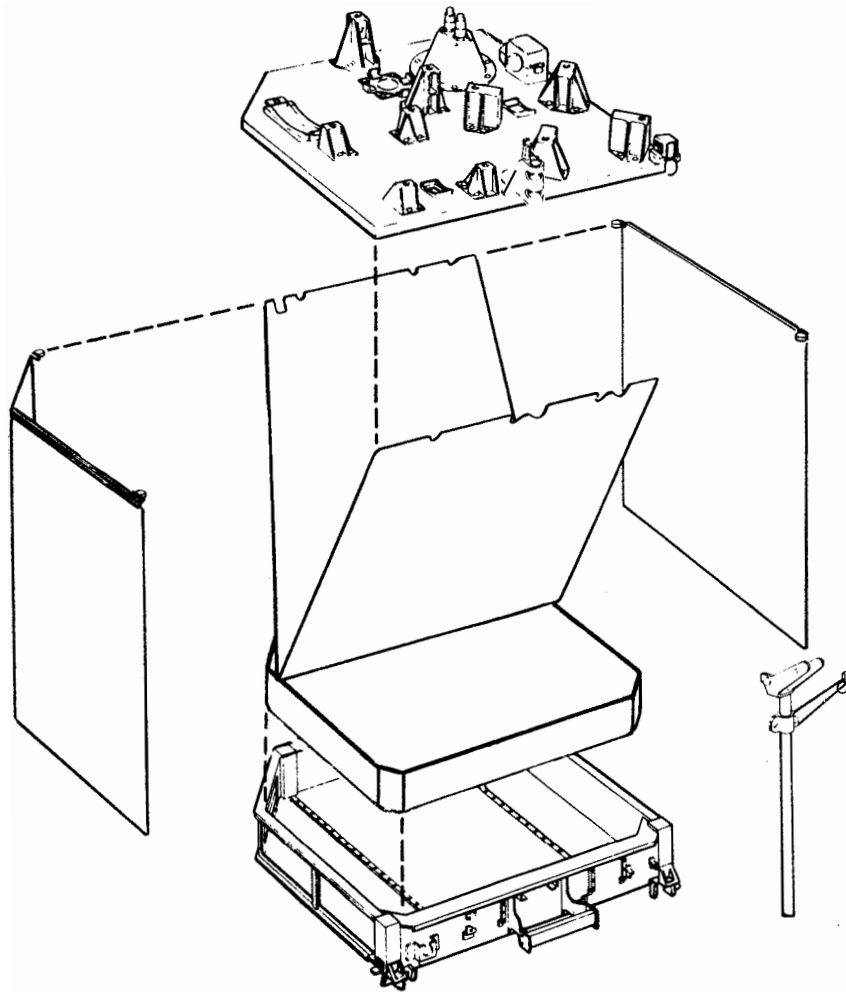

- COMPONENTS & FUNCTION
- DEPLOYMENT
- COMMANDS & DATA

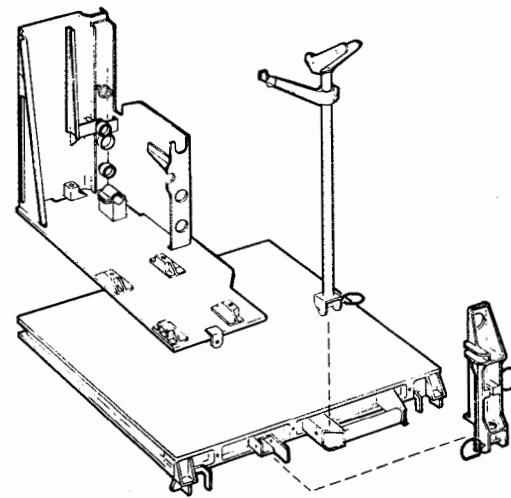

APR 69 5178.5.1

MECHANICAL CRITERIA

- STRUCTURAL ELEMENTS
- WITHSTAND LOADS OF LAUNCH, FLIGHT, & LUNAR LANDING
 - WITHSTAND LOADS ASSOCIATED WITH DEPLOYMENT
 - SUPPORT THE EQUIPMENT ON THE LUNAR SURFACE
- JOINTS, FITTINGS & FASTENERS
- HOLD SECURELY IN LOCKED POSITIONS
 - RELEASE & FUNCTION DURING DEPLOYMENT

SPECIAL JIGS & SHIPPING CONTAINERS PROVIDE PROTECTION FOR PRELAUNCH HANDLING, TRANSPORTATION, & STORAGE

CENTRAL STATION THERMAL CONTROL

MECHANICAL

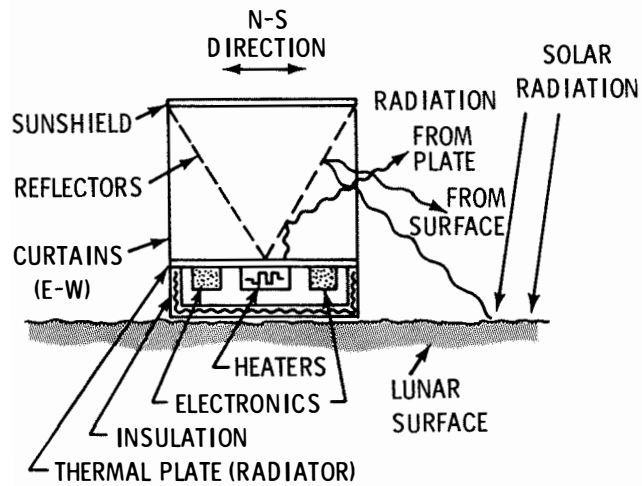

ELECTRICAL

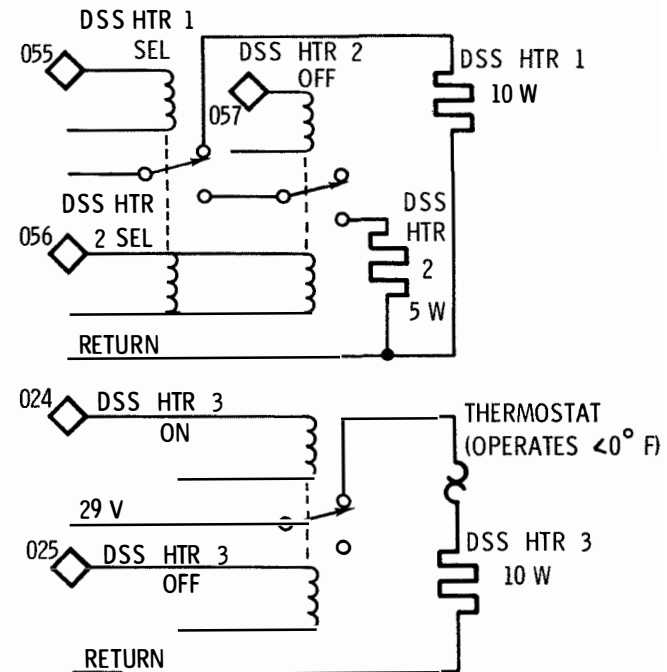

APR 69 5178.5.3

DUST DETECTOR

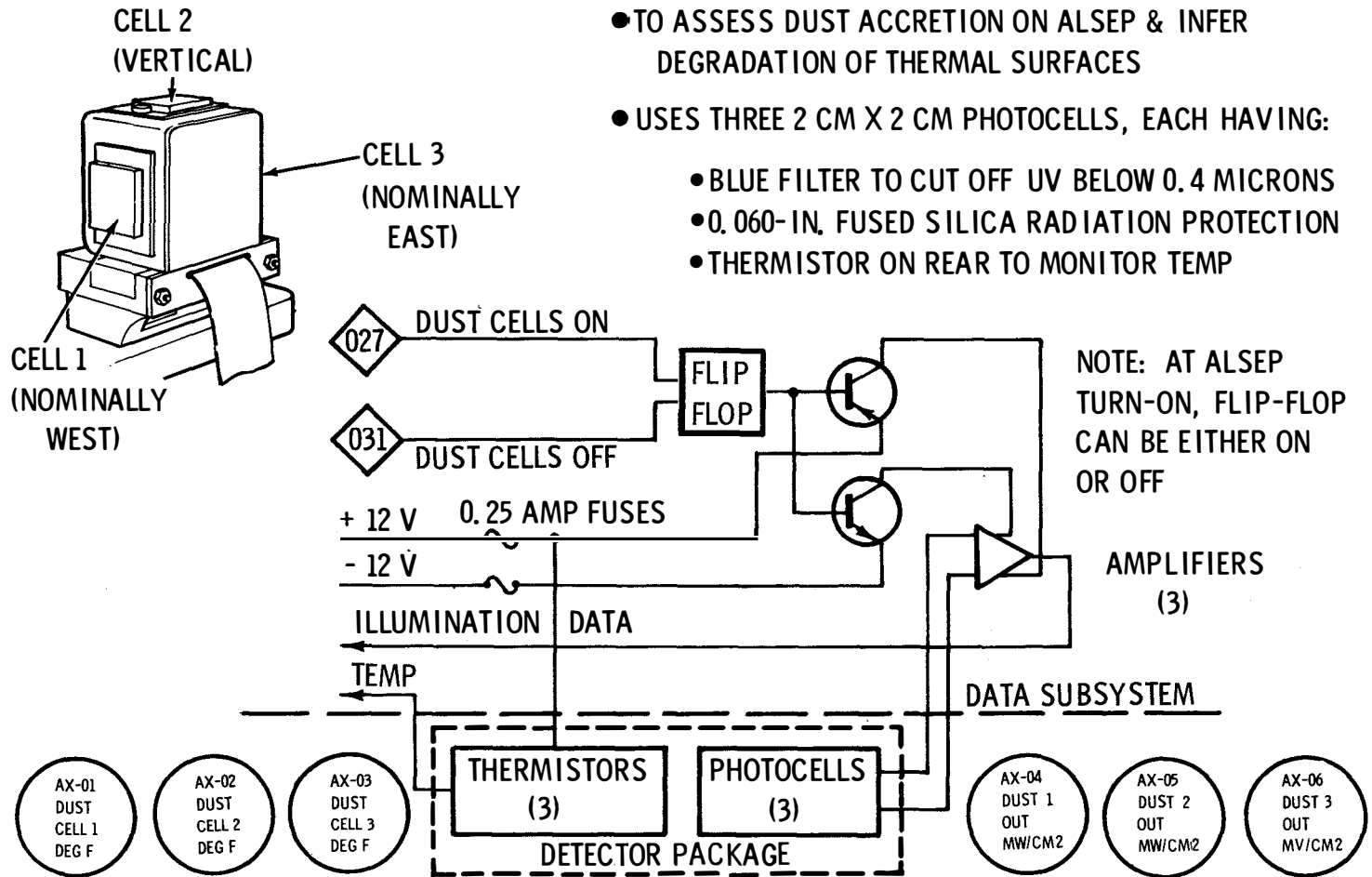

SEPT 68 5178.5.4

FASTENERS

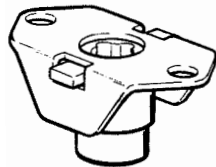
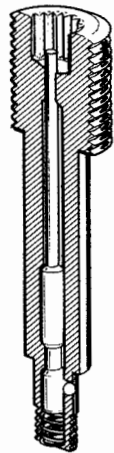
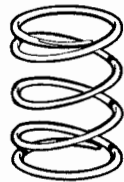
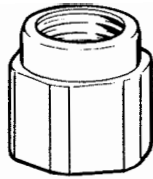

BOYD BOLT

USED FOR TENSION &
SHEAR CONNECTIONS:

EXPER/SUNSHIELD
SUNSHIELD/PRIMARY
STRUCTURE

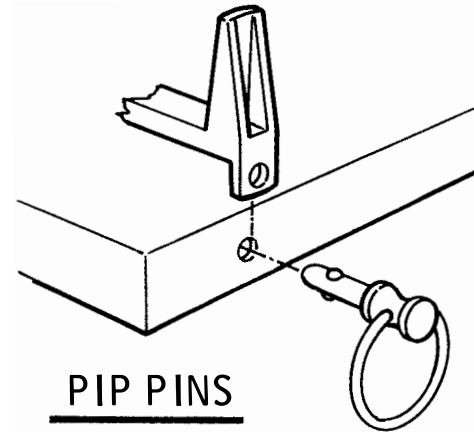

PIP PINS

SPRING-LOADED
DETENT BALLS
USED FOR SHEAR
CONNECTIONS:

SUBPALLET/PALLET
ALSD PALLET
TOOLS SUBPALLET

APR 69 5178.5.5

MAST/CARRY BAR

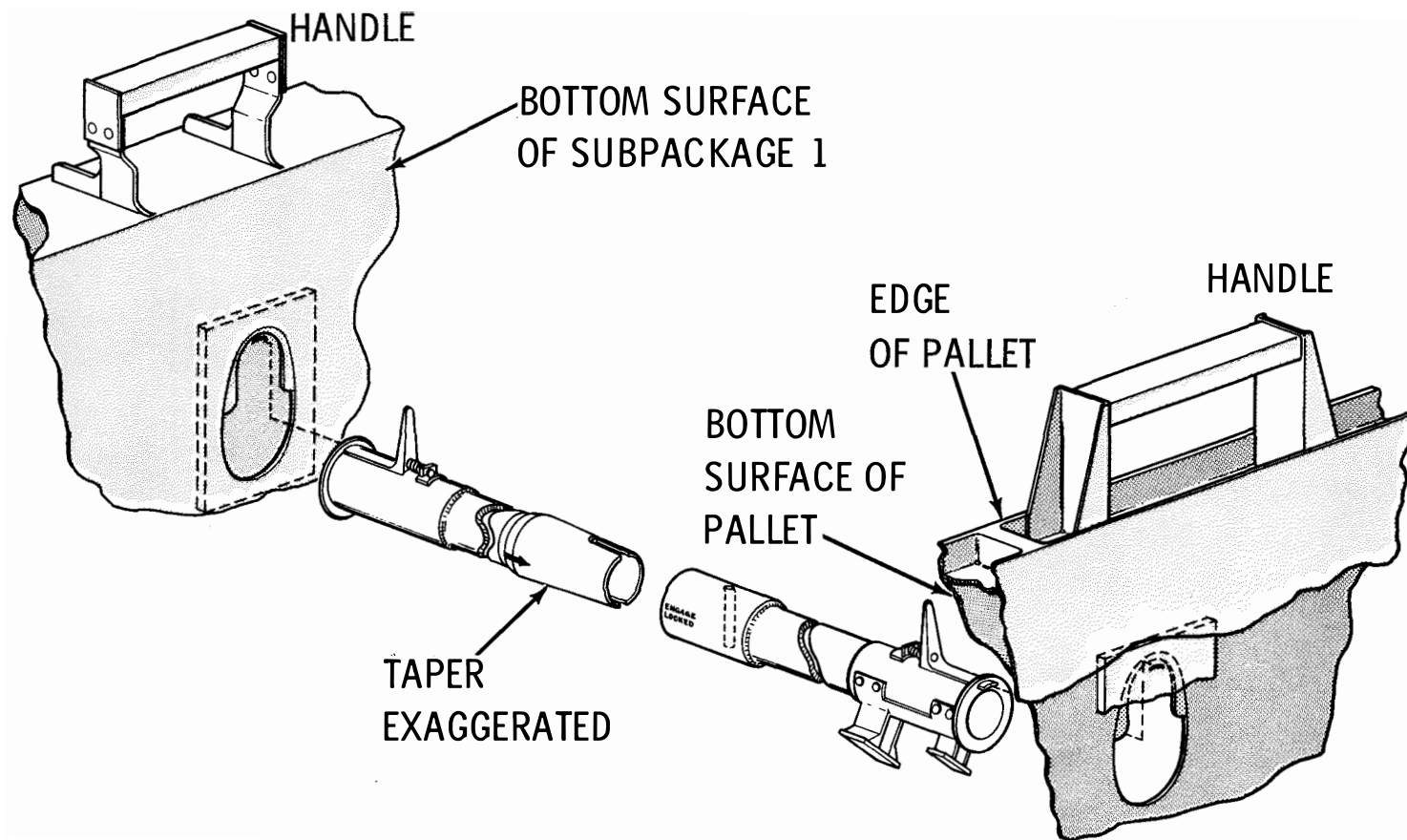

DEC 67 5178.5.6

MAST/PRIMARY STRUCTURE

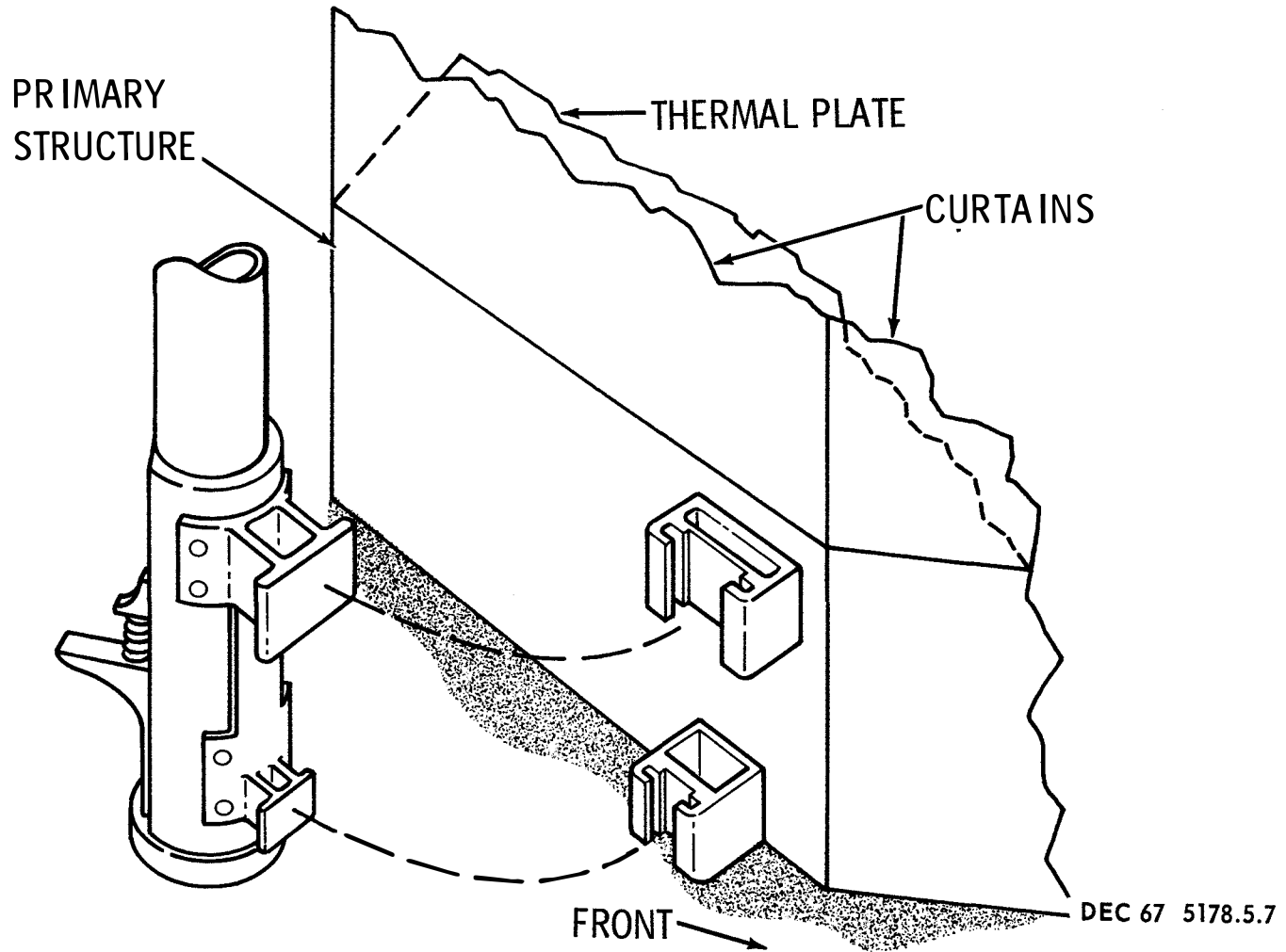

MAST/AIMING MECHANISM

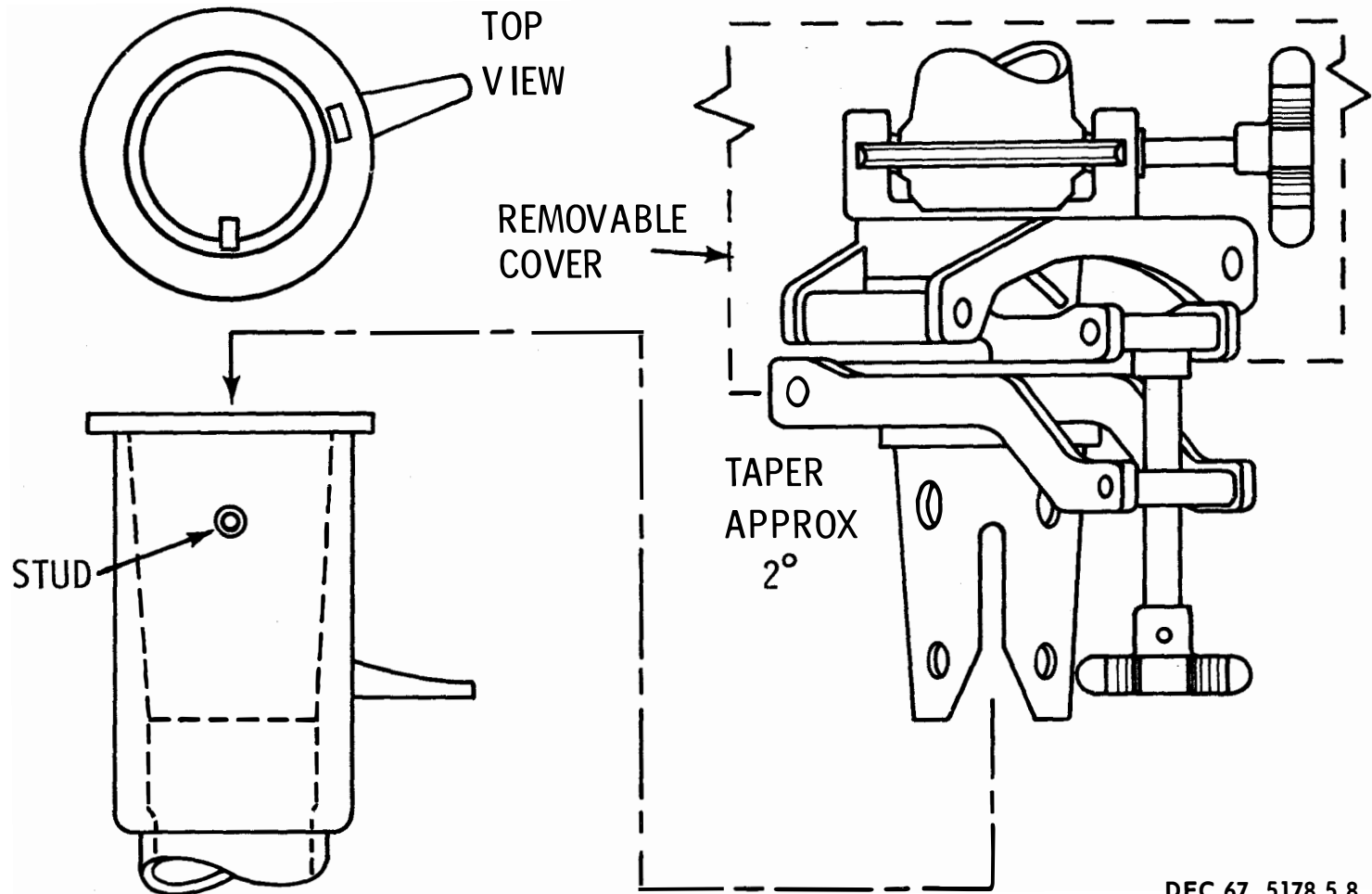

DEC 67 5178.5.8

AIMING MECHANISM/ANTENNA

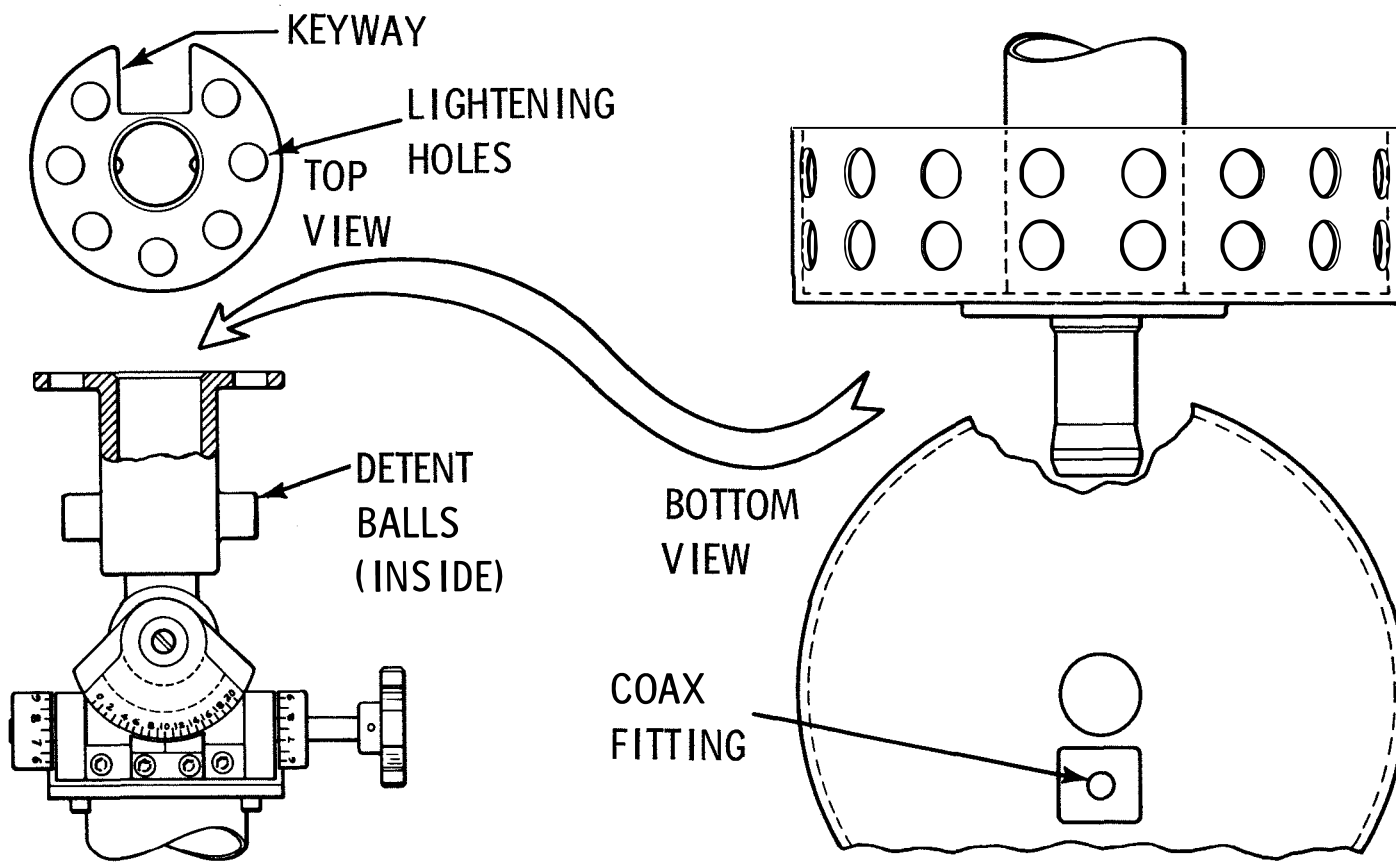

SUNSHIELD TIE-DOWN

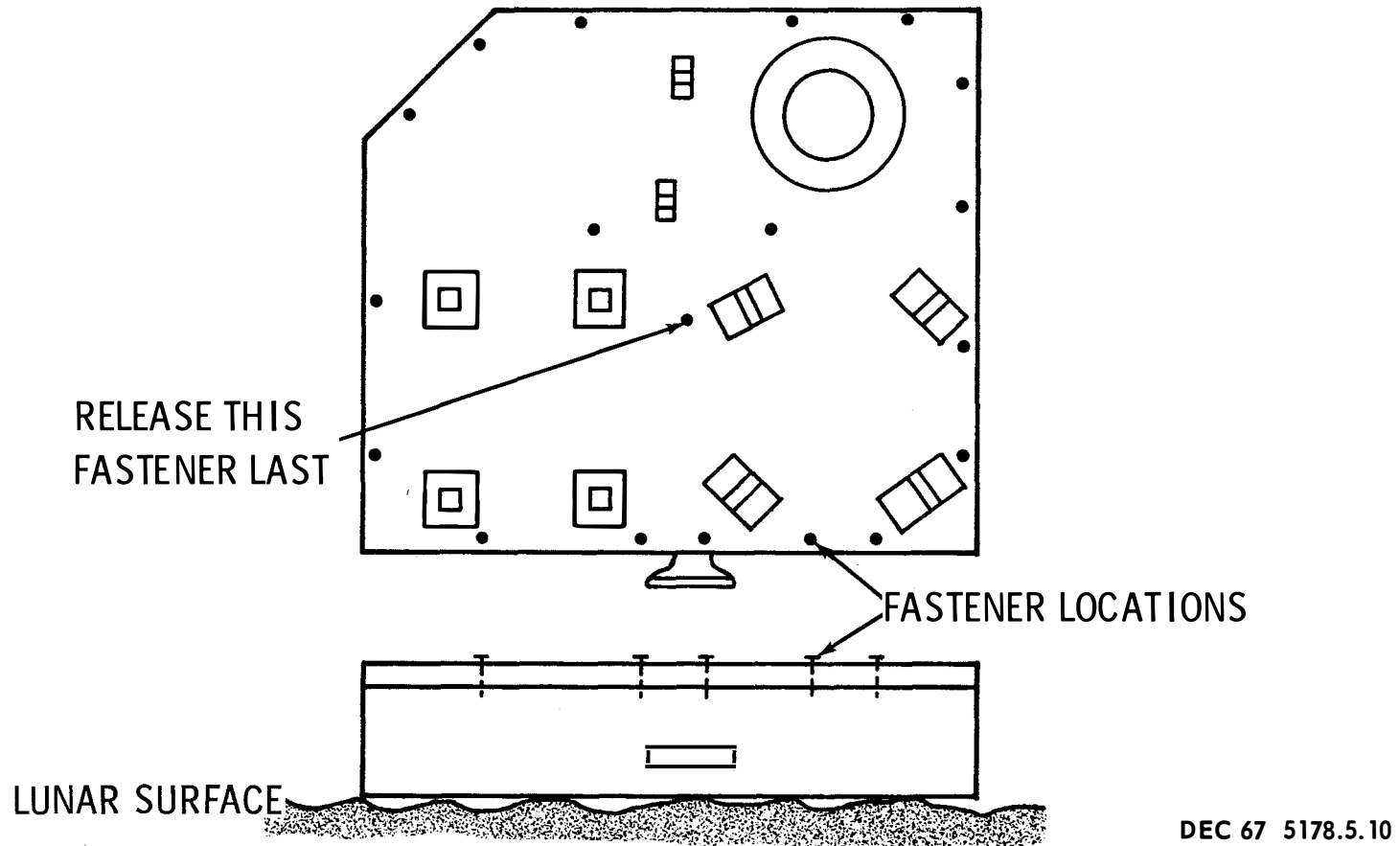

EXTENDERS

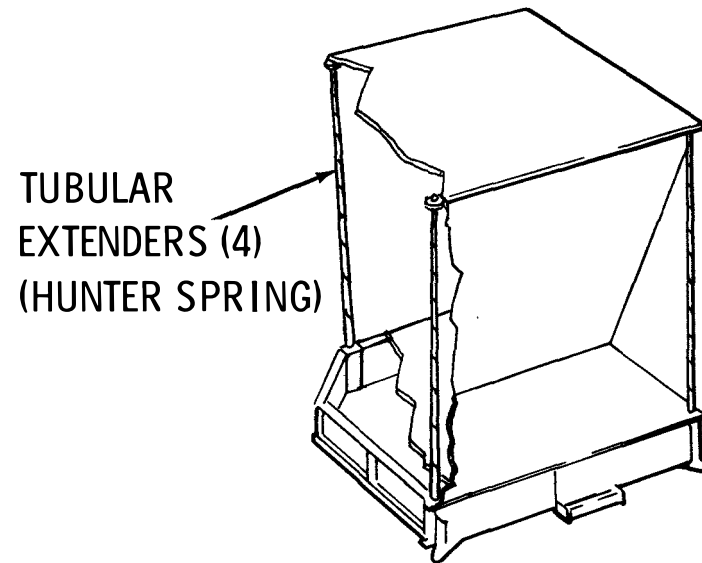

TUBULAR
EXTENDERS (4)
(HUNTER SPRING)

SEPT 68 5178.5.11

SUBPACKAGE 1 EMPLACEMENT CRITERIA

PARAMETER	REQUIREMENT	PRIORITY	INDICATOR	COMMENTS
DISTANCE FROM LM	300 \pm 10 FT	2	MAY HAVE RANGE-FINDER	TRADE OFF OF PLSS CONSTRAINTS AGAINST ASCENT STAGE BLAST*
DIRECTION FROM LM	NOT DUE E OR W	2	EYEBALL	AVOID WALKING INTO SUN OR SHADOW
SITE SELECTION	APPROX HORIZ	1	EYEBALL	AVOID CRATERS AND SLOPES FOR THERMAL AND ANTENNA STABILITY
LEVEL, WRT INDICATOR	ACCEPT LOCAL SLOPE	1	BUBBLE	INTERACTS WITH ALIGNMENT
ALIGN, WRT SHADOW	$\pm 5^\circ$ E-W	1	PARTIAL ROSE (NULL LINE)	THERMAL REQUIREMENT; ROSE ALLOWS 180° ROTATION
SPECIAL REQUIREMENTS	SELECTION OF SITE SHOULD CONSIDER THAT MOST SUBSYSTEMS REQUIRE APPROXIMATELY EQUAL ELEVATIONS FOR CLEAR FIELD OF VIEW (SCIENTIFIC AND THERMAL). * 200 FT DISTANCE GIVES ZERO THEORETICAL SAFETY MARGIN, 300 FT GIVES 100%.			

SEPT 68 5178.5.12

AIMING MECHANISM EMPLACEMENT CRITERIA

PARAMETER	REQUIREMENT	PRIORITY	INDICATOR	COMMENTS
DISTANCE AND DIRECTION	NA	-	-	ATTACHED TO SUBPACKAGE 1
LEVEL, WRT INDICATOR	$\pm 0.55^\circ$ OF VERTICAL	1	BUBBLE	INTERACTS WITH ALIGNMENT
ALIGN, WRT SHADOW	$\pm 0.5^\circ$ E-W	1	NULL LINE	PRECLUDES 180° ROTATION
SPECIAL REQUIREMENTS	NOTE THAT CRITERIA ARE SHOWN FOR BASE OF AIMING MECHANISM; AZIMUTH-ELEVATION GIMBAL SETTINGS ARE FROM SPECIAL TABLES.			

STRUCTURE/THERMAL ALIGNMENT MARKINGS

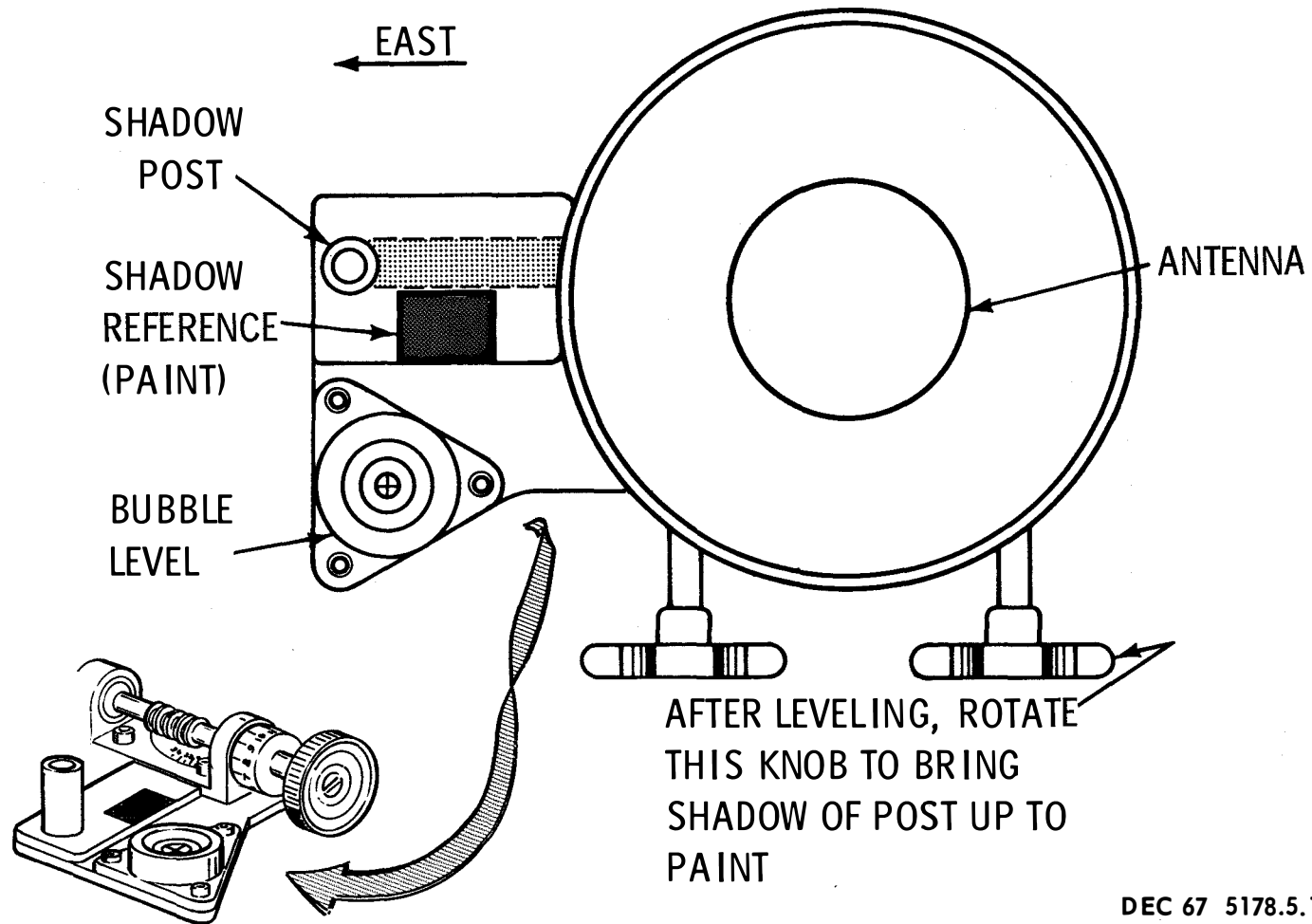

DEC 67 5178.5.14

STRUCTURE/THERMAL TELEMETRY

HK-27	AT-01	SUNSHIELD 1 DEG F	HK-83	AX-01	DUST CELL 1 DEG F
HK-42	AT-02	SUNSHIELD 2 DEG F	HK-30	AX-02	DUST CELL 2 DEG F
HK-04	AT-03	THERM PLT 1 DEG F	HK-56	AX-03	DUST CELL 3 DEG F
HK-28	AT-04	THERM PLT 2 DEG F	HK-84	AX-04	DUST 1 OUT MV/CM2
HK-43	AT-05	THERM PLT 3 DEG F	HK-26	AX-05	DUST 2 OUT MV/CM2
HK-58	AT-06	THERM PLT 4 DEG F	HK-41	AX-06	DUST 3 OUT MV/CM2
HK-71	AT-07	THERM PLT 5 DEG F			
HK-59	AT-08	PRI/ST W1 DEG F			
HK-87	AT-09	PRI/ST W2 DEG F			
HK-15	AT-10	PRI/ST B1 DEG F			
HK-88	AT-11	PRI/ST W3 DEG F *			
HK-60	AT-12	INSUL INT DEG F			
HK-72	AT-13	INSUL EXT DEG F			

ALL PARAMETERS SAMPLED
ONCE PER 54 SEC ALSEP
SEQUENCE

* NOW LOCATED ON POWER DISSIPATION RESISTOR PANEL

STRUCTURE/THERMAL COMMANDS

OCTAL CMD NUMBER

- 027 DUST CELLS ON
CMD 027 IS A ONE-STATE CMD THAT ACTIVATES THE SOLAR CELL
OUTPUTS (3) OF THE DUST DETECTOR
- 031 DUST CELLS OFF
CMD 031 IS A ONE-STATE CMD THAT DEACTIVATES THE SOLAR CELL
OUTPUTS (3) OF THE DUST DETECTOR

NOTE THAT THERE IS EQUAL PROBABILITY OF THE DUST CELLS BEING
ON OR OFF WHEN ALSEP STARTS UP INITIALLY ON THE LUNAR SURFACE
- 055 DSS HTR 1 SEL
CMD 055 ACTUATES RELAY K-14 IN THE PDU APPLYING +29 VDC TO THE
10-WATT HTR IN THE CENT STA AND REMOVING +29VDC FROM THE 5-WATT HTR
- 056 DSS HTR 2 SEL
CMD 056 ACTUATES RELAYS K-14 AND K-15 IN THE PDU APPLYING +29VDC
TO THE 5-WATT HTR IN THE CENT STA AND REMOVING +29VDC FROM THE
10-WATT HTR
- 057 DSS HTR 2 OFF
CMD 057 ACTUATES RELAY K-15 IN THE PDU REMOVING +29 VDC FROM THE
5-WATT HTR IN THE CENT STA. IF THE 10-WATT HTR IS ON, TRANSMISSION
OF THIS CMD WILL HAVE NO EFFECT
- 024 DSS HTR 3 ON
CMD 024 ACTUATES RELAY K-18 IN THE PDU APPLYING +29 VDC TO THE
THERMOSTATICALLY-CONTROLLED 10-WATT HTR IN THE CENT STA
- 025 DSS HTR 3 OFF
CMD 025 ACTUATES RELAY K-18 IN THE PDU REMOVING +29 VDC FROM THE
THERMOSTATICALLY-CONTROLLED 10-WATT HTR IN THE CENT STA

APR 69 5178.5.16

ELECTRICAL POWER SUBSYSTEM

- RADIOISOTOPE THERMOELECTRIC GENERATOR
 - COMPONENTS
 - PERFORMANCE
 - KEY FEATURES
- FUEL TRANSFER AND RTG DEPLOYMENT
- POWER CONDITIONING UNIT
 - FUNCTIONS AND PERFORMANCE
 - POWER/THERMAL INTERACTIONS
- COMMANDS AND DATA

NOV 68 5178.6.1

POWER GENERATING FUNCTION

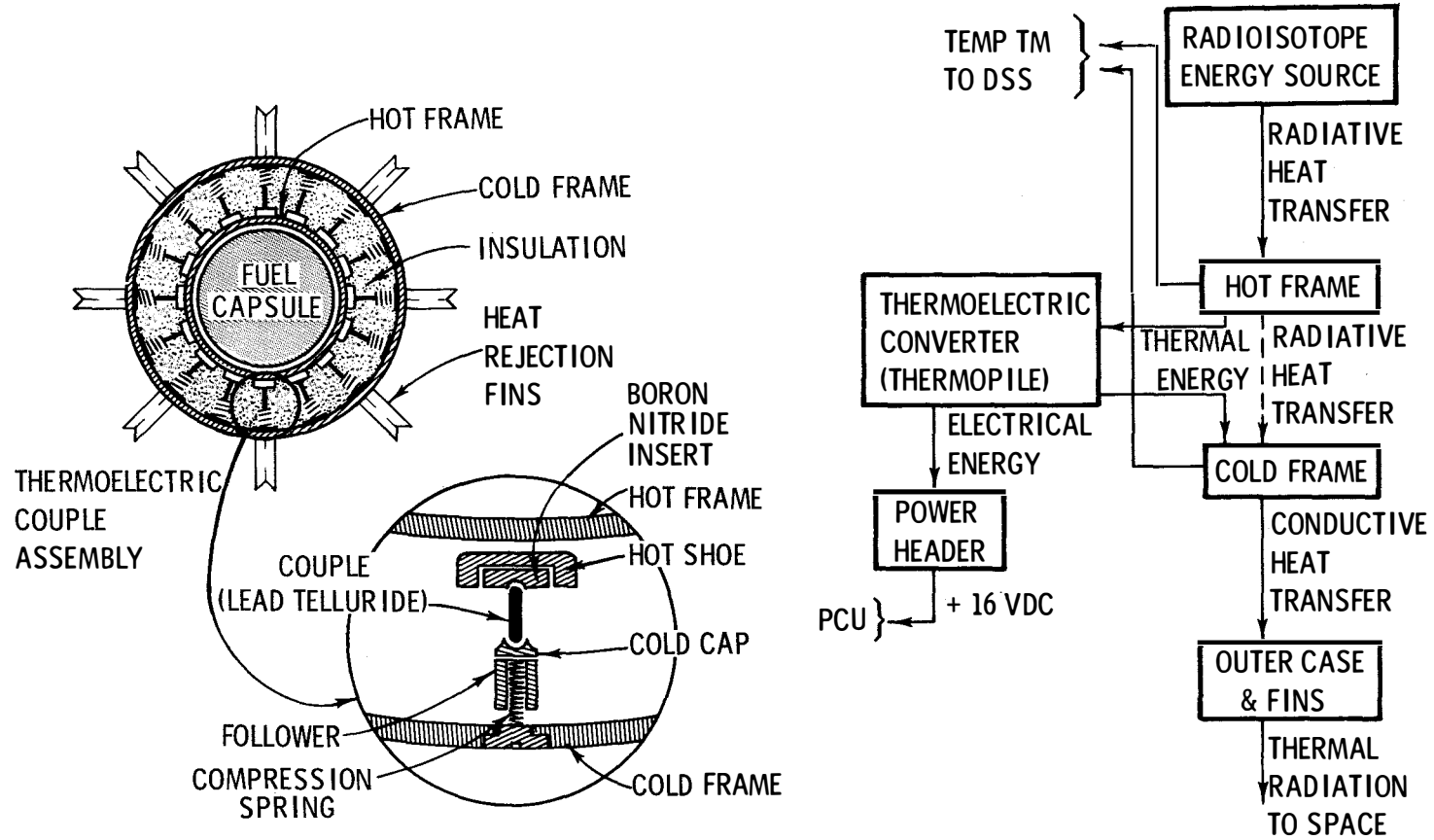

NOV 68 5178.6.2

RTG PERFORMANCE

OUTPUT POWER: 56.2 W (ONE YR) AND UP TO 74 W

OUTPUT VOLTAGE: 16 VDC (NOMINAL)

CURRENT: 4 AMP (APPROX)

OVERALL EFFICIENCY: 4 % (APPROX)

HOT JUNCTION TEMP: 1100° F* (MAX)

COLD JUNCTION TEMP: 600° F* (MAX)

FUEL CAPSULE THERMAL OUTPUT: 1430 TO 1520 W

FUEL CLAD TEMP: 1390° F (MAX)

* LUNAR DAY (NIGHT PERF NEARLY SAME)

RTG DAY/NIGHT EFFECTS

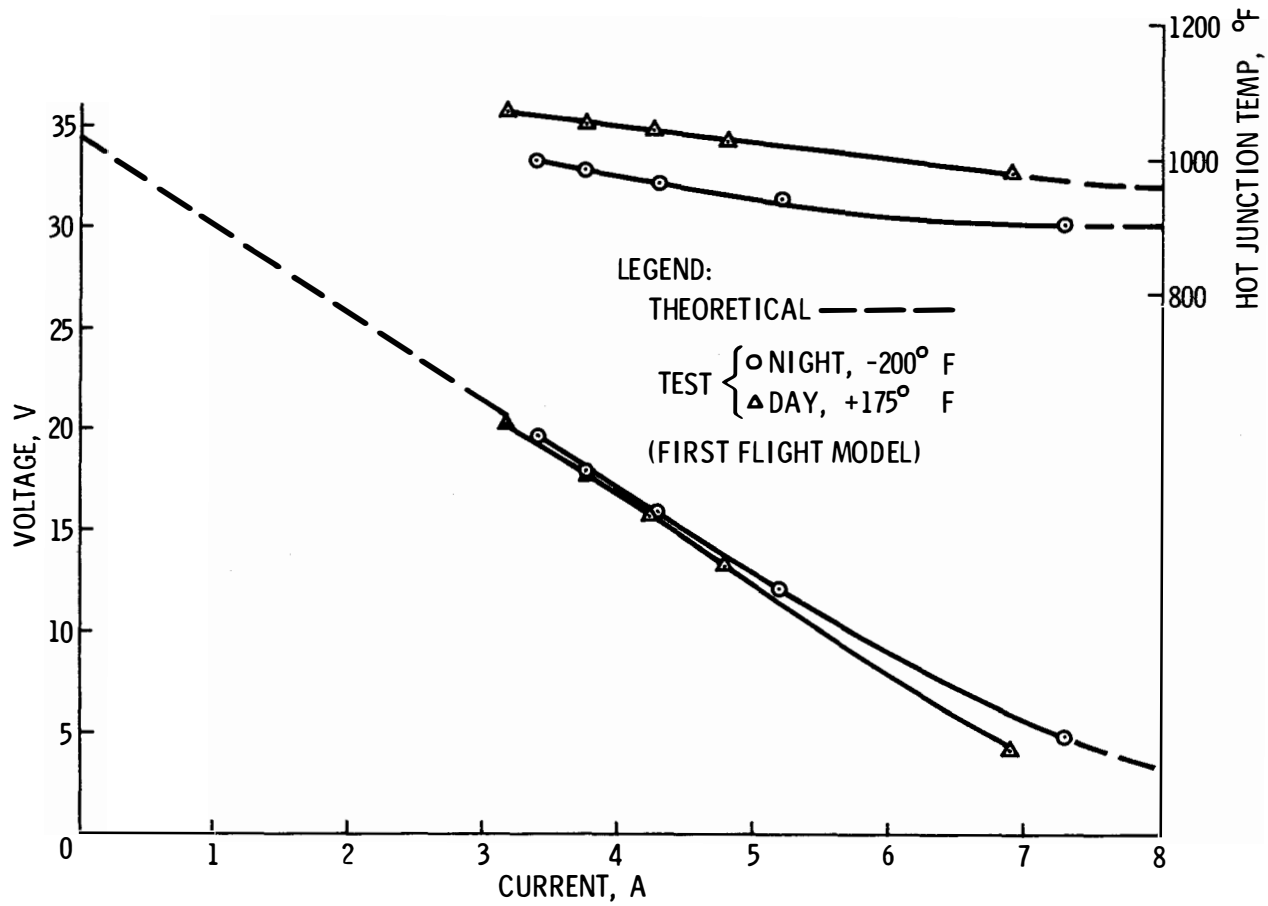

JAN 68 5178.6.4

RTG SUBASSEMBLIES

- THERMOPILE
 - COUPLES, PLUS HOT SHOES, ETC.
 - SPRING LOADED TO KEEP THE THERMOELECTRIC ELEMENTS IN COMPRESSIVE LOADING
- HERMETIC SEAL
 - FORWARD (TOP) SEAL SECURES HOT FRAME TO OUTER CASE
 - AFT (BOTTOM) SEAL PROVIDES END COVER FOR OUTER CASE
 - POWER LEADS ENTER THROUGH AFT SEAL
- STRUCTURE AND HEAT REJECTION
 - CONTAIN AND SUPPORT OTHER EQUIPMENT
 - DISTRIBUTE THERMAL ENERGY (PRIMARILY IN RADIAL DIRECTION)
- WIRING
 - SERIES-PARALLEL ARRANGEMENT OF THERMOELECTRIC ELEMENTS
 - FIELD CANCELLATION COILS AT EACH END OF GENERATOR LIMIT CURRENT-INDUCED MAGNETIC FIELD INTENSITY TO 0.24 GAMMAS AT ONE METER, ALONG AXIAL CENTERLINE

JAN 68 5178.6.5

RTG FUEL CASK

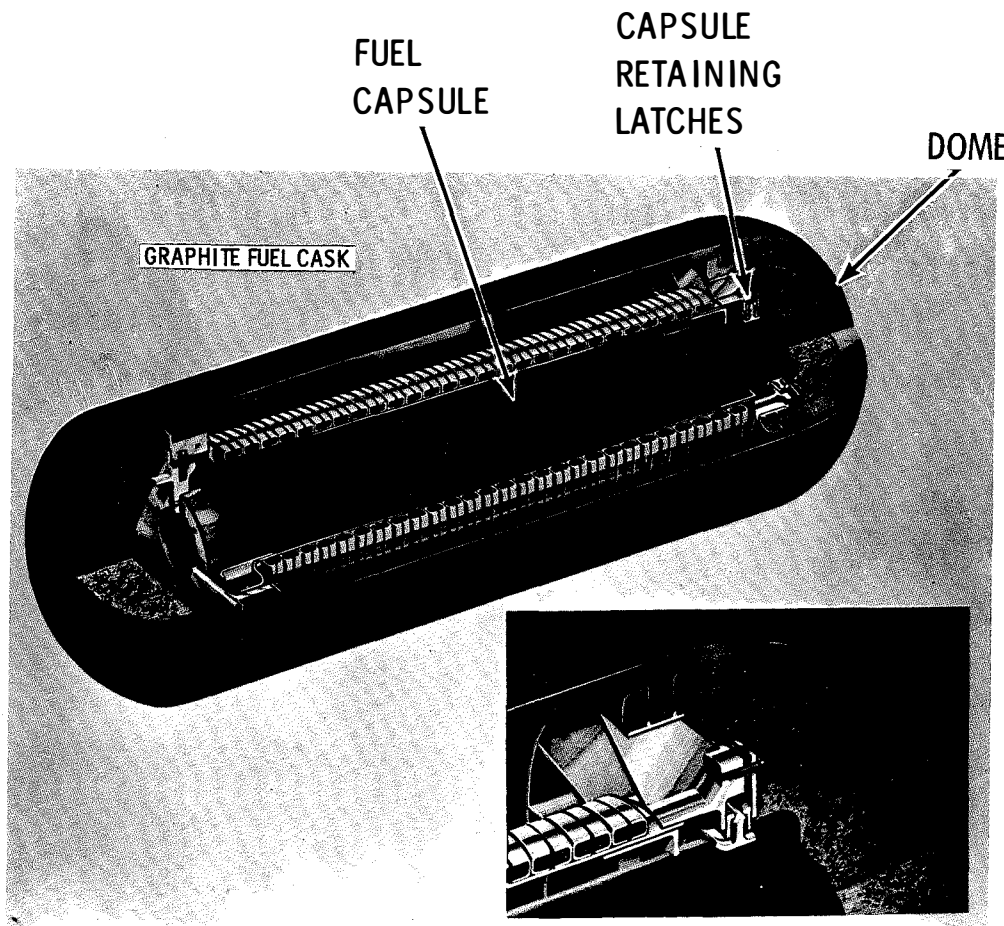

- CONSTRUCTED PRIMARILY OF GRAPHITE
- CONTAINS FUEL CAPSULE DURING TRANSLUNAR FLIGHT
- PROVIDES REENTRY PROTECTION IN CASE OF ORBITAL ABORT
- PROVIDES FREE RADIATION SURFACE FOR CAPSULE HEAT REJECTION
- MOUNTED ON LM EXTERIOR

JAN 68 5178.6.6

RTG FUEL TRANSFER

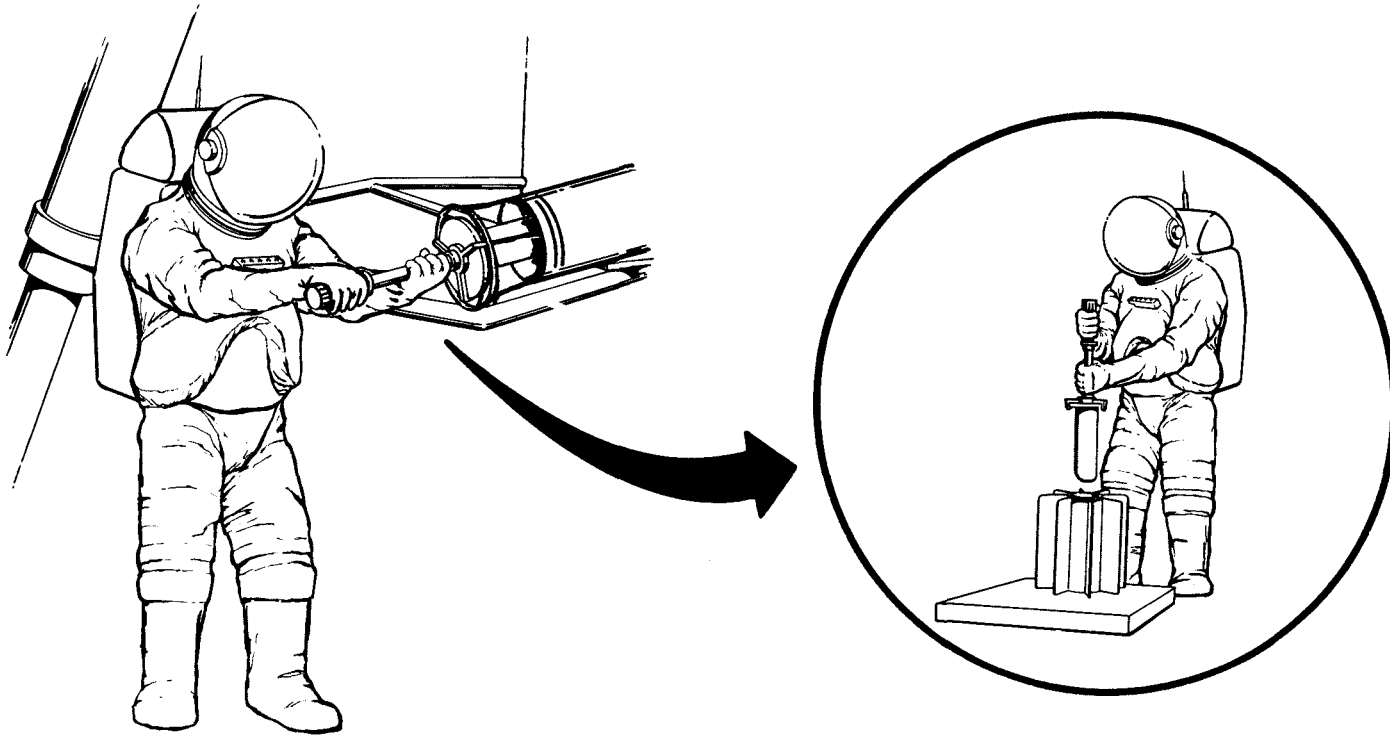

APR 69 5178.6.7

RTG EMPLACEMENT CRITERIA

PARAMETER	REQUIREMENT	PRIORITY	INDICATOR	COMMENTS
DISTANCE FROM SUBPACKAGE 1	11 ± 1 ft	2	12 ft CABLE	ASTRONAUT SAFETY AND MAXIMUM VIEW OF SPACE
DIRECTION FROM SUBPACKAGE 1	DUE E OR W	1	EYEBALL	MINIMIZE THERMAL LOAD ON SUBPACKAGE 1
SITE SELECTION	APPROX HORIZ	1	EYEBALL	AVOID CRATERS AND SLOPES FOR THERMAL REASONS
LEVEL	$\pm 5^\circ$ OF VERTICAL	1	EYEBALL	THERMAL REASONS
ALIGN	NONE	3	-	FAVOR CABLE EXIT
SPECIAL REQUIREMENTS	RTG NEEDS APPROXIMATELY HEMISPHERE VIEW OF SPACE FOR THERMAL REASONS; NO EXPERIMENT WILL BE WITHIN 10 FT DUE TO THEIR OWN REQUIREMENTS.			

JAN 68 5178.6.8

POWER DISTRIBUTION UNIT

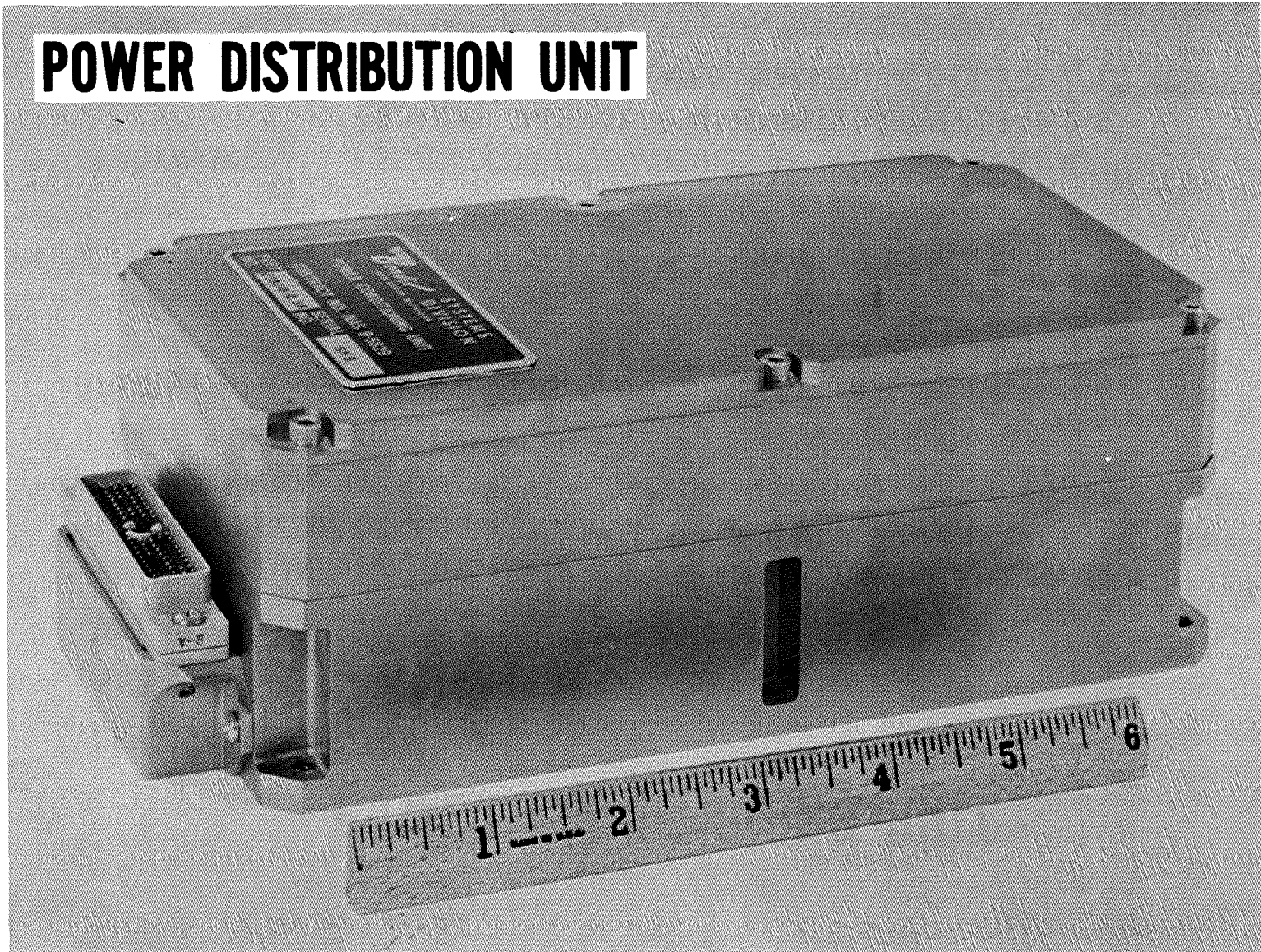

JAN 68 5178.6.9

POWER CONDITIONING UNIT

PHYSICAL DESCRIPTION

SIZE - 8.36 X 4.14 X 2.94 IN.

WEIGHT - 4.5 POUNDS

POWER - THE INTERNAL DISSIPATION OF THE POWER CONDITIONING UNIT (PCU) DEPENDS ON THE INPUT POWER, THE OUTPUT POWER AND THE REGULATOR RANGE. TYPICAL INTERNAL DISSIPATION CURVES ARE SHOWN IN FOLLOWING INFORMATION.

PARTS COUNT	-	TRANSISTORS	27	RELAY	1
		DIODES	44	THERMISTORS	4
		ZENER DIODES	4	INDUCTORS	11
		CAPACITORS	71	TRANSFORMERS	8
		RESISTORS	87		

PACKAGING - SEVEN CORDWOOD MODULES ARE MOUNTED ON A 'MOTHER BOARD'. THERMAL REQUIREMENTS ARE MET BY USING MACHINED, GOLD-PLATED, MAGNESIUM CASES FOR THE MODULES.

CONNECTOR - HUGHES - 88 PIN

JAN 68 5178.6.10

PCU FEATURES

- * CONSISTS OF REDUNDANT POWER CONDITIONERS WITH BOTH AUTOMATIC AND COMMANDABLE SELECTION OF THE STANDBY SECTION. OVER/UNDER VOLTAGES ARE SENSED FOR AUTOMATIC SWITCHING FROM PCU#1 TO PCU#2.
- * PROVIDES 6 REGULATED DC OUTPUT VOLTAGES WITH NOMINAL VALUES OF +29, +15, +12, +5, -6, AND -12 VOLTS.
- * CONTAINS FILTERS TO LIMIT OUTPUT RIPPLE VOLTAGE TO BE APPROXIMATELY 150 MILLIVOLTS PEAK-TO-PEAK.
- * OPERATES AT AN EFFICIENCY OF ABOUT 85% WITH A 48 WATT LOAD.
- * HAS 'HOLD-OFF' CIRCUIT ON PC#1 TO PREVENT STARTING UNTIL RTG POWER IS SUFFICIENT TO PERMIT PCU OPERATION WITH REGULATION.
- * TO MAINTAIN THE RTG TEMPERATURE WITHIN SAFE LIMITS, THE PCU HOLDS THE RTG LOAD AT A (RELATIVELY) CONSTANT VALUE.
- * PROVIDES TM SIGNALS FOR MONITORING RTG CURRENT, RTG VOLTAGE, SHUNT REGULATOR CURRENT AND TEMPERATURES.
- * PROVIDES RESERVE POWER REFERENCE AND RESERVE POWER LEVEL SIGNALS TO RIPPLE-OFF CIRCUITS IN THE PDU.

JAN 68 5178.6.11

SIMPLIFIED BLOCK DIAGRAM - PCU

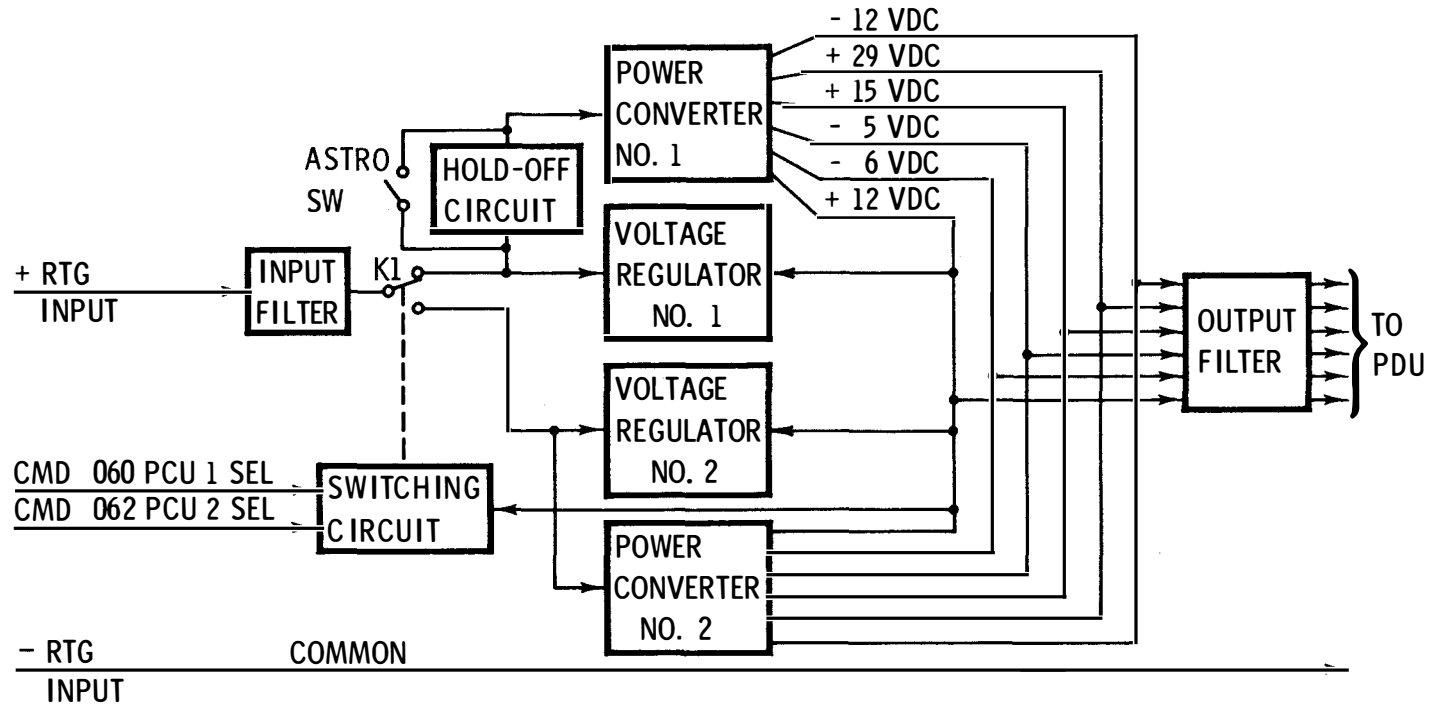

PCU 1 DIAGRAM

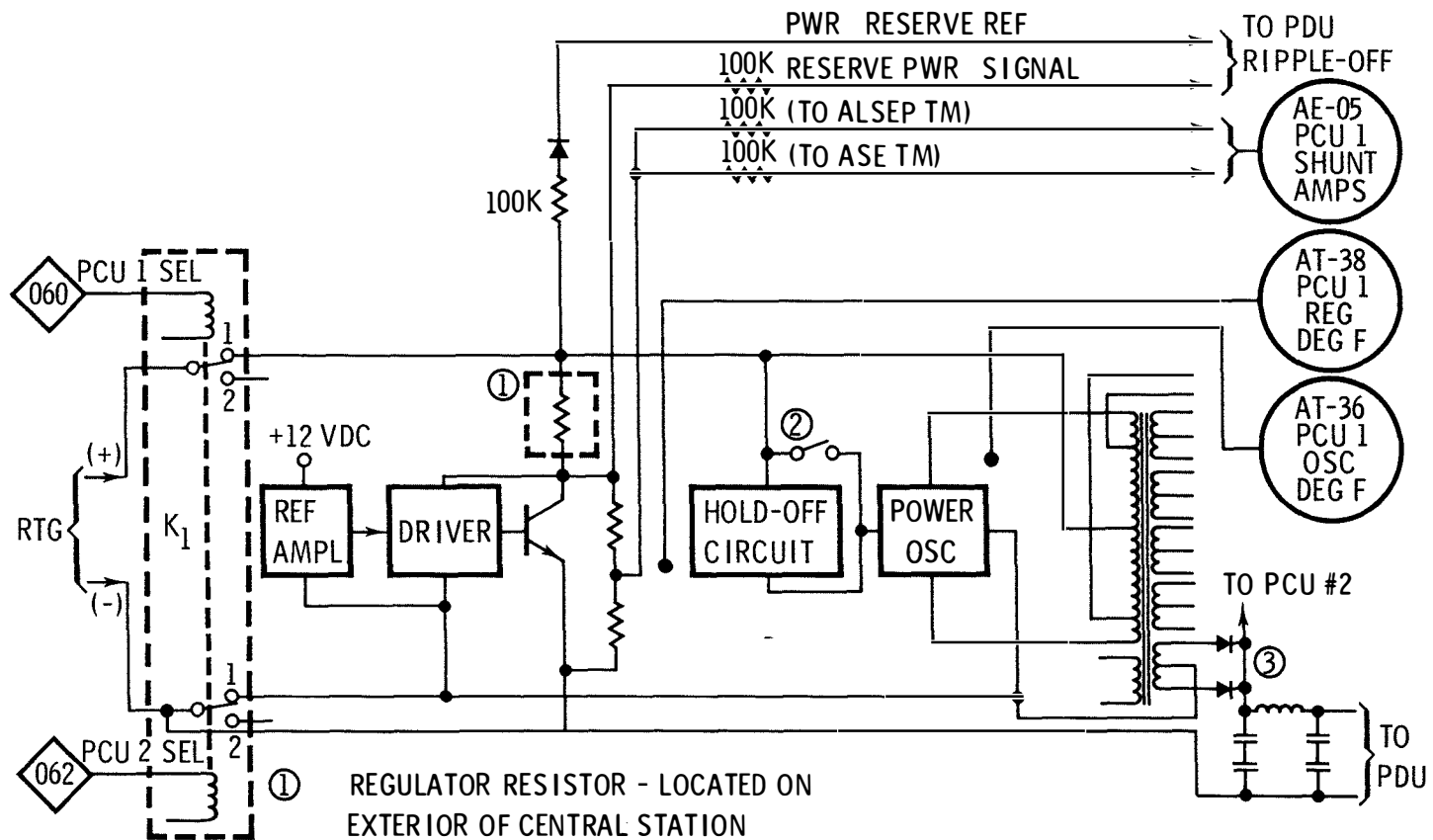

- ① REGULATOR RESISTOR - LOCATED ON EXTERIOR OF CENTRAL STATION
- ② HOLD-OFF CIRCUIT ON PCU #1 ONLY. SWITCH IS ASTRONAUT SWITCH S-1
- ③ TYPICAL (1 OF 6) RECTIFIER/FILTER CIRCUIT. FILTER IS COMMON TO BOTH PCU #1 & PCU #2.

NOV 68 5178.6.13

RTG CURRENT AND VOLTAGE TM

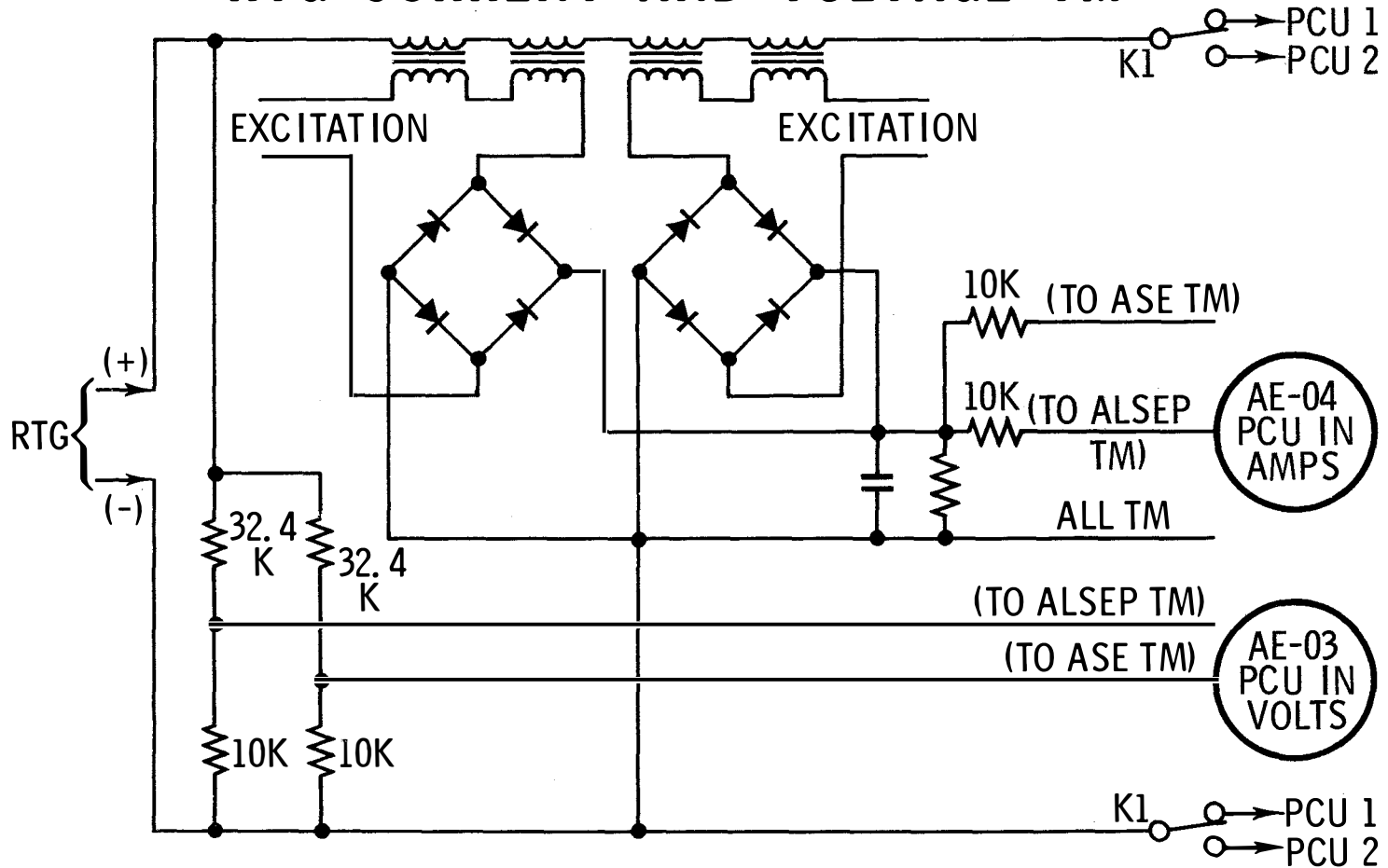

NOV 68 5178.6.14

PCU SELECTION FUNCTION

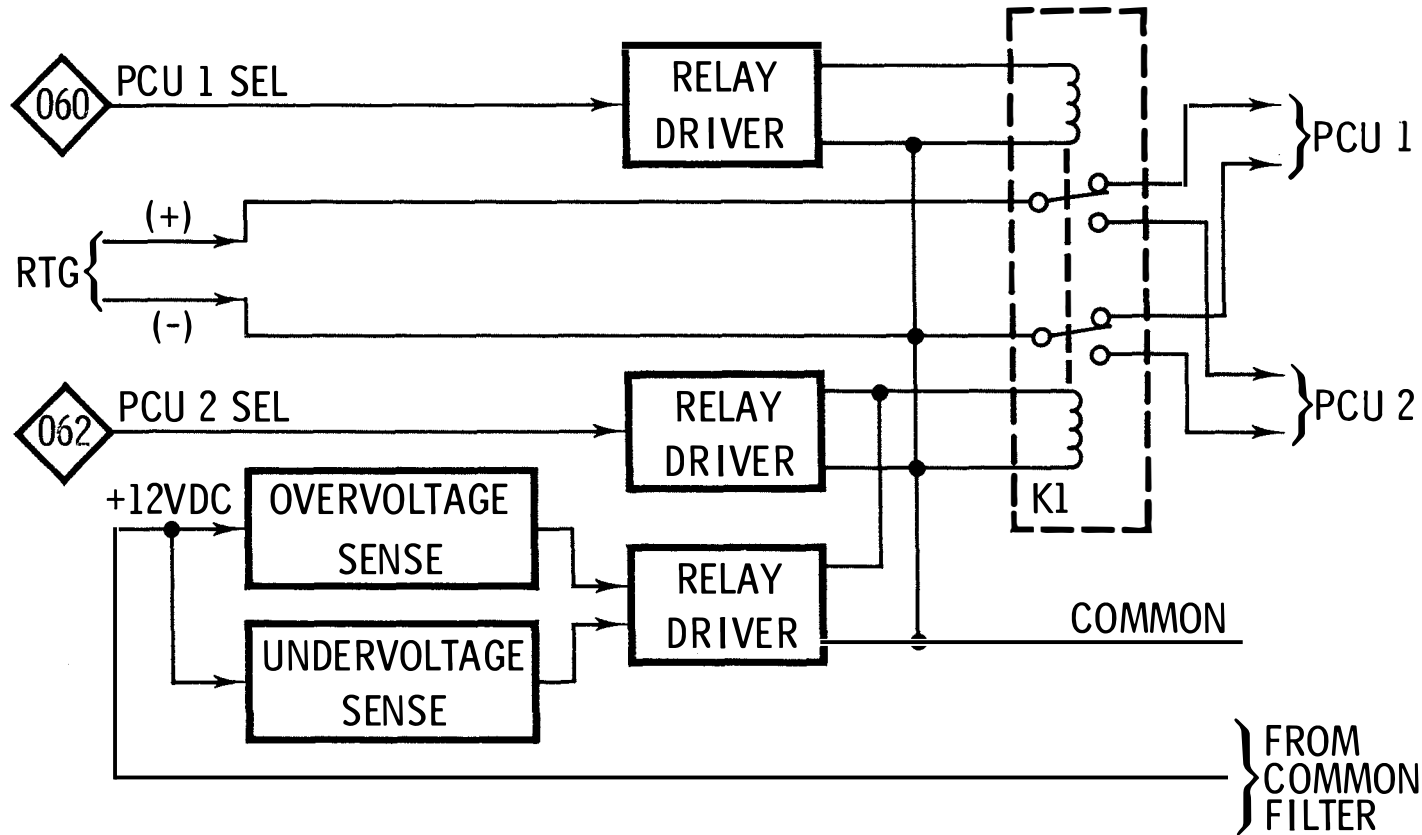

PCU POWER/THERMAL RELATIONSHIP

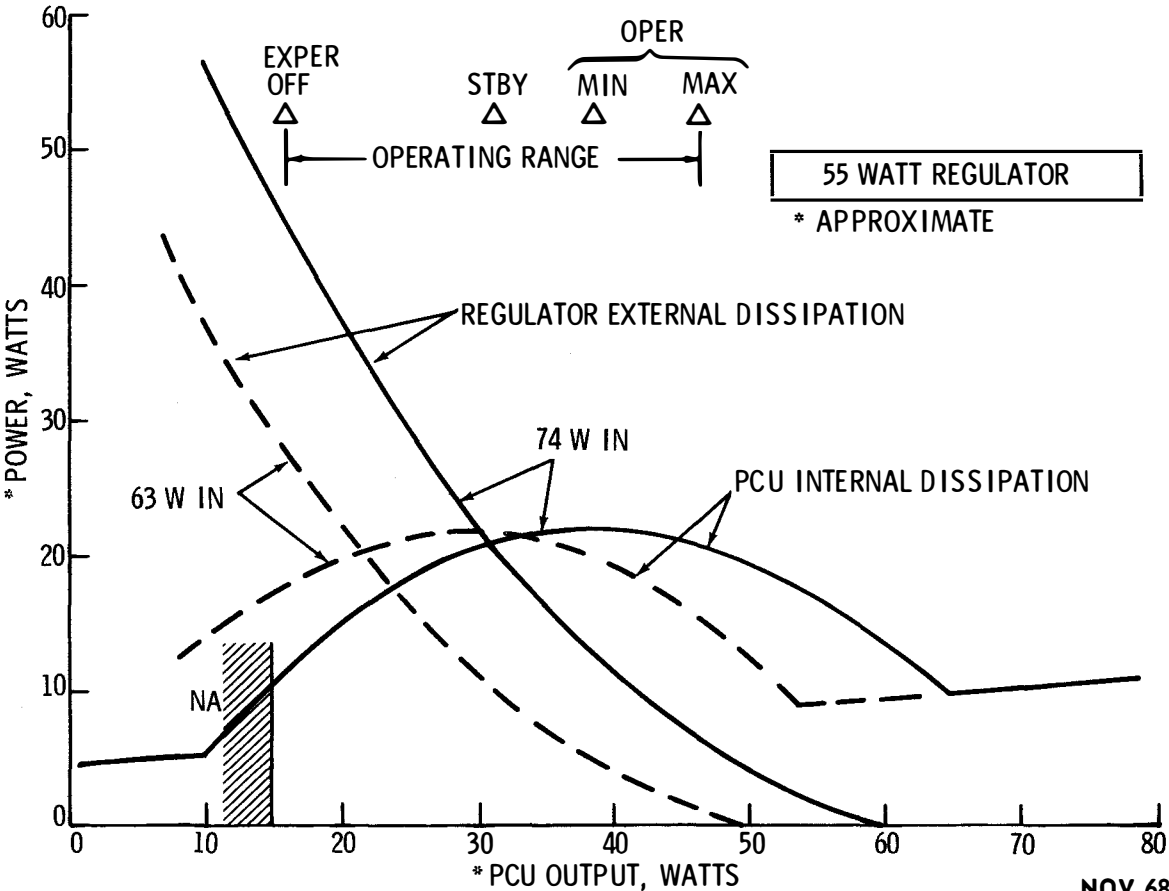

EPS DATA

FROM RTG

AR-01 HOT FRAME 1 DEG F
AR-02 HOT FRAME 2 DEG F
AR-03 HOT FRAME 3 DEG F
AR-04 CLD FRAME 1 DEG F
AR-05 CLD FRAME 2 DEG F
AR-06 CLD FRAME 3 DEG F

FROM PCU

AT-36 PCU 1 OSC DEG F
AT-37 PCU 2 OSC DEG F
AT-38 PCU 1 REG DEG F
AT-39 PCU 2 REG DEG F
AE-03 PCU IN VOLTS
AE-04 PCU IN AMPS
AE-05 PCU 1 SHUNT AMPS
AE-06 PCU 2 SHUNT AMPS

FROM PDU

AE-07 PCU + 29V OUT
AE-08 PCU + 15V OUT
AE-09 PCU + 12V OUT
AE-10 PCU + 5V OUT
AE-11 PCU - 12V OUT
AE-12 PCU - 6V OUT

EPS COMMANDS

OCTAL CMD NUMBERS

●017 DISSIP R1 ON

THIS CMD ACTUATES RELAY K-16, IN THE PDU, TO THE POSITION THAT APPLIES +29 VDC TO A 7-WATT POWER DISSIPATION RESISTOR, AND IS USED TO OPTIMIZE THE LOAD ON THE PCU.

●021 DISSIP R1 OFF

THIS CMD ACTUATES RELAY K-16, IN THE PDU, TO THE POSITION THAT REMOVES +29 VDC FROM THE 7-WATT POWER DISSIPATION RESISTOR.

●022 DISSIP R2 ON

THIS CMD ACTUATES RELAY K-17, IN THE PDU, TO THE POSITION THAT APPLIES +29 VDC TO A 14-WATT POWER DISSIPATION RESISTOR, AND IS USED TO OPTIMIZE THE LOAD ON THE PCU.

●023 DISSIP R2 OFF

THIS CMD ACTUATES RELAY K-17, IN THE PDU, TO THE POSITION THAT REMOVES +29 VDC FROM THE 14-WATT POWER DISSIPATION RESISTOR.

●060 PCU 1 SEL

THIS CMD ACTUATES RELAY K-01, IN THE PCU, WHICH APPLIES +16 VDC FROM THE RTG TO PCU 1 AND SIMULTANEOUSLY DEENERGIZES PCU 2. PCU 1 IS PRESET TO BE ENERGIZED AT INITIAL LUNAR ACTIVATION. NOTE THAT THERE IS AN AUTOMATIC SWITCH-OVER FEATURE TO PCU 2 IN THE EVENT THE +12 VDC BUS VARIES MORE THAN +1 VDC. ADDING OR REMOVING ELECTRICAL LOADS (VIA GROUND COMMANDS) ON PCU 1 CAN PREVENT THE +12 VDC BUS FROM VARYING OUT OF LIMITS. IN THE EVENT AUTOMATIC SWITCH-OVER TO PCU 2 HAS OCCURRED, THIS COMMAND MUST BE FLAGGED AS HIGHLY CRITICAL. THE CAUSE OF THE SWITCH-OVER MUST BE DETERMINED BEFORE THIS COMMAND IS EXECUTED.

●062 PCU 2 SEL

THIS CMD ACTUATES RELAY K-01, IN THE PCU, WHICH APPLIES +16 VDC FROM THE RTG TO PCU 2 AND SIMULTANEOUSLY DEENERGIZES PCU 1. NOTE THAT AT THE TIME OF LUNAR ACTIVATION, PCU 2 IS DEENERGIZED, WITH NO MEANS TO DETERMINE ITS CONDITION. FURTHER NOTE THAT THERE IS NO AUTOMATIC SWITCH-OVER FROM PCU 2 TO PCU 1. THIS SITUATION, THEREFORE, MAKES THIS COMMAND HIGHLY CRITICAL. THIS COMMAND SHOULD BE EXECUTED ONLY AFTER DETERMINING THAT PCU 1 IS ON THE VERGE OF FAILING.

COMMAND AND TELEMETRY LINKS

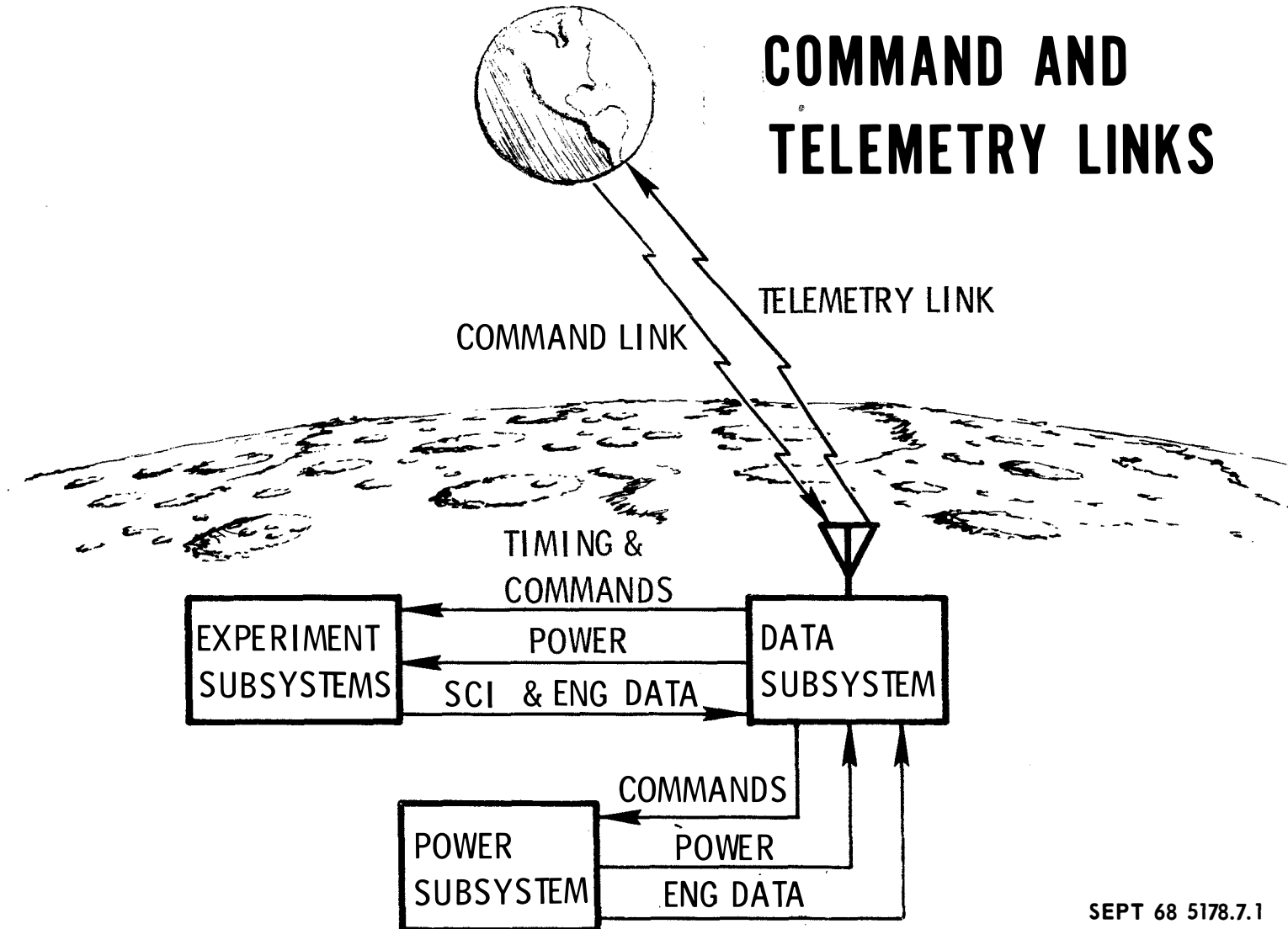

SEPT 68 5178.7.1

CENTRAL STATION DEPLOYED CONFIGURATION

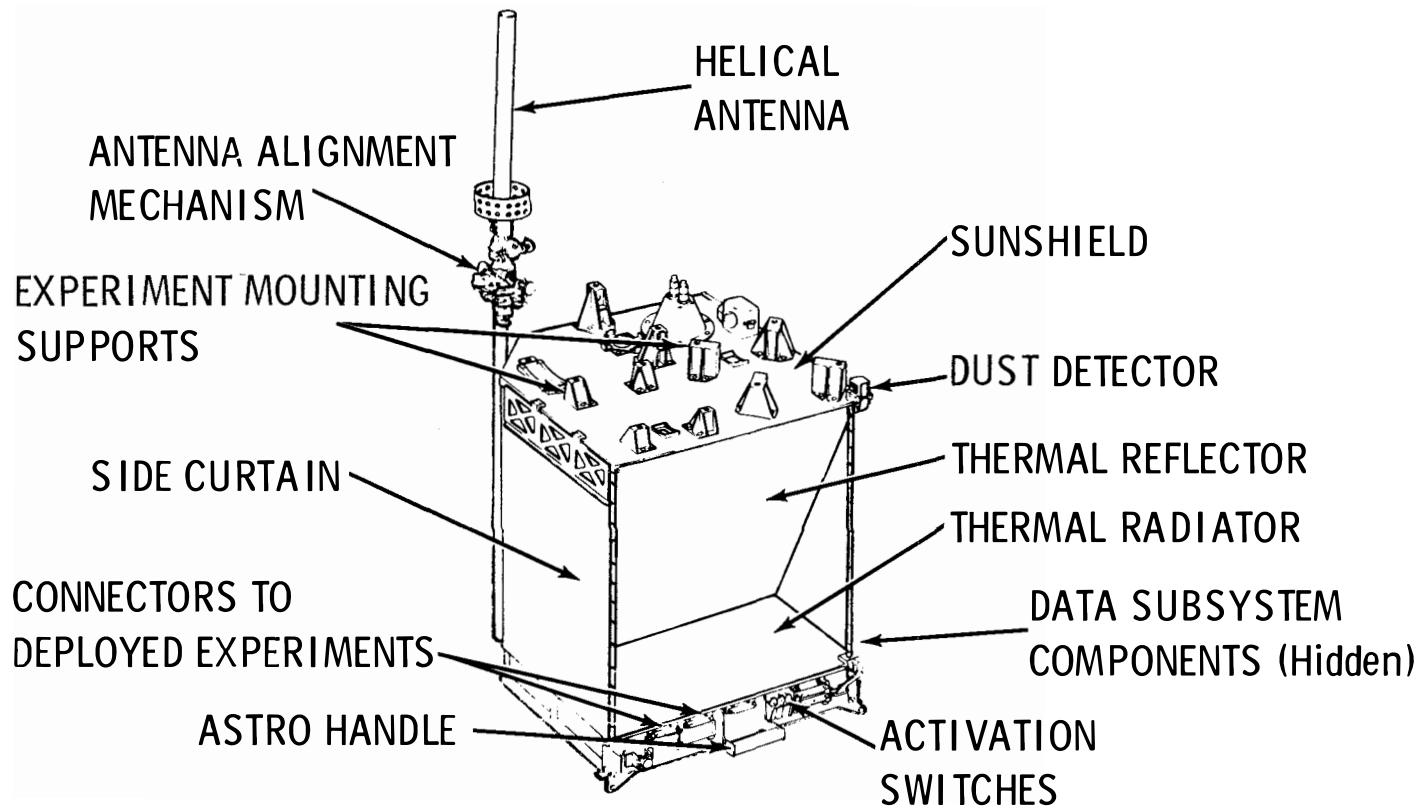

APR 69 5178.7.2

CENTRAL STATION DATA SUBSYSTEM COMPONENTS

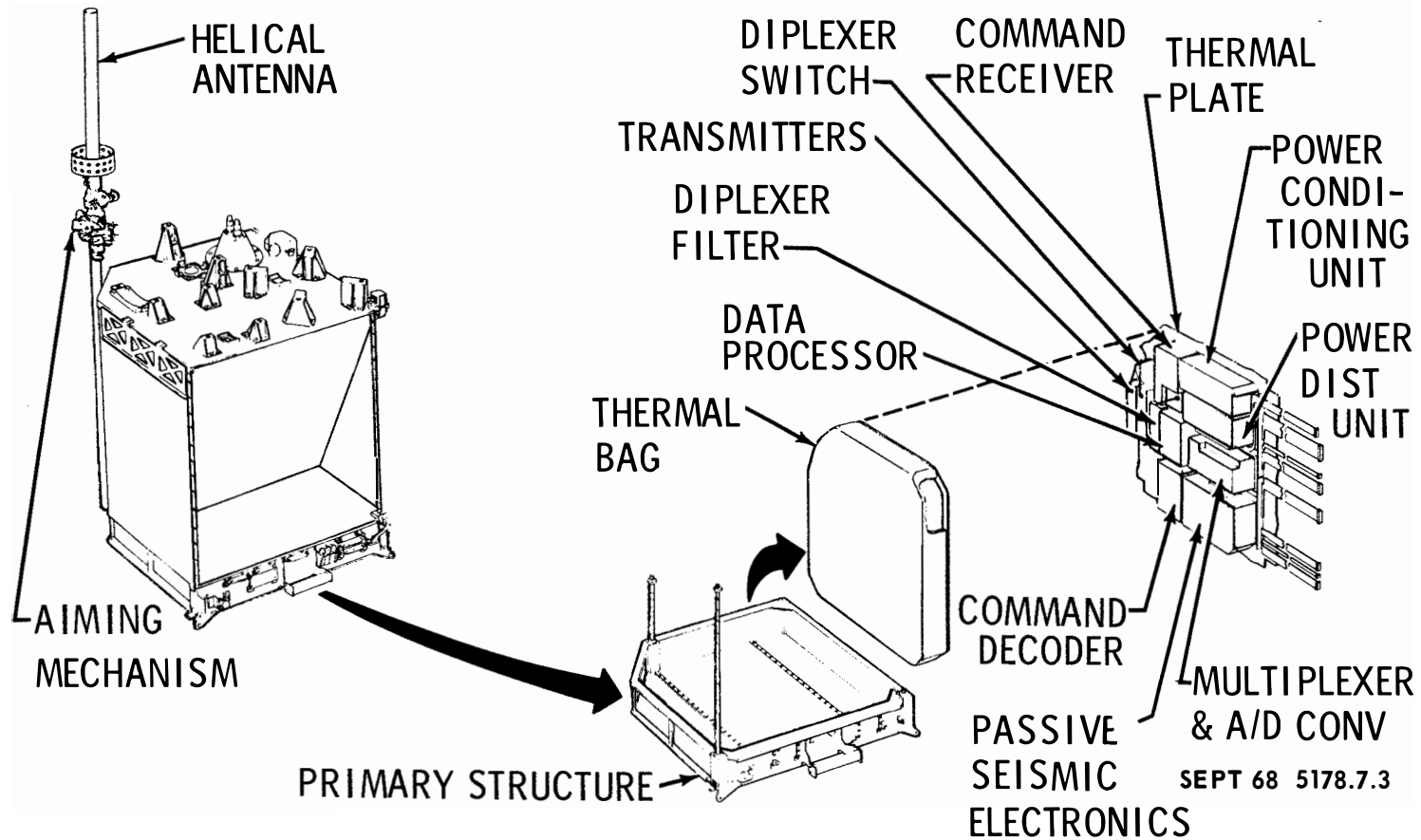

CENTRAL STATION SENSORS AND HEATERS

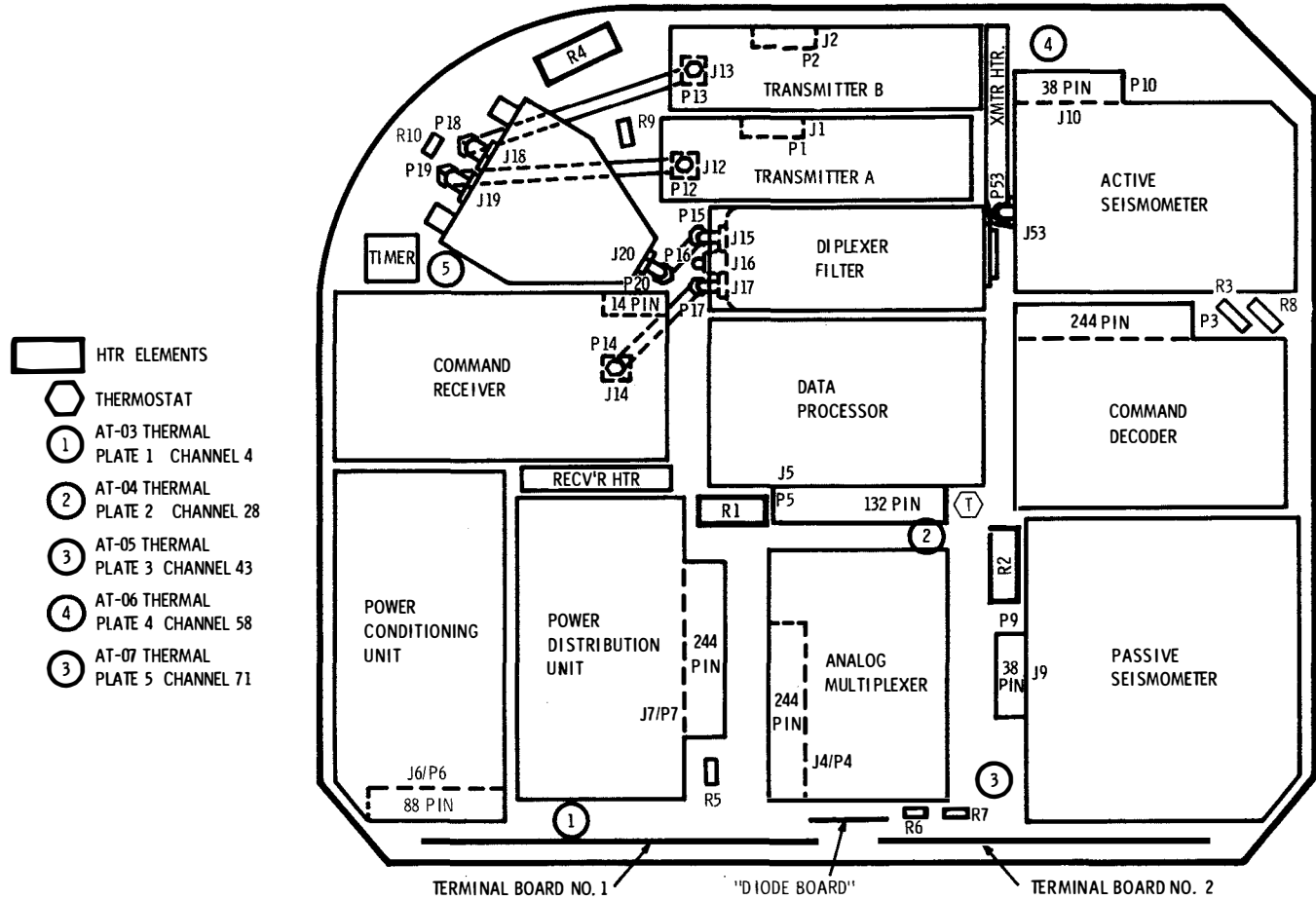

SEPT 68 5178.7.4

CENTRAL STATION LAYOUT

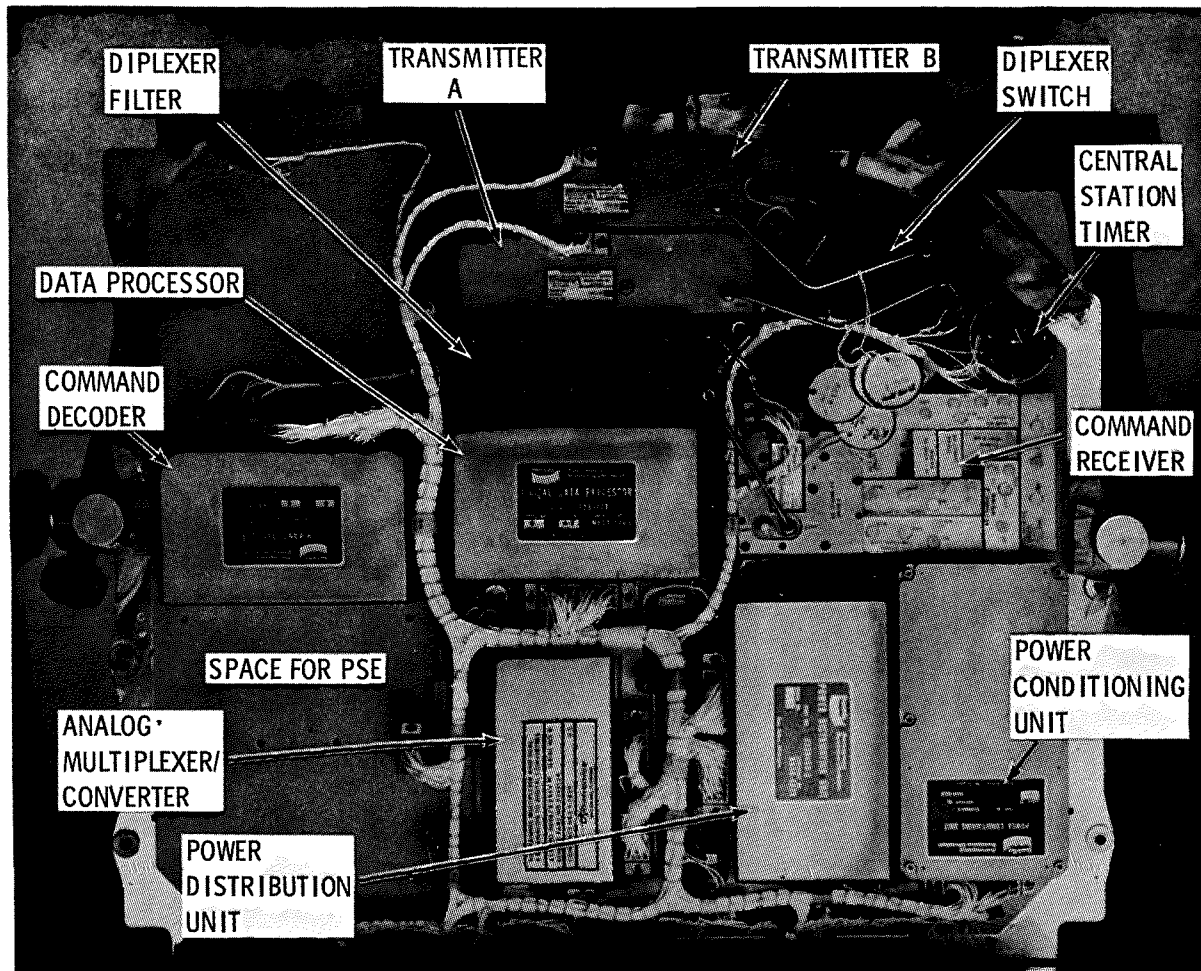

NOV 68 5178.7.5

DATA SUBSYSTEM HARDWARE

ITEM	FUNCTION
(A) POWER DISTRIBUTION & SIGNAL CONDITIONER	CONTROL OF POWER SWITCHING AS COMMANDED AND CONDITIONING OF ENGINEERING STATUS DATA
(B) COMMAND DECODER	DECODE RECEIVED SIGNAL & ISSUE COMMANDS TO THE SYSTEM
(C) DATA PROCESSOR	COLLECT AND FORMAT SCIENTIFIC OUTPUTS FROM THE EXPERIMENTS. COLLECT AND CONVERT ANALOG HOUSEKEEPING DATA INTO DIGITAL FORM
(D) COMMAND RECEIVER	ACCEPT THE EARTH-TO-MOON UPLINK SIGNAL
(E) TRANSMITTER	GENERATE MOON-TO-EARTH DOWNLINK SIGNAL
(F) DI PLEXER SWITCH	CONNECT EITHER TRANSMITTER TO THE ANTENNA
(G) DIPLEXER FILTER	CONNECT RECEIVER INPUT AND TRANSMITTER OUTPUT TO THE ANTENNA WITH REQUIRED RECEIVER/ TRANSMITTER ISOLATION
(H) CENTRAL STATION TIMER	PROVIDE AUTOMATIC ACTIVATION FEATURES (AS A BACK-UP) AND SWITCH OFF TRANSMITTERS AFTER 2 YEARS
(I) ANTENNA	RECEIVE AND RADIATE UP-AND-DOWN LINK RF SIGNALS
(J) ANTENNA AIMING MECHANISM	MEANS OF ADJUSTMENT FOR DIRECTING ANTENNA TO EARTH
(K) MISCELLANEOUS- COMPRISING:-	
i. CENTRAL STATION HEATERS	MAINTAIN TEMPERATURE DURING LUNAR NIGHT.
ii. ASTRONAUT SWITCHES	PROVIDE A BACK-UP FEATURE FOR LOCAL ALSEP ACTIVATION
iii. TEMPERATURE SENSORS	SUPPLY TEMPERATURE DATA OF SELECTED POINTS AROUND THE CENTRAL STATION

NOV 67 5178.7.6

DATA SUBSYSTEM BLOCK DIAGRAM

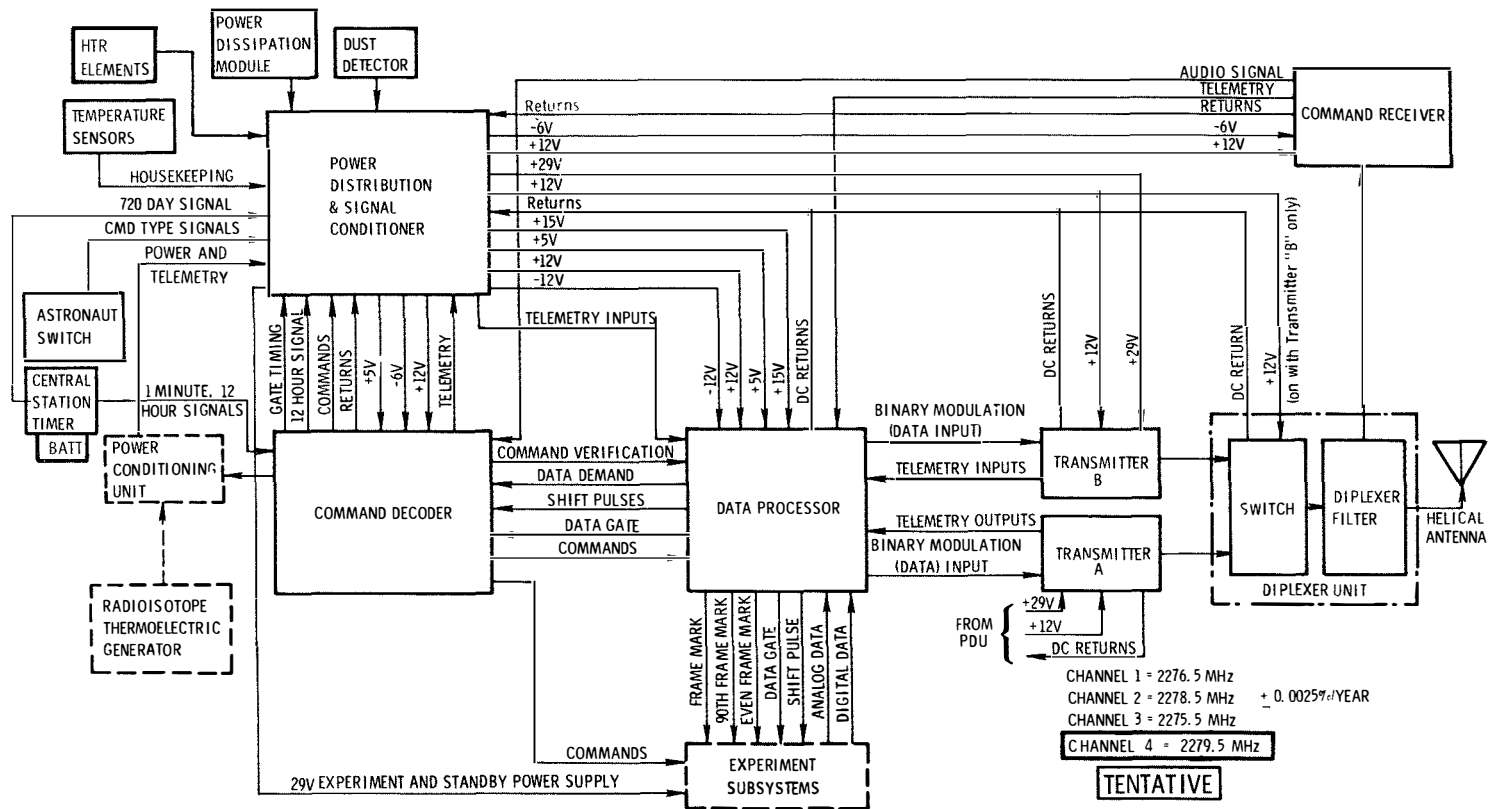

SEPT 68 5178.7.7

SUMMARY OF DATA S/S COMPONENTS

COMPONENT	VOLTAGE/POWER* REQUIREMENTS		TOTAL POWER	SIZE, IN.	WEIGHT LBS	RELIABILITY
POWER DISTRIBUTION UNIT	+29V	375 mw	1753 mw	2.8x4.0x7.25	2.29	0.94484
	+15V	75 mw				
	±12V	735 mw				
	± 5V	85 mw				
	- 6V	8 mw				
	-12V	475 mw				
COMMAND DECODER	+12V	325 mw	1330 mw	2.8x3.94x6.25	2.68	0.98304
	± 5V	775 mw				
	- 6V	230 mw				
DATA PROCESSOR	+12V	50 mw	500 mw	2.8x3.94x6.25	2.64	0.95863
	+ 5V	450 mw				
MULTIPLEXER	+15V	65 mw	1435 mw	2.62x4.23x5.92	1.89	
	±12V	150 mw				
	± 5V	1100 mw				
	-12V	120 mw				
TRANSMITTER (EACH)	+29V	8000 mw	8500 mw	1.5x2.0x7.5	1.17	0.9796
	+12V	500 mw				
RECEIVER	+12V	665 mw	695 mw	1.5x4.0x8.0	3.01	0.98888
	- 6V	30 mw				
DIPLEXER SWITCH	+12V	150 mw	150 mw	2.1x4.0x4.5	1.31	0.9997
DIPLEXER FILTER	-	-	-	2.5x2.5x7.0		0.9989
ANTENNA	-	-	-	1.5x23+ GND PL	1.05	-
AIM MECHANISM	-	-	-	11x4.25x5.75	2.06	-
CENT STA TIMER	BATTERY		-	1.32x1.32x2.63	.036	-
HARNES ASSY (INCLUDES PCB s CONNECTORS & SWITCHES)					2.92	-
TOTAL POWER AND WEIGHT			14.345 w		22.55	

* MEASURED POWER AT ROOM TEMPERATURE

** INCLUDES DIPLEXER FILTER

APR 69 5178.7.8

ALSEP COMMAND LINK

- * ANTENNA
- * DIPLEXER
- * COMMAND RECEIVER
- * COMMAND DECODER

NOV 67 5178.7.9

COMMAND LINK CHARACTERISTICS

FUNCTION/PARAMETER	ALSEP	MSFN
1. FREQUENCY	2119 ± 0.001 % MHz	2119 MHz
2. MODULATION	—	PM, ± 3 RADIANS
3. MODULATING SIGNAL	—	1 KHz SINE WAVE SYNC SIGNAL LINEARLY ADDED TO A 2 KHz SUBCARRIER
4. DATA RATE		1000 bps
5. IF BANDWIDTH (3 db)	275 ± 25 KHz	—
6. RECEIVER DYNAMIC RANGE	- 101 TO - 61 dbm	—
7. PERMISSIBLE Pe (PROBABILITY OF BIT ERROR)	10 ⁻⁹	
8. REQUIRED PREDETECTION S/N FOR 10 ⁻⁹ BER	+ 12 db	
9. S/N MARGIN FOR Pe of 10 ⁻⁹ (30' ANTENNA)	NOMINAL +32 db WORST CASE +28 db	

NOV 67 5178.7.10

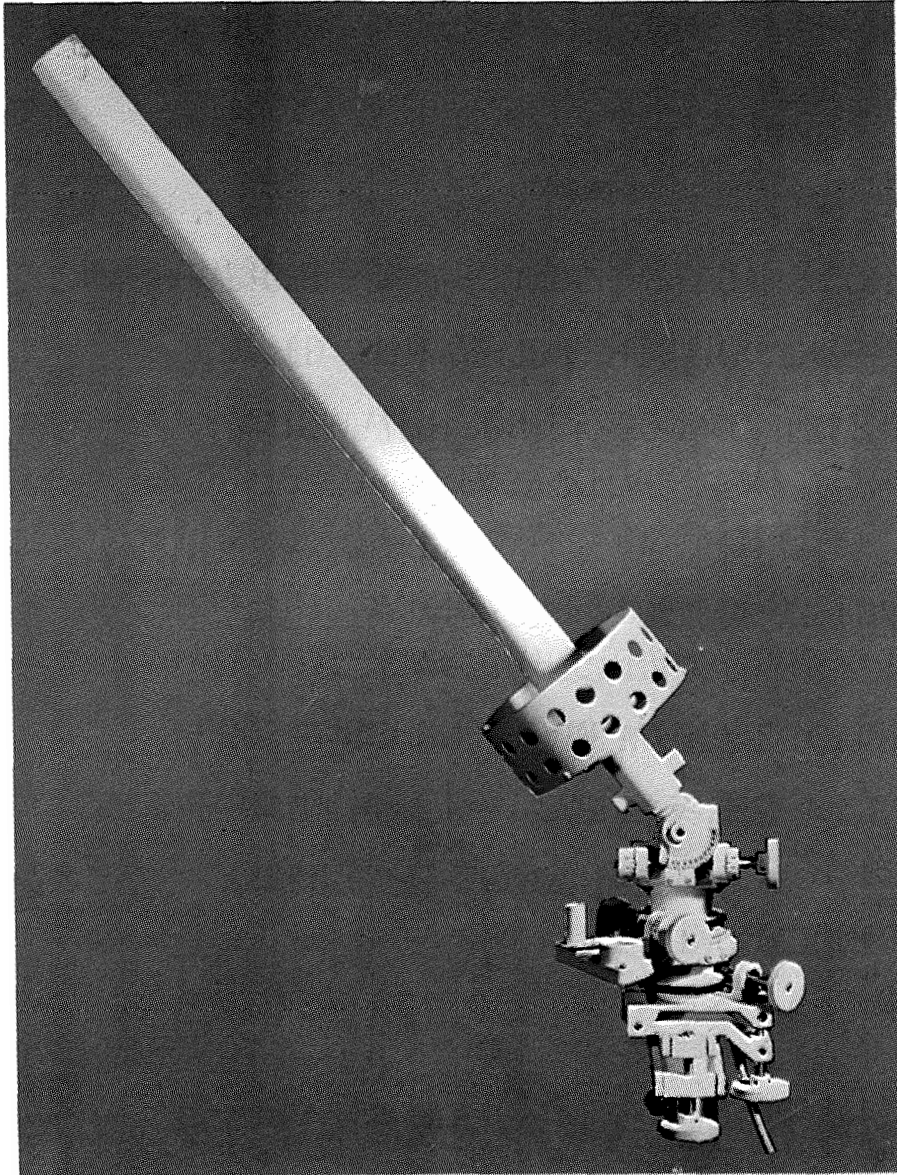

ANTENNA AND AIMING MECHANISM

JAN 68 5178.7.11

ANTENNA DESCRIPTION



- * FLAT "RIBBON-LIKE" COPPER CONDUCTOR WRAPPED AROUND FIBERGLASS-EPOXY TUBE
- * 1 1/2 INCHES IN DIAMETER AND 23 INCHES LONG
- * USES 5" GROUND PLANE WITH A 2" CYLINDRICAL SKIRT
- * IMPEDANCE MATCHING TRANSFORMER AT ANTENNA FEED POINT MATCHES THE ANTENNA IMPEDANCE TO A 50 OHM COAXIAL LINE
- * DESIGNED FOR EASY ATTACHMENT TO THE POINTING MECHANISM WITH "QUICK-CONNECT" SPRING LOADED DETENTS
- * COATED WITH WHITE REFLECTING THERMAL PAINT
- * WEIGHT - 1.28 POUNDS INCLUDING CONNECTOR AND CABLE

ANTENNA CHARACTERISTICS

	<u>TRANSMIT</u>		<u>RECEIVE</u>	
	SPEC	MEAS	SPEC	MEAS
GAIN				
ON BORESIGHT	15.2 db	16.0 db	14.7 db	15.2 db
BEAMWIDTH AT 11.0 db GAIN			27°	36°
BEAMWIDTH AT 11.5 db GAIN	27°	33°		
AXIAL RATIO	3 db	1.3 db	3 db	1.0 db
INPUT VSWR	1.25 : 1	1.20 : 1	1.5 : 1	1.20 : 1
SIDELobe LEVEL	-10 db	-11 db	-10 db	11.3 db
WEIGHT (ACTUAL)	1.28 LB s (including cable)			

SEPT 68 5178.7.13

ANTENNA TEST

1. ANTENNA PATTERN THRU ANT CENTERLINE AND FEED TERM (NOT SHOWN) 
2. ANTENNA PATTERN THRU ANT CENTERLINE AND 90° TO TERM (SHOWN BELOW) 

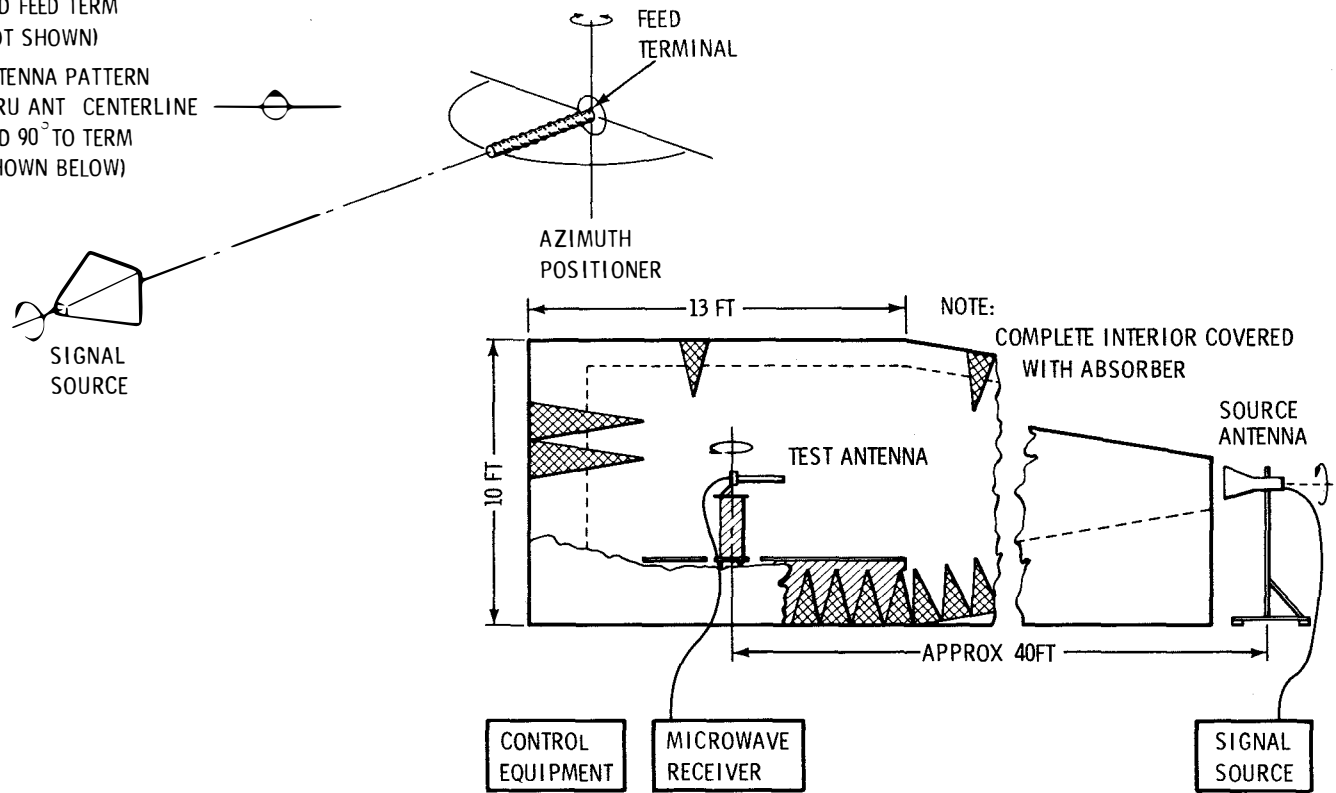

NOV 67 5178.7.14

ANTENNA PATTERN (DOWNLINK)

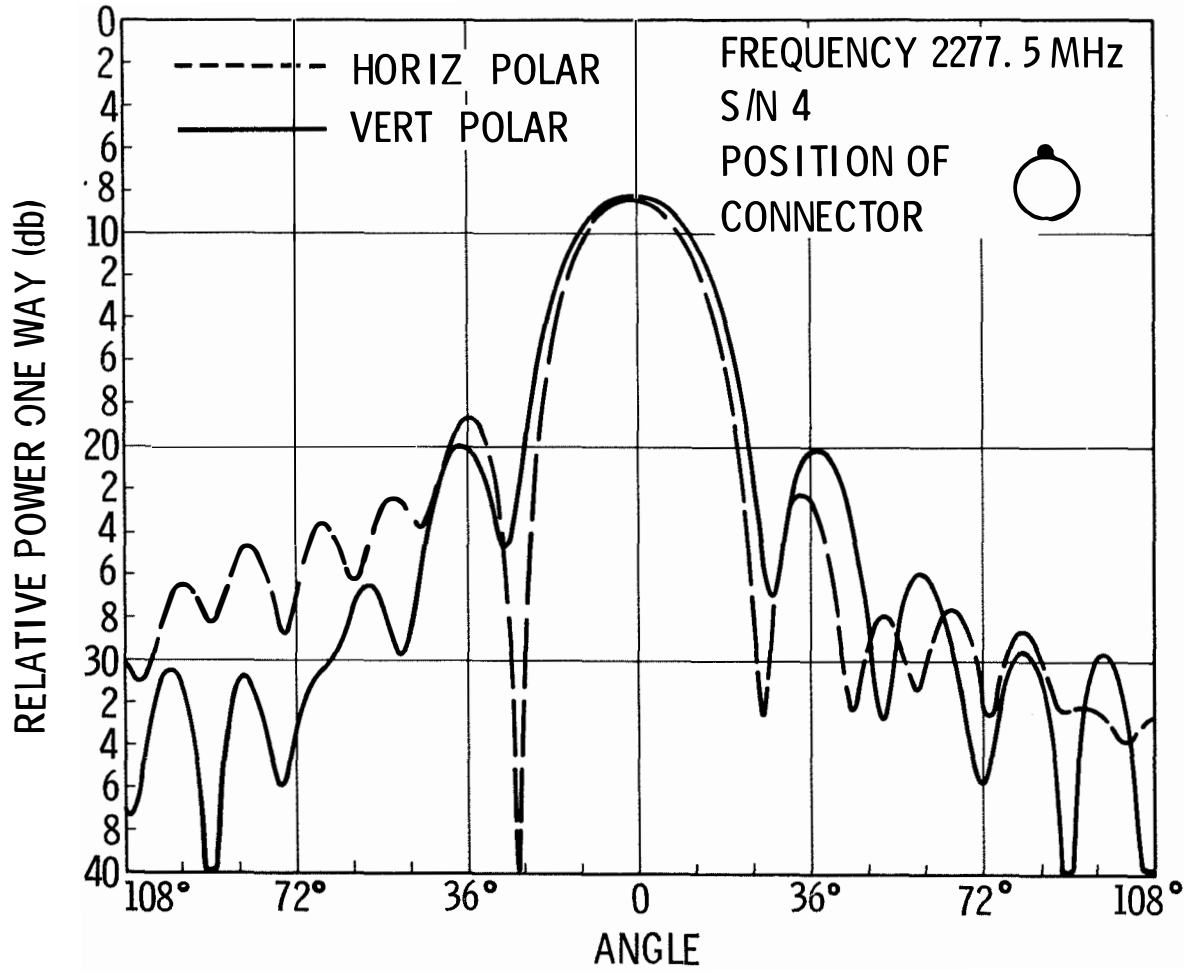

ANTENNA PATTERN (UPLINK)

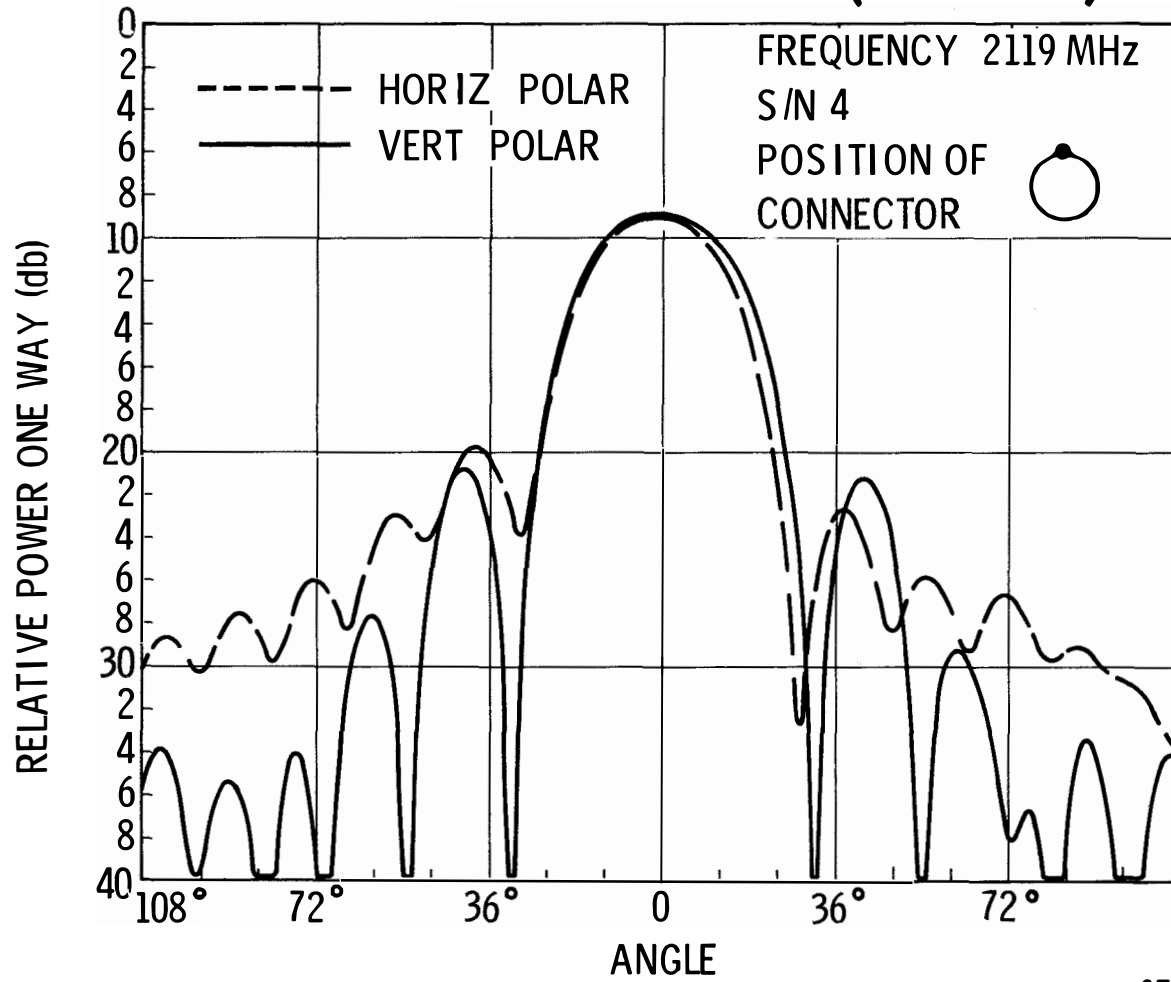

DIPLEXER FILTER

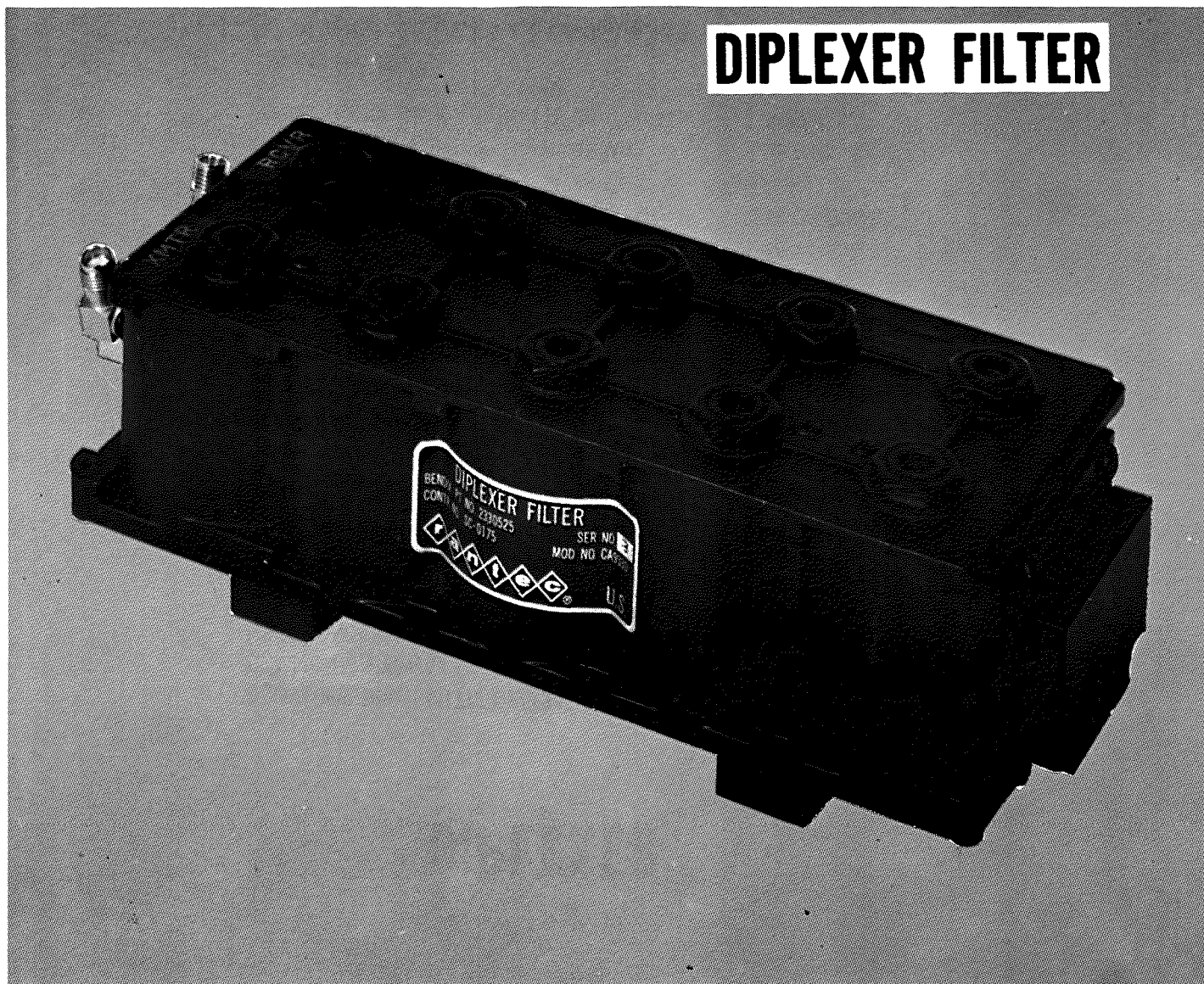

JAN 68 5178.7.17

DIPLEXER

- * PROVIDES TRANSMITTER/RECEIVER ISOLATION WITH A COMMON ANTENNA
- * USES TUNEABLE CAVITY BANDPASS FILTERS - 5 IN TRANSMIT AND 5 IN RECEIVE PATH
- * CHARACTERISTICS

<u>RECEIVER PATH</u>	<u>MEAS</u>	<u>SPEC</u>
INSERTION LOSS	1. 30 db	2. 5 db
VSWR	1. 10:1	1. 36:1
CENTER FREQUENCY:	2119	2118-2120 MHz
MAX 3 db BANDWIDTH	11. 0 MHz	24 MHz
MIN 3 db BANDWIDTH	11. 0 MHz	2. 18 MHz
<u>TRANSMITTER PATH</u>		
INSERTION LOSS:	0. 70 db	0. 8 db
VSWR	1. 10:1	1. 36:1
CENTER FREQUENCY	2275-2280 MHz	2275-2280 MHz
MAX 3 db BANDWIDTH	45 MHz	60 MHz
MIN 3 db BANDWIDTH	45 MHz	5. 35 MHz
POWER HANDLING CAPABILITY	20. 0 WATTS	1. 5 WATTS

- * MISCELLANEOUS
 - DIMENSIONS - 2. 5 x 2. 5 x 6. 88 INCHES
 - WEIGHT - 0. 9 POUNDS

NOV 67 5178.7.18

DIPLEXER FILTER

MINIMUM REJECTION REQUIREMENTS

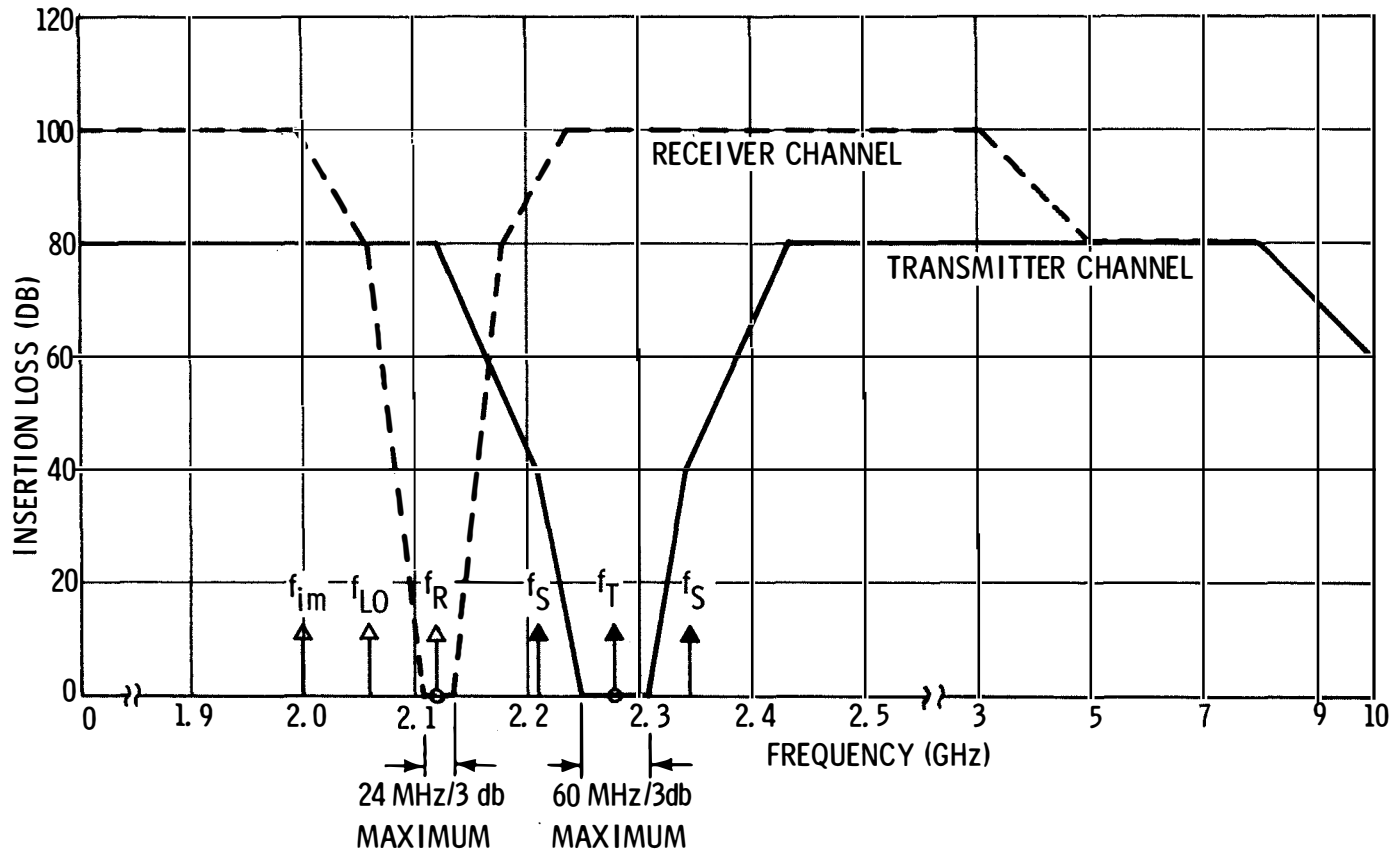

COMMAND RECEIVER

TOP VIEW

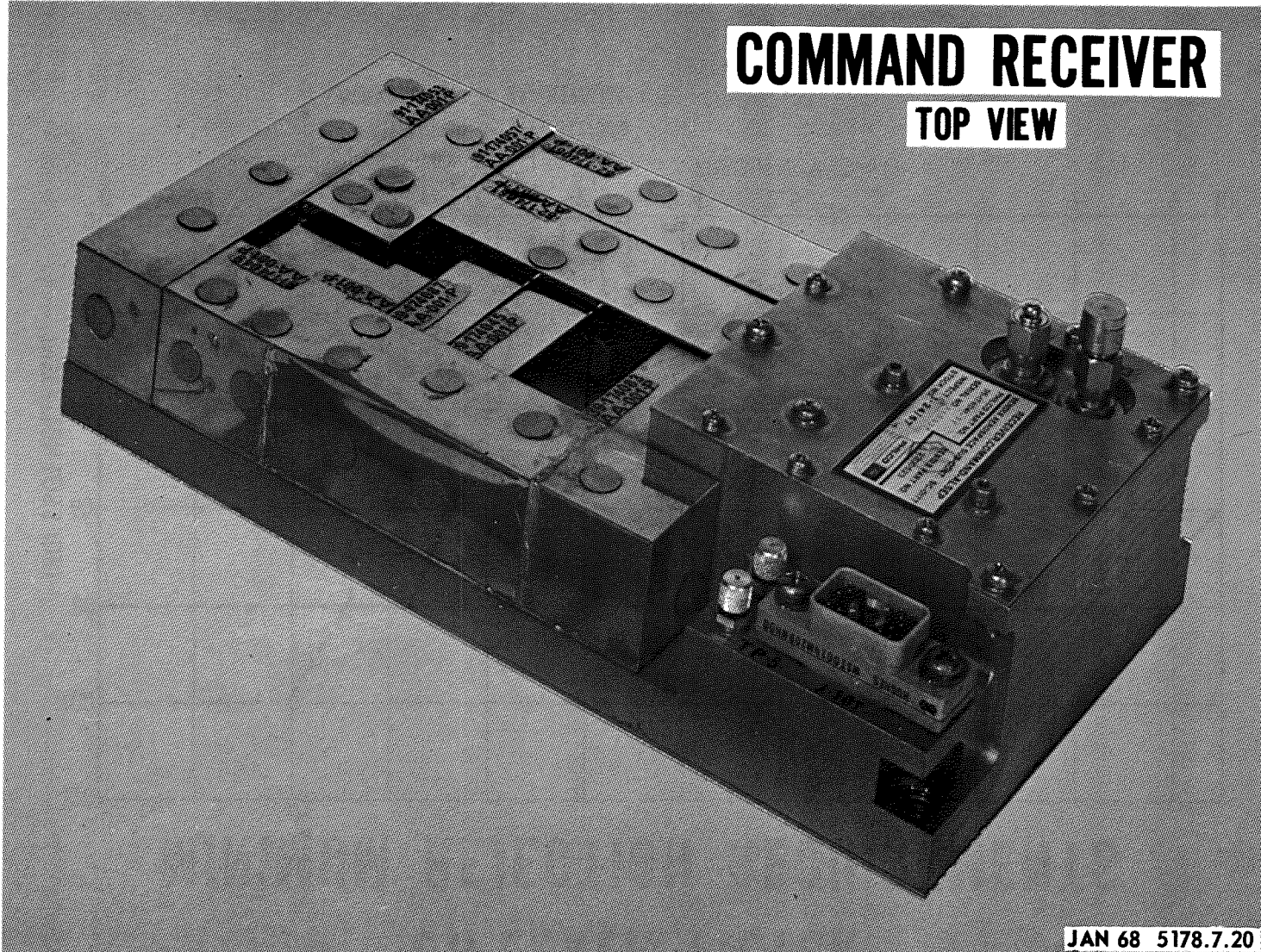

JAN 68 5178.7.20

COMMAND RECEIVER

BOTTOM VIEW

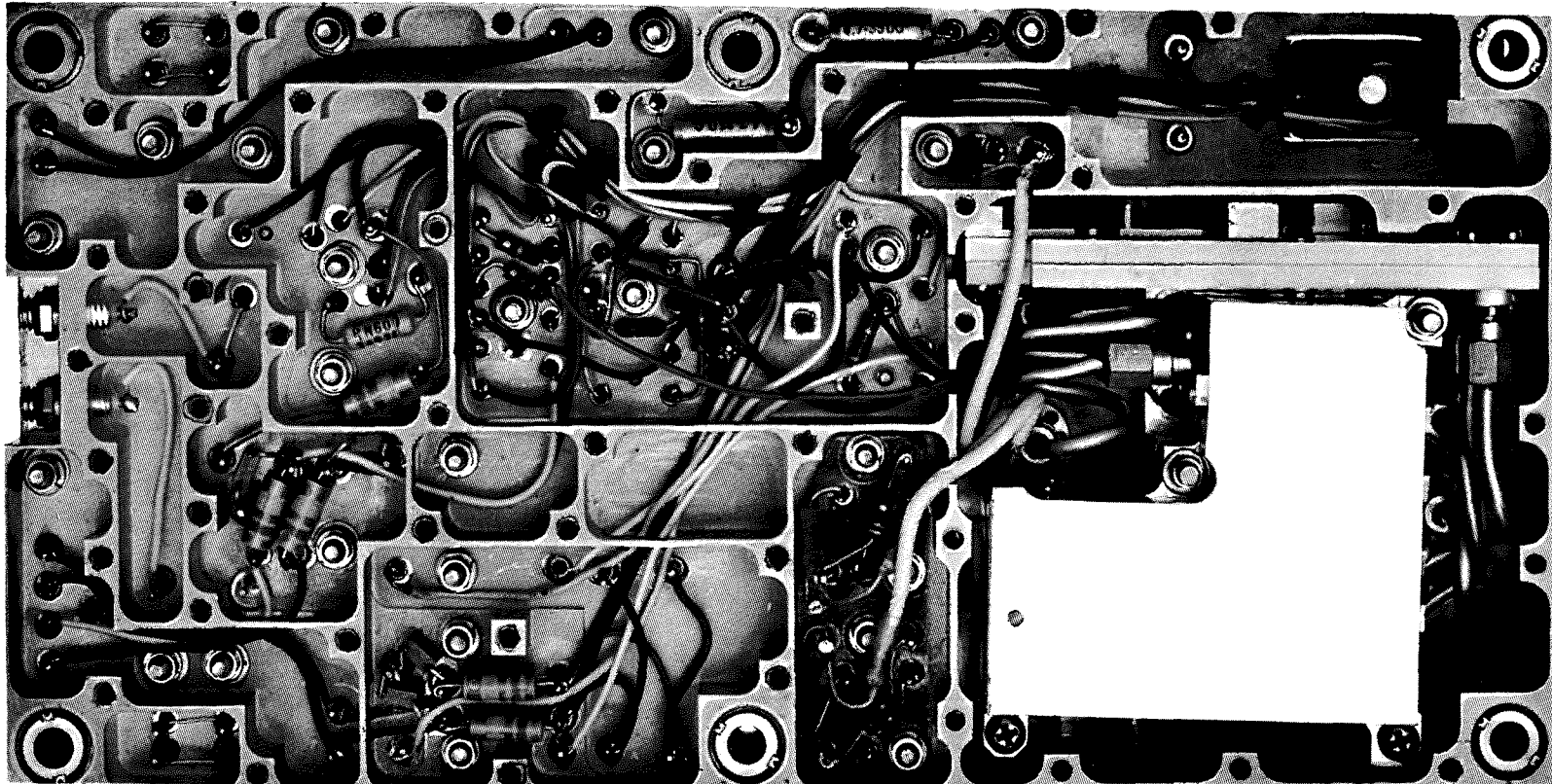

JAN 68 5178.7.21

COMMAND RECEIVER

- * RECEIVES SIGNALS FROM THE MSFN STATIONS ON A FREQUENCY OF 2119 MHz.
- * LOW SIDE LOCAL OSCILLATOR INJECTION PROVIDED BY STANDBY REDUNDANT LOCAL OSCILLATORS.
- * SYNCHRONOUS TUNED IF AMPLIFIERS PROVIDE AMPLIFICATION, FILTERING AND 40db LIMITING PRIOR TO SIGNAL DEMODULATION.
- * FM DISCRIMINATOR AND INTEGRATOR GIVES COMBINED 1 and 2 KHz OUTPUT.
- * OUTPUT LEVEL IS 0.8 VOLTS/RADIAN FOR AN INPUT DEVIATION OF 3.0 RADIANS.
- * EMPLOYS MODULAR CONSTRUCTION ON A "MILLED" MAGNESIUM BASE PLATE.
- * SIZE - 8 x 4 x 1.75 INCHES
WEIGHT - 1.84 POUNDS
- * POWER - 665 MILLIWATS (NOMINAL) AT + 12 vdc
30 MILLIWATTS (NOMINAL) AT - 6 vdc

APR 69 5178.7.22

COMMAND RECEIVER SIMPLIFIED BLOCK DIAGRAM

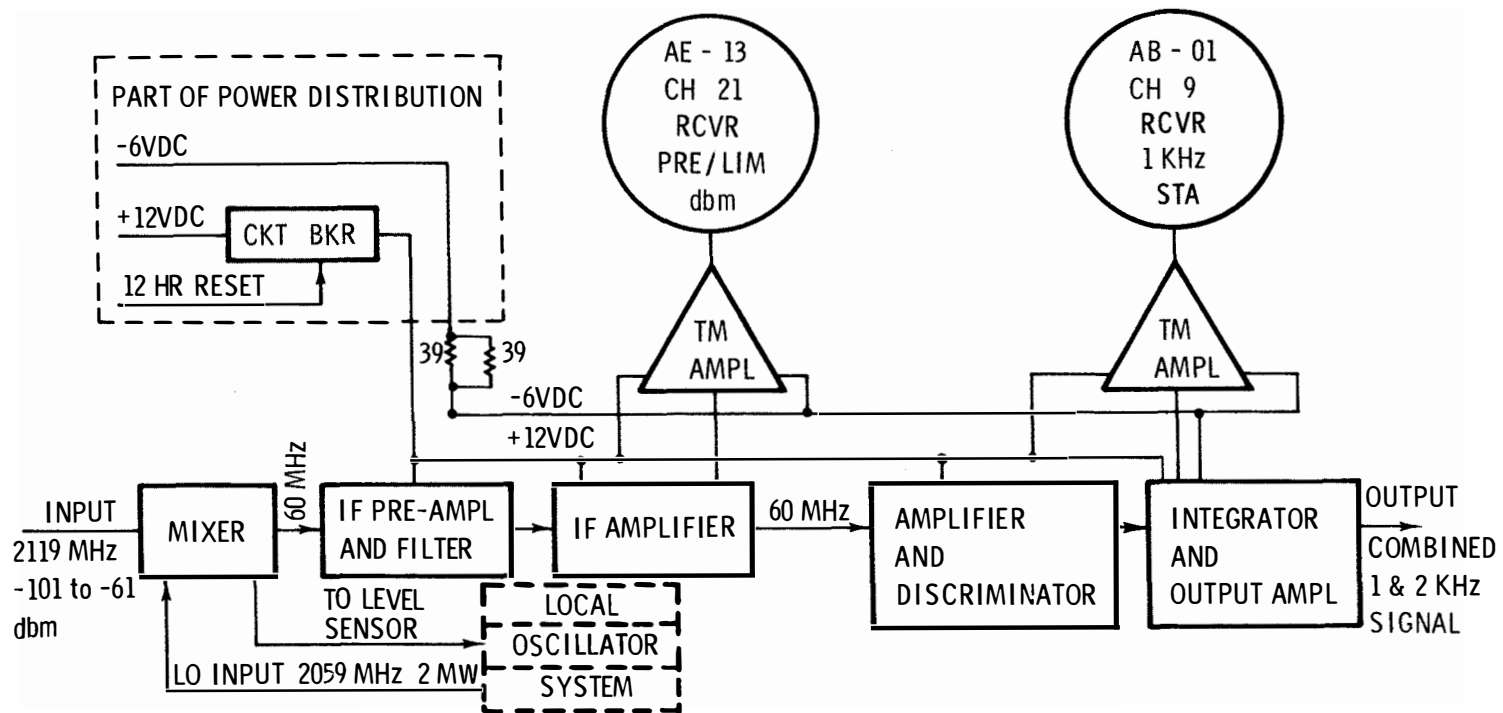

SEPT 68 5178.7.23

COMMAND RECEIVER

LOCAL OSCILLATOR BLOCK DIAGRAM

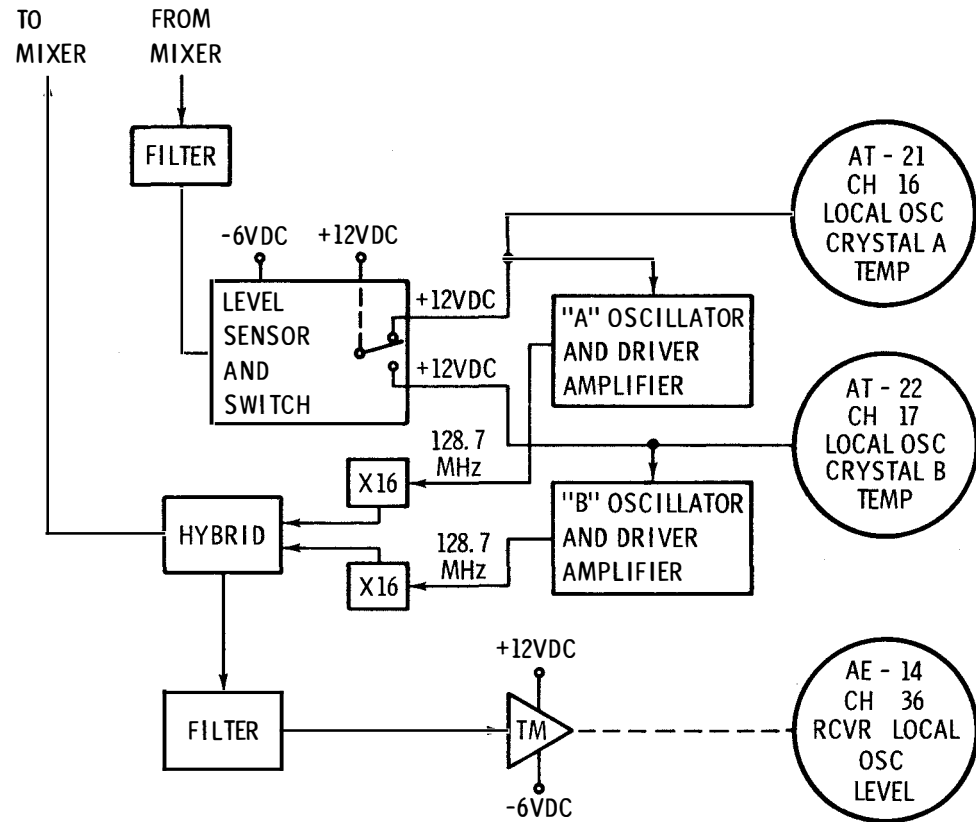

SEPT 68 5178.7.24

COMMAND RECEIVER TELEMETRY SUMMARY

CHANNEL 36	AE-14	RCVR LOCAL OSC LEVEL * DETECTOR CIRCUIT SAMPLES OSCILLATOR SIGNAL. DETECTED SIGNAL IS THEN AMPLIFIED TO PROPER TM LEVEL
CHANNEL 16	AT-21	LOCAL OSC CRYSTAL A TEMP * USES THERMISTOR/RESISTOR NETWORK POWERED BY 12 VDC. * THERMISTOR IS CEMENTED (EPOXY) TO CRYSTAL CAN.
CHANNEL 17	AT-22	LOCAL OSC CRYSTAL B TEMP * USES THERMISTOR/RESISTOR NETWORK POWERED BY 12 VDC. * THERMISTOR IS CEMENTED (EPOXY) TO CRYSTAL CAN.
CHANNEL 9	AB-01	CMD DEMOD 1KHz PRESENT * SIGNAL IS OBTAINED FROM RECEIVER'S AUDIO OUTPUT. * USES 1KHz BANDPASS AMPLIFIER AND DIODE DETECTOR.
CHANNEL 21	AE - 13	RCVR PRE-LIMITING LEVEL * DIODES IN FINAL STAGE OF IF PROVIDE HARD LIMITING. * TM SIGNAL PROVIDED BY THE LIMITING DIODE CURRENT.

SEPT 68 5178.7.25

COMMAND RECEIVER SPECIFICATIONS

- * INPUT FREQUENCY 2119 MHz \pm 0.001 %
- * INPUT SIGNAL LEVEL -101dbm to -61dbm
- * NOISE FIGURE 10db MAXIMUM
- * LOCAL OSC FREQUENCY 2059 MHz \pm 0.0025%/YR
- * INTERMEDIATE FREQUENCY 60 MHz
- * IF 3db BANDWIDTH 250 to 350 KHz WITH AN
INPUT SIGNAL LEVEL OF -100dbm
- * IF REJECTION 60db MINIMUM AT 3.4 MHz
- * AUDIO OUTPUT SIGNAL
 - (a) LEVEL - 0.8 VOLT/RADIAN (UP TO \pm 3.0 RADIANS)
 - (b) FREQ - 100 Hz TO 5 KHz
- * POWER
 - + 12 VDC AT 55 MILLIAMPERES (NOMINAL) - SUPPLIED THROUGH
A CIRCUIT BREAKER RATED AT 150 MILLIAMPERES (NOMINAL).
CIRCUIT IS AUTOMATICALLY GIVEN A RESET COMMAND EVERY
12 HOURS.
 - 6VDC AT 55 MILLIAMPERES (NOMINAL) - SYSTEM PROTECTION
PROVIDED BY SERIES RESISTOR.
- * CONNECTORS - RF - COAXIAL OSM 210-2
 - OTHER - HUGHES WST0014M20BNH00

SEPT 68 5178.7.26

COMMAND DECODER

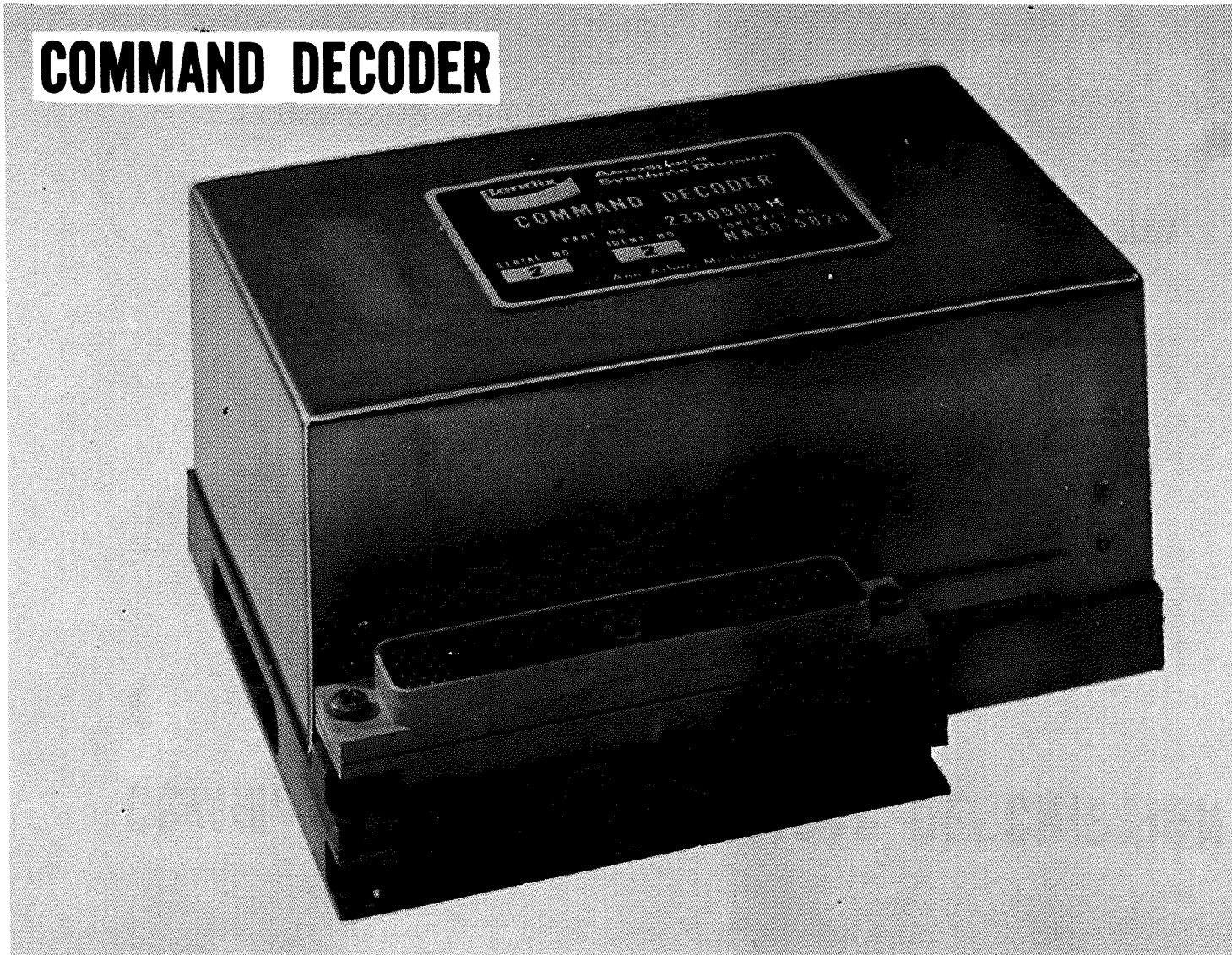

JAN 68 5178.7.27

COMMAND DECODER PHYSICAL DESCRIPTION

- * SIZE - 2.8 x 3.94 x 6.25 INCHES
- * POWER - 1330 MILLIWATTS (NOMINAL AT ROOM AMBIENT)
- * WEIGHT - 2.70 POUNDS
- * PARTS COUNT - 352 FLATPACKS
 - 26 TRANSISTORS
 - 83 RESISTORS
 - 28 CAPACITORS
 - 13 DIODES
- * PARTS MOUNTED ON 10 PRINTED CIRCUIT BOARDS WITH FROM
2 to 12 LAYERS
- * CONNECTOR - HUGHES - 244 PIN

COMMAND DECODER SIMPLIFIED BLOCK DIAGRAM

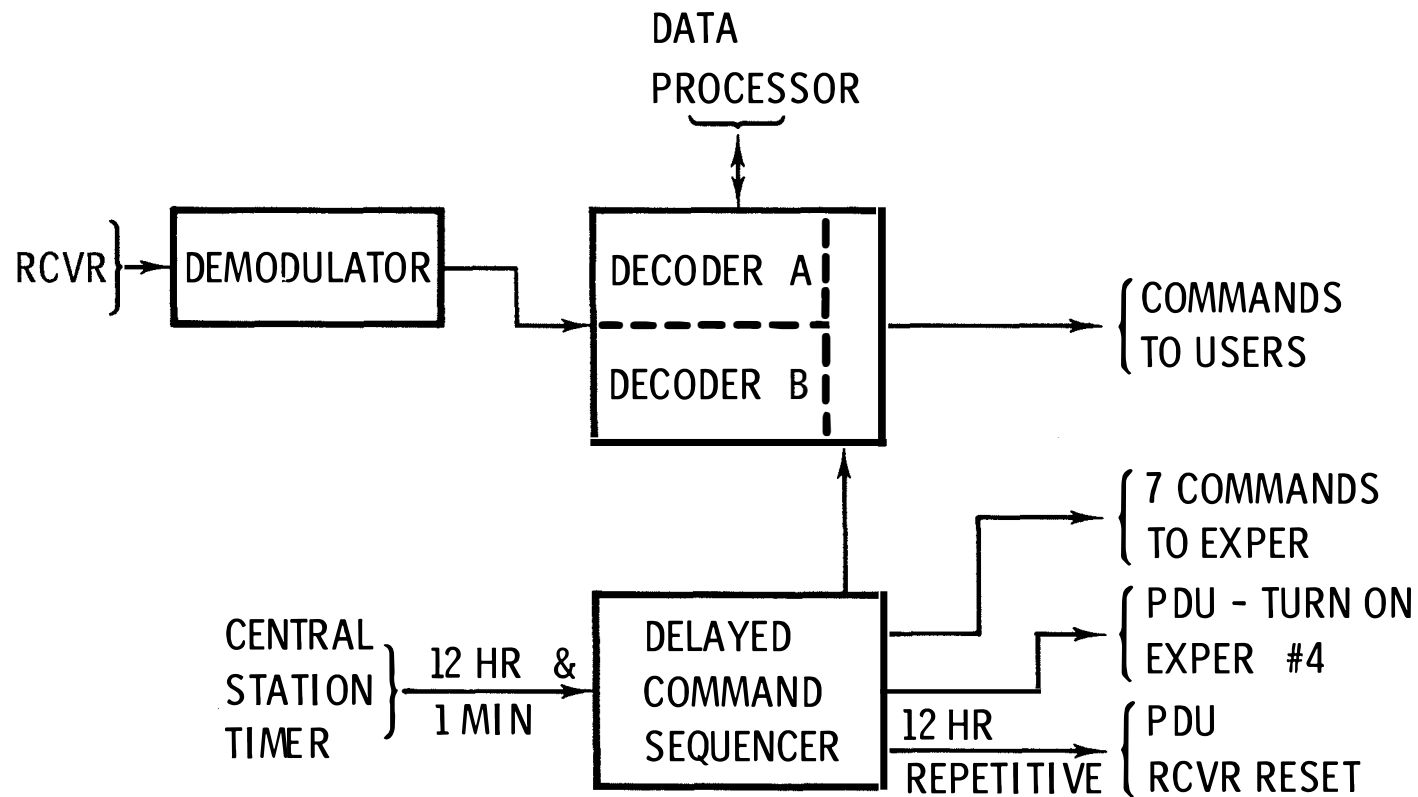

SEPT 68 5178.7.29

COMMAND DECODER

* CONTAINS A DEMODULATOR

- TO GENERATE AN NRZ-C BIT STREAM FROM THE PHASE MODULATED COMPOSITE 1 & 2 KHz AUDIO INPUT
- WHICH DETECTS " THRESHOLD" TO START DECODER "SEARCH MODE".
- TO GENERATE 1,2 AND 4 KHz TIMING CLOCKS WHICH ARE SYNCHRONIZED WITH THE 1KHz SYNC SUBCARRIER RECEIVED FROM THE MSFN.

* ACCEPTS COMMAND SIGNALS FROM THE MSFN NETWORK AND PROVIDES UP TO 100 UNIQUE COMMANDS TO USERS.

* A COMMAND FROM THE MSFN CONSISTS OF A 2KHz SUBCARRIER PHASE MODULATED WITH A 1KHz SUBCARRIER TO PRODUCE 61 SERIAL BITS WITH THE FOLLOWING FORMAT.

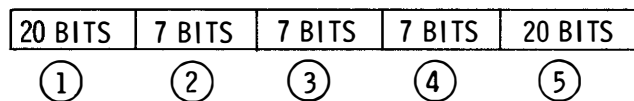

1. - PREAMBLE - ALL ONES OR ALL ZEROS
2. - ADDRESS INDIVIDUAL ALSEP (A or B DECODER)
3. - COMMAND COMPLEMENT
4. - COMMAND
5. - TIMING (EXECUTION) - ALL ONES OR ALL ZEROS

SEPT 68 5178.7.30

COMMAND DECODER ADDRESSING

- * THE SEVEN ADDRESS BITS ARE USED TO UNIQUELY COMMAND FOUR SEPARATE ALSEPs DEPLOYED ON THE LUNAR SURFACE.
- * EACH COMMAND DECODER HAS AN "A" SECTION AND A REDUNDANT "B" SECTION. EITHER MAY BE SELECTED TO PROCESS A COMMAND BY TRANSMITTING THE PROPER ADDRESS CODE.
- * CODES

ALSEP	ADDRESS NO. (OCTAL)	CODE PATTERN	COMMAND DECODER NUMBER
1	130	1011000	1A
	30	0011000	1B
2	116	1001110	2A
	16	0001110	2B
3	151	1101001	3A
	51	0101001	3B
4	25	0010101	4A
	65	0110101	4B

COMMAND DEMODULATOR

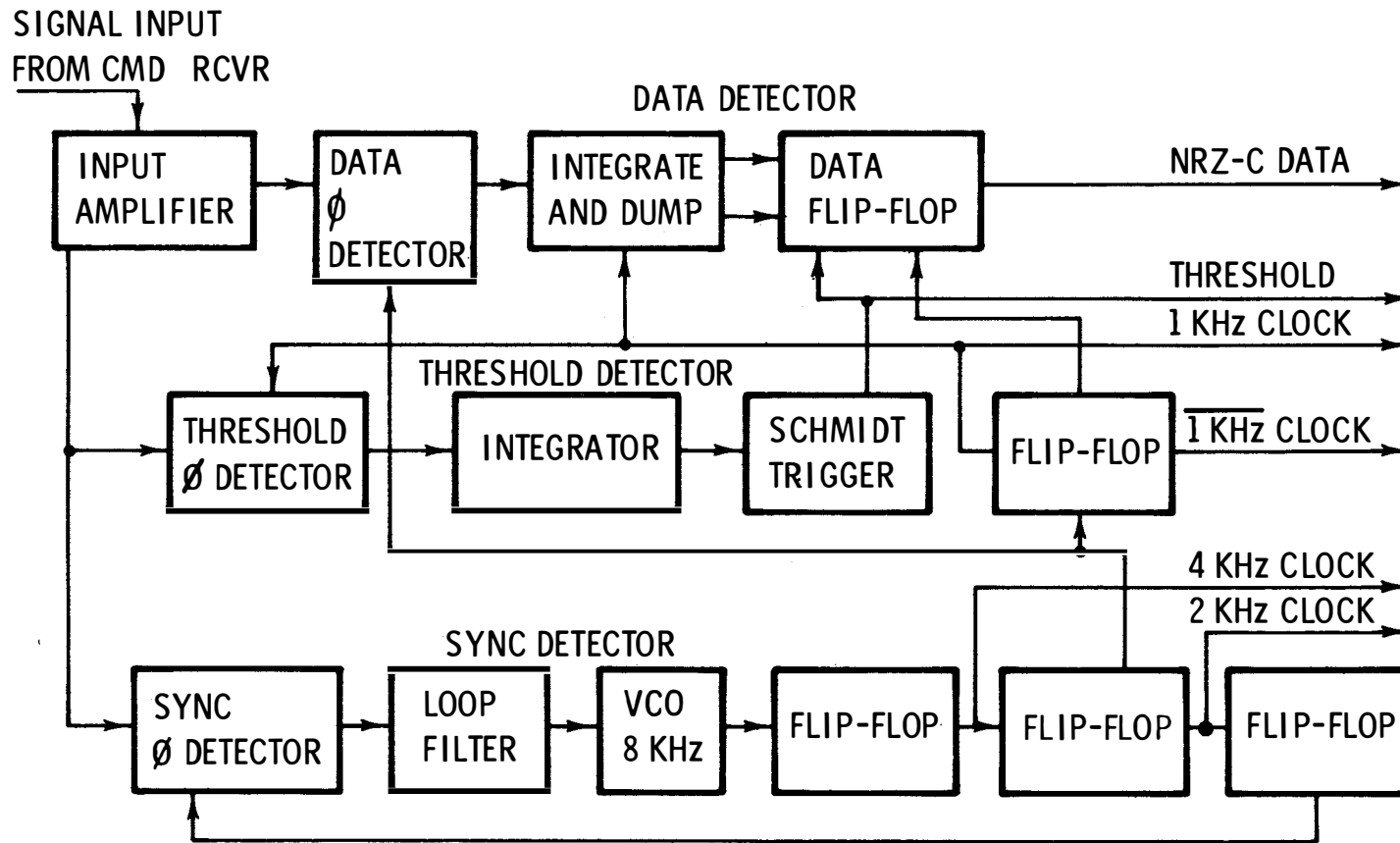

COMMAND DECODER SECTION BLOCK DIAGRAM-DIGITAL

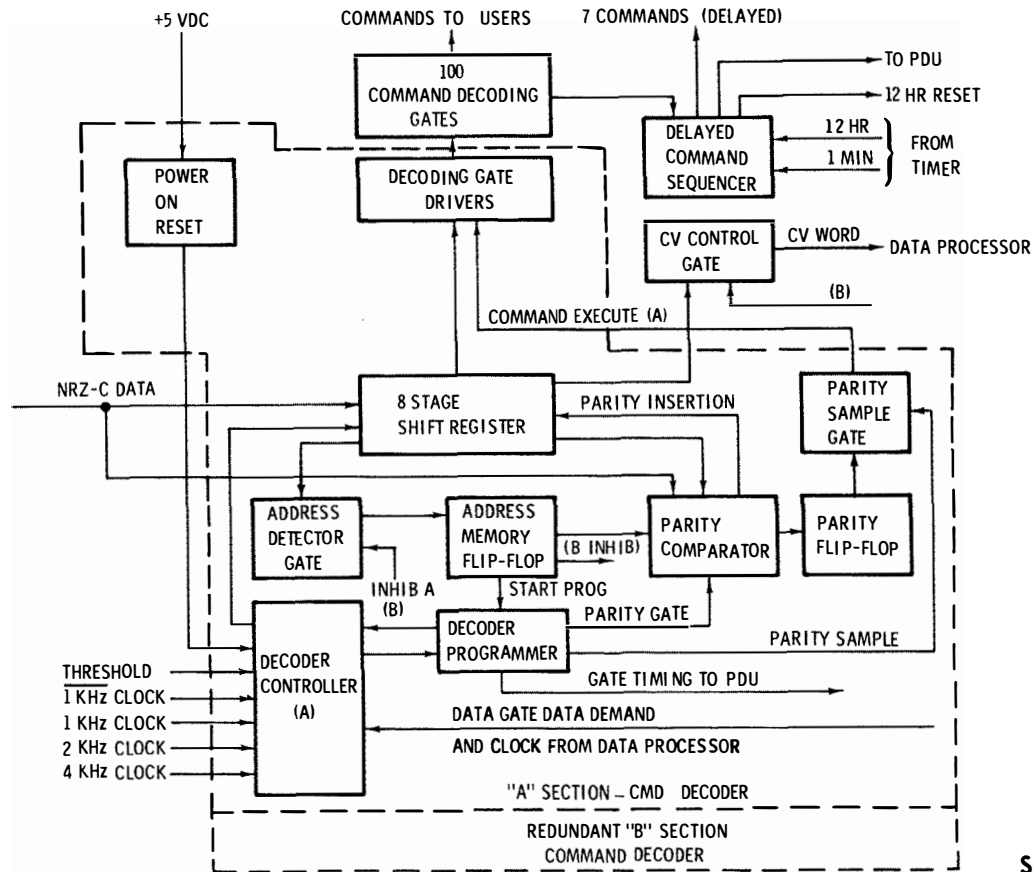

SEPT 68 5178.7.33

FUNCTIONAL FLOW CHART COMMAND DECODER

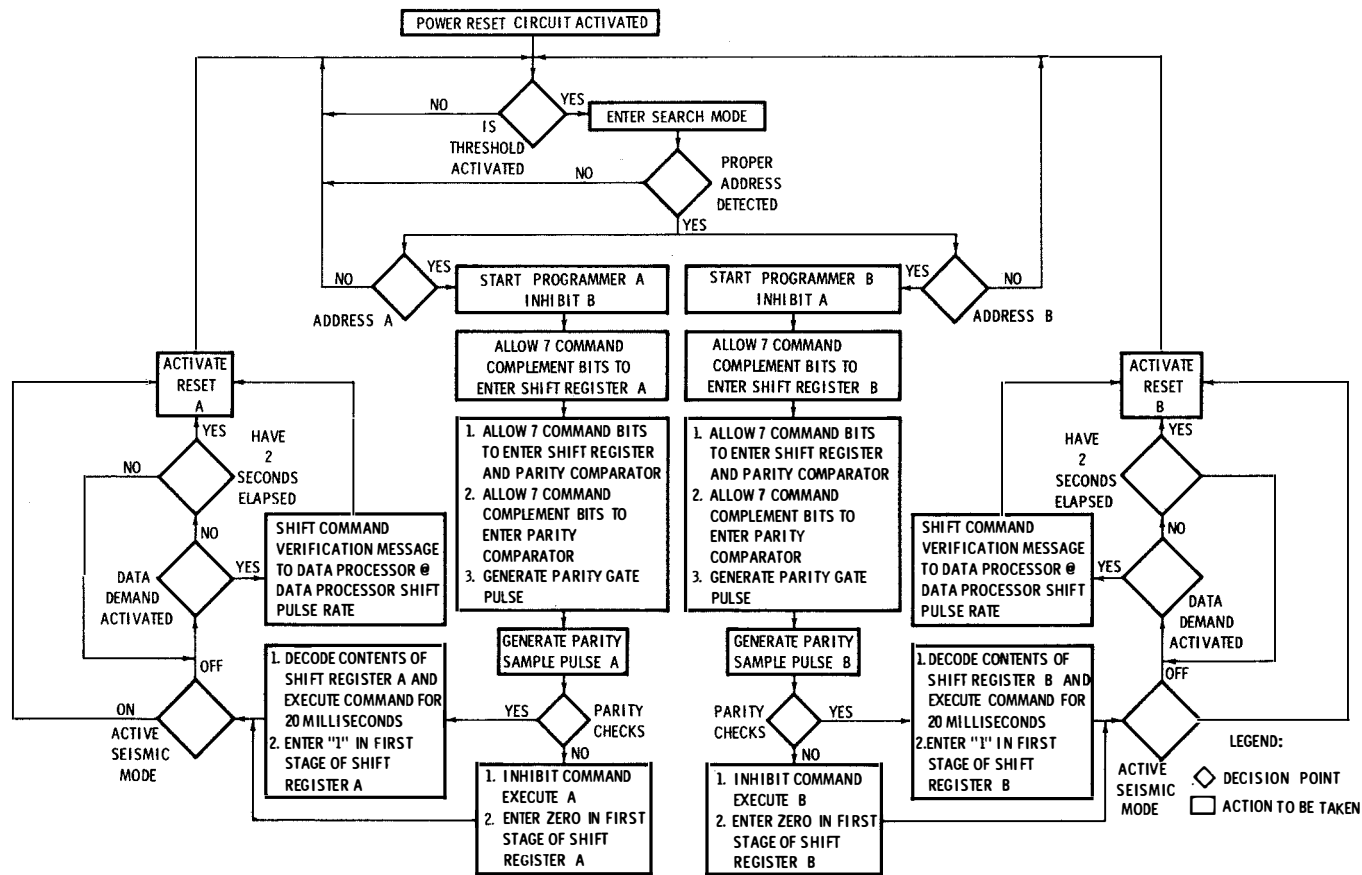

DEC 67 5178.7.34

COMMAND DECODER DELAYED COMMAND SEQUENCER

- * PROVIDES A BACKUP FEATURE FOR LOCAL GENERATION OF COMMANDS IN CASE THE COMMAND LINK CANNOT BE ESTABLISHED
- * GENERATES 7 ONE-TIME COMMANDS AFTER A DELAY OF 96 (PLUS) HOURS FROM START OF "PET" (WHERE "PET" STARTS AT THE TIME THE ASTRONAUT MATES THE RTG WITH THE CENTRAL STATION BY INSERTING P22 INTO J22)
- * COMMANDS ARE IDENTICAL TO THOSE GENERATED IN RESPONSE TO SIGNALS FROM THE MSFN AND ARE OR'ED IN THE COMMAND LINE DRIVER.
- * DELAYED (ONE-TIME) COMMANDS ARE IDENTIFIED AS FOLLOWS:

FUNCTION	TIME OF EXECUTION	COMMAND NUMBER (OCTAL)
REMOVE CPLEE DUST COVER	96 HRS & 2 MIN	113
SET CCIG SEAL BREAK	96 HRS & 2 MIN	105
UNCAGE PSE	96 HRS & 2 MIN	073
EXECUTE CCIG SEAL BREAK	96 HRS & 3 MIN	110
SWS DUST COVER REMOVAL	96 HRS & 4 MIN	122
SET SIDE DUST COVER	96 HRS & 4 MIN	107
EXECUTE SI DE DUST COVER REMOVAL	96 HRS & 5 MIN	110

SEPT 68 5178.7.35

DELAYED COMMAND SEQUENCER FUNCTIONAL FLOW CHART

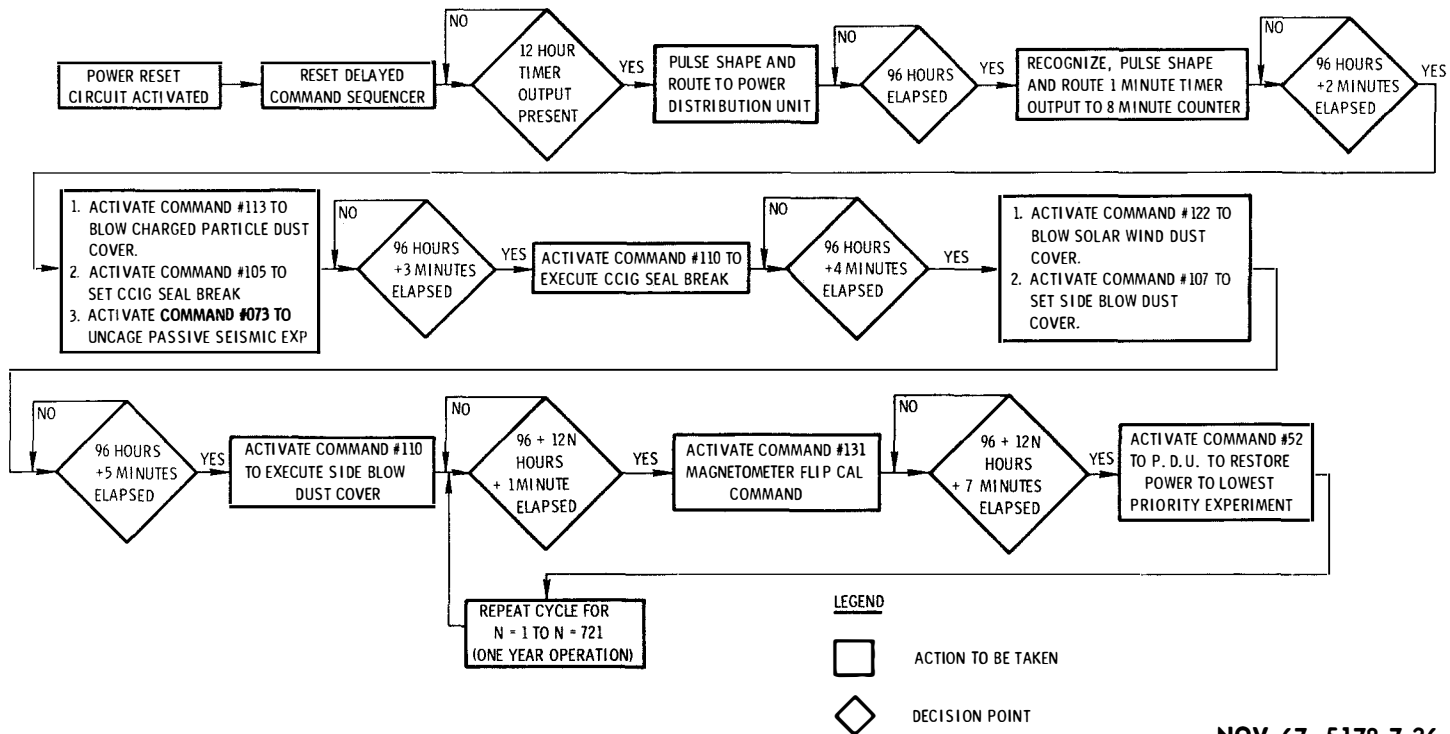

NOV 67 5178.7.36

COMMAND DECODER POWER RESET

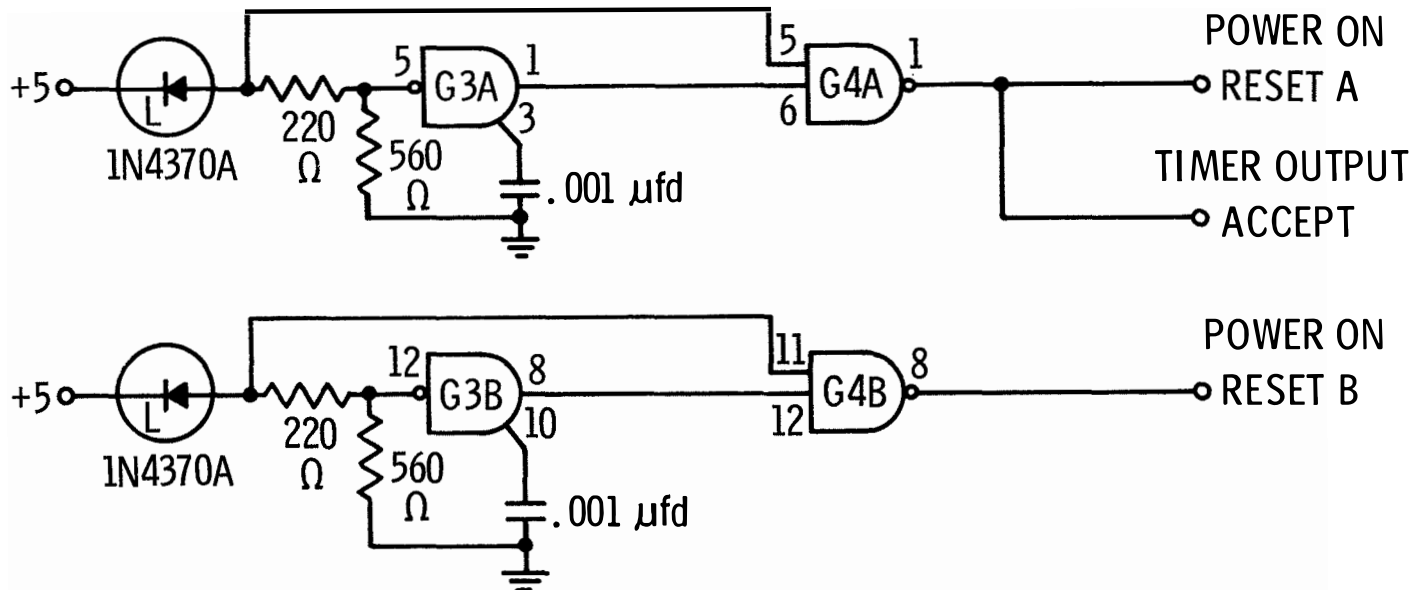

FEATURES

DETECTS INITIAL POWER TURN-ON OR
MOMENTARY POWER INTERRUPTION TO -

1. SET COMMAND DECODER IN SEARCH MODE
2. SET COMMAND DECODER IN "TIMER ACCEPT" MODE
3. START DELAYED COMMAND SEQUENCER

NOV 67 5178.7.37

COMMAND DECODER-OTHER LOCAL COMMANDS

THE FOLLOWING REPETITIVE COMMANDS ARE GENERATED WITHIN THE
COMMAND DECODER:

- 1 - PSE CALIBRATE - COMMAND #065
* OCCURS 12 HOURS AFTER T_0 AND EVERY 12 HOURS THEREAFTER
 - 2 - RECEIVER CIRCUIT BREAKER RESET
* OCCURS 12 HOURS AFTER T_0 AND EVERY 12 HOURS THEREAFTER
 - 3 - MAGNETOMETER FLIP-CALIBRATE - COMMAND #131
* FIRST OCCURRENCE IS 108 HOURS PLUS 1 MIN
AFTER T_0 - REPEATS EVERY 12 HOURS THEREAFTER
 - 4 - RESTORE POWER TO LOW PRIORITY EXPERIMENT - CMD #052
* FIRST OCCURRENCE IS 108 HOURS AND 7 MINUTES AFTER T_0
AND EVERY 12 HOURS THEREAFTER
- * ALL ABOVE COMMANDS MAY BE INHIBITED BY TRANSMITTING COMMAND #033
- COMMAND #033 IS CONSIDERED CRITICAL! SHOULD THE COMMAND
LINK BE LOST FOLLOWING TRANSMISSION OF CMD #033, THEN ALL
LOCALLY GENERATED COMMANDS WOULD BE LOST

TIMER/COMMAND DECODER INTERFACE

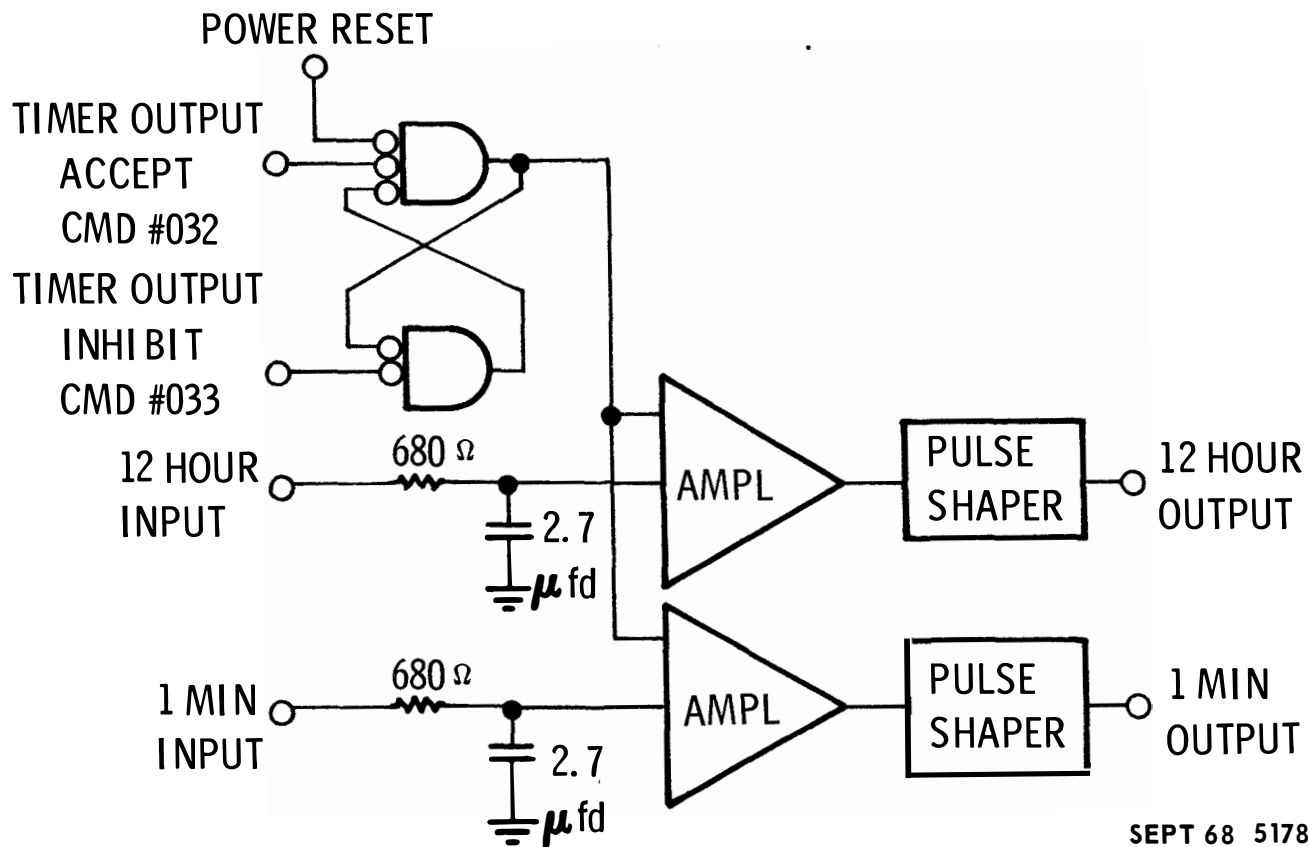

SEPT 68 5178.7.39

COMMAND DECODER INTERFACE

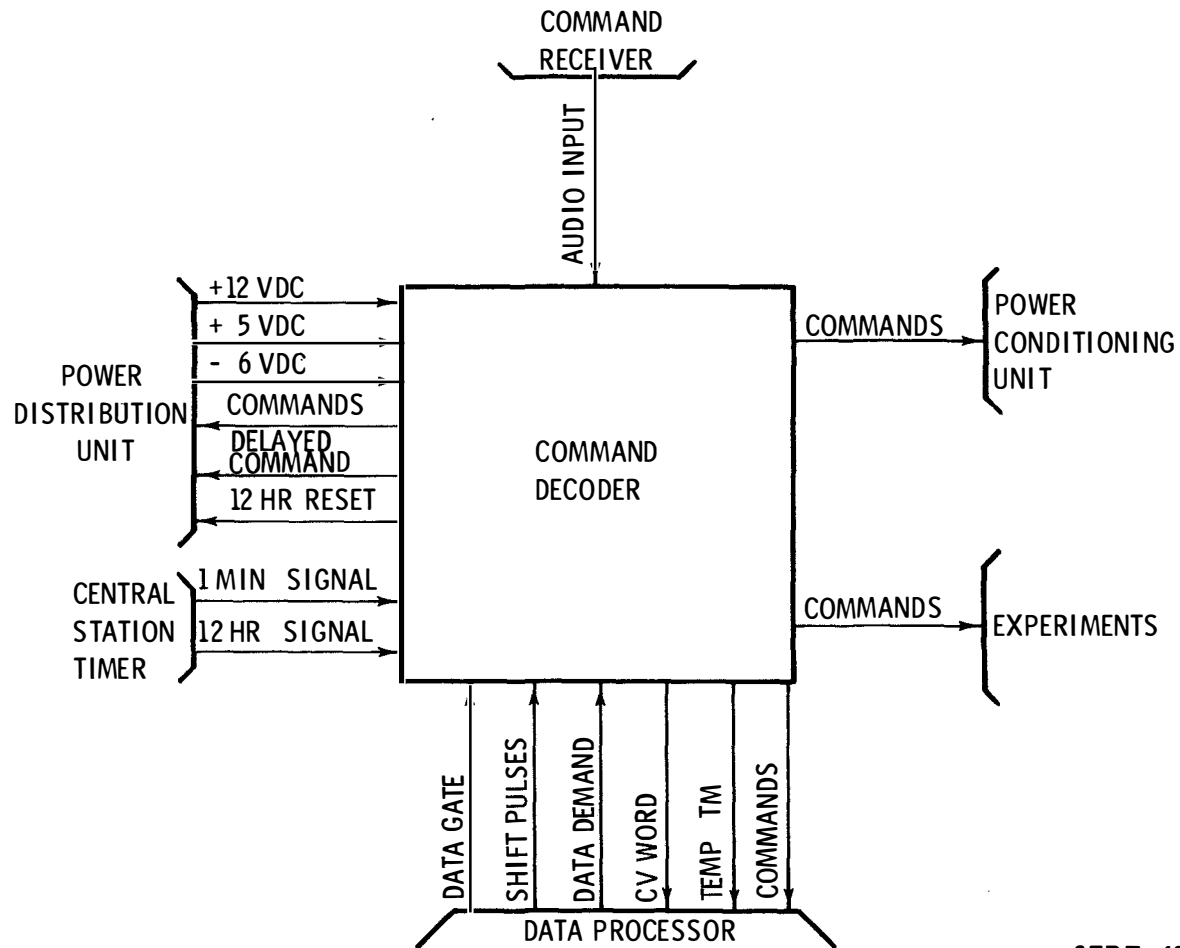

SEPT 68 5178.7.40

COMMAND DECODER INTERFACE CIRCUIT

(ONE EACH FOR 100 COMMANDS)

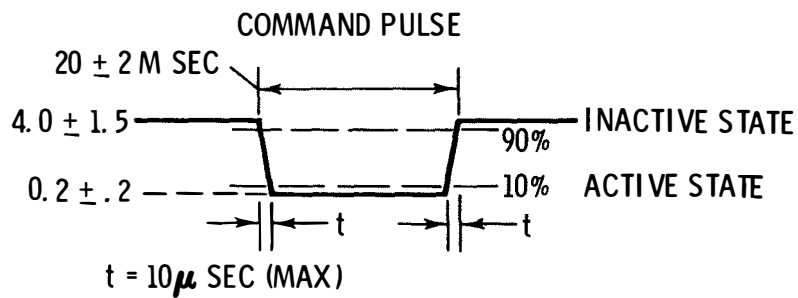
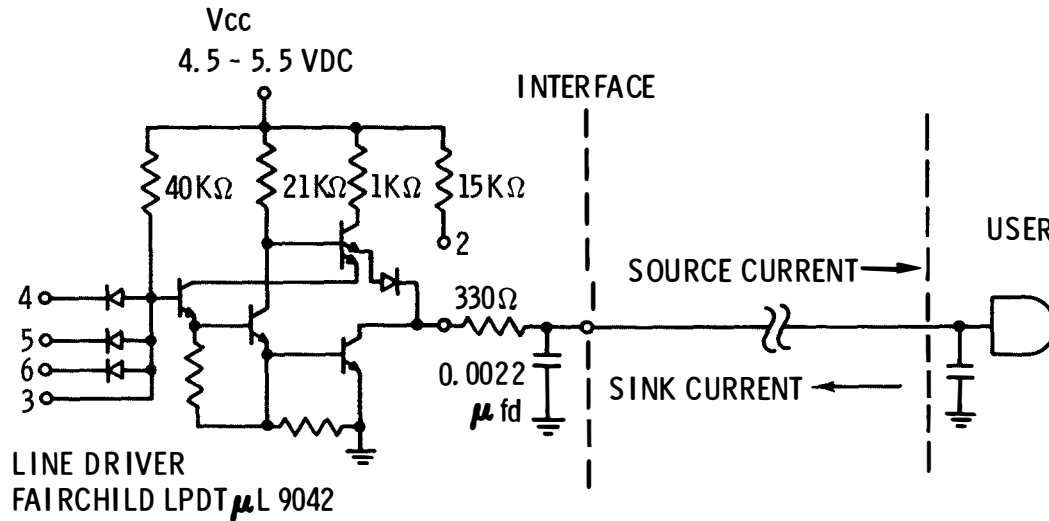

DRIVER SPECIFICATION

SOURCE I \leq 45 μ AMP
(INACTIVE STATE)

SINK I \leq 750 μ AMP
(ACTIVE STATE)

COMMAND DECODER TELEMETRY SUMMARY

* COMMAND VERIFICATION (CV) WORD

- LOCATED IN WORD 46 OF TELEMETRY FORMAT FOR FLIGHT SYSTEMS 1 & 2 AND IN WORD 5 FOR FLIGHT SYSTEMS 3 & 4
- CONSISTS OF 2 ZEROS, THE RECEIVED COMMAND AND A PARITY BIT
- EXAMPLE OF CV WORD RECEIVED AT THE MSFN

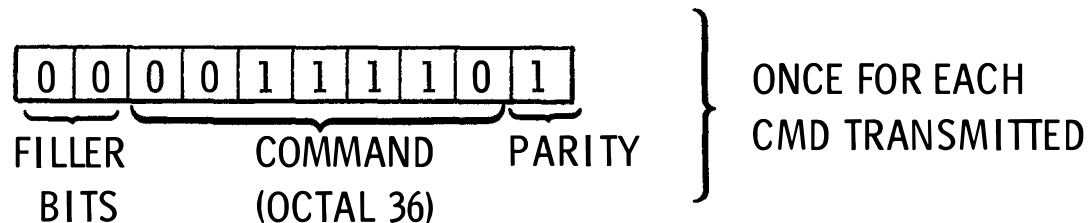

- PARITY " ONE" VERIFIES BIT BY BIT CHECK OF COMMAND WITH COMPLEMENT.
- THE SEVEN COMMAND BITS IDENTIFY THE BINARY CODE DETECTED BY THE COMMAND DECODER.

COMMAND DECODER TELEMETRY SUMMARY

CHANNEL 48	AT-31	<u>COMMAND DECODER BASE TEMP</u> *SIGNAL OBTAINED FROM THERMISTOR LOCATED NEAR CENTER OF BASE PLATE
CHANNEL 49	AT-32	<u>COMMAND DECODER INTERNAL TEMP</u> *THERMISTOR LOCATED ON "PULSE SHAPER" PRINTED CIRCUIT BOARD
CHANNEL 61	AT-33	<u>COMMAND DEMODULATOR, VCO TEMP</u> *THERMISTOR LOCATED ON DEMODULATOR PRINTED CIRCUIT BOARD

CIRCUITS - TEMPERATURE SENSING CIRCUITS ARE ARRANGED
AS FOLLOWS:

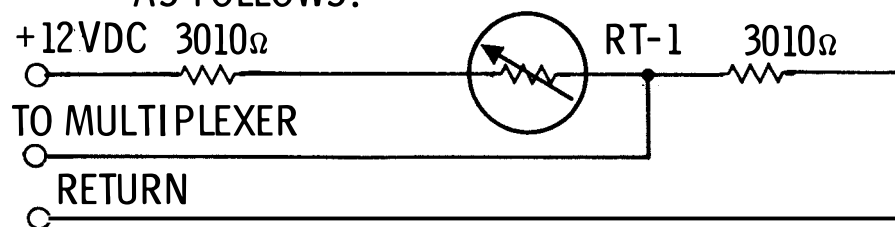

RT-1 "FENWAL" ISO-CURVE 15K ohm THERMISTOR.

SEPT 68 5178.7.43

TELEMETRY READOUT VS. TEMPERATURE

USED IN THE FOLLOWING
MEASUREMENTS:

AT-27	AT-05
AT-28	AT-06
AT-29	AT-07
AT-30	AT-34
AT-31	AT-35
AT-32	AT-36
AT-33	AT-37
AT-03	AT-38
AT-04	AT-39

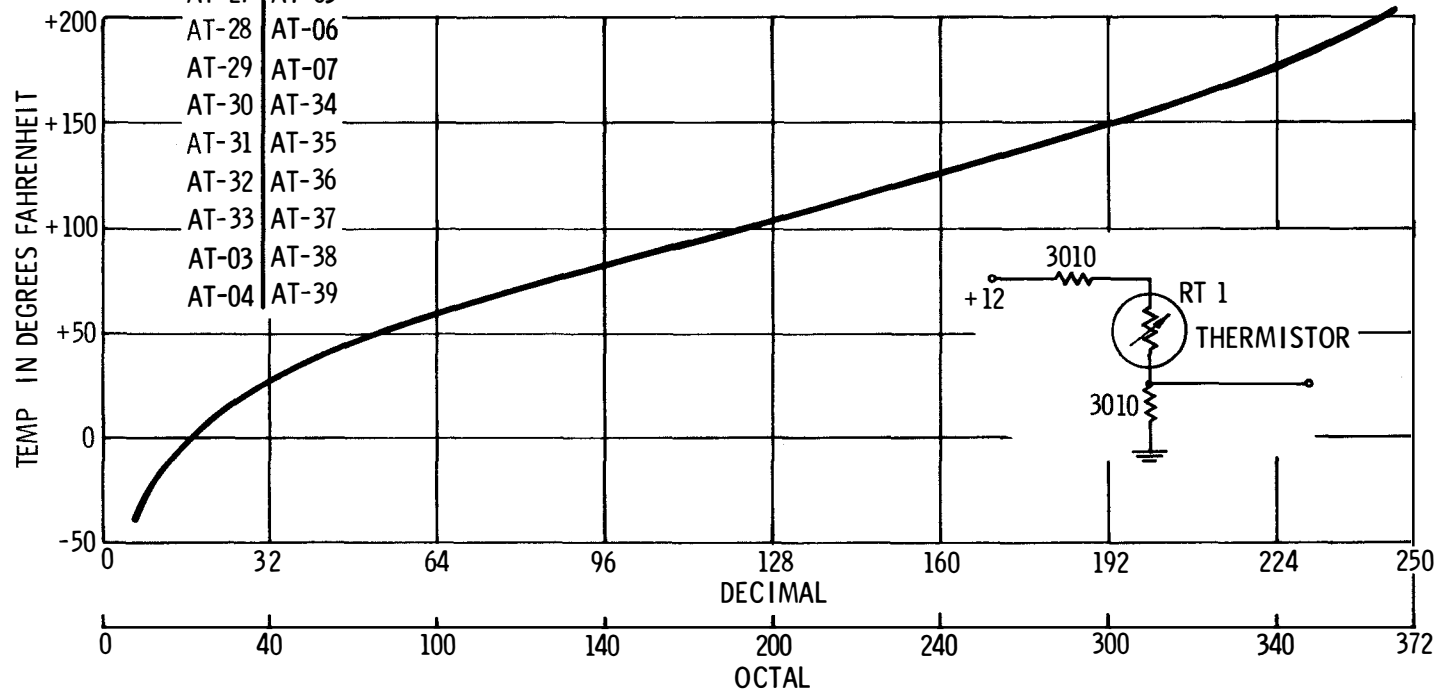

NOV 67 5178.7.44

ALSEP TELEMETRY LINK

- * DIGITAL DATA PROCESSOR (DDP)
- * MULTIPLEXER/CONVERTER
- * TRANSMITTERS (TWO)
- * DIPLEXER/SWITCH
- * ANTENNA

DEC 67 5178.7.45

DIGITAL DATA PROCESSOR

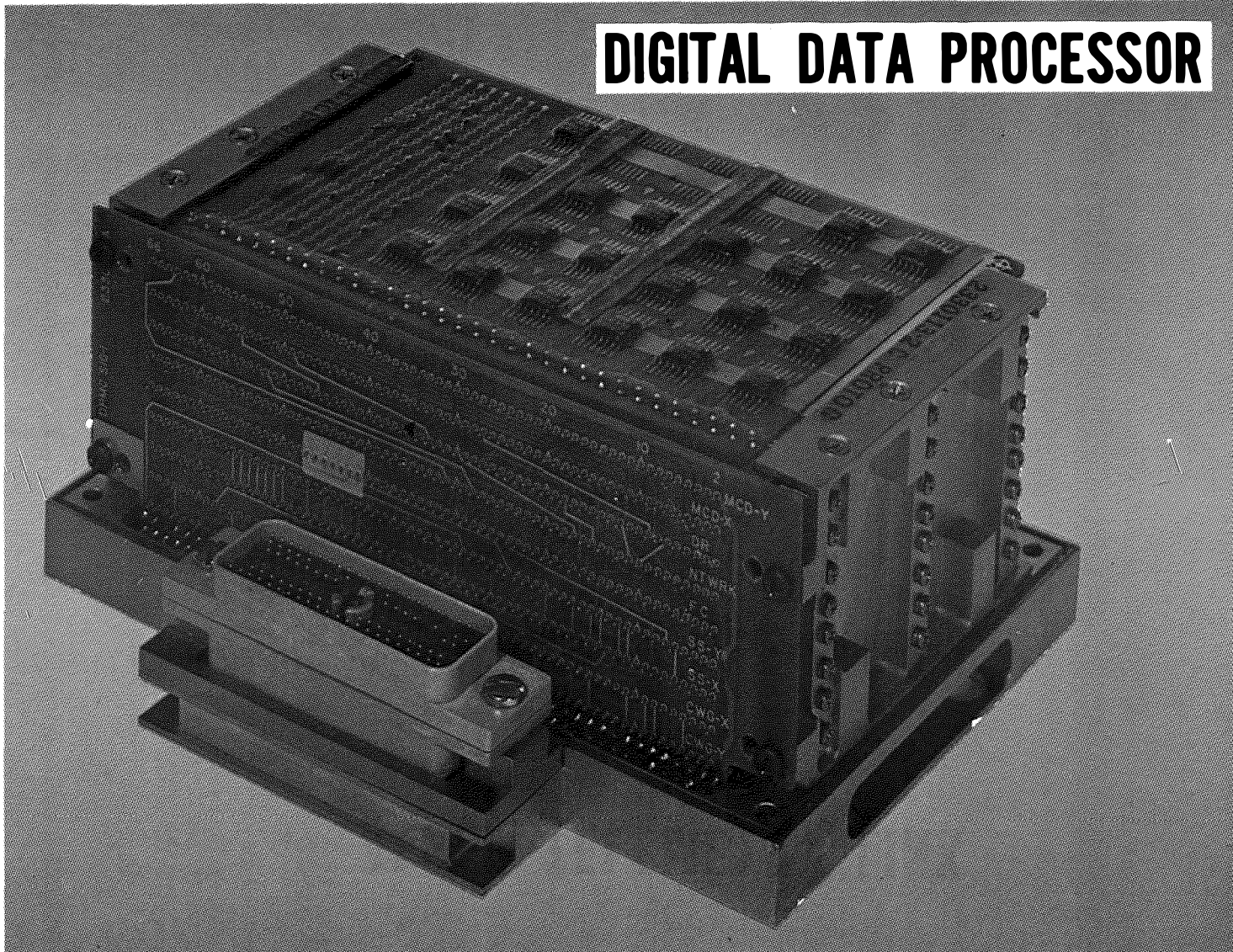

JAN 68 5178.7.46

DIGITAL DATA PROCESSOR

PHYSICAL DESCRIPTION -

SIZE - 2.8 X 3.94 X 6.25 INCHES

WEIGHT - 3.03 POUNDS

POWER - 450 MILLIWATTS AT 5 VDC

50 MILLIWATTS AT 12 VDC

(NOMINAL AT ROOM AMBIENT TEMPERATURE)

PARTS COUNT - 199 FLATPACKS

2 TRANSISTORS

41 RESISTORS

19 CAPACITORS

3 DIODES

PARTS ARE MOUNTED ON 9 PRINTED CIRCUIT BOARDS WITH
FROM 3 TO 12 LAYERS

CONNECTOR - HUGHES - 244 PIN

SEPT 68 5178.7.47

DIGITAL DATA PROCESSOR

THE DIGITAL DATA PROCESSOR -

- * IS THE FOCAL POINT FOR THE COLLECTION, FORMATTING AND CONTROL OF ALL TELEMETERED DATA
- * CONTAINS COMMAND SELECTABLE "X" AND "Y" SECTIONS. EXCEPT FOR THE FRAME COUNTER AND INTERFACE CIRCUITS, THE DDP IS FULLY REDUNDANT
- * HAS 3 MODES OF OPERATION DEFINED AS "NORMAL" (1060b/s), "SLOW" (530b/s) AND ACTIVE SEISMIC (10,600b/s)
- * USES A CRYSTAL OSCILLATOR TO DERIVE ALL TIMING AND CONTROL SIGNALS
- * COLLECTS DATA INTO A 64 WORD FRAME REPEATING EACH 604 MILLISECONDS. EACH WORD CONSISTS OF 10 BITS OR ABOUT 9.43 MILLISECONDS (NORMAL MODE)
- * PROCESSES COLLECTED DATA INTO THE REQUIRED TELEMETRY FORMAT IS SERIAL FORM. EACH DATA SOURCE IS SAMPLED AT LEAST ONCE PER FRAME

DEC 67 5178.7.48

DATA PROCESSOR SIMPLIFIED BLOCK DIAGRAM

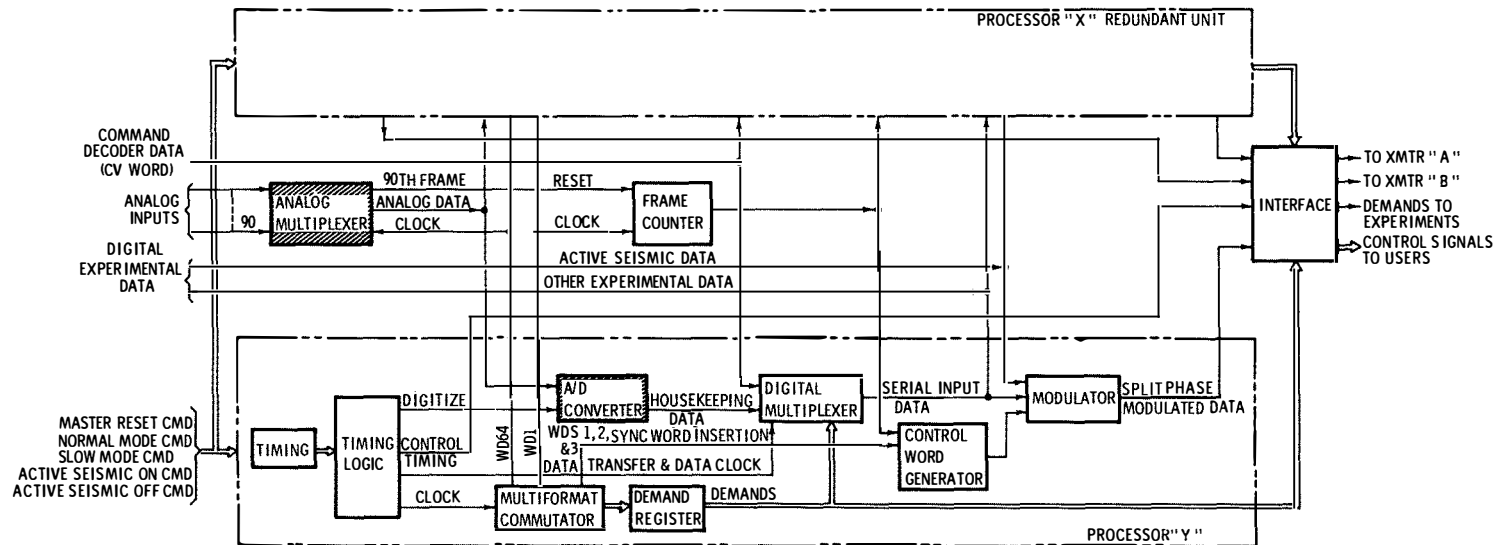

SEPT 68 5178.7.49

GENERATION OF BASIC CLOCKS

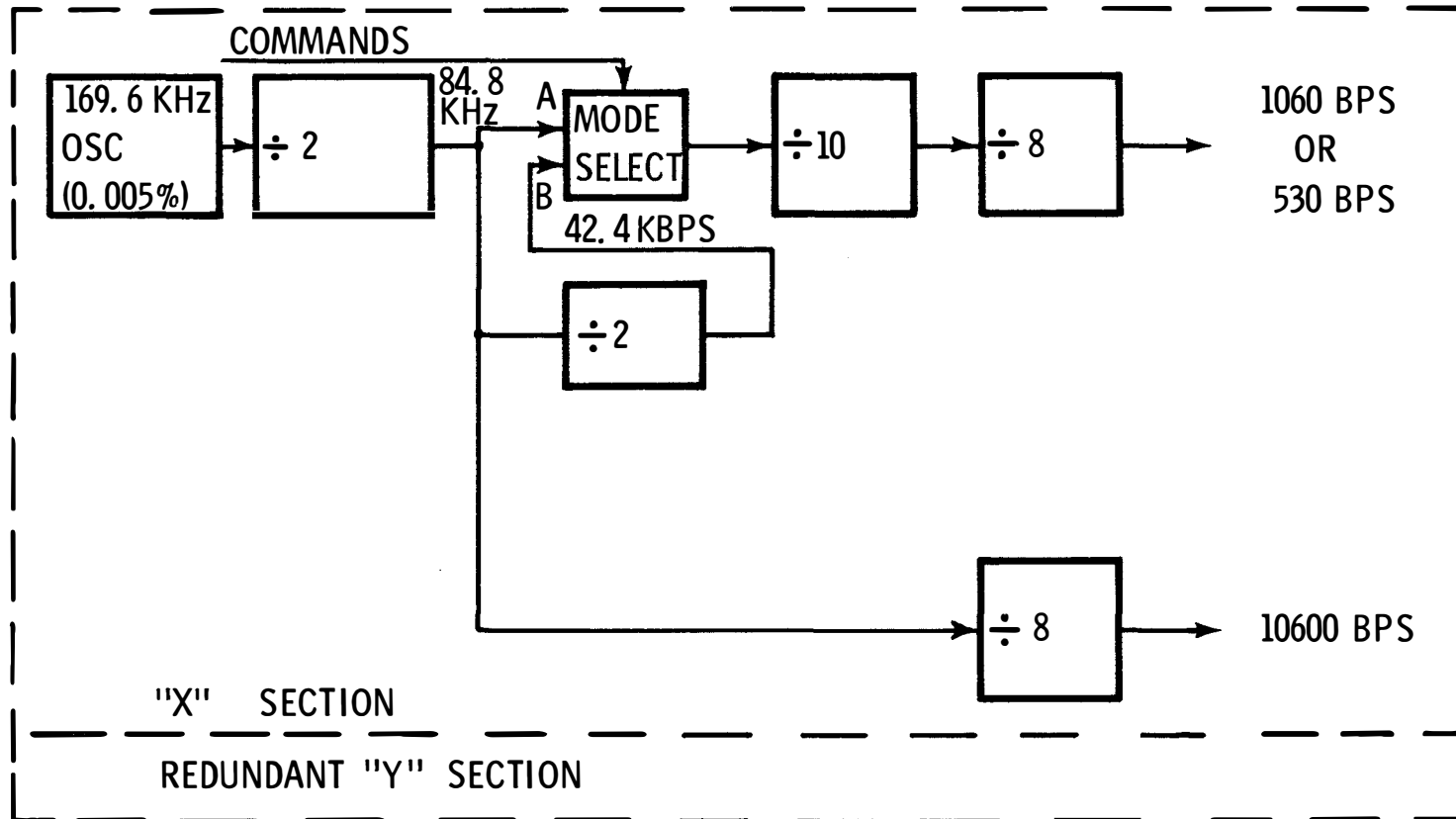

A - NORMAL MODE

B - SLOW MODE

APR 69 5178.7.50

DIGITAL DATA PROCESSOR

- * CONTROL WORD GENERATOR
 - GENERATES THE 22-BIT SYNCHRONIZATION CODE
 - PROVIDES MODE, FRAME AND ALSEP ID IN THE LAST 8 BITS OF THE 30-BIT SYNCH WORD
- * SPLIT PHASE MODULATOR
 - ENCODES DATA INTO INTO A "SPLIT PHASE" SIGNAL
 - PCM "0" IS REPRESENTED BY "01" AND CAUSES A POSITIVE PHASE TRANSITION
 - PCM "1" IS REPRESENTED BY A "10" AND CAUSES NEGATIVE PHASE TRANSITION
- * FRAME COUNTER
 - IS NOT REDUNDANT
 - CONTAINS A COUNTER WHICH IS ADVANCED ONE STEP PER 64 WORD FRAME
 - IS RESET BY A 90TH FRAME "END OF FRAME" SIGNAL FROM THE MULTIPLEXER/CONVERTER

DIGITAL DATA PROCESSOR

- * **MULTIFORMAT COMMUTATOR**
 - USES 2 DIVIDE-BY-8 COUNTERS WITH GATING FOR ANY ONE OF 64 CONSECUTIVE PERIODS (WORDS)
 - PRODUCES SIGNALS OF ONE WORD LENGTH AND MULTIPLES OF ONE WORD LENGTH TO SELECT AND GATE DATA INTO A MODULATOR
 - CONTAINS A "PATCH PLANE" FOR FLEXIBLE WORD ASSIGNMENTS
- * **DEMAND REGISTER**
 - ACTS AS A BUFFER BETWEEN THE DEMAND DECODER ASSEMBLY AND THE DEMAND LINES TO ELIMINATE GATING TRANSIENTS
 - ACTS AS A MASTER SWITCH TO INHIBIT ALL DEMANDS DURING ASE MODE
- * **DIGITAL MULTIPLEXER**
 - CONTAINS A 10-BIT SHIFT REGISTER TO ACCEPT 8 PARALLEL BITS FROM THE A/D CONVERTER OR 8 SERIAL BITS FROM THE COMMAND DECODER
 - SHIFTS OUT 10-BIT WORDS WITH "ZEROS" IN THE TWO MOST SIGNIFICANT FIGURES. BITS ARE SHIFTED HIGH ORDER FIRST

FORMAT FLIGHT SYSTEMS 1 & 2

1 x	2 x	3 x	4 x	5 0	6 x	7 S	8 x
9 -	10 x	11 -	12 x	13 -	14 x	15 I	16 x
17 0	18 x	19 0	20 x	21 0	22 x	23 S	24 x
25 -	26 x	27 -	28 x	29 -	30 x	31 I	32 x
33 H	34 x	35 ●	36 x	37 ●	38 x	39 S	40 x
41 -	42 x	43 -	44 x	45 -	46 CV	47 I	48 x
49 0	50 x	51 0	52 x	53 0	54 x	55 S	56 I
57 -	58 x	59 -	60 x	61 -	62 x	63 I	64 x

<u># OF WORDS PER FRAME</u>	<u>LEGEND</u>	<u>ASSIGNMENTS</u>
3	x	CONTROL
29	x	PASSIVE SEISMIC (SHORT PERIOD)
12	-	PASSIVE SEISMIC (LONG PERIOD SEISMIC)
2	●	PASSIVE SEISMIC (LONG PERIOD TIDAL + TEMP)
7	0	MAGNETOMETER
4	S	SOLAR WIND
5	I	SUPRATHERMAL ION DETECTOR/CCGE
0	HF	HEAT FLOW
0	CP	CHARGED-PARTICLE
1	CV	COMMAND VERIFICATION (ALL ZEROS IF NO COMMAND)
1	H	HOUSEKEEPING
	NA	NOT ASSIGNED (ALL ZEROS TRANSMITTED)
0	CG	COLD CATHODE GUAGE EXPERIMENT (MSC)

EACH BOX CONTAINS ONE 10 BIT WORD. TOTAL
REPRESENTS ONE FRAME OR 640 BITS.

SEPT 68 5178.7.53

TELEMETRY FORMAT FLEXIBLE WORD ASSIGNMENTS

1	2	3	4	5	6	7	8
9	10	11	12	13	14	15	16
17	18	19	20	21	22	23	24
25	26	27	28	29	30	31	32
33	34	35	36	37	38	39	40
41	42	43	44	45	46	47	48
49	50	51	52	53	54	55	56
57	58	59	60	61	62	63	64

WORDS MARKED WITH X ARE ASSIGNED BY DRAWING DURING FABRICATION OF THE DIGITAL DATA PROCESSOR'S MULTI-FORMAT COMMUTATOR.

NOV 67 5178.7.54

FORMAT FLIGHT SYSTEM #3

1 x	2 x	3 x	4 X	5 CV	6 X	7 CP	8 X
9 -	10 X	11 -	12 X	13 -	14 X	15 CG	16 X
17 CP	18 X	19 CP	20 X	21 HF	22 X	23 CP	24 X
25 -	26 X	27 -	28 X	29 -	30 X	31 CG	32 X
33 H	34 X	35 •	36 X	37 •	38 X	39 CP	40 X
41 -	42 X	43 -	44 X	45 -	46 X	47 CG	48 X
49 NA	50 X	51 NA	52 X	53 NA	54 X	55 CP	56 CG
57 -	58 X	59 -	60 X	61 -	62 X	63 CG	64 X

<u># OF WORDS PER FRAME</u>	<u>LEGEND</u>	<u>ASSIGNMENTS</u>
3	x	CONTROL
30	X	PASSIVE SEISMIC (SHORT PERIOD)
12	-	PASSIVE SEISMIC (LONG PERIOD SEISMIC)
2	•	PASSIVE SEISMIC (LONG PERIOD TIDAL + TEMP)
0	0	MAGNETOMETER
0	S	SOLAR WIND
0	I	SUPRATHERMAL ION DETECTOR/CCGE
1	HF	HEAT FLOW
6	CP	CHARGED PARTICLE
1	CV	COMMAND VERIFICATION (ALL ZEROS IF NO COMMAND)
1	H	HOUSEKEEPING
3	NA	NOT ASSIGNED (ALL ZEROS TRANSMITTED)
5	CG	COLD CATHODE GUAGE EXPERIMENT (MSC)

EACH BOX CONTAINS ONE 10 BIT WORD. TOTAL
REPRESENTS ONE FRAME OR 640 BITS.

SEPT 68 5178.7.55

FORMAT FLIGHT SYSTEM #4

1 x	2 x	3 x	4 x	5 CV	6 x	7 CP	8 x
9 -	10 x	11 -	12 x	13 -	14 x	15 I	16 x
17 CP	18 x	19 CP	20 x	21 NA	22 x	23 CP	24 x
25 -	26 x	27 -	28 x	29 -	30 x	31 I	32 x
33 H	34 x	35 ●	36 x	37 ●	38 x	39 CP	40 x
41 -	42 x	43 -	44 x	45 -	46 x	47 I	48 x
49 NA	50 x	51 NA	52 x	53 NA	54 x	55 CP	56 I
57 -	58 x	59 -	60 x	61 -	62 x	63 I	64 x

<u># OF WORDS PER FRAME</u>	<u>LEGEND</u>	<u>ASSIGNMENTS</u>
3	x	CONTROL
30	X	PASSIVE SEISMIC (SHORT PERIOD)
12	-	PASSIVE SEISMIC (LONG PERIOD SEISMIC)
2	●	PASSIVE SEISMIC (LONG PERIOD TIDAL + TEMP)
0	0	MAGNETOMETER
0	S	SOLAR WIND
5	I	SUPRATHERMAL ION DETECTOR/CCGE
0	HF	HEAT FLOW
6	CP	CHARGED PARTICLE
1	CV	COMMAND VERIFICATION (ALL ZEROS IF NO COMMAND)
1	H	HOUSEKEEPING
4	NA	NOT ASSIGNED (ALL ZEROS TRANSMITTED)
0	CG	COLD CATHODE GUAGE EXPERIMENT (MSC)

EACH BOX CONTAINS ONE 10 BIT WORD. TOTAL
REPRESENTS ONE FRAME OR 640 BITS.

SEPT 68 5178.7.56

ALSEP DATA FORMAT

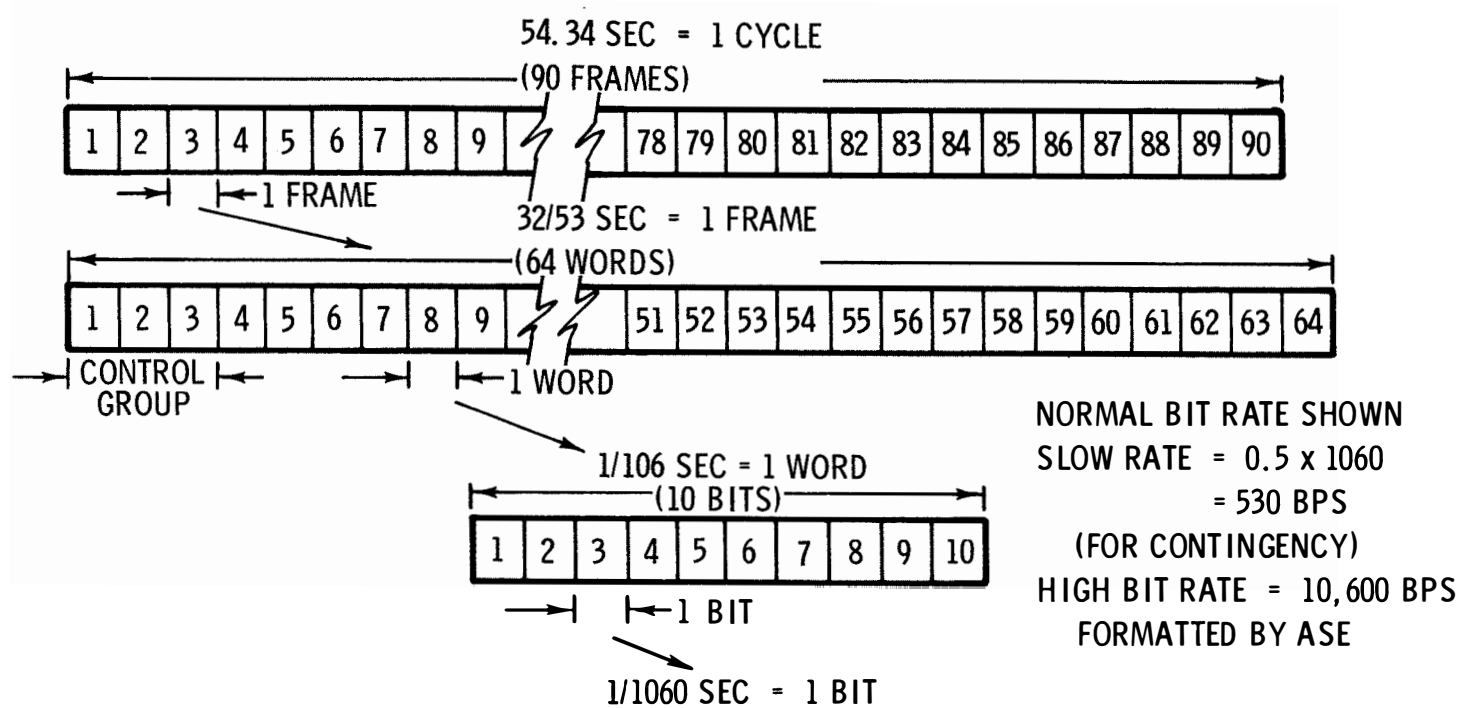

CONTROL WORDS AND CMD VERIFICATION

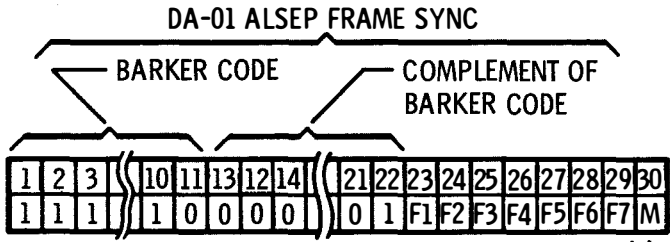

DA-02 ALSEP FRAME CNTR
(1, 2... 89, 0)

MODE BIT, DEFINED AS FOLLOWS:

FRAME	MODE BIT	MEANING
1	1	NORMAL BIT RATE
2	1	LOW BIT RATE
3	X MSB	DATA PROC ID NO.
4	X	
5	X	
6	NONE	NONE
•	"	"
•	"	"
•	"	"
89	"	"
0	NONE	NONE

DA-03 ALSEP BIT RT ID (frames 1, 2)

DA-04 ALSEP ID (frames 3, 4)

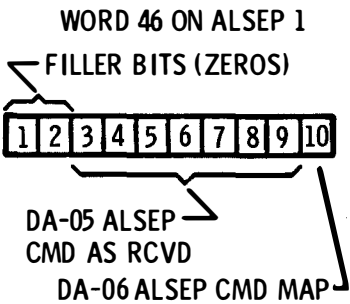

ONE WORD SAMPLE AS EACH COMMAND IS RECEIVED AT ALSEP, AT OTHER TIMES THE SAMPLE IS ALL ZEROS

ALSEP 1 DATA COMMUTATION

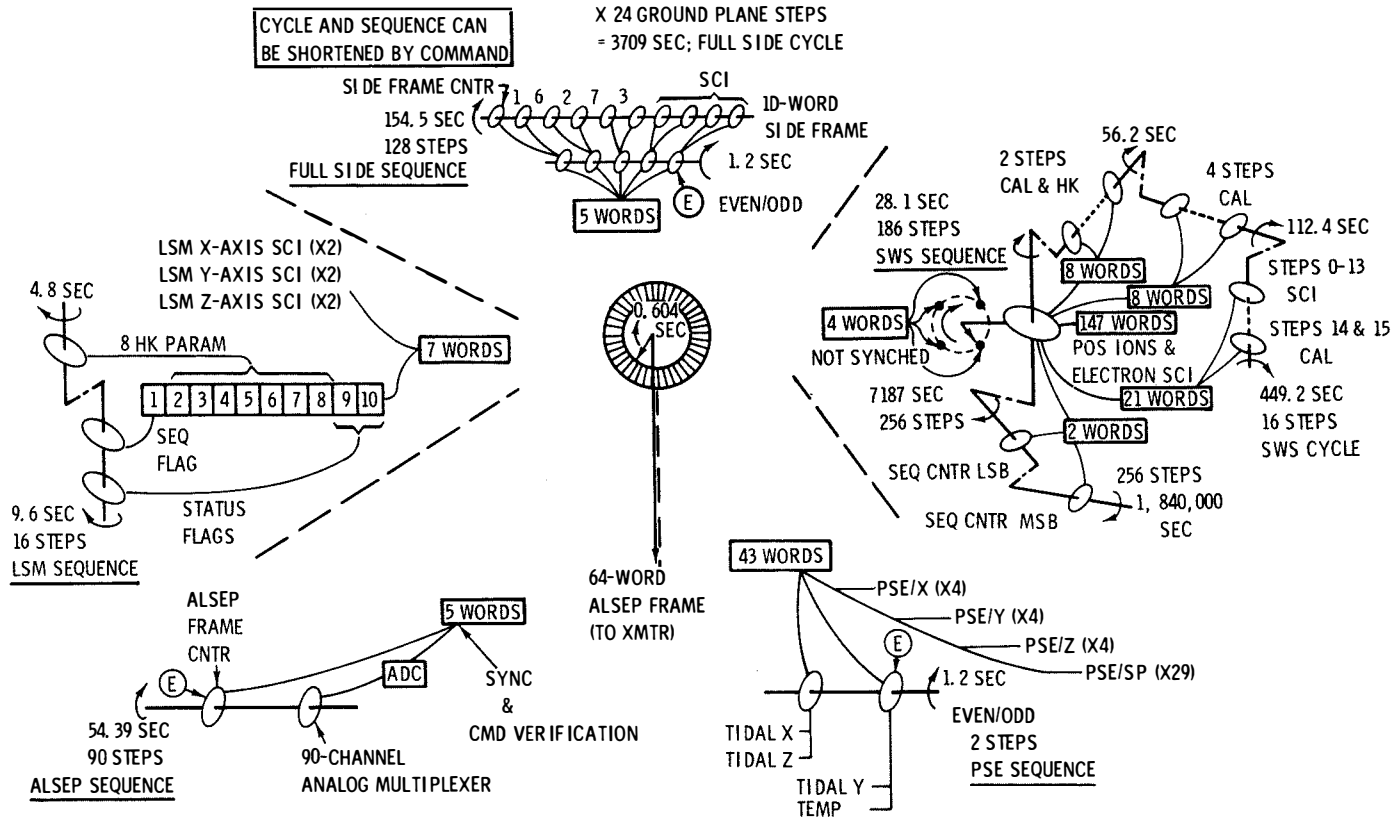

NOTE: TIMES ARE FOR NORMAL BIT RATE

SEPT 68 5178.7.59

DATA PROCESSOR TIMING/CONTROL SIGNALS

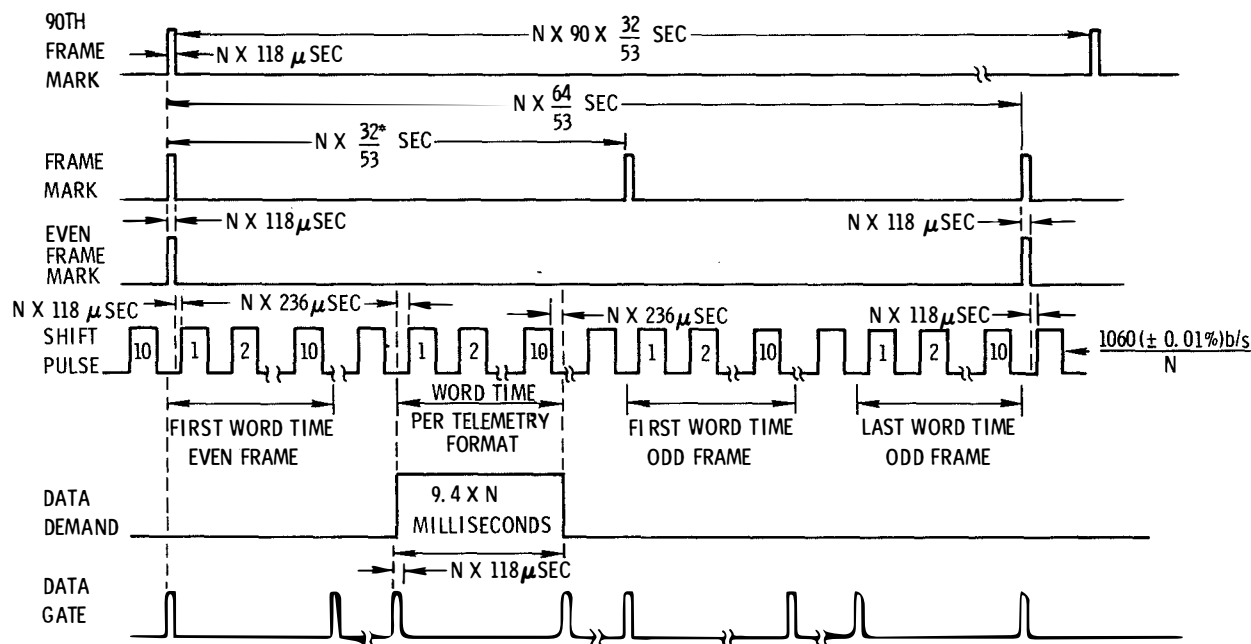

N = 1 FOR NORMAL MODE OF 1060 bps

N = 2 FOR SLOW MODE OF 530 bps

LOGIC LEVELS:"ONE", + 4.0 ± 1.5 VOLTS;"ZERO", + 0.2 ± 0.2 VOLTS

* $\frac{32}{53} \text{ SEC} = \frac{640 \text{ BITS PER FRAME}}{1060 \text{ bps}}$ ALL OTHER TIMES ARE ACCURATE ONLY TO THE SIGNIFICANT FIGURE SHOWN.

DEC 67 5178.7.60

TIMING/CONTROL SIGNAL INTERFACE

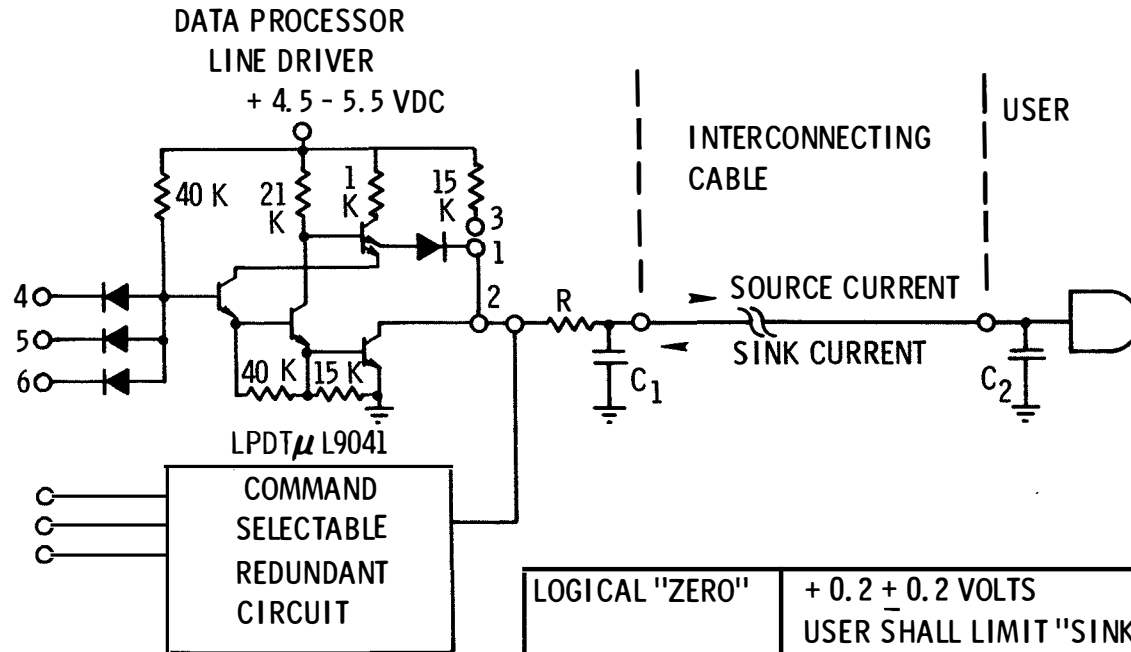

LOGICAL "ZERO"	+ 0.2 ± 0.2 VOLTS USER SHALL LIMIT "SINK" CURRENT TO 0.75 ma OR LESS
LOGICAL "ONE"	+ 4.0 ± 1.5 VOLTS USER SHALL LIMIT "SOURCE" CURRENT TO 0.045 ma OR LESS
R, C ₁ & C ₂	CONTROL RISE AND FALL TIME

EXPERIMENT/DATA PROCESSOR INTERFACE

DIGITAL DATA

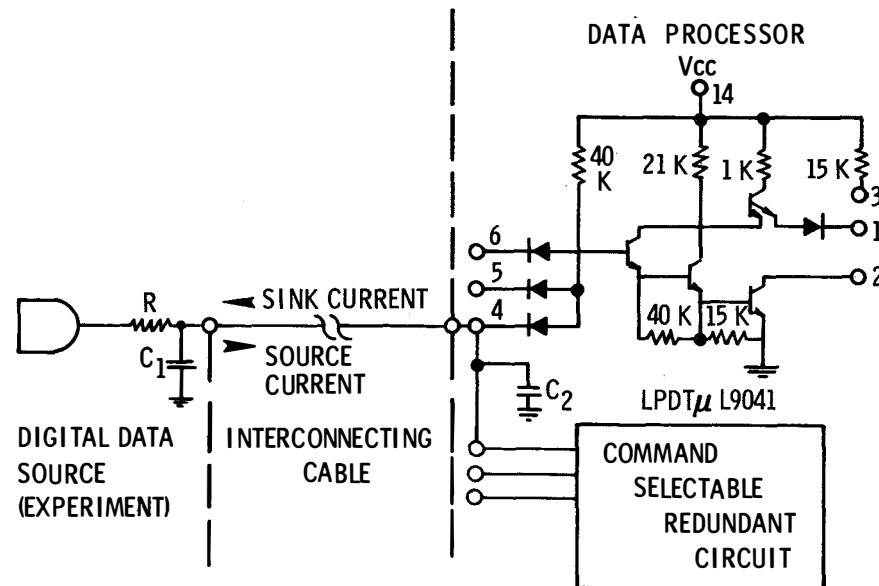

LOGICAL "ZERO"	+ 0.2 \pm 0.2 VOLTS THE SOURCE LINE DRIVER MUST BE CAPABLE OF "SINKING" UP TO 0.215 ma
LOGICAL "ONE"	+ 4.0 \pm 1.5 VOLTS THE SOURCE LINE DRIVER MUST BE CAPABLE OF "SOURCING" UP TO 0.012 ma
R, C1, & C2	CONTROL RISE AND FALL TIME

DIGITAL DATA PROCESSOR TELEMETRY SUMMARY

CHANNEL 2	AE-01	0.25 VDC CALIBRATION OF ADC A ZENER DIODE AND RESISTIVE DIVIDER IS USED TO PROVIDE AN ACCURATE REFERENCE VOLTAGE FOR TM CHANNEL CALIBRATION
CHANNEL 3	AE-02	4.75 VDC CALIBRATION OF ADC THIS VOLTAGE IS OBTAINED FROM THE SAME NETWORK AS THE 0.25 VDC AND PROVIDES A SECOND CALIBRATION POINT
CHANNEL 46	AT-29	DIGITAL DP, BASE TEMPERATURE USES A THERMISTOR LOCATED ON THE BASE PLATE
CHANNEL 47	AT-30	DIGITAL DP, INTERNAL TEMPERATURE USES A THERMISTOR LOCATED ON ONE OF THE PRINTED CIRCUIT BOARDS

SEPT 68 5178.7.63

ANALOG MULTIPLEXER CONVERTER

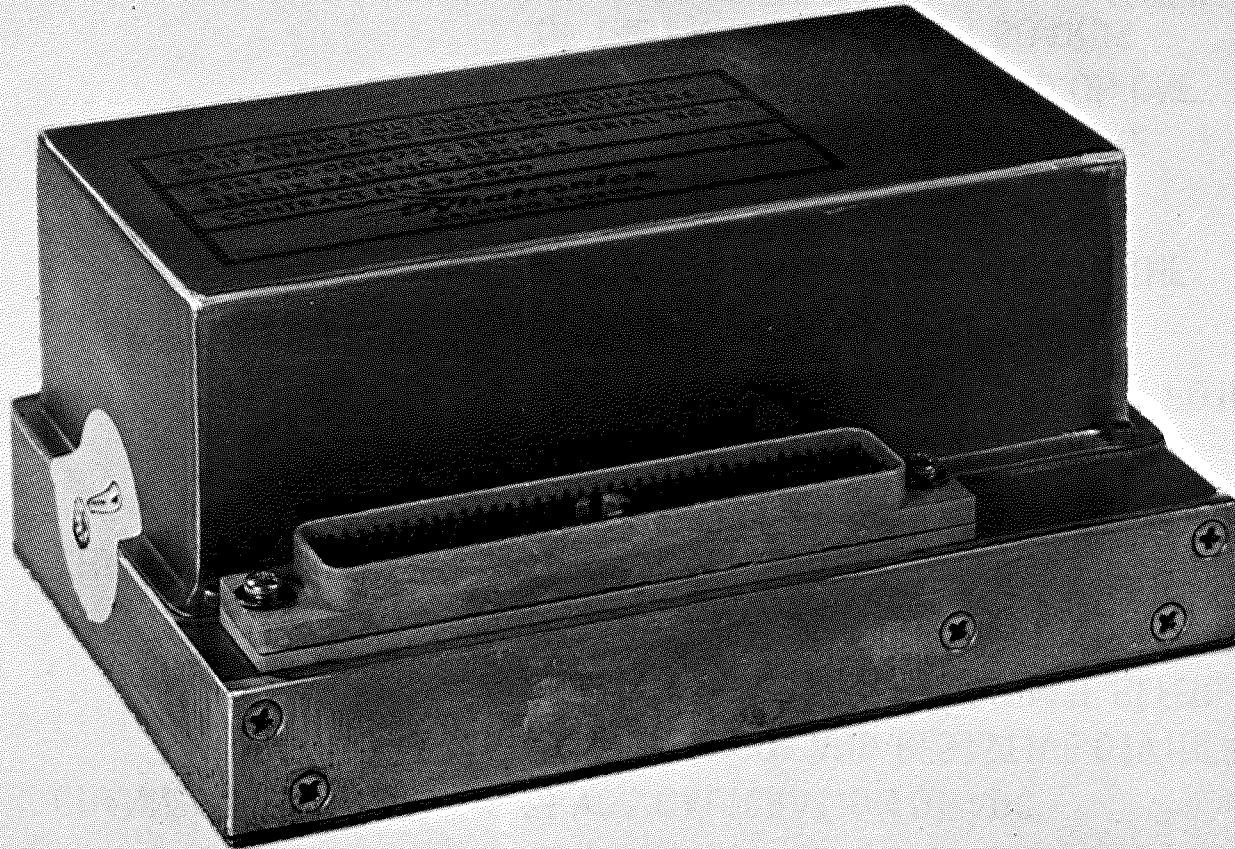

DEC 67 5178.7.64

ANALOG MULTIPLEXER/CONVERTER

PHYSICAL DESCRIPTION

SIZE 2.62 x 4.23 x 5.92 inches

WEIGHT 2.2 pounds

POWER REQUIRES A TOTAL OF 1435 MILLIWATTS (NOMINAL AT ROOM AMBIENT) AT THE FOLLOWING VOLTAGE LEVELS-

- 65 milliwatts at + 15 vdc
- 150 milliwatts at + 12 vdc
- 1100 milliwatts at + 5 vdc
- 120 milliwatts at - 12 vdc

PARTS COUNT

INTEGRATED CIRCUITS	76
FIELD EFFECT TRANSISTORS	156
TRANSISTORS	185
DIODES	307
ZENER DIODES	9
CAPACITORS	158
RESISTORS	102
CRYSTALS	2

PACKAGING ALL PARTS ARE MOUNTED ON 15 TWO LAYER PCBs

CONNECTOR HUGHES - 244 PIN

DEC 67 5178.7.65

ANALOG MULTIPLEXER/CONVERTER

THE COMPONENT -

- CONSISTS OF A 90 CHANNEL ANALOG MULTIPLEXER, A SEQUENCER, BUFFER AMPLIFIERS AND TWO EIGHT-BIT A/D CONVERTERS WITH BUFFERED OUTPUTS
- USES REDUNDANT GATES, DRIVERS AND A/D CONVERTERS FOR RELIABLE OPERATION
- MONITORS UP TO 90 DATA SOURCES ON A SEQUENTIAL SAMPLE BASIS. REQUIRES ABOUT 54 SECONDS FOR ONE COMPLETE SEQUENCE OF SAMPLES
- CONVERTS EACH INPUT INTO AN 8-BIT BINARY WORD
- PROVIDES THE 8-BIT BINARY WORD IN PARALLEL TO THE DIGITAL MULTIPLEXER OF THE DDP

SIMPLIFIED BLOCK DIAGRAM

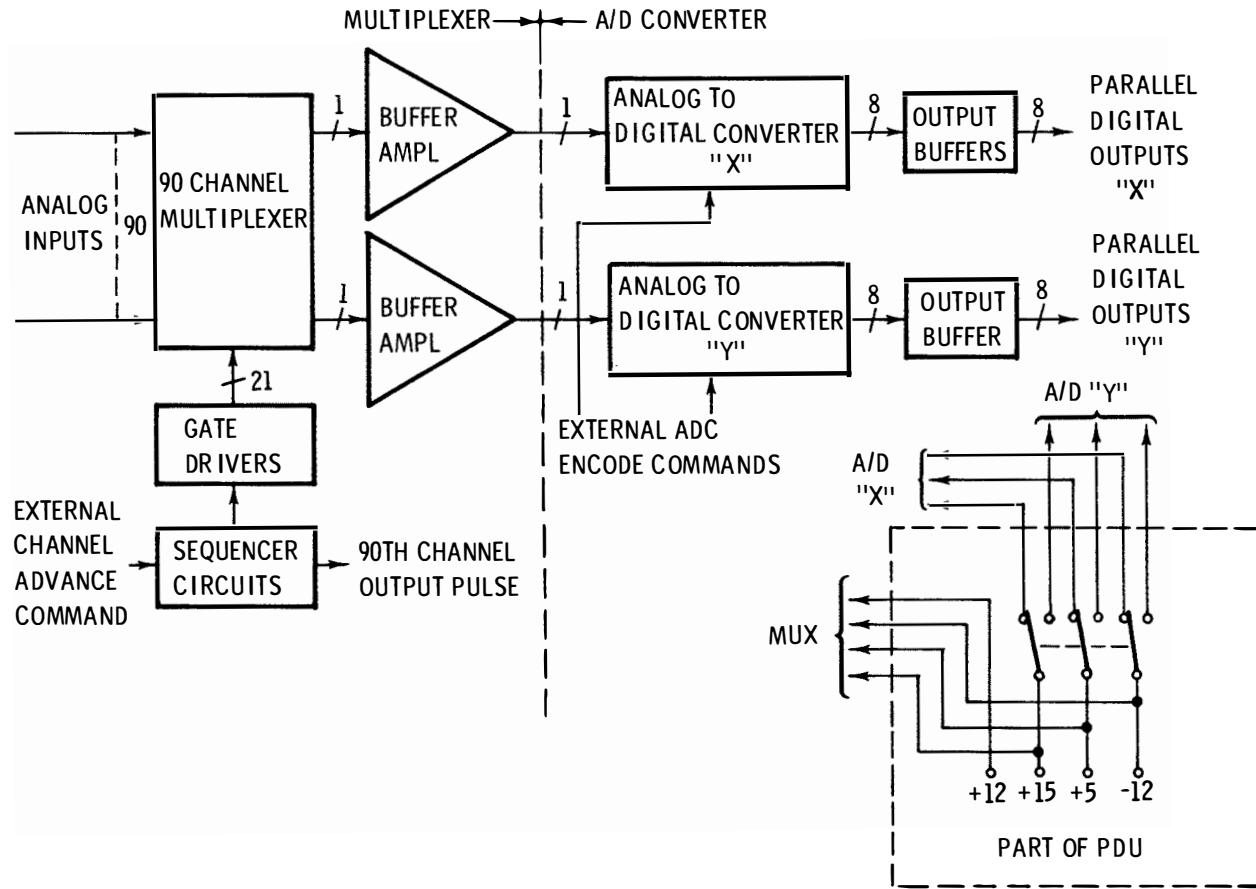

MULTIPLEXER GATE ARRANGEMENT DIAGRAM

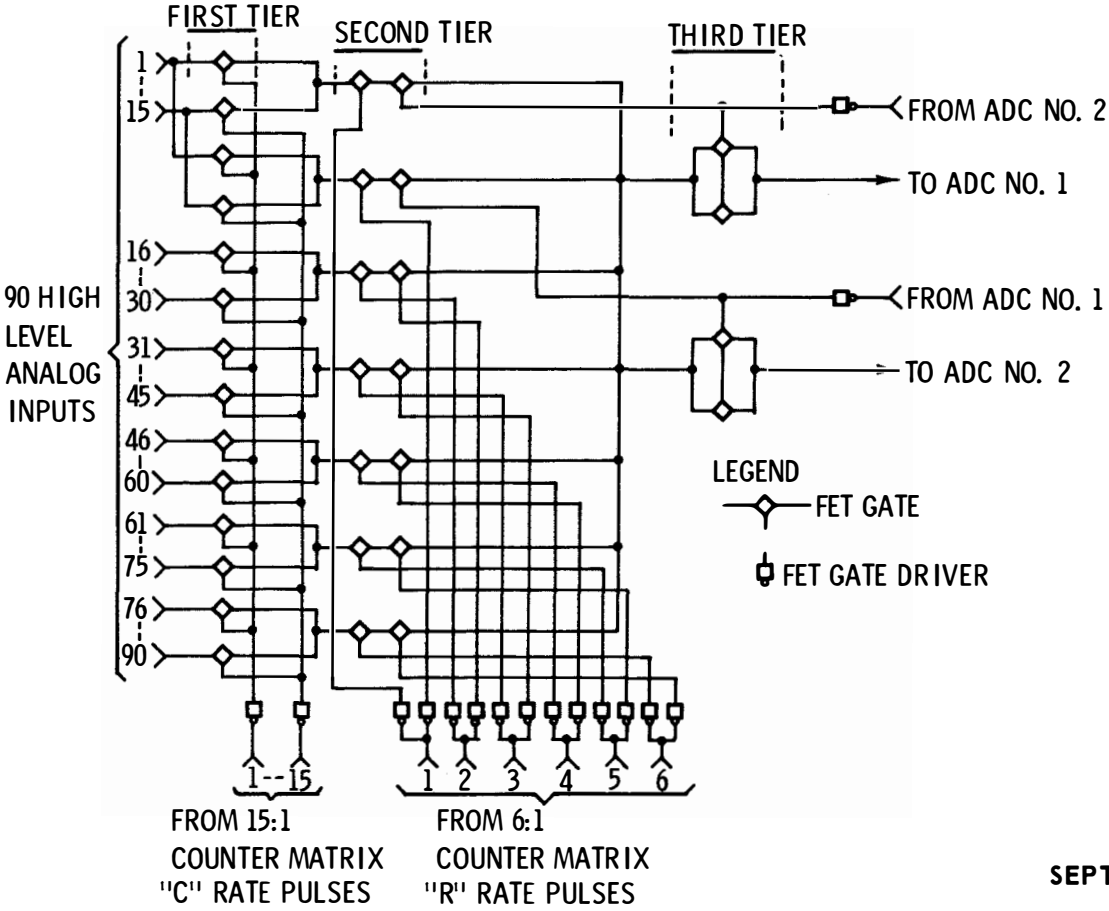

MULTIPLEXER TIMING DIAGRAM

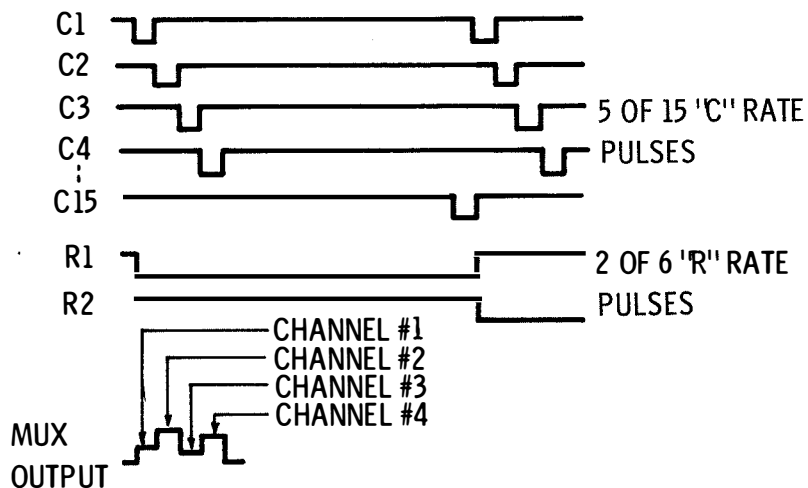

	C1	C2	C3	C4	C5	C6	C7	C8	C9	C10	C11	C12	C13	C14	C15
R1	1	2	3	4	5	6	7	8	9	10	11	12	13	14	15
R2	16														30
R3	31														45
R4	46														60
R5	61														75
R6	76														90

DATA FORMAT AND CHANNEL SEQUENCE

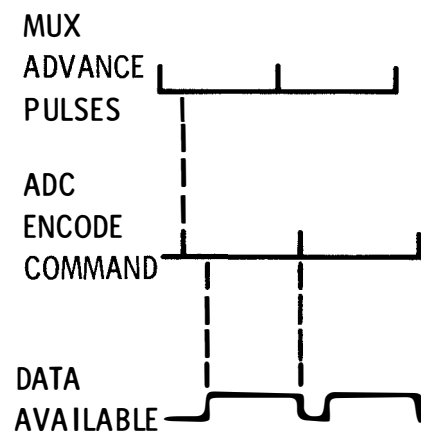

A/D CONVERTER FUNCTIONAL BLOCK DIAGRAM

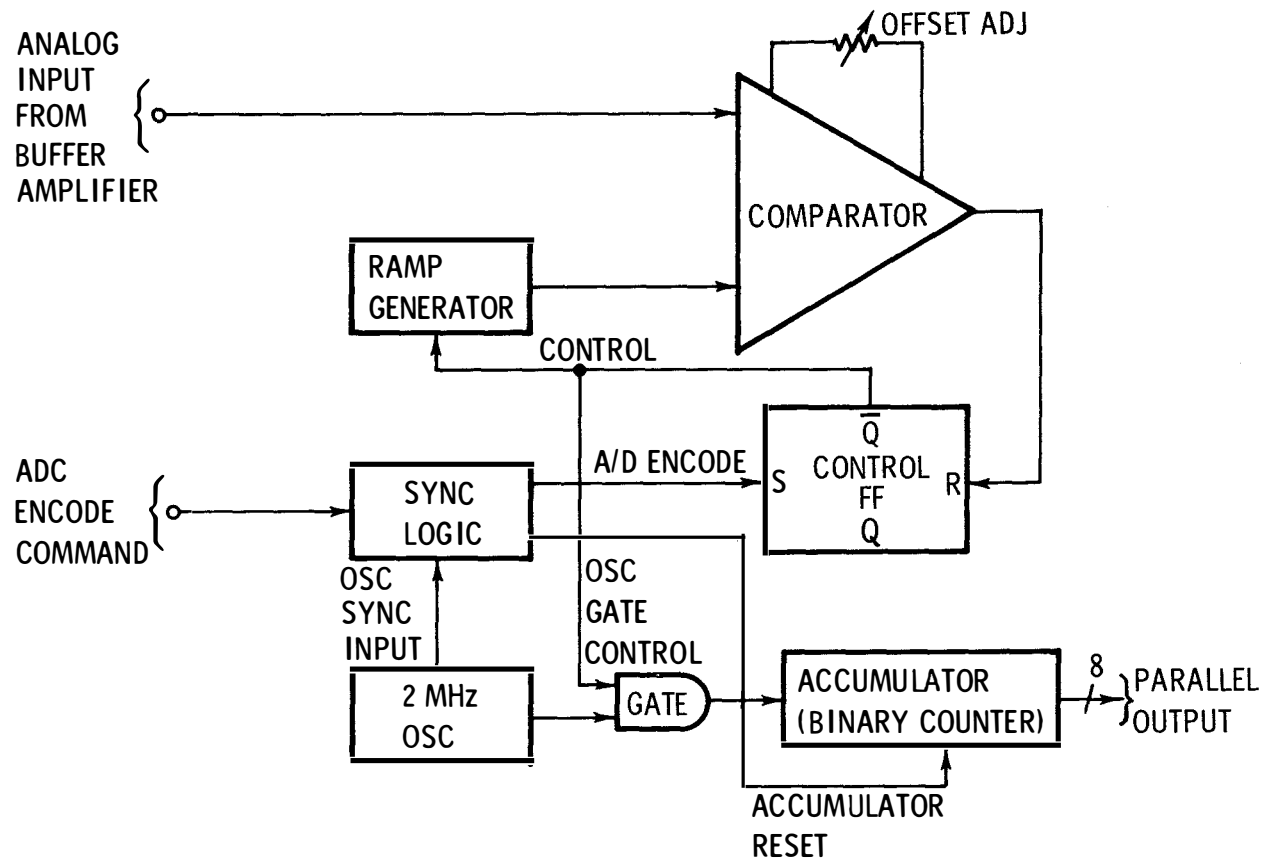

SEPT 68 5178.7.70

INPUT REQUIREMENTS

ANALOG INPUTS

RANGE 0 TO +5 volts
INPUT Z ≥ 1 megohm (ON state)
 ≥ 50 megohms (OFF state)
SOURCE Z ≤ 10 k ohms

* PROPER OPERATION WITH AN OVERVOLTAGE OF

+8 to -6.5 volts for channels 21, 36, 45, & 80

+8 to -9 volts for channels 6, 7, 26, 52, 67, & 70

+8 to -5 volts for all other channels

IS NOT DAMAGED BY AN OVERVOLTAGE OF ± 12 VOLTS ON ANY CHANNEL.

ADVANCE PULSE

REQUIRED FOR ADVANCING MULTIPLEXER THROUGH ITS 90 CHANNELS.
SUPPLIED BY DDP

ADC START (ENCODE) PULSE

DRIVES SYNC LOGIC TO START A/D CONVERSION. SUPPLIED BY DDP

* PROPER OPERATION IS NOT GUARANTEED BEYOND
PLUS AND MINUS OPERATIONAL LIMITS

APR 69 5178.7.71

ANALOG MULTIPLEXER/CONVERTER OUTPUTS

BINARY OUTPUT -

00000000	FOR A NEGATIVE INPUT
00000001	FOR ZERO INPUT
11111110	FOR +5 VOLTS INPUT
11111111	FOR GREATER THAN +5 VOLTS INPUT

LOGICAL "0" IS $+4.0 \pm 1.5$ VOLTS
LOGICAL "1" IS $+0.2 \pm 0.2$ VOLTS













TEMPERATURE TELEMETRY

CHANNEL 33	AT-27	BASE TEMP (SIGNAL OBTAINED BY A THERMISTOR/ RESISTOR NETWORK POWERED BY +12 VDC THERMISTOR LOCATED ON BASE PLATE)
CHANNEL 34	AT-28	INTERNAL TEMP (SAME AS ABOVE EXCEPT THERMISTOR MOUNTED ON PCB)

ANALOG MULTIPLEXER CHANNEL ASSIGNMENTS



APPEARS IN WORD 33 ON ALSEP 1

-  STRUCTURE & INSULATION TEMPERATURES (13)
-  DUST CELLS (6)
-  RTG TEMPERATURES (6)
-  PCU TEMPERATURES (4)
-  PCU INPUT/OUTPUT (10)
-  DATA SUBSYSTEM TEMPERATURES (15)
-  DATA SUBSYSTEM FUNCTIONAL (11)
-  PSE (8)
-  SIDE/CCGE (2)
-  CPLEE (6)
-  HEAT FLOW (6)/ASE (4)
-  BLANK (1)

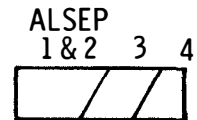

SEPT 68 5178.7.73

TRANSMITTER

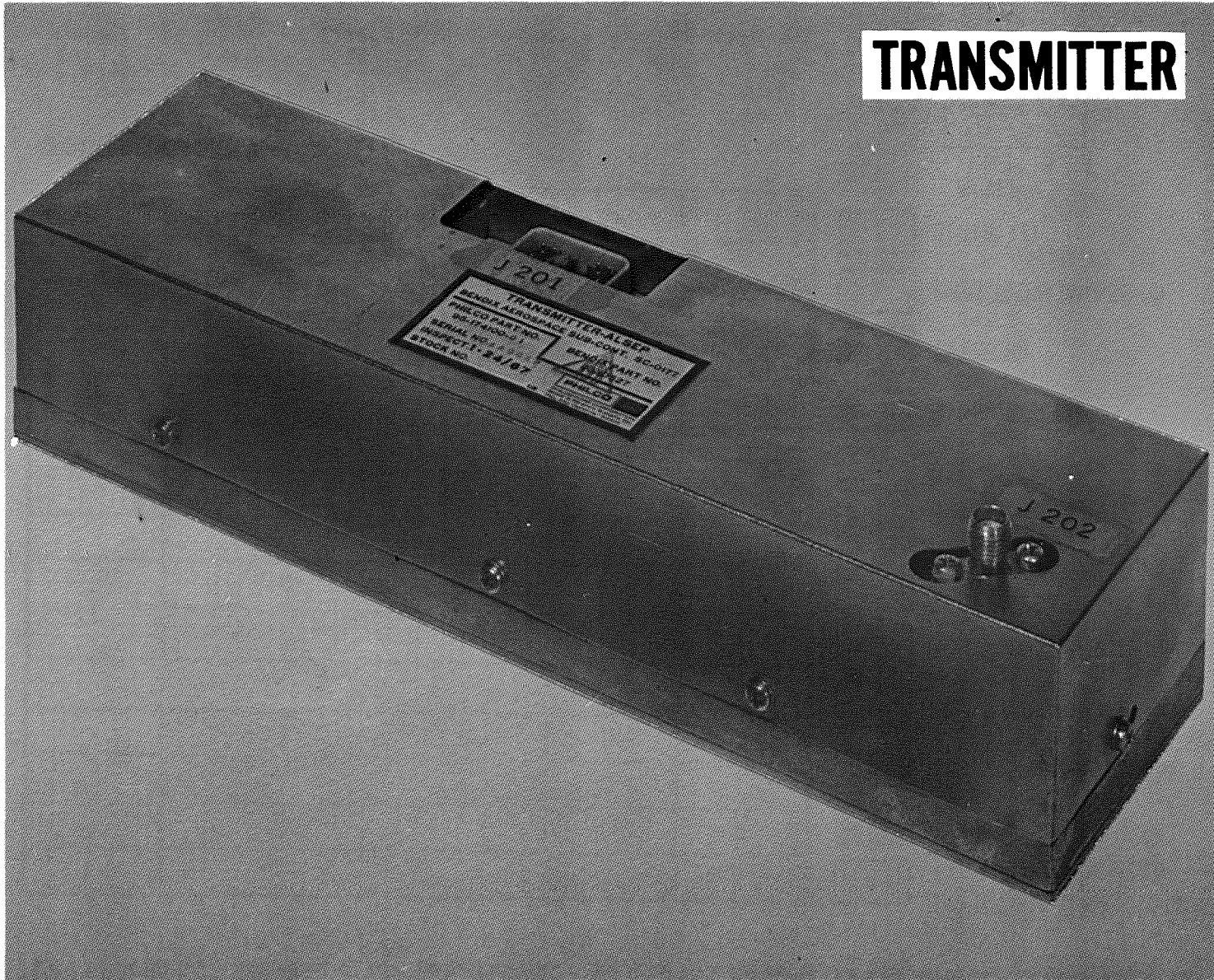

DEC 67 5178.7.74

TRANSMITTER

PHYSICAL DESCRIPTION

- SIZE 1.5 x 2 x 7.5 inches
- WEIGHT 1.17 pounds (each)
- POWER 8 watts at 29 VDC
0.5 watts at 12 VDC
- EMPLOYS MODULAR CONSTRUCTION WITH 11 SEPARATE CIRCUIT
MODULES
- MODULES ARE MOUNTED ON A MILLED MAGNESIUM BASE PLATE
WITH INTER-MODULE WIRING THROUGH MILLED PASSAGEWAYS

SEPT 68 5178.7.75

TRANSMITTER

- * PROVIDES A MINIMUM OF 1 WATT INTO A 50 OHM LOAD WITH A MAXIMUM VSWR OF 1.3:1
- * PROPER CRYSTAL IS INSTALLED DURING MANUFACTURE FOR OPERATION ON EITHER 2276.5 MHz (CHANNEL #1), 2278.5 MHz (CHANNEL #2) OR 2275.5 MHz (CHANNEL #3). 2279.5 MHz (CHANNEL #4) IS ASSIGNED BUT NOT IMPLEMENTED
- * FREQUENCY STABILITY IS 0.0025%/YEAR
- * TWO IDENTICAL COMPONENTS, TRANS A AND TRANS B, ARE PROVIDED WITH ONE IN STANDBY
- * EITHER A OR B MAY BE SELECTED BY COMMAND FROM THE MSFN
- * IF ONE IS SWITCHED "OFF" DUE TO AN OVERCURRENT CONDITION, THE OTHER IS AUTOMATICALLY SWITCHED "ON"
- * IF COMMANDED "OFF" A RESISTOR (HEATER) IS AUTOMATICALLY SWITCHED ON FOR CENT STA THERMAL STABILITY

SEPT 68 5178.7.76

TRANSMITTER, BLOCK DIAGRAM

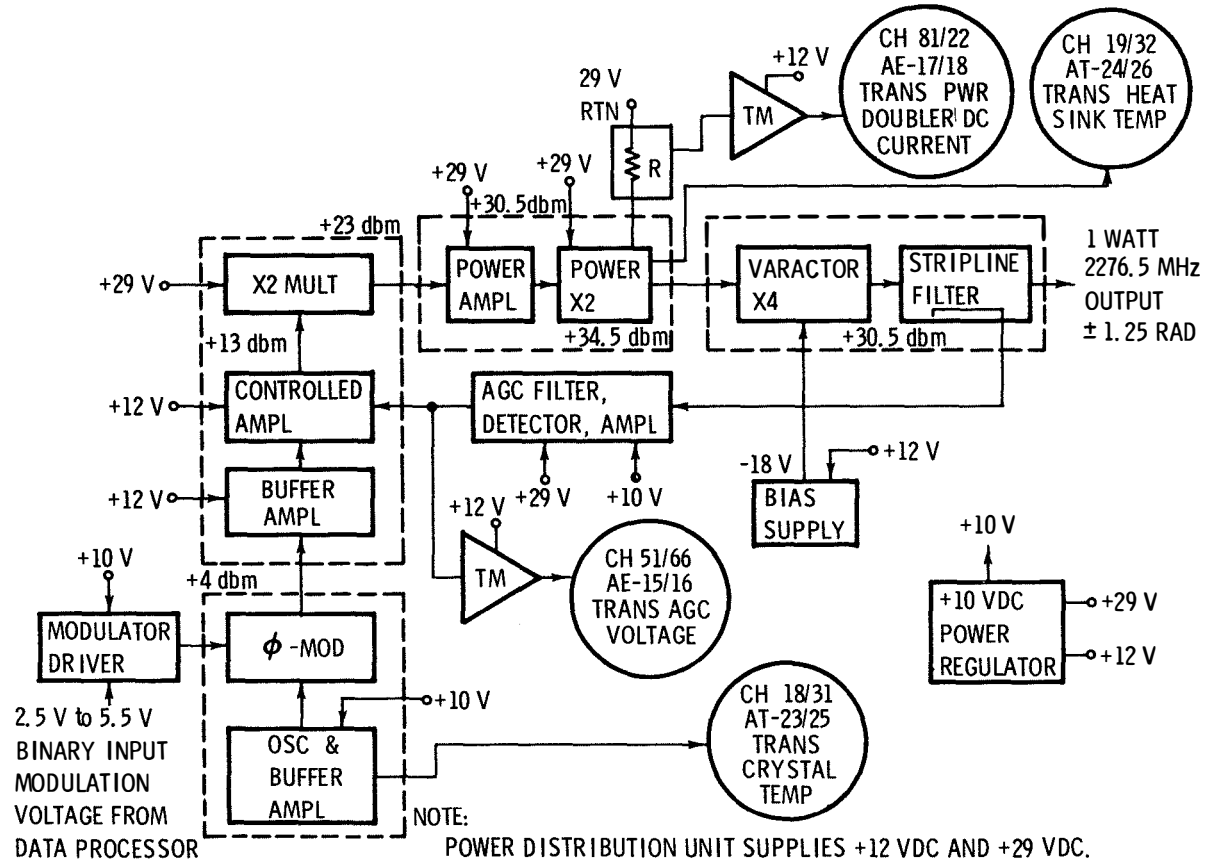

SEPT 68 5178.7.77

TRANSMITTER TELEMETRY SUMMARY

TRANSMITTER A		TELEMETRY DATA	TRANSMITTER B	
CHANNEL	SYMBOL		CHANNEL	SYMBOL
18	AT-23	TRANSMITTER CRYSTAL TEMP USES A 15 K OHM THERMISTOR AND 2 RESISTORS TO DEVELOP SIGNAL. PARTS ARE LOCATED IN OSC -BUFFER- MODULATOR MODULE	31	AT-25
19	AT-24	TRANSMITTER HEAT SINK TEMP USES A 15 K OHM THERMISTOR AND 2 RESISTORS TO DEVELOP SIGNAL. LOCATED IN POWER DOUBLER	32	AT-26
51	AE-51	TRANS AGC VOLTAGE AGC VOLTAGE IS AMPLIFIED TO GIVE TM SIGNAL OF PROPER LEVEL	66	AE-16
81	AE-17	TRANS PWR DOUBLER DC CURRENT SIGNAL OBTAINED FROM SMALL RE- SISTOR IN POWER RETURN	22	AE-18

APR 69 5178.7.78

POWER CONDITIONING UNIT

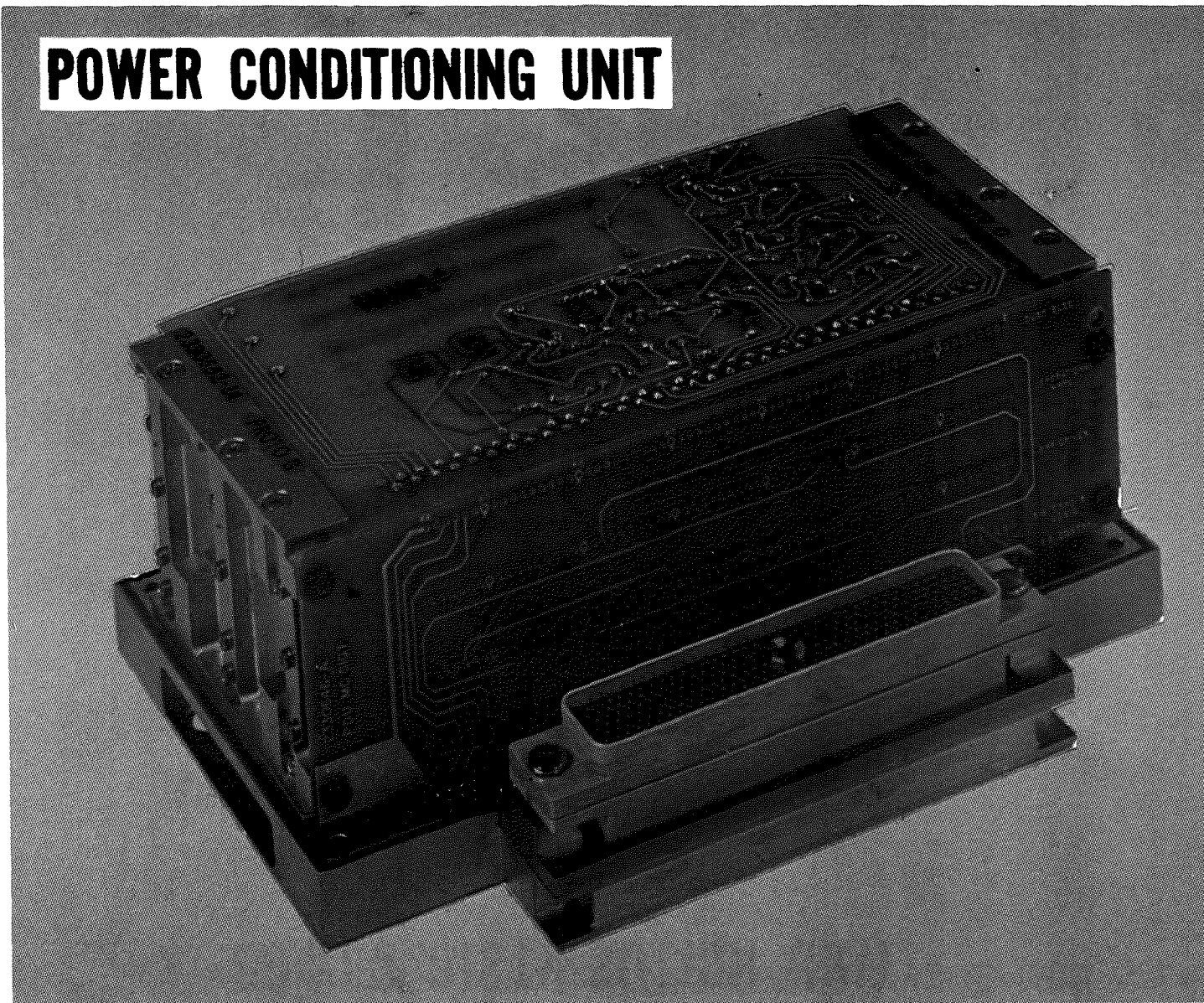

DEC 67 5178.7.79

POWER DISTRIBUTION UNIT

PHYSICAL DESCRIPTION OF THE PDU

- * SIZE 2.8 x 4 x 7.25 inches
- * WEIGHT 2.29 pounds
- * POWER 375 milliwatts at +29 VDC
75 milliwatts at +15 VDC
735 milliwatts at +12 VDC
85 milliwatts at + 5 VDC
8 milliwatts at - 6 VDC
475 milliwatts at -12 VDC
- * PARTS COUNT - 17 FLATPACKS 238 RESISTORS
37 TRANSISTORS 44 CAPACITORS
11 AMPLIFIERS 7 FUSES
98 DIODES 2 THERMISTORS
27 RELAYS
- * PACKAGING - ALL PARTS ARE MOUNTED ON 5 PCBs
- * CONNECTOR - HUGHES - 244 PIN

SEPT 68 5178.7.80

POWER DISTRIBUTION UNIT

THE PDU -

- PROVIDES FOR THE DISTRIBUTION AND CONTROL OF POWER TO EXPERIMENTS AND CENT STA COMPONENTS
- CONTAINS CIRCUITRY TO PROTECT THE SYSTEM AGAINST OVERLOADS OCCURRING FROM COMPONENT FAILURES
- PROVIDES SIGNAL CONDITIONING FOR CENT STA AND POWER SUBSYSTEM TELEMETRY SIGNALS
- WILL, BY SEQUENTIAL TURN-OFF OF 3 EXPERIMENTS, ADJUST THE TOTAL POWER DEMAND TO A VALUE WITHIN THE AVAILABLE POWER LIMIT
- UPON SENSING A POWER OVERLOAD CONDITION, WAITS ABOUT 135 MILLISECONDS BEFORE SWITCHING AN EXPERIMENT TO STANDBY
- PROVIDES MOUNTING SPACE FOR THE "DUST DETECTOR" ELECTRONICS

DEC 67 5178.7.81

SIMPLIFIED BLOCK DIAGRAM PDU

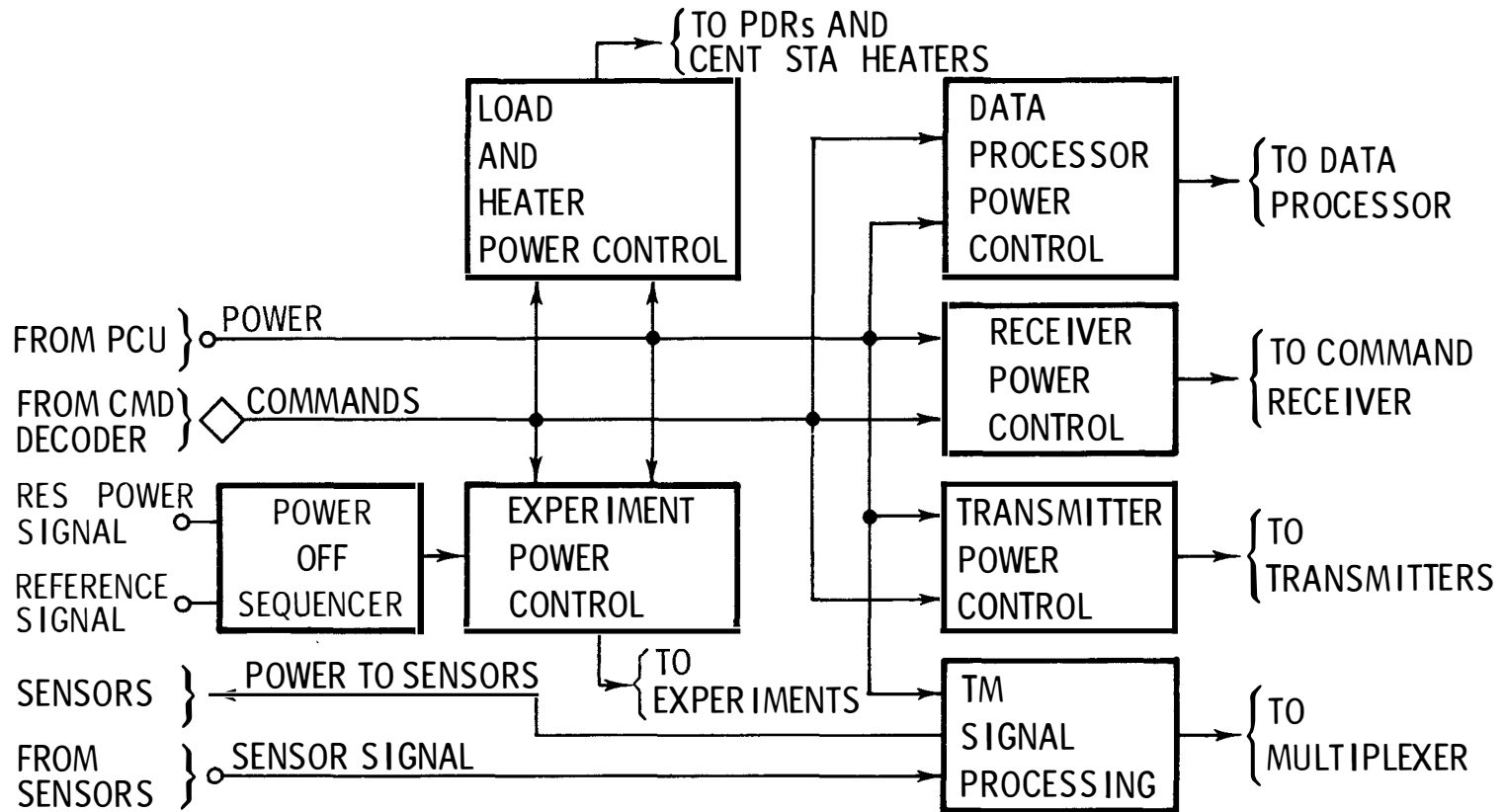

EXPERIMENT POWER CONTROL (1 OF 4)

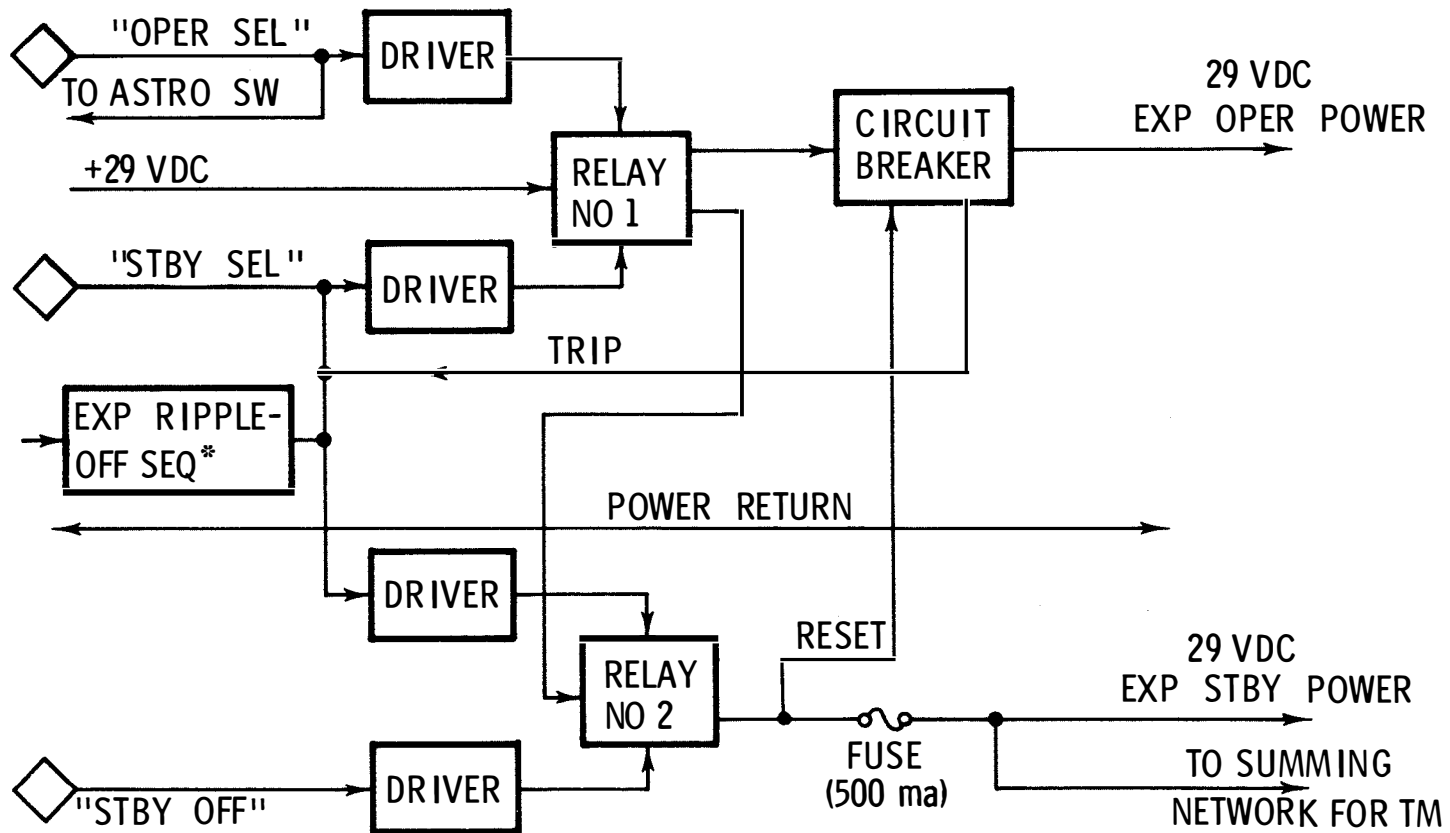

*NOTE: RIPPLE-OFF SEQ USED ON 1, 3 & 4 ONLY

SEPT 68 5178.7.83

EXPERIMENT RIPPLE-OFF SEQUENCE

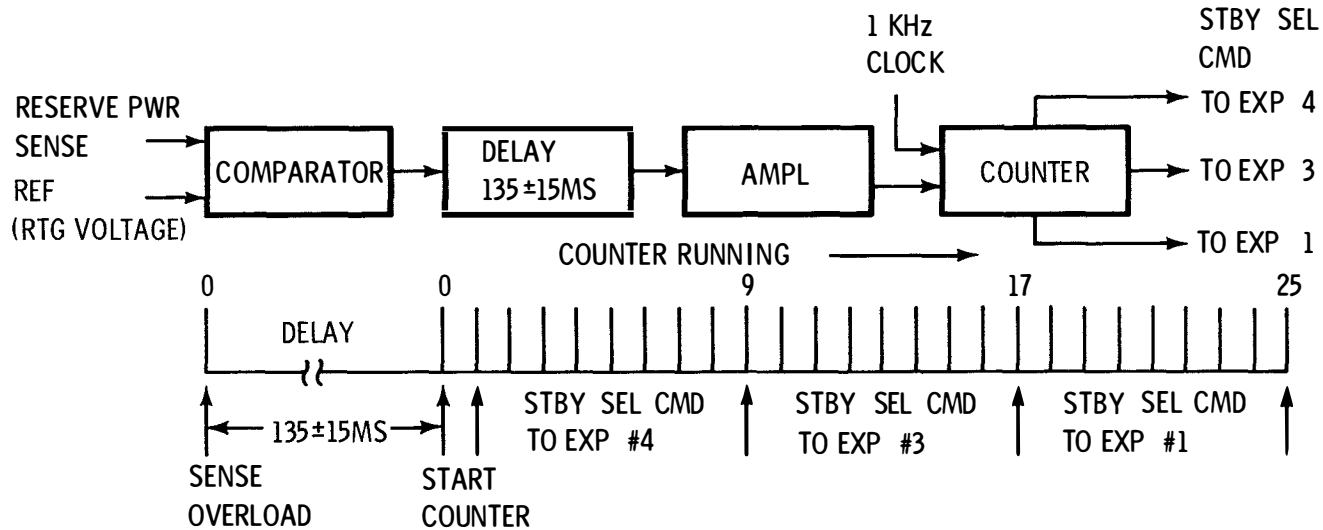

- * IF OVERLOAD CONDITION EXISTS FOR 135 ± 15MS, THEN FROM COUNT 1 TO COUNT 9 A "STBY SEL" CMD IS ISSUED TO EXP #4.
- * AFTER 9MS, IF OVERLOAD STILL EXISTS, A "STBY SEL" CMD IS ISSUED TO EXP #3 FROM COUNT 9 TO COUNT 17.
- * IF OVERLOAD STILL EXISTS, A "STBY SEL" CMD IS ISSUED TO EXP #1 FROM COUNT 17 TO COUNT 25.
- * WHEN OVERLOAD IS CLEARED THE COUNTER IS RESET AND FURTHER EXPERIMENT SWITCHING IS INHIBITED.

EXP PWR MODE TM

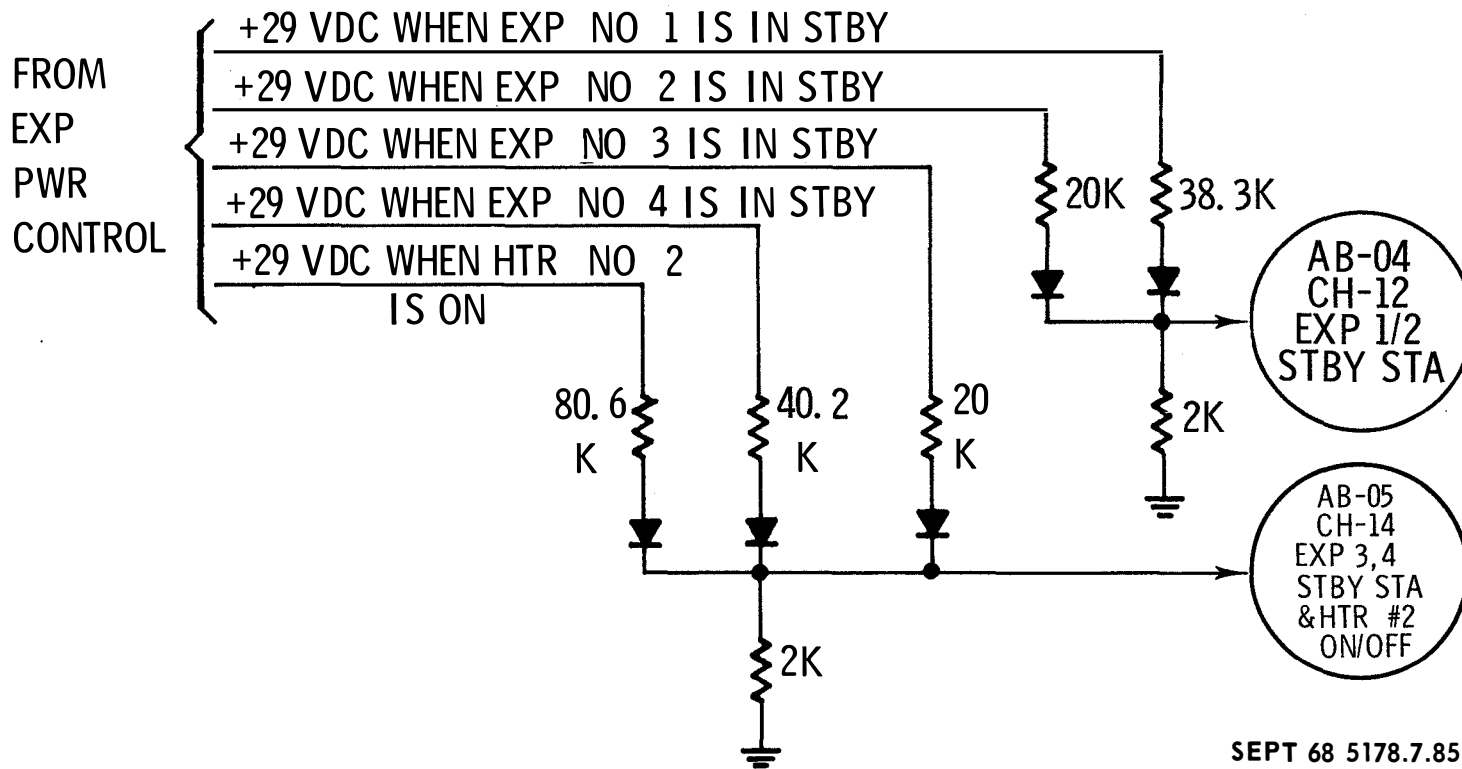

TRANSMITTER POWER CONTROL

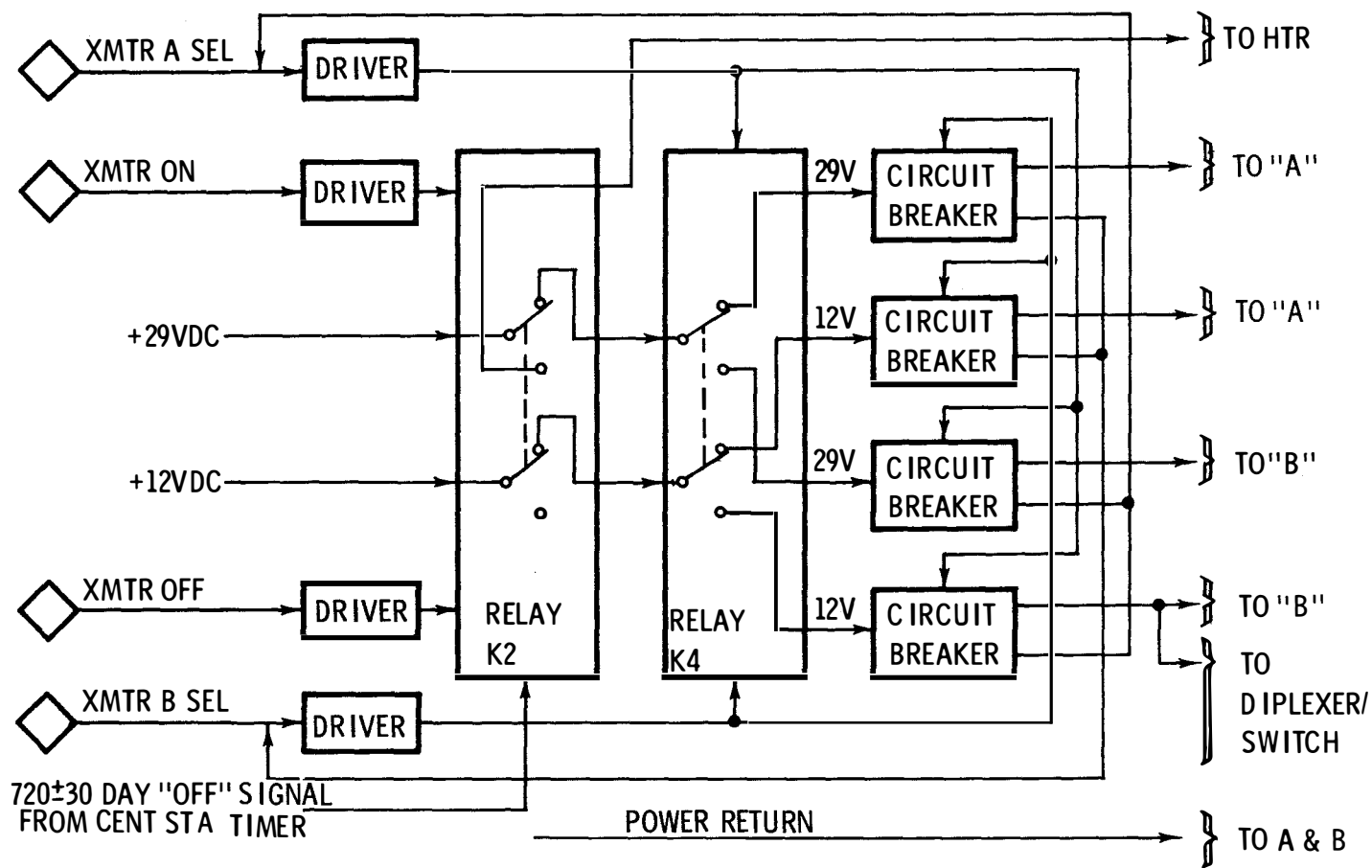

SEPT 68 5178.7.86

DATA PROCESSOR & CMD RCVR PWR CONTROL CKTS

DATA PROCESSOR

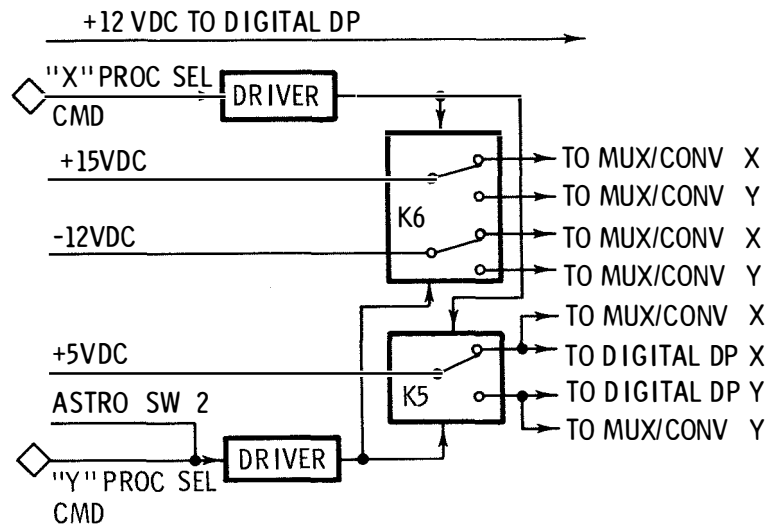

COMMAND RECEIVER

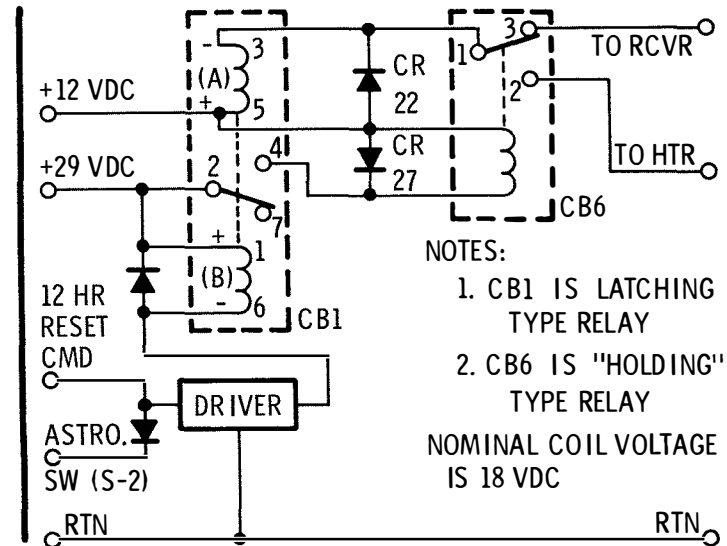

SEPT 68 5178.7.87

SWITCHING FOR POWER DUMP RESISTORS

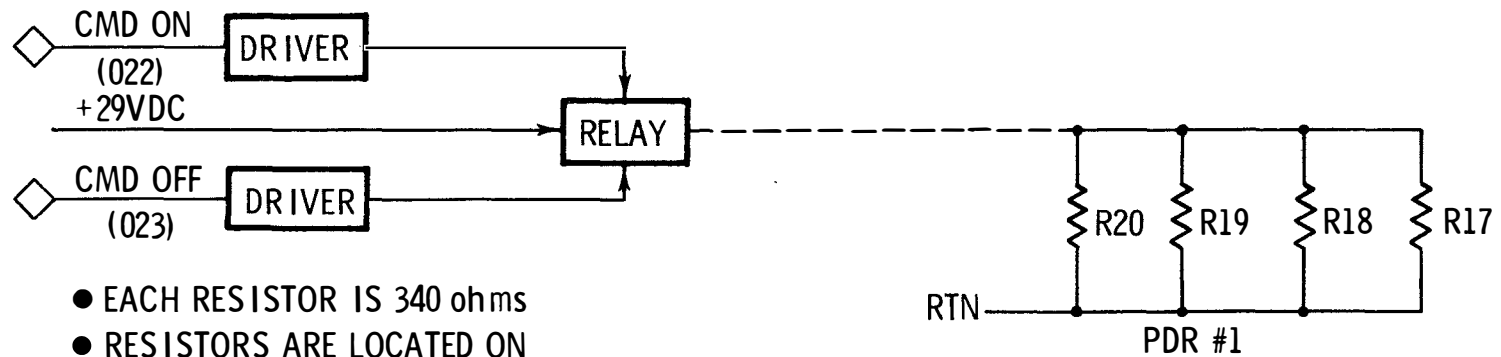
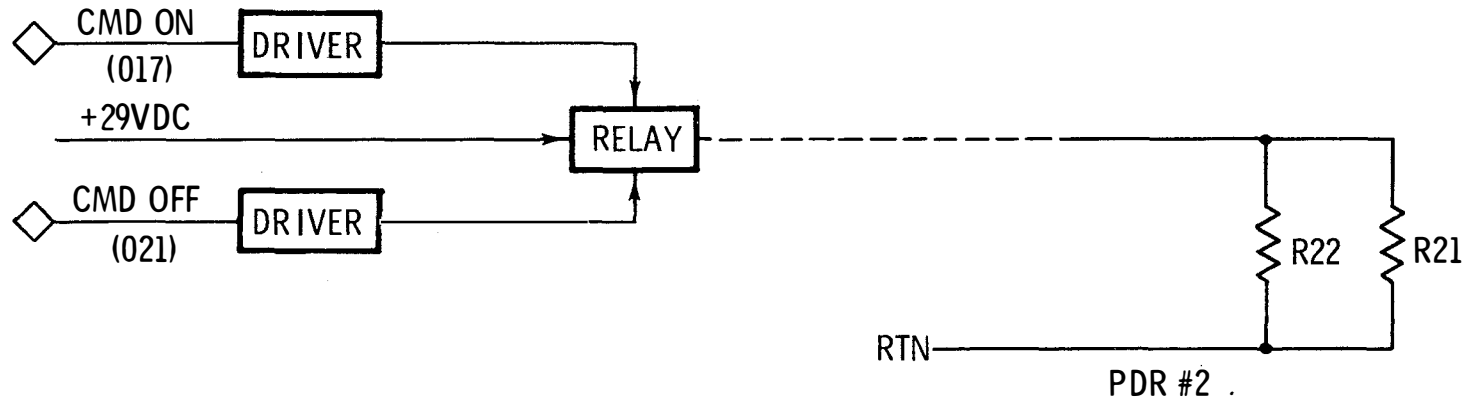

- EACH RESISTOR IS 340 ohms
- RESISTORS ARE LOCATED ON EXTERIOR OF CENTRAL STATION

APR 69 5178.7.88

SWITCHING FOR CENTRAL STA HEATERS

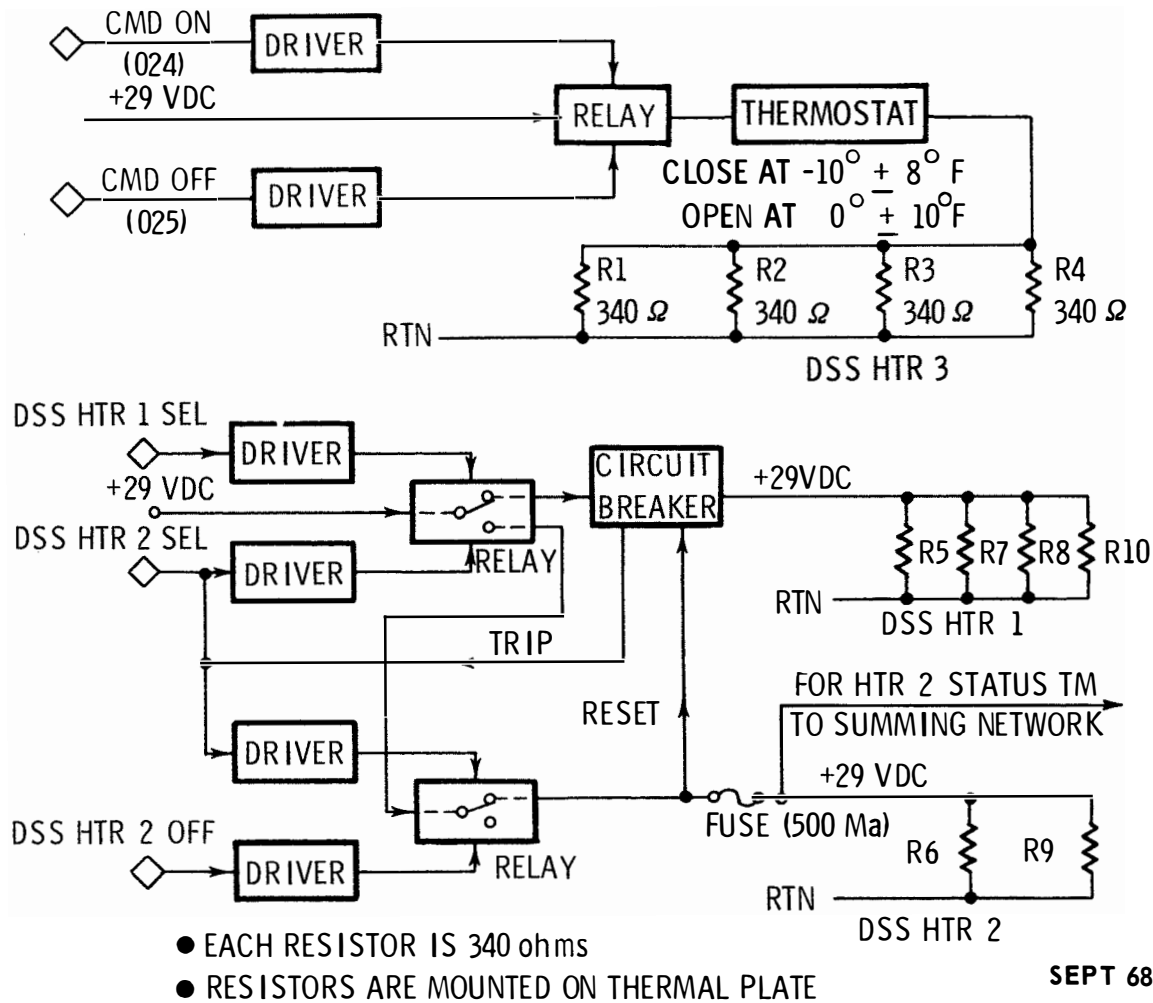

TELEMETRY SIGNAL CONDITIONING

CHANNEL 62 AT-34 POWER DISTRIBUTION, BASE TEMP

CHANNEL 63 AT-35 POWER DISTRIBUTION, INTERNAL TEMP

THE ABOVE SIGNALS ARE OBTAINED FROM THERMISTORS AND RESISTOR DIVIDERS POWERED BY +12VDC. FOR AT-34, THE THERMISTOR IS LOCATED ON THE BASE PLATE AND FOR AT-35 THE THERMISTOR IS LOCATED ON PCB

CHANNEL 06 AR-01 RTG HOT FRAME #1 TEMP

CHANNEL 37 AR-02 RTG HOT FRAME #2 TEMP

CHANNEL 52 AR-03 RTG HOT FRAME #3 TEMP

CHANNEL 07 AR-04 RTG COLD FRAME #1 TEMP

CHANNEL 67 AR-05 RTG COLD FRAME #2 TEMP

CHANNEL 82 AR-06 RTG COLD FRAME #3 TEMP

THE ABOVE TELEMETRY SIGNALS ARE OBTAINED FROM PLATINUM WIRE SENSORS LOCATED IN THE RTG. THESE SENSORS ARE CONNECTED INTO A BRIDGE CIRCUIT LOCATED IN THE PDU. THE BRIDGE OUTPUT IS AMPLIFIED BY A LINEAR DEVICE TO GIVE AN ACCURATE TM VOLTAGE

DEC 67 5178.7.90

PDU TELEMETRY CIRCUITS

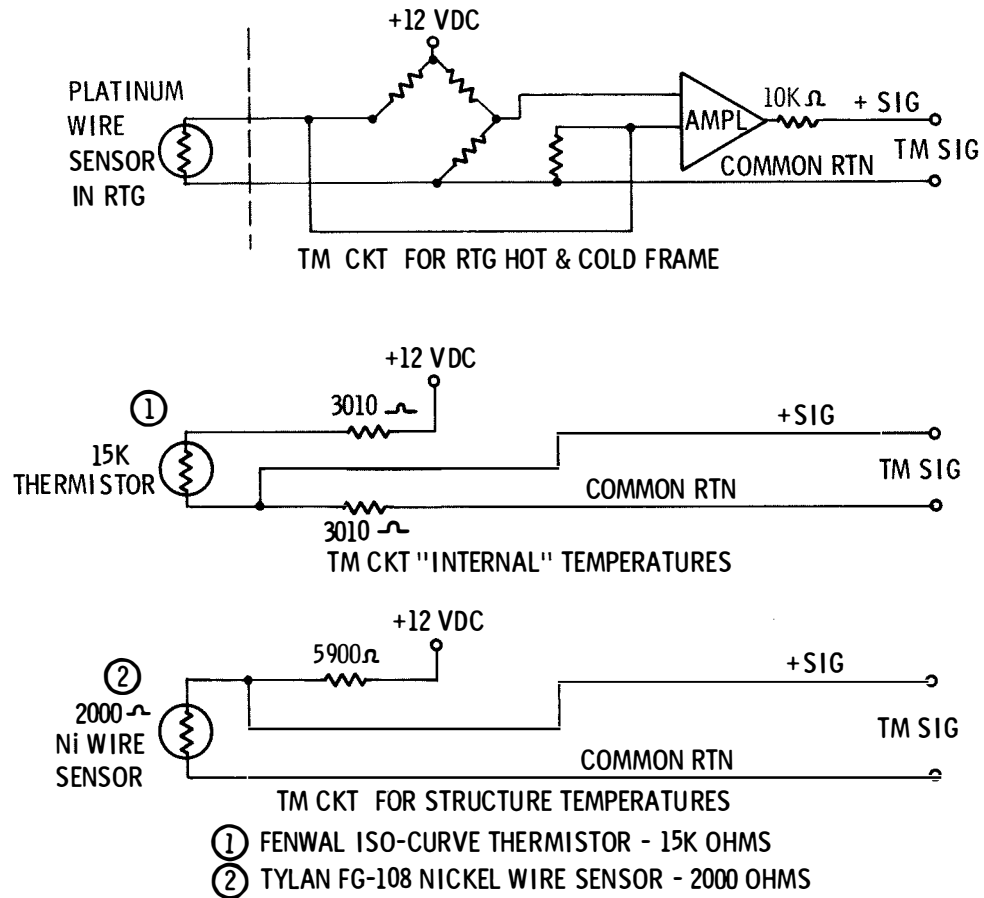

SEPT 68 5178.7.91

TELEMETRY SIGNAL CONDITIONING

THE PDU PROVIDES THE +12 VOLT SUPPLY AND ONE 3010 OHM SERIES RESISTOR FOR EACH OF THE FOLLOWING TM MEASUREMENTS:

CHANNEL 04	AT-03	THERMAL PLATE 1
CHANNEL 28	AT-04	THERMAL PLATE 2
CHANNEL 43	AT-05	THERMAL PLATE 3
CHANNEL 58	AT-06	THERMAL PLATE 4
CHANNEL 71	AT-07	THERMAL PLATE 5
CHANNEL 48	AT-31	COMMAND DECODER BASE TEMP
CHANNEL 49	AT-32	COMMAND DECODER INTERNAL TEMP
CHANNEL 61	AT-33	COMMAND DEMODULATOR, VCO TEMP
CHANNEL 46	AT-29	DIGITAL DP, BASE TEMP
CHANNEL 47	AT-30	DIGITAL DP, INTERNAL TEMP

TELEMETRY SIGNAL CONDITIONING

THE PDU PROVIDES +12 VOLTS AND ONE 5900 OHM RESISTOR, IN SERIES WITH THE EXTERNALLY LOCATED 2000 OHM NICKEL WIRE SENSOR, FOR EACH OF THE FOLLOWING TM MEASUREMENTS:

CHANNEL 27	AT-01	SUNSHIELD TEMP 1
CHANNEL 42	AT-02	SUNSHIELD TEMP 2
CHANNEL 59	AT-08	LEFT SIDE STRUCTURE TEMP W1
CHANNEL 87	AT-09	RIGHT SIDE STRUCTURE TEMP W2
CHANNEL 15	AT-10	BOTTOM STRUCTURE TEMP B1
CHANNEL 88	AT-11	BACK STRUCTURE TEMP W3
CHANNEL 60	AT-12	INSULATION INNER TEMP
CHANNEL 72	AT-13	INSULATION OUTER TEMP

MISCELLANEOUS ITEMS

- CENTRAL STATION TIMER
- ASTRONAUT BACK-UP SWITCHES
- WIRE HARNESS

CENTRAL STATION TIMER

- THE CST IS AN ACCUTRON MECHANISM OBTAINED FROM THE BULOVA WATCH CO.
- A TUNING FORK IS USED TO ACCURATELY CONTROL SWITCH CLOSURE TIME
- SIZE: 1.32 x 1.32 x 2.63 INCHES
- WEIGHT: 0.265 POUNDS
- POWER IS PROVIDED BY A SEPARATE BATTERY
- TWO MODES OF OPERATION ARE PROVIDED-
 - "STOP MODE" - POWER IS APPLIED AND FORK IS OSCILLATING AT LOW LEVEL - ROTARY MOTION IS NOT PRODUCED. MAXIMUM CURRENT IS 7 MICROAMPERES. THIS MODE IS USED FROM FINAL TEST UNTIL DEPLOYMENT ON THE LUNAR SURFACE
 - "START MODE" - ADDITIONAL POWER IS APPLIED FOR INCREASED AMPLITUDE OF FORK OSCILLATION. ROTARY MOTION IS PRODUCED TO DRIVE THE SWITCH MECHANISM. MAXIMUM CURRENT IS 12 MICROAMPERES

SEPT 68 5178.7.95

TIMER AND BATTERY

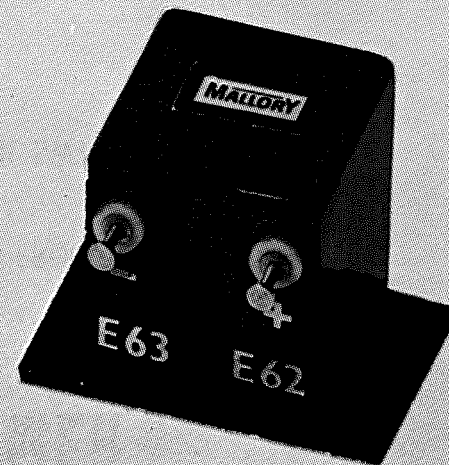
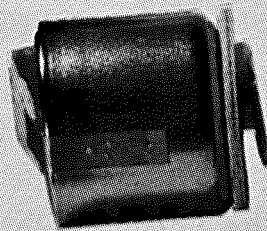
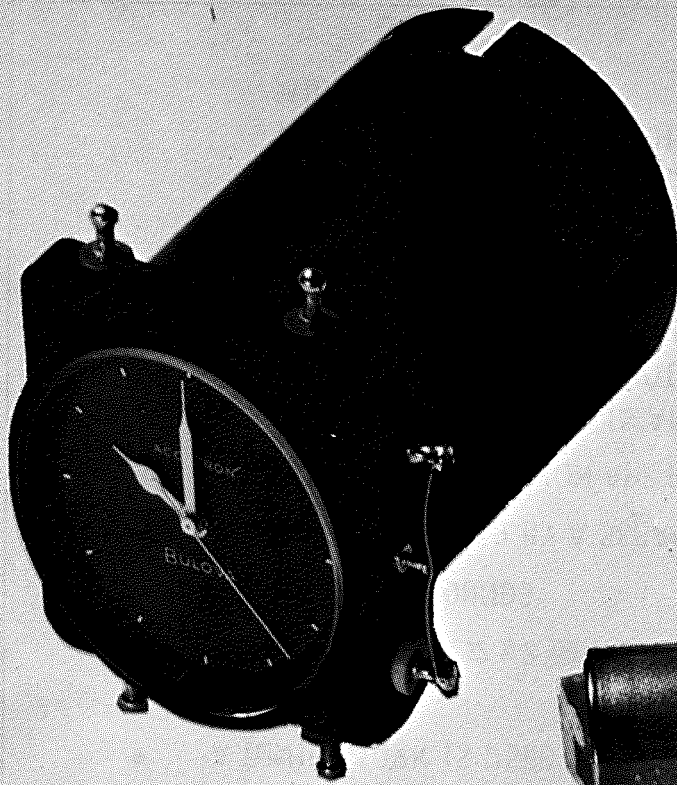

DEC 67 5178.7.96

CENTRAL STA TIMER MECHANISM

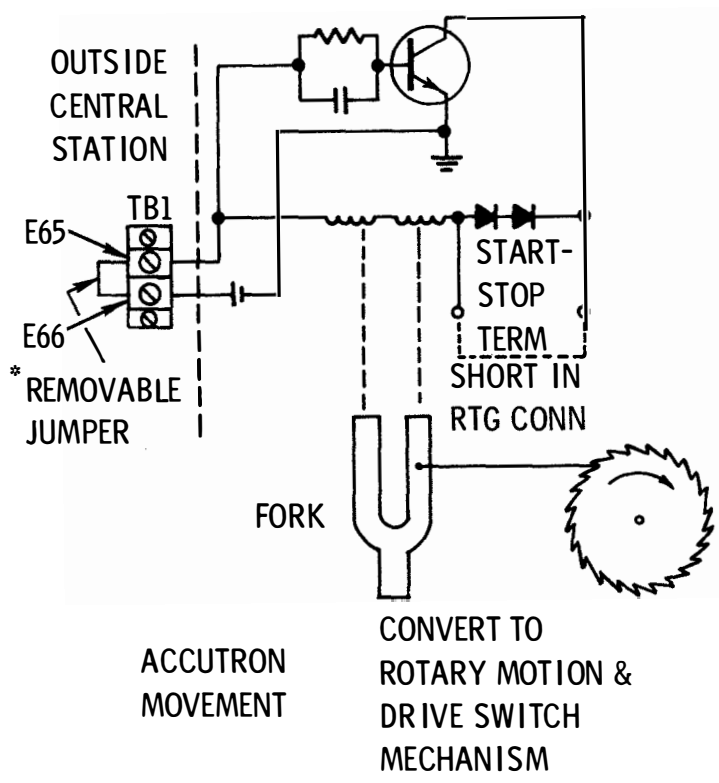

* JUMPER IS REMOVED AND 360 Hz SIGNAL APPLIED TO START FORK.

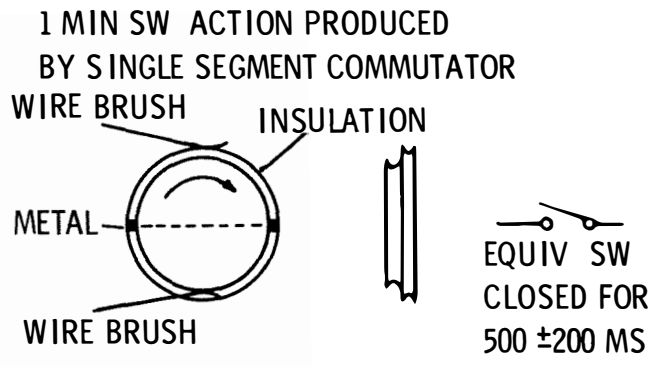

12 HR SWITCH IS PRODUCED SNAP ACTION MECHANISM



720 ± 30 DAY SWITCH

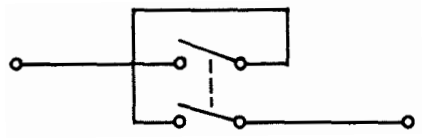

CENT STA TIMER BATTERY

- CONSISTS OF A P.R. MALLORY ZINC-MERCURIC-OXIDE, TYPE RMCC1W CELL, IN A SPECIAL PACKAGE FOR ALSEP. BASIC CELL IS CALLED "PACER"
- INITIAL TERMINAL VOLTAGE IS 1.5 VOLTS MAXIMUM
- MINIMUM CELL CAPACITY IS 750 MILLIAMPERE HOURS
- CELL CAPACITY IS DERATED TO 375 MILLIAMPERE HOURS FOR ALSEP
- CELL CAPACITY IS GUARANTEED AFTER STORAGE (OPEN CIRCUIT) FOR UP TO 2 YEARS
- OPERATING TEMPERATURE IS -27 to +162⁰F

ASTRONAUT SWITCHES

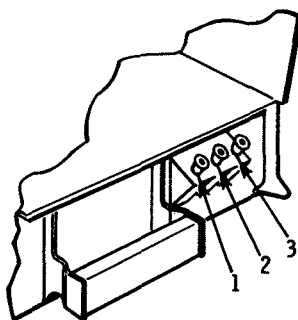
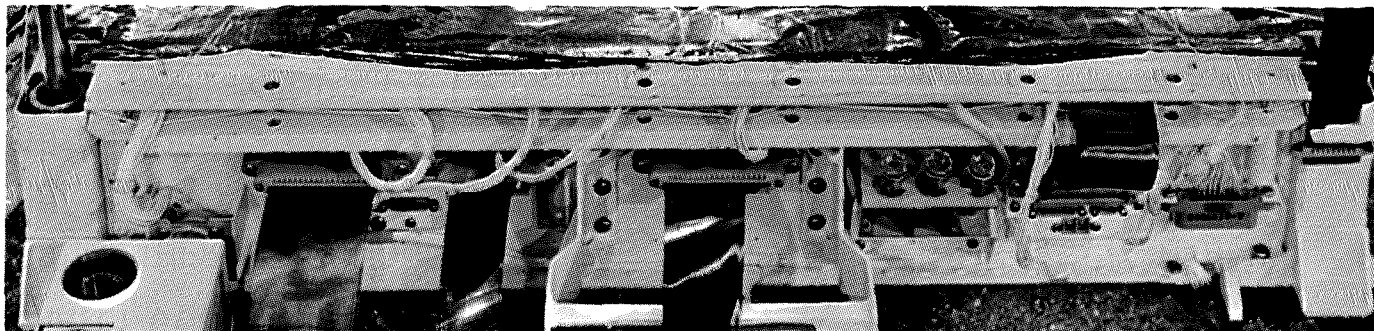

- SWITCHES INTERFACE WITH UHT
- ALL SWITCHES ROT CW
- VISUAL INDICATORS SHOW SWITCH POS

SWITCH NUMBER	QTY/TYPER/ROT	FUNCTION
1	1/SPST/180° NON-MOMENTARY	DISABLES THE HOLD-OFF CIRCUIT. MUST BE OPERATED BY THE ASTRONAUT
2	1/SPST/180° MOMENTARY	(A) TURN XMTR B ON (B) TURN DATA PROCESSOR Y ON (C) RESET RCVR
3	4/SPST/270° MOMENTARY	MECHANICALLY GANGED & OPERATED SEQUENTIALLY TO ACTIVATE EXPR OPER SEL POWER SWITCHES (IN 1, 2, 4, 3 ORDER) AT ≈0.1 SEC INTERVALS

ALSEP 4 INCLUDES THE ASE; HAS 2 ADDITIONAL:	
BACKUP	4 { (A) ACTIVATE ASE OPER SEL POWER SWITCH (NOT INC ON SW #3) (B) SWITCH DATA PROCESSOR TO ASE HBR ON
OPERATIONAL	5 { (A) ACTIVATE ASE STBY SEL POWER SWITCH (B) SWITCH DATA PROCESSOR TO ASE HBR OFF (RETURN TO NORM BIT RT) (C) ACTIVATE SWITCH TO INTERRUPT ASE 29 V OPER PWR LINE; SAFETY FEATURE REDUNDANT WITH (A)

NOV 68 5178.7.99

WIRE HARNESS

- ALL COMPONENTS ARE INTERCONNECTED WITH A PRE-FORMED WIRE HARNESS WHICH PROVIDES THE PROPER MATING PLUGS
- WITHIN THE THERMALLY CONTROLLED AREA, AWG# 24 SINGLE CONDUCTOR, STRANDED, COPPER WIRE IS USED
- TWO PRINTED CIRCUIT TERMINAL BOARDS ARE USED TO PERMIT TRANSITION FROM COPPER TO MANGANIN FOR WIRES WHICH MUST GO OUTSIDE THE THERMALLY CONTROLLED AREA
- TO REDUCE THERMAL CONDUCTION, MANGANIN WIRE, WHICH HAS A THERMAL CONDUCTIVITY ABOUT 1/17 THAT OF COPPER, IS USED BETWEEN THE PC TERMINAL BOARDS AND EXTERNAL INTERFACES (CONNECTORS). BECAUSE OF THE HIGH CURRENT, + AND - WIRES TO THE RTG CONNECTOR ARE COPPER
- CONNECTORS USED ARE MADE BY HUGHES, SCHJELDAHL, DEUSTCH AND MICRODOT

JAN 69 5178.7.100

HARNESS TO EXTERNAL CONNECTORS

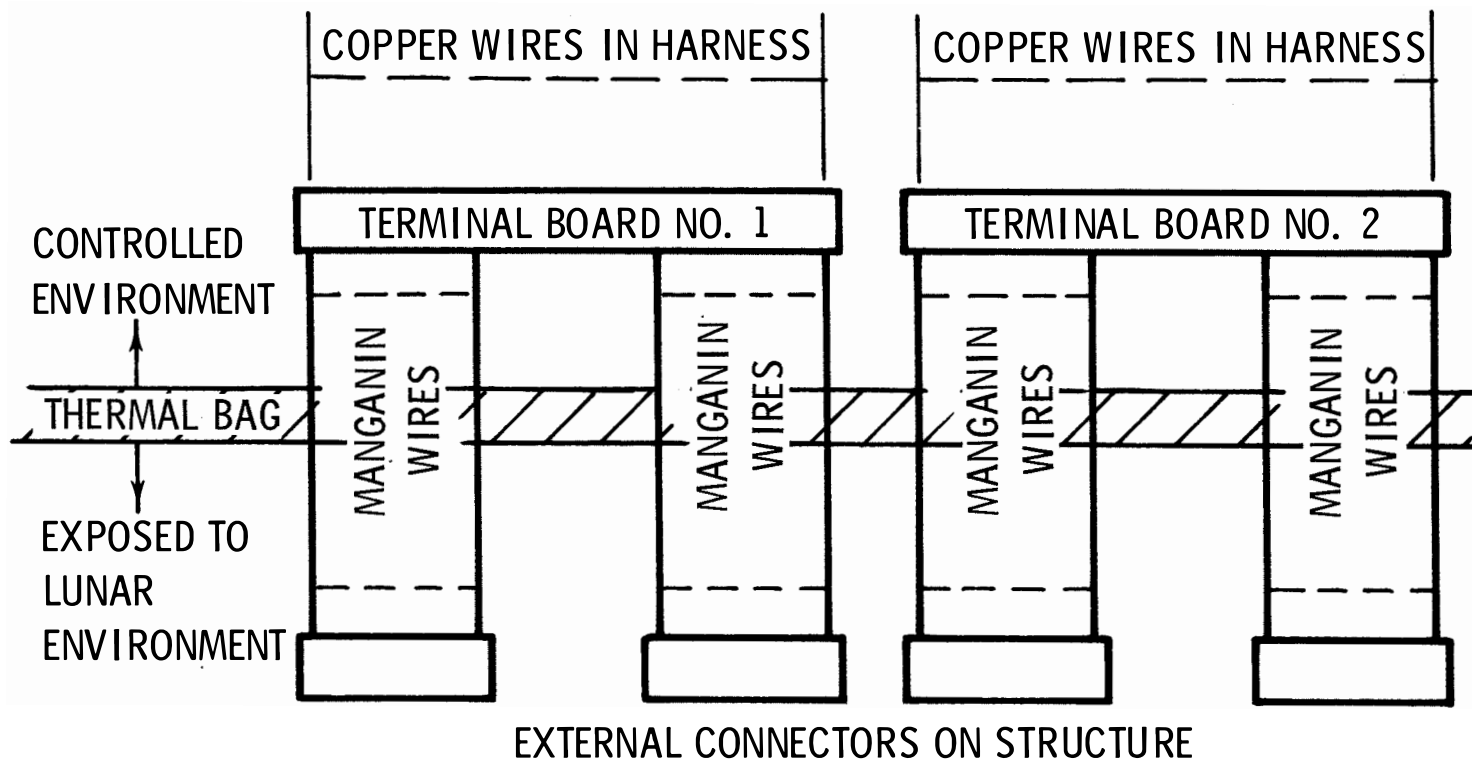

DEC 67 5178.7.101

PASSIVE SEISMIC EXPERIMENT

- COMPONENTS & FUNCTION
- DEPLOYMENT
- COMMANDS & DATA

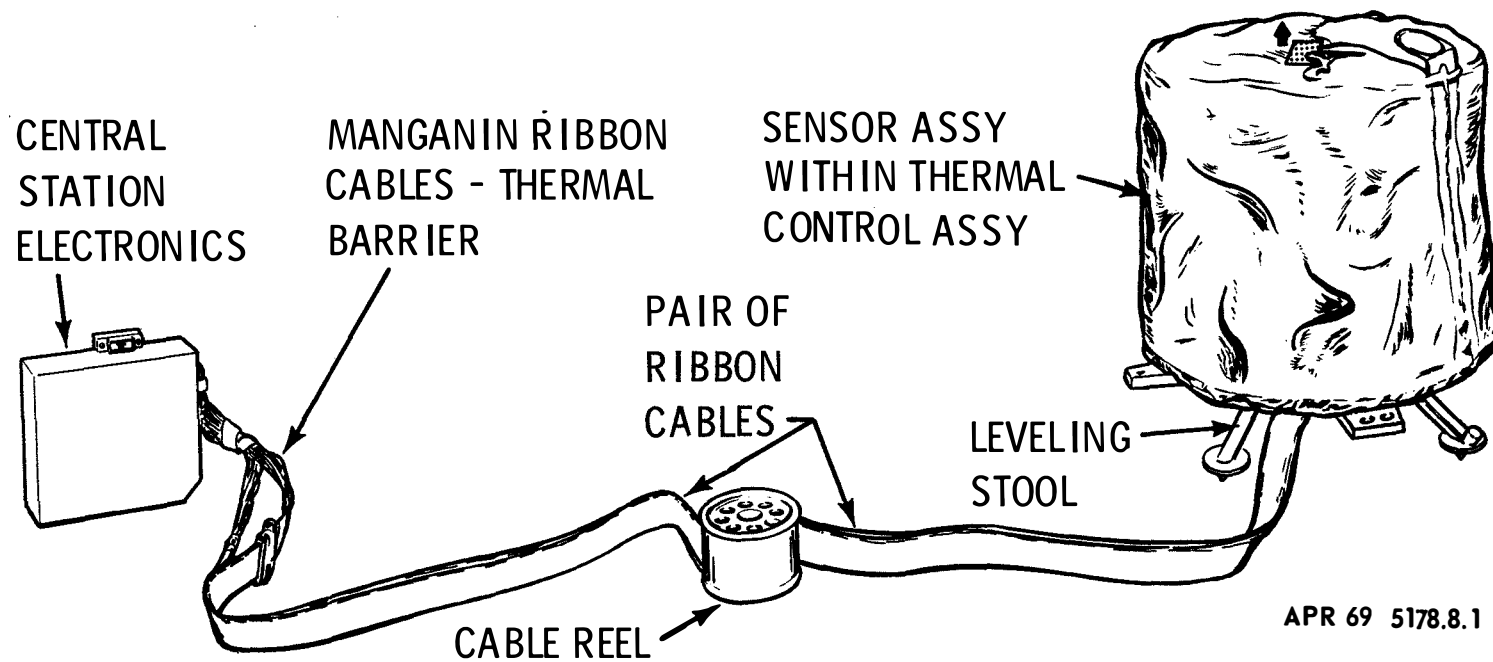

INSTRUMENT DETAILS

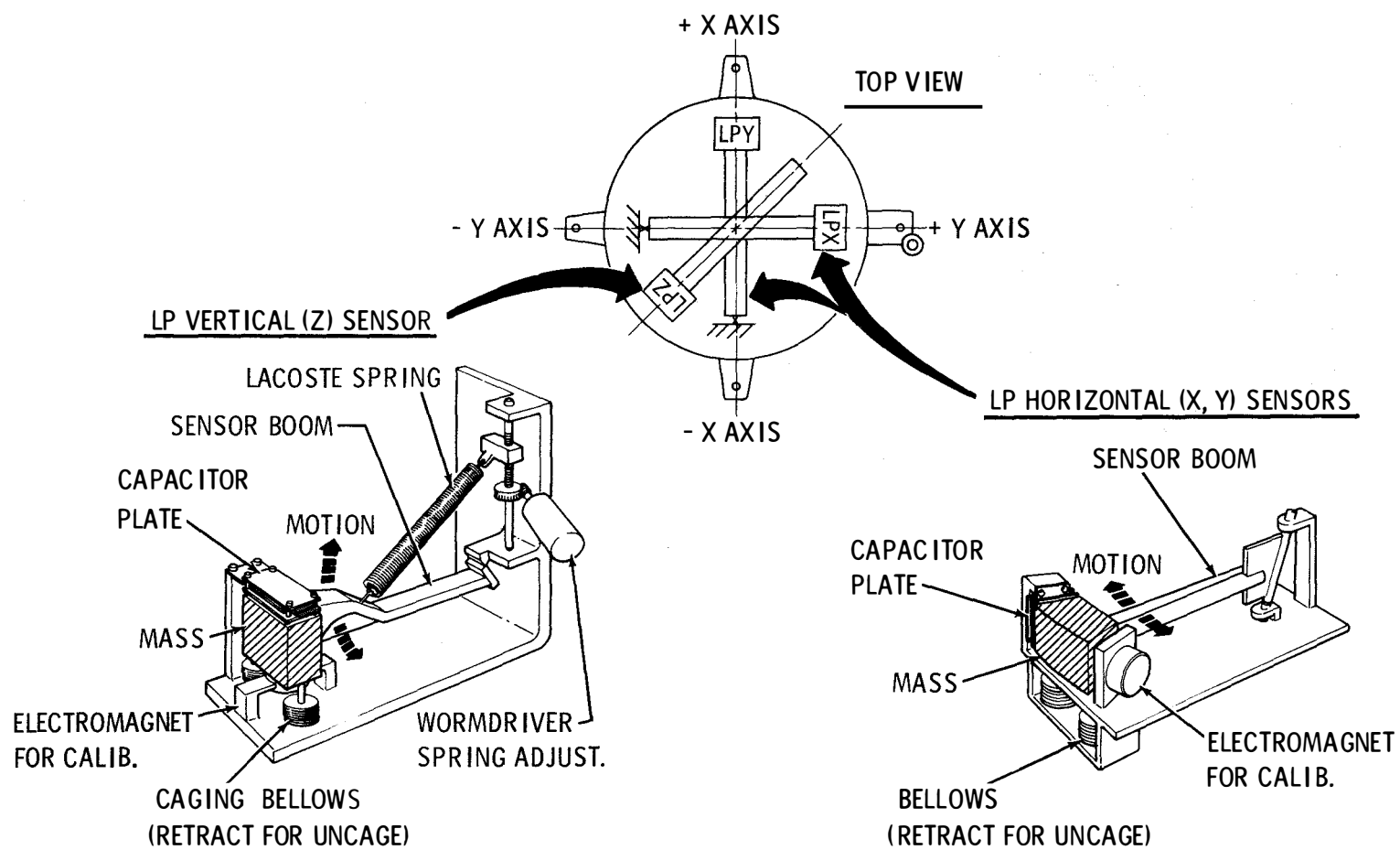

APR 69 5178.8.2

PSE FUNCTIONAL BLOCK DIAGRAM

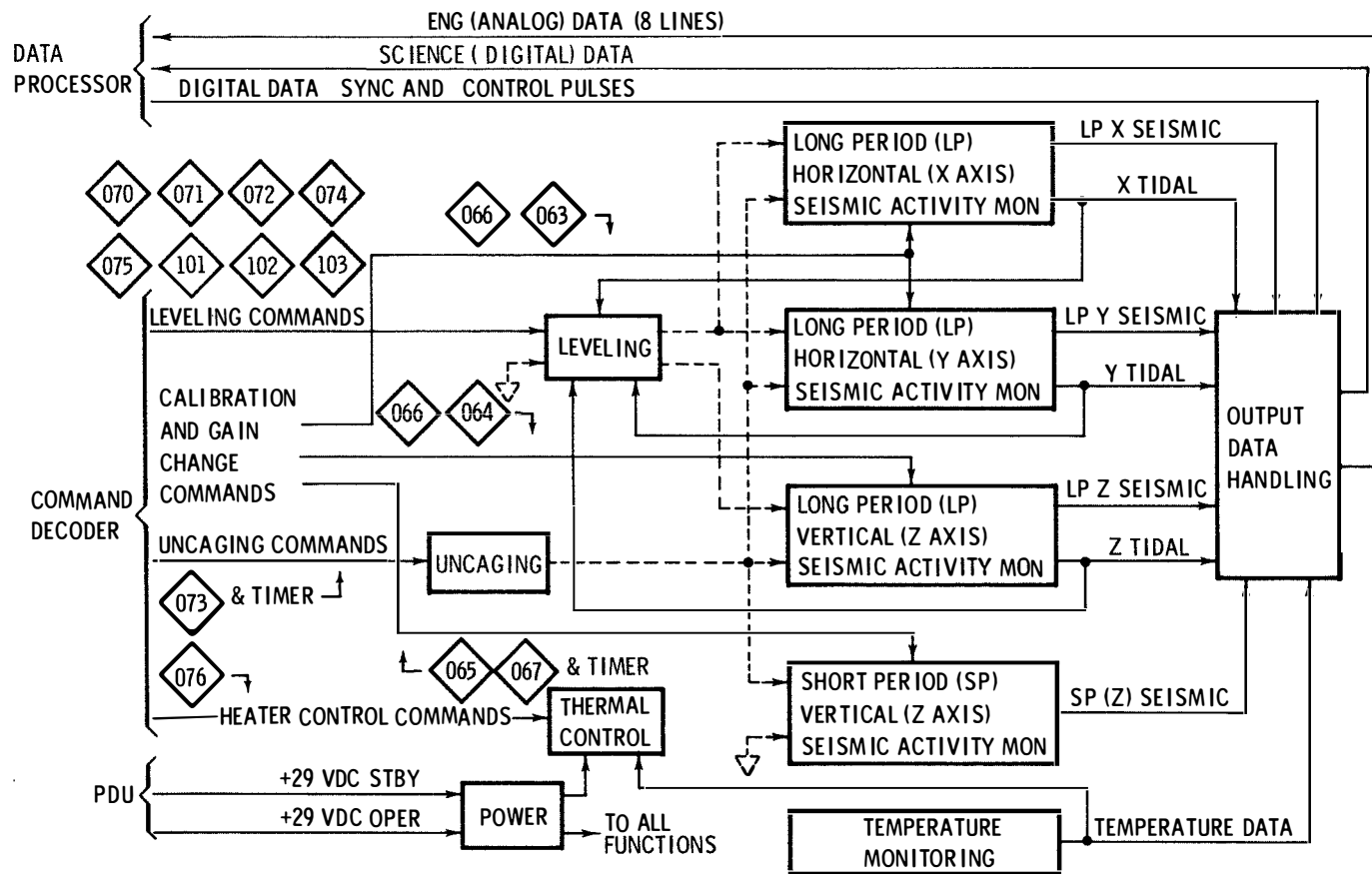

LONG PERIOD (LP) SEISMIC FUNCTION

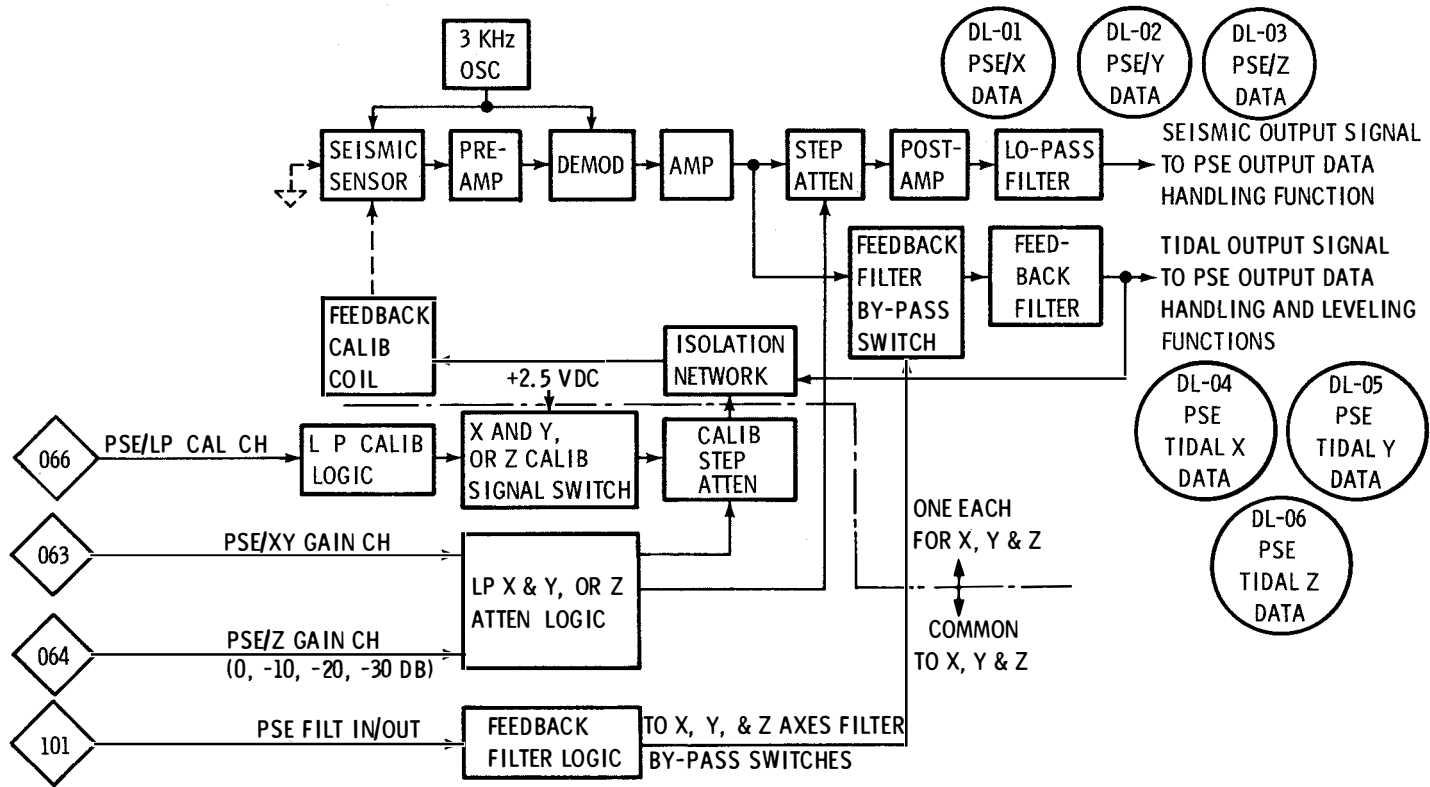

SHORT PERIOD (SP) SEISMIC FUNCTION

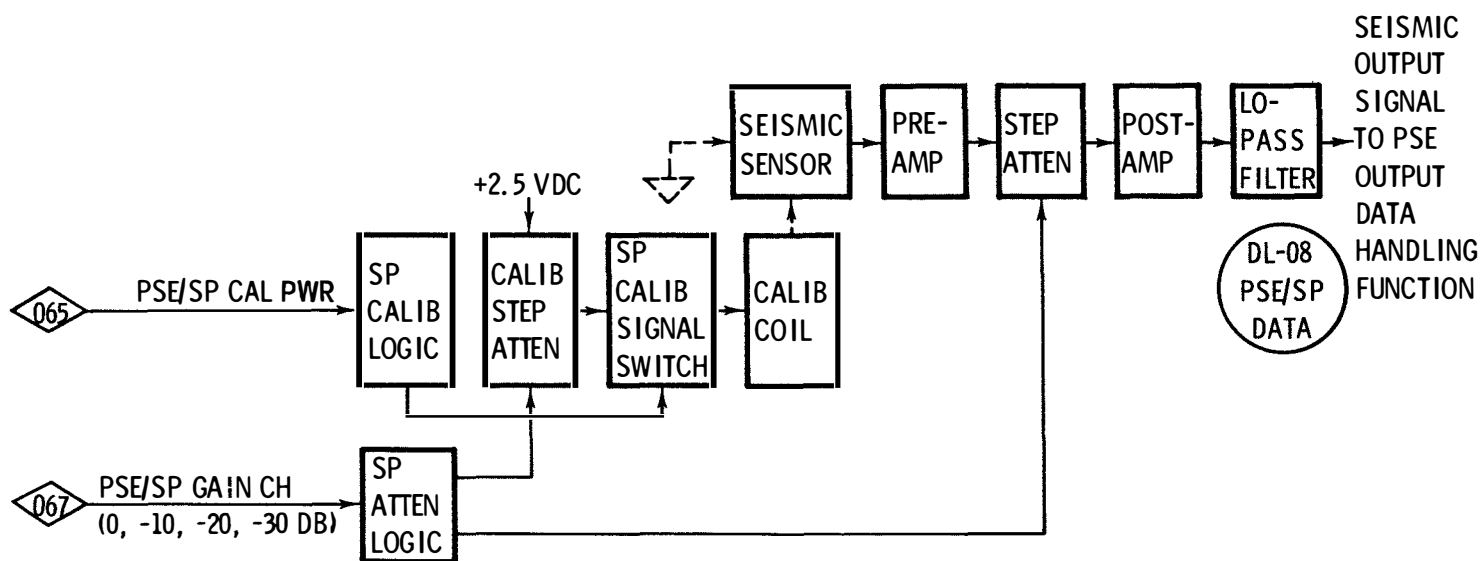

DATA HANDLING FUNCTION

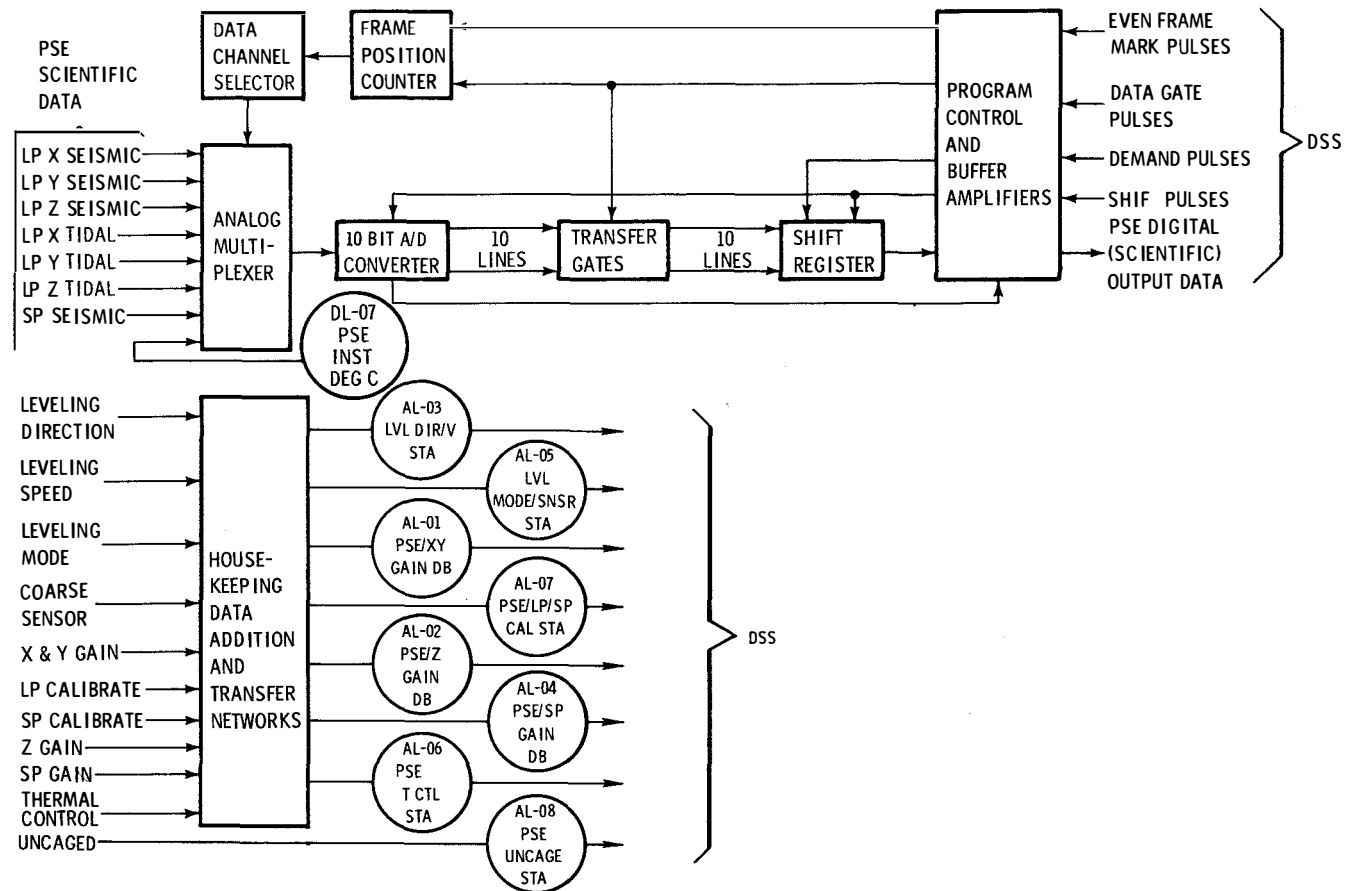

UNCAGING AND LEVELING FUNCTION

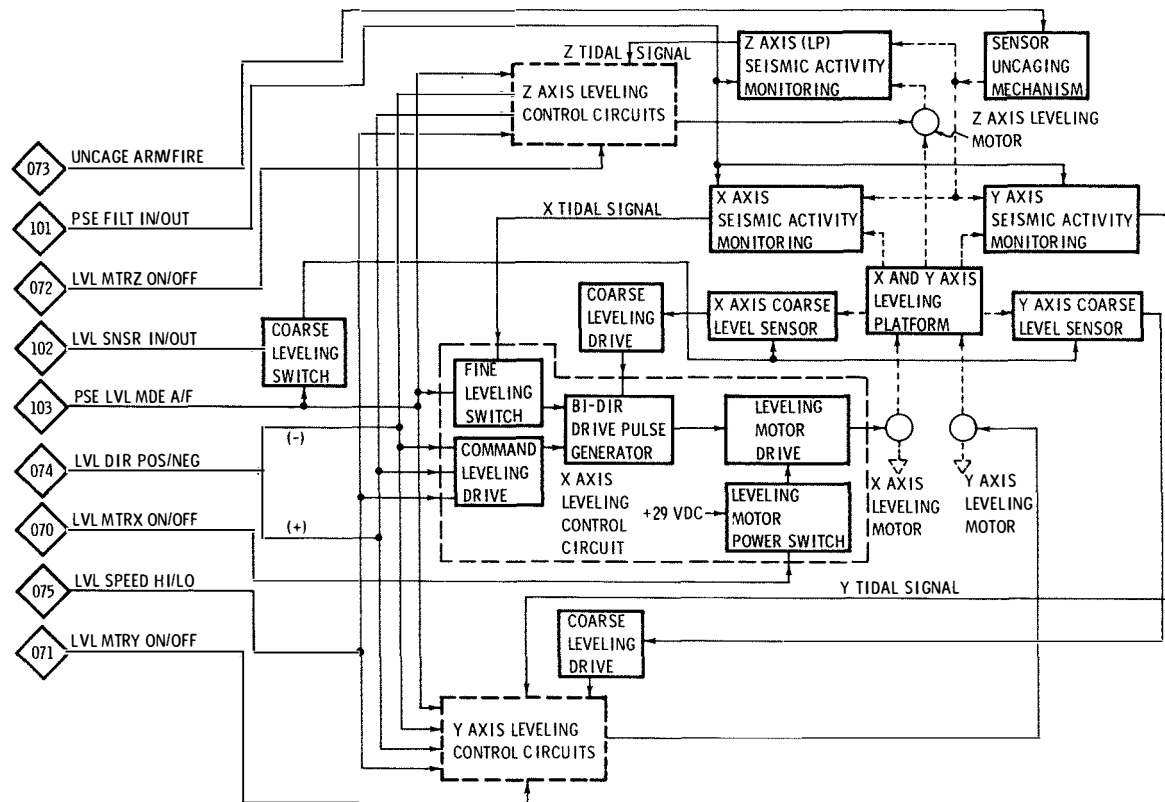

SEPT 68 5178.8.7

PSE THERMAL CONTROL

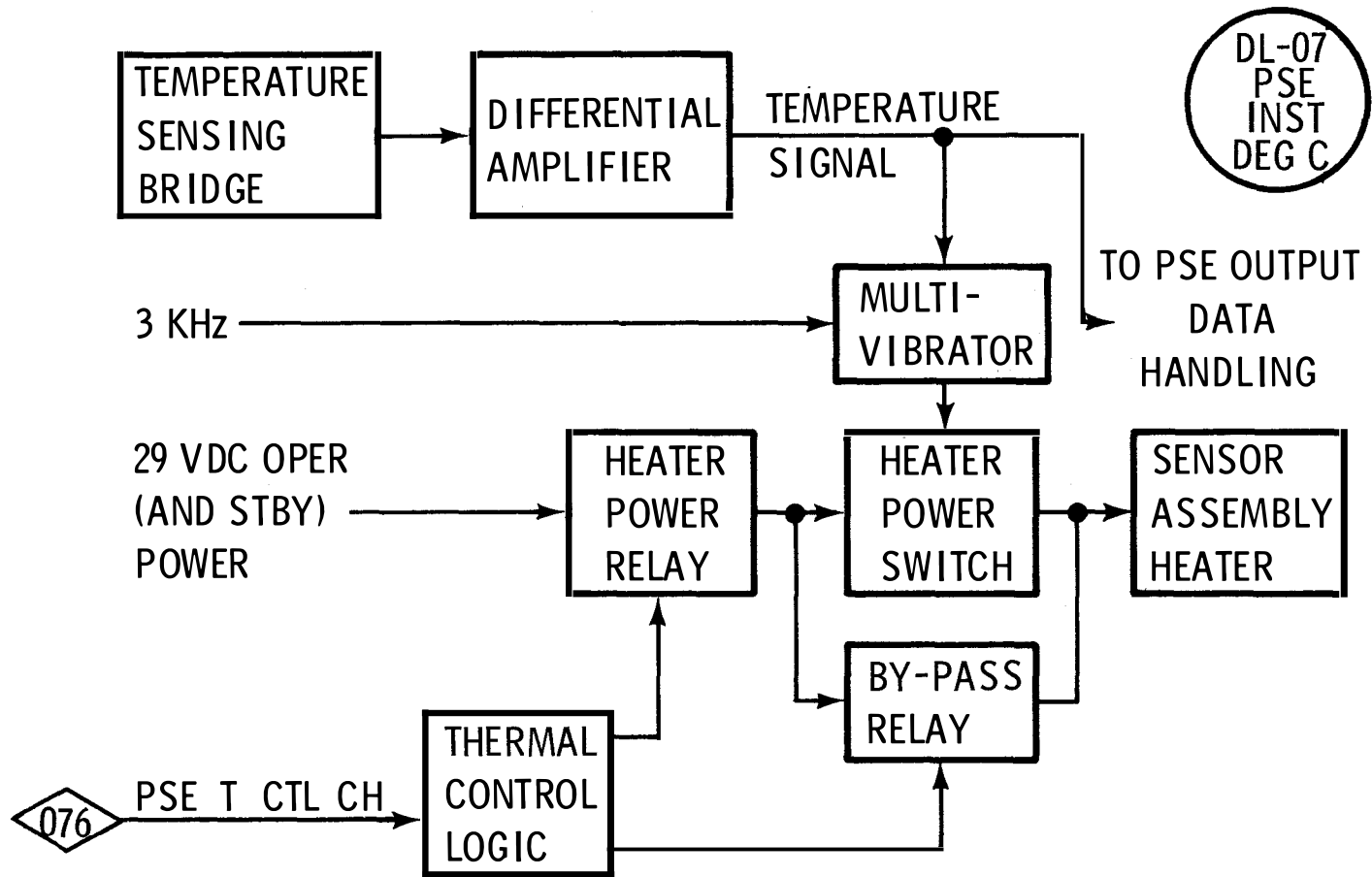

PSE TIMING

TIMING PULSES PROVIDED BY DSS FOR SYNCHRONIZATION AND DATA CONTROL

<u>PULSE</u>	<u>SUBFUNCTION</u>
EVEN FRAME MARK	PROGRAM CONTROL, FRAME POSITION COUNTER, DATA CHANNEL SELECTOR
DATA DEMAND	ALLOWS DATA SHIFT OUT TO DSS
DATA GATE	INDICATES INDIVIDUAL WORDS WITHIN A DATA DEMAND PULSE OF MULTIPLE WORD LENGTH
SHIFT PULSE	TIMING FOR DATA SHIFT-OUT

NOTE: TIMING DOES NOT AFFECT THE PSE POWER PROFILE.

PSE POWER PROFILE

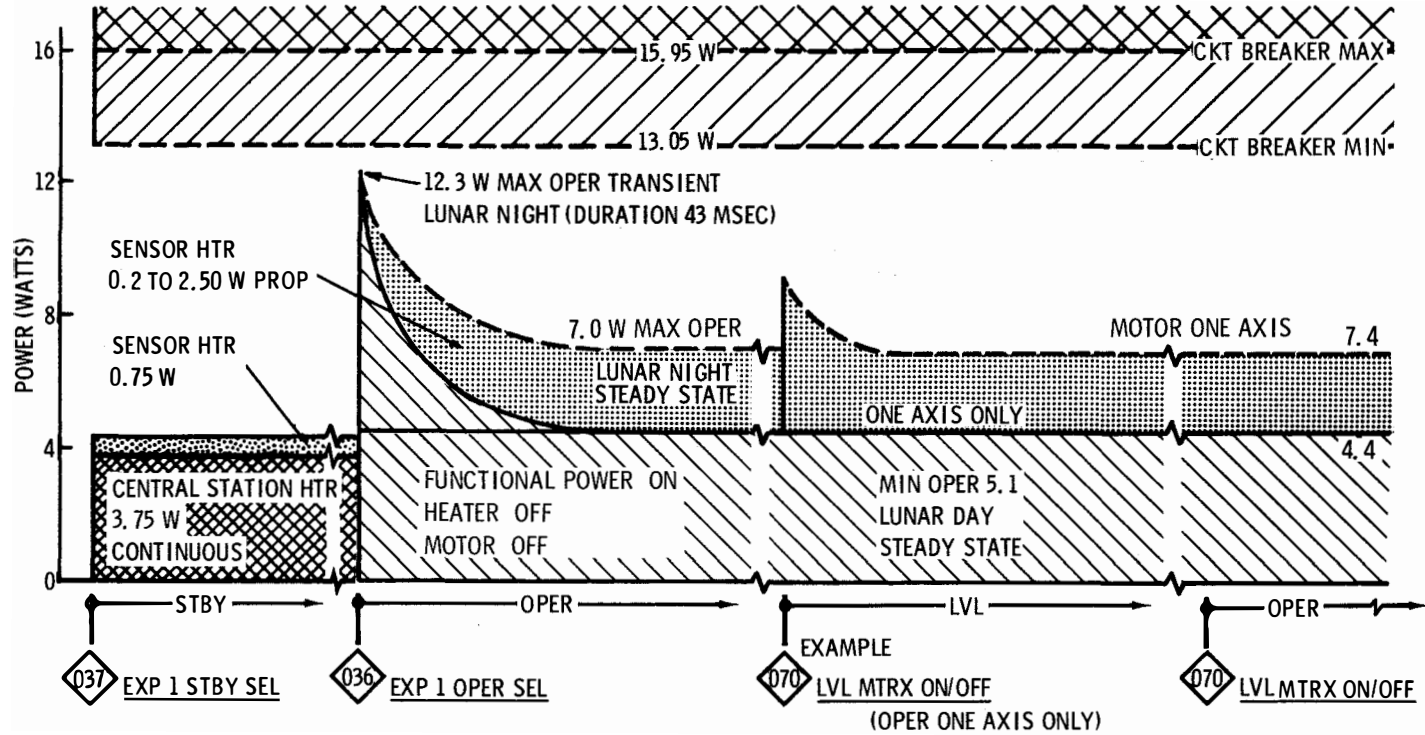

PSE TIE-DOWN

RELEASE 4 FASTENERS

INSERT UHT

LIFT EXPERIMENT

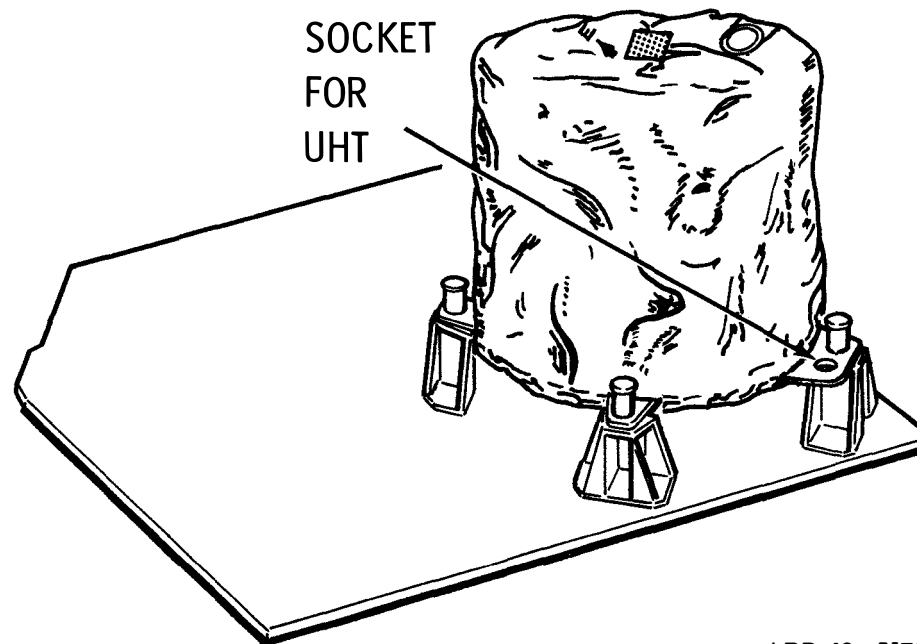

APR 69 5178.8.11

PSE EMPLACEMENT CRITERIA

PARAMETER	REQUIREMENT	PRIORITY	INDICATOR	COMMENTS
DISTANCE FROM SUBPACKAGE 1	9 ±1 FT	1	10 FT CABLE	15 FT SEPARATION REQUIREMENT FROM RTG FOR THERMAL REASONS
DIRECTION FROM SUBPACKAGE 1	DUE E OR W*	1	EYEBALL	OUT OF FIELD OF VIEW OF CENTRAL STATION RADIATOR
SITE SELECTION	'QUIET' LOCATION	1	EYEBALL	FREE FROM LOOSE RUBBLE
LEVEL, WRT INDICATOR	±5° OF HORIZONTAL	1	BALL LEVEL	INTERACTS WITH ALIGNMENT; INSTRUMENT FINE-LEVELS INTERNALLY
ROUGH ALIGN	±20° OF E-W	2	ARROW**	BEFORE OPENING SHROUD
READOUT OF ALIGNMENT WRT SHADOW	±5° OF E-W	1	FULL ROSE	AFTER OPENING SHROUD
EXPERIMENT INTERRELATION	*NO LESS THAN 10 FT FROM OTHER SUBSYSTEMS TO MINIMIZE PICKUP OF STRAY VIBRATIONS.			
SPECIAL REQUIREMENTS	**ARROW NOMINALLY POINTS EAST ALTHOUGH SCIENTIFIC OUTPUT DEPENDS ONLY ON KNOWING FINAL ALIGNMENT. FINAL READING IS ACCOMPLISHED WITH ASS ISTANCE OF AZIMUTH GNOMEN MOUNTED ON TOP OF THERMAL SHROUD.			

APR 69 5178.8.12

PSE ALIGNMENT MARKINGS

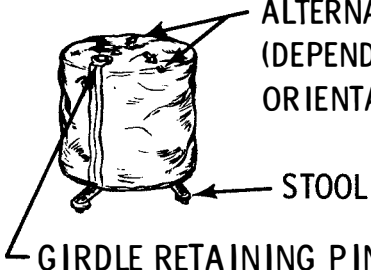
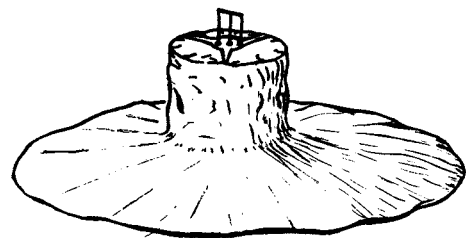
PHASE	CONFIGURATION	TASK	MARKING
INITIAL	CYLINDRICAL SENSOR ASSY INSIDE THERMAL CASE, ENCLOSED IN THERMAL SHROUD WITH GIRDLE OVER SHROUD	ROUGH ALIGN VIA MARKING ON TOP OF GIRDLE (ARROW EAST)	 <p>ALTERNATE LOCATIONS (DEPENDING ON SENSOR ORIENTATION INSIDE)</p> <p>STOOL</p> <p>GIRDLE RETAINING PIN</p>
FINAL	SHROUD OPENED & ASSY LEVELED	READOUT VIA SHADOWS WRT COMPASS MARKINGS ON TOP	

PSE OPERATE MODES

CAGED: PROTECTS EQUIPMENT
PRECEDES OTHER MODES
CANNOT BE RECAGED AFTER UNCAGE

NORM (UNCAGED): DIGITAL SCIENCE DATA (INCLUDING ONE TEMP
MEAS FOR DATA INTERPRETATION)
ANALOG ENG DATA

LEVEL: REQUIRED FOR VALID DATA
MAY BE REPEATED
TWO METHODS • AUTO-SERVO LEVELED
• FORCED-COMMANDED STEPS FROM OBSERVED
DATA
NOTE: Z-AXIS 'LEVELING' IS ADJUSTMENT OF LACOSTE SPRING

CALIB: THREE DISTINCT FUNCTIONS

- CALIB SP
- CALIB LP X & Y (HORIZ)
- CALIB LPZ

PSE COMMAND PHILOSOPHY

- COMMANDS ARE INTERRELATED
- LEVELING MODE IS AN EXAMPLE
- ALL THESE CMDs ARE BI-STATE CMDs

ORDER OPTIONAL
BUT MUST BE
SET WITH
070, 071, &
072, OFF

SEND
LAST BUT
ONLY ONE
ON AT A TIME.
X, Y TO PRECEDE Z

OCTAL CMD	CMD	LEVELING MODE			
		AUTO		FORCED	
		COARSE	FINE	FAST	SLOW
103	LVL MDE A/F	A		F	
101	FILT IN/OUT	OUT	IN	OUT	
102	LVL SNSR IN/OUT	IN	OUT	IN	OUT
074	LVL DIR POS/NEG	--		POS/NEG	
075	LVL SPEED HI/LO	--		HI	LO
070	LVL MTRX ON/OFF	X		X	
071	LVL MTRY ON/OFF	Y		Y	
072	LVL MTRZ ON/OFF	OR Z		OR Z	

AS REQD

* INDIVIDUAL
MOTORS MUST BE
CMD OFF AFTER
LEVELING AS EACH
CONTINUES TO
DRAW POWER

* IN FORCED MODE THE LEVEL MOTOR RUNS TO MECH STOP UNLESS CMD OFF

PSE COMMANDS

<u>OCTAL CMD NUMBER</u>	<u>CMD</u>	<u>OCTAL CMD NUMBER</u>	<u>CMD</u>
<u>063</u>	<u>PSE/XY GAIN CH</u>	<u>074</u>	<u>LVL DIR POS/NEG</u>
SWITCHES DIFFERENT ATTN INTO LPX & LPY CKTS TO CONTROL GAIN. REPEATED CMD SUCCESSIVELY STEPS ATTN THRU VALUES OF 0 DB, -10 DB, -20 DB, -30 DB. CMD CONTROLS CAL CURRENT OF LPX & LPY. ATTN RESET TO -30 DB UPON PSE ACTIVATION		REVERSES DIRECTION OF LEVEL MOTORS LPX, LPY, LPZ IN THE FORCED LEVEL MODE. CMD IS BISTATE POS/NEG & IS SET TO POS UPON PSE ACTIVATION.	
<u>064</u>	<u>PSE/Z GAIN CH</u>	<u>075</u>	<u>LVL SPEED HI/LO</u>
AFFECTS LPZ CKT SIMILAR TO 063 ABOVE		CONTROLS SPEED OF LEVEL MOTORS LPX, LPY, LPZ IN THE FORCED LEVEL MODE. CMD IS BISTATE HI/LO & IS SET TO LO UPON PSE ACTIVATION.	
<u>065</u>	<u>PSE/SP CAL CH</u>	<u>076</u>	<u>PSE T CTL CH</u>
APPLIES CURRENT THRU SP CAL ATTN (SELECTED BY CMD 067) TO SP CAL COIL. SP CAL IS ALSO PERFORMED AUTO EVERY 12 HR UNDER TIMER CONTROL (UNLESS INHIBITED BY CMD 033). BY CMD 033). RESET TO OFF UPON PSE ACTIVATION.		CONTROLS SENSOR HEATERS BY SELECTING OFF, FORCED-ON, OR AUTO MODES. 4-STATE CMD IS SET TO AUTO-ON UPON PSE ACTIVATION. SUCCESSIVE CMD STEPS THRU MODES IN THIS SEQUENCE:	
<u>066</u>	<u>PSE/LP CAL CH</u>	AUTO-OFF +29 VDC DISCONNECTED FROM HEATER FORCED-ON +29 VDC CONNECTED TO HEATER, AUTO THERMOSTAT CONTROL BYPASSED FORCED-OFF +29 VDC DISCONNECTED FROM HEATER AUTO-ON +29 VDC CONNECTED TO HEATER, AUTO THERMOSTAT CONTROL ENABLED	
APPLIES CURRENT THRU LP CAL ATTN (SELECTED BY CMD 063 & 064) TO THE LP DAMPING COILS (3 AXES). CMD IS BI-STATE ON/OFF & IS SET TO OFF UPON PSE ACTIVATION		<ul style="list-style-type: none"> • CMD DOES NOT CONTROL HEATER IN PSE CENTRAL STATION ELECTRONICS • CMD DOES NOT CONTROL SENSOR HEATERS WHEN PSE IS IN EXP 1 STBY SEL (CMD 037). 	
<u>067</u>	<u>PSE/SP GAIN CH</u>	<u>101</u>	<u>PSE FILT IN/OUT</u>
AFFECTS SP CKT SIMILAR TO 063 ABOVE		REMOVES FEEDBACK LOOP FILTERS FROM LPX, LPY, LPZ. CMD IS BI-STATE IN/OUT & IS SET TO OUT UPON PSE ACTIVATION. FOR PROPER PSE OPERATION, CMD OUT FOR LEVELING AND IN OR OUT FOR CALIB & FOR NORM OPER	
<u>070</u>	<u>LVL MTRX ON/OFF</u>	NOTE: DO NOT TRANSMIT THIS CMD WHEN ANY LEVEL MOTOR IS ON IN MANUAL MODE CMD HAS NO EFFECT. DO NOT SEND CMD WHEN IN AUTO MODE.	
APPLIES POWER TO X-AXIS DRIVE MOTOR. CMD IS BI-STATE ON/OFF & IS SET TO OFF UPON PSE ACTIVATION. MOTOR CONSUMES POWER UNTIL CMD OFF. NOTE: ONLY ONE DRIVE MOTOR TO BE ON AT ONE TIME		<u>102</u>	<u>LVL SNSR IN/OUT</u>
<u>071</u>	<u>LVL MTRY ON/OFF</u>	ALLOWS COARSE LEVEL SENSORS TO CONTROL LPX & LPY DRIVE MOTORS IN THE AUTO LEVEL MODE. CMD IS BI-STATE IN/OUT & IS SET TO OUT UPON PSE ACTIVATION.	
AFFECTS Y-AXIS SIMILAR TO 070 ABOVE		<u>103</u>	<u>PSE LVL MDE A/F</u>
<u>072</u>	<u>LVL MTRZ ON/OFF</u>	SELECTS LEVELING MODE OF LPX, LPY & LPZ. CMD IS BI-STATE AUTO/FORCED & IS SET TO AUTO UPON PSE ACTIVATION. NOTE: DO NOT TRANSMIT THIS CMD WHEN ANY LEVEL MOTOR IS ON	
AFFECTS Z-AXIS SIMILAR TO 070 ABOVE BUT ADJUSTS LACOSTE SPRING NOTE: DO NOT SEND WHILE EXPERIMENT IS CAGED - WILL DESTROY SENSOR.			
<u>073</u>	<u>UNCAGE ARM/FIRE</u>		
IRREVERSIBLE FUNCTION NECESSARY TO OBTAIN PSE SCIENTIFIC DATA. FIRST CMD ARMS. SECOND CMD FIRES ACTUATOR UNCAGING ALL SPRING MASS SYSTEMS. SUBSEQUENT CMDs WILL ARM AND THEN ATTEMPT FIRE USING PWR WITHOUT AFFECTING CAGE CONDITION. ARM & FIRE ALSO ACCOMPLISHED BY 12 HR TIMER PULSES 3 BY 96 HR + 2 MIN PULSE FROM DELAYED CMD SEQ, THEREFORE ARM IS ACCOMPLISHED BY CMD 073 OR 12 HR TIMER PULSE OR 96 HR + 2 MIN PULSE AND FIRE (WHEN IN THE ARM STATE) IS ACCOMPLISHED BY THE NEXT CMD 073 OR 12 HR TIMER PULSE OR 96 HR + 2 MIN PULSE.			

APR 69 5178.8.16

PSE MEASUREMENTS

MEASUREMENT NAME	SYMBOL	ALSEP WORD NO'S	ALSEP FRAMES	
PSE/X DATA	DL-01	9, 25, 41, 57	EVERY	} SCIENTIFIC
PSE/Y DATA	DL-02	11, 27, 43, 59	EVERY	
PSE/Z DATA	DL-03	13, 29, 45, 61	EVERY	
PSE TIDAL X DATA	DL-04	35	EVEN	
PSE TIDAL Y DATA	DL-05	37	EVEN	
PSE TIDAL Z DATA	DL-06	35	ODD	
PSE INST DEG F	DL-07	37	ODD	
PSE/SP DATA	DL-08	EVERY EVEN EXCEPT 2*, 46, AND 56	EVERY	
* IN ALSEP'S 1 AND 2				
PSE/XY GAIN DB	AL-01	33	23	} ENGINEERING
PSE/Z GAIN DB	AL-02	33	38	
LVL DIR/V STA	AL-03	33	53	
PSE/SP GAIN DB	AL-04	33	68	
LVL MODE SNSR STA	AL-05	33	24	
PSE T CTL STA	AL-06	33	39	
PSE/LP/SP CAL STA	AL-07	33	54	
PSE UNCAGE STATUS	AL-08	33	69	

DEC 67 5178.8.17

ACTIVE SEISMIC EXPERIMENT SUBSYSTEM

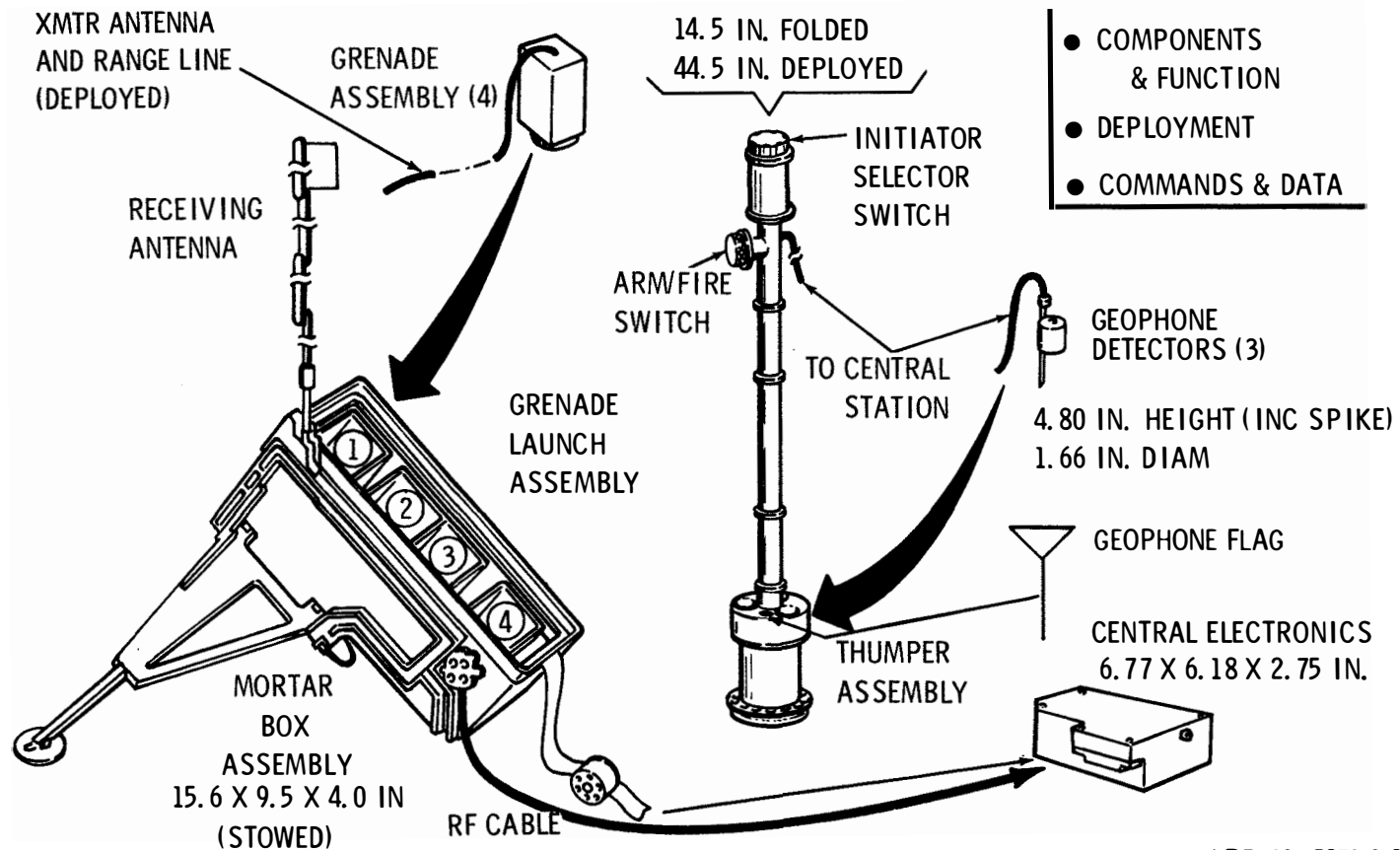

APR 69 5178.9.1

ASE GENERAL FEATURES

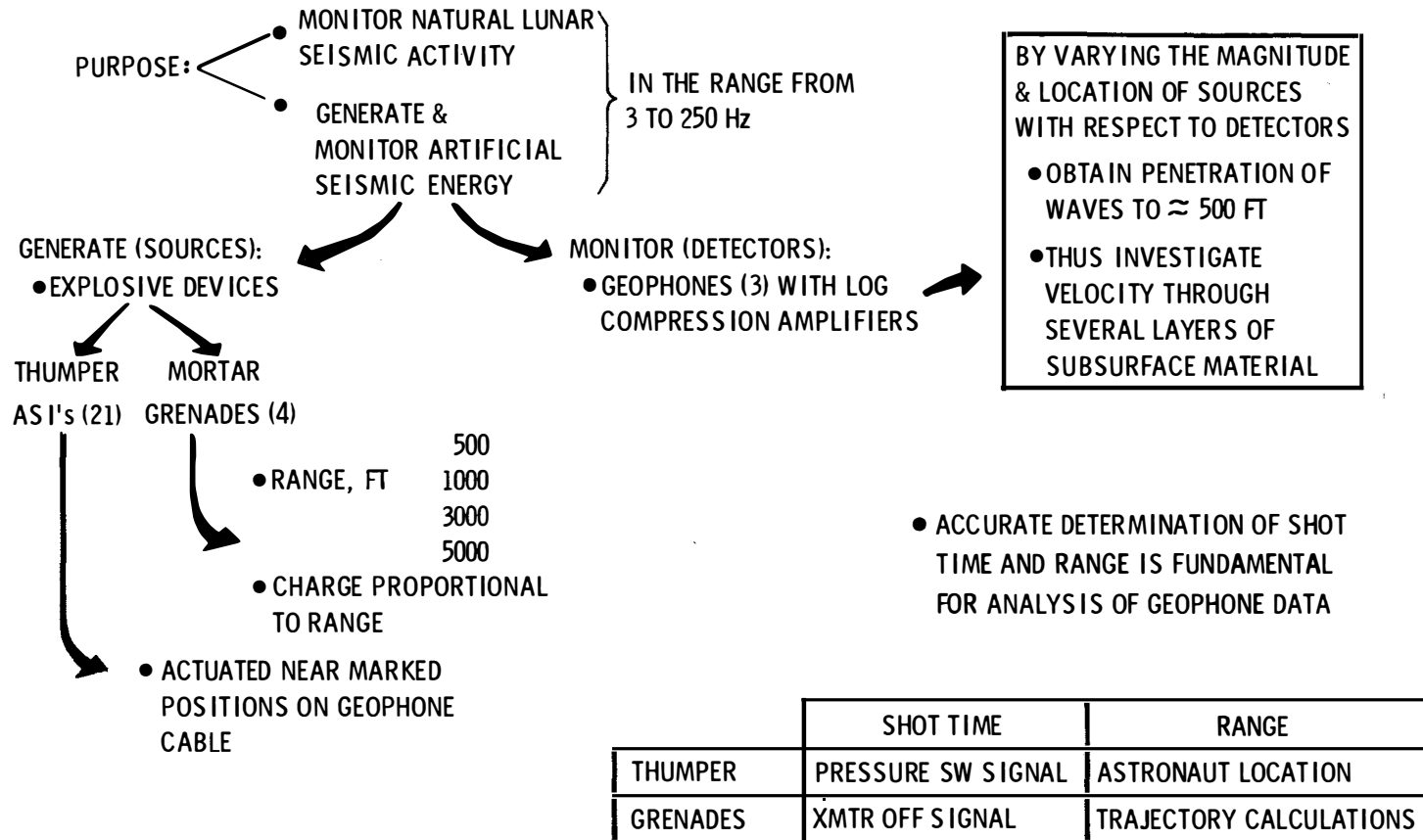

ASE FUNCTIONAL DIAGRAM

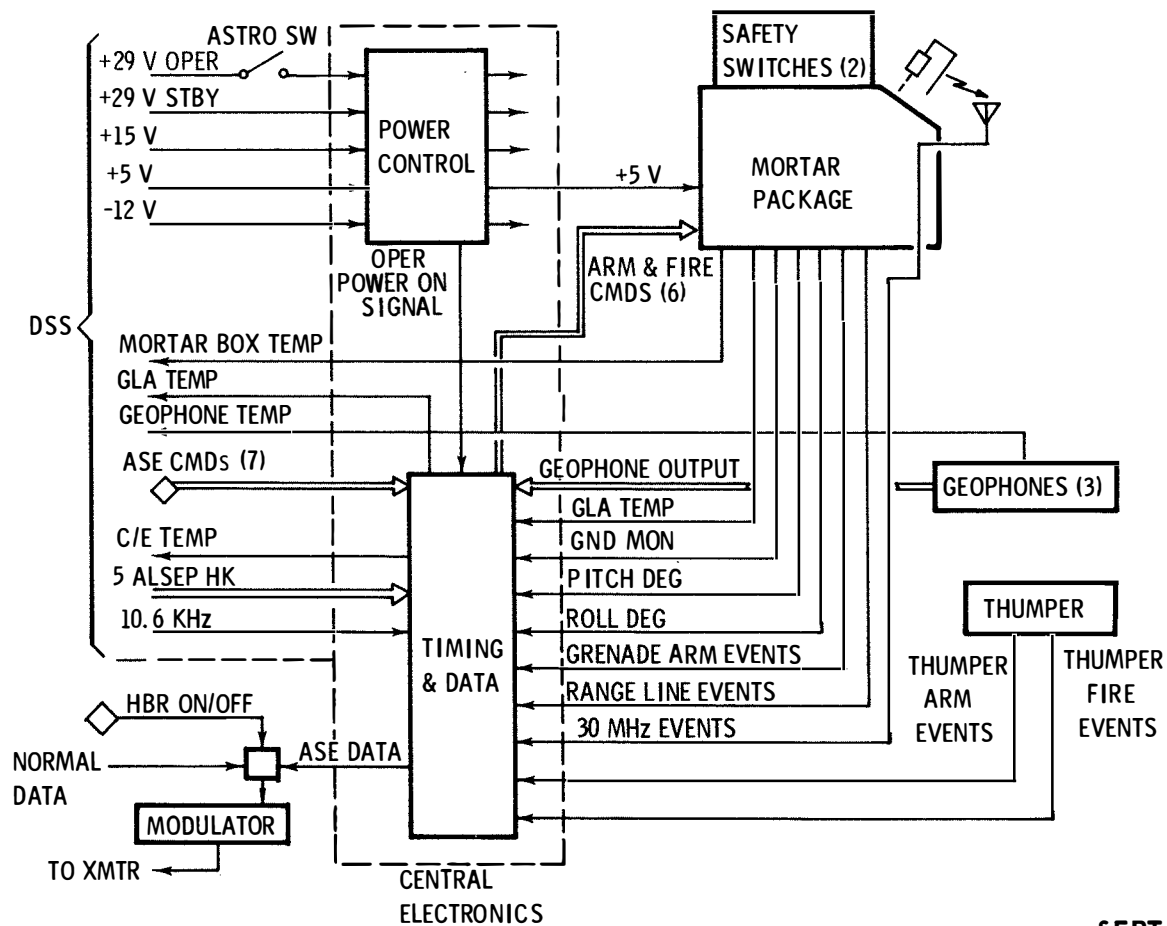

SEPT 68 5178.9.3

ASE THUMPER FUNCTION

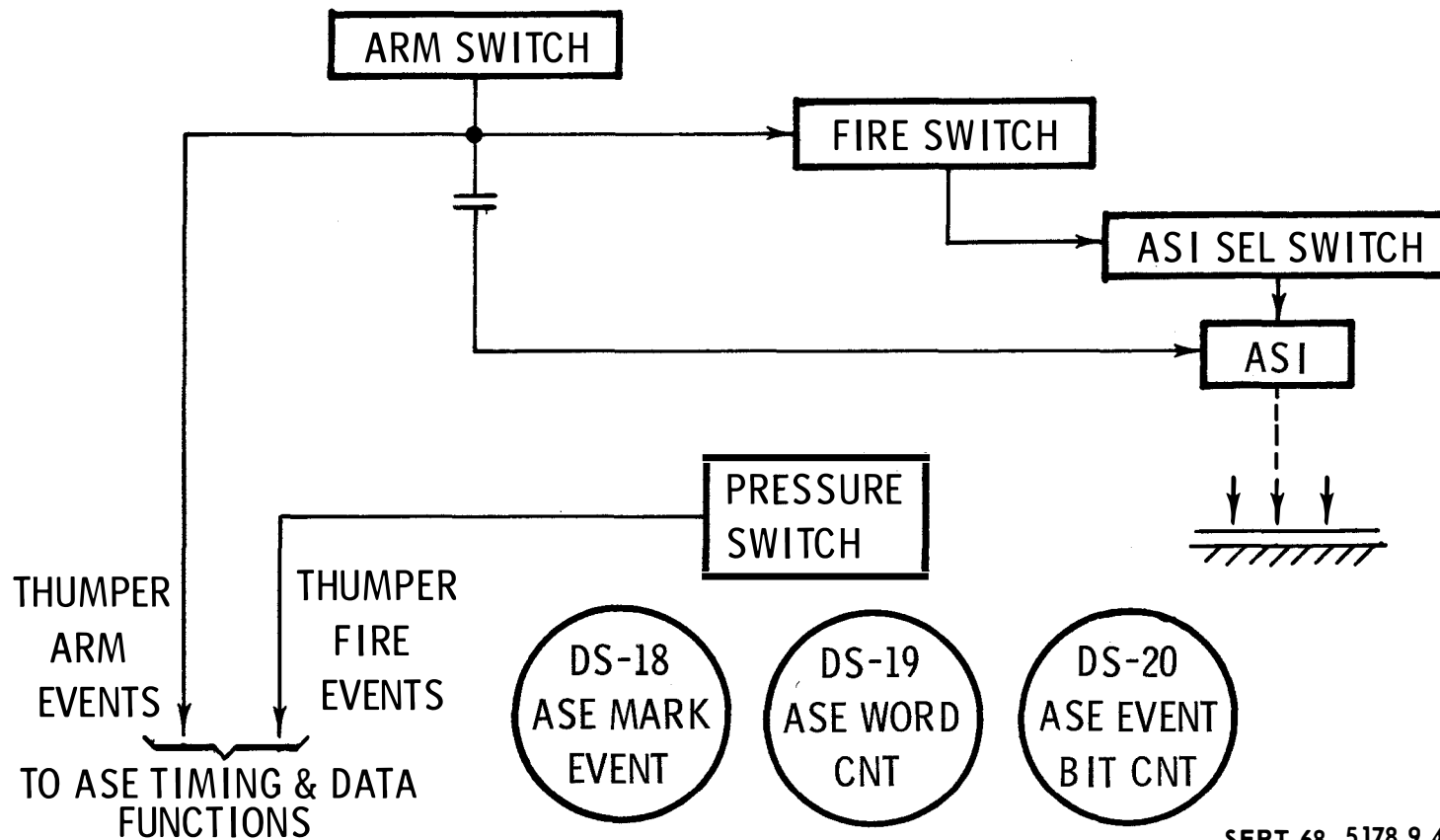

ASE THUMPER FEATURES

- INITIATOR (ASI) MOUNTING PLATE & BASE PLATE } { INSIDE LOWER END
- ARM/FIRE & ASI SELECTOR SWITCHES } { ON UPPER END
- FLAT, 4-CONDUCTOR CABLE TO CENTRAL ELECTRONICS } { ON UPPER SPLIT REEL } { UNWOUND DURING DEPLOYMENT
- 3 GEOPHONES WITH CABLES } { ON LOWER INTEGRAL REEL } { UNWOUND DURING DEPLOYMENT
- GEOPHONE FLAG
- PRESSURE SWITCH ON ASI MOUNTING PLATE DETECTS TIME OF SEISMIC EXPLOSION
- GEOPHONE FLAG DEPLOYED ON LUNAR SURFACE AT 150 FT TO AID IN GEOPHONE
- CABLE ALIGNMENT
- GEOPHONES AND CABLES STOWED ON THUMPER UNTIL DEPLOYED

ASE GEOPHONE FUNCTION

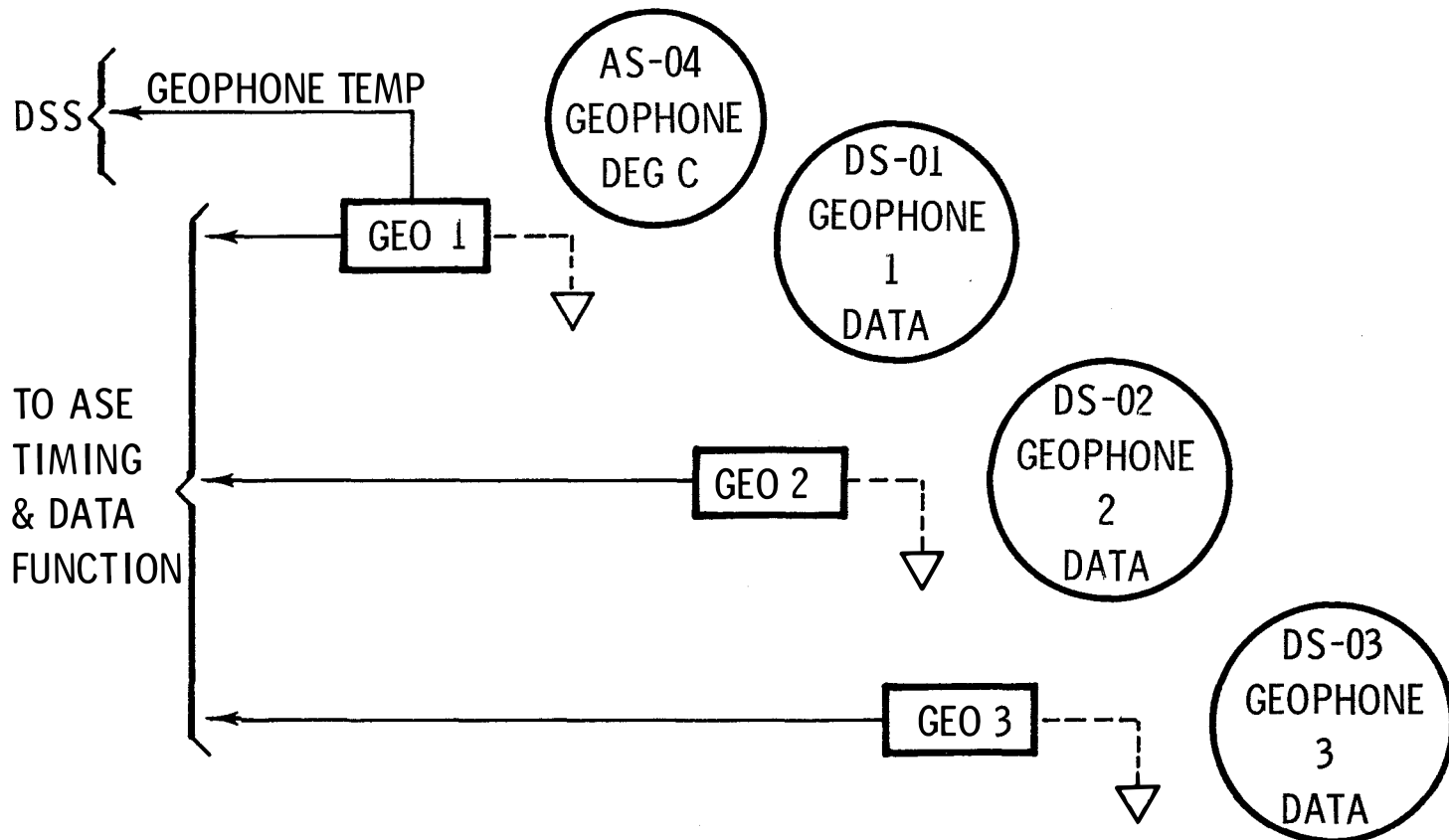

ASE GEOPHONE FEATURES

- ELECTROMAGNETIC TRANSDUCERS (VELOCITY SENSOR)
(OUTPUT TO SEPARATE LOG COMPRESSION AMPLIFIERS)
- IMPLANTED IN SURFACE BY SPIKE
- TEMPERATURE SENSOR IN ONE GEOPHONE
- 7.5 CPS NATURAL FREQUENCY
- SPRING CONSTANT DESIGNED FOR LUNAR GRAVITY

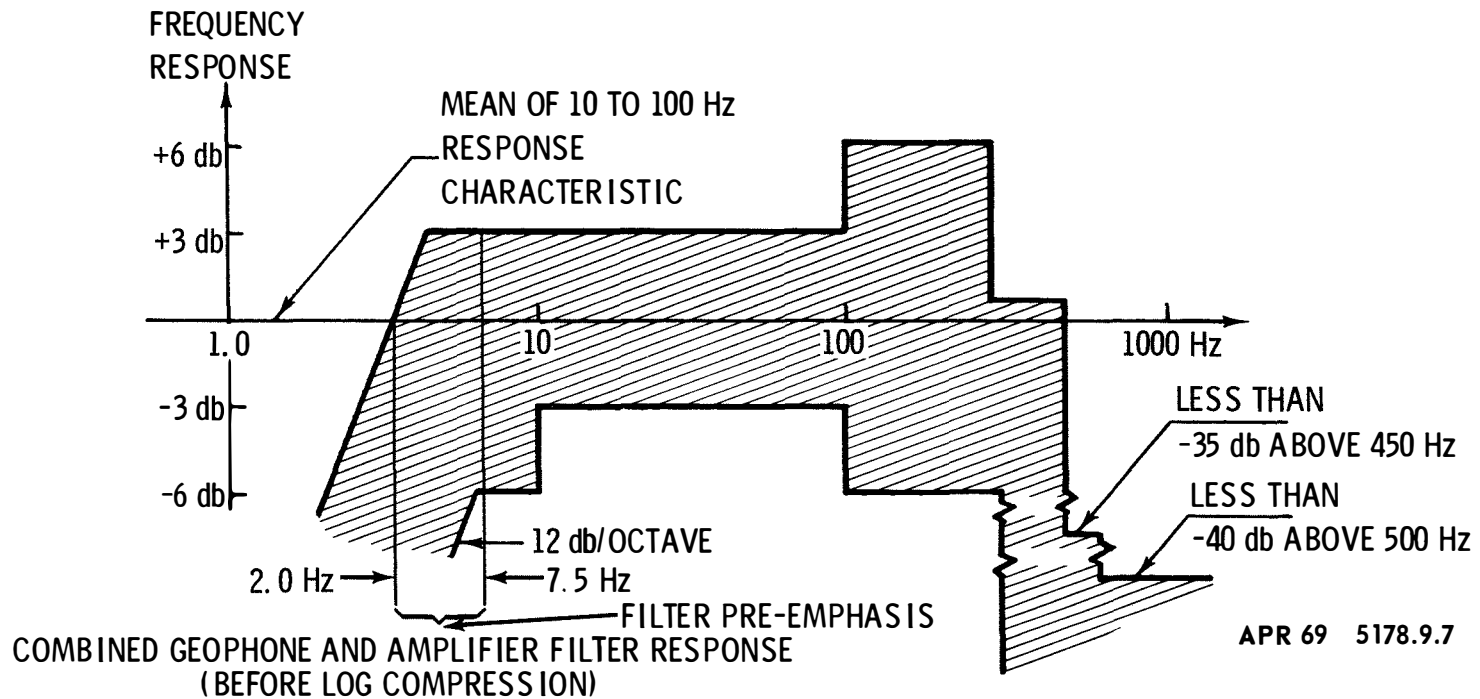

ASE MORTAR PACKAGE FUNCTION

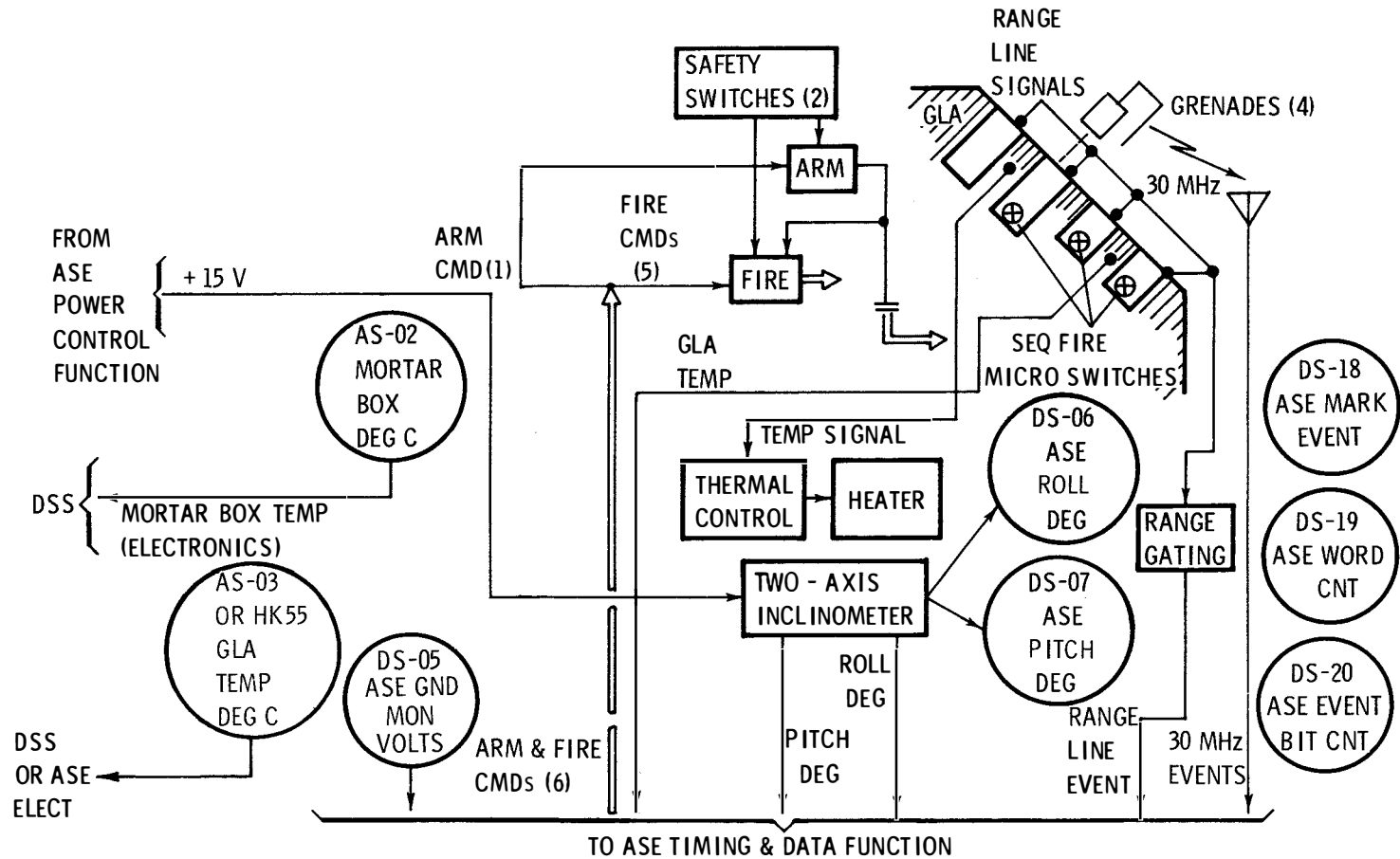

APR 69 5178.9.8

ASE MORTAR PACKAGE COMPONENTS

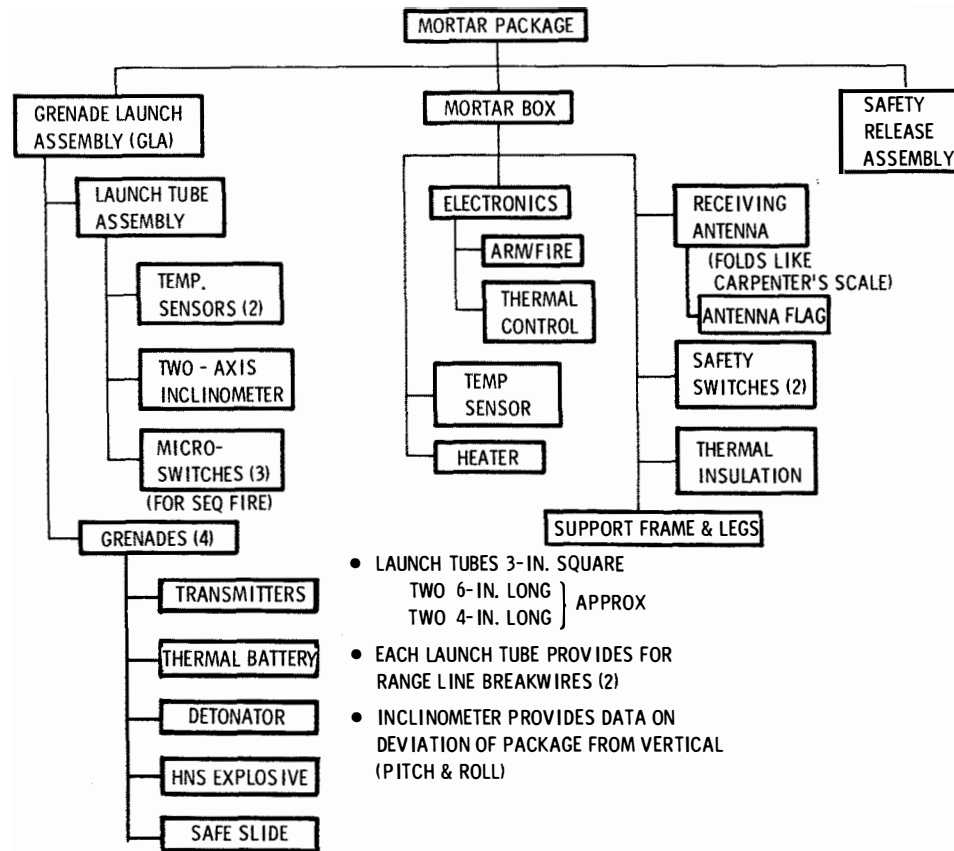

APR 69 5178.9.9

ASE GRENADE CHARACTERISTICS

DESCRIPTION

- CASING SIZE:
 - 2.7 IN. SQUARE } APPROX
 - 4 TO 6 IN. LONG }
- CASING CONTAINS:
 - SOLID FUEL ROCKET MOTOR
 - SAFE SLIDE
 - HIGH EXPLOSIVE CHARGE
 - IGNITION & DETONATION DEVICES
 - THERMAL BATTERY
 - 30MHz XMTR CONNECTED TO TRAILING WIRE ANTENNA (FUNCTIONS AS RANGE LINE)
- GRENADES DIFFER ONLY IN AMOUNT OF PROPELLANT & HIGH EXPLOSIVE

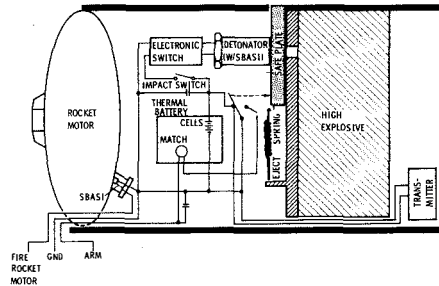

OPERATION

- GRENADE ARM CMD APPLIES PULSE TO ROCKET MOTOR ARMING CIRCUIT CHARGING CONDENSER IN MORTAR BOX AND CHARGES MATCH CONDENSER IN GRENADE)
- GRENADE FIRE CMD DISCHARGES CONDENSER THROUGH ASI IGNITING ROCKET MOTOR
- WHEN GRENADE LEAVES TUBE:
 - SPRING EJECTED SAFE SLIDE ENABLES DETONATOR
 - SLIDE EJECTION ACTIVATES MICROSWITCH IN GRENADE
 - MICROSWITCH DISCHARGES CONDENSER ACROSS MATCH ACTIVATING THERMAL BATTERY
- BATTERY PROVIDES INTERNAL POWER FOR:
 - 30 MHz XMTR
 - CHARGING DETONATOR CONDENSER
- EVENT MARK FOR:
 - BREAKWIRE (10-IN. & 25-FT + 10-IN. TRAVEL)
- AT IMPACT, AN OMNIDIRECTIONAL IMPACT SWITCH DISCHARGES CONDENSER THROUGH DETONATOR SETTING OFF HIGH EXPLOSIVE
- EXPLOSION DESTROYS BATTERY AND TRANSMITTER TERMINATING RF TRANSMISSION
- EVENT MARK FOR XMTR OFF

APR 69 5178.9.10

ASE GRENADE RANGING

CONCEPT

- BALLISTIC TRAJECTORY OF GRENADE IS CALCULATED FROM ITS INITIAL DIRECTION & TIME OF FLIGHT:
 - DIRECTION (45° ANGLE OF MORTAR CORRECTED BY INCLINOMETER ROLL & PITCH)
 - TIME-OF-FLIGHT FROM LAUNCH (FIRST RANGE LINE SIGNAL) TO IMPACT (XMTR OFF)
- CONFIDENCE IS ENHANCED BY KNOWING INITIAL LAUNCH VELOCITY (BASED ON TIME BETWEEN RANGE LINE EVENTS FOR 10-IN. & 25-FT + 10-IN. TRAVEL)

MECHANIZATION

- RANGE LINE: A THIN STRANDED CABLE WOUND AROUND THE OUTSIDE OF LAUNCH TUBE & CONNECTED AT ONE END TO GRENADE (30 MHz TRANSMITTING ANTENNA)
- BREAKWIRES (2): EACH A SINGLE LOOP OF FINE COPPER WIRE ARRANGED TO BE SEVERED WHEN RANGE LINE REACHES 10-IN. & 25-FT + 10-IN. POINTS
- INCLINOMETER: MEASURES DEVIATIONS AROUND TWO AXES
 - PITCH: INCREASE OR DECREASE IN THE 45° LAUNCH ANGLE
 - ROLL: ROTATION AROUND A HORIZONTAL AXIS PERPENDICULAR TO THE PITCH AXIS

IMPLICATIONS

- INCLINOMETER DATA IS AVAILABLE IN CASE MORTAR PACKAGE SHIFTS DURING EACH FIRING
- PACKAGE STABILITY ENHANCED BY 'BLOWOUT' REAR CLOSURE & THRUST TERMINATION BEFORE GRENADE LEAVES TUBE
- SEQUENTIAL FIRING ORDER (2, 4, 3, 1), ALSO USED FOR STANDARD FIRING, OPTIMIZES PACKAGE STABILITY
- NOTE THAT ARM CMD MUST BE SENT 4 TIMES (SEQUENTIAL & STANDARD CONDENSERS ARE CHARGED & DISCHARGED SIMULTANEOUSLY); ALSO, SEQUENTIAL FIRE ACTUATES ONE GRENADE EACH TIME SENT

ASE CENTRAL ELECTRONICS FEATURES

TIMING & DATA

- TEMP SENSING
INTERNAL TEMPERATURE MONITORED IN BASIC ALSEP DATA AS WELL AS ASE DATA STREAM
- LOG COMPRESSION AMPLIFIERS
LOW-NOISE, PROVIDE WIDE DYNAMIC RANGE
PRE-EMPHASIS TO INCREASE LOW FREQ GEOPHONE RESPONSE
- GEOPHONE CALIBRATION
 - DRIVER (PULSE STRETCHER) CONVERTS COMMAND INTO 1-SEC EXCITATION PULSE APPLIED VIA AMPLIFIERS
 - ELECTRICALLY DRIVES GEOPHONES FOR MEASUREMENT OF RESONANT FREQUENCY, GENERATOR CONSTANT, & DAMPING COEFFICIENT
 - COMPARE TO PREFLIGHT DATA (RELATIVE CALIBRATION)
 - PULSE VOLTAGE SAMPLED IN ASE DATA
- ANALOG MULTIPLEXER & ADC
 - ASE COMPRESSED SEISMIC DATA CONVERTED TO 5-BIT DIGITAL
 - ASE ENG & ALSEP HK (5 KEY PARAMETERS) CONVERTED TO 8-BIT DIGITAL, & BOTH READ OUT AS 4 BITS IN EACH OF TWO ASE WORDS
 - ADC CAL CIRCUIT GIVES 2-POINT CHECK

• TIMING & CONTROL

- 4, 5, & 32 SEQUENCE COUNTER OPERATES ON 10.6 KHz SQUARE WAVE FROM DSS
- PROVIDES FOR 5-BIT SUBWORDS, 4 PER ASE WORD (20 BITS) & 32 WORDS PER FRAME (640 BITS)
- DATA RATE, 10.6 KBPS (ALMOST ENTIRELY ASE DATA) GIVE:
 - RELATIVELY HIGH-FREQUENCY SEISMIC DATA
 - ACCURATE ENCODING & TRANSMISSION OF REAL-TIME EVENTS

POWER CONTROL

- ASE HAS NO DC/DC CONVERSION; ALL VOLTAGES SUPPLIED THROUGH DSS

• CURRENT LIMITERS

LINE, VOLTS	LIMIT, AMPS
+15	0.15
+ 5	0.50
-12	0.15

- POWER RESET BY SWITCHING +29 V
EXPER POWER OPER/STBY/OPER

APR 69 5178.9.12

ASE TIMING AND DATA FUNCTIONS

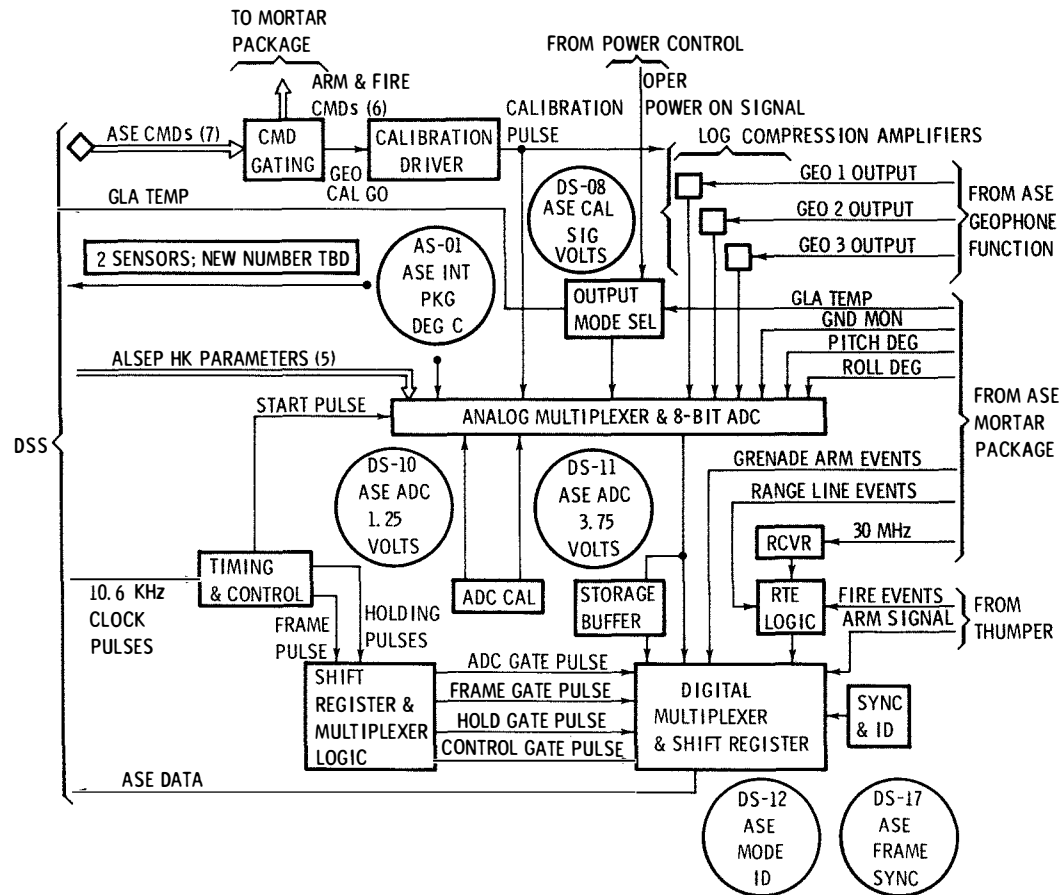

SEPT 68 5178.9.13

ASE POWER CONTROL FUNCTIONS

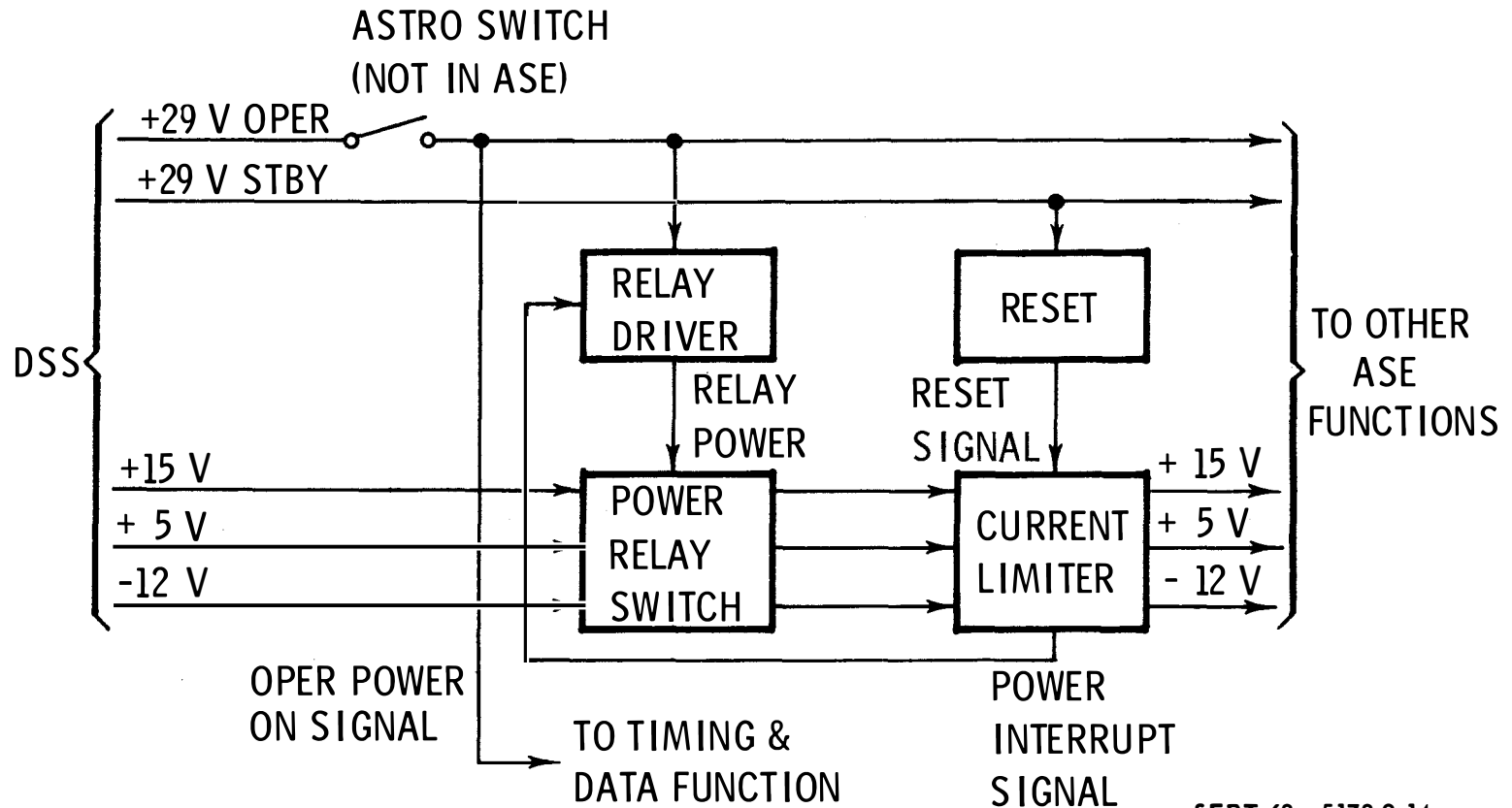

ASE THERMAL CONTROL

MECHANICAL

(MORTAR PACKAGE)

- 0.5-IN. MULTILAYER ALUMINIZED MYLAR ON SIDES & BOTTOM
- THIN ALUMINIZED MYLAR SUNSHIELD OVER TOP
- GRENADES LAUNCHED THROUGH SUNSHIELD
- ROCKET BLAST DISINTEGRATES MYLAR INSULATION REDUCING RECOIL EFFECT ON BOX STABILITY

ELECTRICAL

- MORTAR PACKAGE
 - ELECTRONIC SENSOR/CONTROL CIRCUIT OPERATES SERIES/PARALLEL HEATER ARRAY TO MAINTAIN TEMP ABOVE -60°C
 - PROPORTIONAL CONTROL, DISSIPATION IS A FUNCTION OF TEMPERATURE
 - CIRCUIT ACTIVATED ONLY IN STBY (NOTE: ASE IS IN STBY MOST OF THE TIME)
- CENTRAL ELECTRONICS IS CONTROLLED BY CENTRAL STATION ENVIRONMENT
- THUMPER HAS NO HEATER

ASE POWER PROFILE

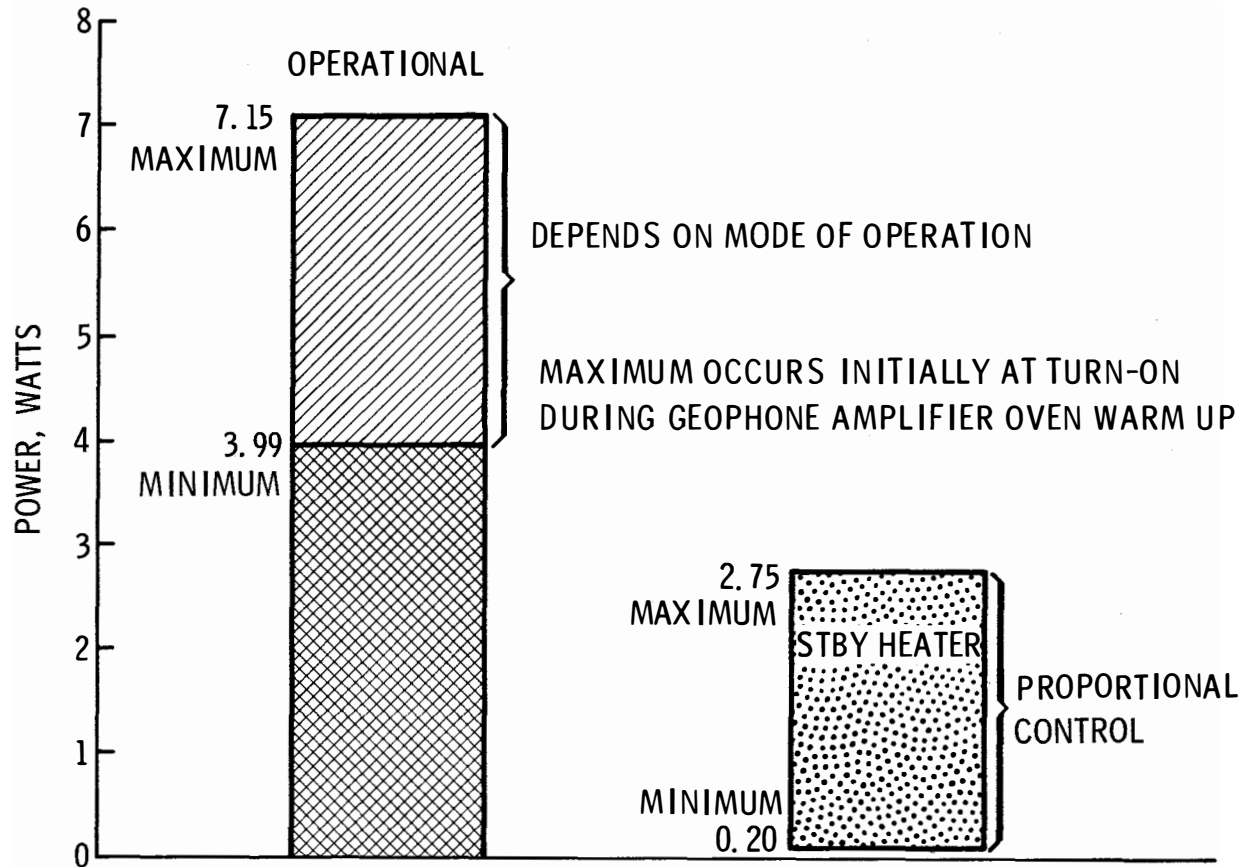

ASE SAFETY FEATURES

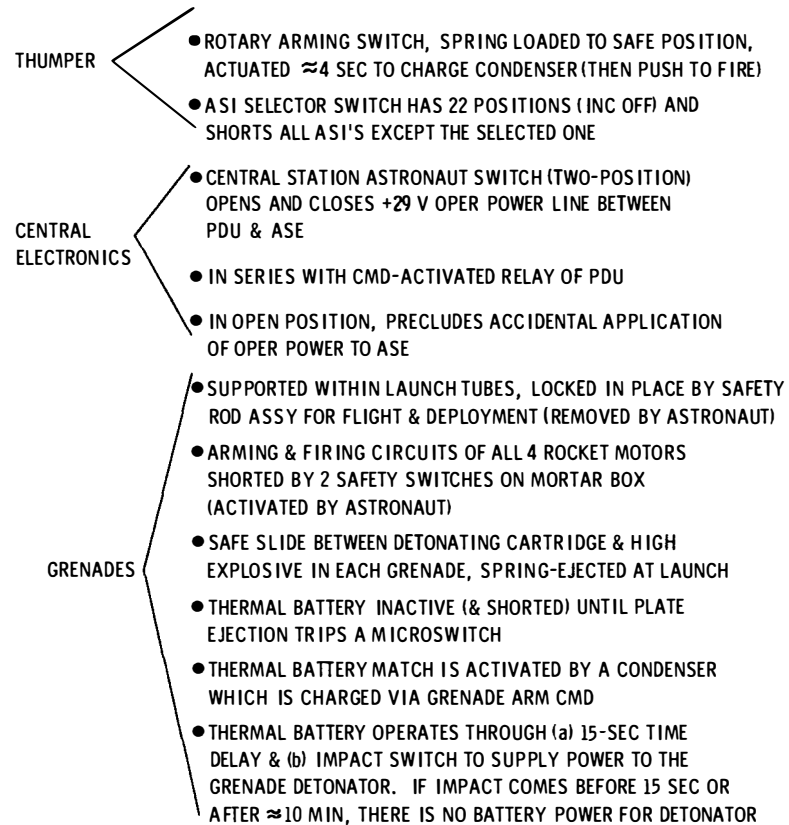

SEPT 68 5178.9.17

ASE DEPLOYMENT SEQUENCE

1. VERIFY THAT CENTRAL STATION
ASTRONAUT SWITCH IS IN OPEN POSITION } ← TENTATIVE
2. REMOVE THUMPER & PLACE IN TEMPORARY LOCATION
3. REMOVE MORTAR BOX & PLACE 10 FT FROM CENTRAL STATION
IN OPPOSITE DIRECTION TO THAT SELECTED FOR GEOPHONES
4. ALIGN TO FIRE AWAY FROM GEOPHONES & ERECT ASE RECEIVING
ANTENNA (INC FLAG)
5. ERECT CENTRAL STATION SUNSHIELD & ANTENNA
6. PLACE CENTRAL STATION ASTRONAUT SWITCH IN CLOSED POSITION } ←
7. AFTER ALSEP COMMUNICATIONS HAVE BEEN ESTABLISHED & SWITCHED
TO ASE HBR, UNFOLD THUMPER & WALK OUT IN SELECTED DIRECTION
PLACING GEOPHONES AT 10, 160, & 310 FT FROM CENTRAL STATION & IN
LINE $\pm 3^\circ$ USING FLAG ON MORTAR BOX (PLUS FLAG PLACED AT 160-FT
GEOPHONE LOCATION) AS REFERENCE
8. RETURN ALONG GEOPHONE CABLE ACTUATING THUMPER AT 15-FT
INTERVALS AS INDICATED BY CABLE MARKINGS
9. PLACE CENTRAL STATION ASTRONAUT SWITCH IN OPEN POSITION } ←
10. REMOVE GRENADE RETAINING ROD ASSY FROM MORTAR BOX
11. ACTUATE MORTAR BOX SAFETY SWITCHES (2) REMOVING SHORTS
FROM GRENADE ARM/FIRE CIRCUITS
12. PLACE CENTRAL STATION ASTRONAUT SWITCH IN CLOSED POSITION

ASE EMPLACEMENT DIAGRAM

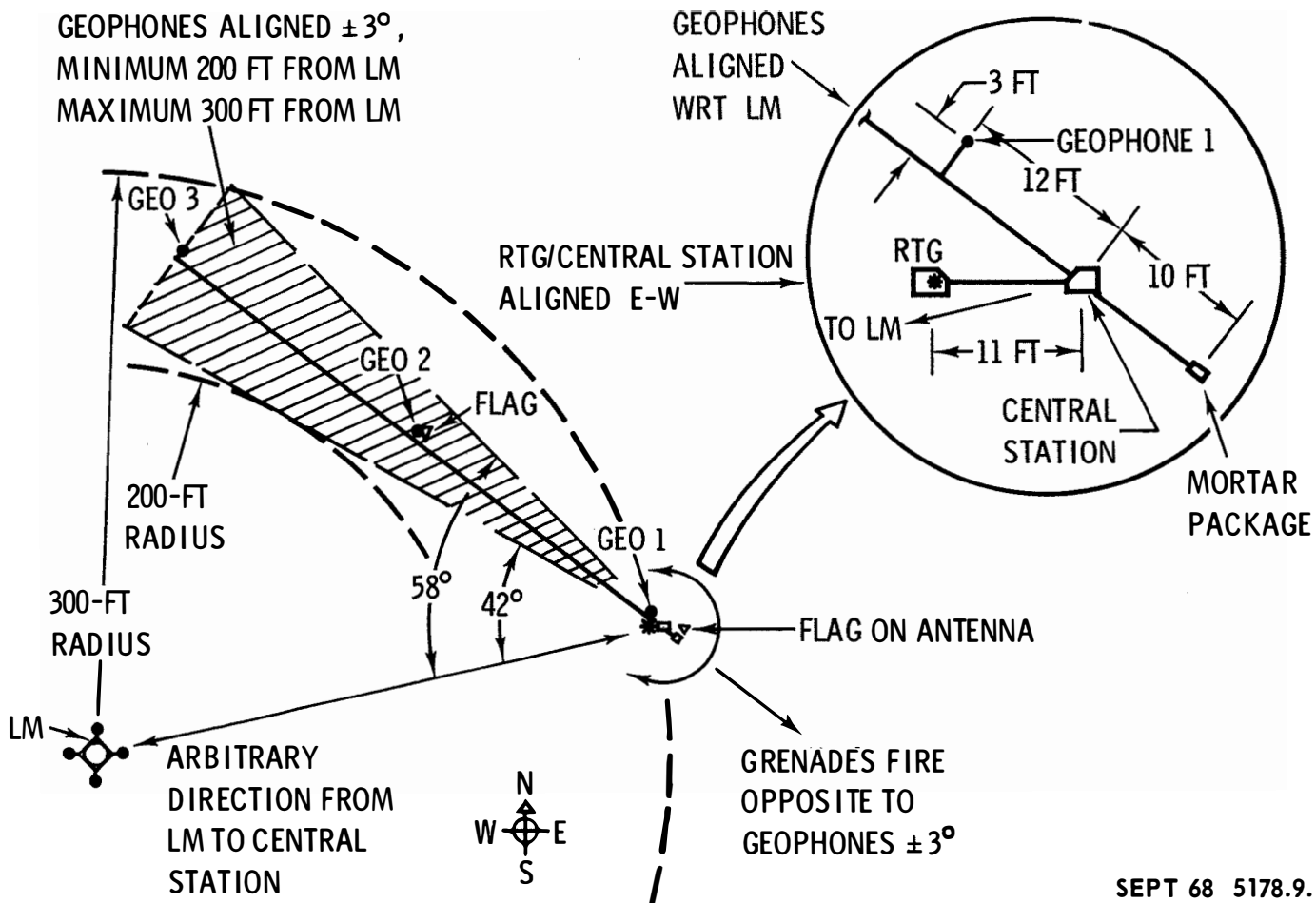

SEPT 68 5178.9.19

ASE EMPLACEMENT CRITERIA

	PARAMETER	REQUIREMENT	PRIORITY	INDICATOR	COMMENTS
MORTAR PKG	SITE SELECTION	LEVEL (UPRANGE & DOWNRANGE)	1	EYEBALL	SELECTION MUST CONSIDER BOTH GRENADE IMPACT & GEOPHONE AREAS
	DISTANCE FROM SUBPACKAGE 1	10 + 1 FT (11 FT CABLE)	2	PACED OFF	AT LEAST 10 FT FROM RTG
	DIRECTION FROM SUBPACKAGE 1	130 + 8° FROM LM *	2	EYEBALL	122° FOR 300 FT PLSS CONSTRAINT 138° FOR 200 FT LM SEPARATION
	LEVEL	+ 10° OF HORIZONTAL	1	EYEBALL	INTERNAL LEVEL SENSORS
	ALIGN	+ 3° FROM ASSUMED GEOPHONES DEPLOYMENT LINE	1	EYEBALL	FIRES AWAY FROM LM & GEOPHONES
GEOPHONES	DISTANCE FROM SUBPACKAGE 1	12 + 2 FT TO 1ST 150 + 1.5 FT 1ST TO 2ND 300 + 3 FT 1ST TO 3RD	1	314 FT CABLE	GEOPHONES SET LATERALLY FROM CABLE ON 3-FT PIGTAILS
	DIRECTION FROM SUBPACKAGE 1	50 + 8° FROM LM *	2	EYEBALL	OPPOSITE MORTAR PACKAGE
	LEVEL GEOPHONE	+ 7° OF HORIZONTAL	2	EYEBALL	GEOPHONE RESPONSE REQUIREMENT
	ALIGN CABLE	+ 3° FROM STRAIGHT	1	FLAGS **	VARIATION OF 2ND GEOPHONE FROM LINE BETWEEN 1ST & 3RD
SPECIAL REQUIREMENTS	<p>* 30° FROM N-S LINE OF SUBPACKAGE 1 TO AVOID FIELD OF VIEW OF CENTRAL STATION RADIATOR.</p> <p>**2 FLAGS: MORTAR BOX AND 2ND GEOPHONE (USED FOR ALIGNMENT) ANTENNA MOUNTED ON MORTAR BOX (OMNI-DIRECTIONAL).</p>				
EXPERIMENT INTERRELATION	**GEOPHONES AT LEAST 10 FT FROM RTG AND SUBPACKAGE 1				

SEPT 68 5178.9.20

ASE MODES OF OPERATION

THUMPER MODE: APPROX 7 MIN (PLUS SET UP) WHILE ASTRONAUT IS ON SURFACE. USES SMALL SEISMIC SOURCES RELATIVELY CLOSE TO GEOPHONES.

LISTENING (PASSIVE) MODE: 15 MINUTES, ONCE PER WEEK (AVERAGE). DETECTS TECTONIC DISTURBANCES OR METEOROID IMPACTS TO EVALUATE SYSTEM STATUS, PARTICULARLY LUNAR SURFACE NOISE LEVEL (WHICH MAY BE A FUNCTION OF AMBIENT TEMPERATURE), AND ASSIST IN SELECTING OPTIMUM TIME FOR MORTAR MODE.

MORTAR OR GRENADE MODE: APPROX 1 HR NEAR END OF ALSEP MISSION. USES RELATIVELY LARGE SEISMIC SOURCES AT RANGES UP TO 5000 FT.

NOTE: ALL MODES REQUIRE 85-FT MSFN ANTENNA BUT, WITH THE EXCEPTION OF THE THUMPER MODE, CAN BE SCHEDULED FOR MOST CONVENIENT GROUND OPERATIONS.

ASE COMMANDS

OCTAL COMMAND NUMBERS

003 ASE HBR ON

THIS CMD DISCONNECTS THE ALSEP DATA PROCESSOR FROM THE MODULATOR & CONNECTS THE MODULATOR TO THE ASE PROCESSOR WHICH SUPPLIES HBR DATA (10.6 KBPS).

THIS CMD TAKES EFFECT AT THE SCHEDULED END OF THE 64-WORD ALSEP FRAME DURING WHICH THE CMD IS RECEIVED.

THE DOWNLINK DATA IS MEANINGLESS IF THIS CMD IS EXECUTED WITH NO ASE ON BOARD OR IF ASE IS NOT OPERATING.

005 ASE HBR OFF

THIS CMD DISCONNECTS THE ASE PROCESSOR FROM THE MODULATOR & CONNECTS TO THE ALSEP DATA PROCESSOR WHICH SUPPLIES NBR (1.06 KBPS) OR LBR (0.53 KBPS) DEPENDING ON THE LATEST PREVIOUS BIT RATE CMD.

THIS CMD TAKES EFFECT AT THE SCHEDULED END OF THE 64-WORD ALSEP FRAME DURING WHICH THE CMD IS RECEIVED (ALSEP PROCESSOR OPERATES CONTINUOUSLY).

CENTRAL STATION ACTIVATION OR POWER RESET INITIALIZES ASE HBR OFF.

156 GEO CAL GO

THIS CMD INITIATES A 1-SEC CALIBRATION PULSE WHICH ELECTRICALLY EXCITES THE GEOPHONES. THE PULSE VOLTAGE ALSO APPEARS IN THE ASE DATA.

162 ASE SEQ FIRE

EACH TRANSMISSION OF THIS CMD FIRES A SINGLE ROCKET MOTOR (IF ARMED) IN THE 2, 4, 3, 1 FIRING ORDER. A GRENADES ARM CMD MUST PRECEDE EACH FIRE CMD. THE SEQUENCE IS CONTROLLED BY MICRO-SWITCHES IN THE LAUNCH TUBES; HENCE, PREVIOUS GRENADE MUST LAUNCH BEFORE NEXT MOTOR WILL FIRE.

163 GRENADE 1 FIRE

THIS CMD FIRES THE ROCKET MOTOR OF GRENADE 1, IF ARMED. THIS CMD (LIKE 164, 165 & 166) FOR A SPECIFIC GRENADE PROVIDES AN ALTERNATIVE TO CMD 162 FOR FIRING THE GRENADES.

164 GRENADE 2 FIRE

THIS CMD FIRES THE ROCKET MOTOR OF GRENADE 2, IF ARMED. SEE CMD 163.

165 GRENADE 3 FIRE

THIS CMD FIRES THE ROCKET MOTOR OF GRENADE 3, IF ARMED. SEE CMD 163.

166 GRENADE 4 FIRE

THIS CMD FIRES THE ROCKET MOTOR OF GRENADE 4, IF ARMED. SEE CMD 163.

170 GRENADES ARM

THIS CMD ARMS THE FIRING CIRCUIT APPLICABLE TO ANY OF THE 4 ROCKET MOTORS BY CHARGING A PAIR OF CONDENSERS, ONE FOR SEQUENTIAL FIRING & THE OTHER FOR SPECIFIC GRENADE FIRING. SUBSEQUENT ACTIVATION OF A FIRING CMD DISCHARGES BOTH CONDENSERS, ONE THROUGH A ROCKET MOTOR IGNITION ASI & THE OTHER THROUGH A GROUNDING CIRCUIT. IF NO FIRING CMD IS TRANSMITTED, THE CONDENSERS WILL REMAIN CHARGED INDEFINITELY; HOWEVER, THEY MAY BE RESET TO SAFE (DISCHARGED) BY SWITCHING THE ASE OFF (STBY) FOR A FEW SECONDS.

THIS CMD ALSO CHARGES THE THERMAL BATTERY MATCH CIRCUITS OF ALL 4 GRENADES (UNUSED CIRCUITS DISCHARGED BY FIRE CMD)

JAN 68 5178.9.22

ASE DATA FORMAT

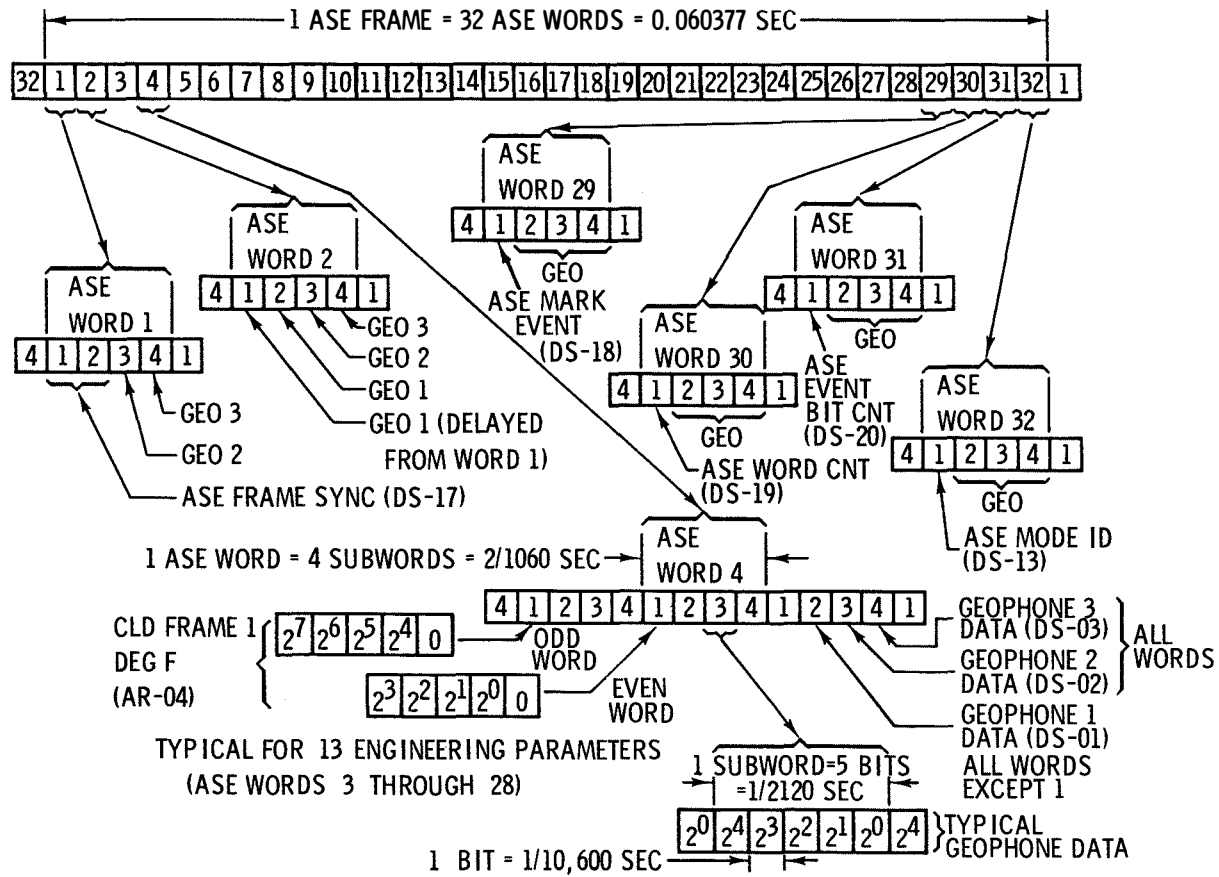

ASE REAL TIME EVENT DATA

-
- RTE SOURCES
- THUMPER FIRE: INITIATED BY PRESSURE SWITCH ON ASI MOUNTING PLATE
 - GRENADE LAUNCH: FIRST BREAKWIRE INDICATES 10-IN. TRAVEL
 - VELOCITY: SECOND BREAKWIRE INDICATES 25-FT + 10-IN. TRAVEL
 - IMPACT: XMTR OFF
- RTE READOUT
- MARK EVENT (ASE WORD 29): NON-ZERO PATTERN (00100) INDICATES THAT AN RTE HAS OCCURRED DURING THE PRECEDING 32-WORD FRAME
 - WORD COUNT (ASE WORD 30): INDICATES DURING WHICH WORD OF PRECEDING FRAME THE RTE OCCURRED (5 WORD COUNT BITS = 32 DECIMAL POSSIBILITIES)
 - EVENT BIT COUNT (ASE WORD 31): INDICATES DURING WHICH BIT IN THAT WORD THE RTE OCCURRED (ONE OF 20 BITS, GIVES NEAREST 0.1 M SEC)

ASE MODE ID

SPECIAL BIT PATTERNS FOR EACH OF THE FOLLOWING:

- THUMPER ARM: PICKOFF ON ARM/FIRE SWITCH ACTIVATES ID REGISTER WHICH MAINTAINS THIS PATTERN UNTIL 4 SEC AFTER THUMPER FIRES; REGISTER THEN CLEARS TO ZERO
- GRENADE ARM/FIRE: GRENADE ARM CMD ACTIVATES ID REGISTER WHICH MAINTAINS THIS PATTERN UNTIL CHANGED BY RECEIPT OF GRENADE FIRE CMD
GRENADE FIRE PATTERN IS MAINTAINED UNTIL CHANGED BY RECEIPT OF NEXT ARM CMD
PATTERN MAY BE RESET TO ZERO (REGISTER CLEARED) BY SWITCHING ASE OFF (STBY) & ON (OPER)
- GEOPHONE CAL: GEO CAL GO CMD ACTIVATES ID REGISTER FOR THE 1-SEC DURATION OF THE CALIBRATION PULSE; REGISTER THEN CLEARS TO ZERO

JAN 68 5178.9.25

ASE DATA OUTPUT

	SYMBOL	NAME	ASE FORMAT LOCATION	
			WORD	SUBWORD
ALSEP HK (5 KEY PARAMETERS) READ OUT IN ASE FORMAT	DS-17	ASE FRAME SYNC	1	1 & 2
	DS-02	GEOPHONE 2 DATA	ALL	3
	DS-03	GEOPHONE 3 DATA	ALL	4
	DS-01	GEOPHONE 1 DATA	{ 2 2-32	1 2
	AR-04	CLD FRAME 1 DEG F	3,4	1
4 ASE TEMPs READ OUT IN THE INDICATED ANALOG CHANNELS OF ALSEP WORD 33 (ALSEP 4)	AE-05	PCU 1 SHUNT AMPS	5,6	1
	DS-05	ASE GND MON VOLTS	7,8	1
	DS-06	ASE ROLL DEG	9,10	1
	DS-07	ASE PITCH DEG	11,12	1
	55 *	AS-03 ASE GLA DEG C	13,14	1
	DS-08	ADE CAL SIG VOLTS	15,16	1
	DS-11	ASE ADC 3.75 VOLTS	17,18	1
	DS-10	ASE ADC 1.25 VOLTS	19,20	1
	29 **	AS-01 ASE C/E DEG C	21,22	1
	AE-03	PCU IN VOLTS	23,24	1
	AE-04	PCU IN AMPS	25,26	1
	AR-01	HOT FRAME 1 DEG F	27,28	1
	DS-18	ASE MARK EVENT	29	1
	DS-19	ASE WORD CNT	30	1
DS-20	ASE EVENT BIT CNT	31	1	
DS-13	ASE MODE ID	32	1	
NOTE: ALSEP ANALOG CHANNELS SAMPLED ONCE PER 54 SEC ALSEP SEQUENCE	44	AS-02 MORTAR BOX DEG C	* SWITCHED BY ASE OPER POWER-ON SIGNAL	
	73	AS-04 GEOPHONE DEG C	** TWO SENSORS, NEW SYMBOL TBD	

ASE DATA ENCODING

ASE WORD 1

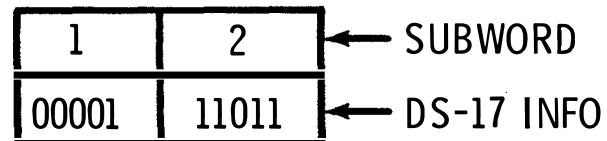

ASE WORD 30, SUBWORD 1

BIT	DS-20 INFO	BIT	DS-20 INFO
0	00001	10	10001
1	01100	11	11100
2	01110	12	11110
3	01111	13	11111
4	01011	14	11011
5	01001	15	11001
6	10100	16	00100
7	10110	17	00110
8	10111	18	00111
9	10011	19	00011

SEPT 68 5178.9.27



LUNAR SURFACE MAGNETOMETER EXPERIMENT SUBSYSTEM

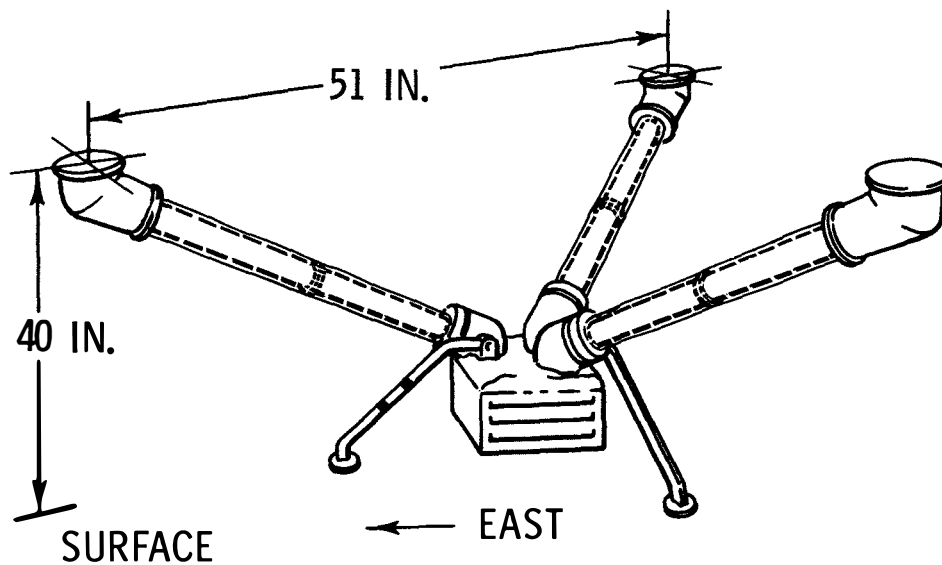

DEPLOYED

19.4 LB W/O CABLE

- COMPONENTS & FUNCTION
- COMMANDS & DATA
- DEPLOYMENT

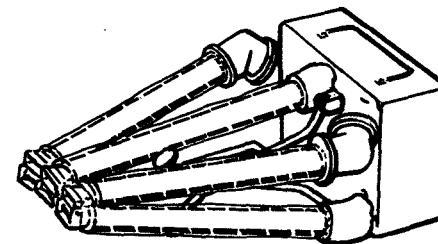

FOLDED

APR 69 5178.10.1

LSM FEATURES & PERFORMANCE

REQUIREMENT	CORRESPONDING FEATURE	
MEASURE MAGNETIC FIELD VECTOR	3 MAGNETIC SENSORS ALIGNED ALONG ORTHOGONAL AXES (X, Y, & Z)	
CAPABILITY FOR MEASURING BOTH DC & SLOW VARIATIONS OF FIELD	DIGITAL FILTERING OF SENSOR OUTPUT	
ACCOMMODATE UNCERTAINTY IN FIELD MAGNITUDE	RANGE SELECTION & PERCENTAGE OFFSET BY CMD HIGH OVERALL RESOLUTION	
OBTAIN HIGH OVERALL ACCURACY	HIGH-GAIN SENSOR OUTPUT 10-BIT ADC & SCIENCE TM (INC POLARITY SIGN)	ALIASING ERROR PROTECTION PRECISE MECHANICAL ALIGNMENT END-TO-END CAL BY CMD
MINIMIZE AMBIGUITY	MEASURE LOCAL FIELD GRADIENT (SITE SURVEY MODE) USE LOW INSTRUMENT BIAS SENSORS FLIP 180° BY CMD OR TIMER	
<ul style="list-style-type: none"> • PROVIDES BASIC DATA ON MAGNITUDE & TEMPORAL VARIATIONS OF THE LUNAR SURFACE EQUATORIAL MAGNETIC FIELD VECTOR • DATA TAKEN IN SOLAR & ANTI-SOLAR DIRECTION PROVIDES INFORMATION ON HOW INTERPLANETARY MAGNETIC FIELD DIFFUSES THROUGH MOON (ELECTROMAGNETIC PROPERTIES OF DEEP INTERIOR) • AID IN RECONSTRUCTING GEOLOGICAL EVOLUTION OF MOON • DETERMINE FEATURES OF MAGNETIC TAIL OF THE EARTH 		

RANGE	$\pm 100 \gamma$, $\pm 200 \gamma$, $\pm 400 \gamma$ (SELECTED BY CMD)
PERCENTAGE OFFSET	7 VALUES (SELECTED BY CMD) FOR EACH RANGE; 0, +25%, +50%, +75%, -75%, -50%, -25% OF NOMINAL FULL SCALE WITH AN ACCURACY OF 0.5% FULL SCALE
FREQ. RESPONSE	≈ 1.5 CPS
RESOLUTION	± 1 LSB (0.2% FULL SCALE)
CROSS-COUPLING	LESS THAN ± 1 LSB
MONOTONICITY	MONOTONIC OVER FULL RANGE; SATURATED OUTPUT VERIFIED TO 1000γ & AT EARTH'S FIELD ($\approx 35,000 \gamma$)
DC OFFSETS	LESS THAN $\pm 1\%$ FULL SCALE OVER OPER TEMP RANGE
SIMULTANEITY	ALL 3 SENSORS SAMPLED WITHIN 588μ SEC
PERIODICITY (TIME JITTER)	LESS THAN 100μ SEC
CALIBRATION (BY CMD OR TIMER) USES SAME CIRCUIT AS ZERO OFFSET & 14 STEPS IN SEQUENCE (0, +75%, +50%, +25%, 0, -25%, -50%, -75%, & REPEAT)	

SEPT 68 5178.10.2

LSM MODES OF OPERATION

- SCIENTIFIC MODE: NORMAL OPERATING MODE OF MAGNETIC FIELD SENSING
- SITE SURVEY MODE: PERFORMED ONCE (BY CMD) DURING EARLY OPERATIONS. ALL THREE SENSORS ALIGNED, IN SEQUENCE, TO THE X, Y, & Z AXES. PURPOSE OF SITE SURVEY IS TO IDENTIFY & LOCATE ANY MAGNETIC INFLUENCES PERMANENTLY INHERENT IN THE DEPLOYMENT SITE. THUS, THEIR EFFECTS (LOCAL FIELD GRADIENT) CAN BE CONSIDERED IN THE INTERPRETATION OF NORMAL SCIENTIFIC DATA
- CALIBRATION MODE: PERFORMED BY CMD OR AUTOMATICALLY (AT 12-HR INTERVALS) VIA ALSEP TIMER. PURPOSE OF CALIBRATION IS TO DETERMINE ABSOLUTE ACCURACY OF THE MAGNETIC SENSORS & CORRECT ANY DRIFT FROM THEIR LABORATORY CALIBRATION (DUE POSSIBLY TO RESIDUAL MAGNETIC PERMS ON THE SENSORS)

LSM FUNCTIONAL DIAGRAM

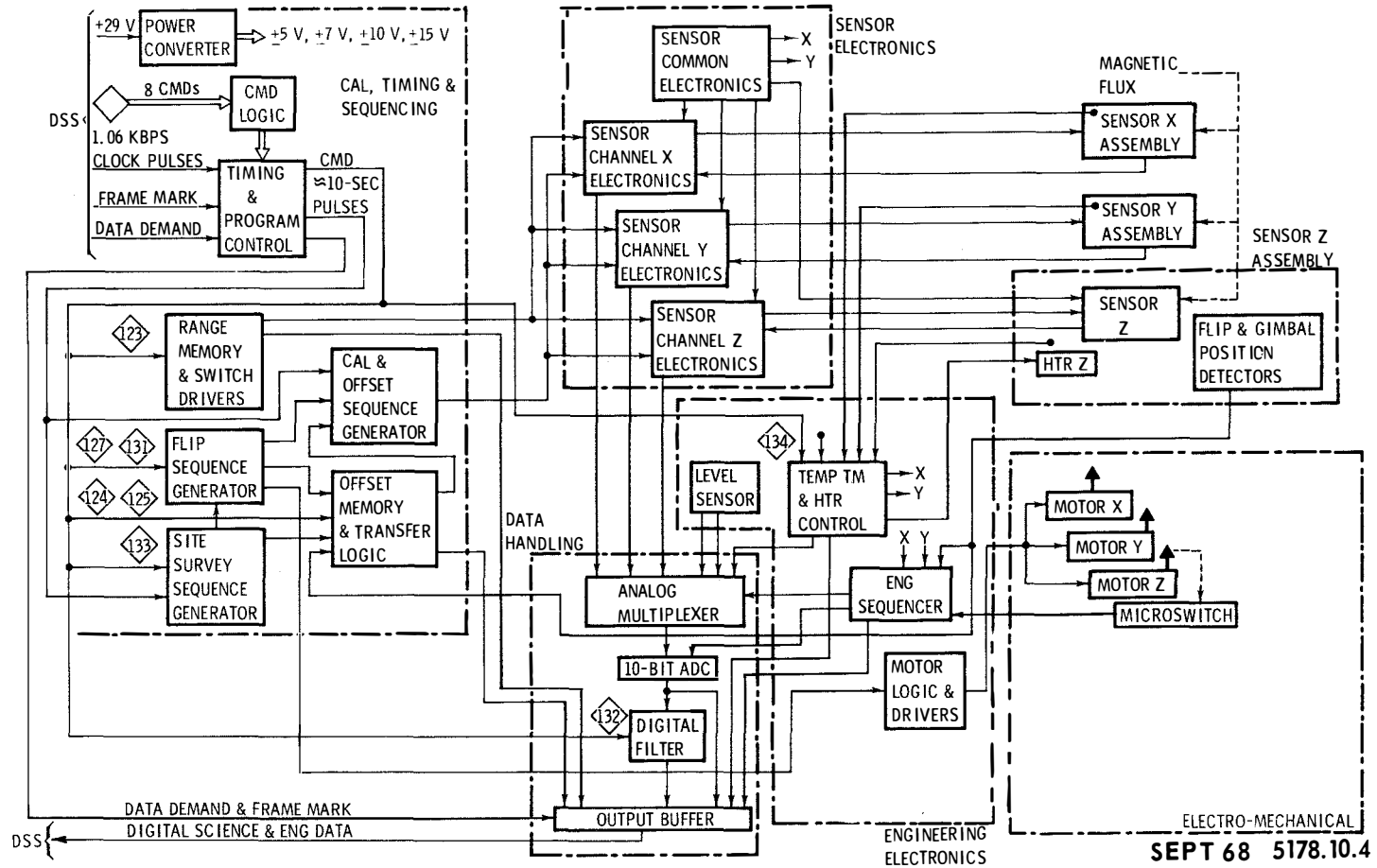

LSM ELECTRO-MECHANICAL

- ANGLE DEFINITIONS:
FLIP MOTION ROTATES SENSORS $+180^\circ$ IN THESE PLANES (FIRST $+90^\circ$ OF ROTATION SHOWN) & -180° RETURNS SENSOR TO ORIGINAL SETTING. AFTER GIMBAL MOTION, FLIP MOTION IS IN DIFFERENT PLANE

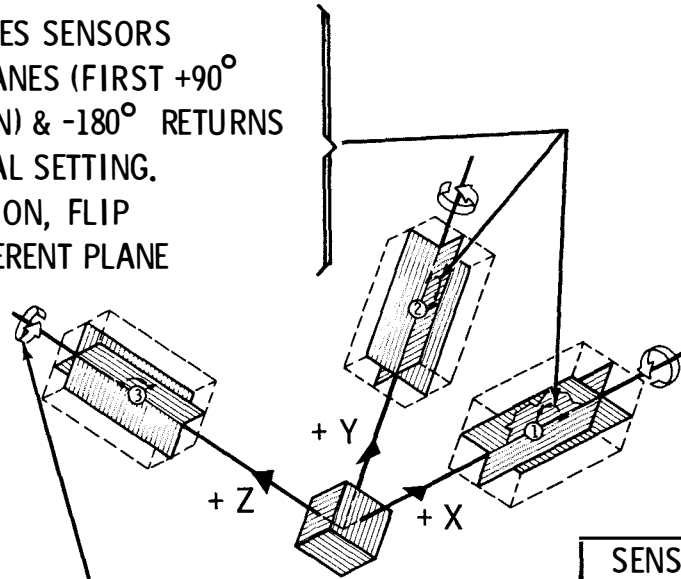

GIMBAL MOTION ROTATES SENSORS $+90^\circ$ IN THESE DIRECTIONS (ONCE FOR EACH SENSOR)

- STRUCTURAL SUPPORT
- SENSOR ARMS (BOOMS)
- ORIENTATION MECHANISMS
- MOTORS, STOPS

SENSOR DIRECTION FOR $0 \rightarrow +90^\circ \rightarrow +180^\circ$ FLIP		
SENSOR	PRE-GIMBAL	POST-GIMBAL
X ①	$+X \rightarrow +Y \rightarrow -X$	$+X \rightarrow +Z \rightarrow -X$
Y ②	$+Y \rightarrow +X \rightarrow -Y$	$+Y \rightarrow +Z \rightarrow -Y$
Z ③	$+Z \rightarrow +X \rightarrow -Z$	$+Z \rightarrow +Y \rightarrow -Z$

LSM EGFU AND SENSOR ARM

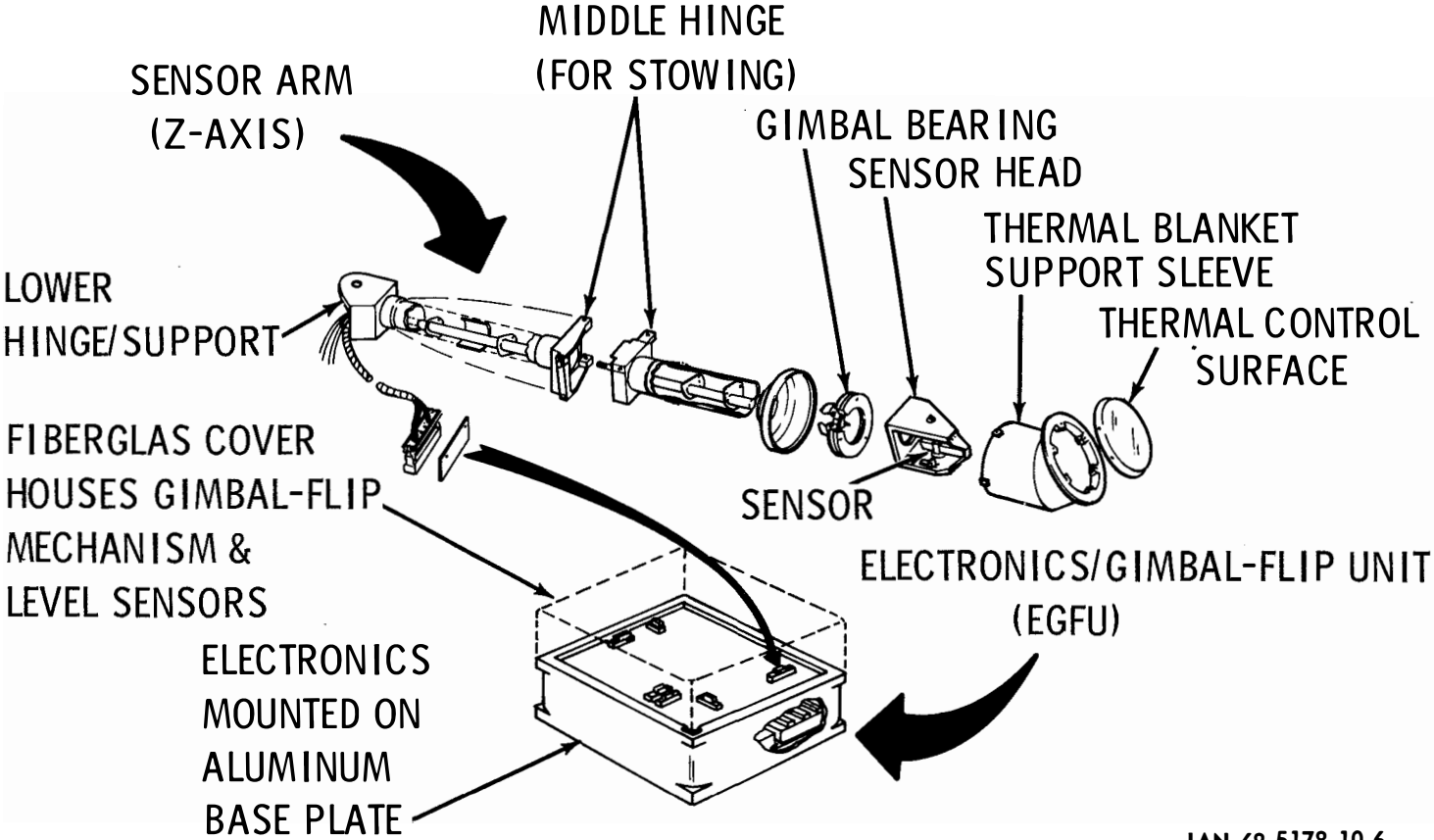

LSM ORIENTATION MECHANISM

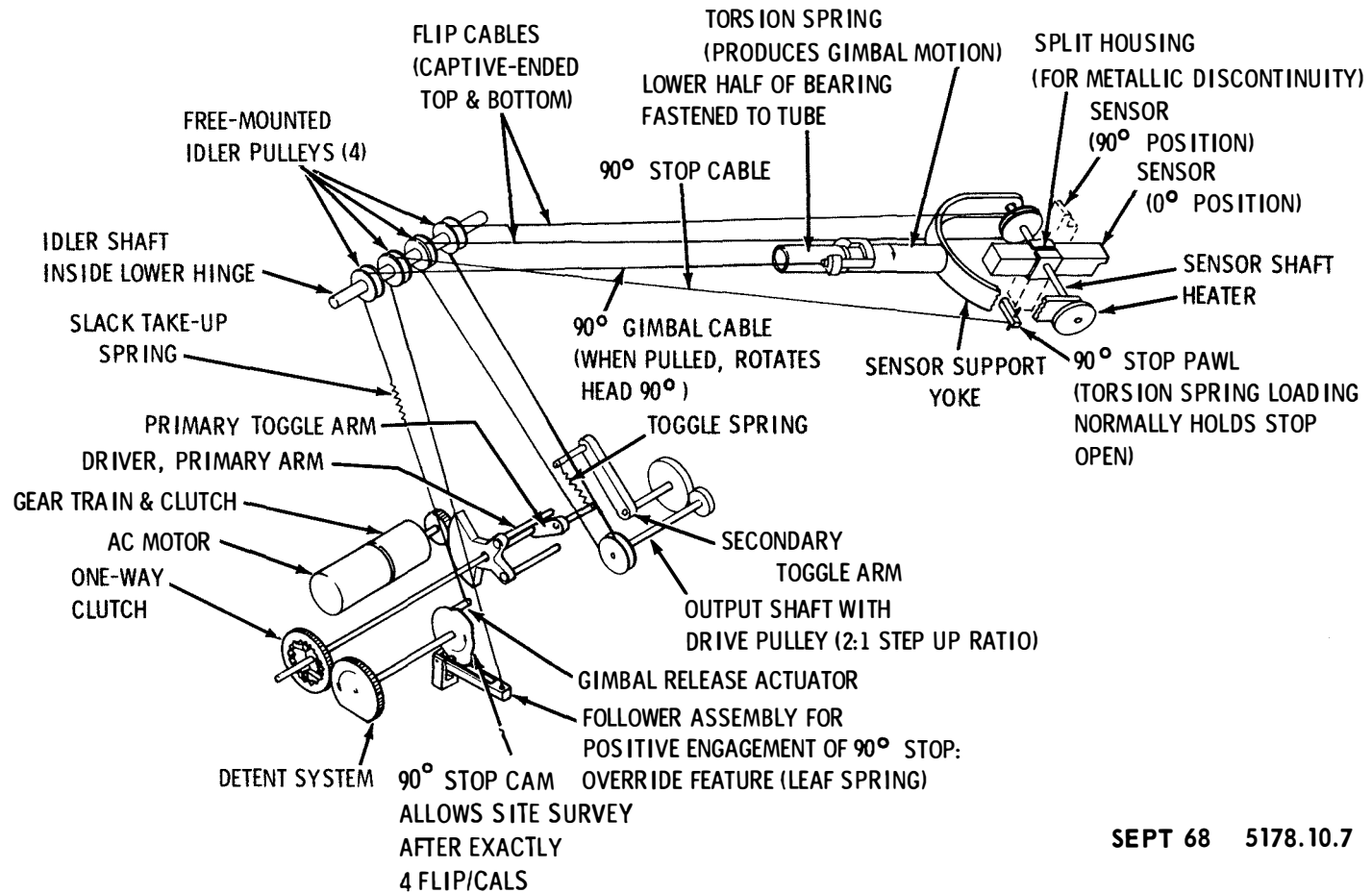

SEPT 68 5178.10.7

LSM MOTORS, STOPS, AND PISTONS

MOTORS: FLIPPING OF SENSORS IS POWERED BY INDIVIDUAL 400 ~, 2 ϕ AC MOTORS
(PHASE REVERSAL CAUSES MOTOR MOTION REVERSAL)

FLIP MOTION STOPS: THREE STOPS IN EACH SENSOR'S SUPPORT YOKE

- FIXED STOPS AT 0° & 180° (FLIP & SURVEY) } FOR ACCURATE CONTROL
- RETRACTABLE STOP AT 90° (SURVEY ONLY) } OF SENSOR POSITION

RETRACTABLE STOP:

- CONTROLLED BY CAM & FOLLOWER ASSEMBLY
- SPRING LOADED IN RETRACTED POSITION (OPEN)
- POWER FOR STOP INSERTION (CLOSED) FROM FLIP MOTOR VIA CAM/FOLLOWER
- USED ONCE (DURING SITE SURVEY) & THEN PERMANENTLY RETRACTED

GIMBAL MOTION: ROTATION OF SENSOR SUPPORT YOKE ABOUT SUPPORT ARM AXIS

- CONTROLLED BY GEAR TRAIN FROM FLIP MOTOR
- POWERED BY PRESET TORSION SPRING IN SENSOR ARM
- PERFORMED ONCE (SENSOR YOKE ROTATES 90°) DURING SITE SURVEY
- FLIP MOTION, 0° TO 180° & BACK, CAN BE PERFORMED IN EITHER SETTING (PRE-GIMBAL OR POST-GIMBAL)

SEPT 68 5178.10.8

LSM FLUX MEASUREMENT

- FLUX GATE MAGNETIC SENSORS, IN CONJUNCTION WITH SENSOR ELECTRONICS, PROVIDE ANALOG SIGNAL OUTPUTS PROPORTIONAL TO THE INTENSITY OF INCIDENT MAGNETIC FIELD COMPONENTS PARALLEL TO THE SENSORS
- CONVERSION SENSITIVITY: 20μ VOLTS PER γ AT 10 Hz
- SENSOR ELECTRONICS:
 - PROVIDES FUNDAMENTAL POWER (WITH NEGLIGIBLE SECOND HARMONIC) TO EXCITE THE FLUXGATE SENSORS
 - ACCEPTS SENSOR OUTPUT SIGNALS, SELECTING & AMPLIFYING ONLY THE SECOND HARMONIC COMPONENT
 - DEMODULATES THIS TO PROVIDE ANALOG OUTPUTS (FREQUENCY RESPONSE: DC TO 50 Hz)
 - PROVIDES FEEDBACK CURRENT TO THE SENSORS FROM THE ANALOG OUTPUTS
 - GENERATES FUNDAMENTAL & SECOND HARMONIC REFERENCE SQUARE WAVES (5.9625 & 11.925 KHz) DERIVED FROM 1.06 KHz ALSEP CLOCK PULSES

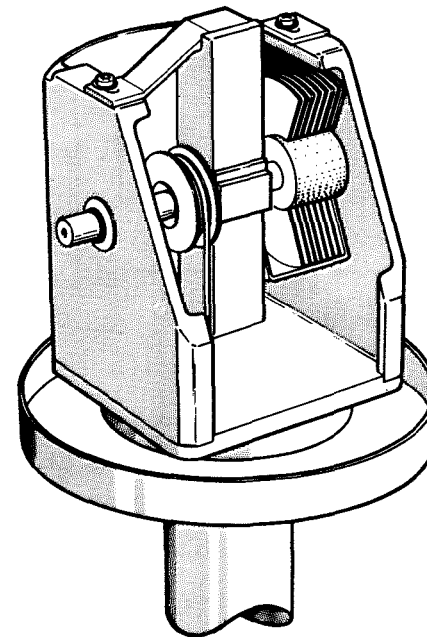

JAN 68 5178.10.9

LSM SENSOR ELECTRONICS

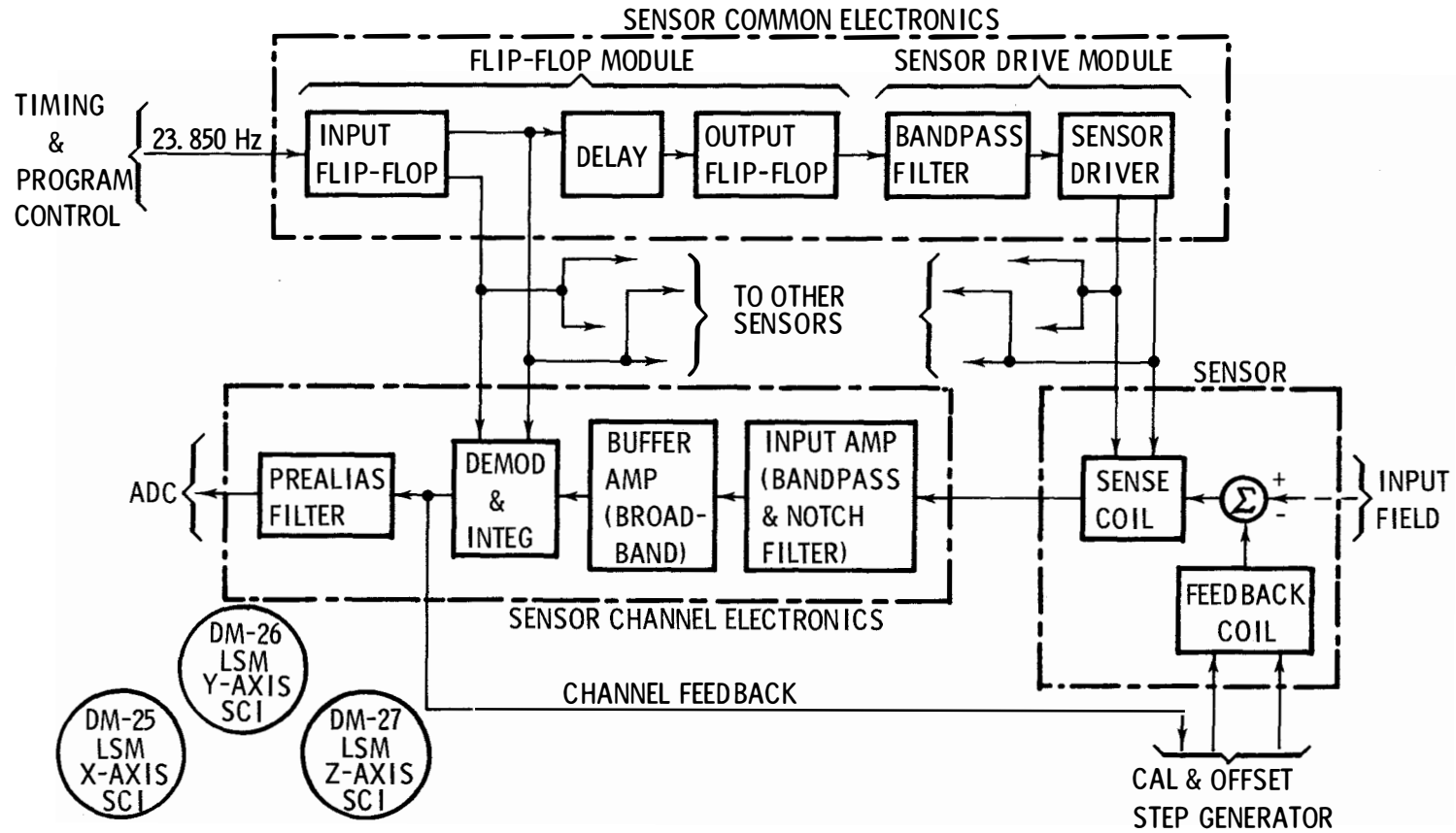

LSM CAL, TIMING, AND SEQUENCING

- RANGE COMMAND
- RANGE MEMORY & SWITCH DRIVERS
 - OFFSET COMMANDS
 - OFFSET MEMORY & TRANSFER LOGIC
 - TIMING & PROGRAM CONTROL
 - FLIP/CAL COMMANDS
 - FLIP/CAL SEQUENCE
 - CAL & OFFSET GENERATOR
 - SITE SURVEY COMMAND
 - SITE SURVEY SEQUENCE
 - POWER CONVERTER
 - POWER PROFILE

JAN 68 5178.10.11

LSM RANGE COMMAND AND FUNCTION

OCTAL CMD NUMBER

123 LSM RANGE STEPS

THIS IS A 3-STATE CMD THAT DETERMINES THE FULL-SCALE RANGE OF THE THREE SENSORS (X, Y & Z). LSM ACTIVATION PRESETS THE RANGE TO $\pm 400\gamma$. REPEATED TRANSMISSION OF THIS CMD STEPS THE RANGE THROUGH SEQUENTIAL VALUES ($\pm 400\gamma$, $\pm 100\gamma$, $\pm 200\gamma$, $\pm 400\gamma$, ETC.) THE SELECTED RANGE IS COMMON TO ALL 3 SENSORS.

FUNCTION

RANGE MEMORY & SWITCH DRIVERS

- MEMORY REGISTER, ADVANCED BY CMD 123, PROVIDES FOR SELECTION OF APPROPRIATE SWITCH DRIVERS
- SWITCH DRIVERS ACTIVATE SWITCHES IN CAL & OFFSET GENERATOR TO CONTROL SENSOR RANGE (BY MODIFYING GAIN IN FEEDBACK)
- REGISTER SETTING ALSO APPEARS IN LSM DATA

JAN 68 5178.10.12

LSM OFFSET COMMAND & MEMORY

OCTAL CMD NUMBER

124 LSM FLD O/S CH

THIS IS A 7-STATE CMD CONTROLLING FIELD OFFSET PERCENTAGE INDEPENDENTLY FOR EACH OF THE THREE SENSORS (X, Y & Z). LSM ACTIVATION PRESETS THE OFFSET TO 0%. REPEATED TRANSMISSION OF THIS CMD ADVANCES THE OFFSET THROUGH SEQUENTIAL VALUES (+25%, +50%, +75%, -75%, -50%, -25%, 0%, ETC.) PERCENTAGES ARE REFERENCED TO THE CURRENT FULL-SCALE RANGE AS SELECTED BY CMD 123 (EXAMPLE: WITH RANGE SET AT $\pm 100 \gamma$ BY CMD 123 & OFFSET AT +25%, FOR A PARTICULAR SENSOR, THE RESULTING RANGE FOR THAT SENSOR WOULD BE FROM -75γ TO $+125 \gamma$).

125 LSM O/S ADD CH

THIS IS A 4-STATE CMD USED TO ADDRESS THE THREE SENSORS (X, Y & Z) FOR OFFSETTING. LSM ACTIVATION PRESETS THE ADDRESS TO NEUTRAL (NO SENSOR IS ADDRESSED). REPEATED TRANSMISSION OF THIS CMD ADVANCES THE ADDRESS SEQUENTIALLY THROUGH X, Y, Z, NEUTRAL, ETC. (EXAMPLE: WITH ADDRESS SET BY CMD 125 to Y SENSOR, THE NEXT TRANSMISSION OF CMD 124 ADVANCES THE Y-SENSOR OFFSET ONE STEP WITHOUT AFFECTING THE X & Z SENSORS)

- OFFSET MEMORY & TRANSFER LOGIC STORES, IN RESPONSE TO CMDs 124 & 125, ONE OF THE 7 OFFSET (BIAS) LEVELS FOR EACH OF THE 3 SENSOR CHANNELS (X, Y & Z)
- STORED IN BINARY FORM IN A FLIP-FLOP MEMORY WHOSE OUTPUT STATES DRIVE THE APPROPRIATE OFFSET SWITCHES IN THE CAL & OFFSET GENERATOR
- MEMORY SETTING ALSO APPEARS IN LSM DATA
- TRANSFER LOGIC RECEIVES SENSOR POSITION DATA (FLIP & GIMBAL) & DERIVES APPROPRIATE SWITCH INPUTS (OFFSET LEVEL & POLARITY). EXAMPLE: DURING FLIP/CAL WHEN SENSOR ROTATES 180° , OFFSET POLARITY IS REVERSED. SIMILARLY, DURING X SITE SURVEY WHEN Y & Z SENSORS FLIP 90° (PARALLEL TO X AXIS) THEY ARE GIVEN THE X-AXIS OFFSET

LSM TIMING AND PROGRAM CONTROL

- GENERATES ALL TIMING & SYNCHRONIZATION SIGNALS NECESSARY TO SYNCHRONIZE THE DATA PROCESSING & SEQUENCING
- CONTAINS INTERNAL (COUNT-DOWN) CLOCK WHICH GENERATES TIMING SIGNALS FOR FLIP/CAL & SITE SURVEY SEQUENCES (\approx 10-SEC INTERVALS)

NOTE: LSM TIMING & FILTERING MATCHED TO ALSEP NORMAL BIT RATE (1.06 KBPS)
& WILL NOT PRODUCE VALID DATA AT SLOW RATE (0.53 KBPS)

LSM FLIP/CAL

OCTAL CMD NUMBER

127 FLIP/CAL INHIB

THIS IS A 2-STATE CMD (IN/OUT) USED TO INHIBIT THE FLIP/CAL SEQUENCE OF THE LSM. LSM ACTIVATION PRESETS THE LOGIC SO THAT FLIP/CAL IS INHIBITED. REPEATED TRANSMISSION OF THIS CMD STEPS THE SYSTEM BACK & FORTH BETWEEN INHIBIT IN & OUT. SINCE THE INHIBITED STATE ALSO PREVENTS FLIP/CAL VIA THE ALSEP TIMER (EVERY 12 HRS), THIS CMD MUST BE CONSIDERED CRITICAL (POSSIBILITY OF ALSEP LOSING UPLINK CAPABILITY)

131 FLIP/CAL GO

THIS IS A 1-STATE CMD TO INITIATE A FLIP/CAL SEQUENCE, UNLESS INHIBITED AS A RESULT OF CMD 127. ALSEP TIMER ALSO INITIATES FLIP/CAL SEQUENCE EVERY 12 HRS (UNLESS FLIP/CAL IS INHIBITED OR TIMER IS INHIBITED). UPON COMPLETION OF FLIP/CAL, LSM RETURNS TO NORMAL (SCIENTIFIC) MODE & SEQUENCER SHUTS OFF.
NOTE: THERE MUST BE EXACTLY 4 FLIP/CAL SEQUENCES BEFORE SITE SURVEY.

FLIP SEQUENCE GENERATOR

1. TRIGGERS CALIBRATION PORTION OF CAL & OFFSET GENERATOR TO APPLY SERIES OF CAL STEPS (RASTER) SIMULTANEOUSLY TO ALL 3 SENSORS (≈ 160 SEC)
 2. APPLIES POWER TO X MOTOR CAUSING X SENSOR FLIP (≈ 10 SEC)
 3. AFTER 10 SEC POWER TO X MOTOR IS SWITCHED OFF & Y MOTOR ON
 4. REPEAT STEPS 2 & 3 FOR Y MOTOR, SWITCHING TO Z UPON COMPLETION
 5. REPEAT STEP 2 FOR Z MOTOR
 6. CAL RASTER INITIATED AND APPLIED SIMULTANEOUSLY TO ALL 3 SENSORS (≈ 160 SEC)
 7. SIGNAL (CAL COMPLETE) TURNS OFF POWER TO FLIP SEQUENCE GENERATOR
- NOTES: A. OFFSET MEMORY & TRANSFER LOGIC REVERSES POLARITY OF EACH OFFSET WHEN ACTIVATED BY CHANGE IN FLIP POSITION DETECTORS (OFFSET ALSO APPEARS IN LSM DATA)
B. SPECIAL FLIP MOTIONS INITIATED ON DEMAND FROM SITE SURVEY SEQUENCE GENERATOR

LSM CAL AND OFFSET FUNCTION

- RANGE SELECTION: CHANGES SENSOR FEEDBACK GAIN
- % OFFSET (BIAS): INSERTED IN FEEDBACK LOOP OF SENSOR ELECTRONICS
- CALIBRATION (RASTER): SENSOR ELECTRONICS
- FEEDBACK CIRCUIT PROVIDES:
 - ACCURATE SUMMATION OF OFFSET, CALIBRATION, & FEEDBACK (DEMOD + INTEG) VOLTAGES AT ALL COMBINATIONS OF SIGNALS
 - LINEAR DRIVE OF FLUXGATE SENSOR FEEDBACK WINDING OVER WIDE DYNAMIC RANGE
- OFFSET GENERATOR: SWITCH DRIVERS (ONE SET FOR EACH SENSOR CHANNEL) CONTROLLED BY OFFSET MEMORY & TRANSFER LOGIC; ACTIVATE LADDER NETWORKS (7 STATES)
- CALIBRATION SEQUENCE GENERATOR:
 - GENERATES TWO IDENTICAL SEQUENCES (BEFORE & AFTER FLIP)
 - EACH SEQUENCE HAS 14 STEPS OF ≈ 10 SEC/STEP (≈ 10 -SEC CLOCK PULSES FROM TIMING & PROGRAM CONTROL)
 - EACH STEP ACTIVATES SWITCH DRIVER FOR SWITCHES IN CALIBRATION (LADDER) NETWORK OF CAL & OFFSET STEP GENERATOR
 - UPON COMPLETION OF SECOND SEQUENCE (AFTER FLIP) CLOCK INPUT IS INHIBITED & SIGNAL (CAL COMPLETE) IS SENT TO FLIP SEQUENCE GENERATOR

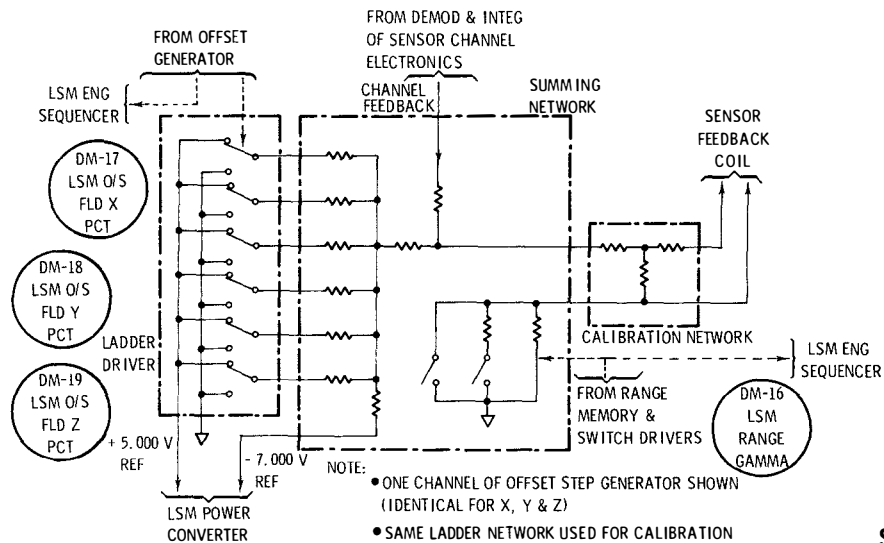

SEPT 68 5178.10.16

LSM SITE SURVEY (GENERAL)

OCTAL CMD NUMBER

133 SITE SURVEY XYZ

THIS IS A 1-STATE CMD TRANSMITTED THREE TIMES, IN SUCCESSION, TO ACTIVATE THE SITE SURVEY SEQUENCE GENERATOR. THE FIRST TRANSMISSION INITIATES THE SURVEY IN THE X-AXIS DIRECTION. UPON COMPLETION OF THE X-AXIS SEQUENCE, THE LSM RETURNS TO THE SCIENTIFIC (NORMAL) MODE OF OPERATION. THE SECOND AND THIRD TRANSMISSIONS OF THIS CMD INITIATE SURVEYS IN THE Y-AXIS & Z-AXIS DIRECTIONS, RESPECTIVELY, & AFTER EACH SURVEY THE LSM RETURNS TO THE SCIENTIFIC (NORMAL) MODE OF OPERATION. THE COMPLETE SITE SURVEY SEQUENCE IS PERFORMED ONLY ONCE. IT MUST BE PRECEDED BY EXACTLY 4 FLIP/CAL SEQUENCES.

- TO ACCOMPLISH SITE SURVEY, ALL THREE SENSORS ARE ALIGNED PARALLEL TO THE X-AXIS DIRECTION, Y-AXIS DIRECTION, & Z-AXIS DIRECTION (3 SUBSEQUENCES)
- USES COMBINATIONS OF PARTIAL (90°) FLIP MOTION & GIMBAL MOTION
- CONTROLLED BY SITE SURVEY SEQUENCE GENERATOR WHICH USES TIMING PULSES FROM TIMING & PROGRAM CONTROL
- OPERATES THROUGH FLIP SEQUENCE GENERATOR TO ACTIVATE FLIP MOTORS (MOTORS ALSO ACTUATE GIMBAL MOTION)
- 90° FLIP IS PROGRAMMED THROUGH CAMS & CAM FOLLOWERS
- POSITION DETECTORS (THROUGH OFFSET MEMORY & TRANSFER LOGIC) APPLY APPROPRIATE OFFSETS TO EACH SENSOR
- POSITION DETECTORS ALSO HAVE OUTPUTS IN LSM DATA
- DETENT SYSTEM PERMANENTLY DISENGAGES CAM TOGGING MECHANISM SO THAT 90° FLIP CAN NOT OCCUR AFTER COMPLETION OF SITE SURVEY
- CONTROLS SITE SURVEY (3 SUBSEQUENCES) IN RESPONSE TO 3 SUCCESSIVE GROUND CMDs
- CONSISTS OF A BINARY COUNTER WHICH STEPS ONE STEP AT THE COMPLETION OF EACH OPERATION
- COUNTER OUTPUTS ARE GATED; COINCIDENCE SIGNALS ACTIVATE THE FOLLOWING:
 - FLIP MOTOR POWER SWITCHING (3 MOTORS, EACH FWD & REVERSE)
 - CALIBRATION SEQUENCE INITIATION
 - SEQUENCE INHIBIT

OCT 68 5178.10.17

LSM X-AXIS SURVEY

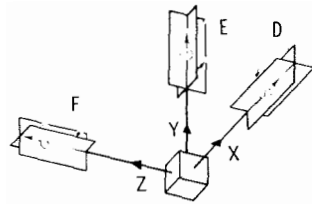

INITIAL POSITION
& FIRST ROTATIONS

- A. SENSORS INITIALLY IN SCIENTIFIC ORIENTATION (OUTWARD ALONG AXES) AS SHOWN AT LEFT
- B. TRANSMIT FIRST SITE SURVEY CMD

- FLIP/CAL SEQUENCE
- C. FLIP/CAL CYCLE CALIBRATES ALL SENSORS, THEN FLIPS IN SEQUENCE (+180°)
 - D. X-AXIS SENSOR IN X-Y PLANE (X→Y→-X)
 - E. Y-AXIS SENSOR IN X-Y PLANE (Y→X→-Y)
 - F. Z-AXIS SENSOR IN Z-X PLANE (Z→X→-Z)
 - G. ALL SENSORS ARE CALIBRATED AGAIN IN THE NEW POSITION
- SET 90° STOP

NEXT ROTATIONS
& SURVEY POSITION

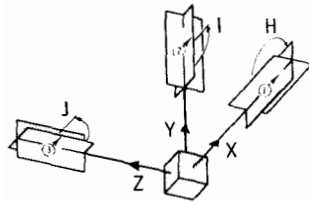

- H. X-AXIS SENSOR FLIPS -180° (-X→Y→X)
- I. Y-AXIS SENSOR FLIPS -90°, ENGAGING STOP (-Y→X)
- J. Z-AXIS SENSOR FLIPS -90°, ENGAGING STOP (-Z→X)
- K. SENSORS ARE ALL ORIENTED IN X-DIRECTION (FOR X-AXIS SITE SURVEY) AS SHOWN AT RIGHT

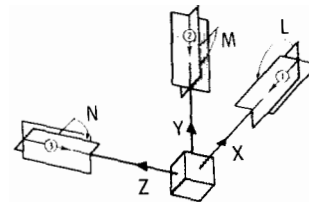

FINAL ROTATIONS
& END POSITIONS

- L. AFTER COLLECTING X-AXIS SURVEY DATA FOR ≈150 SEC, X-AXIS SENSOR FLIPS -180° (X→Y→-X)

- M. Y-AXIS SENSOR FLIPS +90°, RELEASING STOP (X→-Y)
- N. Z-AXIS SENSOR FLIPS +90°, RELEASING STOP (X→-Z)
- O. SENSORS ARE NOW IN SCIENTIFIC ORIENTATION (REVERSED) AS SHOWN AT LEFT AND WILL REMAIN THERE UNTIL NEXT GROUND CMD IS TRANSMITTED

THIS COMPLETES SUBSEQUENCE 1 OF SITE SURVEY

LSM Y-AXIS SURVEY

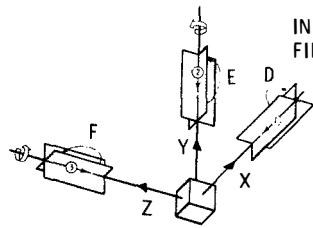

INITIAL POSITION & FIRST ROTATIONS

- A. SENSORS INITIALLY IN SCIENTIFIC ORIENTATION (INWARD ALONG AXES) AS SHOWN AT LEFT
- B. TRANSMIT SECOND SITE SURVEY CMD

FLIP/CAL SEQUENCE

- C. FLIP/CAL CYCLE CALIBRATES ALL SENSORS, THEN FLIPS IN SEQUENCE (-180°)
- D. X-AXIS SENSOR IN X-Y PLANE (-X-Y-X)
- E. Y-AXIS SENSOR (-Y-X/Z-Y) INC 90° GIMBAL ROTATION
- F. Z-AXIS SENSOR (-Z-X/Y-Z) INC 90° GIMBAL ROTATION
- G. ALL SENSORS ARE CALIBRATED AGAIN IN THE NEW POSITION

NEXT ROTATIONS & SURVEY POSITION

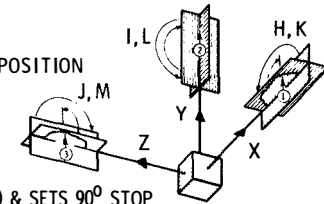

- H. X-AXIS SENSOR FLIPS +180° (X-Y--X) & SETS 90° STOP
- I. Y-AXIS SENSOR FLIPS +180° (Y-Z--Y)
- J. Z-AXIS SENSOR FLIPS +180° (Z-Y--Z) & SETS 90° STOP
- K. X-AXIS SENSOR FLIPS -90°, ENGAGING STOP (-X-Y)
- L. Y-AXIS SENSOR FLIPS -180° (-Y-Z-Y)
- M. Z-AXIS SENSOR FLIPS -90°, ENGAGING STOP (-Z-Y)
- N. SENSORS ARE ALL ORIENTED IN Y-DIRECTION (FOR Y-AXIS SITE SURVEY) AS SHOWN AT RIGHT

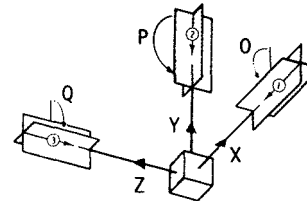

FINAL ROTATIONS & END POSITION

- O. AFTER COLLECTING Y-AXIS SITE SURVEY DATA FOR ≈150 SEC, X-AXIS SENSOR FLIPS +90°, RELEASING STOP (Y--X)
- P. Y-AXIS SENSOR FLIPS +180° (Y-Z--Y)
- Q. Z-AXIS SENSOR FLIPS +90°, PERMANENTLY RELEASING STOP (Y--Z)
- R. SENSORS ARE NOW IN SCIENTIFIC ORIENTATION (REVERSED) AS SHOWN AT LEFT & WILL REMAIN THERE UNTIL NEXT GROUND CMD IS TRANSMITTED

THIS COMPLETES SUBSEQUENCE 2 OF SITE SURVEY

LSM Z-AXIS SURVEY

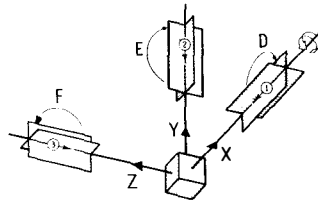

INITIAL POSITION & FIRST ROTATIONS

- A. SENSORS INITIALLY IN SCIENTIFIC ORIENTATION (INWARD ALONG AXES) AS SHOWN AT LEFT
- B. TRANSMIT THIRD SITE SURVEY CMD

- FLIP/CAL SEQUENCE
- C. FLIP/CAL CYCLE CALIBRATES ALL SENSORS, THEN FLIPS IN SEQUENCE (-180°)
 - D. X-AXIS SENSOR (-X-Y/Z-X) INC 90° GIMBAL ROTATION
 - E. Y-AXIS SENSOR IN Y-Z PLANE (-Y-Z-Y)
 - F. Z-AXIS SENSOR IN Y-Z PLANE (-Z-Y-Z)
 - G. ALL SENSORS ARE CALIBRATED AGAIN IN THE NEW POSITION

NEXT ROTATIONS & SURVEY POSITION

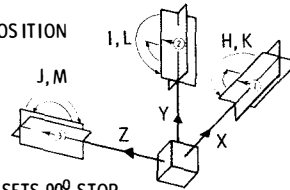

- H. X-AXIS SENSOR FLIPS +180° (X-Z-Z) & SETS 90° STOP
- I. Y-AXIS SENSOR FLIPS +180° (Y-Z--Y) & SETS 90° STOP
- J. Z-AXIS SENSOR FLIPS +180° (Z-Y--Z)
- K. X-AXIS SENSOR FLIPS -90°, ENGAGING STOP (-X-Z)
- L. Y-AXIS SENSOR FLIPS -90°, ENGAGING STOP (-Y-Z)
- M. Z-AXIS SENSOR FLIPS -180° (-Z-Y-Z)
- N. SENSORS ARE ALL ORIENTED IN Z-DIRECTION (FOR Z-AXIS SITE SURVEY) AS SHOWN AT RIGHT

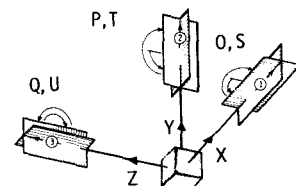

FINAL ROTATIONS & END POSITIONS

- V. FINAL CALIBRATION OF ALL SENSORS IN NEW POSITION
 - SENSORS ARE IN SCIENTIFIC ORIENTATION AS SHOWN AT LEFT & WILL NOT PERFORM ANY MORE 90° FLIPS OR GIMBAL ROTATIONS (FLIP/CAL BY CMD OR TIMER)
 - ALL POWER TO SITE SURVEY SEQUENCER IS CUT OFF (COMPLETION OF SUBSEQUENCE 3 & SITE SURVEY)

- O. AFTER COLLECTING Z-AXIS SURVEY DATA FOR ≈150 SEC, X-AXIS SENSOR FLIPS -90°, PERMANENTLY RELEASING STOP (Z-X)
- P. Y-AXIS SENSOR FLIPS -90°, PERMANENTLY RELEASING STOP (Z-Y)
- Q. Z-AXIS SENSOR FLIPS -180° (Z-Y-Z)
- R. FLIP/CAL CYCLE CALIBRATES ALL SENSORS, THEN FLIPS IN SEQUENCE (-180°)
- S. X-AXIS SENSOR IN X-Z PLANE (-X-Z-X)
- T. Y-AXIS SENSOR IN Y-Z PLANE (-Z-Y-Z)
- U. Z-AXIS SENSOR IN Y-Z PLANE (-Z-Y-Z)

LSM FAIL-SAFE PROVISIONS

- IF FLIP MECHANISM OR INDICATOR MALFUNCTIONS, 10-SEC TIMER TURNS OFF MOTOR AND ADVANCES SEQUENCE TO NEXT STEP (PARTIAL FAILURE, AT WORST)
- DETENT SYSTEM DISENGAGES 90° STOP CAM AND GIMBAL RELEASE AT END OF SITE SURVEY (NOT USED THEREAFTER)

LSM POWER CONVERTER

- CONVERTS ALSEP +29V INPUT TO 8 REGULATED OUTPUTS ($\pm 5V$, $\pm 7V$, $\pm 10V$, $\pm 15V$)
- PROVIDE SWITCHING TO REMOVE POWER FROM VARIOUS PORTIONS OF LSM ELECTRONICS WHEN THEY ARE ON INACTIVE STANDBY
- A POWER FILTER MODULE IS INCLUDED IN THE SENSOR COMMON ELECTRONICS FOR CERTAIN PRECISION REQUIREMENTS

LSM POWER PROFILE

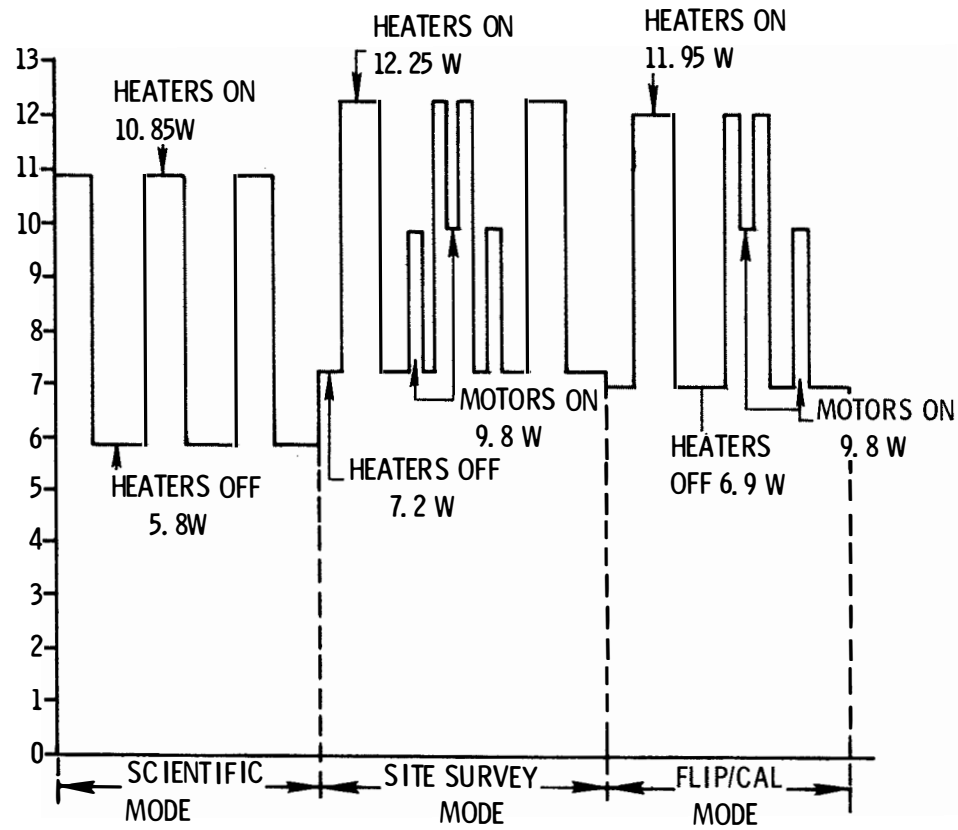

LSM ENGINEERING ELECTRONICS

- TEMPERATURE CONTROL CMD & FUNCTION
- MOTOR DRIVERS
- FLIP & GIMBAL POSITION DETECTORS
- LEVEL SENSOR
- ENG SEQUENCER

LSM TEMPERATURE CONTROL

SENSORS

- SENSORS HOUSED IN FIBERGLAS STRUCTURAL JACKET
- WRAPPED WITH INSULATION EXCEPT UPPER (HORIZONTAL) SURFACE
- UPPER SURFACE IS HEAT RADIATOR
- 3 TEMP SENSORS (X, Y, & Z) FOR TM: X OR Y SELECTED (BY CMD) FOR HEATER CONTROL
- INDIVIDUAL 1-WATT HEATERS

EGFU

- 2-SECTION PACKAGE (TOP & BOTTOM) WITH ALUMINUM BASE PLATE IN MIDDLE
- ELECTRO-MECHANICAL ON TOP & ELECTRONICS ON BOTTOM MOUNTED ON PLATE (CONDUCTIVE THERMAL TRANSFER)
- PLATE COUPLED TO PRA (THERMAL RADIATORS) ON 2 SIDES OF EGFU (N&S)
- TOP OF EGFU HAS FIBERGLAS COVER
- ALUMINIZED KAPTON INSULATION OVER ALL SURFACES EXCEPT RADIATORS
- 2 TEMP SENSORS IN TM
- 2.3-WATT HEATER

OPERATING RANGE: -30°C TO +65°C
NO STBY (SURVIVAL) POWER CONNECTION

OCTAL CMD NUMBER

134 LSM T CTL XYO

THIS IS A 3-STATE COMMAND (X, Y, OFF) WHICH IS USED TO SELECT ONE OF TWO TEMP SENSORS FOR HEATER CONTROL OR TO DEACTIVATE THE HEATER POWER. ALL 4 HEATERS ARE CONTROLLED IN PARALLEL BY EITHER OF TWO TEMP SENSORS (ONE IN THE SENSOR X ASSEMBLY & ONE IN THE SENSOR Y ASSEMBLY). LSM ACTIVATION PRESETS TO THE X STATE. REPEATED TRANSMISSION OF THIS CMD ADVANCES THE STATE SEQUENTIALLY THROUGH Y, OFF, X, ETC. IN THE OFF STATE, ALL POWER TO ALL 4 HEATERS IS REMOVED.

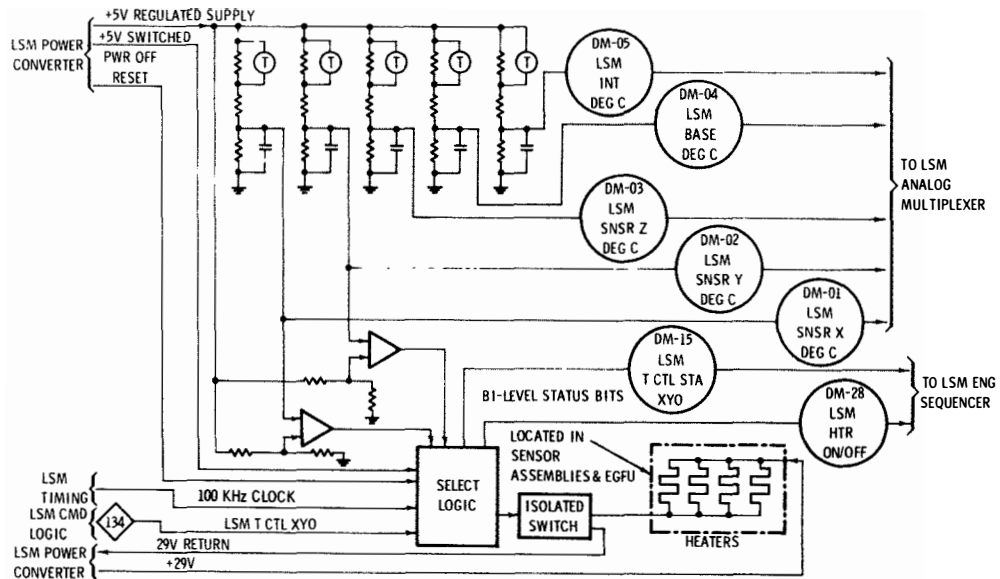

LSM MOTOR LOGIC AND DRIVERS

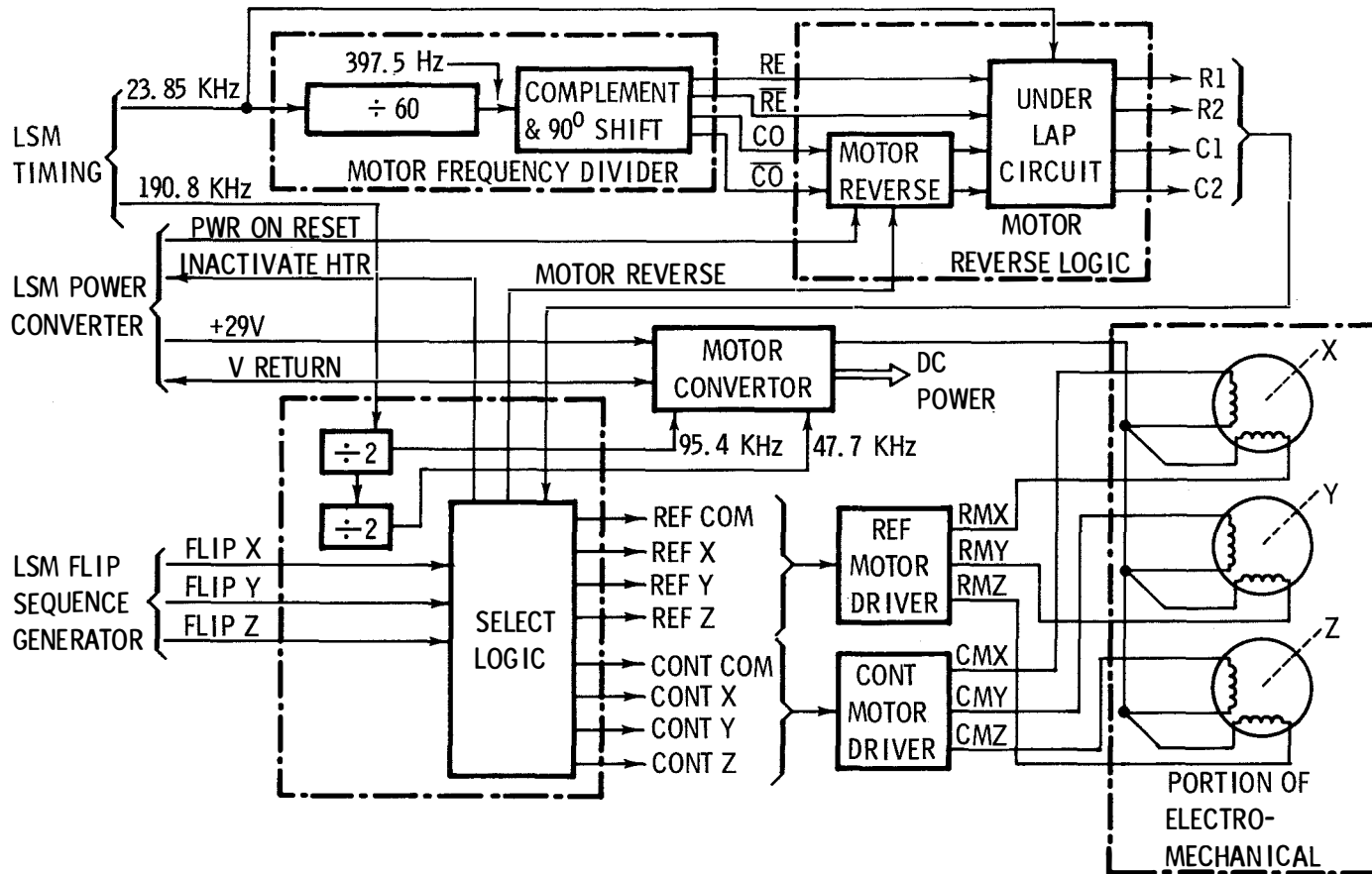

LSM FLIP POSITION DETECTORS

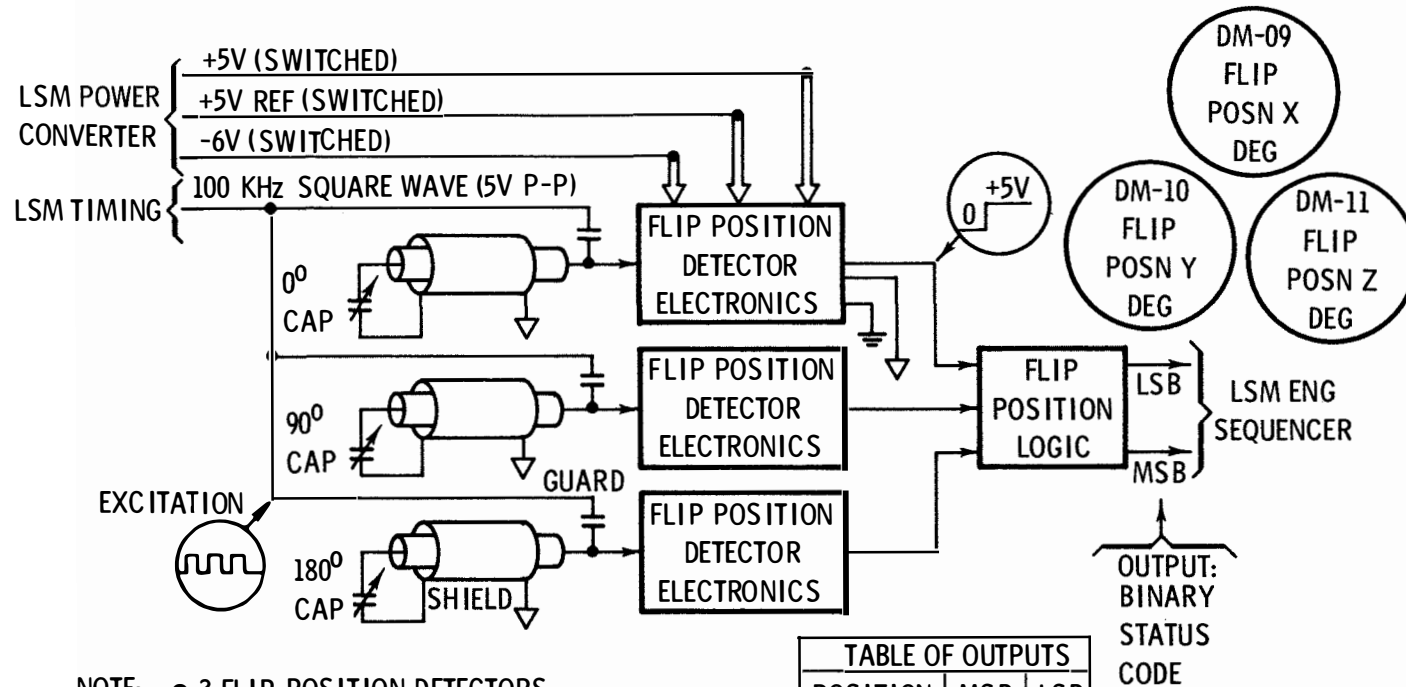

- NOTE:
- 3 FLIP POSITION DETECTORS (0° , 90° , 180°) SHOWN FOR ONE LSM SENSOR (EXAMPLE: X, IN TABLE)
 - SIMILAR FOR LSM SENSORS Y & Z (TOTAL 9 DETECTORS)

TABLE OF OUTPUTS		
POSITION	MSB	LSB
X = 0°	0	1
X = 90°	1	0
X = 180°	1	1
NEITHER	0	0

OUTPUT:
BINARY
STATUS
CODE

LSM GIMBAL POSITION INDICATORS

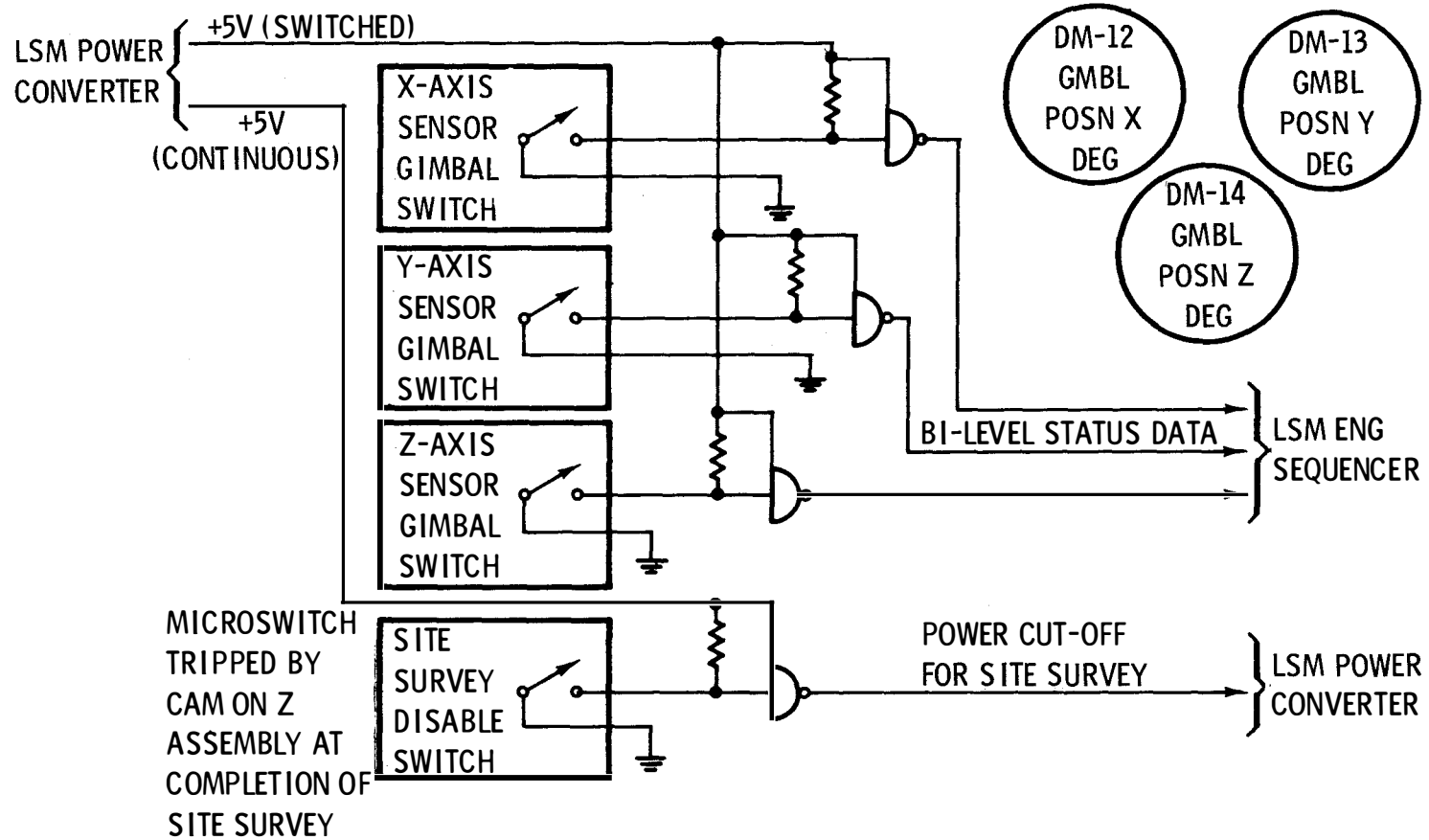

LSM LEVEL SENSOR

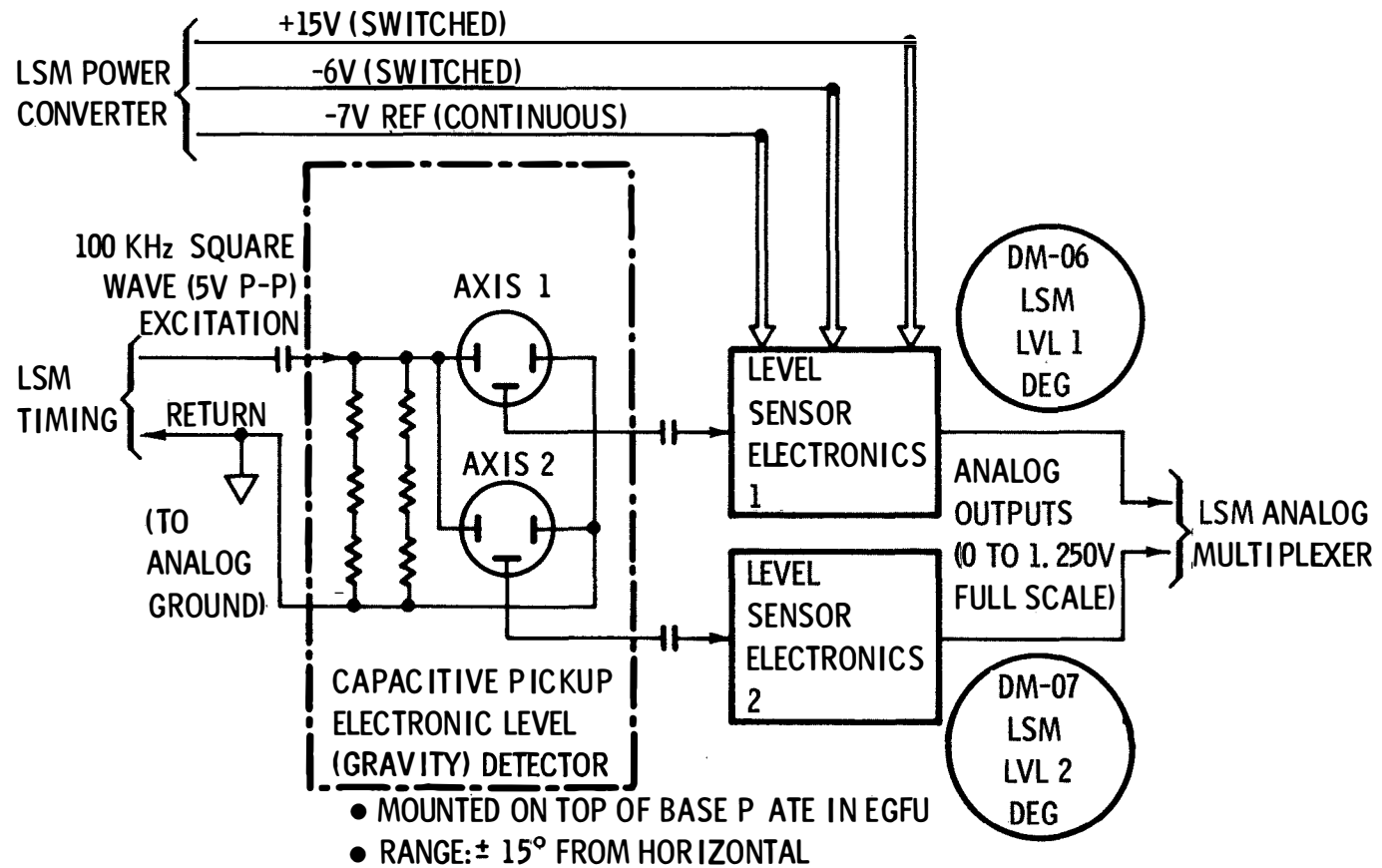

LSM ENG SEQUENCER

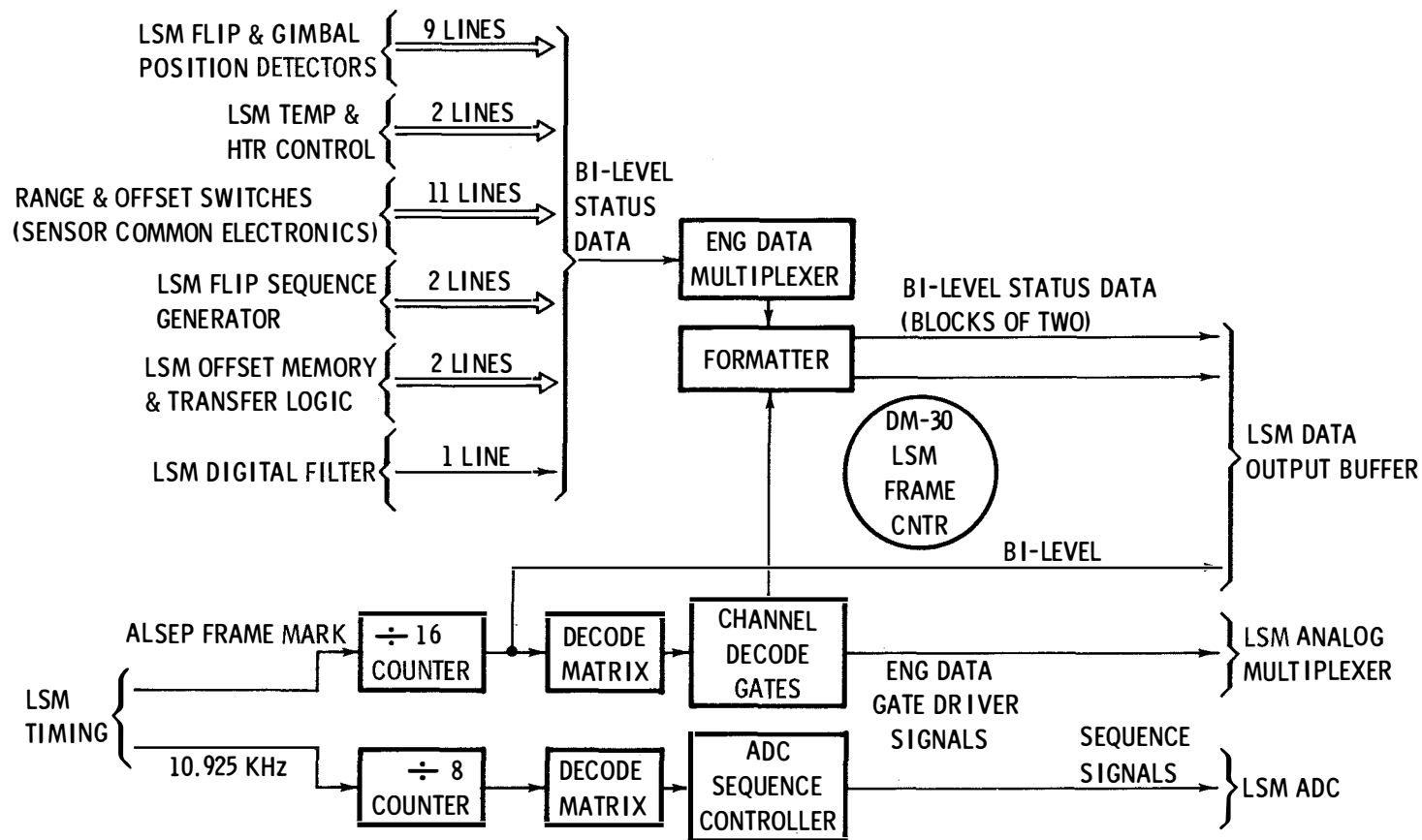

JAN 68 5178.10.30

LSM DATA HANDLING

SCIENTIFIC

- OUTPUTS OF 3 SENSOR ELECTRONICS CHANNELS (PREFILTERED) ARE SAMPLED, BY SAMPLE & HOLD CIRCUIT, WITHIN 125 μ SEC OF EACH OTHER AT THE DIGITAL FILTER SAMPLING RATE
- MULTIPLEXED SEQUENTIALLY INTO THE 10-BIT ADC
- CONVERTED INTO 10-BIT BINARY (POLARITY & 9-BIT MAGNITUDE) & STORED IN DIGITAL FILTER MEMORY
- DIGITAL FILTER (COMPUTER):
 - REDUCES (TO ACCEPTABLE LEVEL) ALIASING ERROR INTRODUCED BY SAMPLING RATE
 - USES STATE VARIABLES (FILTERED OUTPUT OF EACH CHANNEL AT A REAL-TIME INSTANT) TO PERFORM FILTER COMPUTATIONS
 - STORED IN CORE MEMORY WHEN NOT IN USE
- 3 CHANNELS (X, Y, & Z) TIME SHARE THE ARITHMETIC UNIT, DATA BUS, & DATA CONTROL UNIT
- STATE VARIABLES ARE SHIFTED TO THE OUTPUT DATA BUFFER

- FILTER MAY BE BYPASSED BY GROUND CMD 132 (IN CASE OF FILTER FAILURE)
- WITHOUT DIGITAL FILTER, ALIASING ERROR IS INCREASED

ENGINEERING

- 8 ANALOG ENGINEERING DATA PARAMETERS
- 27 BI-LEVEL STATUS SIGNALS
- ANALOG IS MULTIPLEXED TO USE SAME ADC AS SCIENTIFIC DATA
- 10-BIT OUTPUT (NO POLARITY) TRUNCATED TO 7 BITS (0.5% RESOLUTION)
- BYPASSES DIGITAL FILTER & IS INTEGRATED IN OUTPUT DATA BUFFER (16 10-BIT WORDS):
 - TWO 8-WORD SEQUENCES OF 7-BIT ANALOG OUTPUT
 - 16 2-BIT STATUS SIGNALS (INC 5 FILLER BITS)
 - ONE BIT (LSM FRAME CNTR) TO FLAG START OF 16-WORD SEQUENCE
- INSERTED INTO DATA STREAM AS EVERY 7TH LSM WORD

- CONTENTS OF OUTPUT DATA BUFFER READOUT SEQUENTIALLY TO THE ALSEP DSS UPON RECEIPT OF DATA DEMAND PULSE
- NOTE THAT ALSEP READOUT OF LSM SCIENTIFIC DATA IS STAGGERED (IN TIME) BUT EACH SET OF 3 (X, Y, & Z) SAMPLES IS OBTAINED \approx SIMULTANEOUSLY & SUCCESSIVE SAMPLES ARE AT \approx EQUAL TIME INTERVALS

LSM FILTER BYPASS COMMAND

OCTAL CMD NUMBER

132 LSM FILT IN/OUT

THIS IS A 2-STATE CMD (IN/OUT). LSM ACTIVATION PRESETS THE DIGITAL FILTER IN. TRANSMISSION OF THIS CMD CAUSES A MAJOR PORTION OF THE FILTER TO BE BYPASSED. REPEATED TRANSMISSION OF THIS CMD CAUSES THE FILTER TO BE IN, OUT, IN, ETC.

LSM DATA FORMAT

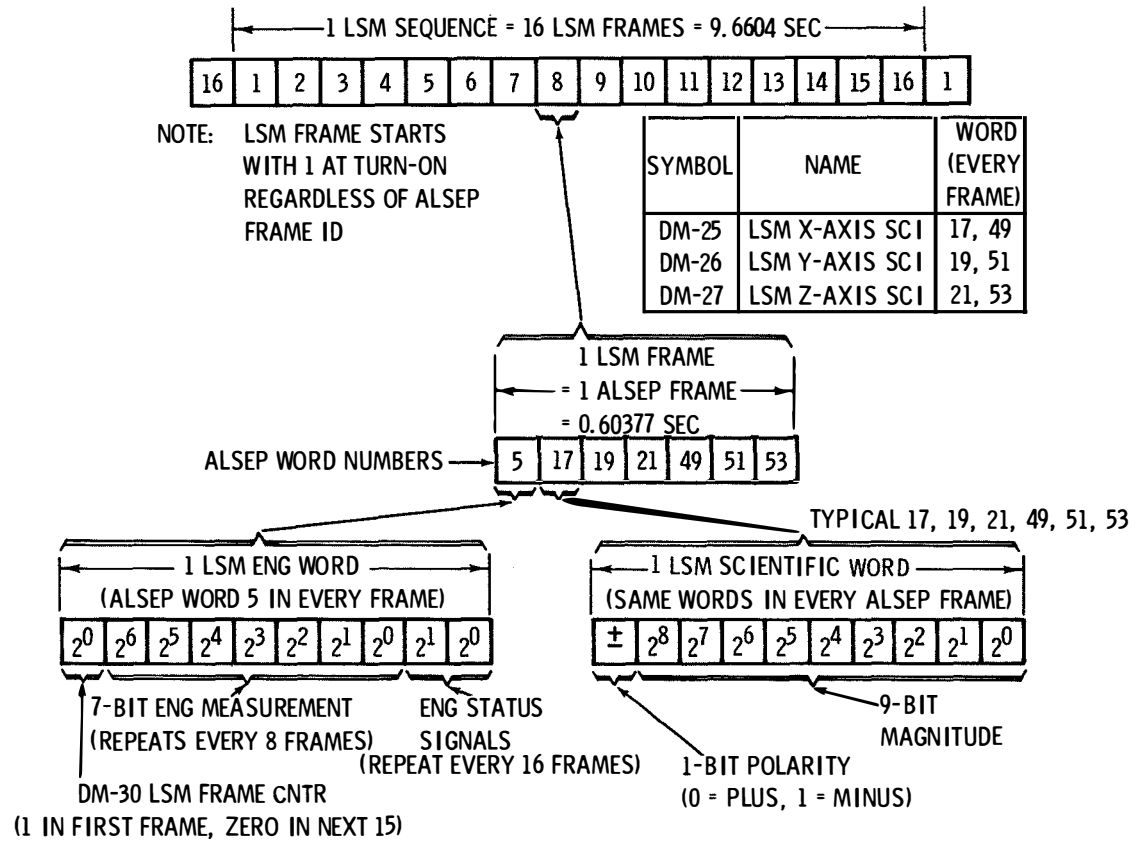

LSM ENGINEERING DATA

ANALOG MEASUREMENTS

SYMBOL	NAME	LSM FRAME NUMBER	REMARKS
DM-01	LSM SNSR X DEG C	1, 9	● 7-BIT DATA IN ALSEP WORD 5
DM-02	LSM SNSR Y DEG C	2, 10	
DM-03	LSM SNSR Z DEG C	3, 11	
DM-04	LSM BASE DEG C	4, 12	● LSM HAS NO ANALOG DATA INPUT TO ALSEP ADC (WORD 33)
DM-05	LSM INT DEG C	5, 13	
DM-06	LSM LVL 1 DEG	6, 14	
DM-07	LSM LVL 2 DEG	7, 15	
DM-08	LSM 5V SUPPLY	8, 16	

ENGINEERING STATUS SIGNALS

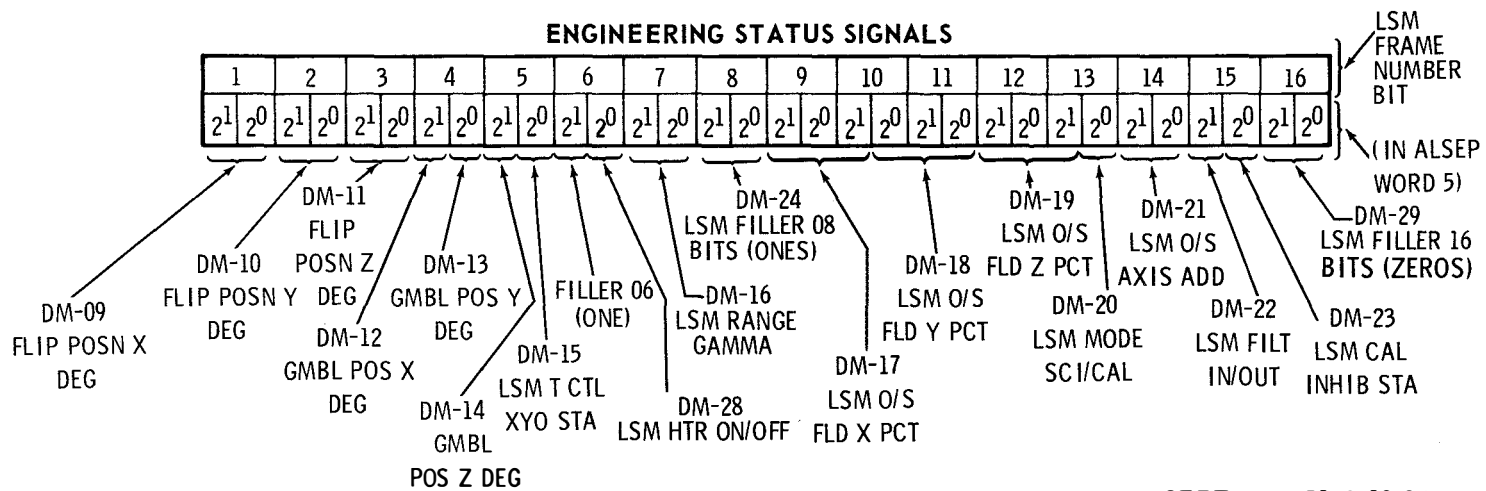

LSM DEPLOYMENT

STOWED CONFIGURATION

- FOLDED BOOMS & LEGS SECURED BY 2-PIECE HORSECOLLAR, ATTACHED TO FORWARD MOUNTING BRACKET BY BOYD BOLTS
- AFT END (EGFU) SEATED ON 2 TITANIUM PINS PROJECTING UP FROM PYLON
- EGFU LOCKED BY SLIDE PLATE (LANYARD ACTUATED) ENGAGING LOCKING SURFACES OF PINS

REMOVAL

- USE UHT TO RELEASE FORWARD BOYD BOLTS
- PULL HANDLE ON TOP OF HORSECOLLAR TO DISENGAGE BRACES AND DISCARD UPPER HALF OF HORSECOLLAR AND BRACES
- PULL HANDLE ON TOP OF EGFU TO RELEASE SLIDE PLATE FROM PINS AND LIFT LSM STRAIGHT UP TO REMOVE FROM SUNSHIELD
- GRASP HANDLE LOOPED BETWEEN BOOM HINGES. REMOVE LOWER HALF OF HORSECOLLAR AND LOWER LSM TO SURFACE

FINAL PLACEMENT

- CARRY 50 FT TO EMPLACEMENT SITE
- DEPLOY LUNAR SUPPORT LEGS
- LOWER TO SURFACE (STRIPED LEG EAST)
- UNFOLD BOOMS (DISCARD HANDLE)
- REMOVE PRA COVERS
- ADJUST LEVEL (BUBBLE ON TOP OF EGFU) USING UHT TO ROTATE SCREW IN EACH LEG AT JOINT TO EGFU
- ALIGN E-W USING SHADOWGRAPH (MOUNTED ON TOP OF EGFU)
- MAKE FINAL SHADOWGRAPH READOUT

APR 69 5178.10.35

LSM EMPLACEMENT CRITERIA

PARAMETER	REQUIREMENT	PRIORITY	INDICATOR	COMMENTS
DISTANCE FROM SUBPACKAGE 1	50 ±5 FT	2	55 FT CABLE	IN QUADRANT OPPOSITE RTG TO MINIMIZE MAGNETIC EFFECTS
DIRECTION FROM SUBPACKAGE 1	OPPOSITE LM ±20°	2	EYEBALL	MINIMIZE MAGNETIC CONTAMINATION
SITE SELECTION	AVOID RUBBLE	3	EYEBALL	FOR MAXIMUM STABILITY
LEVEL, WRT INDICATOR	+ 5° OF HORIZ (ACCEPTABLE) + 3° OF HORIZ (GOAL)	1	BUBBLE LEVEL ON EGFU	TM OF INTERNAL LEVEL SENSOR
ALIGN, WRT SHADOW	± 3° OF E-W	1	SHADOWGRAPH	COLOR-CODED LEG POINTS E°
READOUT OF ALIGNMENT, WRT SHADOW	± 1° OF E-W	1	SHADOWGRAPH	NEEDED FOR SCIENTIFIC DATA INTERPRETATION; THERMAL LESS CRITICAL**
EXPERIMENT INTERRELATION	MUST BE AT LEAST 80 FT FROM SIDE AND PREFERABLY 100 FT			
SPECIAL REQUIREMENTS	*COULD BE ROTATED 180° AND MEET THERMAL CRITERIA; HOWEVER, SHADOWGRAPH IS NOT REVERSIBLE **RADIATORS ON ELECTRONICS REQUIRE E-W ALIGNMENT±3°.			

LSM LEVELING AND ALIGNMENT

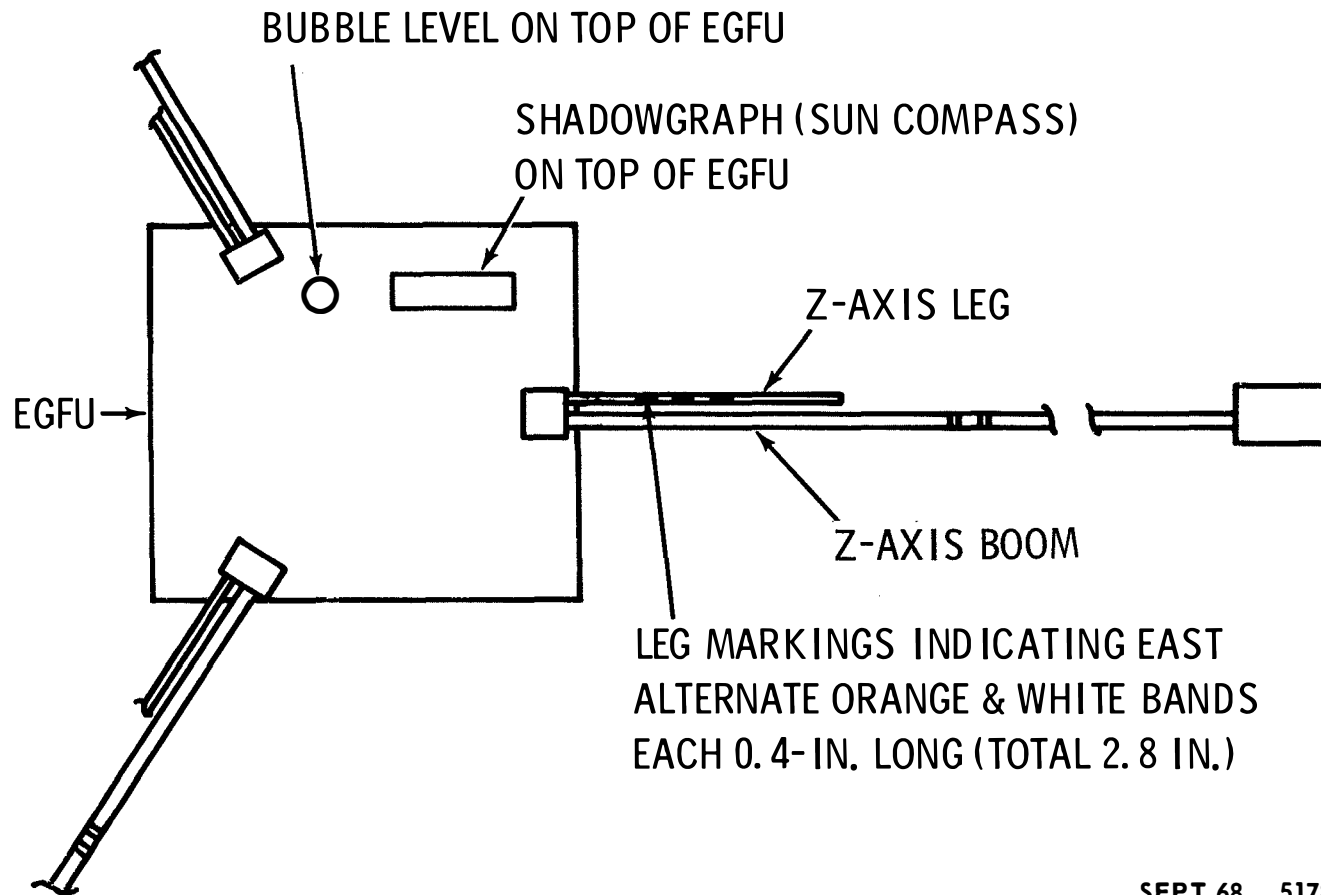

SEPT 68 5178.10.37

SOLAR WIND SPECTROMETER

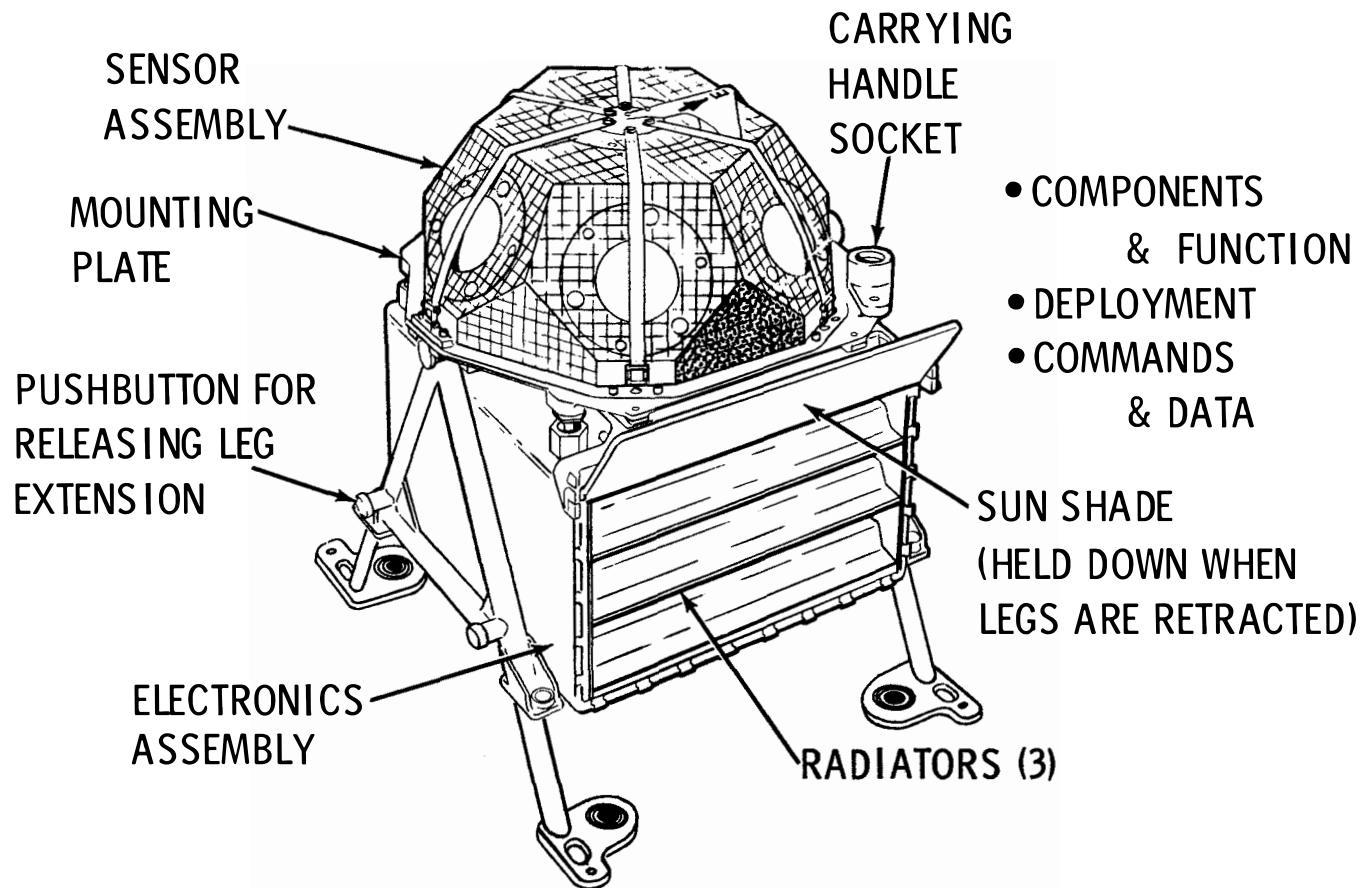

APR 69 5178.11.1

SWS SIZE AND WEIGHT

EARTH WT, LB = 12.25

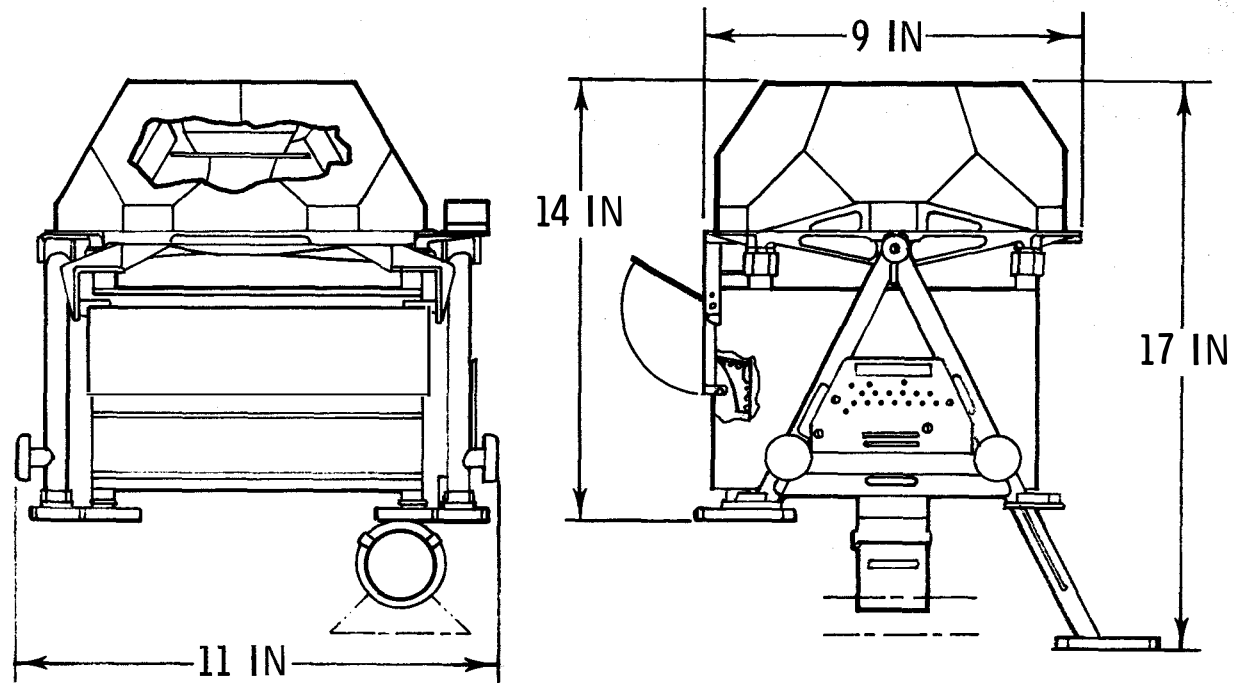

OCT 68 5178.11.2

SWS MEASUREMENT CAPABILITY

ENERGY RANGE:

ELECTRONS - 6 to 1330 ELECTRON VOLTS
POSITIVE IONS - 18 to 9780 ELECTRON VOLTS } TWO RANGES

FLUX DENSITY RANGE:

10^6 to 10^{10} PARTICLES PER CM^2 PER SEC

ENERGY RESOLUTION:

ELECTRONS - FACTOR OF 2
POSITIVE IONS - FACTOR OF $\sqrt{2}$

FLUX RESOLUTION:

3.7 % OF TRUE FLUX VALUE

DIRECTION:

INCIDENCE ANGLES $\pm 15^\circ$ FOR COLLIMATED FLUX

MODULATING FARADAY CUP

- MODULATOR CIRCUIT APPLIES 2 KHz SQUARE WAVE TO SENSOR
- 2 KHz SUPERIMPOSED ON DC (PEAK-TO-PEAK)
 - 1/6 OF DC LEVEL FOR POSITIVE DC
 - 1/3 OF DC LEVEL FOR NEGATIVE DC
- DC LEVEL STEPS (STAIRCASE FASHION) THROUGH CONTINUOUS, SUCCESSIVE VALUES
 - 14 TIMES WITH $X\sqrt{2}$ SPACING FOR POSITIVE DC
 - 7 TIMES WITH $X 2$ SPACING FOR NEGATIVE DC

ADVANTAGE

STRAY PARTICLE FLUXES, SUCH AS PHOTOELECTRONS PRODUCED INSIDE THE SENSOR, ARE NOT CHANGED BY THE MODULATION POTENTIAL; THEREFORE, THEY ARE NOT INCLUDED WITHIN THE MEASUREMENTS.

SWS DUST COVERS

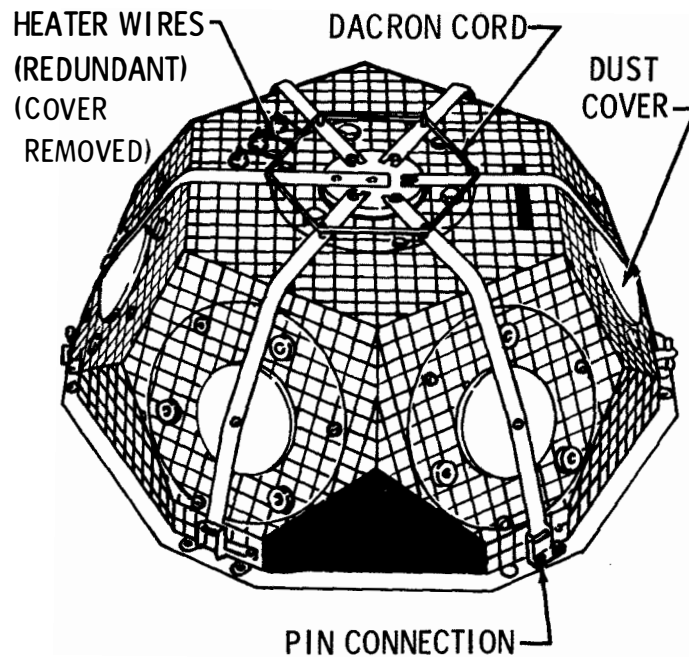

- HEATER WIRES BURN RETAINING CORD TO RELEASE COVERS
- INITIATED BY GROUND COMMAND
- REQUIRED BURN TIME, 1.5 SEC
- POWER APPLIED 4 ± 2 SEC

APR 69 5178.11.5

SWS FUNCTIONAL DIAGRAM

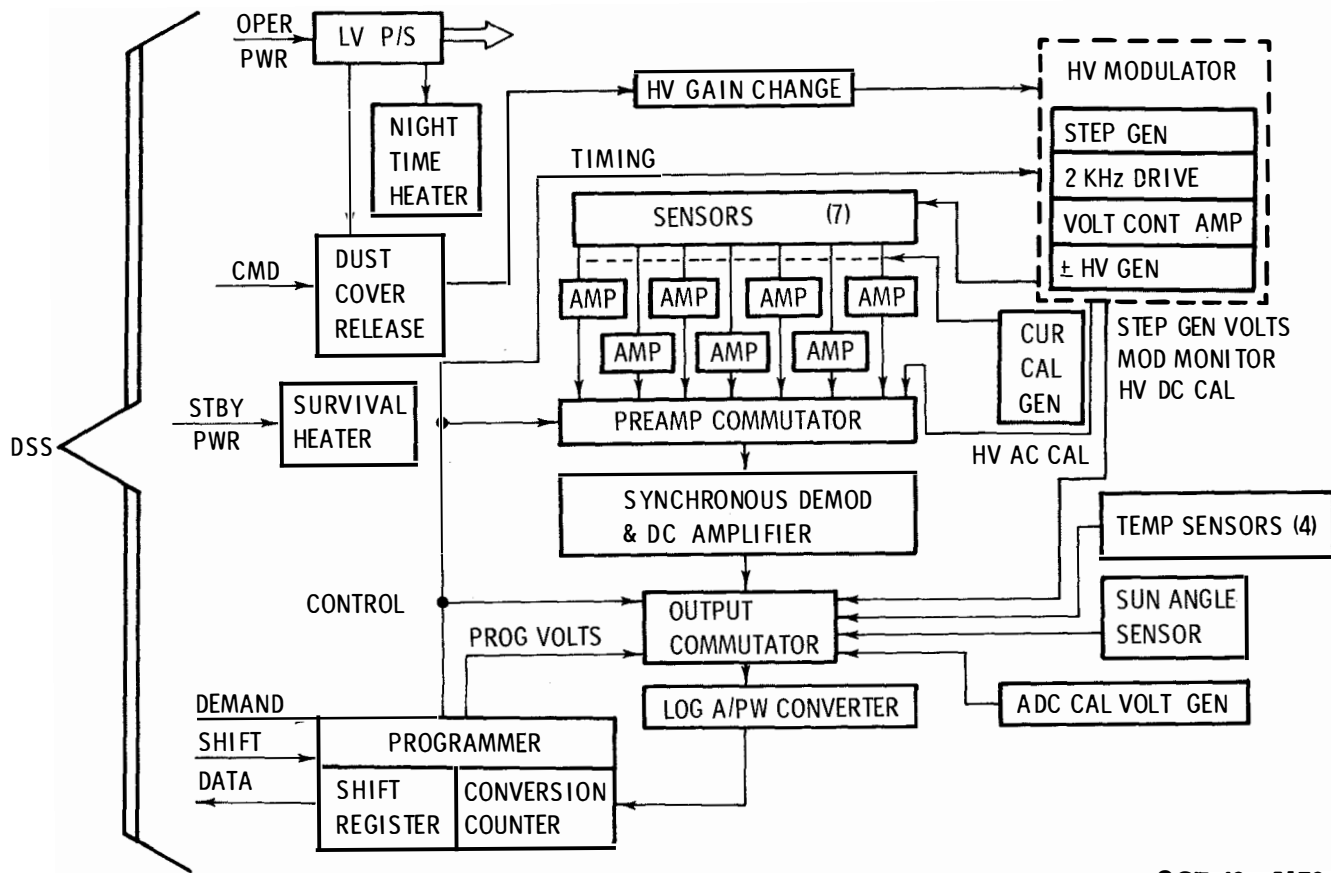

OCT 68 5178.11.6

SWS ELECTRONIC MODULES

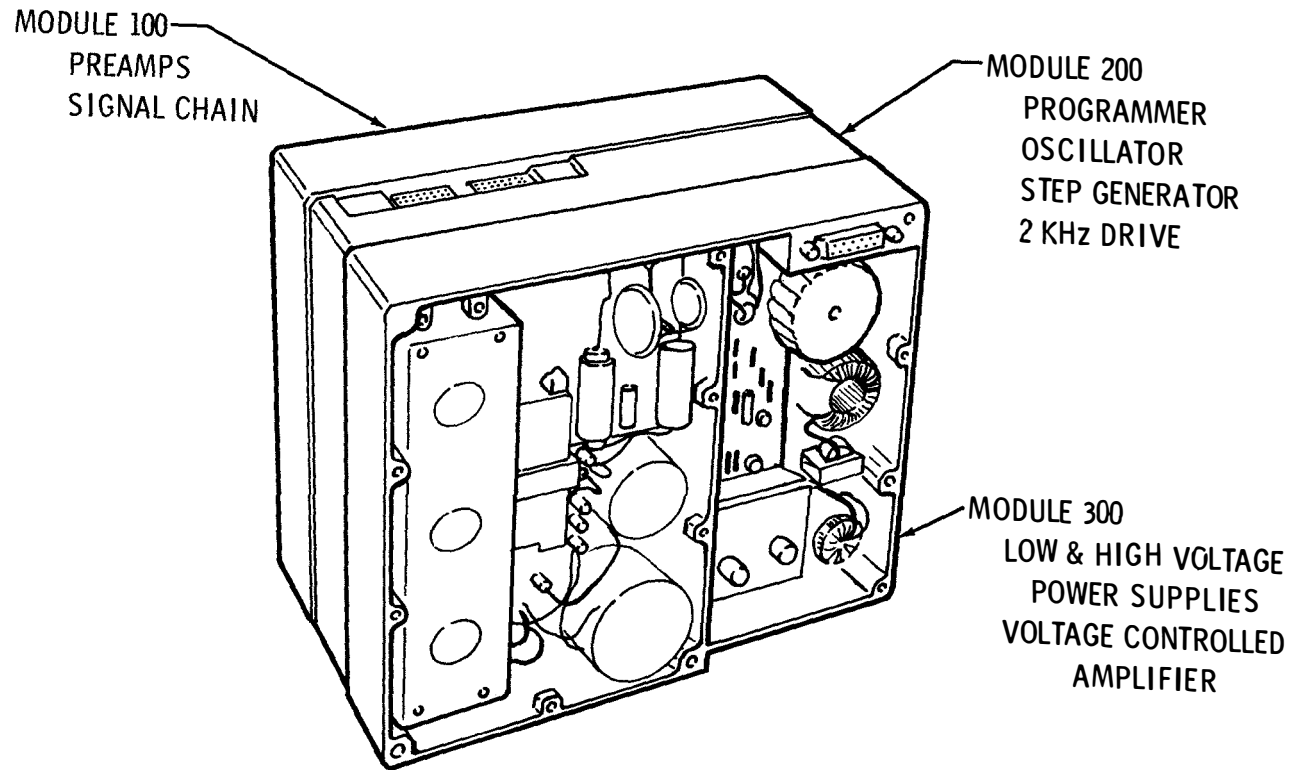

DEC 67 5178.11.7

SWS VERIFICATION FEATURES

CALIBRATION TYPE	NUMBER OF WORDS	DISTRIBUTION	REPETITION RATE *
2 KHz CURRENT PULSES $\pm 2\%$ TO PREAMPS	32	4 VALUES (INC 0) INTO EACH CHAIN & 7 COMBINED	112.3 SEC
CAL VOLTAGES $\pm 2\%$ TO OUTPUT COMMUTATOR	8	5 VALUES PLUS 3 REPEATS	56.1 SEC
READOUT OF AC & DC HIGH VOLTAGES	42	14 EACH FOR + DC 7 EACH FOR - DC	449.2 SEC

* AT NORMAL ALSEP DATA RATE, COMPLETE SWS CYCLE (449.2 SEC) CONSISTS OF 16 SEQUENCES (28.065 SEC)

NOV 67 5178.11.8

SWS THERMAL CONTROL

MECHANICAL
 GOLD - PLATED FIBERGLAS HOUSING
 COVERED WITH SILK/MYLAR (ALUMINIZED)
 & COATED WITH WHITE PAINT

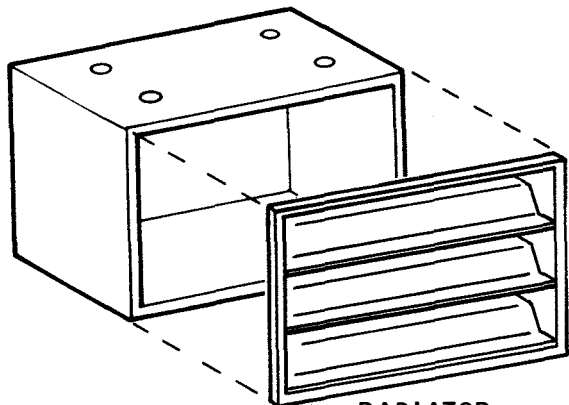

RADIATOR
 (ONE SIDE ONLY)

ELECTRICAL

UNIT	LOCATION	REMARKS
THERMISTOR (1) SENSOR	SENSOR ASSY	WINSKO MODEL 2712-4-00-2
THERMISTORS (3) SENSOR	MOD 100, 200, 300	YELLOW SPRINGS YSI 44063
THERMISTOR (1) CONTROL	MOD 300 ACTIVATES < 25° C	YELLOW SPRINGS YSI 44063
OPERATIONAL HEATERS (SERIES)	MOD 200	43-OHM DISSIPATES 1.2 W
	MOD 300	75 - OHM DISSIPATES 2.1 W
SURVIVAL (STBY) HEATERS (3 IN PARALLEL)	ONE IN EACH MODULE	680 - OHM (2) 600 - OHM (1) 4.0 W TOTAL (MAX)

- NOTES:
- NO MANUAL (COMMAND) THERMAL CONTROL
 - NO THERMOSTAT FOR SURVIVAL HEATER
 - OPERATIONAL HEATER LIMITED TO AVOID > 6.5 W TOTAL POWER

OCT 68 5178.11.9

SWS TIMING FUNCTIONS

INTERNAL

- BASIC 1024 KHz CLOCK
SUPPLIES 256, 2.0, & 0.5 KHz
TO VARIOUS USERS
- CONVERSION COUNTER OPERATES
AT 256 KHz
 - DC/DC CONVERTER OPERATES
AT 2.67 KHz (FREE RUNNING)
 - HV MODULATOR OPERATES
AT 2.0 KHz

EXTERNAL

- SHIFT PULSES & DEMAND PULSE FROM DATA
SUBSYSTEM ARE USED TO SHIFT DATA
FROM REGISTER
- THESE PULSES ARE ALSO USED TO PROGRAM
COMMUTATORS & STEP GENERATOR

ONE SEQUENCE OF SWS OPERATION CONSISTS OF 14 POSITIVE STEPS
(EACH TIME SAMPLING TOTAL + 7 INDIVIDUAL SENSORS), 16 CAL WORDS,
7 NEGATIVE STEPS (8 WORDS EACH) & 2 SEQUENCE/CYCLE COUNTER WORDS
(TOTAL 186) IN 28.065 SEC.

SWS POWER PROFILE

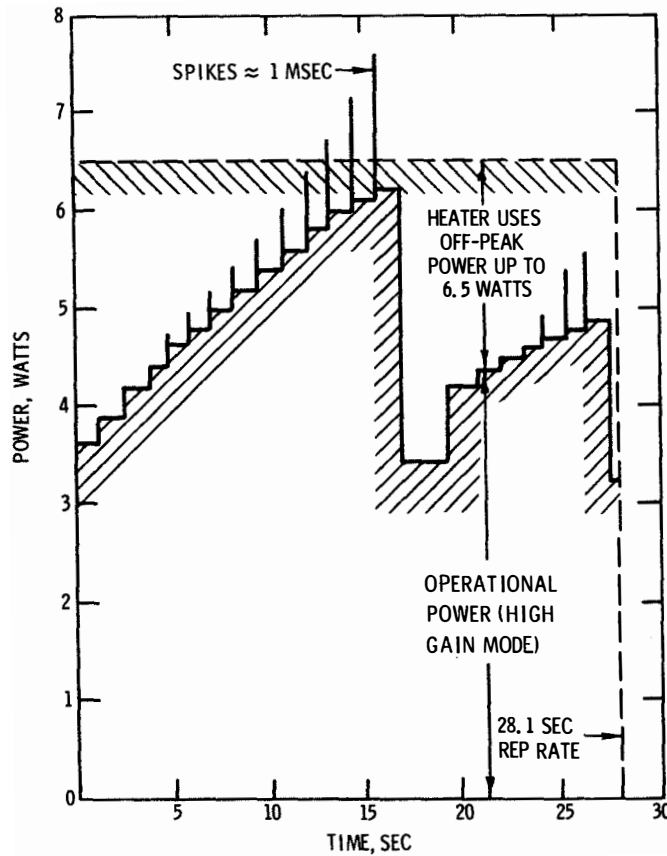

- STBY POWER: 4.0 WATTS (MAX)
- OPER POWER SHOWN EXCEPT FOR DUST COVER REMOVAL (10 WATTS FOR 4±2 SEC)
- TURN-ON TRANSIENT ≈ 10.5 WATTS FOR LESS THAN 60 MSEC

OCT 68 5178.11.11

SWS TIE-DOWN AND RELEASE

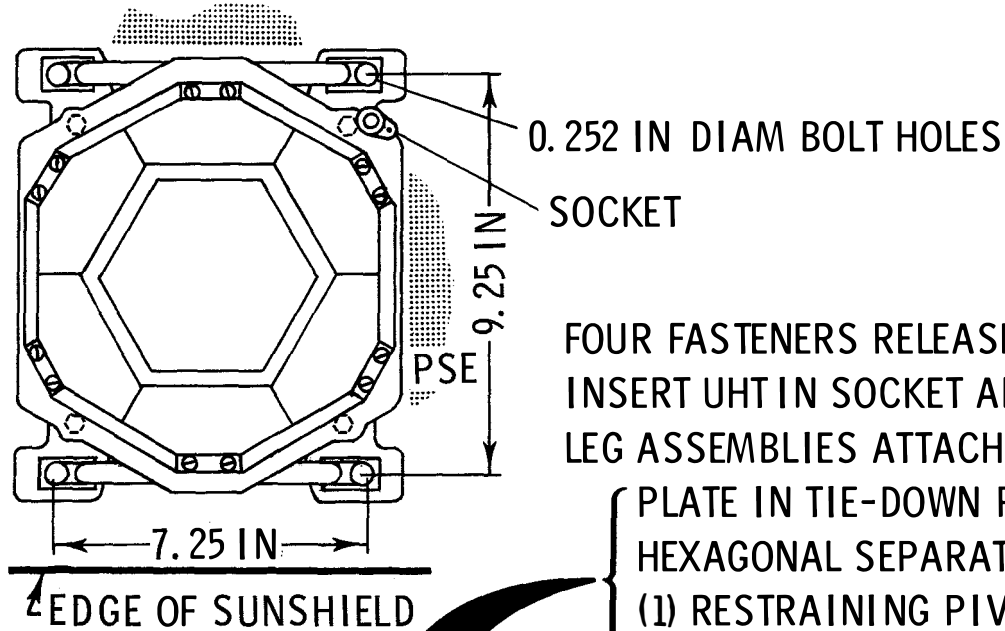

FOUR FASTENERS RELEASED BY UHT
INSERT UHT IN SOCKET AND LIFT
LEG ASSEMBLIES ATTACHED TO MOUNTING
PLATE IN TIE-DOWN POSITION COMPRESSES
HEXAGONAL SEPARATORS IN EACH CORNER:
(1) RESTRAINING PIVOTING MOTION
(2) LOCKING SUNSHADE IN STOWED POSITION

RELEASE OF TIE-DOWN
FASTENERS & LEGS ALLOWS
1/4 IN. VERTICAL SEPARATION
CABLE REEL IS STOWED UNDER SWS

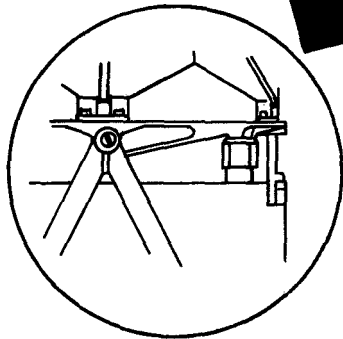

SWS EMPLACEMENT CRITERIA

PARAMETER	REQUIREMENT	PRIORITY	INDICATOR	COMMENTS
DISTANCE FROM SUBPACKAGE 1	13 + 1 ft (15 FT CABLE)	1	PACED OFF	SEE EXPERIMENT INTERRELATION
DIRECTION FROM SUBPACKAGE 1	+ 30° FROM DUE N OR S*	2	EYEBALL	+ 10° AREA OF REDUCED SENSITIVITY (OTHERS AT 60°)
SITE SELECTION	APPROX HORIZ	3	EYEBALL	AVOID THERMAL DISTURBANCES
LEVEL	+ 5 OF HORIZ	2	EYEBALL & GRAVITY	PENDULUM EFFECT ON ONE LATERAL AXIS. INTERNAL SUN SENSOR.
ALIGN, WRT SHADOW	+ 5° OF E-W	2	PAINT** AND UHT SHADOW	LOUVERED SIDE AWAY FROM RTG (THERMAL AND SCIENCE REQUIREMENT)
EXPERIMENT INTERRELATION	* NO OTHER SUBSYSTEM SHOULD SUBTEND AN ANGLE GREATER THAN 0.03 STERADIAN AT THE SOLAR WIND LOCATION AND SHOULD BE IN AN AREA OF REDUCED SENSITIVITY.			
SPECIAL REQUIREMENTS	** ARROW NOMINALLY POINTS EAST ALTHOUGH SCIENTIFIC OUTPUT DEPENDS ONLY ON KNOWING FINAL ALIGNMENT (COULD BE EAST OR WEST). FINAL ALIGNMENT BY SETTING ORANGE FACES (N-S) ON SENSOR ASSEMBLY EQUALLY IN SHADE, AND UHT SHADOW PARALLEL TO SENSOR EDGE.			

APR 69 5178.11.13

SWS ALIGNMENT MARKING

ARROW
DESIGNATING
EAST

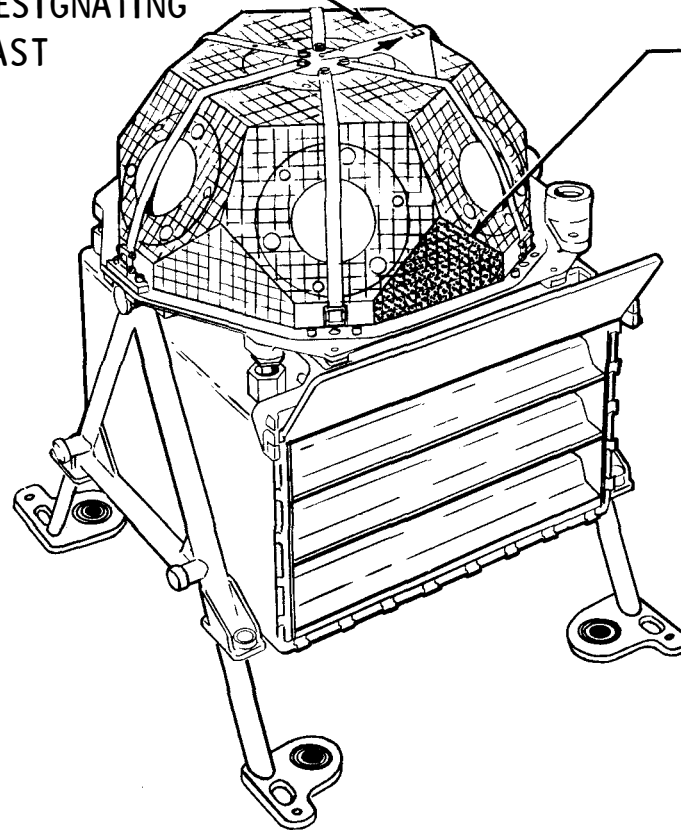

ORANGE PATTERN
2 SIDES
(N & S)

ALIGNMENT IS OBTAINED
BY ROTATING SWS UNTIL
ORANGE SURFACES HAVE
EQUAL SHADOWS AND UHT
SHADOW IS PARALLEL TO
SENSOR EDGE

APR 69 5178.11.14

SWS ALIGNMENT MECHANISM

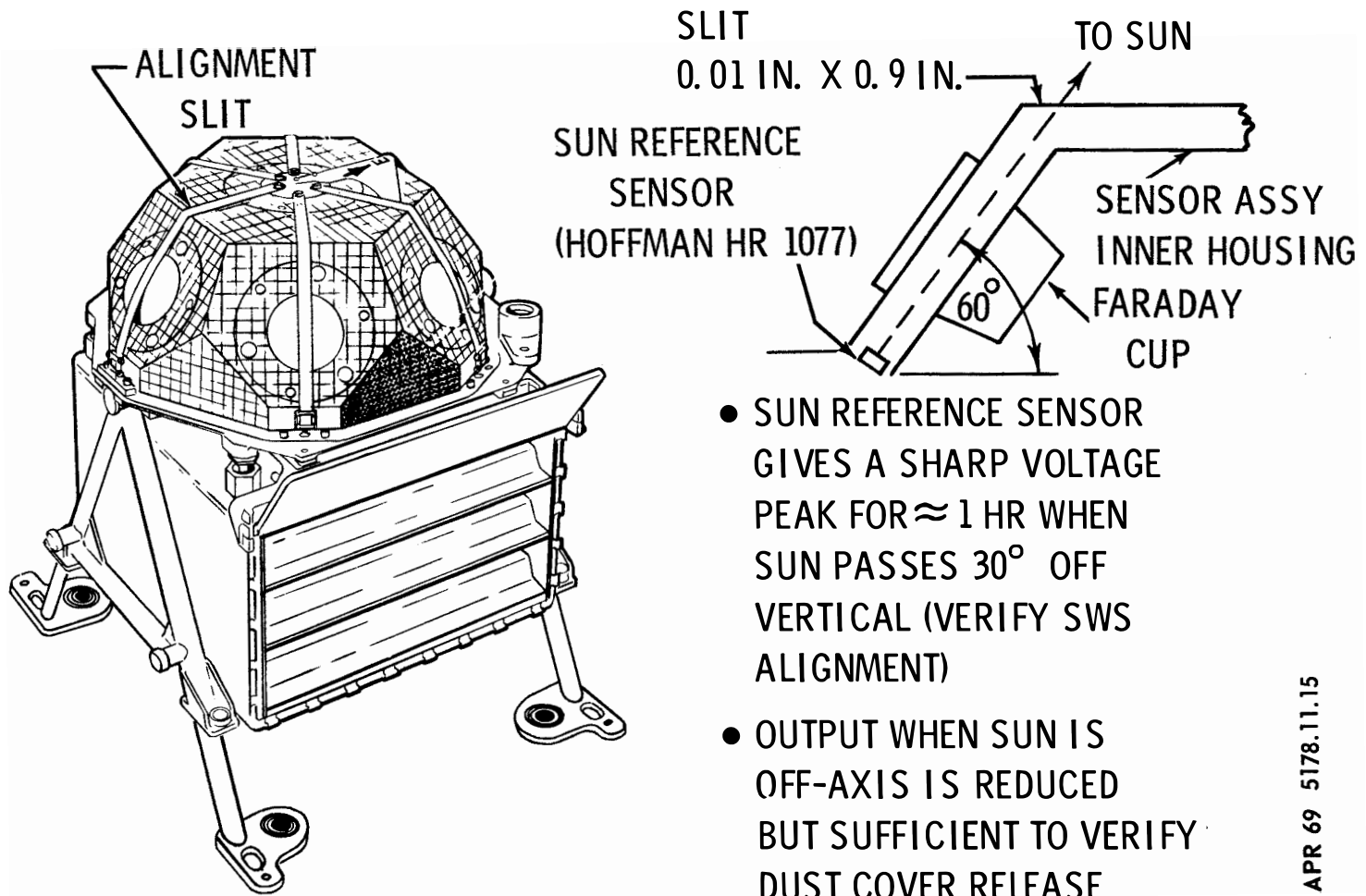

- SUN REFERENCE SENSOR GIVES A SHARP VOLTAGE PEAK FOR ≈ 1 HR WHEN SUN PASSES 30° OFF VERTICAL (VERIFY SWS ALIGNMENT)
- OUTPUT WHEN SUN IS OFF-AXIS IS REDUCED BUT SUFFICIENT TO VERIFY DUST COVER RELEASE

SWS COMMANDS

OCTAL CMD NUMBER

122 SWS CVR GO

CMD 122 CAUSES THE ONE TIME FUNCTION OF REMOVING THE SWS DUST COVERS. THIS CMD IS AN IRREVERSIBLE FUNCTION AND IS NECESSARY TO OBTAIN SWS SCIENTIFIC DATA.

122-122-122 HV GAIN CHANGE

TRANSMISSION OF CMD 122 THREE TIMES WITHIN 10 SEC SWITCHES THE VOLTAGE CONTROL AMPLIFIER FROM THE INITIAL (TURN-ON) LOW GAIN MODE TO THE HIGH GAIN MODE. BOTH GAIN SETTINGS WILL BE USED FOR SCIENTIFIC DATA COLLECTION. LOW GAIN MINIMIZES POSSIBILITY OF ARCING.

SWS DATA FORMAT

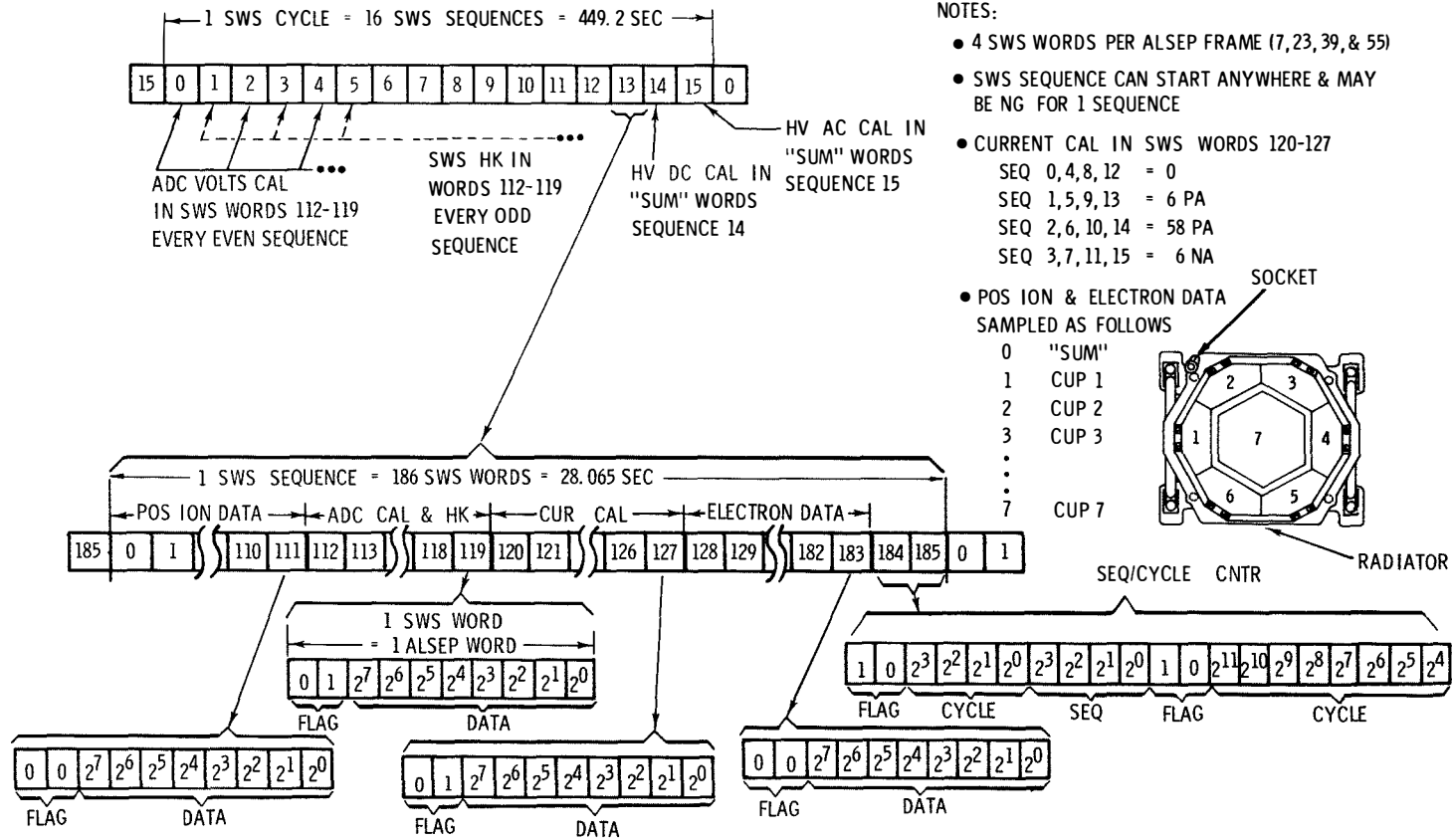

SUPRATHERMAL ION DETECTOR EXPERIMENT (SIDE)

- COMPONENTS & FUNCTIONS
- DEPLOYMENT
- COMMANDS & DATA

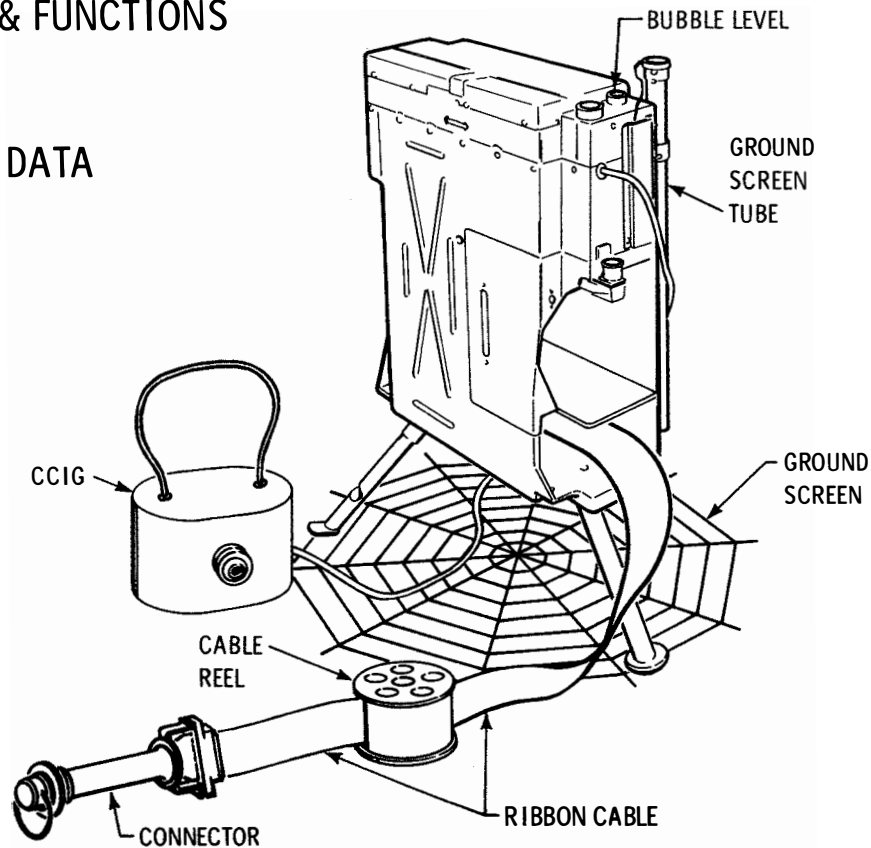

APR 69 5178.12.1

ION DETECTOR INSTRUMENT

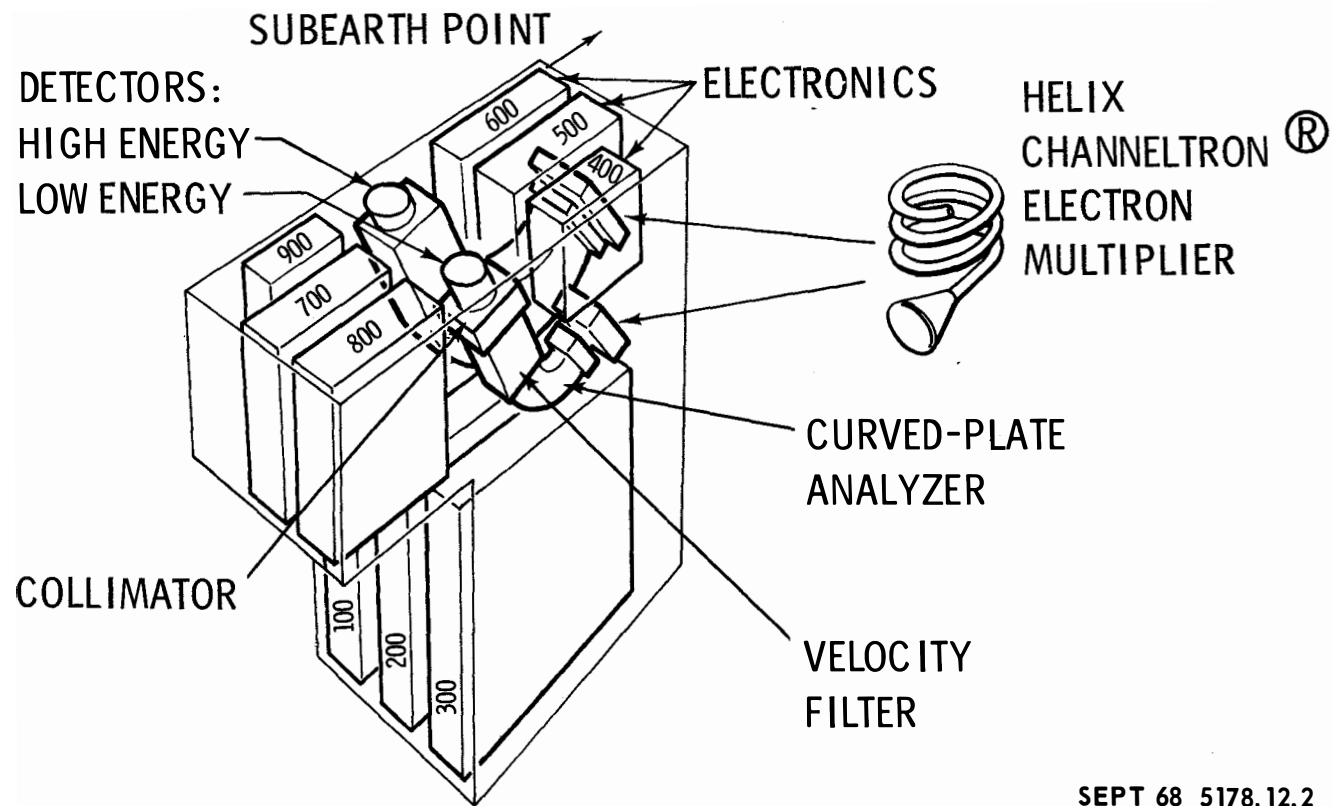

SEPT 68 5178.12.2

CCIG INSTRUMENT

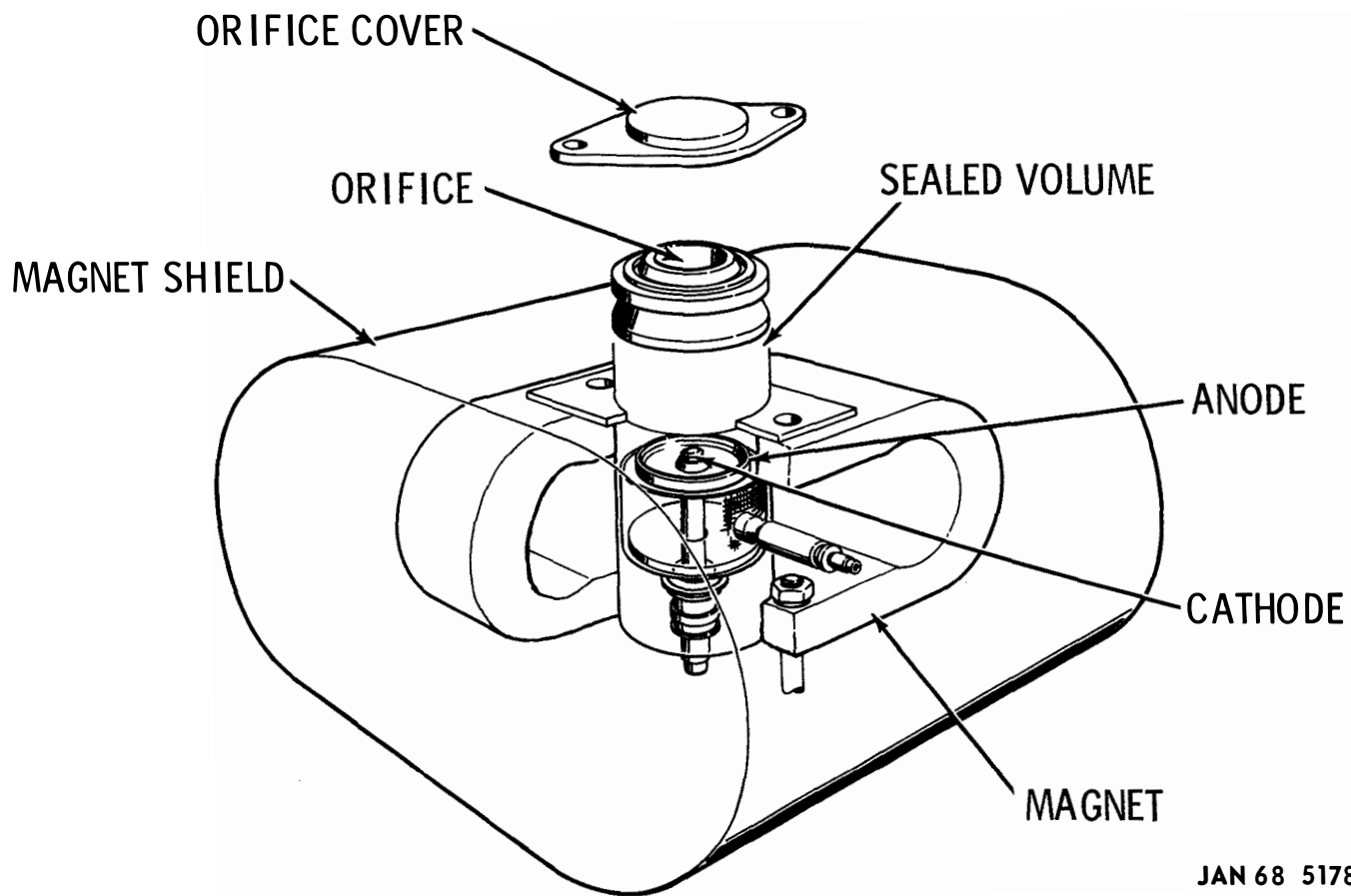

JAN 68 5178.12.3

SIDE GENERAL FEATURES

MEASURE IONIC ENVIRONMENT OF MOON		
<p>DETECT POSITIVE IONS</p> <ul style="list-style-type: none"> ● RESULTING FROM UV IONIZATION OF THE LUNAR ATMOSPHERE ● FREE STREAMING & THERMALIZED SOLAR WIND 		<p>DETERMINE</p> <ul style="list-style-type: none"> ● DENSITY OF LUNAR ATMOSPHERE (INC CHANGES WITH TIME) ● LOSS RATE OF CONTAMINANTS LEFT BY ASTRONAUT & LM
<p>HIGH ENERGY CURVED PLATE ANALYZER (HECPA)</p> <ul style="list-style-type: none"> ● NO VELOCITY FILTER ● DETERMINES FLUX (PARTICLES/SEC) WITHIN STEPPED RANGES OF ENERGY PER UNIT CHARGE 	<p>LOW ENERGY CURVED PLATE ANALYZER (LECPA)</p> <ul style="list-style-type: none"> ● PRECEDED BY VELOCITY FILTER (CROSSED ELECTRIC & MAGNETIC FIELDS) ● DETERMINES FLUX (PARTICLES/SEC) WITHIN STEPPED RANGES OF VELOCITY & ENERGY PER UNIT CHARGE 	<p>COLD CATHODE ION GAUGE (CCIG)</p> <ul style="list-style-type: none"> ● MEASURES DENSITY OF NEUTRAL ATOMS (THIS, WITH TEMP OF GAUGE, ALLOWS CALCULATION OF LUNAR ATMOSPHERE PRESSURE)
<ul style="list-style-type: none"> ● PLACED ON GROUND PLANE (WIRE MESH SCREEN) WITH VOLTAGE APPLIED BETWEEN INSTRUMENT & SCREEN TO ASSESS LUNAR SURFACE ELECTRICAL FIELD EFFECTS ● SIDE ELECTRONICS INPUT CIRCUITS PROVIDE ISOLATION FROM ALSEP (POWER & SIGNAL) 		

JAN 68 5178.12.4

SIDE PERFORMANCE

HECPA

- ENERGY RANGE: 10 ev TO 3500 ev PER UNIT CHARGE
- ANGLE OF COVERAGE: $30^{\circ} \times 6^{\circ}$
- ALIGNMENT:
 - + 5° TO LUNAR EQUATOR
 - 15° OFF VERTICAL & POINTED AWAY FROM SUB-EARTH POINT
- MEASUREMENT TECHNIQUE: CURVED PLATE ANALYZER FOLLOWED BY CHANNELTRON[®] ELECTRON MULTIPLIER
 - CURVED PLATE ANALYZER USES ELECTROSTATIC FIELD (BALANCED POTENTIAL ON PLATES) TO PERFORM ENERGY RESOLUTION
 - PLATE VOLTAGES: 20 STEPS BETWEEN 2.5 & 875 VOLTS
 - ELECTRON MULTIPLIER DETECTS IONS PASSED BY CURVED PLATE ANALYZER & SUPPLIES CURRENT PULSE ($>10^{-13}$ COULOMBS) TO PREAMP
 - ELECTRON MULTIPLIER OPERATES WITH -3500 VOLT EXCITATION

CCIG

- RANGE: 10^{-6} TO 10^{-12} TORR
- OPERATING VOLTAGE: +4500 V
- MAGNETIC FIELD: 1020 GAUSS
- POWER DISSIPATION: 5 MILLIWATTS
- GAGE BODY CONSTRUCTED OF 304 STAINLESS STEEL
- THREE OVERLAPPING MEASUREMENT RANGES (SWITCHED BY INTERNAL LOGIC) HANDLE CURRENT MEASUREMENTS BETWEEN 1×10^{-13} & 1×10^{-6} AMPS
- PLACED ON SURFACE OUTSIDE GROUND PLANE

LECPA

- RANGE:
 - MASSES UP TO 130 AMU
 - ENERGIES 0.2 EV TO 48.6 EV PER UNIT CHARGE
 - VELOCITIES 4×10^4 CM/SEC TO 9.35×10^6 CM/SEC
- ANGLE OF COVERAGE: $30^{\circ} \times 6^{\circ}$
- ALIGNMENT:
 - + 5° TO EQUATOR
 - 15° OFF VERTICAL & POINTED AWAY FROM SUB-EARTH POINT
- MEASUREMENT TECHNIQUE: VELOCITY FILTER, FOLLOWED BY CURVED PLATE ANALYZER, FOLLOWED BY CHANNELTRON[®] ELECTRON MULTIPLIER
 - VELOCITY FILTER: WEIN TYPE (CROSSED ELECTRIC & MAGNETIC FIELDS)
 - 500 GAUSS ALNICO, DOUBLE-C CONSTRUCTION MAGNET (62.5 GRAMS)
 - PARALLEL ELECTRICAL PLATES WITH BALANCED POTENTIAL HAVING 120 STEPS BETWEEN 0.12 & 28 VOLTS
 - CURVED PLATE ANALYZER HAS 6 STEPS BETWEEN 0.1 & 24.3 VOLTS
 - ELECTRON MULTIPLIER SAME AS HECPA

GROUND PLANE

- WIRE MESH SCREEN \approx 2 FT DIAM
- 24 VOLTAGE STEPS (11 POSITIVE, 11 NEGATIVE, & 2 ZEROS) BETWEEN -27.6 & +27.6 VOLTS

JAN 68 5178.12.5

SIDE BLOCK DIAGRAM

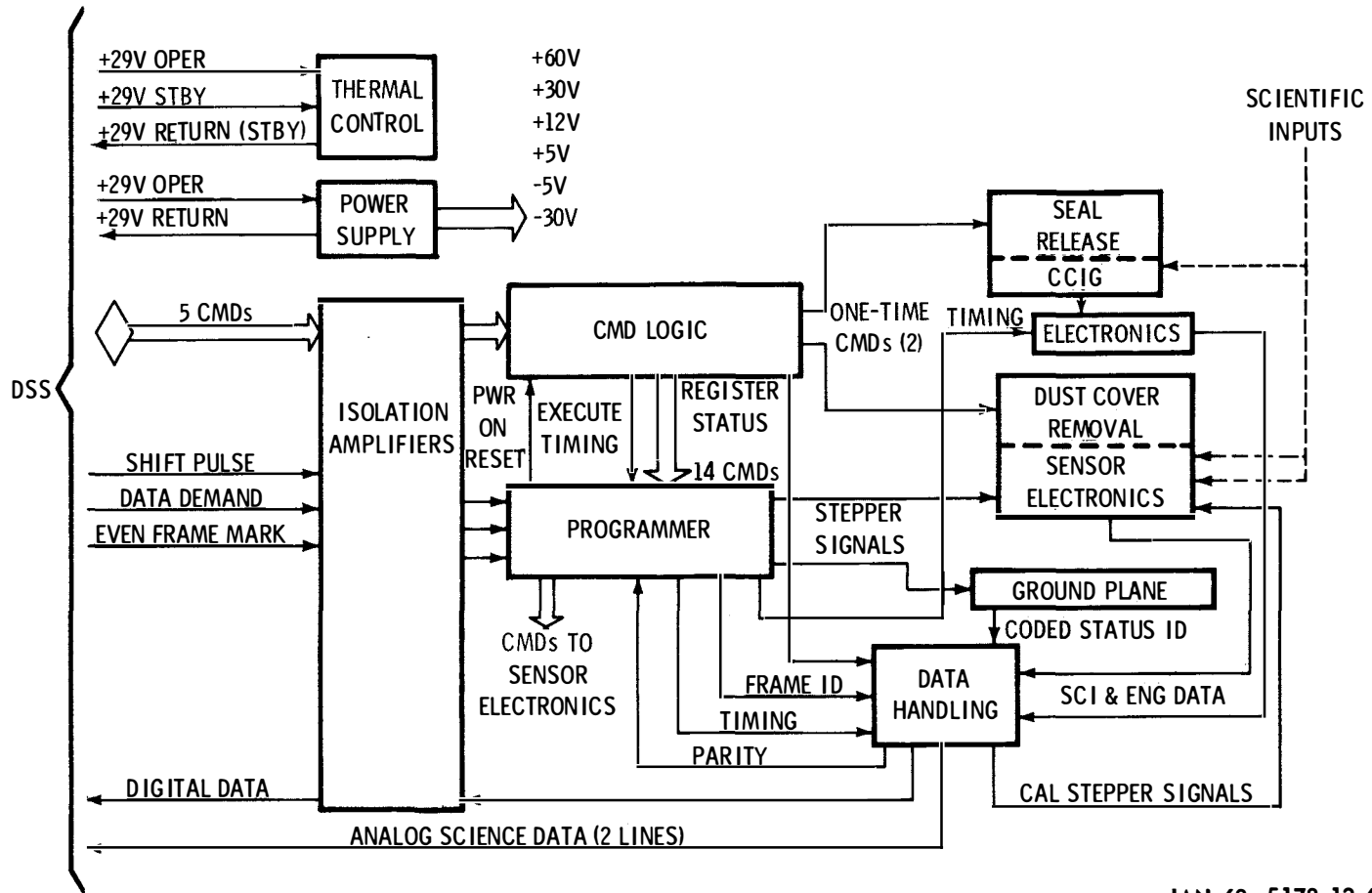

SIDE COMMAND FUNCTION

- ALSEP SUPPLIES 5 CMDs:

<u>OCTAL</u>	<u>NAME</u>	
104	SIDE LOAD 1	} TRANSMITTED FIRST. AFTER PROPER LOADING OF SIDE CMD INPUT REGISTER IS VERIFIED VIA TM, THEN EXECUTE IS TRANSMITTED.
105	SIDE LOAD 2	
106	SIDE LOAD 3	
107	SIDE LOAD 4	
110	SIDE EXECUTE	

- IF LOAD CMDs ARE NOT PROPERLY RECEIVED, INPUT REGISTER CAN BE CLEARED BY TRANSMITTING ALL LOADS (1, 2, 3 & 4) & THEN EXECUTE
- SIDE ENCODES 15 DIFFERENT CMD COMBINATIONS (INC REGISTER RESET)
- TWO OF THE 15 ARE ALSO USED (VIA ONE-TIME REGISTER) TO PERFORM THE ONE-TIME FUNCTIONS OF CCIG SEAL BREAK & SIDE DUST COVER REMOVAL (THE FIRST TIME THEY ARE TRANSMITTED)
- CMDs ARE STROBED FROM INPUT REGISTER (BUFFER) TO MODE REGISTER WHEN EXECUTED (SIMULTANEOUSLY DECODED & APPLIED)
- TM OF MODE REGISTER INDICATES WHAT THE LAST CMD WAS; THEREFORE, HELPS VERIFY WHAT MODE THE SIDE IS IN

SIDE COMMAND ENCODING

ALSEP OCTAL CMD SEQUENCE					SYMBOL	FUNCTION	COMMENTS
104	105	106	107	110			
	X		X	X	CI-01	CCIG SEAL BREAK	} ONE-TIME CMDs
			X	X	CI-02	SIDE DUST COVER GO	
X				X	CI-06	GROUND PL STEP PROG ON/OFF	} THESE CMDs REPETITIVE MODIFY DATA CMDs OUTPUT MODE BY CHANGING LENGTH OF SIDE SEQUENCE OR CYCLE
	X			X	CI-07	RST SIDE FRAME CNTR AT 10	
X	X			X	CI-08	RST SIDE FRAME CNTR AT 39	
		X		X	CI-09	RST V/FILT CNTR AT 9	
X		X		X	CI-10	RST SIDE FRAME CNTR AT 79	
	X	X		X	CI-11	RST CNTRs AT 79 & 9	
X	X	X		X	CI-12	X10 ACCUM INTERVAL ON/OFF	
			X	X	CI-13	MASTER RST (NORMAL MODE SEL)	
X			X	X	CI-14	V/FILT VOLTAGE ON/OFF	} CMDs AFFECTING STEPPER VOLTAGES DATA CHANGE (SHORT SEQUENCE) POWER SWITCHING
	X		X	X	CI-15	LECPA HIGH VOLTAGE ON/OFF	
X	X		X	X	CI-16	HECPA HIGH VOLTAGE ON/OFF	
		X	X	X	CI-17	FORCE CONTINUOUS CAL	
X		X	X	X	CI-18	CCIG HIGH VOLTAGE ON/OFF	
	X	X	X	X	CI-19	CHANNELTRON HV ON/OFF	
X	X	X	X	X	CI-20	RST CMD INPUT REGISTER	} INTERNAL TO CMD LOGIC
				X	NA	NOT USED	

SIDE COMMAND LOGIC DIAGRAM

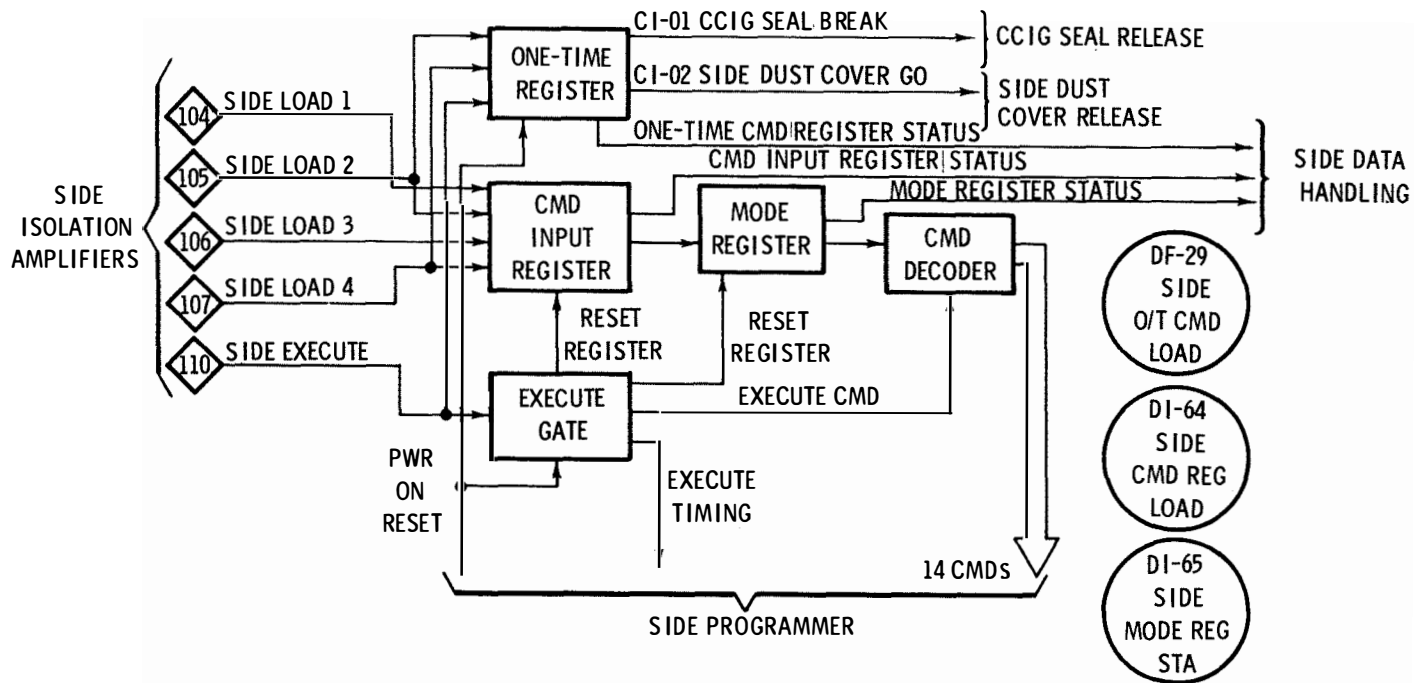

SIDE PROGRAMMER FUNCTION

- PROVIDES TIMING & CONTROL SIGNALS TO
 - HECPA
 - VELOCITY FILTER
 - LECPA
 - CALIBRATION PULSER
 - GROUND PLANE
 - CCIG
- BASIC TIME REFERENCE IS GENERATED IN SIDE FRAME COUNTER
 - NORMALLY COUNTS 128 ALSEP EVEN FRAME MARKS (256 ALSEP FRAMES)
 - INITIATES HECPA, VELOCITY FILTER, & LECPA STEPS (ETC.) AT PROPER TIME IN SIDE FRAME, DEPENDING ON SIDE FRAME COUNT
 - COUNTER OPERATION MAY BE MODIFIED VIA GROUND CMD TO COUNT LESS THAN 128 (0-79, 0-39, 0-10, 120-127)
 - GROUND PLANE STEPS ONCE AT EACH SIDE FRAME COUNTER RESET UNLESS INHIBITED VIA GROUND CMD (24 GROUND PLANE STEPS)

APR 69 5178.12.10

SIDE PROGRAMMER DIAGRAM

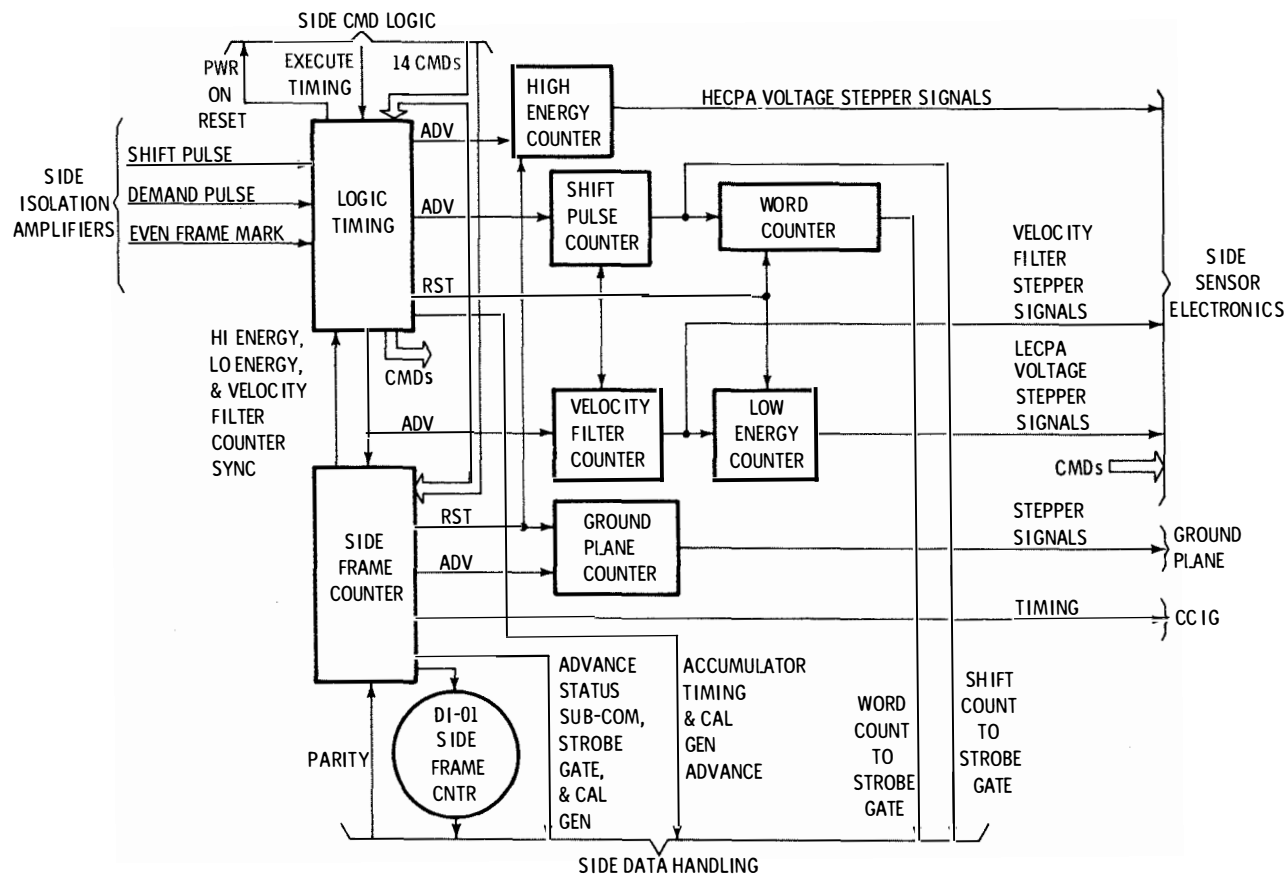

JAN 68 5178.12.11

SIDE ION DETECTION

- POSITIVE IONS PASSING THROUGH VELOCITY FILTER & LECPA (OR THROUGH HECPA) ARE DETECTED BY ELECTRON MULTIPLIERS WHICH SUPPLY A CURRENT PULSE, FOR EACH ION THAT ENTERED, TO DETECTOR AMPLIFIERS (DISCRIMINATORS)
- DISCRIMINATORS SEPARATE PULSES FROM BACKGROUND NOISE & AMPLIFY PULSE SIGNALS (ALSO LIMIT OUTPUT TO \approx ONE PULSE PER MICROSECOND)
- PULSES ARE APPLIED TO COUNT ACCUMULATORS (IN DATA HANDLING) & TO LOGARITHMIC COUNT RATE METERS (4V = 40,000 CNTS/SEC; 1V = 50 CNTS/SEC)
- WHEN SIDE FRAME COUNTER READS 120 TO 127 (EVERY 2.5 MIN, APPROX, AT NORMAL RATE) CAL SIGNAL PULSES ARE GATED THROUGH THE DETECTOR AMPLIFIERS AT THE FOLLOWING FREQUENCIES:

0	Hz (BACKGROUND)	} IN SEQUENCE
136.72	Hz	
17,500	Hz	
560,000	Hz	

- DURING CALIBRATION, THE STEPPING VOLTAGES OF HECPA & LECPA ARE PROGRAMMED TO ZERO & THE VELOCITY FILTER TO THE MAXIMUM POSITIVE. THIS PREVENTS ION COUNTS DURING CALIBRATION
- SIDE DUST COVER RELEASED BY SOLENOID-OPERATED CATCH VIA GROUND CMD

JAN 68 5178.12.12

SIDE SENSOR ELECTRONICS

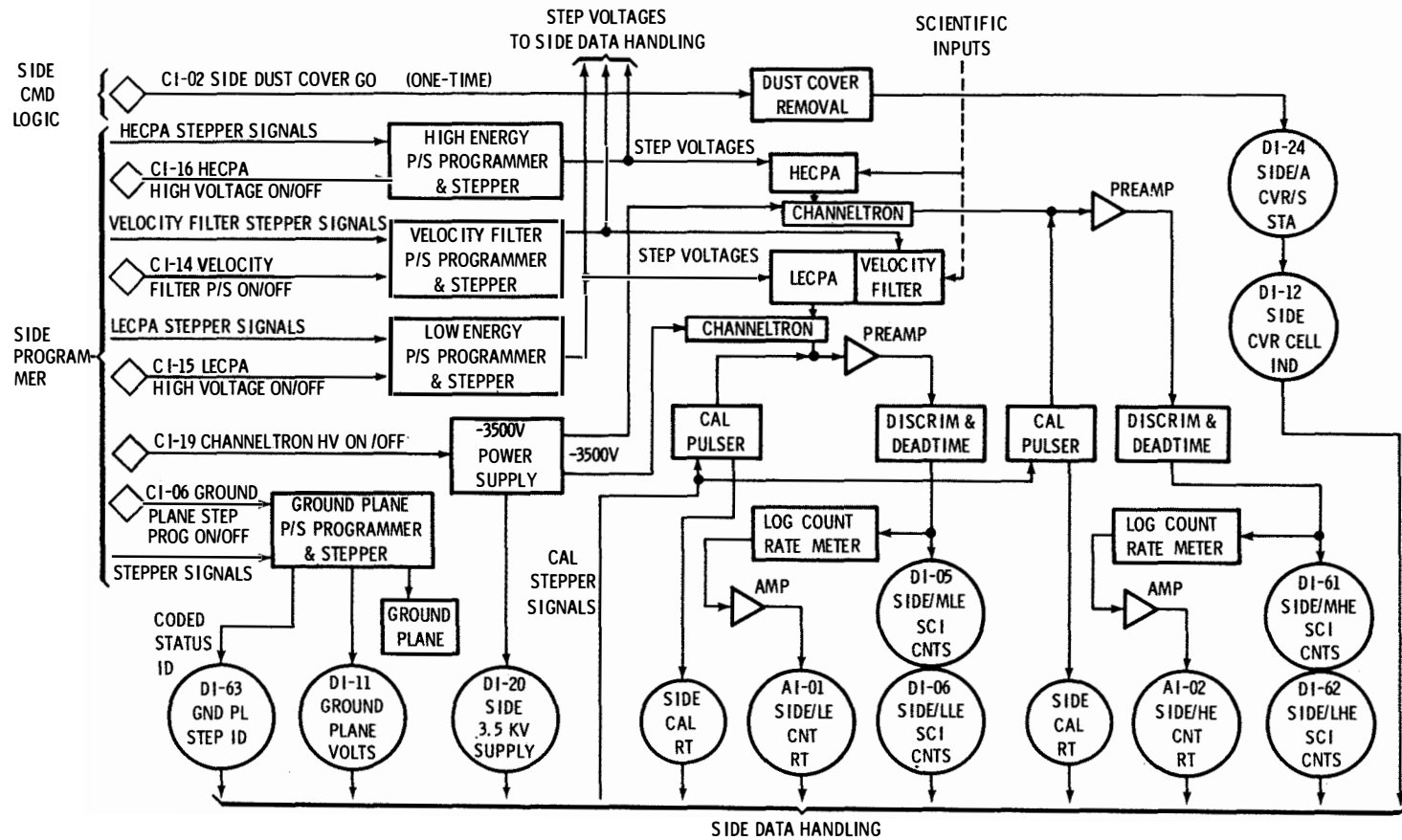

JAN 68 5178.12.13

CCIG FUNCTION

- CHARGED PARTICLES ENTERING THE SENSOR ARE DEFLECTED INTO ELONGATED SPIRAL PATHS BY THE COMBINATION OF MAGNETIC & ELECTROSTATIC FIELDS
- THESE PARTICLES COLLIDE WITH NEUTRAL ATOMS PRODUCING A LARGE NUMBER OF IONS & A CURRENT FLOW (DEPENDING ON THE NUMBER OF ATOMS) BETWEEN CATHODE & ANODE
- ELECTROMETER AMPLIFIER AMPLIFIES THE CURRENT FOR INPUT TO DATA HANDLING
- AUTOMATIC RANGE SELECTION (ALSO READ OUT VIA TM)
- THE NO-ION COUNT OUTPUT OF THE ELECTROMETER PROVIDES AUTOMATIC ZERO CORRECTION
- UPON DEMAND FROM SIDE FRAME COUNTER, A SEQUENCE OF PRECISELY CONTROLLED CURRENTS ARE GATED THROUGH THE ELECTROMETER INPUT CIRCUITS FOR CALIBRATION
- CCIG SEAL IS REMOVED BY AN EXPLOSIVE PISTON ACTUATOR (PIN-PULLER) WHICH RELEASES SPRING-LOADED COVER

JAN 68 5178.12.14

CCIG DIAGRAM

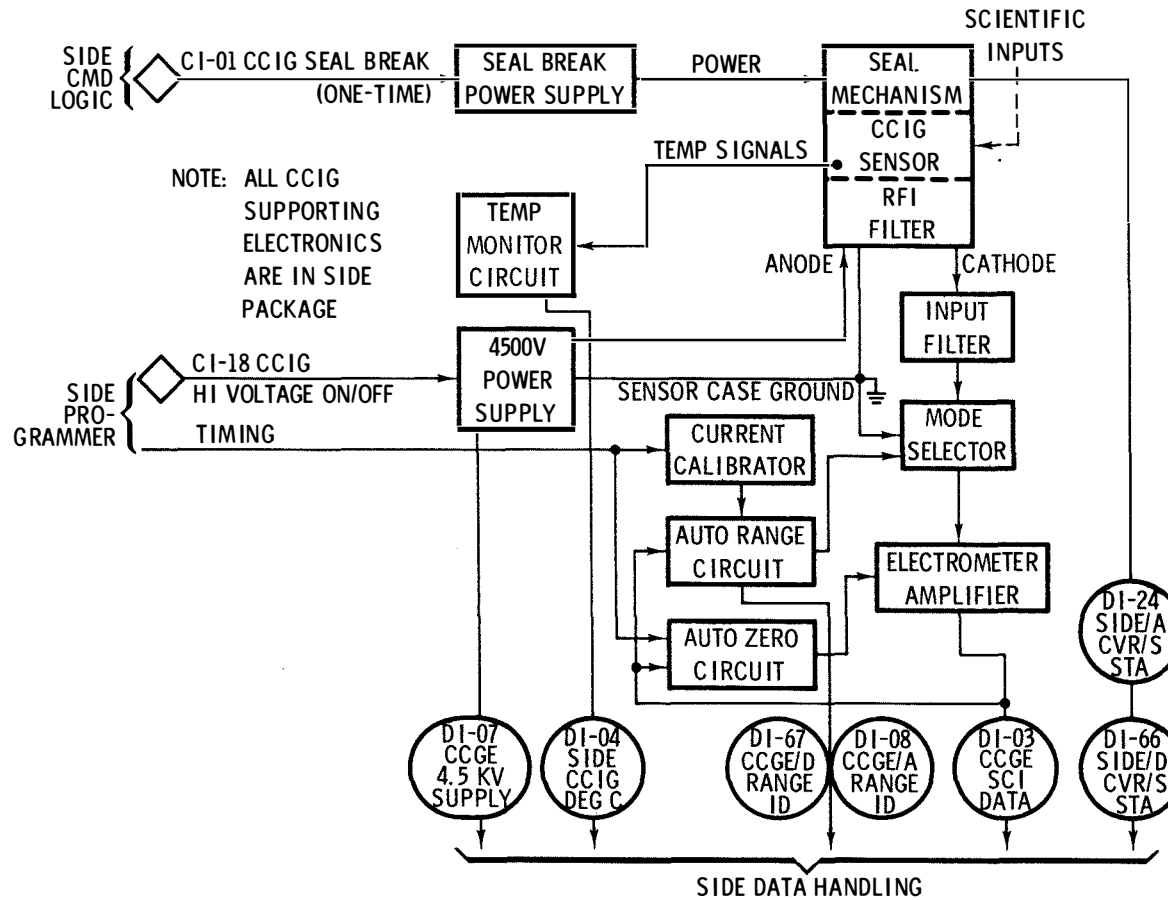

SIDE DATA HANDLING

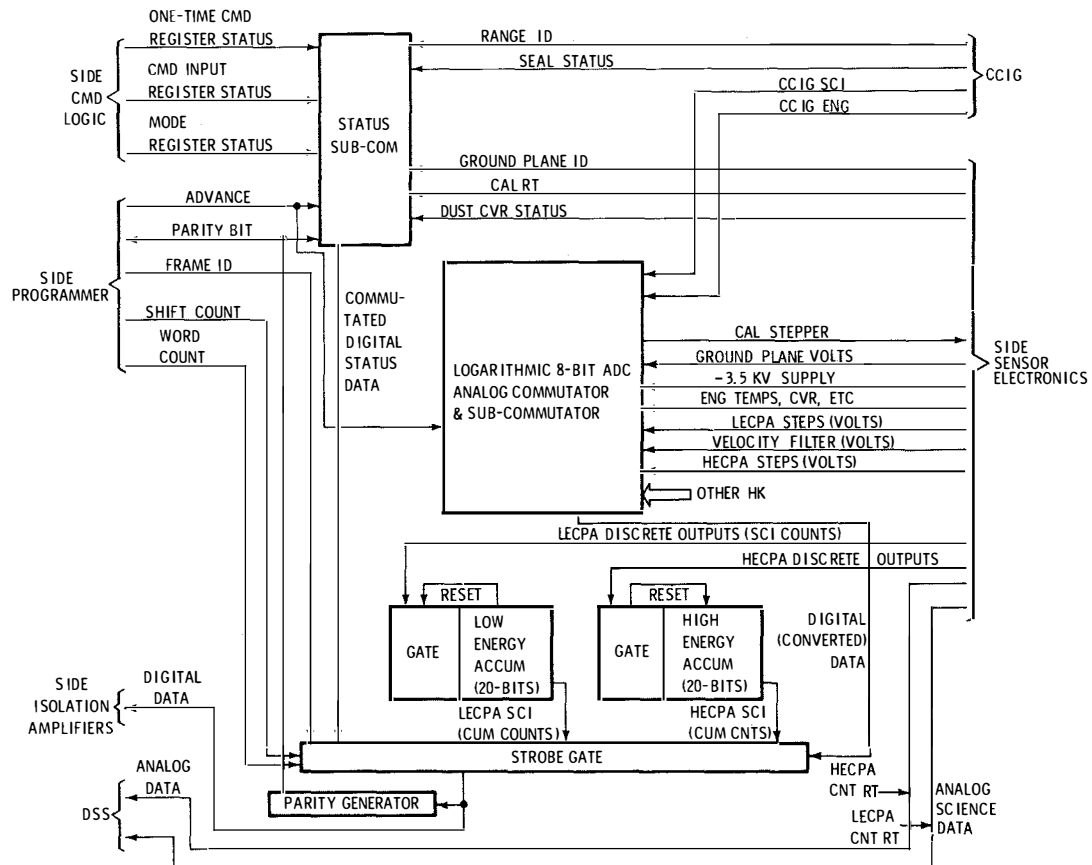

JAN 68 5178.12.16

SIDE THERMAL CONTROL

MECHANICAL

- OPERATING RANGE FOR ELECTRONICS:
-20° C TO +80° C
- ELECTRONICS PACKAGE HAS OUTER GOLD COVER, OUTER CASE HAS INNER GOLD SURFACE (TWO GOLD SURFACES FACING EACH OTHER)
- OUTSIDE SURFACE OF OUTER CASE PAINTED WHITE
- BOTTOM OF CASE HAS THIN INSULATION BLANKET BETWEEN LEGS
- TOP OF PACKAGE HAS SECOND SURFACE MIRROR RADIATOR
 - DUST COVER PROTECTS MIRROR & APERTURES FROM DUST UNTIL AFTER LM ASCENT (ALSO PROTECTS ASTRONAUT FROM MIRROR REFLECTIONS)
 - CONDUCTIVE GRID OVER MIRROR PROVIDES EQUIPOTENTIAL SURFACE AROUND APERTURES

ELECTRICAL

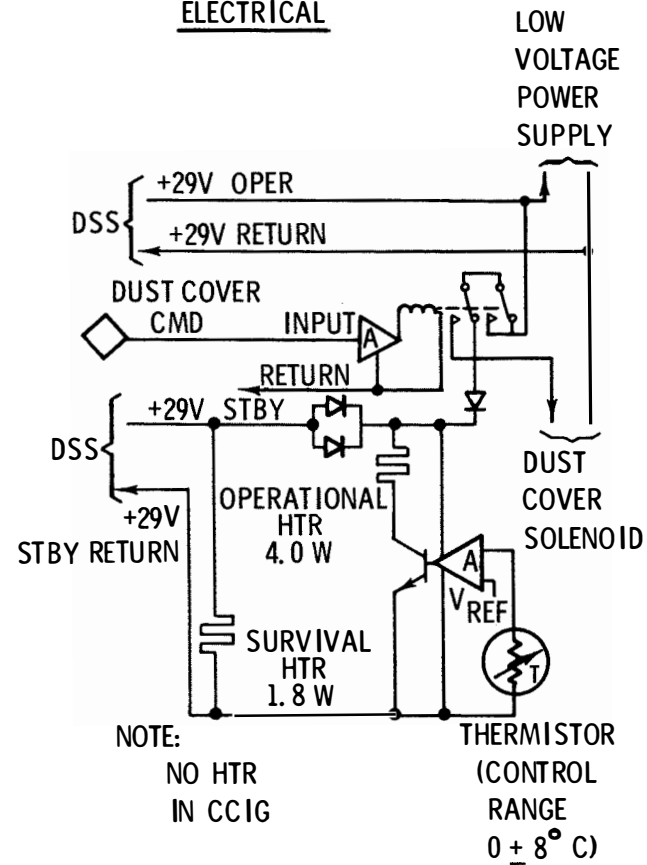

APR 69 5178.12.17

SIDE POWER SUPPLY

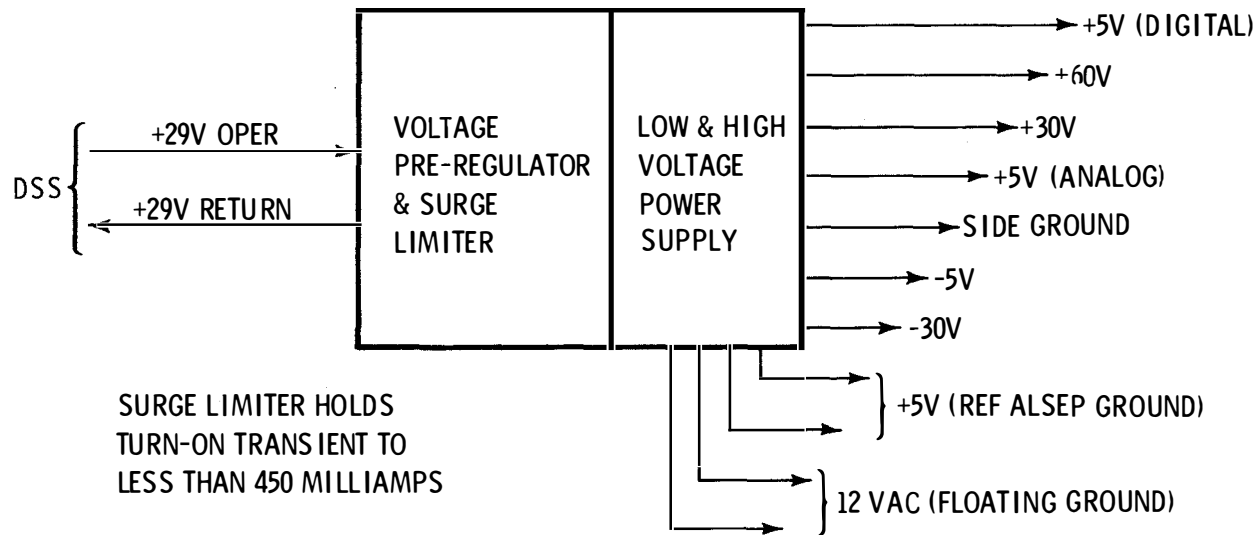

SPECIAL PURPOSE POWER SUPPLIES:

- STEPPERS

HECPA 1. 25V TO 438V

LECPA 0. 05V TO 12. 15V

VELOCITY FILTER 0. 06V TO 14V

} BALANCED VOLTAGES,

+ ON ONE TERMINAL

- ON OTHER TERMINAL

- CHANNELTRON[®] ELECTRON MULTIPLIER -3500V

- COLD CATHODE ION GAUGE +4500V

JAN 68 5178.12.18

SIDE POWER PROFILE

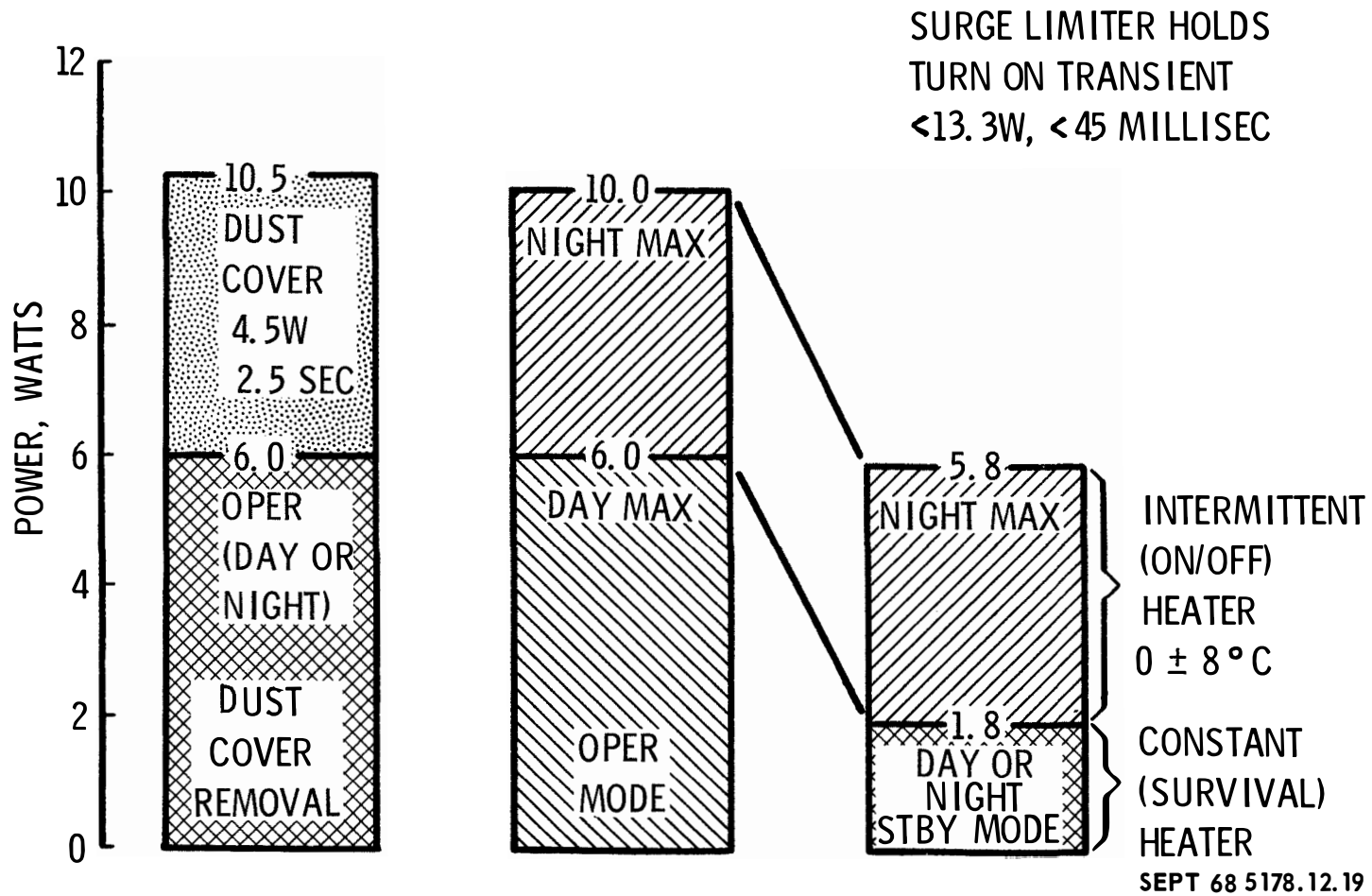

SIDE TIE-DOWN AND RELEASE

- SIDE ON SUBPALLET OF SUBPACK 2
- ASTRONAUT RELEASES 5 FASTENERS
 - 1 EXPER TIE-DOWN RELEASED BY ROTATING GROUND SCREEN TUBE
 - 4 EXPER TIE-DOWNS RELEASED BY USING UHT
 - CONNECTOR RELEASED BY USING UHT
- EXPERIMENT LIFTED USING UHT IN HANDLING SOCKET
- CONNECTOR LIFTED BY LANYARD
- ASTRONAUT DEPLOYS LEGS BY PULLING LANYARD
- PLACES EXPER ON LUNAR SURFACE
- PLUGS CONNECTOR INTO CENTRAL STATION
- REMOVES SCREEN FROM TUBE & DEPLOYS SCREEN
- LIFTS EXPER
- REMOVES CC IG
- STANDS EXPER ON SCREEN
- DEPLOYS CC IG (OFF SCREEN)

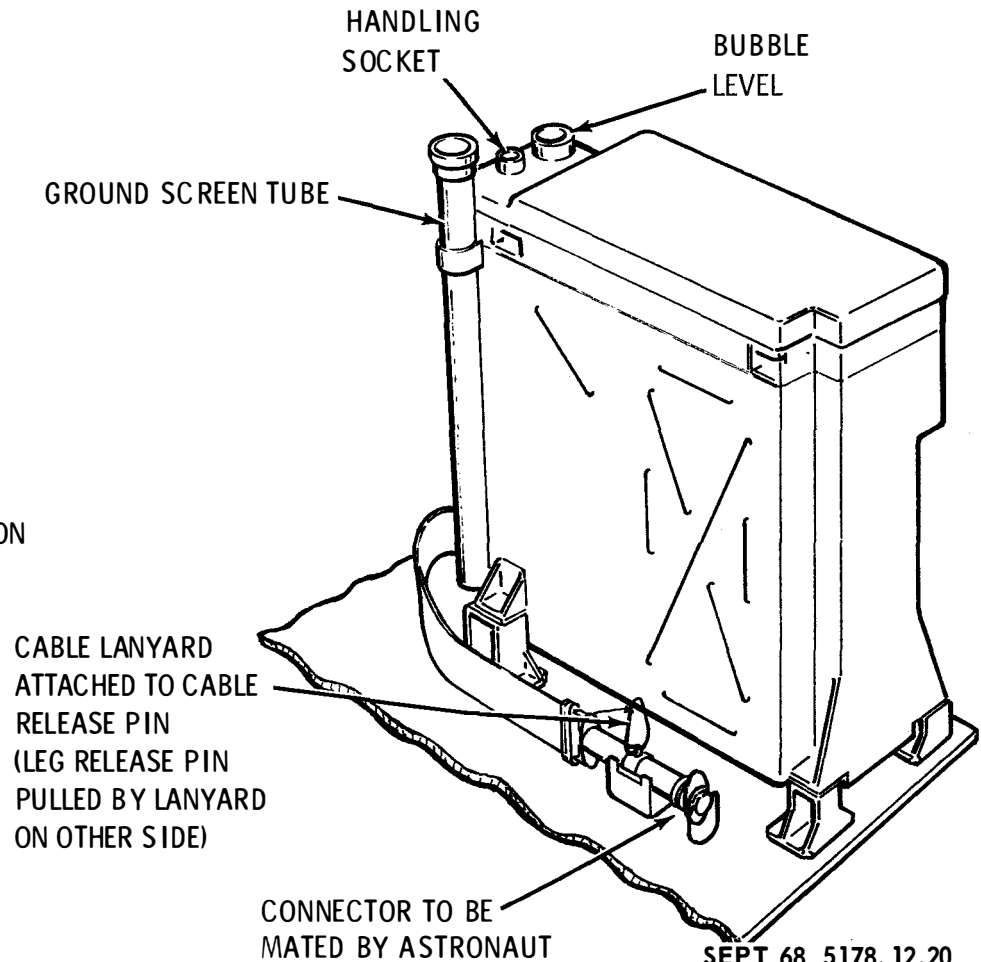

SIDE EMPLACEMENT CRITERIA

	PARAMETER	REQUIREMENT	PRIORITY	INDICATOR	COMMENTS
DETECTOR	DISTANCE FROM SUBPACKAGE 1	55 ±5 FT	2	60 FT CABLE	TO MINIMIZE INTERFERENCE AT LSM LOCATION
	DIRECTION FROM SUBPACKAGE 1	110° ±10° FROM LSM (I. E., ≈70° FROM LM)	2	EYEBALL	TO OBTAIN 80 FT SEPARATION FROM LSM & PREFERABLY 100 FT
	SITE SELECTION	SMOOTH	1	EYEBALL	SUITABLE FOR SCREEN
	LEVEL, WRT INDICATOR	5° OF HORIZ	1	BUBBLE	INTERACTS WITH ALIGNMENT
	ALIGN, WRT SHADOW	10° OF E-W	2	ARROW*	THERMAL & SCIENTIFIC REQUIREMENT
ION GAUGE	POSITION	OFF SCREEN, OPPOSITE LM, 5 FT FROM DETECTOR	1	5 FT CABLE	TO SATISFY ALIGNMENT REQUIREMENTS
	ALIGN ORIFICE	20° OF N OR S	2	PAINT	AWAY FROM (±90°) ALL SUBSYSTEMS, LM, SUN & EARTH
	EXPERIMENT INTERRELATION	HEAVY MAGNET IN ION GAGE IS SHIELDED. IT AND MAGNETIC FIELD OF DETECTOR MUST BE SEPARATED FROM LSM (DIRECTION CRITERIA NOT PERTINENT ON OTHER EXPERIMENT COMBINATIONS)			
	SPECIAL REQUIREMENTS	*ARROW MUST POINT TOWARD SUBEARTH POINT (E OR W); HENCE, EXPERIMENT IS NOT BIDIRECTIONAL. FINAL ALIGNMENT IS BY SHADOWS ON LONG SIDES OF DETECTOR.			

SEPT 68 5178.12.21

SIDE ALIGNMENT MARKINGS

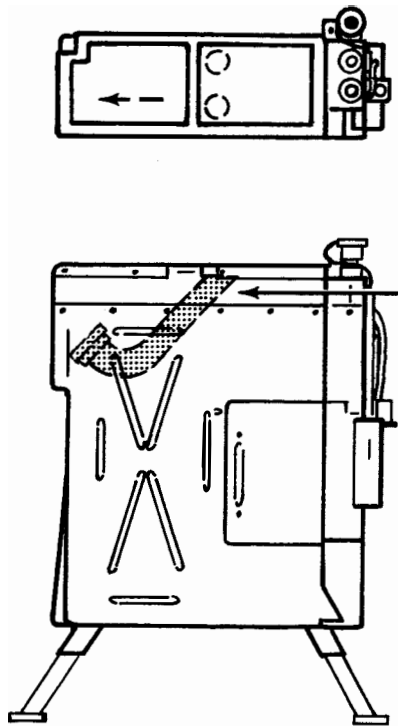

DETECTORS

- ARROW POINTS EAST OR WEST: ($\pm 5^\circ$)
BUT TOWARD THE SUBEARTH POINT
- DETECTORS POINT AWAY FROM SUBEARTH POINT

APR 69 5178.12.22

SIDE COMMANDS

OCTAL CMD NUMBERS

(105 & 110) CCIG SEAL BREAK

THIS CMD (C1-01) CAUSES THE ONE TIME FUNCTION OF CCIG SEAL BREAK. IT SIMULTANEOUSLY RESETS THE SIDE FRAME COUNTER AT 10 (DESCRIBED LATER). THIS CMD IS AN IRREVERSIBLE FUNCTION AND IS NECESSARY TO OBTAIN CCIG SCIENTIFIC DATA. THIS CMD IS ALSO GENERATED BY THE DELAYED CMD SEQUENCER (ALSEP TIMER).

(107 & 110) SIDE DUST COVER GO

THIS CMD (C1-02) CAUSES THE ONE TIME FUNCTION OF REMOVING THE SIDE DUST COVER. IT SIMULTANEOUSLY RESETS THE SIDE MASTER RESET (DESCRIBED LATER). THIS CMD IS AN IRREVERSIBLE FUNCTION AND IS NECESSARY TO OBTAIN SIDE SCIENTIFIC DATA. THIS CMD IS ALSO GENERATED BY THE DELAYED CMD SEQUENCER (ALSEP TIMER).

NOTE THE SIDE DUST COVER CAN BE REMOVED BY SENDING ANY CMD CONTAINING A 107 FOLLOWED BY 110 (SIMILARLY, SEAL BREAK 105 & 110).

HEATER CIRCUIT AUTOMATICALLY INTERRUPTED TO AVOID EXCESSIVE CURRENT DEMAND.

(104 & 110) GROUND PLANE STEP PROGRAM ON/OFF

THIS CMD (C1-06) IS A 2-STATE CMD (ON/OFF) THAT CONTROLS THE OPERATION OF THE GROUND PLANE STEP PROGRAMMER. SIDE ACTIVATION PRESETS THE PROGRAMMER TO ON. THE GROUND PLANE VOLTAGE IS THEN STEPPED THROUGH TWENTY-FOUR LEVELS (ONE LEVEL/SIDE SEQUENCE). TRANSMISSION OF THIS CMD WILL CAUSE THE STEP PROGRAMMER TO STOP AND HOLD A FIXED VOLTAGE. RE-TRANSMISSION WILL START THE STEP PROGRAMMER AND DOES NOT RESET VOLTAGE LEVEL TO ZERO BUT CONTINUES TO STEP FROM THE PREVIOUS LEVEL.

(105 & 110) RESET SIDE FRAME COUNTER AT 10

THIS CMD (C1-07) IS A MODE CMD. (INITIATION OF A MODE CMD CHANGES THE OPERATIONAL DATA FORMAT CHARACTERISTICS). UPON RECEIPT OF THE CMD, THE EXPERIMENT RESETS TO SIDE FRAME ZERO, THEN STEPS NORMALLY TO SIDE FRAME 10 BEFORE RESETTING AGAIN TO ZERO. THE VELOCITY FILTER, HIGH AND LOW ENERGY CURVED PLATE ANALYZERS STEP THROUGH THE VALUES OBTAINED FOR THESE SIDE FRAMES IN THE NORMAL MODE OF OPERATION. THE GROUND PLANE VOLTAGE STEPS THROUGH THE NORMAL 24 STEPS, ONE STEP PER 11-FRAME SEQUENCE.

(104, 105 & 110) RESET SIDE FRAME COUNTER AT 39

THIS CMD (C1-08) IS A MODE CMD. UPON RECEIPT OF THE CMD, THE EXPERIMENT OPERATES IN A SIMILAR FASHION TO THE RESET AT 10 MODE EXCEPT THAT IT RESETS AT SIDE FRAME 39.

(106 & 110) RESET VELOCITY FILTER COUNTER AT 9

THIS CMD (C1-09) IS A MODE CMD. THE EXPERIMENT, IN THIS MODE, EXECUTES THE NORMAL 128 SIDE FRAME SEQUENCE. HOWEVER, THE VELOCITY FILTER VOLTAGE ONLY EXECUTES THE FIRST 10 OF ITS NORMAL 20-STEP PROGRAM. THAT IS, AT SIDE FRAME 10, INSTEAD OF COMPLETING THE 20 STEPS, THE VELOCITY FILTER ASSUMES THE VALUE OF SIDE FRAME 20 IN THE NORMAL MODE. SIMILARLY AT SIDE FRAME 20, THE FILTER ADOPTS THE NORMAL MODE VALUE OF SIDE FRAME 40. THIS OPERATION CONTINUES FOR THE COMPLETE 128 SIDE FRAMES. THE LOW ENERGY CURVED PLATE ANALYZER, INSTEAD OF MAINTAINING ITS VALUE FOR 20 SIDE FRAMES, STEPS TO THE NEXT VALUE EVERY 10 SIDE FRAMES. THIS MEANS THAT THE PROGRAM FROM SIDE FRAME 60 TO 119 IS A REPETITION OF 0 TO 59.

(104, 106 & 110) RESET SIDE FRAME COUNTER AT 79

THIS CMD (C1-10) IS A MODE CMD. UPON RECEIPT OF THE CMD, THE EXPERIMENT OPERATES IN A SIMILAR FASHION TO THE RESET AT 10 MODE EXCEPT THAT IT RESETS AT SIDE FRAME 79.

(105, 106 & 110) RESET FRAME CNTR AT 79 & FILTER CNTR AT 9

THIS CMD (C1-11) IS A MODE CMD. UPON RECEIPT OF THE CMD, THE EXPERIMENT PERFORMS PROGRAM OF RESET VELOCITY FILTER COUNTER AT 9, BUT THE PROGRAM STOPS AT SIDE FRAME 79 AND REPEATS.

THE PROGRAM STEPS FOR OTHER VOLTAGES AND DATA COMMUTATION ARE NORMAL UP TO SIDE FRAME 79.

(104, 105, 106 & 110) X10 ACCUMULATION INTERVAL ON/OFF

THIS CMD (C1-12) IS A 2-STATE CMD. REPEATED TRANSMISSION CHANGES THE ACCUMULATION PERIOD OF THE HECPA & LECPA SCIENCE DATA BACK & FORTH BETWEEN ≈ 1.2 SEC & ≈ 12 SEC. IN THE X10 SETTING, THE SIDE FRAME COUNTER & ASSOCIATED COMMUTATED ENGINEERING DATA ARE REPEATED 10 TIMES WHILE THE SCIENCE DATA READS PROGRESSIVE ACCUMULATIONS OF PULSES. AFTER 10 REPETITIONS AT A PARTICULAR SETTING, THE PROGRAM ADVANCES TO THE SETTINGS OF THE NEXT SIDE FRAME NUMBER.

THE X10 ACCUMULATION MODE CAN BE USED WITH ANY OF THE COUNTER RESET DATA MODES.

(107 & 110) MASTER RESET

THIS CMD (C1-13) IS A MODE CMD. UPON RECEIPT OF THE CMD, THE EXPERIMENT WILL RETURN TO THE NORMAL OPERATIONAL MODE AS FOLLOWS:

- REMOVE ALL SHORT SEQUENCES
- RESET SIDE FRAME COUNTER (INC HECPA, LECPA & VELOCITY FILTER COUNTERS)

NOTE: THIS DOES NOT DISTURB ANY ON/OFF CMDs (HV OR STEPPERS INC GROUND PLANE) OR X10 ACCUMULATION INTERVAL

(104, 107 & 110) VELOCITY FILTER VOLTAGE ON/OFF

THIS CMD (C1-14) IS A 2-STATE CMD. REPEATED TRANSMISSION TURNS ON & OFF THE POWER SUPPLY FOR VELOCITY FILTER STEPS.

(105, 107 & 110) LECPA HIGH VOLTAGE ON/OFF

THIS CMD (C1-15) IS A 2-STATE CMD. REPEATED TRANSMISSION TURNS ON & OFF THE POWER SUPPLY FOR LECPA STEPS.

(104, 105, 107 & 110) HECPA HIGH VOLTAGE ON/OFF

THIS CMD (C1-16) IS A 2-STATE CMD. REPEATED TRANSMISSION TURNS ON & OFF THE POWER SUPPLY FOR HECPA STEPS.

(106, 107, & 110) FORCE CONTINUOUS CALIBRATION

THIS CMD (C1-17) IS A MODE CMD. UPON RECEIPT OF THIS CMD, THE SIDE FRAME COUNTER IS RESET TO 120 AFTER WHICH IT STEPS FROM 120 THROUGH 127 (IN THE NORMAL SEQUENCE) AND REPEATS 120-127 UNTIL TRANSMISSION OF SOME OTHER CMD. THESE STEPS CONTAIN ALL OF THE CALIBRATION PROGRAMS: HENCE, THERE IS NO ENG OR SCI DATA (EXCEPT CCIG SCII).

(104, 106, 107 & 110) CCIG HIGH VOLTAGE ON/OFF

THIS CMD (C1-18) IS A 2-STATE CMD. REPEATED TRANSMISSION TURNS ON & OFF THE POWER SUPPLY FOR THE CCIG SENSOR. IN THE OFF CONDITION, THERE IS NO CCIG SCIENTIFIC DATA OUTPUT.

(105, 106, 107 & 110) CHANNELTRON HIGH VOLTAGE ON/OFF

THIS CMD (C1-19) IS A 2-STATE CMD. REPEATED TRANSMISSION TURNS ON & OFF THE EXCITATION POWER SUPPLY FOR THE CHANNELTRON[®] ELECTRON MULTIPLIERS OF HECPA & LECPA. THUS, IN THE OFF CONDITION THERE IS NO ION DETECTOR SCIENTIFIC DATA.

(104, 105, 106, 107 & 110) RESET COMMAND INPUT REGISTER

THIS CMD (C1-20) IS USED TO CLEAR THE CMD REGISTER OF ANY CMD AWAITING EXECUTION. IF A FAULTY CMD IS ENTERED IN THE REGISTER, THE MISSING SIDE LOAD CMDs ARE TRANSMITTED FOLLOWED BY SIDE EXECUTE (OCTAL 110). ACTUATES ONE-TIME CMDs IF THEY HAVE NOT BEEN COMPLETED PREVIOUSLY.

SIDE DATA FORMAT

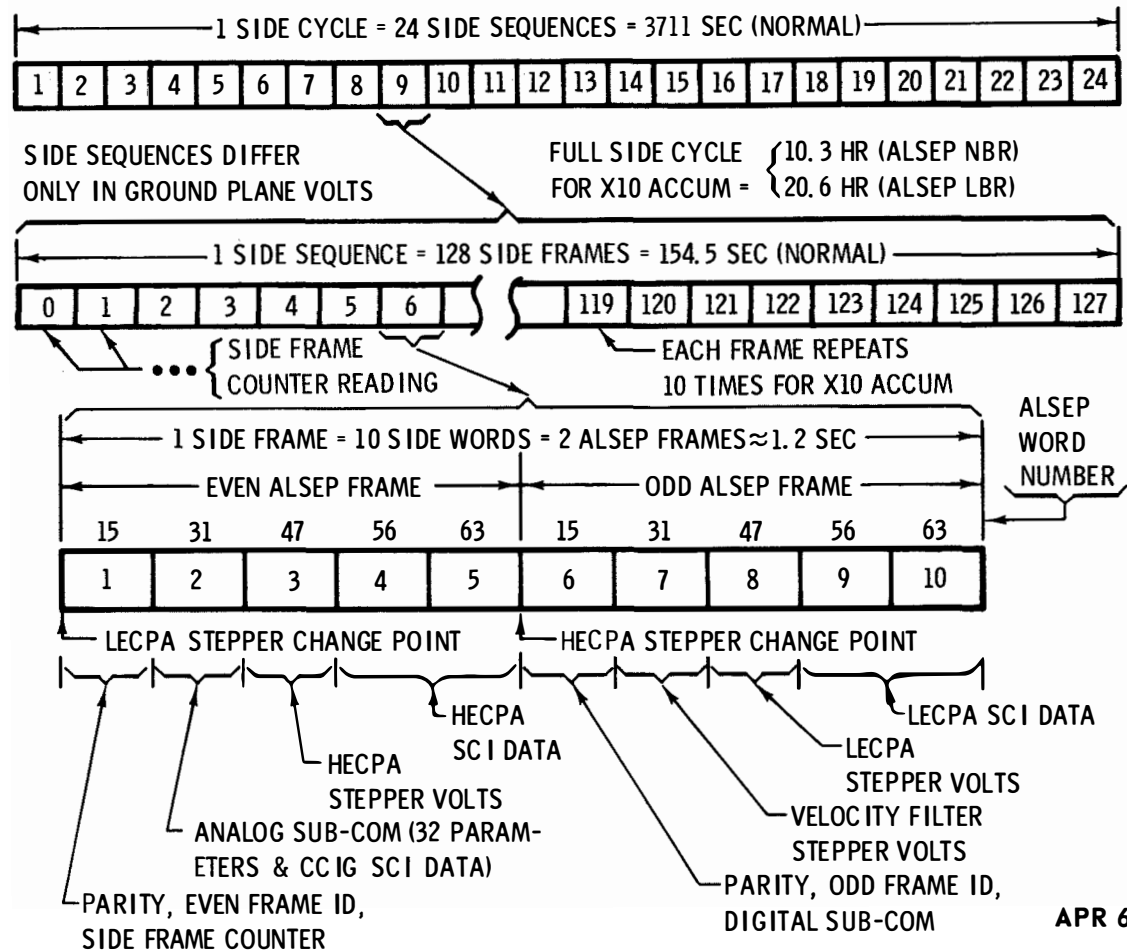

SIDE DATA MODES

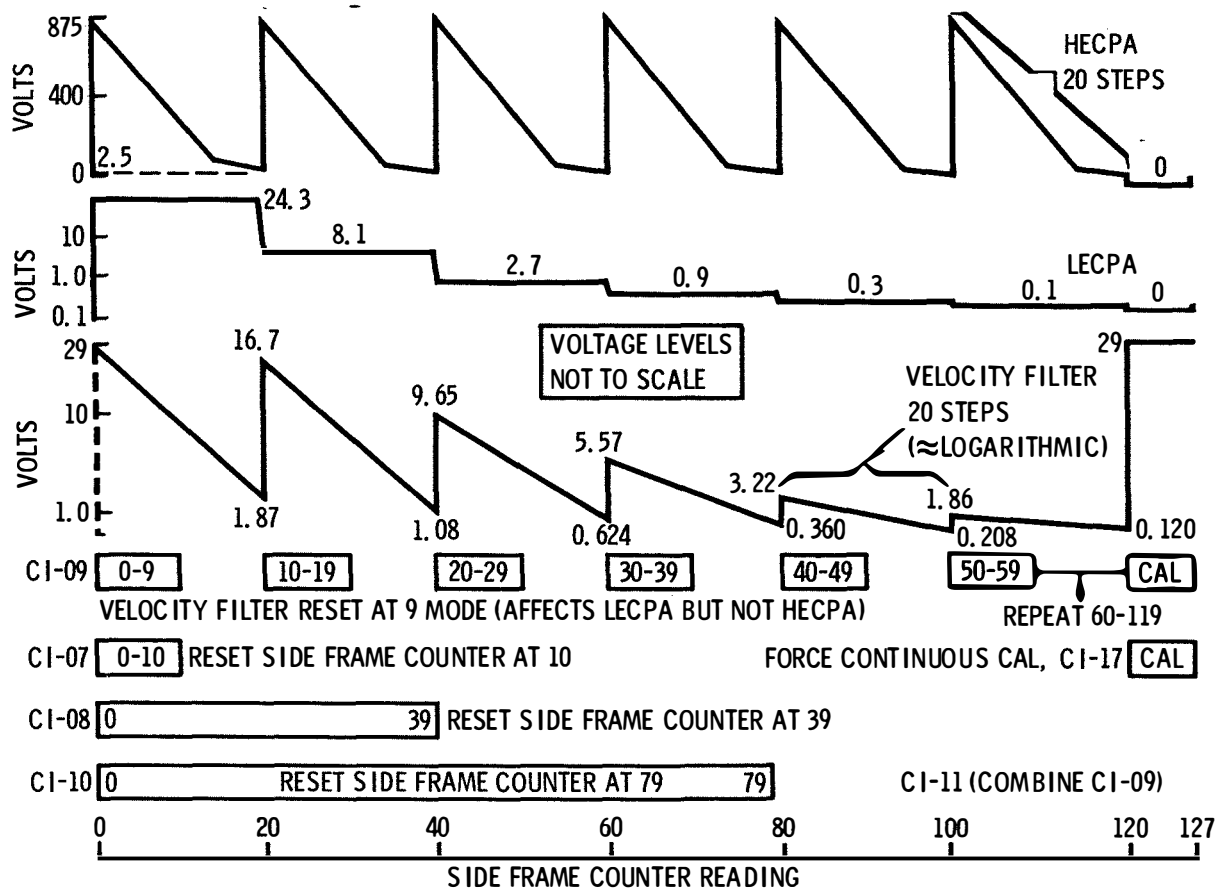

SIDE DATA WORD STRUCTURE

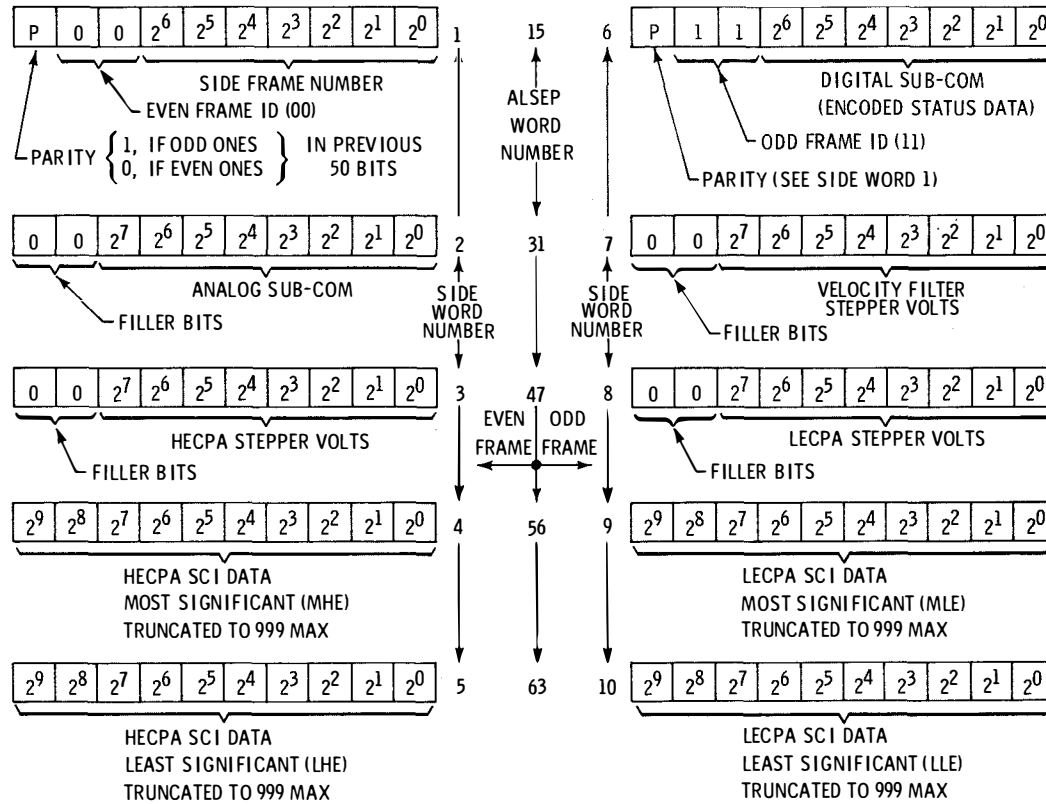

SIDE ANALOG COMMUTATION

0								7
+5V SUPPLY	CCIG SCI	CCIG TEMP	CCIG SCI	SIDE 2 TEMP	CCIG SCI	SIDE 3 TEMP	CCIG SCI	
+4.5 KV	CCIG SCI	RANGE ID	SIDE 4 TEMP	SIDE 5 TEMP	GND PLANE	SIDE CVR	GND PLANE	
+60 VOLTS	+30 VOLTS	SIDE/D +5V	GND VOLTS	-5 VOLTS	-30 VOLTS	SIDE 6 TEMP	-3.5 KV	
RANGE ID	ADC +30MV	ADC + REF	ADC +1.0V	ADC +12V	GND PLANE	ADC - REF	GND PLANE	RST AT 39
+5V SUPPLY	O/T CMD	CCIG TEMP	O/T CMD	SIDE 2 TEMP	ADC - 1.0V	SIDE 3 TEMP	ADC -12V	
+4.5 KV	CCIG SCI	RANGE ID	SIDE 4 TEMP	SIDE 5 TEMP	GND PLANE	ADC -30MV	GND PLANE	
+60 VOLTS	+30 VOLTS	SIDE/D +5V	GND VOLTS	-5 VOLTS	-30 VOLTS	SIDE 6 TEMP	-3.5 KV	
RANGE ID	ADC +30MV	ADC + REF	ADC +1.0V	ADC +12V	GND PLANE	ADC - REF	GND PLANE	
+5V SUPPLY	PRE/REG %	CCIG TEMP	CVR/SEAL	SIDE 2 TEMP	GND PLANE	SIDE 3 TEMP	CVR/SEAL	RST AT 79
+4.5 KV	CCIG SCI	RANGE ID	SIDE 4 TEMP	SIDE 5 TEMP	GND PLANE	SIDE CVR	GND PLANE	
+60 VOLTS	+30 VOLTS	SIDE/D +5V	GND VOLTS	-5 VOLTS	-30 VOLTS	SIDE 6 TEMP	-3.5 KV	
RANGE ID	ADC +30MV	ADC + REF	ADC +1.0V	ADC +12V	GND PLANE	ADC - REF	GND PLANE	
+5V SUPPLY	O/T CMD	CCIG TEMP	O/T CMD	SIDE 2 TEMP	ADC -1.0V	SIDE 3 TEMP	ADC -12V	
+4.5 KV	CCIG SCI	RANGE ID	SIDE 4 TEMP	SIDE 5 TEMP	GND PLANE	ADC -30MV	GND PLANE	
+60 VOLTS	+30 VOLTS	SIDE/D +5V	GND VOLTS	-5 VOLTS	-30 VOLTS	SIDE 6 TEMP	-3.5 KV	
RANGE ID	CCIG SCI							
120								127

SIDE DIGITAL COMMUTATION

0	GND PL ID	CMD REG	GND PL ID	MODE REG	GND PL ID	CMD REG	GND PL ID	CVR/SEAL	7
		RANGE ID						MODE REG	
		CMD REG						↓	
		RANGE ID						↓	
		CMD REG						CVR/SEAL	RST AT 39
		RANGE ID						MODE REG	
		CMD REG						↓	
		RANGE ID						↓	
		CMD REG						CVR/SEAL	RST AT 79
		RANGE ID						MODE REG	
		CMD REG						↓	
		RANGE ID						↓	
		CMD REG						CVR/SEAL	
		RANGE ID						MODE REG	
		CMD REG						↓	
120	CAL RT1 ID	CAL RT2 ID	CAL RT3 ID	CAL RT4 ID	CAL RT1 ID		CAL RT3 ID	CAL RT4 ID	127

SIDE DATA SUMMARY

DI-01	SIDE FRAME CNTR	DI-17	SIDE -5V SUPPLY	DI-40	} HECPA STEP VOLTS	DI-72	} SIDE V/FILT VOLTS
DI-02	SIDE/A +5V SUPPLY	DI-18	SIDE -30V SUPPLY	through		DI-72	
DI-03	CCGE SCI DATA	DI-19	SIDE 6 DEG C	DI-60	} SIDE/MHE SCI CNTS	DI-99	} LECPA STEP VOLTS
DI-04	SIDE CC 1G DEG C	DI-20	SIDE 3.5 KV SUPPLY	DI-61		DI-99	
DI-05	SIDE 2 DEG C	DI-21	SIDE ADC +1.0V	DI-62	SIDE/LHE SCI CNTS	DJ-00	} LECPA STEP VOLTS
DI-06	SIDE 3 DEG C	DI-22	SIDE ADC +30 MV	DI-63	GND PL STEP ID	DJ-97	
DI-07	CCGE 4.5KV SUPPLY	DI-23	SIDE ADC POS REF	DI-64	SIDE CMD REG LOAD	DJ-98	} LECPA STEP VOLTS
DI-08	CCGE/A RANGE ID	DI-24	SIDE/A CVR/S STA	DI-65	SIDE MODE REG STA	DJ-99	
DI-09	SIDE 4 DEG C	DI-25	SIDE ADC NEG REF	DI-66	SIDE/D CVR/S STA	DF-00	} LECPA STEP VOLTS
DI-10	SIDE 5 DEG C	DI-26	SIDE ADC -1.0V	DI-67	CCGE/D RANGE ID	through	
DI-11	GND PLANE VOLTS	DI-27	SIDE ADC -12V	DI-68	SIDE CAL RT 1 ID	DF-04	} SIDE/MLE SCI CNTS
DI-12	SIDE CVR CELL IND	DI-28	SIDE ADC +12V	DI-69	SIDE CAL RT 2 ID	DF-05	
DI-13	SIDE +60V SUPPLY	DI-29	SIDE PRE/REG PCT	DI-70	SIDE CAL RT 3 ID	DF-06	} SIDE/LLE SCI CNTS
DI-14	SIDE +30V SUPPLY	DI-30	SIDE ADC -30MV	DI-71	SIDE CAL RT 4 ID	DF-07	
DI-15	SIDE/D +5V SUPPLY	DF-29	SIDE O/T CMD LOAD			DF-08	SIDE FRAME ID
DI-16	SIDE GND VOLTS						

DIGITAL "FILL" DATA

STBY, ALL ZEROS
OFF, ALL ONES

A1-01 SIDE/LE CNT RT
A1-02 SIDE/HE CNT RT

APR 69 5178.12.29

HEAT FLOW EXPERIMENT

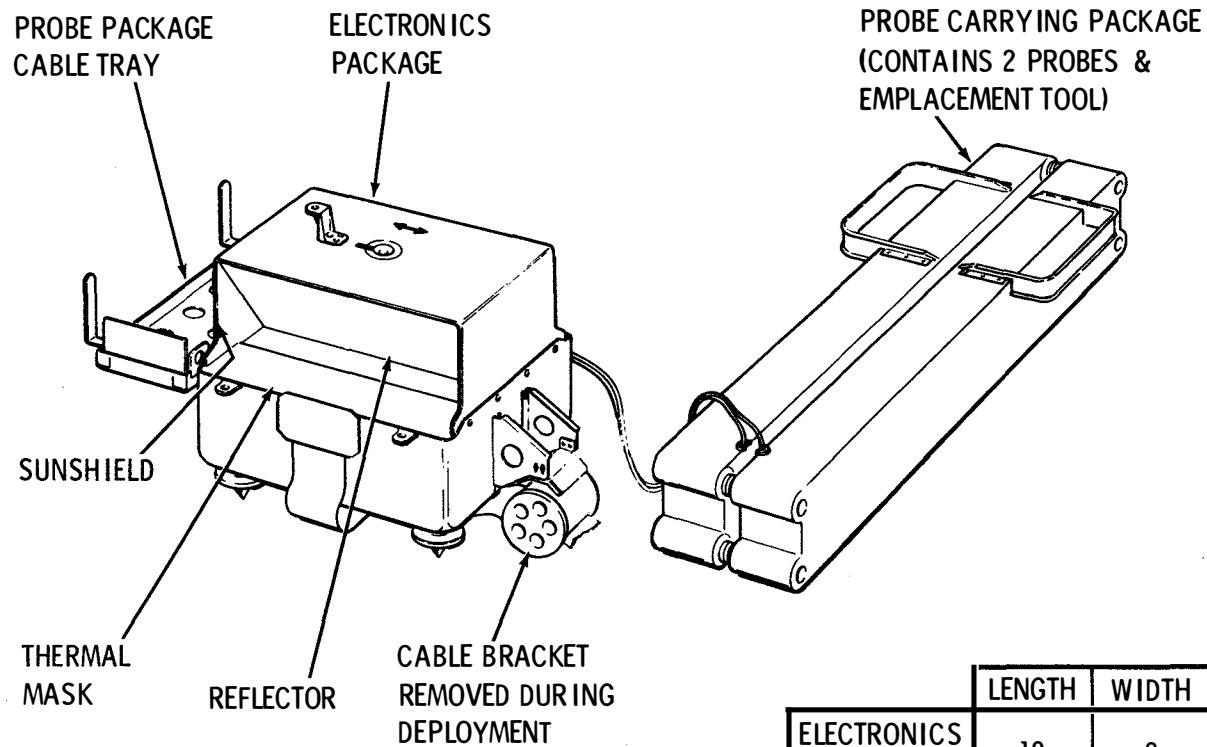

	LENGTH	WIDTH	HEIGHT
ELECTRONICS PACKAGE	10	8	7.5
PROBE PACKAGE	25.5	3.5	5

- COMPONENTS & FUNCTIONS

- DEPLOYMENT

- COMMANDS & DATA

APR 69 5178.13.1

HFE SIZE AND WEIGHT

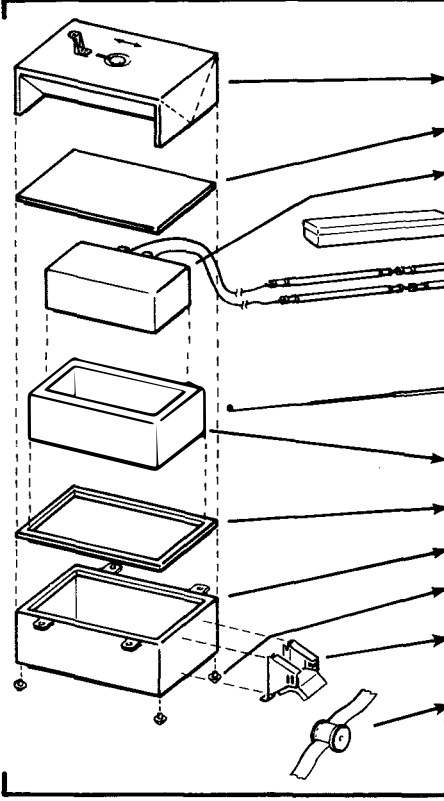

COMPONENT	SIZE, IN.	EARTH WT, LB
SUNSHIELD	10 x 6 x 4	.37
THERMAL PLATE	10 x 8 x 0.08	.40
ELECTRONICS	9 x 7 x 2.07	3.30
PROBE PACKAGE	25.5 X 4.5 X 3.5	3.67
PROBES (2), EACH	1 DIA x 43 LONG	
EMPLACEMENT TOOL (FULLY EXTENDED)	88 LONG	
THERMAL BAG	9.5 x 7.5 x 2.57	.30
INSULATING RING	10 x 8 x 0.4	.57
OUTER CASE	10 x 8 x 3.5	.46
LEGS (4)	0.75 x 0.75	.16
CABLE REEL SUPPORT, ETC.		.23
CABLE REEL	2.57 DIA x 2.6 LONG	.16
SCREWS, WASHERS, ETC.		.08
TOTAL		9.70

APR 69 5178.13.2

HFE PROBE DETAILS

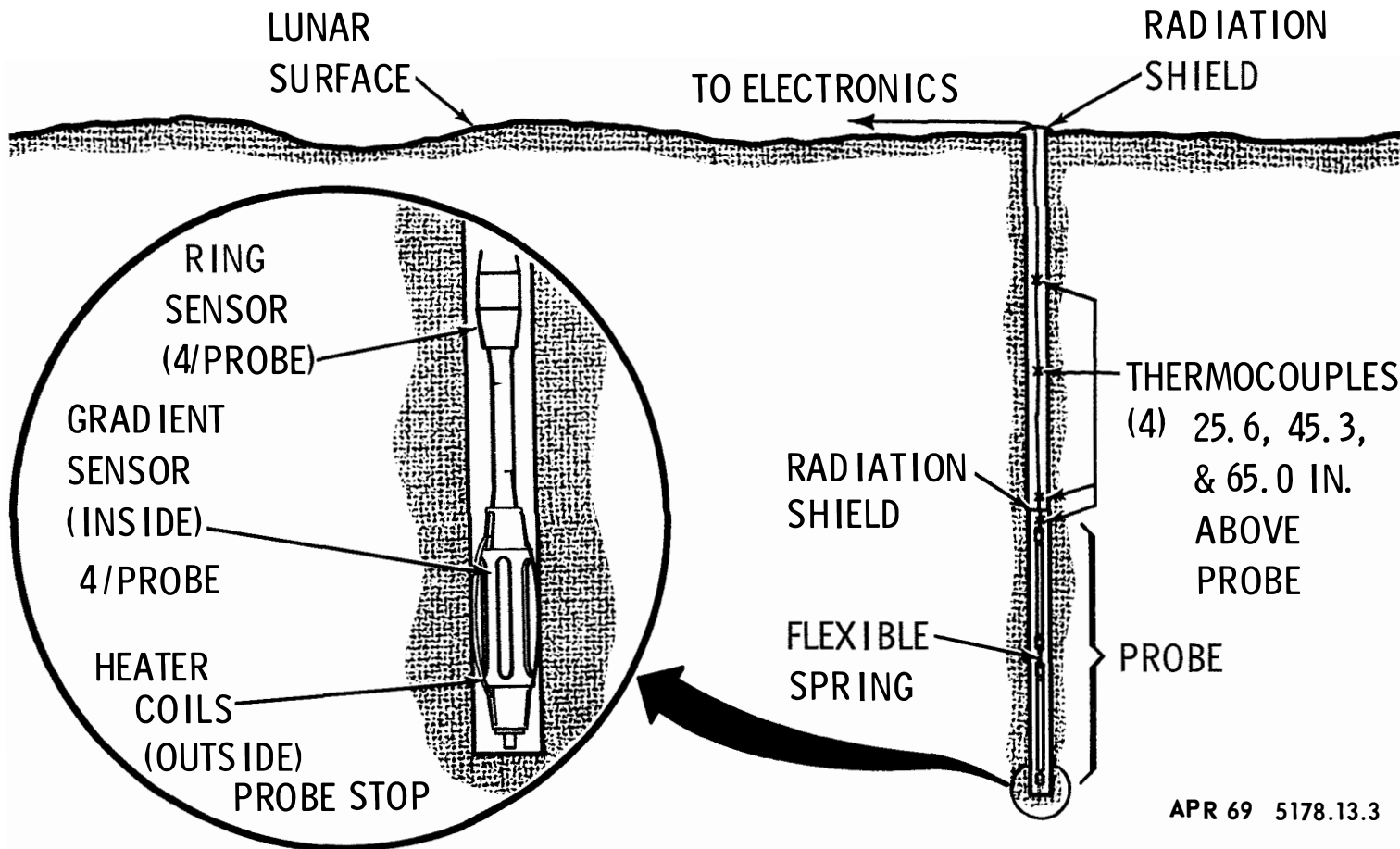

HFE FUNCTIONAL DIAGRAM

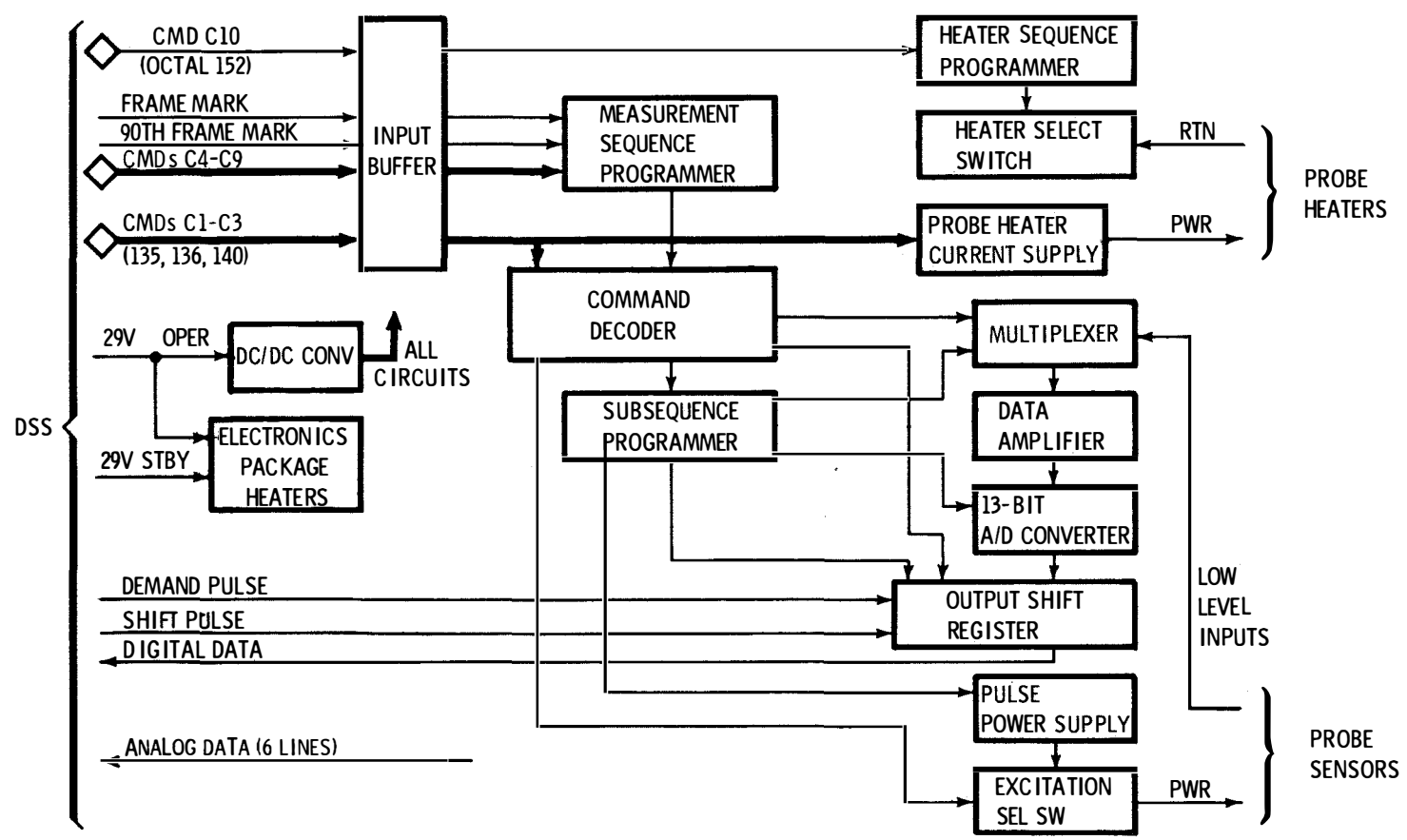

HFE MODES OF OPERATION

		MODE		
		G, NORMAL GRADIENT (MODE 1)	LK, LOW CONDUCTIVITY (MODE 2)	HK, HIGH CONDUCTIVITY (MODE 3)
MEASURE- MENT SEQUENCES	A. FULL (ALL MEAS)	SAME AS GRADIENT	DIFFERENTIAL & AMBIENT TEMP FOR ONE BRIDGE (DEPENDING ON SELECTED HEATER)	
	B. PROBE 1 PROBE 2			
	C.* { DIFFERENTIAL TEMP (HI EXCITATION) DIFFERENTIAL TEMP (LO EXCITATION) AMBIENT TEMP REF JUNCTION TEMP & CABLE THERMOCOUPLES			
	D. COMBINATIONS OF B & C			
BRIDGE SENSORS	GRADIENT	GRADIENT	RING (OR "REMOTE")	
HEATERS	NONE	RING SOURCE	HEAT PULSE	

*THESE MODES
USED PRIMARILY
FOR TESTS

HFE COMMAND SUMMARY

<u>CMD</u>	<u>NUMBERS</u>		
<u>HFE</u>	<u>OCTAL</u>		
C1	135	HFE MODE/G SEL*	INITIALIZED TO THESE CONDITIONS AT POWER TURN-ON
C2	136	HFE MODE/LK SEL	
C3	140	HFE MODE/HK SEL	
C4	141	HFE SEQ/FUL SEL*	
C5	142	HFE SEQ/P1 SEL	
C6	143	HFE SEQ/P2 SEL	
C7	144	HFE LOAD 1	MEASUREMENT SELECT (ENCODED)
C8	145	HFE LOAD 2	
C9	146	HFE LOAD 3	
C10	152	HFE HTR STEPS	

INPUT BUFFER HOLDS COMMANDS FOR EXECUTION AT 90-FRAME MARK

HFE DIGITAL DATA FORMAT

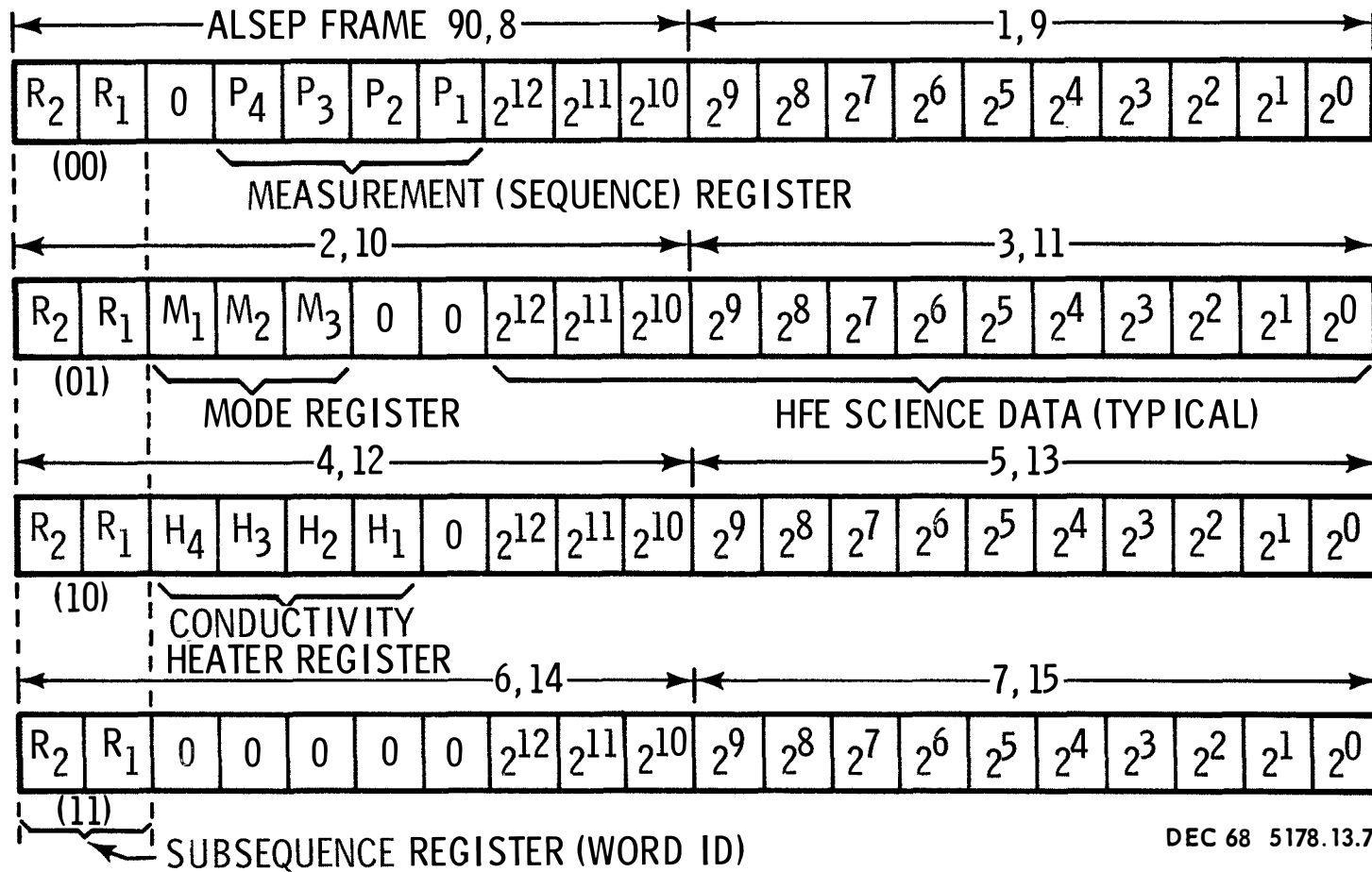

HFE MODE REGISTER

THE MODE REGISTER IS PART OF THE HFE CMD DECODER AND RESPONDS TO CMDs 135, 136 AND 140. THE STATE OF THIS REGISTER IS READ OUT VIA TM

<u>OCTAL</u>	<u>ABBR</u>	<u>HFE</u>	<u>MODE</u>	<u>TM (M₁M₂M₃)</u>
135	MODE/G	MODE 1	NORMAL GRADIENT	100
136	MODE/LK	MODE 2	LOW CONDUCTIVITY	010
140	MODE/HK	MODE 3	HIGH CONDUCTIVITY	001

THE MODE SELECTED BY CMD AFFECTS THE DATA AS FOLLOWS:

MODE/G AND MODE/LK HAVE IDENTICAL TM (FORMATTED BY THE MEASUREMENT SEQUENCE PROGRAMMER AND SUBSEQUENCE PROGRAMMER) BUT IN MODE/LK THE PROBE HEATER CURRENT SUPPLY IS TURNED ON AND HEATERS RESPOND TO CMD 152.

MODE/HK BYPASSES THE MEASUREMENT SEQUENCE PROGRAMMER AND PRODUCES A SPECIAL TM OUTPUT FORMATTED BY THE SUBSEQUENCE PROGRAMMER AND HEATER SEQUENCE PROGRAMMER.

HFE GRADIENT MEASUREMENT OPTIONS

CMDs & ORDER (OCTAL)	135	135	135	135	135	135	135	135	135	135	135	135	135	135	135
	141	141	141	141	141	142	142	142	142	142	143	143	143	143	143
	-	144	144	-	144	-	144	144	-	144	-	144	144	-	144
	-	-	145	145	-	-	-	145	145	-	-	-	145	145	-
	-	-		146	146	-	-	-	146	146	-	-	-	146	146
GDT11H GDT12H	NOTE: GRADIENT MODE SHOWN														
GDT21H GDT22H	<div style="display: flex; justify-content: space-between;"> <div style="width: 15%;">HI ONLY</div> <div style="width: 30%;">180 FRAME REP RATE</div> <div style="width: 30%;">HFE SEQ/P1</div> <div style="width: 15%;">HFE SEQ/P2</div> </div>														
GDT11L GDT12L	<div style="display: flex; justify-content: space-between;"> <div style="width: 15%;">LO ONLY</div> <div style="width: 30%;"></div> <div style="width: 30%;"></div> <div style="width: 15%;"></div> </div>														
GDT21L GDT22L	<div style="display: flex; justify-content: space-between;"> <div style="width: 15%;">HFE-SEQ/FULL</div> <div style="width: 15%;">LO ONLY</div> <div style="width: 30%;"></div> <div style="width: 15%;"></div> </div>														
GT11 GT12	<div style="display: flex; justify-content: space-between;"> <div style="width: 15%;">HFE-SEQ/FULL</div> <div style="width: 15%;">AMB ONLY</div> <div style="width: 30%;">16 OUT OF 90 FRAMES</div> <div style="width: 15%;"></div> </div>														
GT21 GT22	<div style="display: flex; justify-content: space-between;"> <div style="width: 15%;"></div> <div style="width: 15%;">AMB ONLY</div> <div style="width: 30%;">360 FRAME REP RATE</div> <div style="width: 15%;">90 FRAME REP RATE</div> </div>														
REF T1 TC1A, B, C, D	<div style="display: flex; justify-content: space-between;"> <div style="width: 15%;">720 FRAME REP RATE</div> <div style="width: 15%;">TC & REF</div> <div style="width: 30%;"></div> <div style="width: 15%;"></div> </div>														
REF T2 TC2A, B, C, D	<div style="display: flex; justify-content: space-between;"> <div style="width: 15%;">720 FRAME REP RATE</div> <div style="width: 15%;">TC & REF</div> <div style="width: 30%;"></div> <div style="width: 15%;"></div> </div>														

HFE MEASUREMENT SEQUENCE PROGRAMMER

THE MEASUREMENT SEQUENCE PROGRAMMER (MSP) IS A 16-STATE BINARY COUNTER USING 4 FLIP-FLOPS. ITS OPERATION CAN BE MODIFIED BY CMD TO PERFORM 8-STATE, 4-STATE, AND 2-STATE PROGRAMS. THE FLIP-FLOPS HAVE DUAL FUNCTIONS:

- FORMAT HFE DATA BY CONTROLLING GATES TO THE OUTPUT REGISTER
- SUPPLY MSP STATUS DATA FOR TM (P-BITS)

NOTE THAT EXECUTION OF A MEASUREMENT CMD (141 THROUGH 146) DOES NOT RESET MSP. OPERATION CONTINUES FROM PREVIOUS STATE.

IN DIAGRAM, THE SET (S) AND CLEAR (C) POSITIONS OF THE FLIP-FLOPS CORRESPOND TO ONE AND ZERO IN THE TM.

HFE MSP DIAGRAM

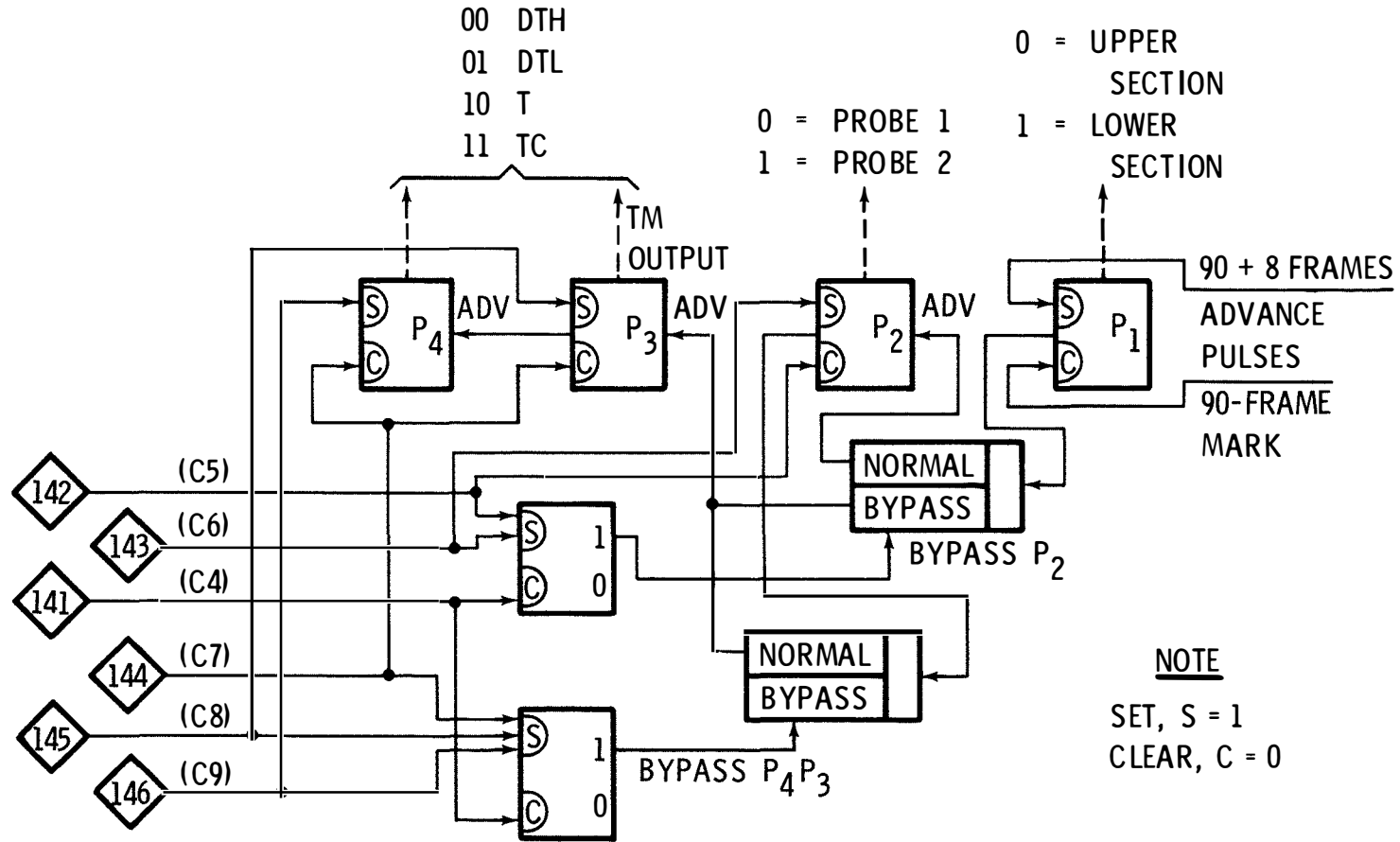

APR 69 5178.13.11

HFE SUBSEQUENCE PROGRAMMER

THE SUBSEQUENCE PROGRAMMER IS A 4-STATE COUNTER HAVING DUAL FUNCTIONS:

- CONTROL GATING OF DATA, WITHIN A SUBSET, TO THE OUTPUT REGISTER: (WHERE THE TYPE OF SUBSET IS CONTROLLED BY THE MSP)
- SUPPLY SUBSEQUENCE REGISTER STATUS DATA FOR TM (R-BITS)

THE STATE OF $R_2 R_1$ CHANGES EVERY OTHER ALSEP FRAME (ONE 10-BIT WORD OF HFE DATA IN EACH ALSEP FRAME) STARTING WITH A RESET AT THE 90-FRAME MARK

THE TRANSITION FROM 11 TO 00 BETWEEN 7 AND 8 MARKS THE 90 + 8 FRAME. THIS ADVANCES P_1 FROM ZERO TO ONE

$R_2 R_1$	ALSEP	FRAME NO
00	90,1	8,9
01	2,3	10,11
10	4,5	12,13
11	6,7	14,15

$R_2 R_1$ READ OUT AS FIRST TWO BITS IN EVEN NUMBERED ALSEP FRAME

FROM ALSEP FRAME 16 TO 89 THERE IS NO HFE DATA AND REGISTER CHANGES ARE INHIBITED

HFE TIMING FUNCTIONS

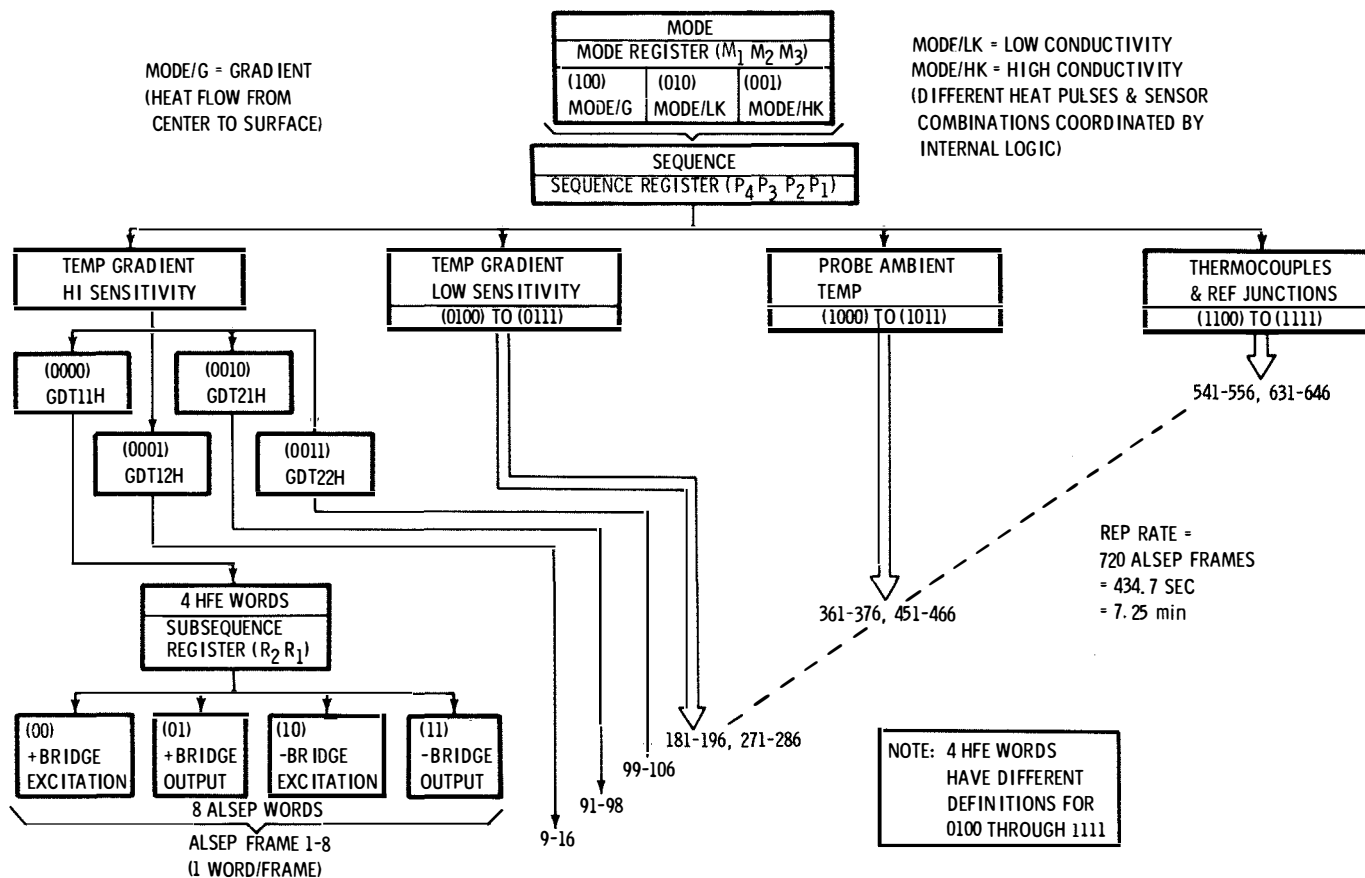

HFE GRADIENT MEASUREMENT INDEX

SYMBOL	ABBR	P-BITS	DATA SOURCE	PROBE/ BRIDGE	EXCITATION (SENSITIVITY)	(R ₂ R ₁) SUBSET DATA			
DH-01 DH-02 DH-03 DH-04	GDT 11H GDT 12H GDT 21H GDT 22H	0000 0001 0010 0011	DIFFERENTIAL	1/UPPER 1/LOWER	HIGH VOLTAGE	(00) + BRIDGE EXCITATION (01) + BRIDGE OUTPUT			
				2/UPPER 2/LOWER		(10) - BRIDGE EXCITATION (11) - BRIDGE OUTPUT			
DH-05 DH-06 DH-07 DH-08	GDT 11L GDT 12L GDT 21L GDT 22L	0100 0101 0110 0111	BRIDGE (GRADIENT SENSORS)	1/UPPER 1/LOWER	LOW VOLTAGE	(00) + BRIDGE CURRENT (01) + BRIDGE OUTPUT			
				2/UPPER 2/LOWER		(10) - BRIDGE CURRENT (11) - BRIDGE OUTPUT			
DH-09 DH-10 DH-11 DH-12	GT 11 GT 12 GT 21 GT 22	1000 1001 1010 1011	(RESIS- TANCE)	1/UPPER 1/LOWER	HIGH VOLTAGE	(00) + BRIDGE EXCITATION (01) + BRIDGE CURRENT			
				2/UPPER 2/LOWER		(10) - BRIDGE EXCITATION (11) - BRIDGE CURRENT			
DH-13	REF T1	1100	REF JUNCTION BR		HV	SAME AS DH-01 TO DH-04			
DH-14 DH-24 DH-34 DH-44	TC1 GROUP	1101	THERMOCOUPLES IN CABLE OF PROBE 1 WRT REF T1			(00) REF T1-TC1 (4) (1) IS AT (01) TC1 (4)-TC1 (1) TOP AND (10) TC1 (4)-TC1 (2) (4) IS AT (11) TC1 (4)-TC1 (3) BOTTOM			
DH-15				REF T2	1110	SAME AS DH-13	HV	SAME AS DH-01 TO DH-04	
DH-16 DH-26 DH-46 DH-66				TC2 GROUP	1111	THERMOCOUPLES IN CABLE OF PROBE 2 WRT REF T2			(00) REF T2-TC2 (4) (1) IS AT (01) TC2 (4)-TC2 (1) TOP AND (10) TC2 (4)-TC2 (2) (4) IS AT (11) TC2 (4)-TC2 (3) BOTTOM

HFE HEATER SEQUENCE PROGRAMMER

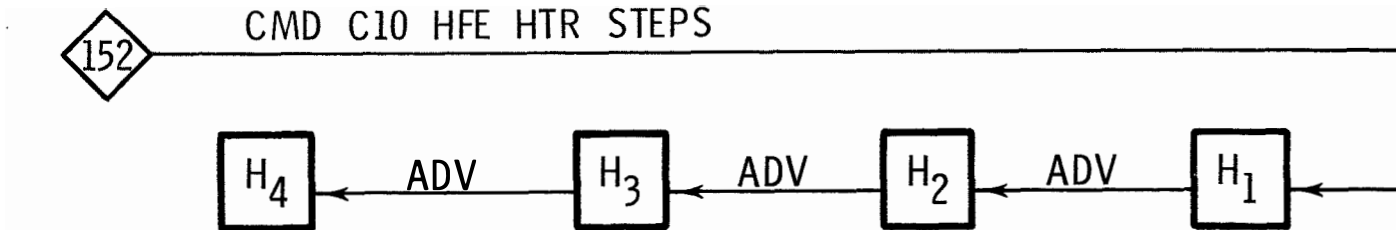

- 16-STATE BINARY COUNTER USING 4 FLIP-FLOPS
- STATUS TRANSMITTED IN TM AS H-BITS (ALL 3 MODES)
- EFFECT ON OPERATION AND DATA:
 - MODE/G – NO EFFECT (CAN BE ADVANCED VIA CMD 152 BUT PROBE HEATER CURRENT SUPPLY IS OFF)
 - MODE/LK – CONTROLS ON/OFF STATUS OF 8 HEATERS (4/PROBE) IN LOW MODE OF PROBE HEATER CURRENT SUPPLY
 - MODE/HK – CONTROLS DATA OUTPUT AND ON/OFF STATUS OF 8 HEATERS IN HIGH MODE OF PROBE HEATER CURRENT SUPPLY
- PROBE HEATER ON/OFF STATUS IN ANALOG TM (ALSEP WORD 33)

HFE HEATER SELECT CODE

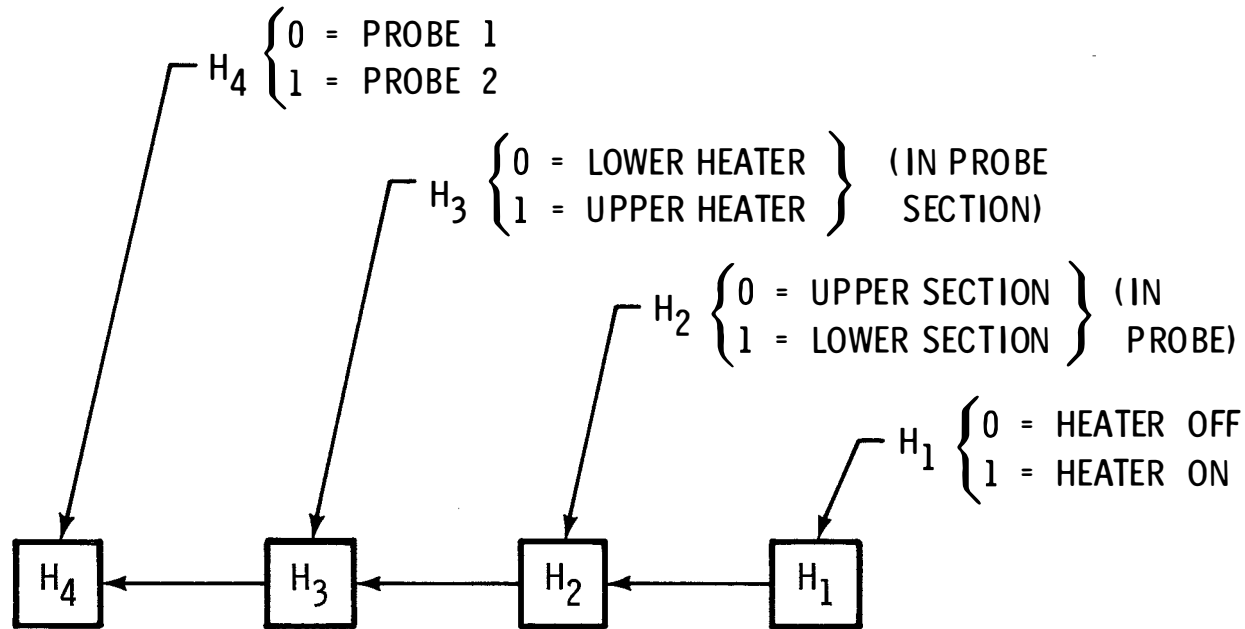

H ₃ H ₂	HTR NUMBER
00	2
01	4 (BOTTOM)
10	1 (TOP)
11	3

EXAMPLE: WHEN H-BITS = 1011,
HEATER H24 IS ON (WHERE
H24 INDICATES FOURTH
HEATER IN PROBE 2)

NOTE: THIS CODE APPLIES TO HEATER CONTROL
IN BOTH MODE/LK AND MODE/HK

DEC 68 5178.13.16

HFE MEASUREMENTS IN MODE/HK

SYMBOL	ABBR	PROBE	BRIDGE	H ₄ H ₃ H ₂ H ₁	SYMBOL	ABBR	PROBE	BRIDGE	H ₄ H ₃ H ₂ H ₁
DH-50	RDT 11	1	1	0000	DH-70	RDT 21	2	1	1000
DH-51	RT 11	1	1	0000	DH-71	RT 21	2	1	1000
DH-52	RDT 11	1	1	0001	DH-72	RDT 21	2	1	1001
DH-53	RT 11	1	1	0001	DH-73	RT 21	2	1	1001
DH-60	RDT 12	1	2	0010	DH-80	RDT 22	2	2	1010
DH-61	RT 12	1	2	0010	DH-81	RT 22	2	2	1010
DH-62	RDT 12	1	2	0011	DH-82	RDT 22	2	2	1011
DH-63	RT 12	1	2	0011	DH-83	RT 22	2	2	1011
DH-56	RDT 11	1	1	0100	DH-76	RDT 21	2	1	1100
DH-57	RT 11	1	1	0100	DH-77	RT 21	2	1	1100
DH-58	RDT 11	1	1	0101	DH-78	RDT 21	2	1	1101
DH-59	RT 11	1	1	0101	DH-79	RT 21	2	1	1101
DH-66	RDT 12	1	2	0110	DH-86	RDT 22	2	2	1110
DH-67	RT 12	1	2	0110	DH-87	RT 22	2	2	1110
DH-68	RDT 12	1	2	0111	DH-88	RDT 22	2	2	1111
DH-69	RT 12	1	2	0111	DH-89	RT 22	2	2	1111

- DATA ALTERNATES BETWEEN DIFFERENCE (BRIDGE) AND AMBIENT (RESISTANCE) MEASUREMENTS FOR THE SET OF RING SENSORS NEAREST THE SELECTED HEATER

ALSEP FRAMES	P ₁ (a)	MEAS TYPE (b)	ABBR (c)
90 TO 7	0	DIFFERENCE	RDTNN
8 TO 15	1	AMBIENT	RTNN

- NOTES

(a) P-BITS, OTHER THAN P₁, ARE MEANINGLESS IN MODE/HK

(b) MEASUREMENT CONTENT:

R ₂ R ₁	DIFFERENCE	AMBIENT
00	+ BRIDGE EXCITATION VOLTS	
01	+ BRIDGE OUTPUT	+ BRIDGE CURRENT
10	- BRIDGE EXCITATION VOLTS	
11	- BRIDGE OUTPUT	- BRIDGE CURRENT

(c) NN IDENTIFIES SENSOR (BRIDGE) LOCATION

DEC 68 5178.13.17

HFE COMMAND DETAILS

LOCAL CMD NUMBER

135 HFE MODE/G SEL

THIS CMD (C1) IS A 1-STATE CMD. IT PLACES THE HFE IN THE GRADIENT, OR NORMAL, MODE OF OPERATION IN WHICH MEASUREMENTS ARE OBTAINED FROM THE GRADIENT SENSORS AND CABLE THERMOCOUPLES UNDER THE CONTROL OF THE MSP. CMD 135 ALSO TURNS OFF THE PROBE HEATER CURRENT SUPPLY. DIFFERENT MEASUREMENT SEQUENCES IN MODE/G MAY BE SELECTED BY TRANSMITTING SUBSEQUENT CMDs. AT POWER TURN-ON, THE HFE INITIALIZES IN MODE/G. IF THE HFE IS IN MODE/G, TRANSMISSION OF CMD 135 HAS NO EFFECT.

NOTE THAT THE HFE INPUT BUFFER HOLDS CMDs FOR EXECUTION AT THE 90-FRAME MARK; THUS, SEQUENTIAL CMDs MUST BE TRANSMITTED AT LEAST 54 SEC APART.

136 HFE MODE/LK SEL

THIS CMD (C2) IS A 1-STATE CMD. IT PLACES THE HFE IN THE LOW CONDUCTIVITY, OR RING SOURCE, MODE OF OPERATION IN WHICH MEASUREMENTS, AND SEQUENCES, ARE IDENTICAL TO MODE/G. IT ALSO TURNS ON THE PROBE HEATER CURRENT SUPPLY IN THE LOW (RING SOURCE) MODE ALLOWING HEATERS TO BE ACTIVATED BY CMD 152. IF THE HFE IS IN MODE/LK, TRANSMISSION OF CMD 136 HAS NO EFFECT.

140 HFE MODE/HK SEL

THIS CMD (C3) IS A 1-STATE CMD. IT PLACES THE HFE IN THE HIGH CONDUCTIVITY, OR HEAT PULSE, MODE OF OPERATION IN WHICH MEASUREMENTS ARE OBTAINED FROM THE RING (OR REMOTE) SENSORS UNDER THE CONTROL OF THE HEATER SEQUENCE PROGRAMMER. NOTE THAT CMD 144 (C7) MUST ALSO BE TRANSMITTED BEFORE VALID DATA WILL BE OBTAINED IN MODE/HK. EITHER CMD MAY BE TRANSMITTED FIRST. CMD 140 ALSO TURNS ON THE PROBE HEATER CURRENT SUPPLY IN THE HIGH, OR HEAT PULSE, MODE ALLOWING HEATERS TO BE ACTIVATED BY CMD 152. IF THE HFE IS IN MODE/HK, TRANSMISSION OF CMD 140 HAS NO EFFECT.

141 HFE SEQ/FUL SEL

THIS CMD (C4) IS A 1-STATE CMD. IT CANCELS THE EFFECT OF CMDs 142 THROUGH 146 CAUSING THE MSP TO PERFORM ITS FULL 16-STATE CYCLE OF OPERATION IN MODE/G OR MODE/LK. IF TRANSMITTED DURING MODE/HK OPERATION, THIS CMD WILL CAUSE INVALID OPERATION UNTIL CMD 144 IS EXECUTED. AT POWER TURN-ON, THE HFE INITIALIZES IN SEQ/FUL. IF THE HFE IS IN MODE/G OR MODE/LK AND IN SEQ/FUL, TRANSMISSION OF CMD 141 HAS NO EFFECT.

142 HFE SEQ/P1 SEL

THIS CMD (C5) IS A 1-STATE CMD AND ALTERNATES WITH CMD 143 TO SELECT ONLY ONE PROBE FOR MEASUREMENT. IN MODE/HK THIS CMD IS MEANINGLESS. IN MODE/G AND MODE/LK IT CAUSES THE MSP TO LOCK FLIP-FLOP P₂ IN THE CLEAR STATE AND BYPASS P₂. THUS THE MSP ACTS AS AN 8-STATE COUNTER IF CMD 141 WAS PREVIOUSLY EXECUTED, OR AS A 2-STATE COUNTER IF CMD 144, 145 OR 146 WAS PREVIOUSLY EXECUTED. SEQ/P1 IS CLEARED BY SUBSEQUENT EXECUTION OF CMD 141.

143 HFE SEQ/P2 SEL

THIS CMD (C6) IS A 1-STATE CMD AND ALTERNATES WITH CMD 142 TO SELECT ONLY ONE PROBE FOR MEASUREMENT. IT HAS THE SAME CHARACTERISTICS AS CMD 142 EXCEPT THAT FLIP-FLOP P₂ IS LOCKED IN THE SET STATE.

144 HFE LOAD 1

THIS CMD (C7) IS A 1-STATE CMD AND IS USED ALONE OR IN COMBINATION WITH CMD 145 OR 146 TO POSITION AND LOCK TWO FLIP-FLOPS (P₄ P₃) OF THE MSP. CMD 144 PLACES P₄ P₃ IN THE CLEAR POSITION (00) AND BYPASSES THOSE STEPS. THE MSP THEN ACTS AS A 4-STATE COUNTER IF CMD 141 WAS PREVIOUSLY EXECUTED AND AS A 2-STATE COUNTER IF CMD 142 OR 143 WAS PREVIOUSLY EXECUTED. THIS APPLIES TO MODE/G AND MODE/LK. IN MODE/HK CMD 144 MUST BE EXECUTED TO OBTAIN VALID DATA. CMDs 145 OR 146 MAY BE USED IN MODE/G OR MODE/LK, FOLLOWING CMD 144, TO LOCK P₄ P₃ IN THE 10 OR 01 STATE RESPECTIVELY. THE EFFECT OF CMD 144 IS CLEARED BY SUBSEQUENT EXECUTION OF CMD 141. NOTE: WHEN IN MODE/G OR MODE/LK 00 STATE PROVIDES HIGH EXCITATION DIFFERENTIAL TEMPERATURE DATA ONLY.

145 HFE LOAD 2

THIS CMD (C8) IS A 1-STATE CMD AND IS USED IN COMBINATION WITH EITHER CMD 144 (PRECEDING 145) OR CMD 146 (PRECEDING OR FOLLOWING 145) TO POSITION AND LOCK P₄ P₃ (SEE CMD 144). CMD 145 POSITIONS FLIP-FLOP P₃ IN THE SET STATE. THEREFORE, 144-145 YIELDS 01 (LOW EXCITATION DIFFERENTIAL TEMPERATURE DATA ONLY) WHILE 145-146 YIELDS 11 (CABLE THERMOCOUPLE DATA ONLY). EXECUTION OF THIS CMD IN MODE/HK CAUSES INVALID DATA UNTIL CMD 144 IS EXECUTED. THE EFFECT OF CMD 145 IS CLEARED BY SUBSEQUENT EXECUTION OF CMD 141.

146 HFE LOAD 3

THIS CMD (C9) IS A 1-STATE CMD OPERATING ESSENTIALLY THE SAME AS CMD 145 EXCEPT THAT IT POSITIONS FLIP-FLOP P₄ IN THE SET STATE. WHEN PRECEDED BY CMD 144 IT YIELDS 10 FOR P₄ P₃ (AMBIENT TEMPERATURE DATA ONLY). EXECUTION OF THIS CMD IN MODE/HK CAUSES INVALID DATA UNTIL CMD 144 IS EXECUTED.

152 HFE HTR STEPS

THIS CMD (C10) IS A 16-STATE CMD WHICH ADVANCES THE HEATER EXCITATION PROGRAMMER (H₄ H₃ H₂ H₁) EACH TIME THE CMD IS EXECUTED. IN MODE/G THE PROGRAMMER ADVANCES BUT THERE IS NO OTHER EFFECT SINCE THE PROBE HEATER CURRENT SUPPLY IS OFF. IN MODE/LK THE EXECUTION OF CMD 152 ALTERNATES THE HEATER STATUS BETWEEN ON AND OFF, SIMULTANEOUSLY STEPPING THROUGH THE 8 HEATERS (CURRENT SUPPLY IS ON FULL TIME AND HEATER ELEMENTS ARE SWITCHED IN AND OUT OF CIRCUIT). IN MODE/HK THE HEATER EXCITATION PROGRAMMER (ADVANCED BY CMD 152) ALSO SELECTS THE DATA TO BE SAMPLED.

HFE ANALOG DATA

AH-01	HFE +5V SUPPLY
AH-02	HFE -5V SUPPLY
AH-03	HFE +15V SUPPLY
AH-04	HFE -15V SUPPLY
AH-05	(DELETED)
AH-06	HFE HTR/LK ON/OFF
AH-07	HFE HTR/HK ON/OFF



EACH SAMPLED ONCE
EVERY 54 SEC ALSEP
SEQUENCE

HFE THERMAL CONTROL

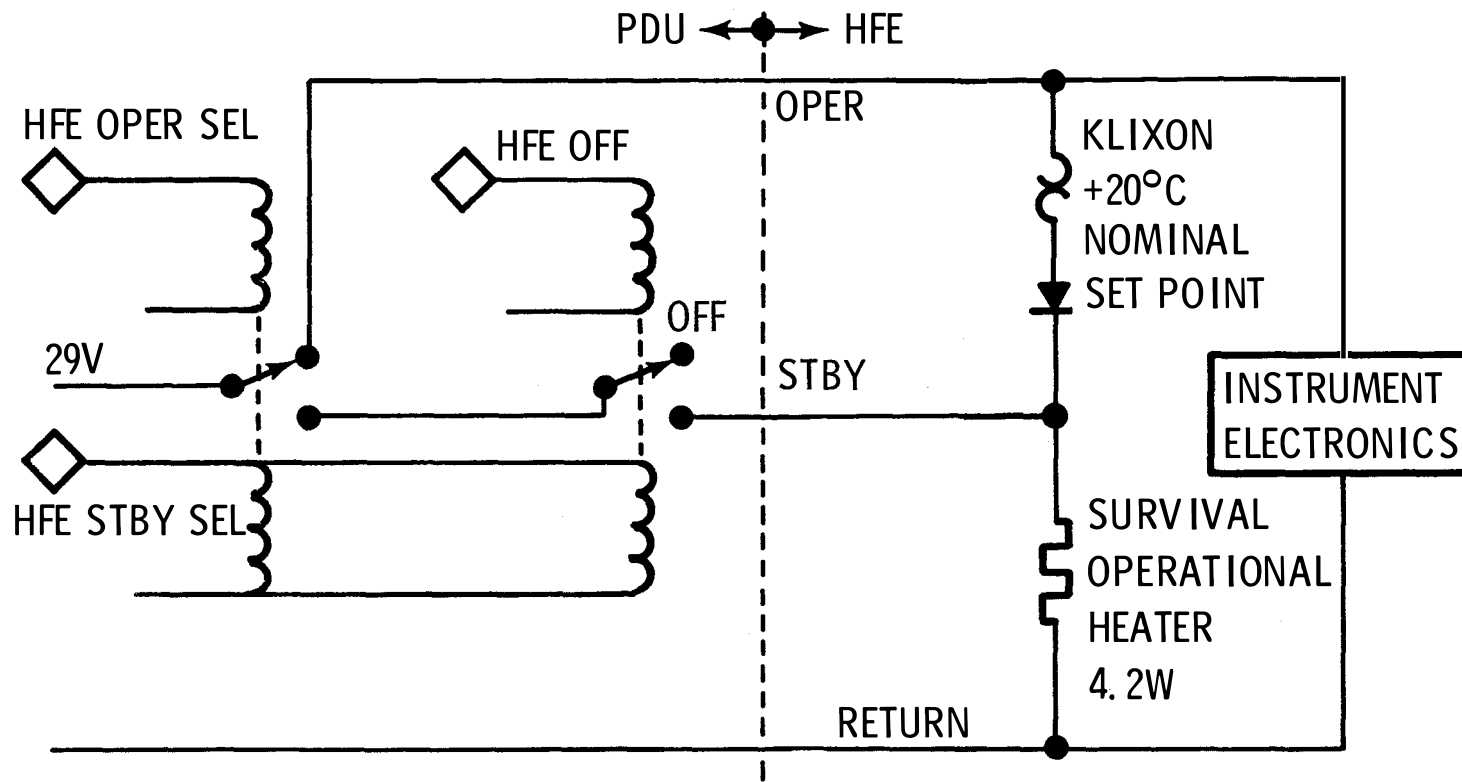

NOTE: ADDITIONAL THERMOSTAT TURNS A PORTION OF INSTRUMENT ELECTRONICS ON/OFF BETWEEN MEASUREMENTS IF TEMP IS LOW/HIGH

HFE POWER PROFILE

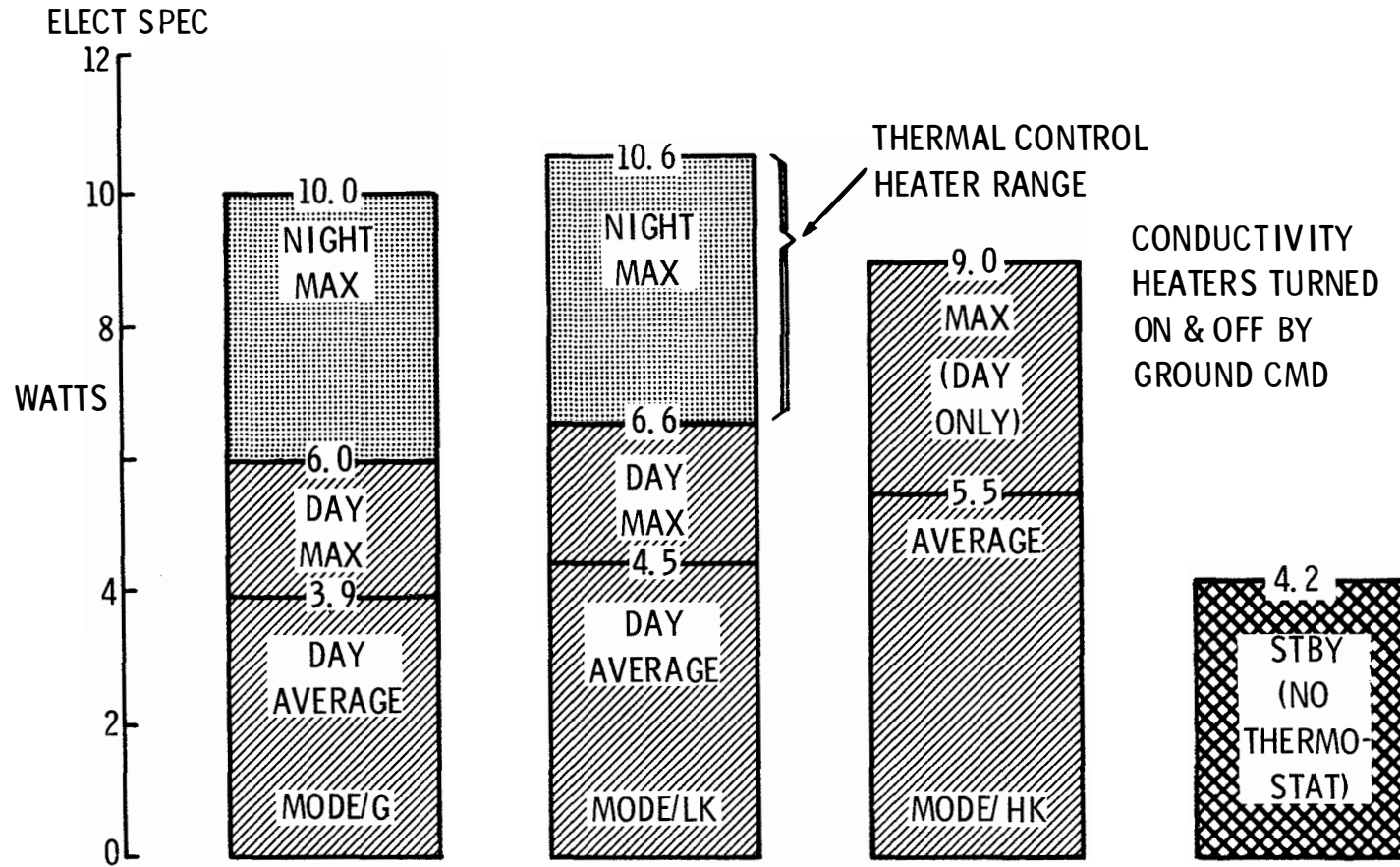

HFE TIE-DOWN

HFE PROBE
CARRYING PACKAGE

PSE

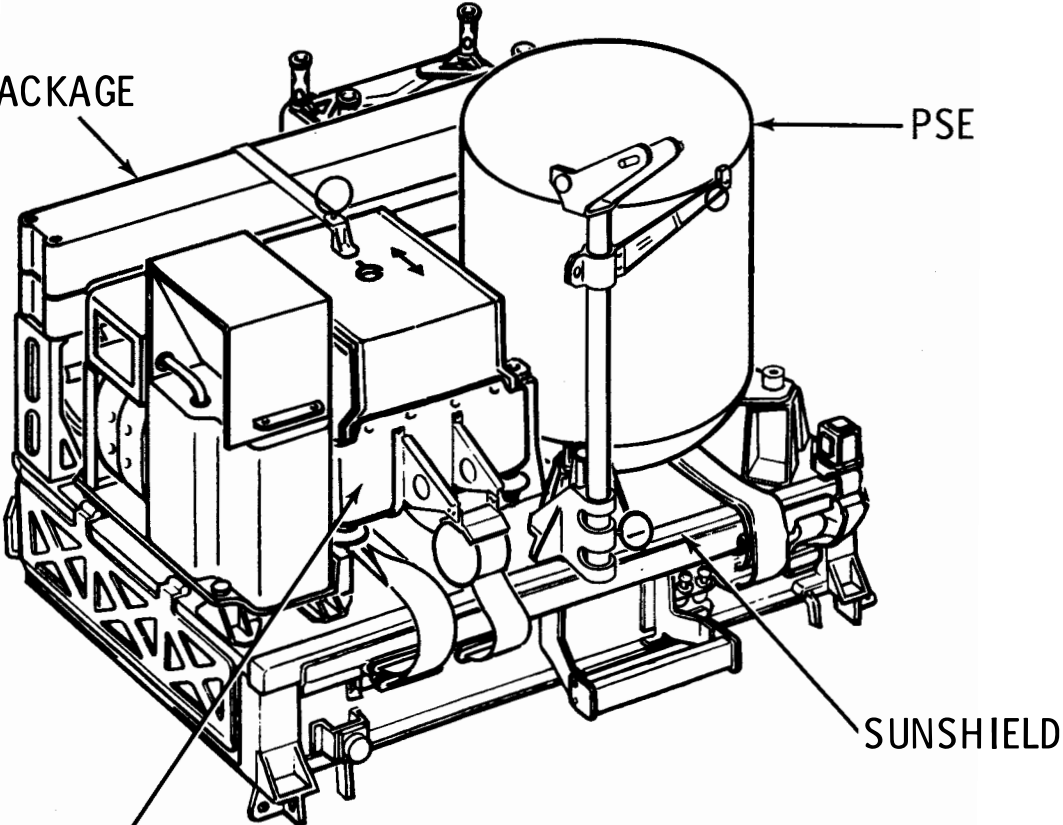

HFE ELECTRONICS

SUNSHIELD

HFE EMPLACEMENT CRITERIA

	PARAMETER	REQUIREMENT	PRIORITY	INDICATOR	COMMENTS
ELECTRONICS PACKAGE	DISTANCE FROM SUBPACKAGE 1	29 ± 1 ft (30 ft CABLE)	2	PACED OFF	TO OBTAIN PROBE SEPARATION FROM RTG*
	DIRECTION FROM SUBPACKAGE 1	AWAY FROM RTG	2	EYEBALL	GREATER THAN 80° FROM RTG
	LEVEL	$\pm 12^\circ$ OF VERTICAL	2	EYEBALL	INTERACTS WITH ALIGNMENT
	ALIGN WRT SHADOW	$\pm 5^\circ$ OF E-W	2	ARROW** AND SHADOWS	THERMAL REQ FOR SUN SHIELD SHADOWS TO ALIGN WITH PLATE EDGES
PROBES (2)	DISTANCE FROM ELECTRONICS	17 ± 1 ft (20 ft CABLE TO HOLE)	1	PACED OFF (CABLE MARKED FOR DEPTH)	TO OBTAIN 30 ft SEPARATION BETWEEN PROBES (REQUIREMENT)
	DIRECTION FROM ELECTRONICS	AT LEAST 140° APART	1	PAINT LINES***	PROBE AND RTG SEPARATION* AVOID SHADOWS FROM ALL SUBSYSTEMS
	VERTICAL ALIGNMENT	WITHIN $\pm 15^\circ$	2	EYEBALL	OBJECTIVE FOR DRILLING
EXPERIMENT INTERRELATION	* SEPARATION DISTANCE FROM RTG: 40 ft MINIMUM, AVOID MAJOR DISTURBANCES (TRAMPLING, ETC.) AND SHADOWS IN 17 ft CIRCLE AROUND PROBE.				
SPECIAL REQUIREMENTS	** ARROW NOMINALLY POINTS EAST-WEST *** PAINT LINES GIVE 120° DIRECTIONS CENTERED ON N-S AXIS BUT ALLOW ESTIMATION OF OTHER DIRECTIONS.				

APR 69 5178.13.23

HFE ALIGNMENT MARKINGS

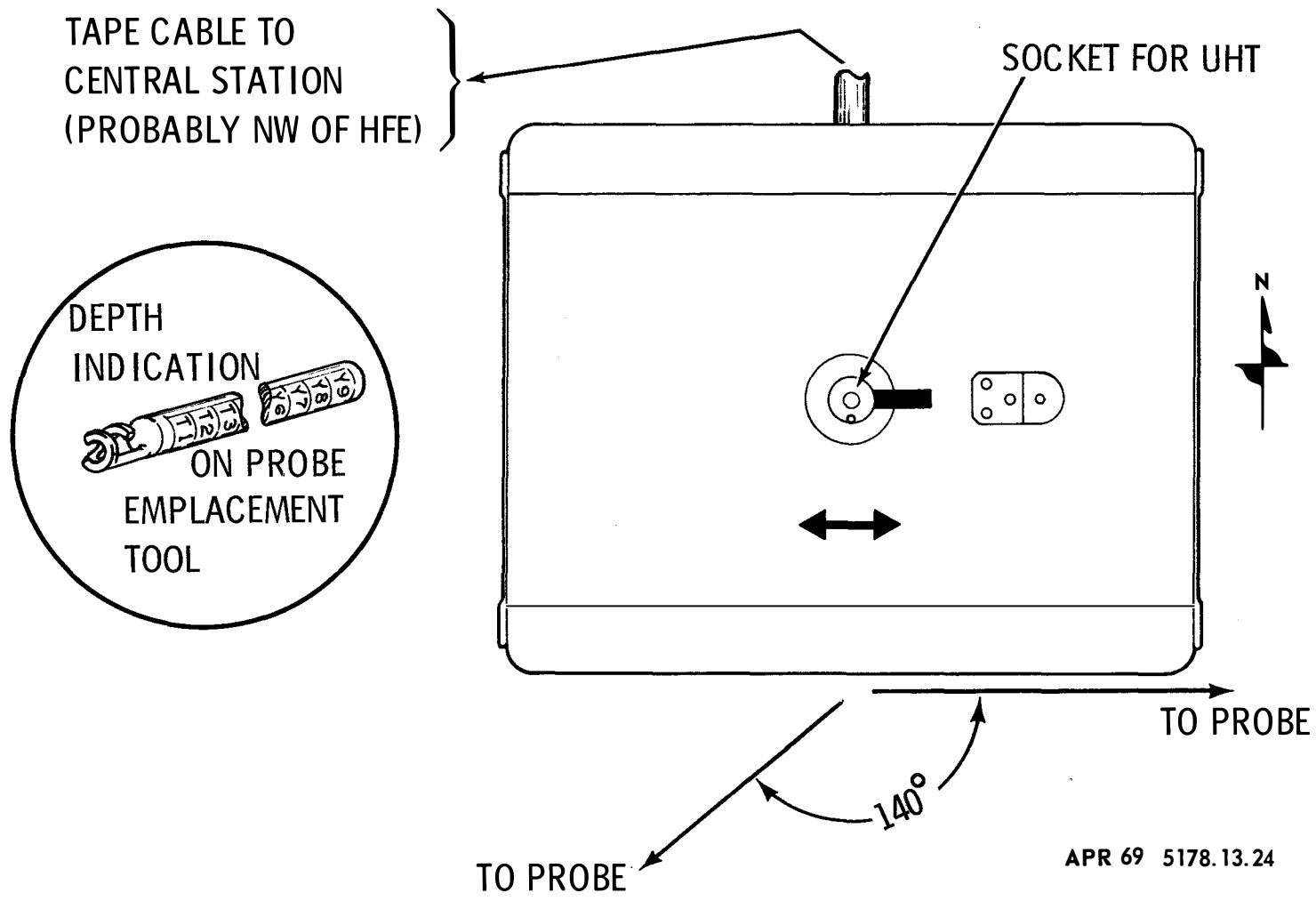

APR 69 5178.13.24

APOLLO LUNAR SURFACE DRILL

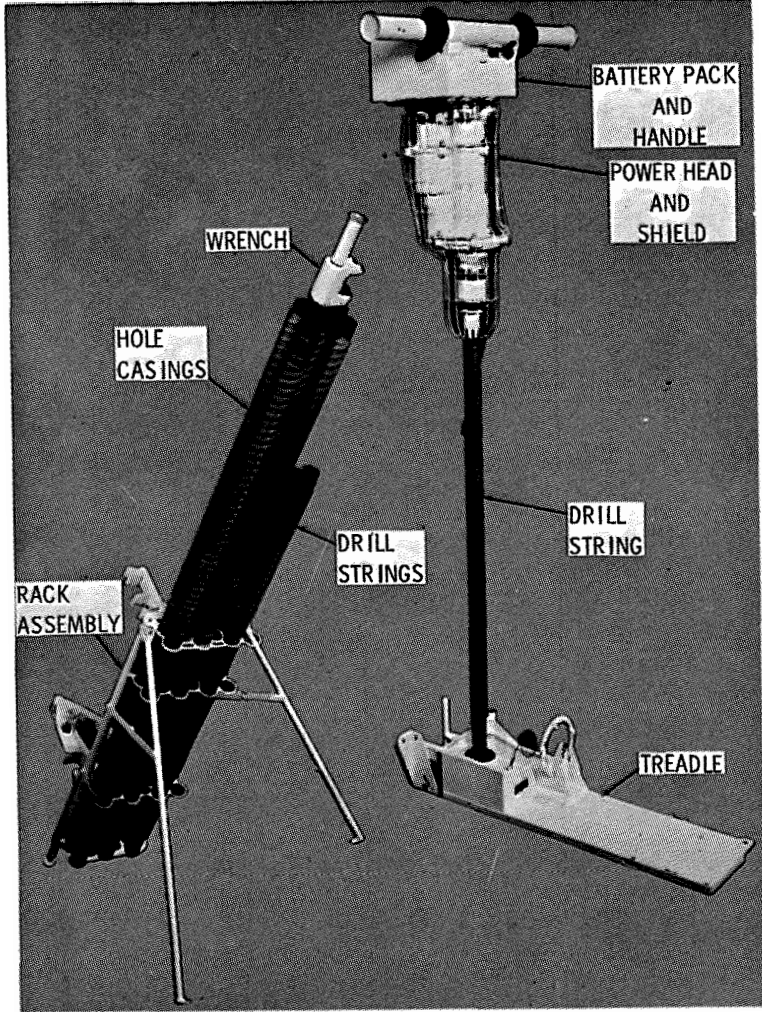

APOLLO LUNAR SURFACE DRILL

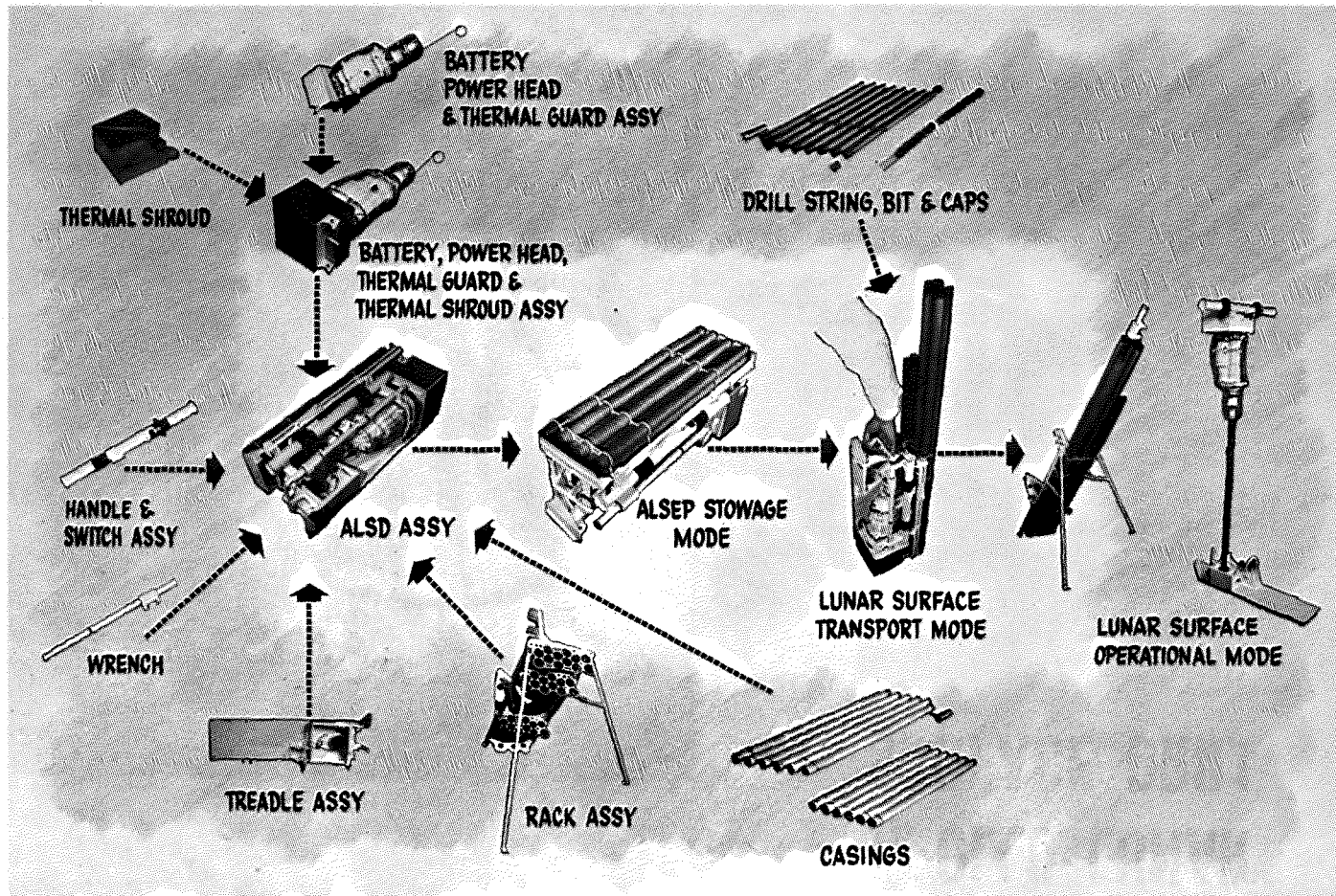

CHARGED-PARTICLE LUNAR ENVIRONMENT EXPERIMENT SUBSYSTEM

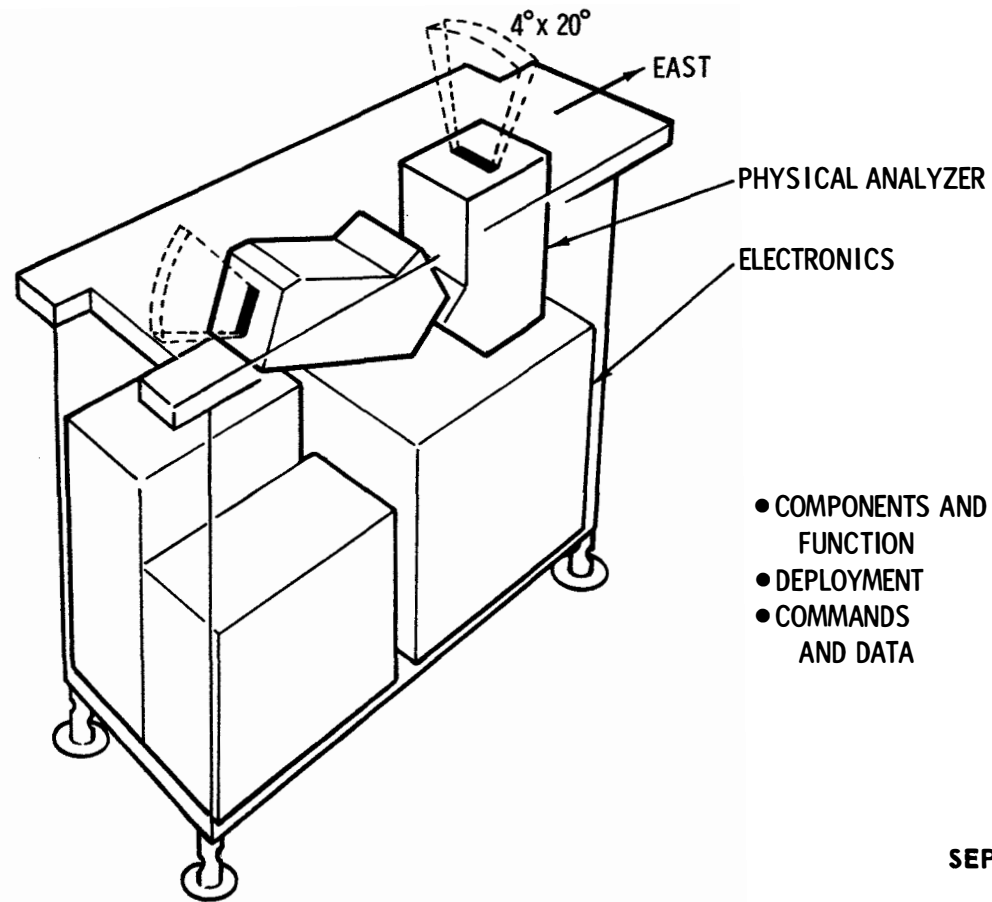

SEPT 68 5178.14.1

CPLER PHYSICAL ANALYZER

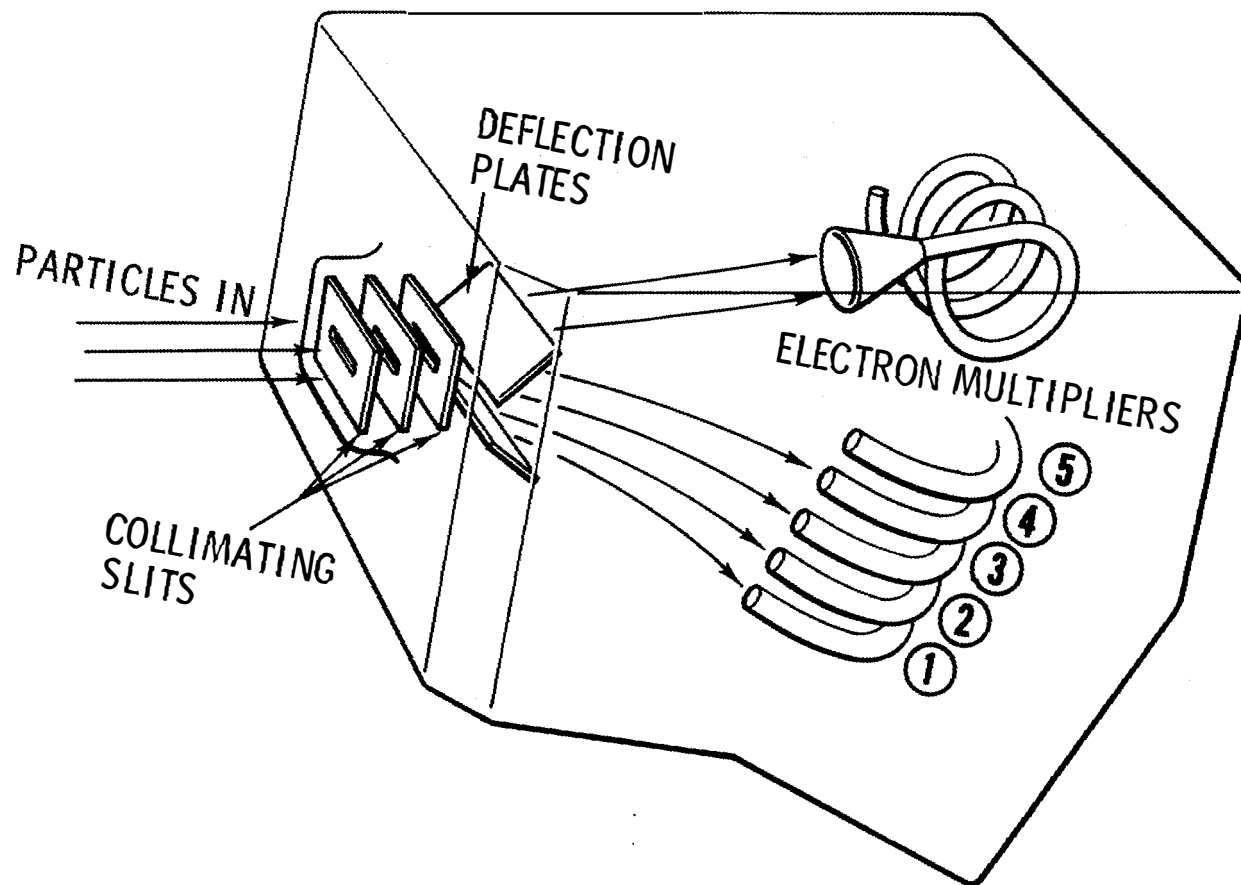

NOV 67 5178.14.2

CHANNELTRON[®] ELECTRON MULTIPLIERS

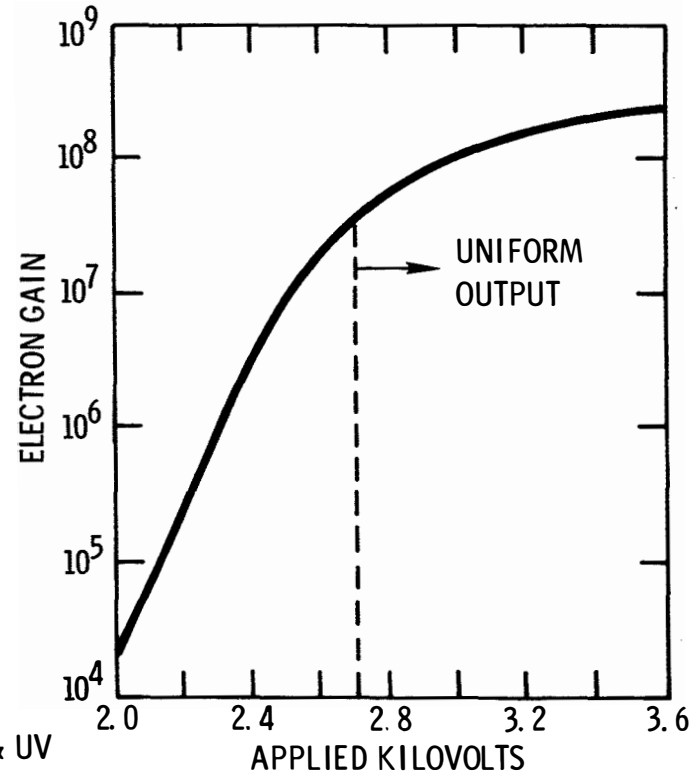
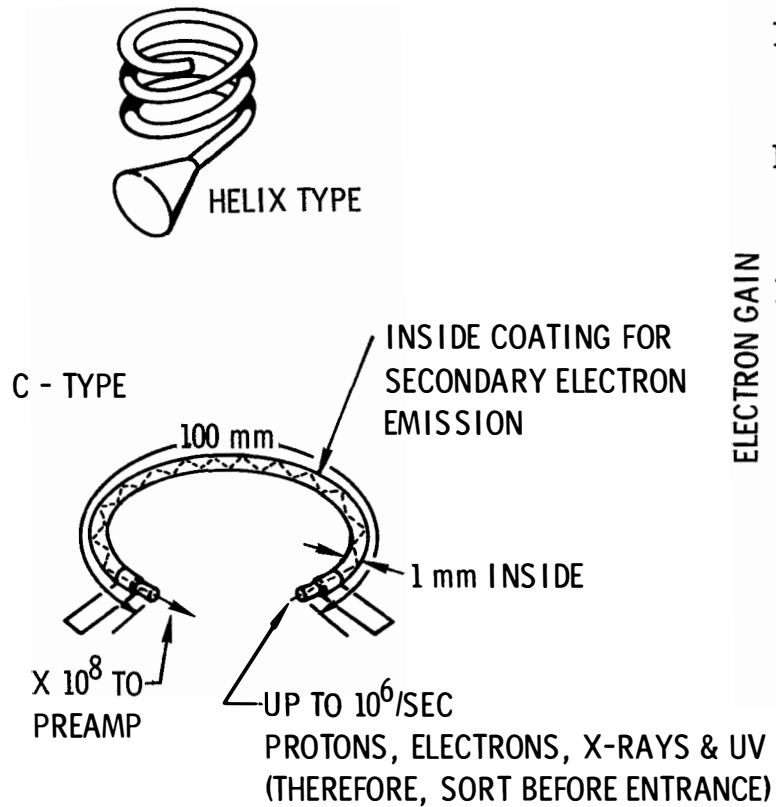

CPLEE FUNCTIONAL DIAGRAM

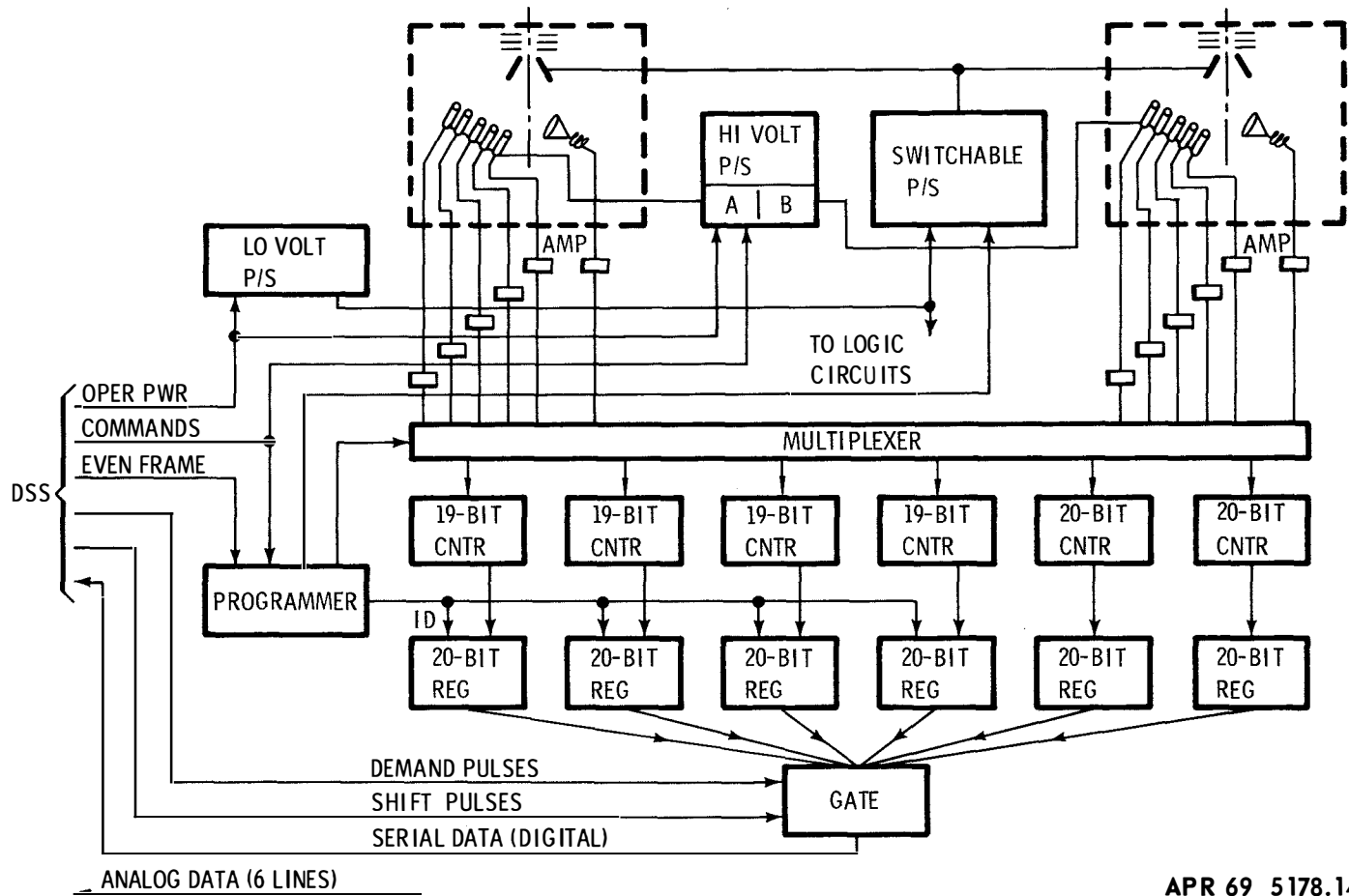

CPLLE THERMAL CONTROL

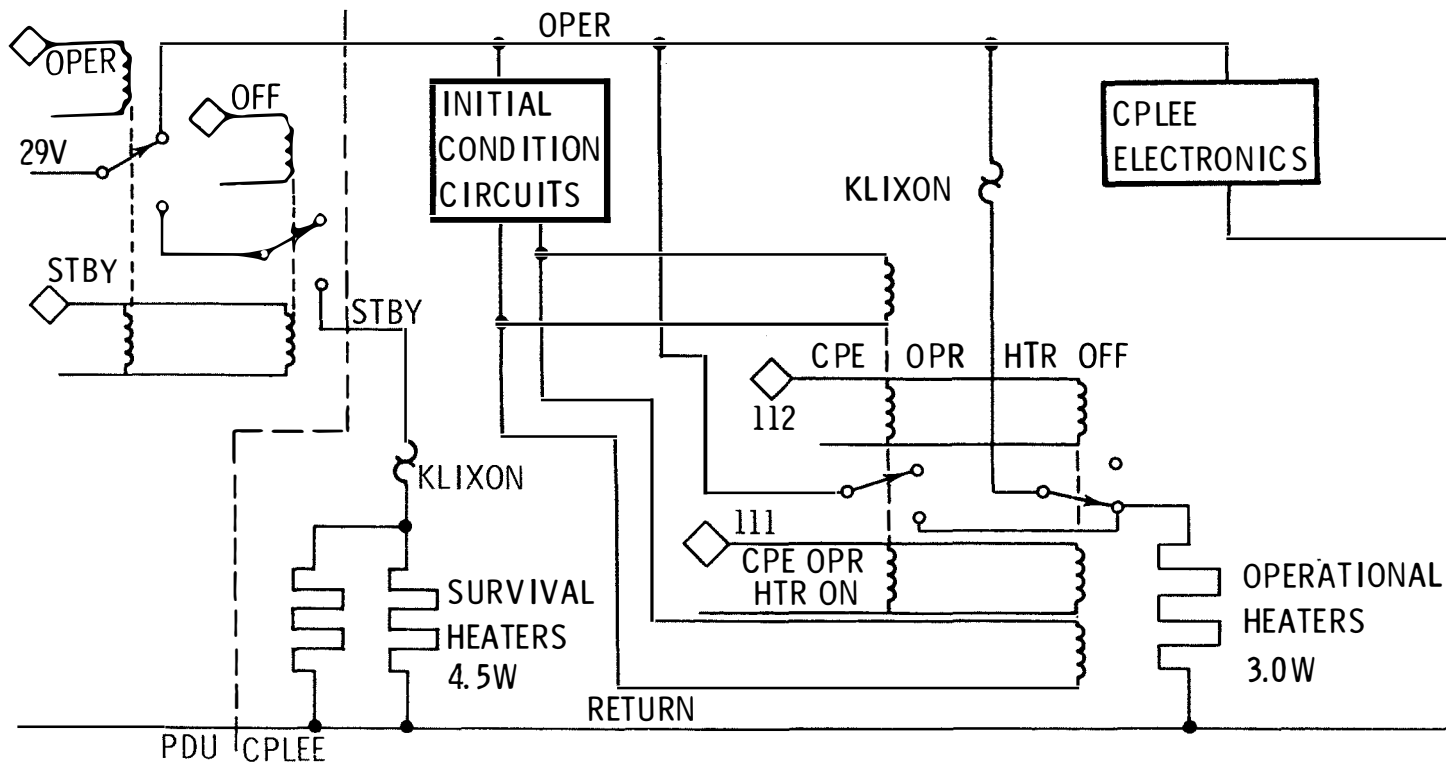

APR 69 5178.14.5

CPLLEE TIMING SEQUENCE

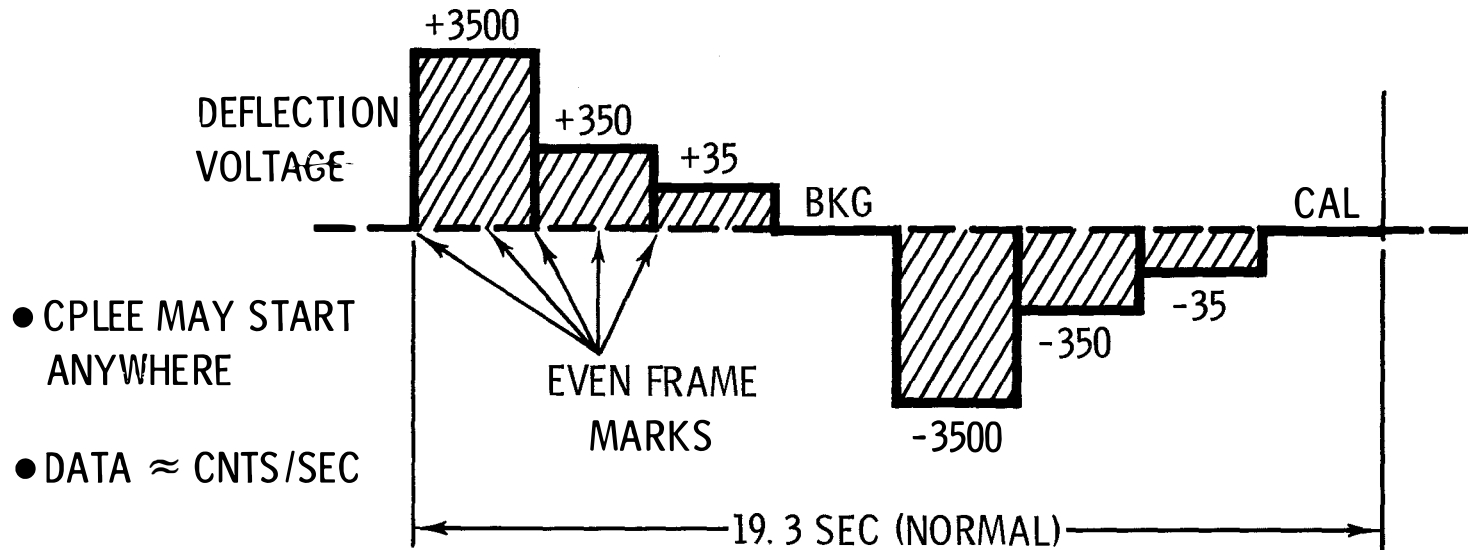
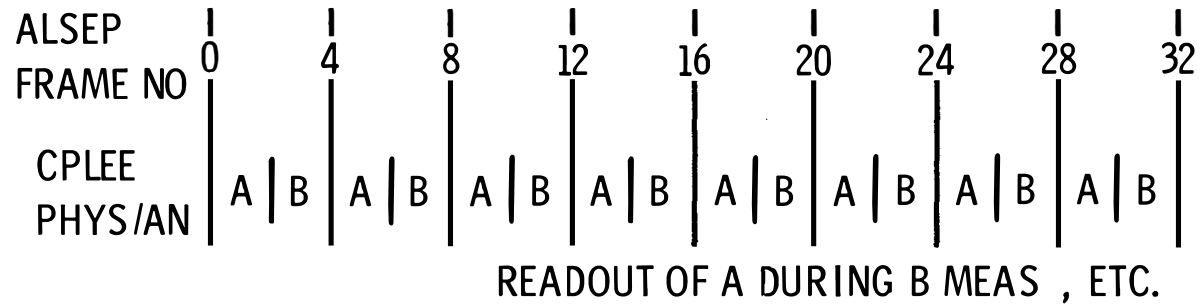

CPLEE POWER PROFILE

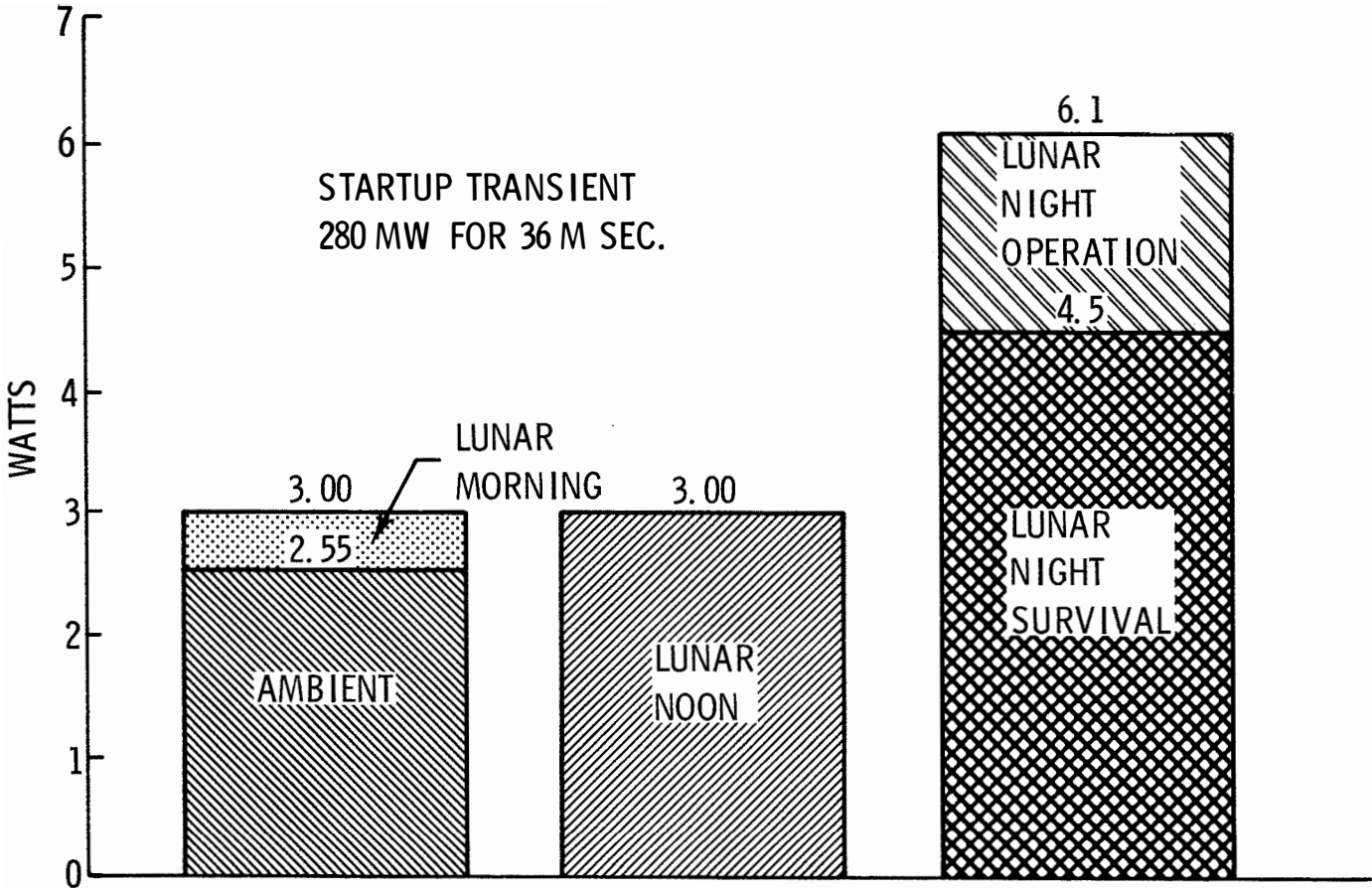

CPLEE ENERGY RANGES

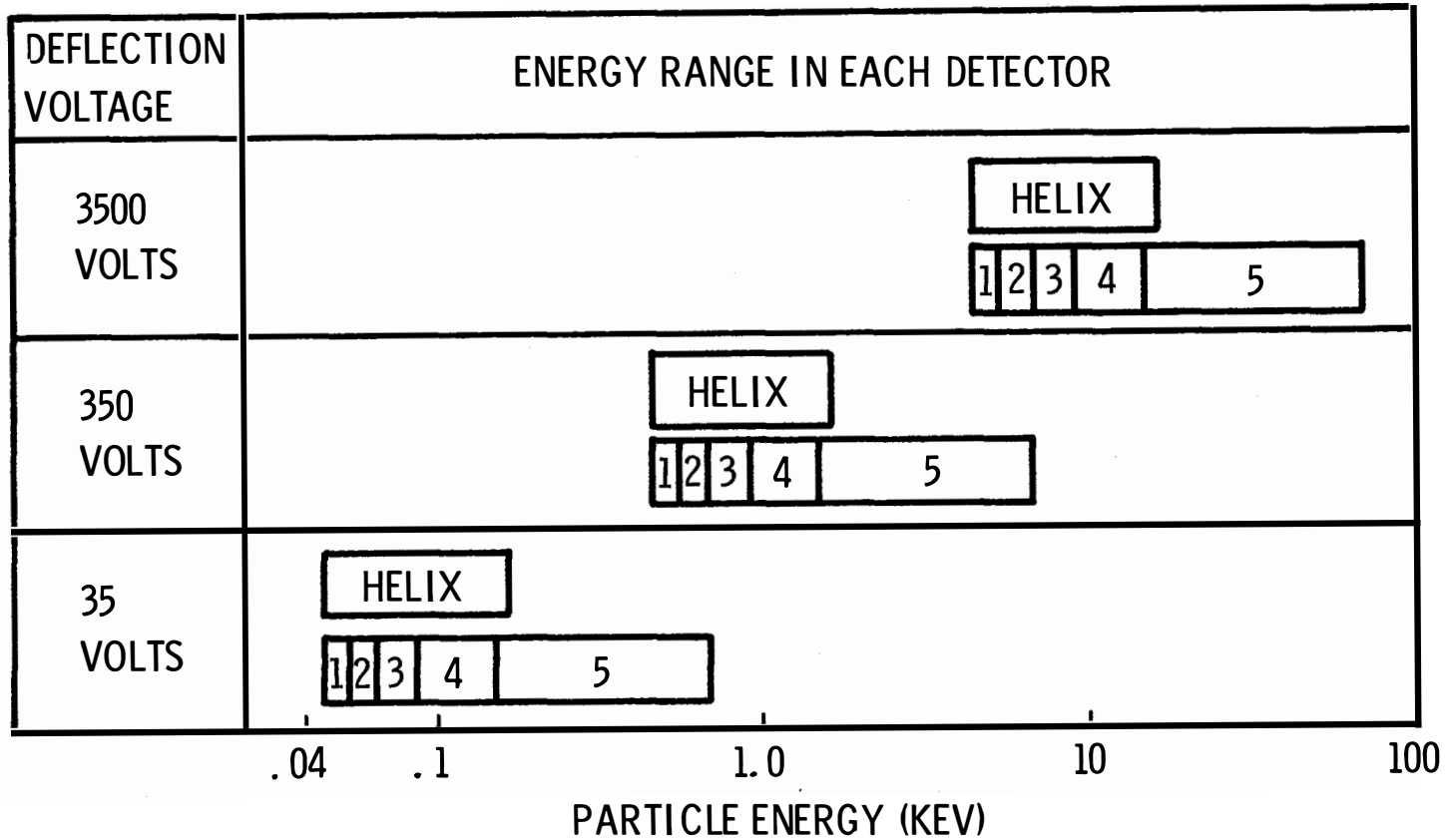

CPLEE PERFORMANCE CHECKS

TECHNIQUE	CNT/SEC
BETA SOURCE IN DUST COVER FOR COMPLETE TEST DURING INITIAL OPERATION	0 TO 2000 (DEPENDING ON CHANNEL)
TEST OSCILLATOR INPUT TO ALL PREAMPS ONCE DURING EACH OPERATING CYCLE	$\approx 350,000$ Hz (FILLS 19TH BIT OF REGISTER)

GUILLOTINE
RELEASE

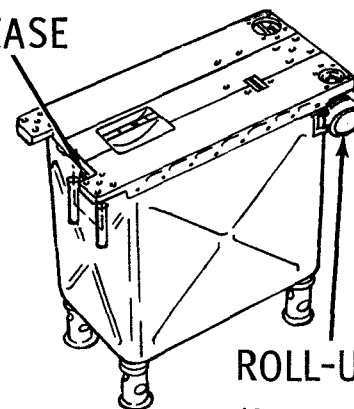

ROLL-UP COVER
(2 METAL STRIPS
IN PLASTIC)

APR 69 5178.14.9

CPLEE TIE-DOWN

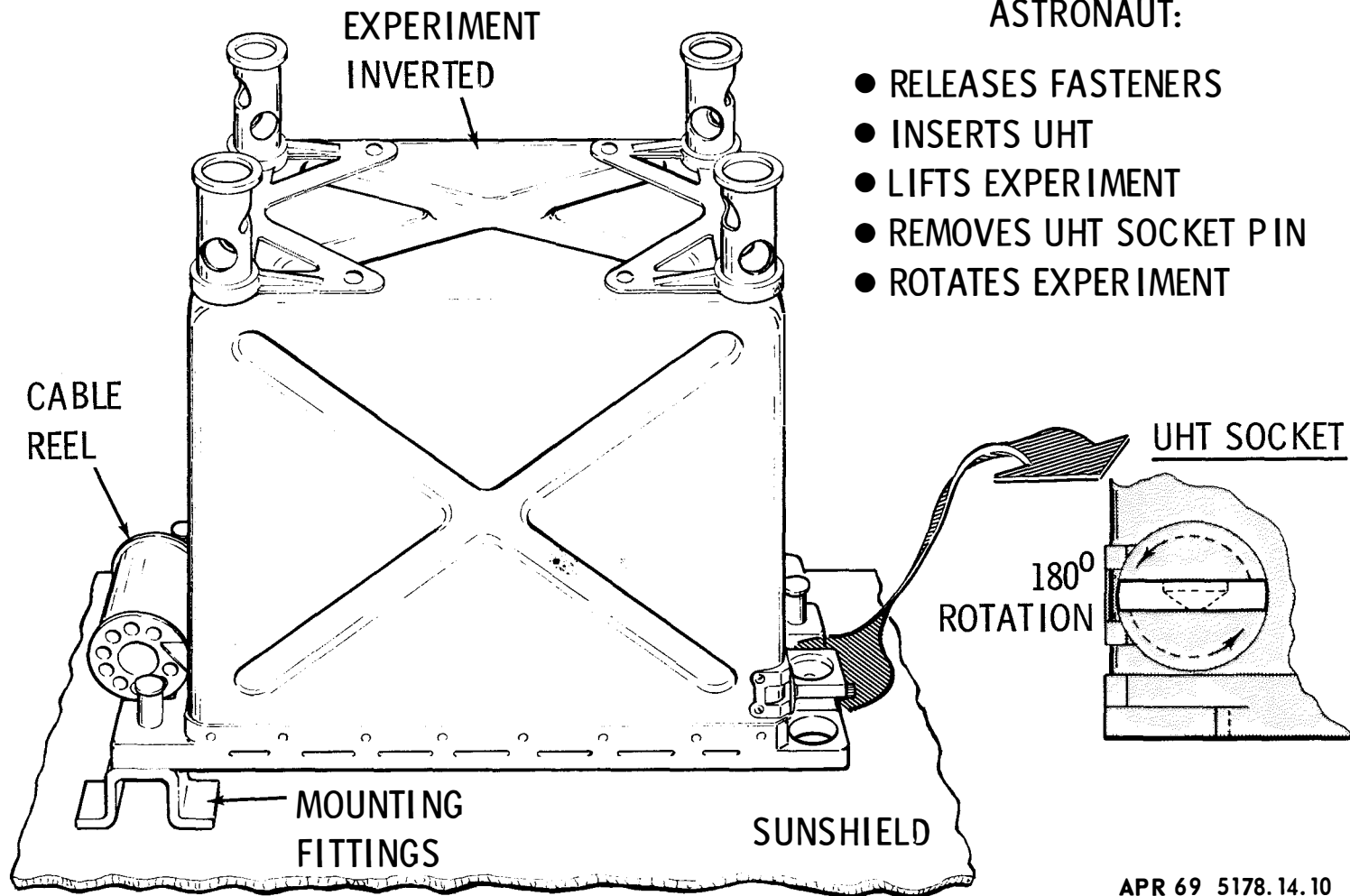

ASTRONAUT:

- RELEASES FASTENERS
- INSERTS UHT
- LIFTS EXPERIMENT
- REMOVES UHT SOCKET PIN
- ROTATES EXPERIMENT

APR 69 5178.14.10

CPLEE EMPLACEMENT CRITERIA

PARAMETER	REQUIREMENT	PRIORITY	INDICATOR	COMMENTS
DISTANCE FROM SUBPACKAGE 1	10 ± 1 FT (11 FT CABLE)	1	PACED OFF	CRITICAL SEPARATION IS FROM RTG AND SUBPACKAGE 1
DIRECTION FROM SUBPACKAGE 1	AT LEAST 60° FROM RTG AND 30° FROM N-S LINE OF SUBPACKAGE 1	1	EYEBALL	AT LEAST 14 FT FROM RTG AND PREFERABLY 20 FT* AVOID FIELD OF VIEW OF CENTRAL STATION RADIATOR
SITE SELECTION	APPROX HORIZ	2	EYEBALL	75° (HALF-ANGLE) VERTICAL CONE MUST BE CLEAR EXCEPT FOR ALSEP ANTENNA.
LEVEL, WRT INDICATOR	±2.5° OF HORIZ	1	BUBBLE	INTERACTS WITH ALIGNMENT
ALIGN, WRT SHADOW	± 2° OF E-W	2	ARROW**	THERMAL REQUIREMENT
READOUT OF ALIGNMENT	± 1° OF E-W	1	TOOL & ROSE	SCIENTIFIC REQUIREMENT**
EXPERIMENT INTERRELATION	*CONTAMINATING RADIOACTIVE FIELD AT CPLEE CAUSED BY OTHER SUBSYSTEMS MUST BE LESS THAN 0.1 COUNT/SEC IN ALL CHANNELS.			
SPECIAL REQUIREMENTS	**EXPERIMENT IS BIDIRECTIONAL FOR SCIENTIFIC OUTPUT BUT ARROW POINTS E AND PARTIAL COMPASS ROSE (USING SHADOW OF HANDLING TOOL) COVERS ONLY THE RANGE FOR SUN IN EAST.			

SEPT 68 5178.14.11

CPLLEE ALIGNMENT MARKINGS

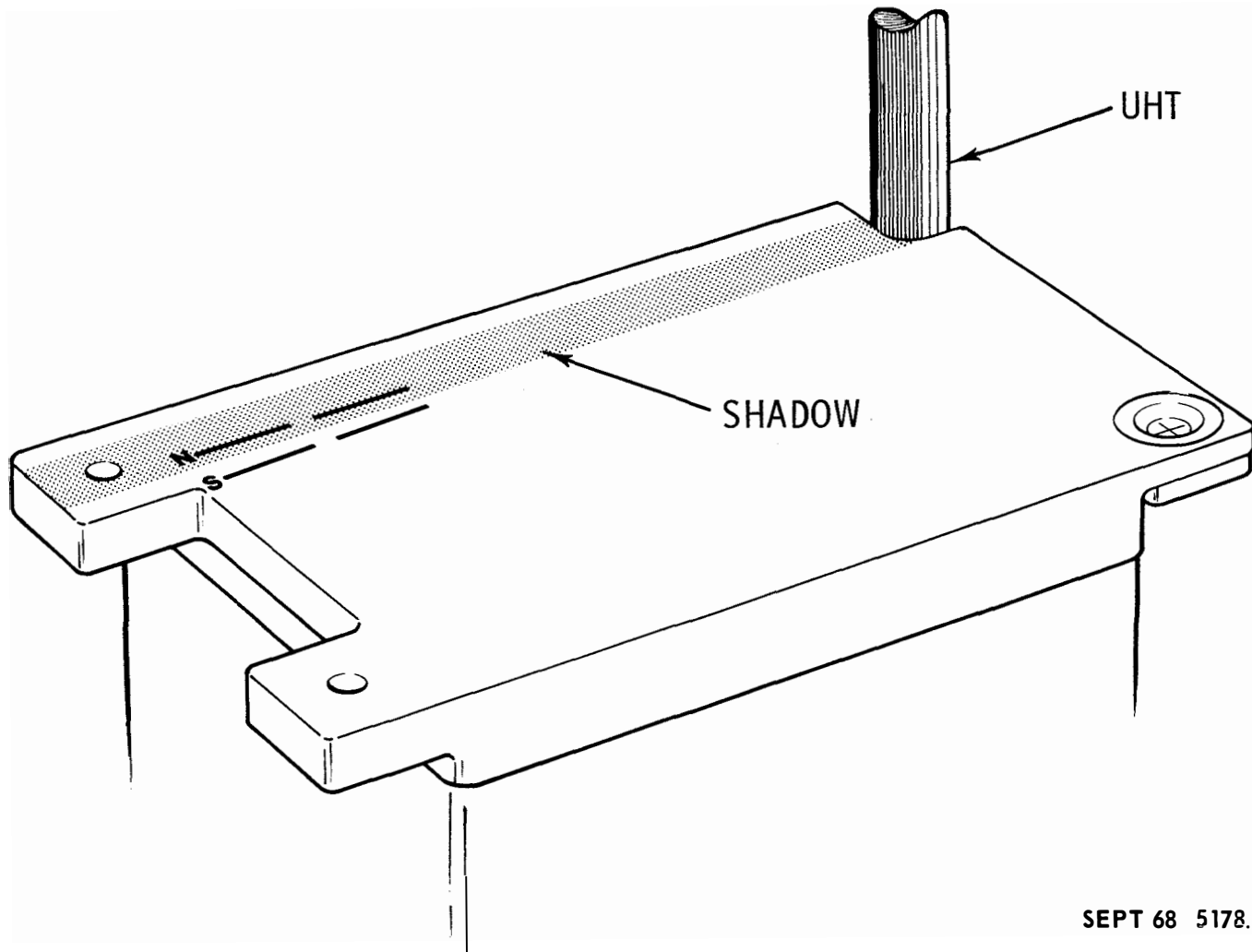

SEPT 68 5178.14.12

CPLLEE DIGITAL DATA FORMAT

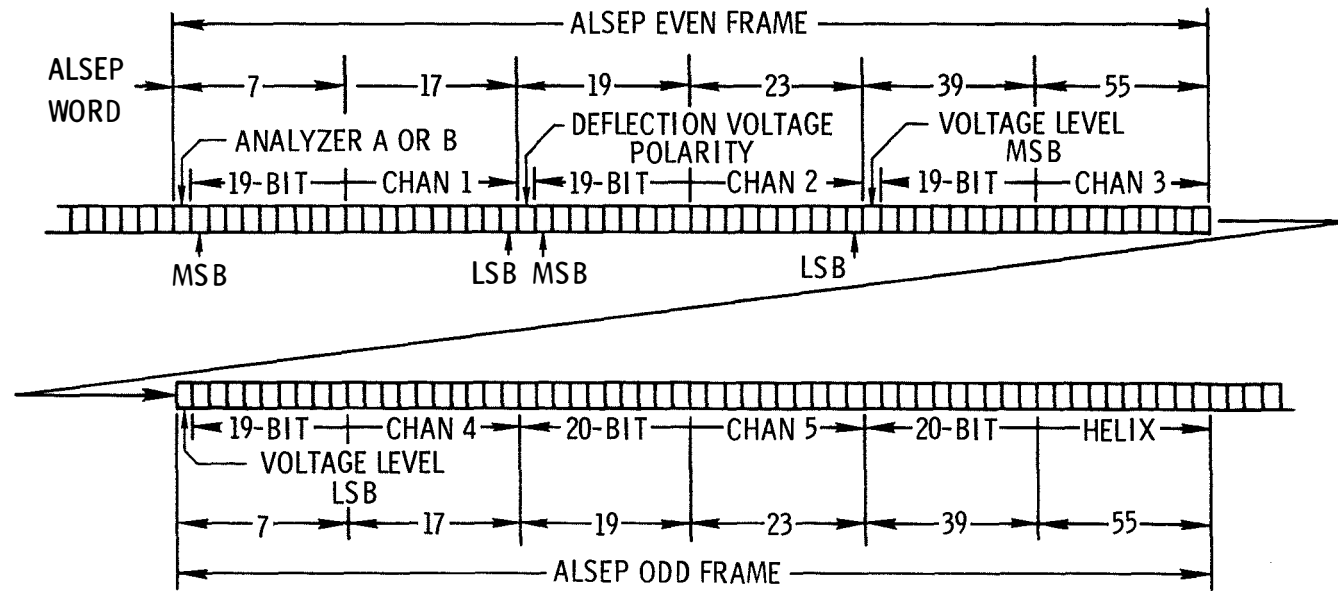

DC-01	THROUGH	DC-34	CPE DET SCI DATA
DC-85	THROUGH	DC-96	CPE CAL SIG
	DC - 97		CPE PHYS/AN ID
	DC - 98		CPE POLARITY ID
	DC - 99		CPE DEF LVL ID

CPLLE ANALOG DATA

SAMPLED ONCE PER 54-SEC
ALSEP SEQUENCE (ALSEP WORD 33)

AC - 01	CPE	DEF P/S VOLTS
AC - 02	CPE	CHAN/1 VOLTS
AC - 03	CPE	CHAN/2 VOLTS
AC - 04	CPE	CONV VOLTS
AC - 05	CPE	PHYS/AN DEG C
AC - 06	CPE	DEF P/S DEG C

NOTE: AC - 05 IS TEMPERATURE OF PHYSICAL ANALYZER A

CPLLEE COMMANDS

OCTAL COMMAND NUMBERS

111 CPE OPR HTR ON

THIS COMMAND BYPASSES THE THERMOSTAT IN THE CPLLEE AND TURNS THE OPERATIONAL HEATER ON. TO RESTORE AUTOMATIC THERMAL CONTROL THE EXPERIMENT POWER MUST BE COMMANDED TO STBY AND BACK TO OPER. THIS COMMAND HAS NO CONTROL OVER SURVIVAL (STBY) HEATERS.

112 CPE OPR HTR OFF

THIS COMMAND BYPASSES THE THERMOSTAT IN THE CPLLEE AND TURNS THE OPERATIONAL HEATER OFF, AND IS ALSO USED TO TURN OFF THE OPERATIONAL HEATER AFTER IT HAS BEEN TURNED ON BY COMMAND 111. SEE COMMAND 111 FOR RESTORATION OF AUTOMATIC THERMAL CONTROL. THIS COMMAND HAS NO CONTROL OVER SURVIVAL HEATERS. (OPERATIONAL HEATER ON/OFF VIA 111 & 112 CAN BE RECYCLED INDEFINITELY.)

113 CPE CVR GO

THIS COMMAND ACTUATES THE GUILLOTINE DEVICE FOR REMOVING THE CPLLEE DUST COVER.

114 CPE DEF SEQ ON

THIS COMMAND STARTS THE AUTOMATIC SEQUENCE OF VOLTAGES TO THE CPLLEE DEFLECTION PLATES WHENEVER IT HAS BEEN STOPPED (BY COMMAND 117). INITIAL TURN-ON OF THE EXPERIMENT IS IN THE AUTOMATIC SEQUENCE MODE.

115 CPE DEF STEP

THIS COMMAND ADVANCES THE VOLTAGE ON THE CPLLEE DEFLECTION PLATES ONE STEP EACH TIME IT IS USED, IN THE STANDARD SEQUENCE, WHEN THE SEQUENCE HAS BEEN STOPPED. IF AUTOMATIC SEQUENCE IS ON, THIS COMMAND HAS NO EFFECT.

117 CPE DEF SEQ OFF

THIS COMMAND INTERRUPTS THE AUTOMATIC SEQUENCE OF VOLTAGES TO THE CPLLEE DEFLECTION PLATES. THE VOLTAGE THEN REMAINS CONSTANT UNTIL ADVANCED BY COMMAND 115. IT IS RESTORED TO AUTOMATIC SEQUENCE BY COMMAND 114 OR BY CYCLING CPLLEE TO STBY AND BACK TO OPER.

120 CPE CHAN/HI SEL

THIS COMMAND INCREASES THE VOLTAGE ACROSS THE CHANNELTRON[®] ELECTRON MULTIPLIERS IN BOTH PHYSICAL ANALYZERS (A & B) TO THE HIGHER VALUE, ≈ 3200 VOLTS, IF IT IS AT THE LOWER SETTING, ≈ 2800 VOLTS ($\Delta = 400$ VOLTS). IF THIS COMMAND IS SENT TWICE, WITHOUT COMMAND 121 BETWEEN, THE SECOND COMMAND HAS NO EFFECT.

121 CPE CHAN/LO SEL

THIS COMMAND DECREASES THE VOLTAGE ACROSS THE CHANNELTRON[®] ELECTRON MULTIPLIERS IN BOTH PHYSICAL ANALYZERS (A & B) TO THE LOWER VALUE, ≈ 2800 VOLTS, IF IT IS AT THE HIGHER SETTING, ≈ 3200 VOLTS ($\Delta = 400$ VOLTS). IF THIS COMMAND IS SENT TWICE, WITHOUT COMMAND 120 BETWEEN, THE SECOND COMMAND HAS NO EFFECT.

COLD CATHODE GAUGE EXPERIMENT (CCGE)

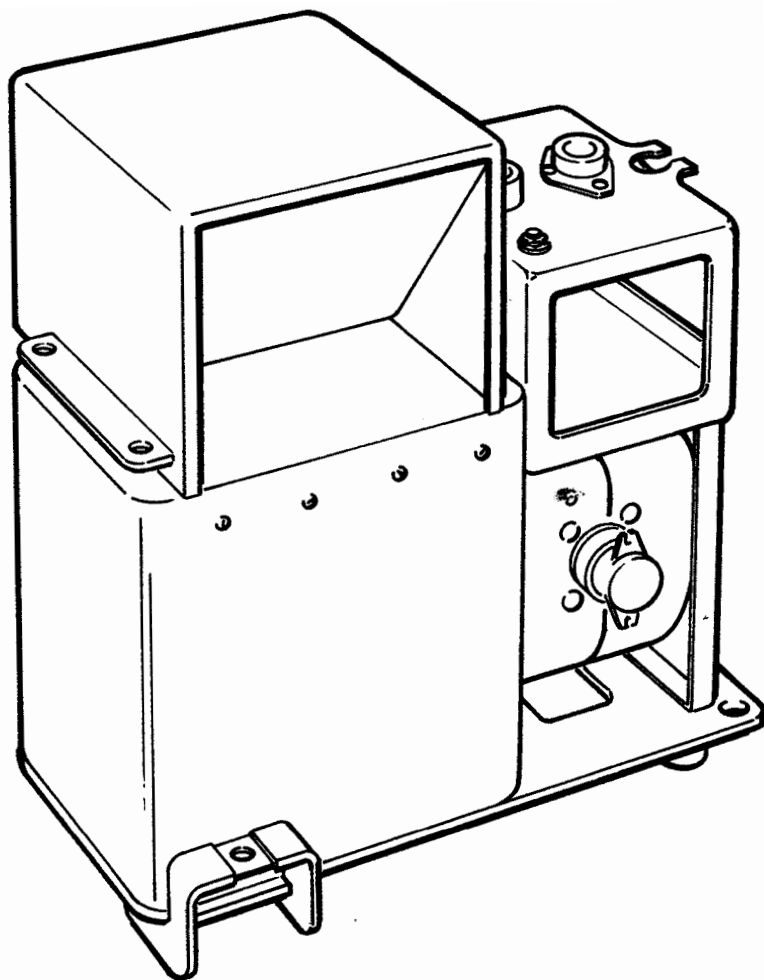

HEIGHT, IN. = 13.4
WIDTH, IN. = 4.6
DEPTH, IN. = 12.0
EARTH WEIGHT, LB = 12.5

JAN 69 5178.15.1

CCGE GENERAL FEATURES

PURPOSE IS TO DETERMINE

- DENSITY OF LUNAR ATMOSPHERE, WHERE TIME-DEPENDENT CHANGES MAY BE
 - RANDOM
 - FUNCTION OF LUNAR CYCLE
 - FUNCTION OF SOLAR ACTIVITY
- LOSS RATE OF CONTAMINANTS LEFT BY ASTRONAUTS & LM

MEASUREMENT TECHNIQUE

- GAUGE PRODUCES AN ELECTRICAL CURRENT PROPORTIONAL TO THE NEUTRAL PARTICLE DENSITY AT ITS POSITION
- CURRENT IS AMPLIFIED & CONVERTED INTO A 10-BIT WORD FOR TRANSMISSION IN THE ALSEP FORMAT

COMBINED WITH MEASURED TEMP OF GAUGE, ALLOWS CALCULATION OF LUNAR ATMOSPHERE PRESSURE

CCGE PERFORMANCE

- RANGE: 10^{-6} TO 10^{-12} TORR
- ACCURACY: $\pm 30\%$ ABOVE 10^{-10} TORR, $\pm 50\%$ BELOW 10^{-10} TORR
- OPERATING VOLTAGE: + 4500V
- MAGNETIC FIELD: 1020 GAUSS
- GAUGE BODY CONSTRUCTED OF 304 STAINLESS STEEL
- SEVEN OVERLAPPING MEASUREMENT RANGES (SWITCHED BY CMD OR BY INTERNAL LOGIC) HANDLE CURRENTS BETWEEN 10^{-6} AMPS (RANGE 1) AND 10^{-12} AMPS (RANGE 7)

CCGE BLOCK DIAGRAM

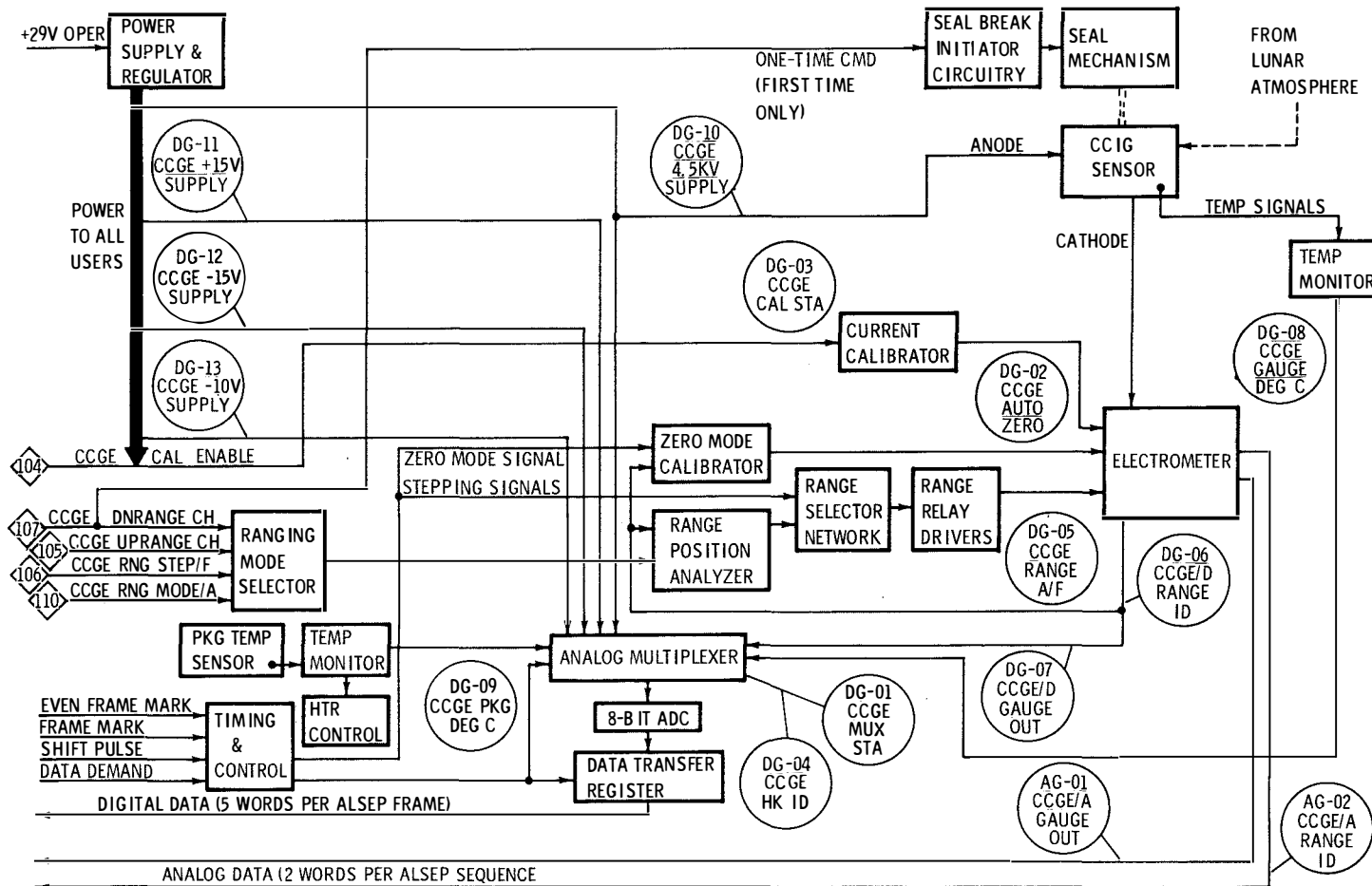

JAN 69 5178.15.4

CCGE SEAL BREAK

- INITIATED BY FIRST TRANSMISSION OF CMD 107
(MAY BE NECESSARY TO TRANSMIT CMD 105 PRIOR
TO 107 FOR ACTUATION OF SEAL BREAK)
- EXPLOSIVE-ACTUATED PISTON RELEASES SPRING
WHICH RETAINED ORIFICE COVER
- RELEASE OF SPRING CAUSES COVER TO FLIP OFF

CCGE RANGE CHANGE

- 7 OVERLAPPING RANGES FROM 10^{-12} TO 10^{-6} AMPS
- SELECTED EITHER AUTOMATICALLY OR BY COMMAND
- AUTOMATIC
 - UP-DOWN COMPARATOR OF RANGE POSITION ANALYZER SENSES ELECTROMETER OUTPUT VOLTAGE
 - WHEN VOLTAGE PASSES UPPER OR LOWER TRIP POINT VALVES, COMPARATOR SUPPLIES UP-RANGE OR DOWN-RANGE SIGNAL TO RANGE SELECTOR NETWORK
 - RANGE SELECTOR NETWORK (COUNTING REGISTER) TRACKS THE RANGES, SUPPLIES SIGNALS TO ACTUATE THE RANGE RELAY DRIVERS, & SUPPLIES ANALOG & DIGITAL TM OF RANGE ID
- BY COMMAND
 - TRANSMIT CMD 104 OR 107 TO SELECT UP-RANGE OR DOWN-RANGE DIRECTION FOR FORCED RANGE CHANGE
 - TRANSMIT CMD 106 TO EXECUTE FORCED RANGE STEP IN THE PRESET DIRECTION. THIS OVERRIDES RANGE POSITION ANALYZER & SUPPLIES SIGNAL TO RANGE SELECTOR NETWORK.
 - NEW RANGE WILL BE RETAINED UNTIL:
 - STEPPED BY TRANSMISSION OF CMD 106
 - REVERSED (CMD 104 OR 107) & STEPPED (CMD 106)
 - RESET TO AUTOMATIC MODE (CMD 110)

CCGE SELF CALIBRATION

- PROVIDES CHECK OF ELECTROMETER CURRENT-TO-VOLTAGE CONVERSION & CORRECTS (COMPENSATES) FOR ELECTROMETER ZERO DRIFT
- CURRENT CALIBRATION
 - TRANSMISSION OF CMD 104 ENABLES CURRENT CALIBRATOR
 - CALIBRATION OCCURS AT NEXT CYCLE OF ZERO COMPENSATION
 - GAUGE OUTPUT TO ELECTROMETER IS REPLACED BY PRECISION CURRENT SOURCE
 - ELECTROMETER STEPS THROUGH 7 RANGES
 - AFTER 7 CALIBRATION STEPS, CURRENT SOURCE IS REPLACED BY GAUGE OUTPUT (NORMAL OPERATION)
- ZERO MODE CALIBRATOR
 - ACTUATED BY INTERNAL TIMING EVERY 30.9 MIN
 - GAUGE OUTPUT TO ELECTROMETER IS DISCONNECTED & OFFSET COMPENSATION NETWORK ADJUSTED (AUTOMATICALLY) TO CORRECT FOR SIGNAL DRIFT
 - CCGE THEN RETURNS TO NORMAL OPERATION, UNLESS CURRENT CALIBRATION HAS BEEN ENABLED (CMD 104)

CCGE THERMAL CONTROL

- STRUCTURAL HOUSING COVERED WITH THERMAL COATING
- SUNSHIELD (WITH REFLECTOR) SHADES THERMAL PLATE FROM DIRECT SUNLIGHT & ALLOWS RADIATIVE COUPLING TO DEEP SPACE
- REFLECTOR REDUCES HEAT INPUT FROM LUNAR SURFACE TO THERMAL PLATE
- ELECTRICAL HEATER PROVIDES 4.5W INPUT TO ELECTRONICS
 - INTERMITTENTLY IN OPER PWR MODE
(CONTROL "ON" BELOW $\approx 20^{\circ}\text{F}$)
- NORMAL OPERATION (LUNAR DAY/NIGHT) FOR ELECTRONICS ANTICIPATED $+85^{\circ}\text{C}$ TO -20°C

CCGE POWER PROFILE

- SEAL BREAK BY CAPACITANCE DISCHARGE

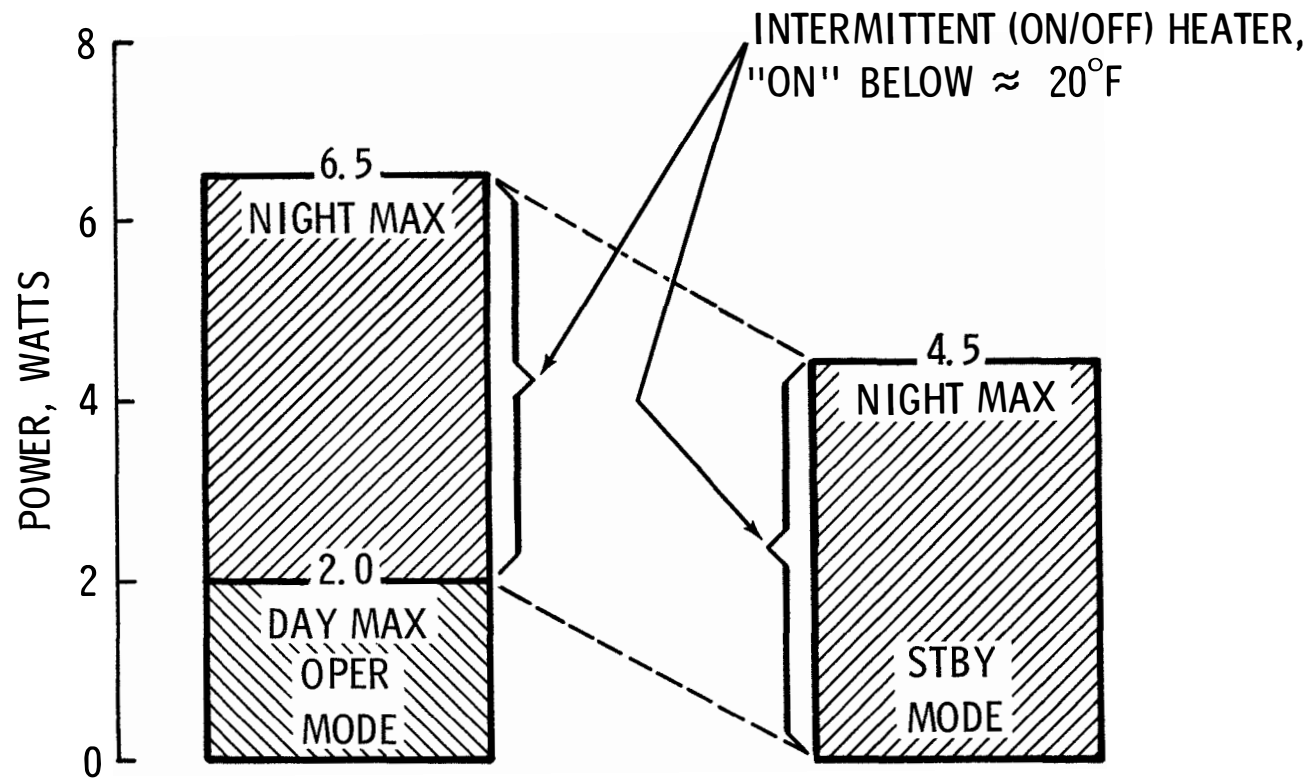

CCGE EMPLACEMENT CRITERIA

PARAMETER	REQUIREMENT	PRIORITY	INDICATOR	COMMENTS
DISTANCE FROM SUBPACKAGE 1	55 ± 5 FT (60-FT CABLE)	2	PACED OFF	INTERCHANGEABLE WITH SIDE
DIRECTION FROM SUBPACKAGE 1	S (MAY BE N)	2	EYEBALL	TO SATISFY ORIFICE REQUIREMENT
SITE SELECTION	≈ SMOOTH	2	EYEBALL	NO LEGS ON CCGE
LEVEL, WRT INDICATOR	5° OF HORIZ	1	BUBBLE	INTERACTS WITH ALIGNMENT
ALIGN, WRT SHADOW	5° OF E-W	1	ARROW & "E"	SHADOW OF UHT COVERS "E"
ALIGN ORIFICE	AWAY FROM (± 90°) LM & CENT STA	2	EYEBALL	EXACT ALIGNMENT SET BY SHADOW REQUIREMENT
SPECIAL REQUIREMENTS	PLANNED DEPLOYMENT IS SOUTH OF CENT STA BUT WOULD BE REVERSED IF LM IS SOUTH OF CENT STA			

JAN 69 5178.15.10

CCGE COMMANDS

OCTAL CMD NUMBER

104 CCGE CAL ENABLE

THIS CMD (CG-01) IS A 1-STATE CMD WHICH CAUSES THE ELECTROMETER CALIBRATION CYCLE TO OCCUR AT THE NEXT ZERO MODE CALIBRATION (EVERY 30.9 MIN). IF CMD 104 IS TRANSMITTED MORE THAN ONCE BEFORE THE TIME OF CALIBRATION ARRIVES, THE EFFECT IS THE SAME AS ONE CMD. AN ELECTROMETER CALIBRATION CYCLE CONSISTS OF STEPPING THROUGH THE 7 RANGES OF MEASUREMENT WHILE APPLYING PRECISION CURRENTS TO THE ELECTROMETER.

105 CCGE UPRANGE CH

THIS CMD (CG-02) IS A 1-STATE CMD WHICH SELECTS THE UPRANGE DIRECTION FOR FORCED RANGE CHANGES. REPEATED TRANSMISSION OF THIS CMD HAS NO EFFECT. SUBSEQUENT TRANSMISSION OF CMD 106 CAUSES THE RANGE CHANGE AND LOCKS OUT THE AUTOMATIC RANGE CHANGE. IT MAY BE NECESSARY TO TRANSMIT CMD 105, FOLLOWED BY CMD 107, TO EXECUTE THE CCGE SEAL BREAK

106 CCGE RNG STEP/F

THIS CMD (CG-03) IS A MULTI-STATE CMD WHICH FORCES THE ELECTROMETER SENSITIVITY RANGE TO CHANGE ONE STEP (IN THE DIRECTION PRE-SELECTED BY CMD 105 OR 107) EACH TIME CMD 106 IS TRANSMITTED. CMD 106 ALSO LOCKS OUT AUTOMATIC RANGE CHANGES UNTIL RELEASED BY CMD 110. REPEATED TRANSMISSION OF CMD 106 ADVANCES THE RANGE UNTIL THE MAXIMUM (OR MINIMUM) VALUE IS OBTAINED: FURTHER TRANSMISSION HAS NO EFFECT.

107 CCGE DNRANGE CH

THIS CMD (CG-04) IS A 1-STATE CMD, SIMILAR TO CMD 105, EXCEPT THAT IT SELECTS THE DOWNRANGE DIRECTION FOR FORCED RANGE CHANGES. IT ALSO BREAKS THE CCGE SEAL AT THE TIME OF FIRST TRANSMISSION UNLESS THE TOGGLE IS IN THE ADVERSE SETTING. IF SO, CMD 105 FOLLOWED BY CMD 107 WILL EXECUTE CCGE SEAL BREAK

110 CCGE RNG MODE/A

THIS CMD (CG-05) IS A 1-STATE CMD WHICH, FOLLOWING TRANSMISSION OF CMD 106, RELEASES THE RANGE CHANGE LOCKOUT AND ENABLES AUTOMATIC RANGE CHANGES, REPEATED TRANSMISSION OF THIS CMD HAS NO EFFECT. AT TURN-ON, THE CCGE INITIALIZES IN THE AUTOMATIC MODE OF (RANGE CHANGE) OPERATION.

CCGE DATA FORMAT

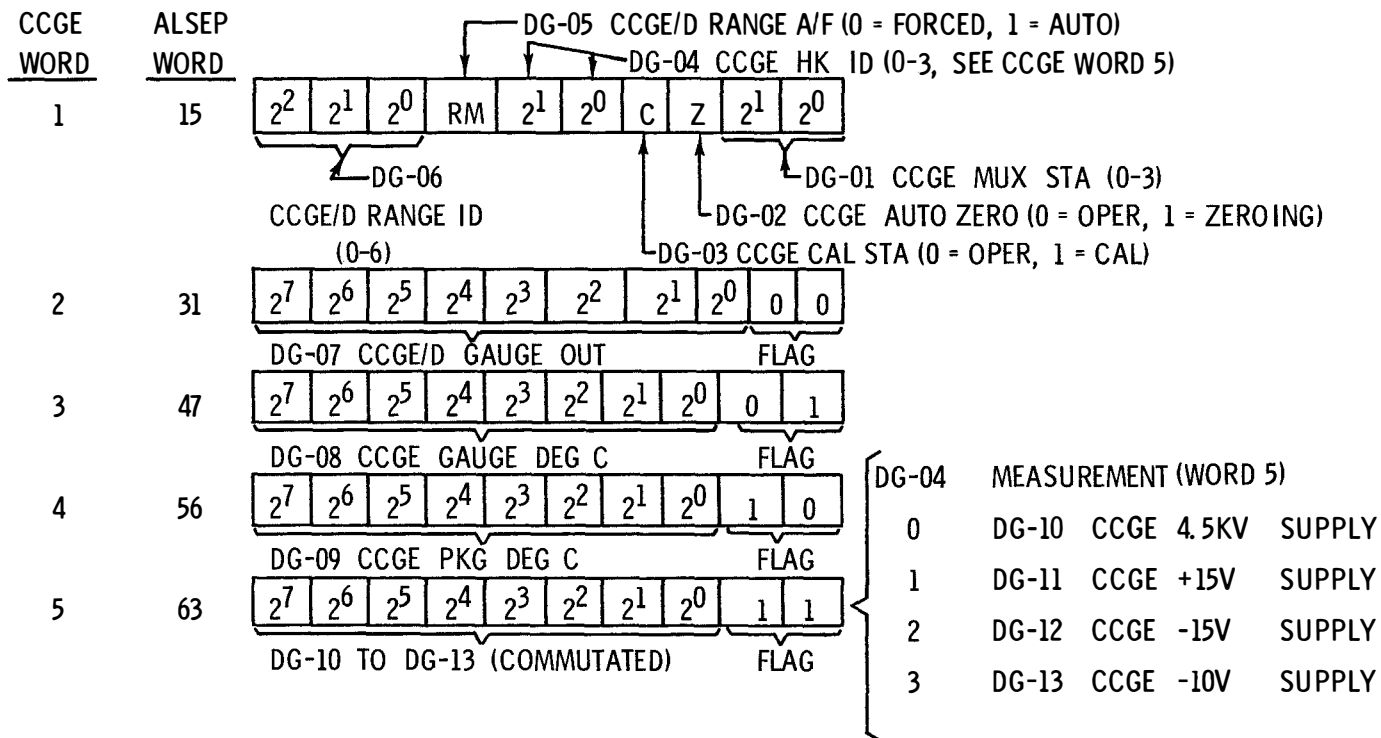

CCGE DATA SUMMARY

DG-01	CCGE MUX STA	DG-08	CCGE GAUGE DEG C
DG-02	CCGE AUTO ZERO	DG-09	CCGE PKG DEG C
DG-03	CCGE CAL STA	DG-10	CCGE 4.5KV SUPPLY
DG-04	CCGE HK ID	DG-11	CCGE +15V SUPPLY
DG-05	CCGE RANGE A/F	DG-12	CCGE -15V SUPPLY
DG-06	CCGE/D RANGE ID	DG-13	CCGE -10V SUPPLY
DG-07	CCGE/D GAUGE OUT		

AG-01	CCGE/A GAUGE OUT
AG-02	CCGE/A RANGE ID

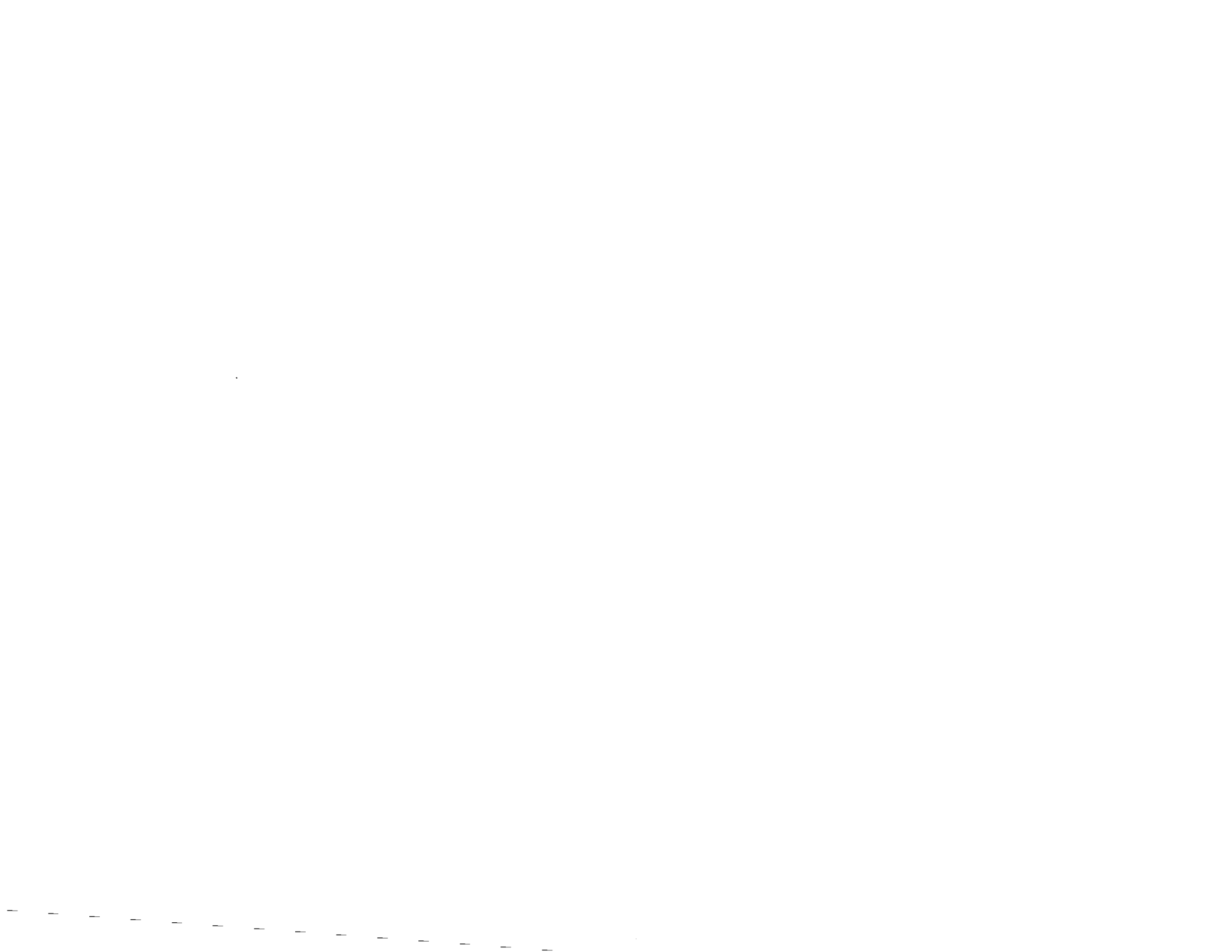

MSFN/MCC OPERATIONS

- GENERAL REQUIREMENTS
 - ◁ • CMD & TM PROCESSING
 - ◁ • SOFTWARE & DISPLAYS
- SPECIAL REQUIREMENTS
 - ◁ • POWER/THERMAL MANAGEMENT
 - ◁ • COMMAND FUNCTION STATUS BOARD
- DETAILED MCC MONITORING ACTIVITIES

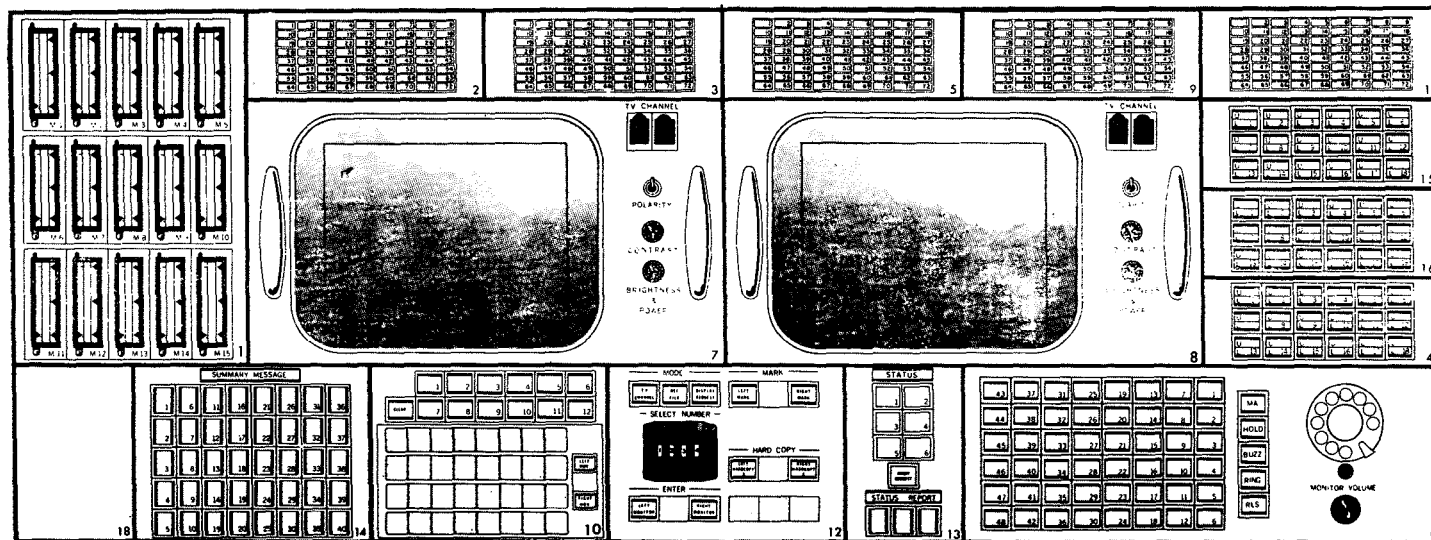

JAN 69 5178.16.1

COMMAND CONSOLE PLAN

TENTATIVE

- ALL COMMANDS FOR ALL ALSEPS FROM 1 CONSOLE
- USE UNIVERSAL COMMAND SYSTEM PANEL
 - ADDRESS: ANY ONE OF 8 ALSEP DECODERS
 - COMMAND: ANY ONE OF 100 DESIGNATIONS (PREFERABLY OCTAL 003 TO 174)
 - EXECUTE

- NOTES: (1) STANDARD VERIFICATION CHECKS WILL BE INCORPORATED;
AT LEAST, GROUND REJECT
- (2) NO AUTOMATIC RETRANSMIT PROCEDURE

APR 69 5178.16.2

TM PROCESSING AT MSFN SITES

ALSEP	MINIMUM REQUIREMENT	REMARKS
1,3	THROUGHPUT 2 DATA STREAMS MAX TO MCC, NO DECOMM REQ'D UNLESS THERE IS A DECISION TO MONITOR CMD VERIFICATION	TECHNIQUE FOR SENDING 2 STREAMS 1.06 KBPS EACH (NORMAL) ON ONE 2.4 KBPS LINE TBD. NOTE ALSEP FRAME = 0.60377 SEC
4	SAME AS ABOVE FOR MAJORITY OF TIME ADDITIONAL DECOMM REQMT FOR ASE 10.6 KBPS DATA RATE TO REDUCE IT TO < 2.4 KBPS & SEND TO MCC. DURING ASE OPERATIONS NO OTHER ALSEP DATA STREAM IS SENT TO MCC	85-FT SITE REQ'D FOR 10.6 KBPS DATA. EXCEPT FOR \approx 1 HR WHILE CREW IS ON LUNAR SURFACE, OTHER ASE OPERATIONS CAN BE SCHEDULED FOR CONVENIENCE

RECORDING REQ'D FOR MAX OF 3 ALSEPS SIMULTANEOUSLY PLUS RCVD STATION TIME. PLAYBACK REQMT'S TBD.

APR 69 5178.16.3

SOFTWARE

- ONE CDP COMMAND PROGRAM WILL SUPPORT ALL ALSEPS
- DECOM PROGRAMS VARY BETWEEN ALSEPS
- CAL CURVES VARY BETWEEN ALSEPS
- IN ADDITION TO VERY COMPLICATED SUBCOMMUTATION & SUPER COMMUTATION, MANY ALSEP PARAMETERS REQUIRE MORE COMPUTATION THAN ENG UNIT CONVERSION & LIMIT SENSING

DISPLAYS

FOR ALSEP 1

NOTE:

RETENTION OF HISTORICAL
DATA MUST BE MINIMIZED

SUBSYSTEM	REAL-TIME MONITORING				HISTORY	
	H/S PRINTER	METERS	ANALOG CHARTS	EVENT LIGHTS/CRT	H/S PRINTER	ANALOG CHARTS
CENTRAL STATION	L	H	B	D	L+D	B
PASSIVE SEISMIC	L		B+S	D	L+D	B+S
MAGNETOMETER	L		B	D	L+D	B
SOLAR WIND	A				A	
SUPRATHERMAL ION	L		B	D	L+D	B

LEGEND

L = LIMIT-SENSED PARAMETERS

H = HIGH-PRIORITY ANALOGS

D = DISCRETE

B = 8-CHANNEL

BRUSH RECORDER

(SCIENCE DATA > 1 SAMPLE/SEC)

S = SPECIAL SINGLE CHANNEL
DRUM RECORDERS WITH
VARIABLE BAND-PASS
FILTERS

A = ALL SWS DATA IN MATRIX
FORMAT (1 MATRIX = 28 SEC)

MULTIPLE-ALSEP DISPLAY PHILOSOPHY

DISPLAY	REMARKS
H/S PRINTER	SAME SUBSYSTEM ON DIFFERENT ALSEPS WILL USE SAME DISPLAY BUT DIFFERENT FORMATS
METERS & EVENT LIGHTS	EACH ALSEP WILL HAVE ITS OWN METERS & LIGHTS; HENCE THESE DISPLAYS WILL GIVE VALID DATA WHENEVER THEIR BIT STREAM IS BEING PROCESSED
ANALOG RECORDERS	SWITCHABLE IN REAL TIME BETWEEN DIFFERENT BIT STREAMS
CAPABILITY FOR PROCESSING 2 BIT STREAMS SIMULTANEOUSLY PROVIDES FOR PANEL LIGHT INDICATING OUT-OF-LIMITS WHENEVER IT IS DETECTED (EITHER ALSEP); ALSO INDICATES (1) WHICH ALSEP & (2) WHICH SUBSYSTEM	

POWER/THERMAL MANAGEMENT

REQUIREMENT

- RTG SUPPLIES CONSTANT POWER (NO MORE, NO LESS) AT A PARTICULAR VOLTAGE. OVERLOAD & UNDERLOAD ON RTG WILL CAUSE SERIOUS CHANGES IN RTG VOLTAGE
- PCU ADDS OR REMOVES SHUNT LOADS (UP TO 40 W) TO MAINTAIN CONSTANT SYSTEM LOAD ON RTG
- PDR LOADS CAN BE COMMANDED ON/OFF TO ASSIST PCU
- IF SYSTEM OVERLOAD OCCURS (WHEN PCU CANNOT UNLOAD ENOUGH), EXPERIMENTS ARE RIPPLED OFF AUTOMATICALLY TO REACH SATISFACTORY LOAD (TURN-ON BY COMMAND ONLY)
- IF SYSTEM UNDERLOAD (OR OVERLOAD) EXCEEDS PCU CAPABILITY, 12V LINE WILL GO UP (OR DOWN). AT 13V OR 11V, PCU 1 SWITCHES AUTOMATICALLY TO PCU 2 (PCU 2 HAS NO SWITCHBACK LOGIC & WILL OPERATE OUTSIDE 11-13V RANGE)

MCC ACTIVITIES

- MONITOR TM DATA FOR RESERVE POWER (PCU SHUNT) & ADJUST LOADS BY COMMAND TO AVOID RIPPLE-OFF, SWITCH-OVER, OR SYSTEM FAILURE
NOTE: (1) RESERVE POWER TM ONLY EVERY 54 SEC
(2) EXPER POWER PROFILES ARE VARIABLE & ASYNCHRONOUS
(3) NO TM OF INDIVIDUAL EXPER POWER
(4) PCU SHUNT LOAD VARIATIONS CAUSE NON-LINEAR (BUT PREDICTABLE) INTERNAL DISSIPATION IN PCU. THIS CAN CAUSE SERIOUS THERMAL DISTURBANCE OF CENTRAL STATION
- MAINTAIN, AS A FLIGHT CONTROL TOOL, A POWER/THERMAL FORECAST FOR SEVERAL HOURS IN ADVANCE & PARTICULARLY BEFORE MAJOR COMMAND OR TIMER EVENTS

JAN 69 5178.16.7

COMMAND FUNCTION STATUS BOARD

REQUIREMENT

- ALSEP 1 WILL USE 65 OF THE 100 AVAILABLE CMDs (REMAINDER MAY BE CONSIDERED INVALID)
- SIDE USES 5 CMDs MULTIPLEXED TO PERFORM 2 ONE-TIME & 15 REPETITIVE FUNCTIONS RESULTING IN 890 "CONFIGURATIONS"
- PSE & LSM USE SINGLE CMDs REPETITIVELY FOR MULTI-STATE FUNCTIONS
- CMDs INTERACT; EXAMPLE, ONE CMD ADDRESSES X, Y OR Z-AXIS WHILE THE NEXT CMD ACTIVATES THE ADDRESSED UNIT (PSE & LSM)
- LSM HAS 7-STATE FUNCTIONS; CMD MUST BE SENT 7 TIMES TO RETURN TO INITIAL STATE
- RESULT FOR LSM IS 20,000 "CONFIGURATIONS"
- INTERNAL TIMER PROVIDES SCHEDULED FUNCTIONS (BACKUP TO EXISTING CMDs) & INTERNAL PROTECTION CAUSES UNSCHEDULED SWITCHING

APR 69 5178.16.8

DETAILED MONITORING ACTIVITIES

- **ALSEP START-UP ACTIVITIES**
 - EXPERIMENT TURN-ON
 - TYPICAL EXPER CHECKOUT
(EXAMPLE, PSE)
- **TYPICAL ALSEP 1 MCC OPERATIONS**
 - FUNCTIONAL CHECKS
 - CRITICAL PARAMETERS

JAN 69 5178.16.9

EXPERIMENT TURN-ON

ALSEP 1

- CHECK S/N RATIO AT MSFN
- SYNC & DECOM AT MCC
- CMD BACK-UP DATA MODES AS REQUIRED
- CMD EXPERIMENT 2 OPER (LSM)
- VERIFY RECEIPT & EXECUTION OF CMD
- CONFIRM POWER LOAD & RESERVE POWER STATUS
- CMD EXPERIMENT 1 OPER (PSE)
- VERIFY CMD EXECUTION & POWER STATUS AS ABOVE
- CONTINUE FOR EXPERIMENTS 3 & 4 (SWS & SIDE)
- CMD DUST DETECTOR ON
- VERIFY PRESENCE OF DUST DETECTOR DATA
- CONFIRM POWER STATUS

TYPICAL EXPERIMENT CHECKOUT

(EXAMPLE, PSE)

- CHECK SCIENTIFIC & ENGINEERING DATA OF THE PSE
- UNCAGE PSE (MAY OCCUR PRIOR TO LM ASCENT)
- LEVEL THE PSE
- CALIBRATE THE PSE
- CHECK TEMPERATURE OF THE PSE
- COLLECT BASELINE PSE DATA

DEC 67 5178.16.11

TYPICAL ALSEP 1 MCC OPERATIONS

POST 45 DAYS

1. BRING BIT STREAM IN BUILDING, DECOM, PROCESS, & BRING UP DISPLAYS; MEANWHILE, VERIFY THAT CMD PANEL IS HOT
2. CHECK CMD FUNCTION STATUS FOR CHANGES SINCE END OF PREVIOUS MONITORING PERIOD
3. COMPARE POWER/THERMAL STATUS TO FORECAST
4. OBSERVE CENTRAL STATION PARAMETERS FOR OUT-OF-LIMITS CONDITIONS OR OTHER ANOMALIES; IF ANY EXIST, LOG STATUS, DETERMINE CAUSES, & CMD AS APPROPRIATE
5. EXAMINE PSE FOR SATISFACTORY DATA (1.2 SEC); SEND CORRECTIVE CMDs, IF NECESSARY
6. EXAMINE LSM DATA (9.66 SEC) FOR PROPER OPERATION & SETTINGS; CMD AS REQUIRED
7. DETERMINE WHETHER SWS IS FUNCTIONING PROPERLY BY OBSERVING FULL DATA CYCLE (7.6 MIN); NO FUNCTIONAL CMDs TO SWS EXCEPT POWER OPER/STBY/OFF
8. EXAMINE SIDE DATA (FULL CYCLE \approx 1 HR) FOR PROPER OPERATION & MEASUREMENT RANGES; ADJUST BY CMD, IF NECESSARY

NOTES

- INDICATED TIMES ARE FOR ONE CYCLE OF DATA AT NORMAL BIT RATE
- MAINTAIN LOG OF ALL CMDs SENT & STATUS CHANGES
- INDICATED TASKS DO NOT HAVE TO BE SERIAL

JAN 69 5178.16.12

TRANSMITTER CHECK

- CHECK XMTR A CRYSTAL & HEAT SINK TEMPERATURES
- CHECK RF OUTPUT POWER LEVELS
- SWITCH TO BACKUP XMTR, IF REQUIRED
- CHECK XMTR B TEMPERATURES & POWER LEVELS AS ABOVE

DEC 67 5178.16.13

DIAGNOSTIC CHECKS

- CHECK LEVEL OF RECEIVED POWER AT MSFN STATION
- CHECK PRELIMITING SIGNAL LEVEL OF ALSEP RCVR
- DETERMINE CENTER FREQUENCY OF ALSEP RCVR BANDPASS
- DETERMINE RF LEVEL OF ALSEP RCVR LOCAL OSCILLATOR
- CHECK FOR PRESENCE OF 1 KHz SUBCARRIER
- CHECK OUTPUT VOLTAGES OF DUST DETECTOR

TEMPERATURE CHECKS AND THERMAL CONTROL

- CHECK CENTRAL STATION TEMPERATURES
- CHECK RTG TEMPERATURES
- CHECK DUST DETECTOR TEMPERATURES
- CMD CENTRAL STATION HEATER ON/OFF, AS REQUIRED

POWER SUPPLY STATUS CHECK

- VERIFY THAT PCU 1 IS OPERATING
- CHECK PCU 1 TEMPERATURES
- CHECK PCU 1 OPERATING VOLTAGES
- CHECK POWER RESERVE STATUS
- CMD POWER DISSIPATION RESISTORS ON/OFF AS REQUIRED
- SWITCH TO PCU 2 ONLY IF FAILURE IS IMMINENT
- CHECK ADC CALIBRATION

CRITICAL CENTRAL STATION PARAMETERS

EQUIPMENT	CONTINGENCY	CORRECTIVE ACTION
POWER	<ol style="list-style-type: none"> 1. RTG HOT & COLD FRAME TEMPS ABNORMALLY HI OR LO 2. PCU SHUNT CURRENT HI OR LO 3. ABNORMAL PCU TEMPS OR VOLTAGES 	<ol style="list-style-type: none"> 1. MAY BE UNDER LOAD OR OVERLOAD BUT PROBABLY INCIPENT FAILURE & NO CORRECTIVE ACTION; COLLECT MAX DATA IN TIME REMAINING 2. UNDERLOAD OR OVERLOAD. ADJUST PDR & SWITCH EXPR OPER/STBY TO LOCATE CAUSE 3. ADJUST LOADS & PREPARE TO SWITCH PCU 2 IF SITUATION DETERIORATES
DATA	<ol style="list-style-type: none"> 1. LOSS OF CARRIER, MODULATION OR SYNC 2. WEAK OR NOISY SIGNAL 3. LOSS OF 6 OR 15 ANALOG CHANNELS 4. SUBCOMM DATA NOT OK 5. NON-ZERO IN CMD VERIF WORD WHEN NO CMD WAS SENT 6. ABNORMAL TEMPS IN COMPONENTS (OR ENTIRE CENTRAL STATION) 	<ol style="list-style-type: none"> 1. SWITCH TO ALTERNATE XMTR OR DATA PROCESSOR 2. SWITCH TO LOW BIT RT & TROUBLE SHOOT (LSM DATA INVALID INLBR) 3. MULTIPLEXER MALF; SWITCH TO ALTERNATE DATA PROCESSOR 4. SWITCH DATA PROCESSORS 5. INCIPIENT DECODER LOCKOUT; SWITCH TO ALTERNATE DATA PROCESSOR BEFORE SENDING ANY OTHER CMDS 6. SWITCH TO REDUNDANT EQUIP (MAN HTR ON/OFF)

CRITICAL PASSIVE SEISMIC PARAMETERS

CONTINGENCY	CORRECTIVE ACTION	COMMENTS
1. INSTRUMENT OFF-LEVEL (INDICATED BY TIDAL DATA) 2. SEISMIC DATA OFF SCALE OR INSIGNIFICANT 3. ERRATIC TIDAL DATA	1. CMD LVL, AS NECESSARY 2. ADJUST AMPLIFIER GAINS 3. CMD PSE FILT OUT	1. SINCE LEVEL SHOULD CHANGE SLOWLY (IF AT ALL) ANY CMD LVL SHOULD BE CLEARED WITH PI 2. SEE NOTE 3. WITH FILT OUT, TIDAL DATA SHOULD BE SAME AS SEISMIC
4. ABNORMAL TEMPS 5. POSSIBLE OUT-OF- CALIBRATION	4. CMD PSE HTR A/M & REG- ULATE TEMPS MANUALLY (PSE CAN OVERHEAT QUICKLY, THIS ACTION IS URGENT) 5. CMD CALIBRATIONS (TIMER ON SHORT PERIOD)	4. AUTO/MAN CMD HAS 4 STATES & HTR CAN BE SWITCHED FULL ON OR FULL OFF; CAN ALSO SWITCH ALL PWR OFF IF TEMPS ARE RISING RAP- IDLY 5. CALIB INTERVALS TBD
NOTE: AVOID SENDING ANY COMMANDS DURING SIGNIFICANT SEISMIC ACTIVITY		

APR 69 5178.16.18

CRITICAL MAGNETOMETER PARAMETERS

CONTINGENCY	CORRECTIVE ACTION	COMMENTS
<ol style="list-style-type: none"> 1. SCIENCE DATA NEAR FULL-SCALE, NEAR ZERO, OR OFF-CENTER 2. ERRATIC OR TOO FREQUENT FLIP/CAL 3. SCIENCE DATA NOT OK 4. NON-UNIFORM OR UNEXPECTED SENSOR TEMPS 5. OTHER ABNORMAL TEMPS 	<ol style="list-style-type: none"> 1. ADJUST GAINS & OFFSETS AS NECESSARY 2. CMD ALSEP TIMER INHIBIT & FLIP/CAL BY LSM CMD 3. CMD LSM FILT IN/OUT 4. CMD LSM T CTLXY (SEE NOTE) 5. NO CORRECTIVE ACTION, TURN EXPR OFF IF IT ENDANGERS ALSEP 	<ol style="list-style-type: none"> 1. POSSIBLE DUE TO CHANGES IN LUNAR ENVIRONMENT (NOTIFY PI PROMPTLY) 2. DURING INTERMITTENT MONITORING FLIP/CAL BY TIMER (EVERY 12 HR) CAN BE DETECTED FROM SENSOR POSITION TM 3. BYPASS (REMOVAL) OF FILTER RESULTS IN ROUGH, BUT USABLE, DATA 4. SWITCHES THERMAL CONTROL BETWEEN SENSOR HEADS (EITHER CAN BE SELECTED) 5. NO THERMAL CONTROL OVERRIDE & NO STBY HTR (IF LSM IS NOT OPERATING, IT HAS NO POWER)
<p>NOTE: FOR BEST OPERATION, FLIP/CAL MUST BE PERFORMED WHENEVER SENSOR TEMP CHANGES 3° C</p>		

CRITICAL SIDE PARAMETERS

CONTINGENCY	CORRECTIVE ACTION	COMMENTS
1. SIGNIFICANT CHANGE IN DISTRIBUTION OF SCIENCE DATA 2. MAJOR DECREASE IN MEASURED FLUX 3. OUT-OF-CALIBRATION 4. ABNORMAL TEMPS	1. ADJUST SAMPLING MODE (INTERNAL PROGRAMS STEP THROUGH A RANGE; VARIOUS MODE CMDs DELETE PORTIONS OF THIS RANGE) 2. CMD X10 INTEGRATION 3. CMD CALIBRATION 4. CMD EXPER STBY OR OFF IF RISING RAPIDLY	1. POSSIBLY DUE TO CHANGE IN LUNAR ENVIRONMENT (NOTIFY PI PROMPTLY); NON-NORMAL MODES MAY SHORTEN TIME FOR COMPLETE DATA CYCLE 2. MAKES FULL CYCLE \approx 10HR 3. NORMAL MODE INC CAL EVERY 2.5 MIN BUT OTHER MODES MAY NOT 4. NO THERMAL CONTROL OVERRIDE
OTHER CMDs ALLOW PORTIONS OF THE EXPERIMENT TO BE TURNED ON/OFF INDEPENDENTLY BUT THERE IS NO CORRECTIVE ACTION FOR MOST OUT-OF-LIMITS CONDITIONS OR HANG-UPS CCIG PORTION OF SIDE HAS TEMP MEASUREMENT IN CONTACT WITH LUNAR SURFACE (THE ONLY ONE ON ALSEP)		

ALSEP ABBREVIATIONS

a	ampere	ASTRO	Astronaut
AB	Analog Bistatic (Discrete) Measurement (Code)	AT	Analog Temperature Parameter (Code)
AC	Alternating Current	ATTEN	Attenuator
ACCEL	Acceleration	AUTO	Automatic
ACCPT	Accept	AWG	American Wire Gage
ACK	Acknowledge	AZ	Azimuth
ACN	Ascension Island (MSFN)	B1	Bottom Location of Structure Temperature Measurement
A/D	Analog to Digital	BATT	Battery
ADC	Analog-to-Digital Converter	BER	Bit Error Rate
ADD	Address	BIOMED	Biomedical
ADJ	Adjustment	BKG	Background
ADV	Advance	BPS	Bits per Second
AE	Analog Electrical Parameter (Code)	BTU	British Thermal Unit
AEC	Atomic Energy Commission	C	Centigrade
A/F	Automatic/Forced	CAL	Calibrate, Calibration
AGC	Automatic Gain Control	CAP	Capacitor
AIM	Aiming	CCGE	Cold Cathode Gauge Experiment (Part of SIDE)
ALGE	Apollo Lunar Geological Equipment	CCGE/A }	Analog and Digital ID Read Out from CCGE
ALHT	Apollo Lunar Hand Tools	CCGE/D }	
ALSD	Apollo Lunar Surface Drill	CCIG	Cold Cathode Ion Gauge (Instrument Portion of CCGE)
ALSEP	Apollo Lunar Surface Experiments Package	CDP	Command Data Processor
ALT	Alternate	C/E	Central Electronics (of ASE)
AMPL	Amplifier	CENT STA	Central Station
AMP	Amperes-pl is AMPs Amplifier(s)	CFE	Contractor-Furnished Equipment
AMU	Atomic Mass Unit	CG	Center of Gravity
ANT	Antenna	CH	Change, Channel (Data)
APPROX	Approximate, Approximately	CHAN	Channeltron; used in CPE as: CHAN/1 Channeltron P/S #1 CHAN/2 Channeltron P/S #2 CHAN/HI Channeltron Voltage Increase ON CHAN/LO Channeltron Voltage Increase OFF
A/PW	Analog to Pulse Width		
AR	Analog Temp. of RTG (Code)		
ARC	Ames Research Center		
ASE	Active Seismic Experiment		
ASI	Apollo Standard Initiators		
ASSY	Assembly		

JAN 69 5178.A.1

CIRC	Circular	DEF	Deflection
CKT	Circuit-CKTS (P1)	DEG	Degrees
CKT BKR	Circuit Breaker	DEM0D	Demodulator
CLD	Cold	DET	Detect, Detection, Detector
CMzyx	Continuous Motor (Connections on LSM)	DIAM	Diameter
CM		DIR	Direction
CMD	Command (CMDs, Commands) Commanded	DIR/V	Direction and Speed (used on PSE)
CNB	Canberra, Australia (MSFN)	DISSIP	Dissipation
CNT(s)	Count(s)	DIST	Distribution
CNTR	Counter	DSS	Data Subsystem; components include:
CO	Continuous (Motor Circuit on LSM)	DSS/A	Analog Data Processor
COAX	Coaxial Cable	DSS/D	Digital Data Processor
CON	Connector	DSS/PROC	Complete Data Processor (Redundant)
COMM	Communications		
CONFIG	Configuration	E	East
CONN	Connection	ea	Each
CONT	Controlled-Control (Cont.=Continued)	EGFU	Electronics/Gimbal Flip Unit (LSM)
CONV	Converter	EL	Elevation
CPE	See CPLEE	ELECT	Electrical
CPLEE	Charged-Particle Lunar Environ- ment Experiment (Also CPE)	ELEV	Elevation
CPS	Cycles per Second	EM	Electromagnetic
CRT	Cathode Ray Tube	EMI	Electromagnetic Interference
CST	Central Station Timer	ENG	Engineering
CTL	Control	EOS	Electro-Optical Systems (Xerox)
CUR	Current	EPS	Electrical Power Subsystem
CV	Command Verification	EQUIP	Equipment
CVR	Cover	EQUIV	Equivalent
CRV/S	Cover and Seal (used on SIDE)	ev	Electron Volts
CW	Clockwise	EVA	Extravehicular Activities (or Astronaut)
db	Decibels	EXP	Experiment
dbm	Decibels, with reference to one milliwatt	EXPER	Experiment
DC	Direct Current	EXT	External
DDP	Digital Data Processor	F	Fahrenheit, Flight
DECOM	Decommutate, Decommutation	FEP	Fluorinated Ethylene Propylene
		FET	Field Effect Transistor

FILT Filter
 FLD Field
 FLIP/CAL Flip/Calibrate (LSM)
 FREQ Frequency
 FT Foot
 FTT Fuel Transfer Tool
 FWD Forward
 g Gravity
 GAL Gravity (used as μ gal on PSE)
 GDS Goldstone, California (MSFN)
 GDT Gradient Sensor Delta Temperatures (HFE)

PROBE	1		2	
	UPPER	LOWER	UPPER	LOWER
HIGH SENSITIVITY	GDT11H	GDT12H	GDT21H	GDT22H
LOW SENSITIVITY	GDT11L	GDT12L	GDT21L	GDT22L

GEN Generator
 GEO Geophone
 GFE Government-Furnished Equipment
 GHz GigaHertz
 GLA Grenade Launch Assembly (a component of ASE)
 GMBL Gimbal
 GMT Greenwich Mean Time
 GND Ground
 GSFC Goddard Space Flight Center
 GT Gradient Sensor Ambient Temperatures (HFE)

PROBE	1		2	
	UPPER	LOWER	UPPER	LOWER
CODE	GT11	GT12	GT21	GT22

GWM Guam (MSFN)
 HAW Kauai Island, Hawaii (MSFN)
 HBR High Bit Rate
 HECPA High Energy Curved Plate Analyzer (a component of SIDE)
 HFE Heat Flow Experiment
 HI High
 HK Housekeeping, High Conductivity (HFE)
 HORIZ Horizontal
 HR Hour
 H/S High Speed
 HTR Heater; on HFE there are two cases:
 HTR/HK High Conductivity Heater
 HTR/LK Low Conductivity Heater
 HV High Voltage
 Hz Hertz
 ID Identification
 IF Intermediate Frequency
 IN Input
 IN. Inch
 INC Including, Included, Increase
 INHIB Inhibit
 INST Instrument
 INSUL Insulation
 INT Internal
 INTEG Integrator
 ISO Prefix meaning "single"
 JPL Jet Propulsion Laboratory
 K Kelvin, Kilo
 KBPS Kilobits per Second
 kev Kilo-Electron Volts
 KHz KiloHertz
 KSC Kennedy Space Center
 KV Kilovolt
 KW Kilowatt

LB	Pound (LBs, plural)	MS	Millisecond (also MSEC)
LBR	Low Bit Rate	MSB	Most Significant Bit
LECPA	Low Energy Curved Plate Analyzer (a component of SIDE)	MSC	Manned Spacecraft Center
LGE	Lunar Geological Equipment	MSEC	Millisecond
LK	Low Conductivity (HFE)	MSP	Measurement Sequence Programmer
LM	Lunar Module	MSFN	Manned Space Flight Network
LO	Low	MTG	Mounting
LOG	Logarithmic	MTR	Motor; on PSE, the three motors are MTRX, MTRY, and MTRZ
LP	Launch Phase, Long Period (PSE)	MUX	Multiplexer
LPDT _μ L	Low-Power Diode Transistor	MV	Millivolt
LSB	Least Significant Bit	mw	Milliwatt
LSM	Lunar Surface Magnetometer	MW/CM ²	Milliwatts per Square Centimeter
LV	Low Voltage	m _μ	Millimicron
LVL	Level	N	North, Number
M	Meter	NA	Nano Amperes, Not Applicable
MA	Milliampere	NASA	National Aeronautics and Space Administration
MAD	Madrid (MSFN)	NBR	Normal Bit Rate
MAP	Message Acceptance Pulse	NEG	Negative
MAX	Maximum	NG	No Good
MCC	Mission Control Center	Ni	Nickel
MDE	Mode	NO.	Number
MEAS	Measurement	NORM	Normal
MECH	Mechanical, Mechanism	NRC	National Research Corporation
MEG	Million (as in Megohm)	NRZ	Non-Return to Zero
MFG	Manufacturing	OPER	Operate, Operation, Operating, Operator, Operational
MHz	MegaHertz	OR'ED	Processed through an "OR" gate
MIN	Minimum, Minute	O/S	Offset
MISC	Miscellaneous	OSC	Oscillator
MODE	Operating Modes are defined as follows: for HFE <u>MODE/G</u> Gradient Mode MODE/HK High Conductivity Mode MODE/LK Low Conductivity Mode	O/T	One-Time
MON	Monitor(ing)	OUT	Output
		PARAM	Parameter
		PCB	Printed Circuit Board
		PCM	Pulse Code Modulation
		PCT	Percent

PCU Power Conditioning Unit
 PDR Power Dissipation Resistor
 PDU Power Distribution Unit
 Pe Probability of Bit Error
 PERF Performance
 PET Package Elapsed Time (from RTG Plug-In)
 PF Picofarad
 PHYS/AN Physical Analyzer (a component of the CPLEE)
 PKG Package
 PL Plane
 PLSS Portable Life Support System
 PM Phase Modulation
 POS Positive
 POSN Position
 PRA Parabolic Reflector Array (of LSM)
 PREAMP Preamplifier
 PRELIM Preliminary
 PRE/LIM Pre-Limiting
 PRE/REG Pre-Regulator (a component of the SIDE Power Supply)
 PRI/ST Primary Structure
 PROP Proportional
 PROC Processor
 PROG Programmer
 P/S Power Supply
 PSE Passive Seismic Experiment; also:
 PSE/LP Long Period Sensors
 PSE/SP Short Period Sensor
 PSE/LP/SP Long and Short Period Sensors
 Long Period Sensors are further defined as PSE/X, PSE/Y, and PSE/Z while PSE/XY denotes the two horizontal long period sensors

PSI Pounds per Square Inch
 PSIA Pounds per Square Inch Absolute
 Pu 238 Plutonium Isotope
 PWR Power
 QTY Quantity
 R Resistor (used as R1 and R2)
 RAD Radians
 RAD/SEC² Radians per Second per Second
 RCVD Received
 RCVR Receiver
 RDT Ring Sensor Delta Temperature (HFE)

PROBE	1		2	
BRIDGE	UPPER	LOWER	UPPER	LOWER
CODE	RDT11	RDT12	RDT21	RDT22

RE Reference (Motor Circuit on LSM)
 REF Reference
 REG Regulator, Register
 REP Repetition
 REQD Required
 REQMT Requirement (REQMTs, pl)
 RES Reserve
 RMX, Y, Z Reference Motor (connections on LSM: e.g., RMX)
 RNG Range
 ROT Rotation, Rotate
 RST Reset
 RT Rate (as in BIT RT, CNT RT, etc.)
 RT Ring Sensor Ambient Temperatures (HFE)

PROBE	1		2	
BRIDGE	UPPER	LOWER	UPPER	LOWER
CODE	RT11	RT12	RT21	RT22

RTC	Real Time Command	SLA	Spacecraft/LM Adapter
RTE	Real Time Event	SMEK	Summary Message Enable Key-board
RTG	Radioisotope Thermoelectric Generator	S/N	Signal to Noise
RTN	Return	SNAP	Systems for Nuclear Auxiliary Power-Type 27
S	South	SNSR	Sensor
S/C	Spacecraft	SOS	Space Ordnance Systems, Inc.
SCAS	Southwest Center for Advance Studies	SP	Split Phase, Short Period (PSE)
SCI	Scientific, Science	SPEC	Specification
SEC	Second	SPST	Single Pole, Single Throw
SEL	Select, Selector, Selection	SRC	Specimen Return Container
SEQ	Sequence, Sequential; used on HFE as: SEQ/FUL Full Sequence SEQ/P1 Probe 1 Sequence SEQ/P2 Probe 2 Sequence Used on ASE as: SEQ/S Sequential	S/T	Structure/Thermal
		STA	Status, Station (Cent Sta)
		STBY	Standby
		SW	Switch
		SWS	Solar Wind Spectrometer
		SYNC	Synchronization (abbreviated "SY" on APOLLO)
SEQ	Scientific Equipment (a Bay in LM)	T	Temperature (also used as "Thermal" on ALSEP)
SIDE	Suprathemal Ion Detector Experiment; also: SIDE/A Analog and Digital SIDE/D Voltages or Readings SIDE/HE High Energy Analog Data SIDE/LE Low Energy Analog Data SIDE/LHE Least Significant High Energy Digital Data SIDE/LLE Least Significant Low Energy Digital Data SIDE/MHE Most Significant High Energy Digital Data SIDE/MLE Most Significant Low Energy Digital Data	T ₀	Zero Reference Time of Timer
		TAPLE	Telemetry for Apollo Passive Lunar Experiments
		TBD	To Be Determined
		TC	Thermocouple; on HFE, four cable ambient temperatures are read on each Probe: TC1A, TC1B, TC1C, TC1D (Probe 1) TC2A, TC2B, TC2C, TC2D (Probe 2)
		TEMP	Temperature (TEMPs, pl)
		TERM	Terminal
		TM	Telemetry
		TMR	Timer
		TNT	Trinitrotoluene
		TORR	Unit of Pressure (one Millimeter of Mercury)
SIG	Signal	TRANS	Transmitter

JAN 69 5178.A.6

TRW	TRW, Inc. (Manufacturer)
TV	Television
UHT	Universal Handling Tool
USGS	United States Geological Survey
UV	Ultraviolet
V	Volt, Velocity (used to indicate "Speed" on PSE in "LVL DIR/V")
Vcc	Transistor Supply Voltage
VCO	Voltage Controlled Oscillator
VDC	Volts Direct Current
VERT	Vertical
V/FILT	Velocity Filter
V/M	Volts per Meter
VSWR	Voltage Standing Wave Ratio
W	Watt, West
W ₁ , W ₂ , W ₃	Wall Locations of Structure Temperatures
WD	Word (WDs, pl)
WRT	With Respect To
WT	Weight
XMTR	Transmitter
XYZ	Axes of LSM, where XYO indicates X, or Y, or neither
XYO	
YR	Year
γ	Gamma (unit of Magnetic Flux)
μ GAL	Microgal
μ SEC	Microsecond

