



*Get DIF for
ISSUE reports*

REPORT OF APOLLO 13 REVIEW BOARD

**APPENDIX B - REPORT OF MISSION
EVENTS PANEL**

**APPENDIX C - REPORT OF MANUFACTURING
AND TEST PANEL**

APPENDIX D - REPORT OF DESIGN PANEL

**APPENDIX E - REPORT OF PROJECT
MANAGEMENT PANEL**

FACILITY FORM 602	<u>N70-78429</u>	
	(ACCESSION NUMBER)	(THRU)
	<u>495</u>	<u>None</u>
	(PAGES)	(CODE)
<u>TMX-66472</u>		
(NASA CR OR TMX OR AD NUMBER)	(CATEGORY)	

NATIONAL AERONAUTICS AND SPACE ADMINISTRATION

APPENDIX B
REPORT OF MISSION EVENTS PANEL

CONTENTS

Part		Page
	APPENDIX B - REPORT OF MISSION EVENTS PANEL	
B1	<u>TASK ASSIGNMENT</u>	B-1
B2	<u>PANEL ORGANIZATION</u>	B-3
B3	<u>SUMMARY OF EVENTS</u>	B-5
B4	<u>PRELAUNCH AND MISSION EVENTS PRIOR TO THE ACCIDENT</u>	B-11
	LAUNCH COUNTDOWN	B-11
	Mechanical Build-up and Gas Servicing	B-11
	Cryogenic Servicing	B-13
	Spacecraft Closeout and Terminal Count	B-25
	LAUNCH AND TRANSLUNAR COAST PHASE PRIOR TO THE ACCIDENT	B-26
	Launch and Flight Summary	B-26
	Spacecraft Systems Operation	B-27
	Hydrogen Low Pressure Master Alarm	B-30
	Cryogenic Tank Destratification	B-31
B5	<u>INCIDENT EVENTS</u>	B-37
	INTRODUCTION	B-37
	STATUS OF THE SPACECRAFT PRIOR TO THE ACCIDENT	B-45
	FAN TURNON AND ASSOCIATED ELECTRICAL ANOMALIES	B-45
	OXYGEN TANK PARAMETERS FROM 55:53:30 UNTIL LOSS OF TELEMETRY	B-51
	LOSS OF TELEMETRY	B-54

Part		Page
	SPACECRAFT EVENTS AT THE TIME OF TELEMETRY LOSS	B-56
	CHANGES IN SPACECRAFT DYNAMICS	B-62
	TEMPERATURE CHANGES OBSERVED IN SERVICE MODULE	B-67
	FAILURE OF CRYOGENIC OXYGEN SYSTEM	B-67
	OPERATION OF THE ELECTRICAL POWER SYSTEM . . .	B-80
B6	<u>POSTINCIDENT EVENTS</u>	B-83
	IMMEDIATE RECOVERY	B-83
	Chronology of Spacecraft Reconfiguration Actions	B-84
	Evaluation of Electrical and Cryogenic Oxygen Problem	B-88
	Maintenance of Attitude Control	B-92
	Lunar Module Activation	B-97
	PLANS AND ACTIONS TAKEN TO RETURN THE CREW TO EARTH	B-100
	Consumables and Systems Management Actions	B-102
	Return to Earth Trajectory Control	B-111
	Entry Procedures and Checklist Definition	B-120
B-7	<u>INSTRUMENT SYSTEM CHARACTERISTICS</u>	B-127
	OXYGEN TANK TEMPERATURE MEASUREMENT	B-127
	OXYGEN TANK QUANTITY INSTRUMENTATION	B-130
	OXYGEN TANK 2 PRESSURE INSTRUMENTATION	B-134

Part		Page
	PULSE CODE MODULATION SYSTEM DESCRIPTION . . .	B-137
	MISSION CONTROL	B-152
	<u>REFERENCES</u>	B-158

This page left blank intentionally.

PART B1

TASK ASSIGNMENT

Panel 1 was assigned the task to develop a detailed and accurate chronology of mission events directly related to the flight of Apollo 13. This event sequence would then form a baseline of data for analytical use by Panel 1, other Panels, and the Review Board.

To provide such a chronology, Panel 1 worked to produce a consolidated sequence of all data whether derived from telemetry records, crew observations, inflight photographs, air-to-ground communications, or other sources of information. Of special significance to Panel 1 was the requirement to correlate data taken from different sources, such as crew observations and telemetry, in order to provide greater assurance of the validity of data wherever possible.

In order to provide meaningful boundary conditions for its work, Panel 1 divided its effort into three areas:

1. Preincident events, which covered the flight from countdown to the time of the inflight accident.
2. Incident events, which covered the flight from approximately 55 hours and 52 minutes to the conclusion of immediately related data events.
3. Postincident events, which covered the subsequent mission period to splashdown.

In each of the three areas the main purpose of the Panel was to provide the most efficient presentation of events for the Board's use in reviewing, evaluating, and interpreting the significance of mission events. Consequently, Panel 1 devoted a considerable portion of its time to the task of data interpretation and verification. As was intended from the Charter of the Board, the primary focus of the Panel's work was the period of time during which the service module encountered serious inflight difficulties, and its presentation of data reflects this particular emphasis.

This page left blank intentionally.

PART B2

PANEL ORGANIZATION

Panel 1 was chaired by Mr. Francis B. Smith, Assistant Administrator for University Affairs, NASA Headquarters, Washington, D.C. The Board Monitor was Mr. Neil Armstrong from the Manned Spacecraft Center. Additional Panel Members were:

Mr. John J. Williams, Kennedy Space Center, for preincident events

Dr. Thomas B. Ballard, Langley Research Center, for incident events

Mr. M. P. Frank, Manned Spacecraft Center, for postincident events

Although each of the above specialized in one phase of the Panel's total assignment, the Panel acted as one unit in the review and assessment of data and in the analysis and interpretation of those events identified with the accident.

This page left blank intentionally.

PART B3

SUMMARY OF EVENTS

Apollo 13 was launched on schedule from Kennedy Space Center at 2:13:00 e.s.t. on April 11, 1970. The crew consisted of James E. Lovell, Commander (CDR); John L. Swigert, Command Module Pilot (CMP); and Fred W. Haise, Lunar Module Pilot (LMP). The preflight countdown was routine and although some malfunctions and anomalies occurred during boost and earlier portions of the flight, none except the premature cutoff of one of the S-II engines was considered at the time to be of a serious nature.

At about 55:54, the crew had just completed a television broadcast; CMP Swigert was in the left seat of the command module, LMP Haise was in the lunar module, and CDR Lovell was in the CM lower equipment bay, when all three heard a loud bang. At about the same time in Mission Control in Houston, the Guidance Officer (GUIDO) noted on his console display that there had been a momentary interruption of the spacecraft computer. He told the Flight Director, "We've had a hardware restart. I don't know what it was." At almost the same time, CDR Lovell, talking to Mission Control, said, "I believe we've had a problem here." Also at about the same time, the Electrical, Environmental, and Communications Engineer (EECOM) in Mission Control noticed on his console display the sudden appearance of limit sensing lights indicating that a few of the telemetered quantities relating to the spacecraft's cryogenic, fuel cell, and electrical system had suddenly gone beyond pre-set limits. Astronaut Swigert in the command module, noting a master alarm about 2 seconds after the bang, moved from the left seat to the right seat where he could see the instruments indicating conditions of the electrical system, and noticed a caution light indicating low voltage on main bus B, one of the two busses supplying electrical power for the command module. At that time, he reported to Mission Control, "We've had a problem. We've had a main B bus undervolt." At the same time, however, he reported the voltage on fuel cell 3, which supplied power to main bus B, looked good and assumed that the main bus B undervolt condition had been a transient one. However, 2 or 3 minutes later, when another master alarm sounded, LMP Haise moved into the right-hand seat to recheck the fuel cells and noted that two of the three fuel cells (no. 1 and no. 3) were showing no hydrogen or oxygen flow and no electrical output and that fuel cell 2 was carrying the command module's total electrical load through bus A. Bus B was dead. In addition, several other electrical and cryogenic system abnormalities were evident.

Detailed studies and analyses of telemetry records made since the flight indicated that during the 90 seconds before the "bang", several abnormal events occurred. At about 55:53:23, within a few seconds after the crew had turned on two fan motors which stir the supercritical cryogenic

oxygen in oxygen tank no. 2, electrical "glitches" (transient high-amplitude current and voltage fluctuations) occurred which could be indicative of momentary electrical short circuits. Analyses of telemetry data also indicate that first one fan motor and then the other probably became disconnected from the electrical bus concurrently with the glitches. Thirteen seconds after the first glitch (16 seconds after the fans were turned on) the pressure in oxygen tank no. 2 started to rise; during the next 24 seconds it increased from a normal value of 891 psia to 954 psia; it remained at that pressure for approximately 21 seconds and then again increased to a maximum value of 1008 psia (approximately the pressure at which the relief valve was set to open), at which point the relief valve apparently opened and pressure began decreasing. During the last 23 seconds of this period, during the second oxygen pressure increase, telemetry indicated that oxygen tank no. 2 temperature also began to increase sharply; and concurrently with the sudden temperature rise, the oxygen tank no. 2 quantity gage, which had been inoperative for the previous 9 hours, began to show fluctuating readings. At about 90 seconds after the start of the pressure rise, telemetry transmission from the spacecraft was suddenly interrupted for a period of 1.8 seconds.

Putting all of this and other information together with the service module photographs taken later by the crew and with subsequent changes in the condition of the spacecraft system leads to a determination that immediately before and during this 1.8-second interval the following things happened:

1. The oxygen tank no. 2 system failed, leading to loss of all oxygen pressure.
2. The service module panel covering bay 4 blew off, possibly producing the "bang" heard by the crew.
3. The spacecraft's velocity changed by 0.5 fps.
4. Transmission of telemetry from the spacecraft was interrupted (possibly caused by the panel striking and damaging the high-gain antenna through which data were being telemetered).
5. Various valves in the reaction control systems (RCS) were shocked closed (contributing to some difficulties in maintaining automatic attitude control).
6. Valves controlling oxygen flow to fuel cells 1 and 3 were shocked closed (leading to failure of both fuel cells 2-1/2 minutes later for lack of oxygen).
7. Oxygen tank no. 1 started leaking oxygen.

8. Venting of oxygen produced forces on the spacecraft which the automatic stabilization system counteracted by firing opposing spacecraft reaction control thrusters.

9. Various sensors or their wiring were damaged to cause subsequent erroneous readings.

These changes occurred so rapidly, of course, that neither the crew nor the mission controllers could have had a clear picture of specifically what had happened.

In the Mission Control Center, after the 1.8-second data loss, the EECOM first suspected an instrumentation failure since earlier in the flight (46:40) the oxygen tank no. 2 quantity gage had failed and since other pressures, temperatures, voltages, and current readings were so abnormal (e.g., more than 100 percent or less than 0 percent of full scale) as to appear unrealistic. They appeared more indicative of an instrumentation failure than of real quantities. The Flight Director also initially believed, from the information available to him in the Control Center, that the difficulty was electrical or electronic in nature. Consequently, Mission Control Center's initial efforts during the first 3 or 4 minutes after the malfunction were to validate instrument readings and to identify a possible instrumentation failure. During the next several minutes, both the flightcrew and the ground controllers worked at switching fuel cell bus power configurations in an attempt to understand what had happened and to get fuel cells 1 and 3 back on line. They determined that fuel cell 1 had no output and disconnected it from the bus. Later they also disconnected fuel cell 3 for the same reason. For several minutes they connected the command module's entry battery to bus A to aid fuel cell 2 in supplying electrical power and to insure against further failures due to low voltage.

Shortly after the malfunction, while the Apollo 13 crew and the EECOM were trying unsuccessfully to restore electrical power output from fuel cells 1 and 3, the Guidance and Navigation Officer (GNC) reported an unusually high level of attitude control thruster activity on the spacecraft. This added to their problems, since it indicated other abnormal conditions aboard the spacecraft and used excessive thruster fuel. Consequently, during the next hour the ground control and the crew were required to pay a great deal of attention to maintaining attitude control of the spacecraft and to identifying and eliminating the cause of the instability. At the same time, the Flight Director began to suspect that the genesis of the problem might lie in the RCS, rather than in the high-gain antenna or instrumentation.

During this period (about 14 minutes after the accident) CDR Lovell reported, "...it looks to me, looking out the hatch, that we are venting something. We are venting something out into space.....it's a gas of some sort." He subsequently described this venting as extremely heavy and unlike anything he had seen in his three previous space flights.

For about 1 hour 45 minutes after the accident, the crew and ground controllers wrestled with electrical problems caused by oxygen supply and fuel cell failures and with attitude stability problems caused by the venting of oxygen, the shock closing of thruster system valves, and electrical system failures. During this period they went through a series of control system reconfigurations until automatic control was finally established at 57:32. In the meantime, as it became more apparent that the loss of oxygen from oxygen tank no. 1 could not be stopped and that fuel cell 2 would soon expire, the LM was powered up (57:40), LM telemetry was turned on (57:57) and attitude control was transferred from the CM to the LM (58:34). At 58:40, 2 hours 45 minutes after the accident, the CM was completely powered down.

One of the main concerns then was to make the trajectory changes that would return the spacecraft safely to Earth within the lifetime of the onboard consumables--water, oxygen, thruster fuel, and electric power. At the time of the accident the spacecraft was on a trajectory which would have swung it around the Moon (about 21 hours after the accident) and returned it to Earth where it would have been left in a highly elliptical orbit about the Earth with a perigee (nearest approach to Earth) of about 2400 miles. Four trajectory correction burns were made during the remainder of the flight as illustrated in figure B6-9.

61:30 - A 38 fps incremental velocity (delta V) burn using the descent propulsion system (DPS) engine and the LM primary guidance and navigation system (PGNS). This burn was performed 16 hours before they swung around the Moon, and was targeted to place the spacecraft on a trajectory which would return it to the atmospheric Earth reentry corridor rather than the 2400-mile perigee.

79:28 - A 861 fps delta V burn using the DPS 2 hours after swinging around the Moon to speed up return to Earth by about 9 hours (143 versus 152 g.e.t.) and to move the landing point from the Indian Ocean to the Pacific Ocean where the primary recovery forces were located.

105:18 - A 7.8 fps delta V burn using DPS to lower perigee altitude from 87 miles to about 21 miles.

137:40 - A 3.2 fps delta V final burn using LM RCS thruster to correct for small dispersions in previous burns and assure that the spacecraft would reenter in the center of its entry corridor.

During the remainder of the flight there were several other unusual situations which the crew and Mission Control successfully contended with. The use of electrical power aboard the LM had to be managed very carefully to conserve not only the LM batteries but also the water supply, since water was used to dissipate heat generated by the electrical equipment. The LM LiOH was not adequate to remove carbon dioxide for three men for the duration of the return trip, so a method was devised to circulate the LM cabin oxygen through the CM's LiOH filters. Since the CM had to be used for reentry, its main bus B had to be checked out very carefully to assure that there were no electrical shorts and the CM entry battery which had been used earlier to supply power for the ailing CM had to be recharged from the LM batteries.

Several actions essential to reentry and landing were undertaken during the last 9 hours of the flight as illustrated in figure B6-10. The SM was jettisoned a few minutes after the last midcourse correction, about 4-1/2 hours before reentry. In viewing and photographing the SM, the crew realized for the first time the extensiveness of the physical damage (panel blown off, Mylar strips hanging from antenna, etc.). At about 2-1/2 hours before reentry, the CM's inertial platform was powered up and aligned and the LM was jettisoned about 1/2 hour later. Reentry was at 142:40 and splashdown at 142:54 g.e.t.

This page left blank intentionally.

PART B4

PRELAUNCH AND MISSION EVENTS PRIOR TO THE ACCIDENT

This section of the report contains significant events prior to the accident with emphasis placed on the spacecraft and particularly on the cryogenic system. It starts with the launch count (T - 98:00:00) and ends prior to the significant events of the accident (55:52:00).

LAUNCH COUNTDOWN

Countdown operations for both the command service module (CSM) and lunar module (LM) were started at approximately 10:00 a.m. e.s.t. on Monday, April 6, 1970. The start of the countdown was delayed approximately 8 hours because of a pad clear operation involving a special test of the LM supercritical helium (SHe) system. A timeline of significant countdown milestones is shown in figure B4-1.

Mechanical Build-up and Gas Servicing

Following completion of CSM powerup, water servicing, and securing of the LM SHe operation, installation of the CSM heavy ordnance initiators was started at approximately 3:00 p.m. e.s.t. The ordnance operation and remote resistance checks of the launch escape rocket initiators were completed by 9:30 p.m. e.s.t., April 6, after being slightly delayed to correct a mechanical interference problem (incorrect thread depth) with the initiator in the launch escape rocket motor. Combined CSM and LM helium and gaseous oxygen (GOX) servicing was started at 2:00 a.m. e.s.t. on April 7, and was successfully completed by noon that day. At this time, both the CSM and LM were functional at T - 66:00:00, at which point a built-in hold of 12 hours had been originally planned. As a result of the late countdown start, both the LM and CSM spacecrafts experienced only a 6-hour built-in hold.

From noon Tuesday, April 7, through 11:00 a.m. Thursday, April 9, mechanical build-up operations (panel closure, LM thermal blanket installation, etc.) were conducted on the CSM and LM. The CSM fuel cells were activated and preparations were completed for CSM cryo loading, that is, filling the cryogenic oxygen and hydrogen tanks. Details of this operation are covered below. During this time the LM SHe tank was initially loaded and a 24-hour cold soak period started. All of these operations were completed without a significant problem, with the

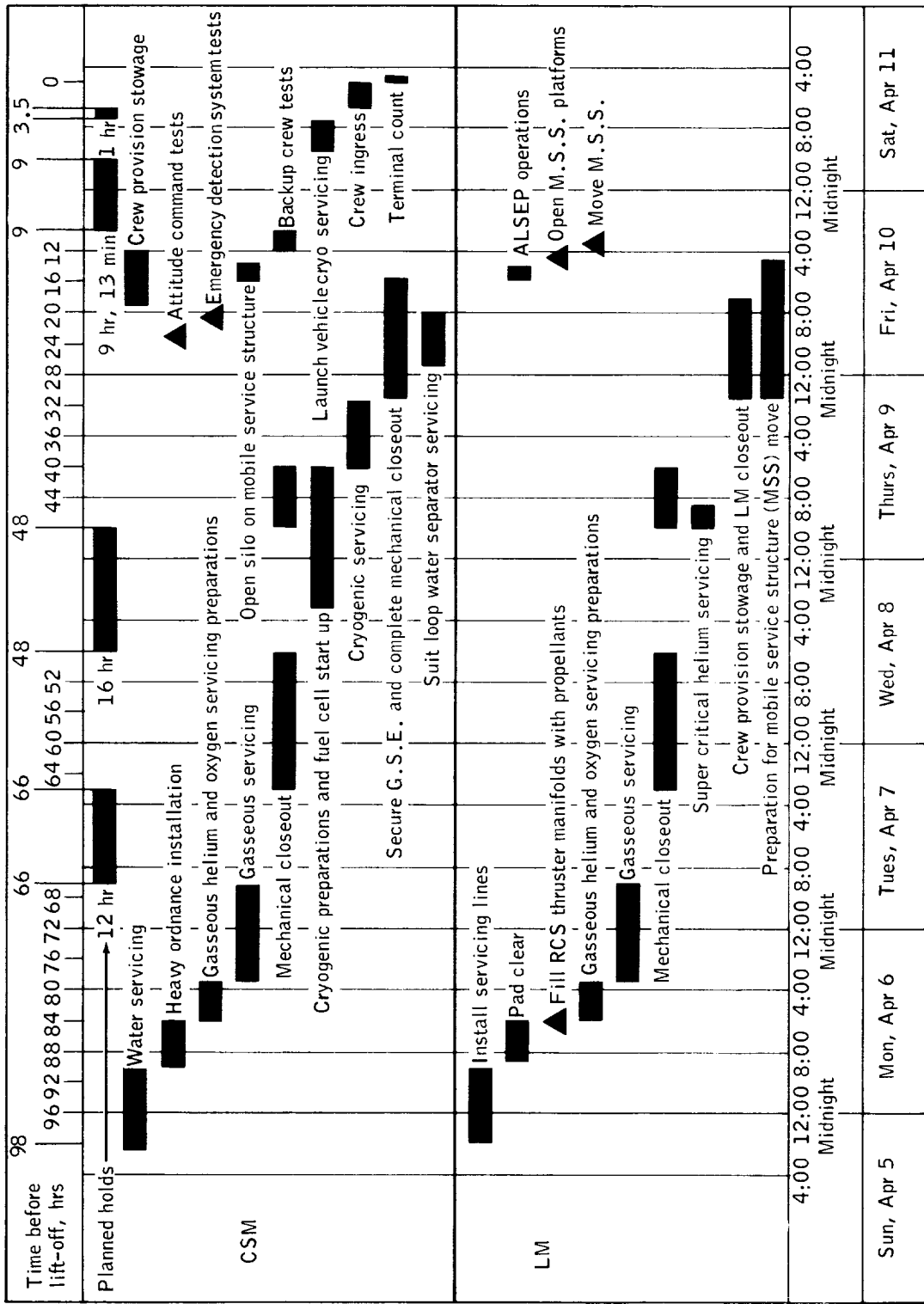

Figure B4-1.- Planned launch countdown timeline, e.s.t.

spacecraft progressing functionally from T - 66:00:00 to T - 41:00:00; including completion of the built-in hold at T - 66:00:00 and another planned 16-hour built-in hold at T - 48:00:00.

Cryogenic Servicing

CSM cryo loading or flowing liquid hydrogen and liquid oxygen was scheduled to be performed from 11:00 a.m. e.s.t. through 7:00 p.m. e.s.t. Thursday, April 9, 1970. A timeline of significant milestones, including preliminary preparations, is shown in figure B4-2. (See Appendix A, Part A5 for a description of the fuel cell and cryogenic systems.) The configuration of the cryogenic and fuel cell systems was as follows:

1. The fuel cell gaseous oxygen and hydrogen systems were at a pressure of 28 psia with oxygen and hydrogen gases. The fuel cells had been operated in the countdown demonstration test (CDDT) and were left pressurized with reactant gases (gaseous oxygen and hydrogen) to maintain system integrity between CDDT and countdown.

2. The oxygen and hydrogen tanks were at a pressure of 80 psia with oxygen and hydrogen gases. The tanks had been evacuated (less than 5mm Hg for 2 hours minimum) and serviced during CDDT, with reactant gas left in the system after detanking to maintain system integrity between CDDT and countdown.

3. The ground support equipment (GSE) lines were connected to the spacecraft and had been previously evacuated, pulse purged, and then pressurized with reactant gas to 80 psia. Purity samples taken of the gases from the GSE were within specification. The pressure-operated disconnects (POD's) that connect the GSE to the spacecraft had been leak checked at 80 psia with reactant gas and indicated no leakage.

4. The portable oxygen dewar used to service the spacecraft oxygen tanks was serviced on April 7, 1970. Liquid samples taken from the vent line of the dewar during servicing were within specification. All of the preceding activities were accomplished without undue delay or difficulty.

The first activity for the fuel cell and cryogenic system in the countdown started at approximately 3:00 p.m. e.s.t. on April 8, 1970. The move of the liquid hydrogen and liquid oxygen dewars from the cryogenic buildings to the pad had been completed. The primary oxygen, backup oxygen, and backup hydrogen dewars were located on the pad at the base of the mobile service structure (MSS) while the primary hydrogen dewar was moved to level 4A of the MSS. The hydrogen and oxygen GSE configuration is shown in figures B4-3 and B4-4, respectively.

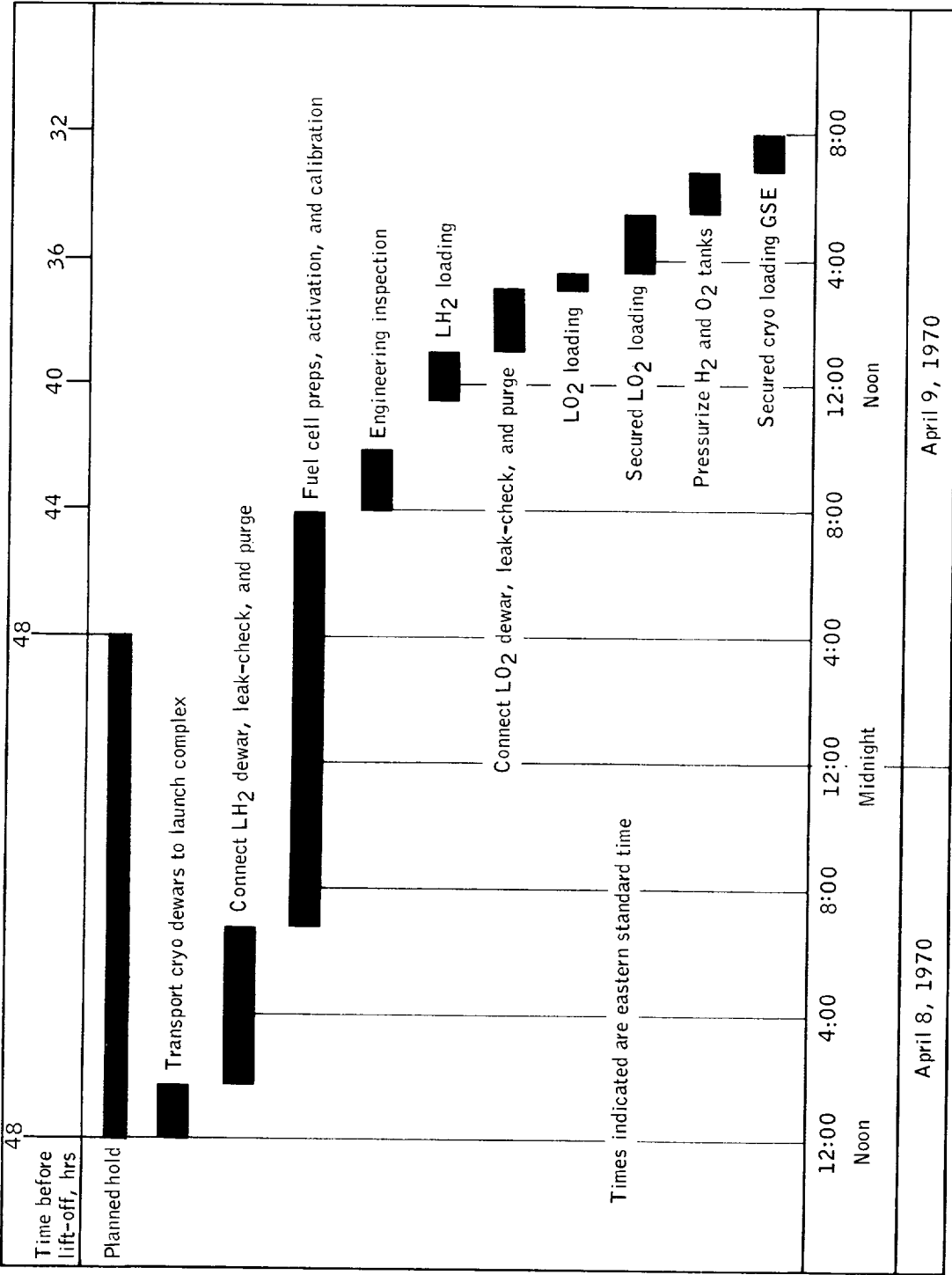

Figure B4-2.- Fuel cell activation and cryogenic servicing timeline.

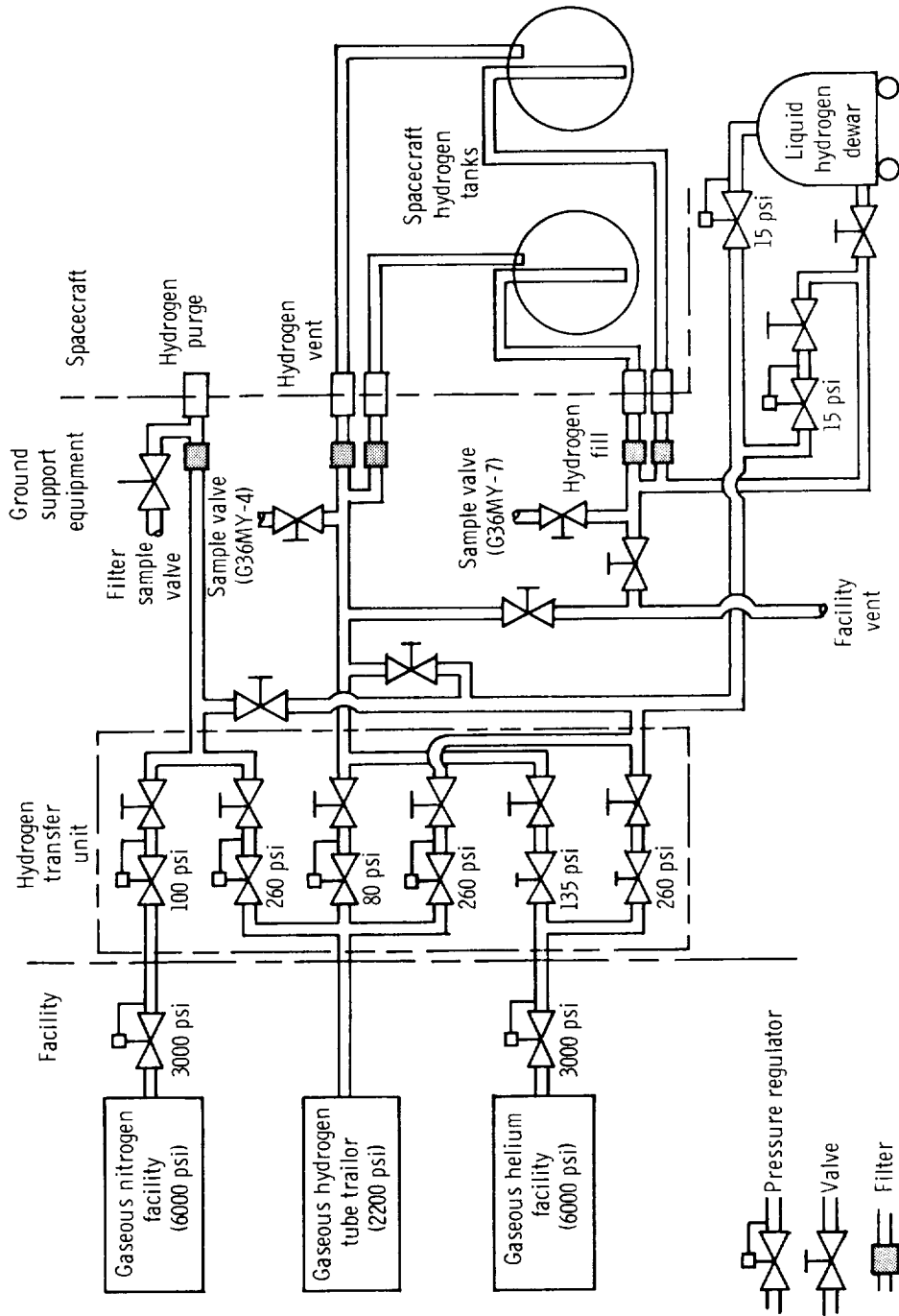

Figure B4-3.- Hydrogen servicing configuration.

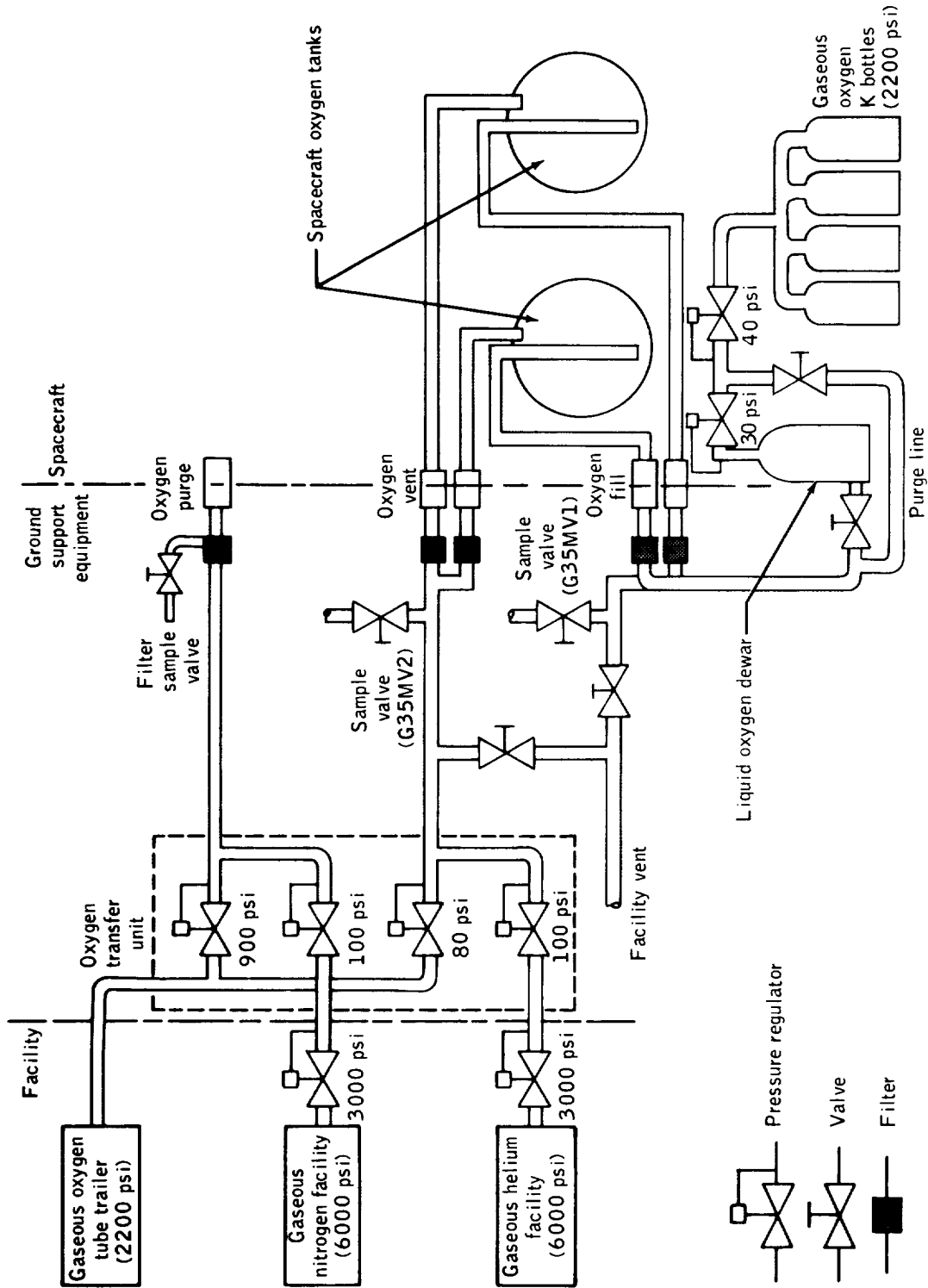

Figure B4-4.- Oxygen servicing configuration.

Pictures of the servicing dewars, valve boxes, and pressurizing equipment are shown in figures B4-5 through B4-10.

Dewpoint samples of the oxygen and hydrogen spacecraft tanks were obtained. This was accomplished by pressurizing the tanks with reactant gas to 80 psia through the vent line and then venting the tank back through the vent line and obtaining a moisture sample at the vent line sample valve. Both the oxygen and hydrogen tanks met the requirements that the moisture content be less than 25 parts per million (ppm). Oxygen tanks no. 1 and no. 2 read less than 2 ppm.

After the dewpoint samples of the tanks were obtained, sample bottles were installed on the tank vent lines. The sample bottles were flow purged with reactant gases at 80 psia for 5 minutes, followed by 10 pulse purges ranging in pressure from 80 psia to 20 psia.

The hydrogen dewar was then connected to the servicing GSE. The fill line between the dewar and the spacecraft was flow purged with 55 psia of helium gas for 15 minutes, and a moisture sample taken from the fill line. A sample result of 2 ppm was obtained. An additional flow purge using gaseous hydrogen at 55 psia was then performed for 10 minutes, followed by 13 pulse purges ranging in pressure from 55 psia to 20 psia (Note: This cleans the dead-end areas at the manifold).

The fuel cells were then pressurized to their operating pressure (62 psia oxygen and hydrogen). Heat was applied electrically to the fuel cells from external GSE to melt the potassium hydroxide. Fuel cell 3 heater current, supplied from GSE for heatup, was slightly low (1.2 amps vs. 1.4 amps). This heater current was adjusted after the heatup and calibration of the fuel cells was completed.

With the fuel cells at operating temperature (420° F) and pressures, a calibration test on each fuel cell was performed. Fuel cells were calibrated by applying loads in approximately 10-amp increments until a maximum current of 60 amps was reached while monitoring the output voltage. The fuel cell loads were supplied by GSE load banks. After calibration, the fuel cells were connected to the spacecraft busses and 40-amp GSE load applied to each cell for fuel cell water conditioning (approximately 4 hours). After these loads were removed from each fuel cell, 6-amp in-line heater loads with a 50-percent duty cycle were applied. With the fuel cells in this configuration a visual engineering inspection of the liquid hydrogen and liquid oxygen loading systems was performed with the exception of the liquid oxygen dewar, not yet connected.

Immediately prior to flowing liquid hydrogen, the spacecraft hydrogen and oxygen tank fans and quantity probe circuit breakers were

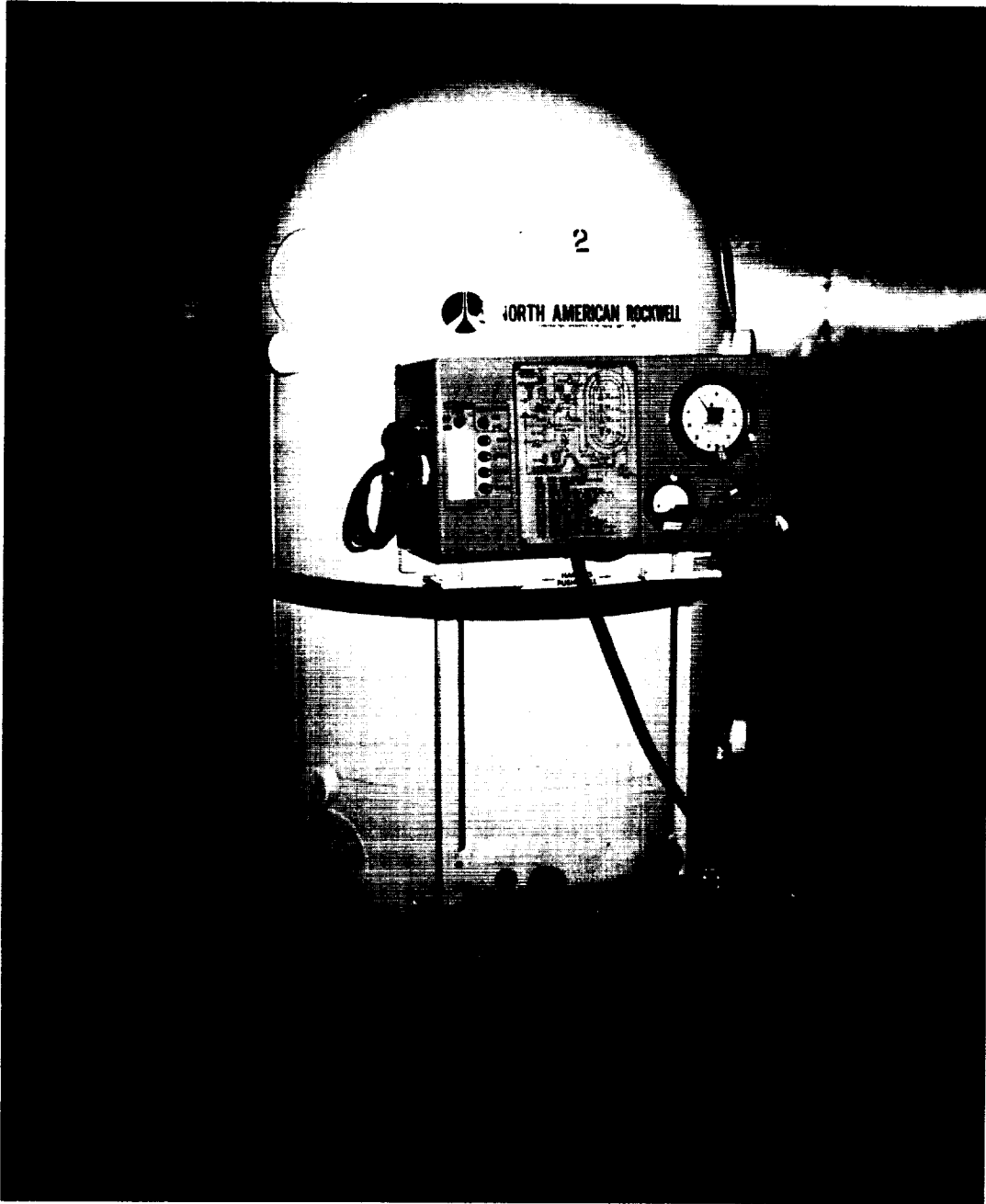

Figure B4-5.- Liquid hydrogen dewar.

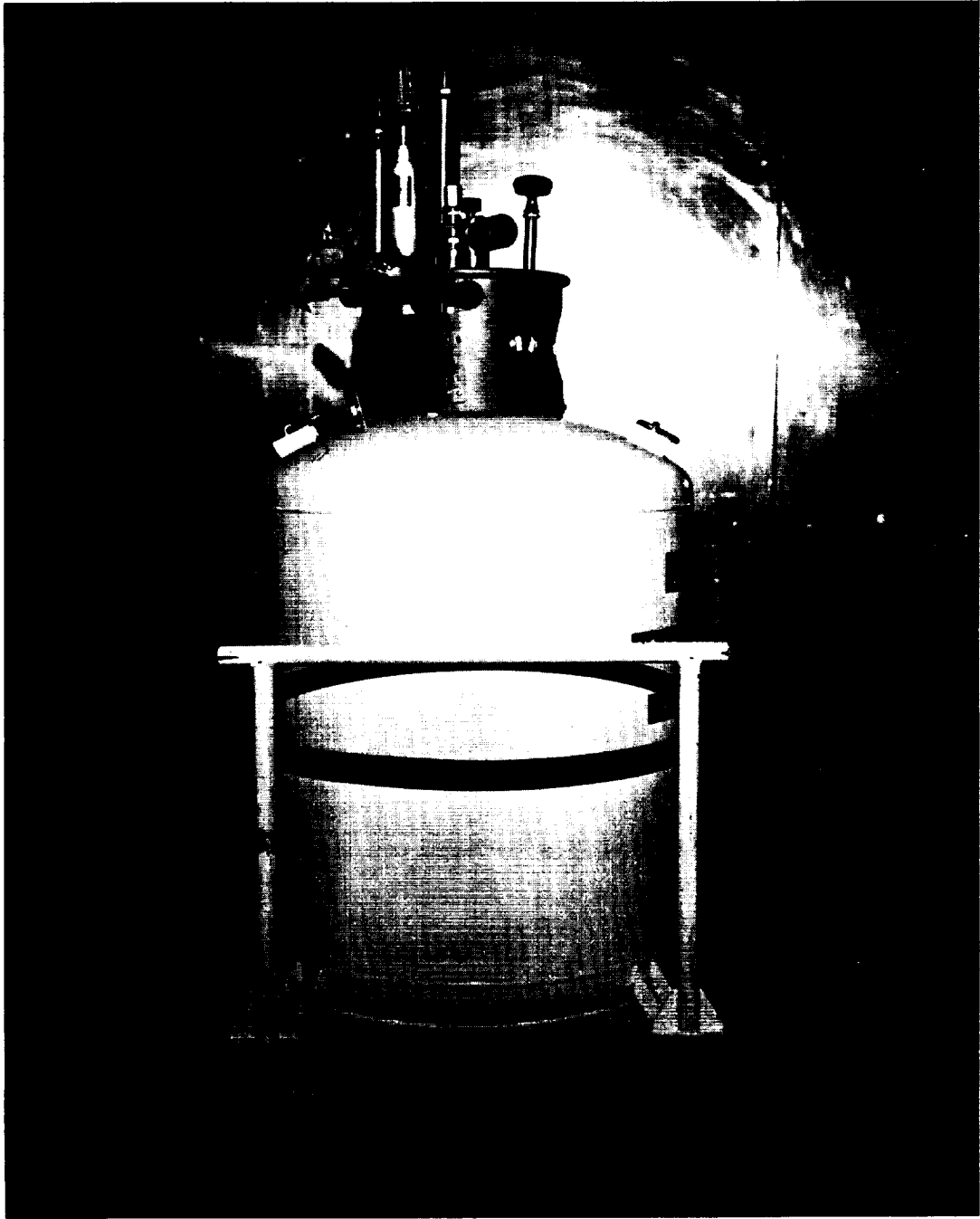

Figure B4-6.- Liquid oxygen dewar.

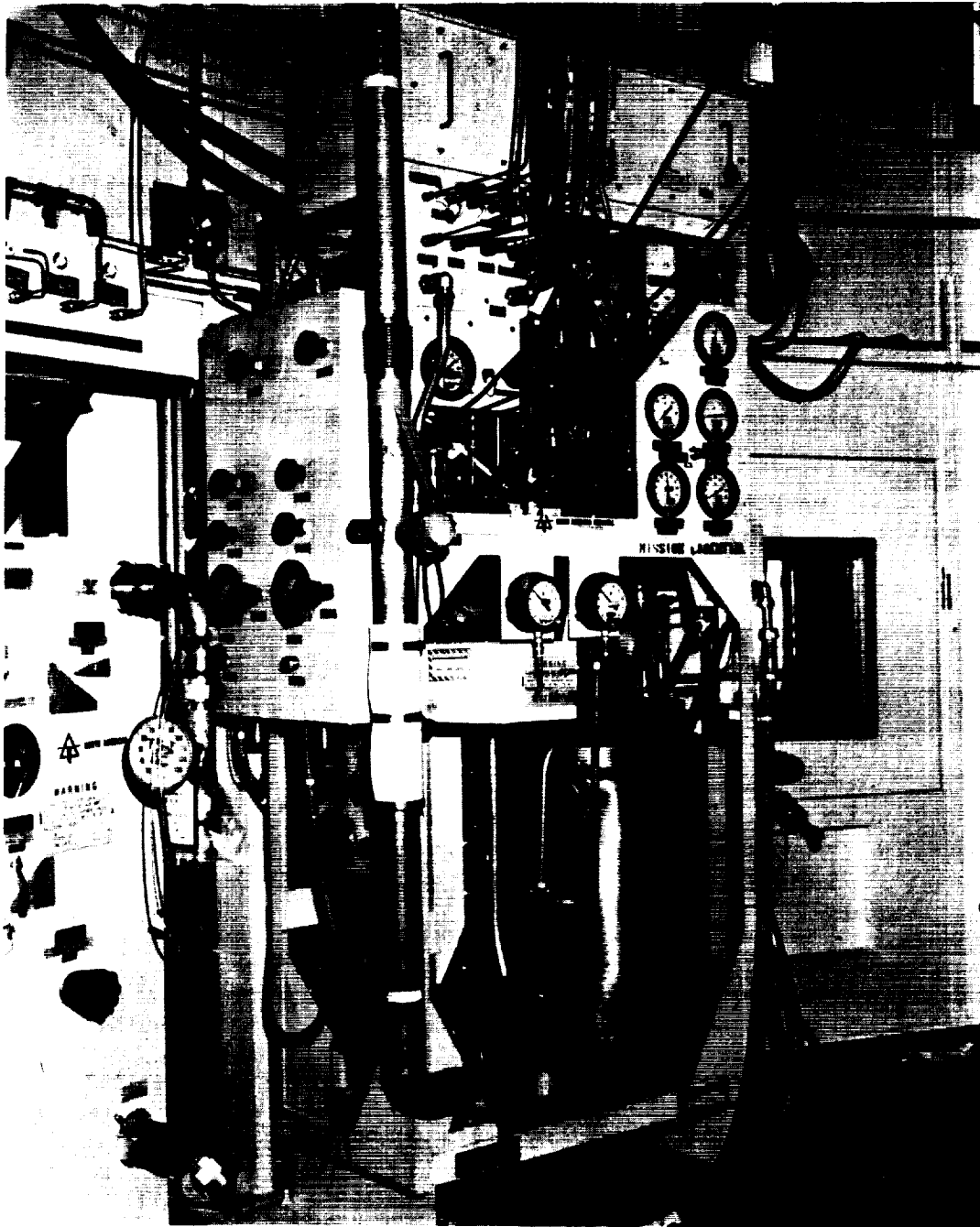

Figure B4-7.- Hydrogen valve box at Launch Complex 39.

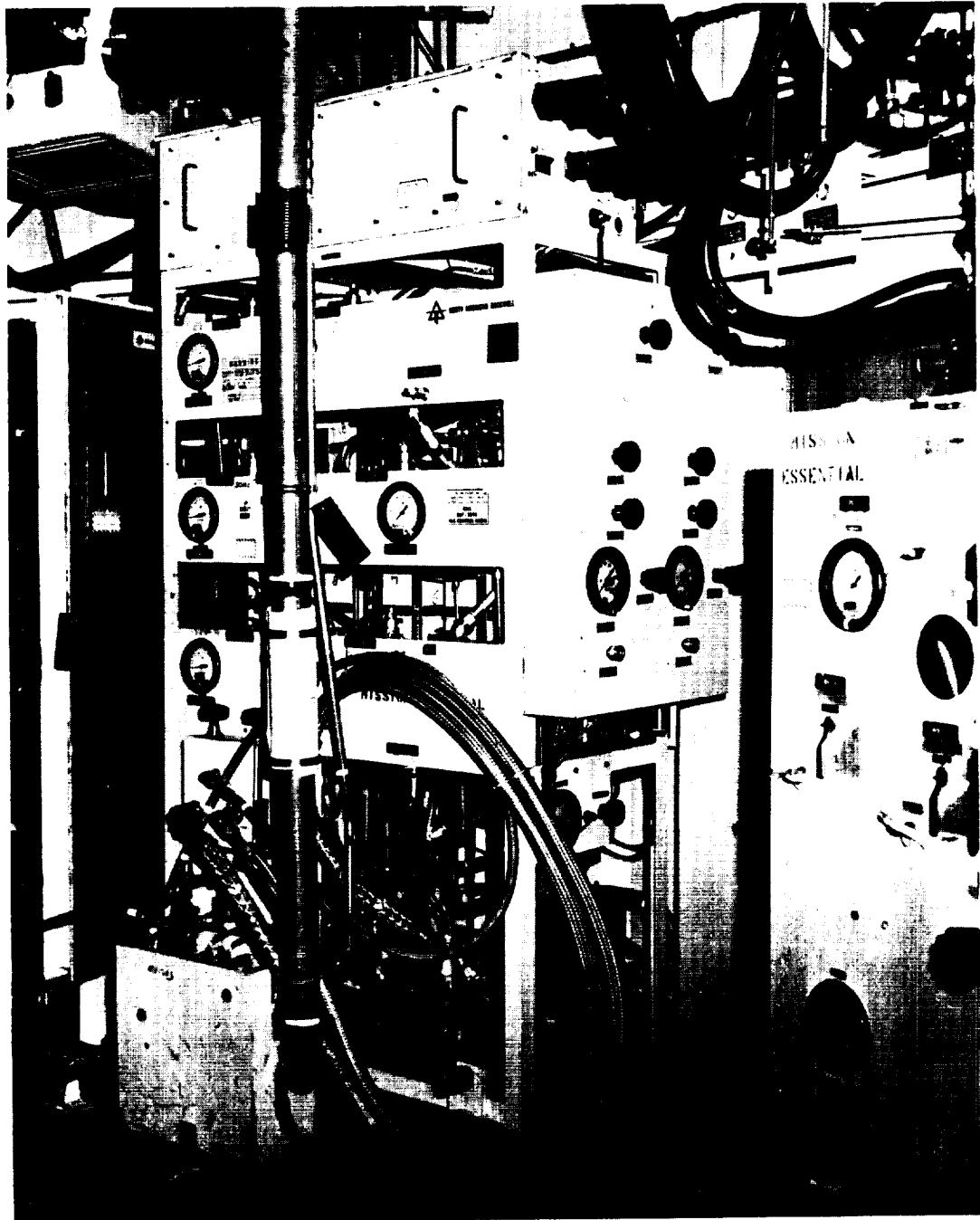

Figure B4-8.- Oxygen valve box at Launch Complex 39.

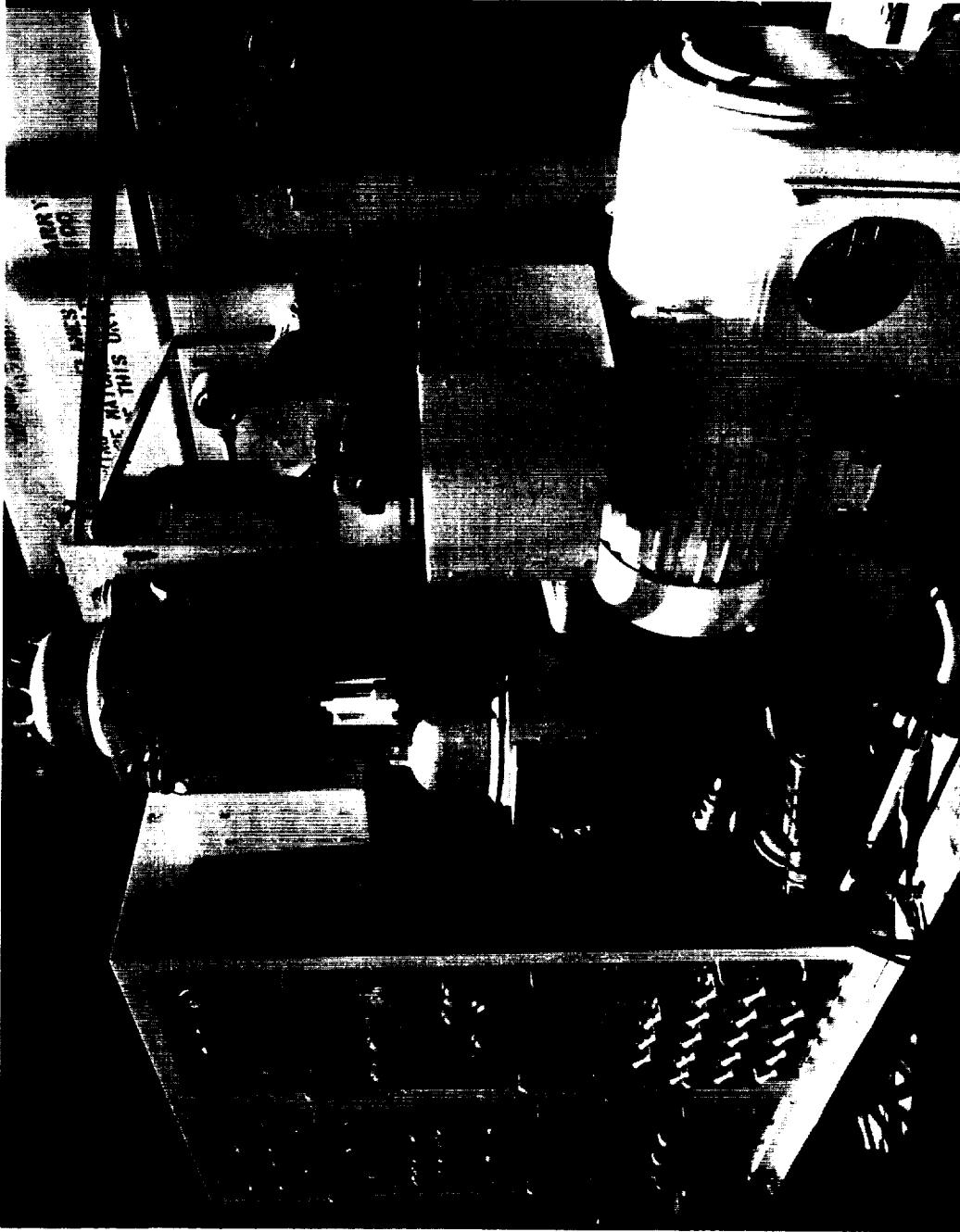

Figure B4-9.- Hydrogen transfer unit at Launch Complex 39.

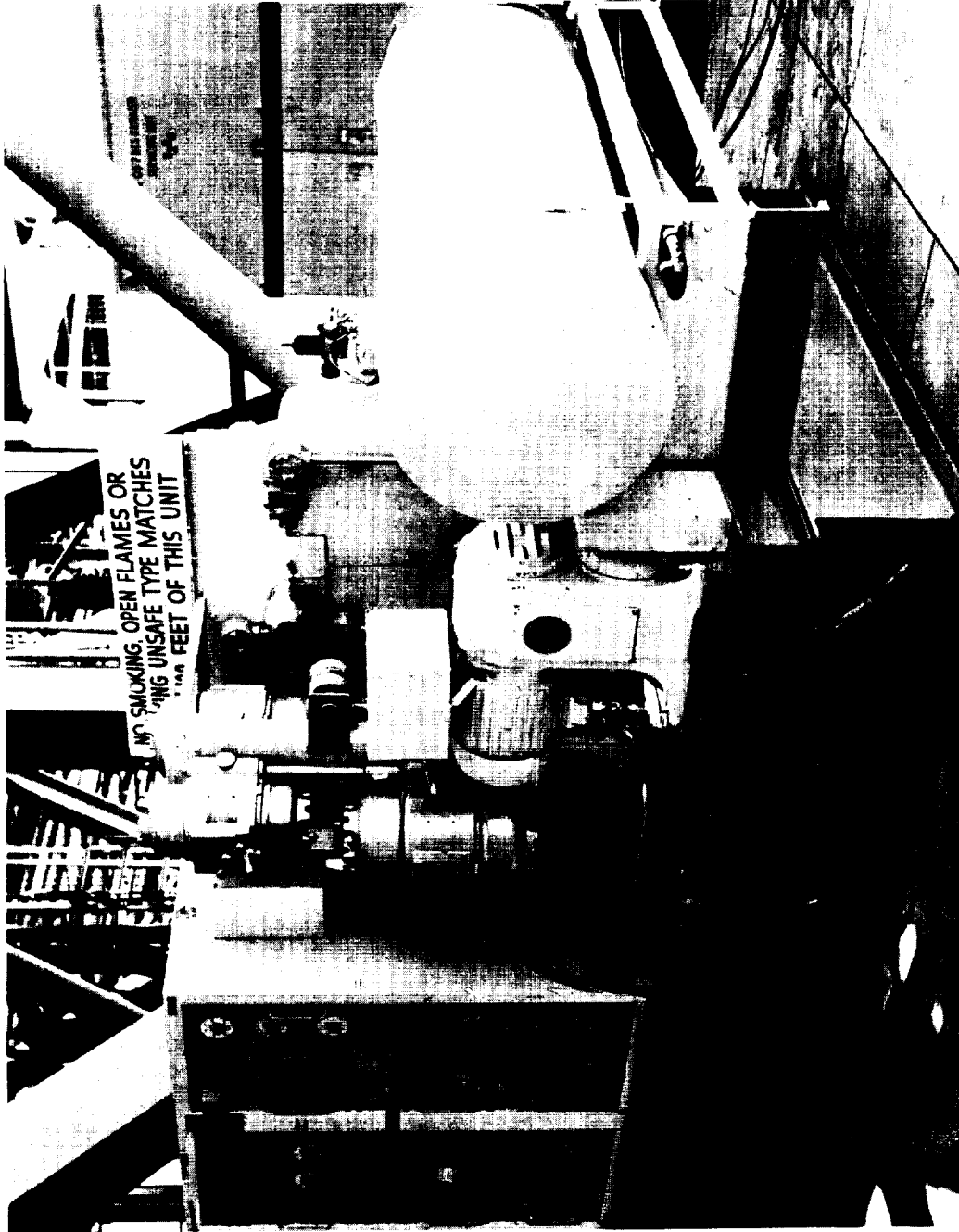

Figure B4-10.- Oxygen transfer unit at Launch Complex 39.

closed. (See Appendix A, Part A5, for description of the oxygen and hydrogen tanks.) The hydrogen dewar was pressurized to approximately 30 psia prior to servicing. Hydrogen was flowed through both tanks for 10 minutes (normal) prior to obtaining an increase in tank quantity. This period is required to chill the system. The flow rate during servicing was approximately 2.1 pounds per minute for 22 minutes (both tanks). The flow was stopped for 30 minutes when the tank quantity reached 85-percent and the dewar and spacecraft tanks vented to ambient pressure. The fans were turned off during this period. This time period is required to chill the hydrogen tank. The dewar was again pressurized to approximately 30 psia, and flow (at normal rates) began through the fill manifold detank line for 2 minutes to chill the GSE prior to then opening the spacecraft fill POD's. When the quantity gage stabilized (about 98-percent) the dewar pressure was increased to approximately 35 psia and the vent POD's closed, followed closely by the closure of the fill POD's. The GSE vent valve was closed simultaneously with the closing of the spacecraft vent POD's. This operation traps cold gas between the spacecraft vent POD's and the GSE vent valve. As the cold gas warms and expands, it is vented into the two sample containers connected to the vent line sample valve. The samples were analyzed for helium, nitrogen, and total hydrocarbons. Both samples were within specifications.

The hydrogen dewar was removed and the prime oxygen dewar was brought up to level 4A of the MSS. The oxygen dewar was connected to the servicing GSE. The fill line between the dewar and the spacecraft was flow purged with 55 psia of oxygen gas for 15 minutes, and a moisture sample taken from the fill line. A sample result of less than 2 ppm was obtained. After sampling, 13 pulse purges from a pressure of 55 psia to a slight positive pressure to maintain flow were performed. The spacecraft oxygen tank fans were turned on prior to oxygen flow. The oxygen dewar was pressurized to approximately 45 psia. Oxygen was flowed through both tanks for approximately 2 minutes (normal) before an indication was noted on the quantity probe. The flow rate during servicing was 25 pounds per minute for approximately 25 minutes (both tanks). After the tank quantity reached 100 percent, flow was continued for an additional 10 minutes, to further chill the tanks. The spacecraft vent POD's and the GSE vent were then closed, followed immediately by the closure of the fill POD's. The spacecraft tank fans were turned off at this time. The cold gas trapped in the vent line was sampled. The oxygen is sampled for helium, nitrogen, and total hydrocarbons. Both samples were within specification. The service module supply valve was opened to allow the CM surge tank to pressurize for flight.

While pressurizing the surge tank, fuel cell 1 was connected to dc bus A to minimize the usage of liquid hydrogen. A constant

flow from the liquid hydrogen tanks equal to the heat gained by the tank results in minimum liquid hydrogen usage. The load on the fuel cell was approximately 20 amps. This configuration was maintained until 4 hours before launch, at which time fuel cells 2 and 3 were connected to the busses. Fuel cells 1 and 2 were connected to bus A with fuel cell 3 supplying power to bus B. The fuel cells supplied power to the spacecraft from this time through launch.

Ground electrical power was supplied to the tank heaters to bring the tanks to flight pressure. The liquid oxygen system pressurization to approximately 935 psia and the liquid hydrogen system to approximately 235 psia was completed by 6:40 p.m. on April 9, 1970. The fuel cells were supplied by onboard reactants from this period through launch. Fan motor checks were performed, and the GSE and airborne systems closed out for flight.

The entire CSM cryo loading operation was normal except that liquid hydrogen tank no. 1 was loaded to 98.7 percent instead of the desired minimum 99 percent (reason for this is still under study by both the Manned Spacecraft Center and the Kennedy Space Center) and a slight leak developed through the liquid oxygen tank no. 2 vent quick disconnect. The leak was stopped by the installation of the flight cap prior to tank pressurization. These conditions were determined to be acceptable for flight.

Spacecraft Closeout and Terminal Count

Following completion of the cryo loading operation the countdown proceeded normally from T - 32:00:00 through such milestones as: LM crew provision stowage and final closeout; LM SHe servicing; launch vehicle battery installation and electrical systems checks; CSM crew provision stowage; backup astronaut crew checks; and ALSEP fuel cask installation.

At 7:00 p.m. e.s.t. on April 10, 1970, the countdown clock was held at T - 9:00:00 for a planned built-in hold of 9 hours and 13 minutes. Following resumption of the countdown at 4:13 a.m. e.s.t. on April 11, 1970, final launch vehicle cryogenic loading preparations were completed and launch vehicle cryogenic loading was successfully conducted through 9:30 a.m. e.s.t.

The remainder of the countdown activities, including flightcrew ingress, final CSM cabin closeout, and the space vehicle terminal count, progressed normally with the exception of a minor problem with a broken key in the CSM pyro guard, and a stuck open no. 2 liquid oxygen vent valve in the S-IC stage. Both problems were satisfactorily resolved within the planned countdown time, which included a final built-in hold of 1 hour at T - 3:30:00 minutes.

LAUNCH AND TRANSLUNAR COAST PHASE PRIOR TO THE ACCIDENT

Launch and Flight Summary

The space vehicle was launched at 2:13:00 e.s.t., April 11, 1970. The only unexpected occurrence during the boost phase was an early shutdown of the S-II inboard engine. Low frequency oscillations (approximately 16 hertz) occurred on the S-II stage, resulting in a 132-second premature center engine cutoff. Preliminary analysis indicates that an engine pressure sensor detected a varying engine thrust chamber pressure resulting from a large pressure oscillation in the liquid oxygen system and turned the engine off. The four remaining engines burned approximately 34 seconds longer than normal, and the S-IVB orbital insertion burn was approximately 9 seconds longer to achieve the required velocity. The cause of the liquid oxygen system oscillation is presently being studied by the Marshall Space Flight Center. A parking orbit with an apogee of 100.2 nautical miles and a perigee of 98.0 nautical miles was obtained.

After orbital insertion, all launch vehicle and spacecraft systems were verified and preparations were made for translunar injection. The second S-IVB burn was initiated on schedule for translunar injection.

All major systems operated satisfactorily and conditions were nominal for a free-return circumlunar trajectory. With the spacecraft in a free-return trajectory, and with no further major propulsion burns, the spacecraft would pass around the Moon and reenter the Earth's atmosphere.

The command service module (CSM) separated from the service module LM adapter (SLA) at 3:06:39. The spacecraft was maneuvered and docked with the lunar module (LM) at 3:19:09 and the LM separated from the SLA at 04:01:00. The S-IVB was then maneuvered using residual propellants to impact the lunar surface. The first midcourse correction (23.1 fps), performed at 30:40:50 using the service propulsion system, inserted the spacecraft into a non-free-return trajectory with a pericyinthian altitude close to the planned value of about 60 miles. Under these conditions, with no further propulsion engine burns, the spacecraft would orbit the Earth in a highly elliptical orbit. These trajectories are discussed in more detail in Part B6 of this Appendix.

The mission was routine and generally proceeded according to the timeline. Because the crew was ahead of schedule and midcourse correction number 3 was cancelled, an early entry into the lunar module was made at 55:00:00. A scheduled television broadcast to the Earth was made between 55:15 and 55:46, and at the time of the accident,

both the Commander and Command Module Pilot were in the command module while the Lunar Module Pilot was just entering the command module from the lunar module.

Spacecraft Systems Operation

This section of the report will deal only with problems and events in the various systems encountered with the CSM during the powered phase, parking orbit, and translunar coast phase of the mission up to the time of the accident. The systems will be treated separately except that electrical current and voltage fluctuations associated with the operation of the fans to stir the supercritical oxygen and hydrogen will be covered under the cryogenic section.

CSM structural-mechanical.- Structural loads during boost phases of the flight were within acceptable limits. Command module structural oscillations of less than 0.1g at 16 hertz in all directions were measured during the period of S-II longitudinal oscillations (POGO) prior to the center engine cutoff. The levels of these oscillations were comparable to those measured during ground test and on previous Apollo missions.

At approximately 00:25:00 minutes, a computer program was entered into the computer to align the inertial measuring unit. During this alignment, the sextant is rotated, which in turn releases the external ablative optics covers. The optics covers are spring loaded, and held in place by clips. When the sextant is rotated, an arm located on the sextant engages a cam that releases the clips and jettisons both covers. Minor difficulty was experienced in jettisoning the two covers. The optics were rotated twice manually to 90 degrees according to the checklist, but the covers did not jettison. The optics were then rotated in the automatic mode (past 90 degrees) and the covers jettisoned. The cause of the covers not jettisoning was that the sextant was not rotated far enough in the manual mode to completely engage the cam.

After CSM/LM docking, the crew reported that two docking latches were not fully engaged. Both latches were opened and reset. There are 12 docking latches on the command module. Each latch has a trigger that is engaged when the lunar module docking ring comes in contact with the CSM docking ring. The handle has a red indicator that indicates when the latch is engaged. On several spacecraft during ground checkout one or two of the latches had to be reset manually, as in the case of Apollo 13. The prime cause is not having the two docking rings perfectly parallel at the time of engagement. The manual resetting of one or two of the latches is considered satisfactory.

The crew reported a slight "burnt" smell in the tunnel area between the CSM/LM when entering the tunnel, which is normal.

Electrical power.- The electrical power distribution and sequential system, except for the fuel cells, operated as expected until the time of the accident. The electrical parameters associated with the fan turnon and turnoff times will be discussed in Part B9.

At about 30:45:00 the fuel cell 3 condenser exit temperature pattern was observed to change to a sinusoidal ripple with a frequency of 1 cycle every 30 seconds and a peak-to-peak amplitude of 6.2° F. The oscillations continued for approximately 9 hours and then stopped. Similar oscillations had been observed on Apollo 10 during lunar orbit, and subsequent analyses and tests showed that the oscillations were not detrimental to the performance or life of the fuel cells. These transients are attributed to slugs of cold water leaving the condenser.

Instrumentation.- Four discrepancies in the instrumentation system were noted. At 46:40:06 the oxygen quantity measurement located in oxygen tank no. 2 indicated 100 percent. This anomaly will be discussed in detail in Part B9. The cabin pressure indicated 1/2 psi above the suit pressure until powerdown of the CSM after the incident. (Should be approximately the same with the crew out of the suits.) During the boost phase, when the cabin vented the transducer did not follow the cabin pressure and operated erratically for the remainder of the flight. This erratic operation was very similar to the erratic operation of the identical transducer on Apollo 12. Failure analysis of the Apollo 12 transducer indicated contamination inside the transducer.

Early in the mission (22:38 and 37:38) the potable water quantity transducer acted erratically for a brief period. This instrument has operated erratically on other spacecraft during ground checkout and flight due to oxidation of electrical winding on the transducer potentiometer. This oxidation causes intermittent contact between the wiper arm and the wiring on the potentiometer, thus giving erratic readings.

At approximately T + 32 hours, the crew reported that the spacecraft panel meters indicating fuel cell hydrogen versus oxygen flow were not exactly matched for fuel cell 3. All indications on the ground were normal. Prelaunch ground data once indicated a mismatch in panel indication on fuel cell 2. Since the instrumentation data in both cases were correct, the most probable cause was an intermittent fault in the meter circuitry causing the shift.

Communications.- At 55:05:32 the crew reported that they could not operate the high-gain antenna (HGA) in narrow beamwidth auto track or reacquisition modes. A maneuver to the passive thermal control (PTC) attitude was prescribed and as the maneuver was initiated, the crew manually positioned the antenna and acquired automatic tracking in the narrow beamwidth mode. The antenna operated normally until the accident. When troubleshooting (before lockup) both the primary and secondary electronics and both the automatic and reacquisition tracking modes were unsuccessfully attempted. Analysis indicates an effective misalignment existed between the boresight of the wide and narrow beams. The beam effective misalignment could have been caused by a defective radio frequency (RF) stripline coaxial cable, mechanical failure, or RF feed lines. A boresight shift was not indicated during antenna acceptance testing or during KSC ground checkout.

Service module propulsion and reaction control.- The service module propulsion system was used only once during the mission at 30:40:50 to place the spacecraft into a non-free-return trajectory. The engine burned for 3.6 seconds, and all parameters were nominal. The thrust chamber pressure seemed about 4 percent below preflight prediction, but within acceptable limits.

Guidance and control.- Guidance and control system performance was satisfactory, with the exception of small fluctuations of the optic shaft when in the zero optics mode and in establishing passive thermal control (PTC). At approximately 7:30:00 the crew reported difficulty in establishing PTC. The attempt resulted in a very wide and diverging coning angle. It was determined that the digital autopilot was incorrectly loaded and all roll thrusters were not enabled. The checklist did not call out the correct autopilot load and the thruster enabling was a late pen-and-ink change to the onboard checklist. Using the revised procedure, the PTC mode was successfully established.

At about 40:00 the ground controllers noticed small fluctuations of the optic shaft when in zero optics mode. As on Apollo 12, the ground data showed a slight jitter in the optics shaft angle from 0 to 0.6 degree. A special test was conducted at 49 hours to verify the shaft oscillations. The crew compared the shaft and trunnion angles to the mechanical counters on the optics. The oscillation was evident from both sources and occurred in the optics zero mode only. The optics jitter presented no constraint to the operation of the optical system; however, at 49:51:37 the ground requested the crew to turn off optics power to guard against possible degradation of the system.

Environmental control.- No anomalies were noted in the environmental control system operation.

Thermal control.- The thermal control system of the CSM performed normally until the incident.

Cryogenic system.- Both the liquid hydrogen and the liquid oxygen systems operated satisfactorily up to the time of the accident as far as the fuel cells and environmental control systems were concerned. Because of the unbalance in hydrogen quantities during loading, and unequal usage during launch pad operation, several hydrogen low-pressure master alarms were detected on the caution and warning system. (A description of the caution and warning system is contained in Appendix A, Part A2.10.) At 46:40:08 the oxygen tank no. 2 quantity measurement indicated 100 percent quantity and remained at this value until the pressure rise at 55:53:35. With the exception of the above, system operations were normal to the time of the accident.

The following sections will describe the low hydrogen pressure master alarm and supercritical liquid hydrogen and oxygen destratification up to the time of the accident.

Hydrogen Low Pressure Master Alarm

The caution and warning system, upon receipt of a malfunction or out-of-tolerance signal, simultaneously identifies the abnormal condition and alerts the crew to its existence. Each signal (both oxygen and hydrogen pressure are on one indicator) will activate the system status indicator, light the master alarm light, and place an audio tone in the crew's headsets. The crew can turn off or reset the master alarm; however, the particular system status malfunction indicators remain lit, blocking further master alarms on this indication, until the malfunction is cleared.

At lift-off, the quantity readings for the hydrogen tanks no. 1 and no. 2 were 91 percent and 93.4 percent, respectively. This was due to initial loading values (98.7 percent for tank no. 1 and 99.4 percent for tank no. 2) and the difference in usage during countdown.

At approximately 32:00 g.e.t., a quantity unbalance of 2.38 percent existed between the hydrogen tanks, and a quantity balancing procedure was conducted to prevent tank no. 1 low-pressure master alarms during the sleep period. In the "auto" mode the tank heaters are turned on and off by pressure switches connected in series. When the pressure in either tank reaches about 260 psi, the heaters in both tanks are switched off. The heaters remain off until the opened pressure switch closes at

approximately 225 psi. Since one tank pressure switch normally remains closed, the tank that controls the upper pressure will also control at the lower pressure. During the flight, tank no. 2 was controlling. Tank no. 1 pressure was almost reaching the caution and warning low pressure point (224.2 psia) prior to tank no. 2 reaching its pressure switch activation point of 233.6 psia to turn on the heaters.

Since tank no. 2 had the greater quantity, at 32:00 the tank no. 1 heaters were manually turned off by the crew while tank no. 2 remained in auto. This condition would allow the fuel cells to obtain hydrogen from tank no. 2 because of its higher pressure and in turn reduce its quantity of hydrogen. Several master alarms occurred immediately after this change (33:10, 33:41, 34:01, and 34:32).

At 36:48 the hydrogen tank no. 1 heater was placed back to auto for the sleep period. On the first "down" pressure cycle a master alarm occurred (38:00) due to hydrogen tank no. 1 pressure dropping lower than 224.24 psia, awaking the crew. The crew reset the alarm, and no master alarms occurred through the sleep period although the heaters cycled several times. To obtain a balanced condition for the next sleep period, the ground controllers devised the following plan for the next day's operation:

1. After crew wakeup, turn hydrogen tank no. 2 heater to off and leave hydrogen tank no. 1 in auto for two to three pressure cycles to determine if this will transfer heater control to tank no. 1 in anticipation of using this configuration for sleep.

2. If successful, tank no. 1 heaters will be turned off during the day and tank no. 2 heaters left in auto to create a quantity unbalance in favor of tank no. 1.

3. During the next sleep period, the tanks will be balanced by placing tank no. 1 heaters in auto and tank no. 2 heaters to off.

This plan was executed when the crew awoke the next day. At the time of the accident, tank no. 1 was in off and tank no. 2 was in auto, and the caution and warning master alarm was reset with a low hydrogen pressure indication present at 55:52:30. This hydrogen low pressure indication locked out the master alarm during the time of the increasing pressure in oxygen tank no. 2.

Cryogenic Tank Destratification

To prevent stratification in the oxygen and hydrogen tanks, two fans are located in each tank. A diagram of the oxygen tank showing

the two fans and quantity gaging probe is shown in figure B4-11. The flight plan called for the fans to be operated in both the hydrogen and oxygen tanks at the following times: 3:40, 12:09, 23:12, 29:40, 37:30, and 46:39 g.e.t. The ground controllers requested the oxygen tank no. 2 fans to be operated at 47:54 and both the oxygen and hydrogen fans be operated at 51:07.

Review of cryogenic and electrical instrumentation data does not indicate that the fans were switched on at 3:40 and at 29:40. No changes in cryogenic pressures and quantities, and no indications of an increase in spacecraft current were noted. The operation of the fans during the other destratification periods were normal; however, three oxygen tank no. 2 differences were noted: (1) transients on pitch and yaw thrust vector control gimbal command parameters at fan turnon and turnoff, (2) quantity gaging probe malfunctioned just after or at the time the fans came on, and (3) ac main bus 2 indicated a 1.8-volt negative transient when the fans were turned on at 47:54.

The pitch and yaw thrust vector control gimbal command (TVC command) parameters are an excellent transient detector on ac main bus 2 when the stabilization and control system is turned off because of its sensitivity and high sampling rate (100 samples per second). The sensitivity of the system is determined by the position of the rate high/low switch and the attitude deadband maximum/minimum switch. The TVC command signals are not transmitted to the ground when the instrumentation system is in low bit rate mode.

The system was in the low sensitivity mode during two destratification periods. When oxygen tank no. 2 fans were turned on during tank destratification periods, a negative initial transient was detected and when the fans were turned off, a positive initial transient was detected on the TVC command parameters. These transients are readily detectable in the high sensitivity mode and barely detectable in the low sensitivity mode. Examination of the Apollo 11 records indicates that the system was in the high sensitivity mode once during the fan destratification periods and a similar transient occurred when the fans were turned on. The data indicate that the transients are normal for fan turnon and turnoff, and only indicate a relatively large current change on ac main bus 2.

At 47:40:08 the oxygen quantity changed from approximately 82 percent to 100 percent, or full-scale high. This change in reading or quantity system malfunction occurred just after or at the time the oxygen tank no. 2 fans were turned on. Because of the way the system recovered at the time of the accident, the data indicate that the probe or its associated wiring shorted. Since the instrumentation system was in low bit rate, it is possible to determine exactly when the oxygen

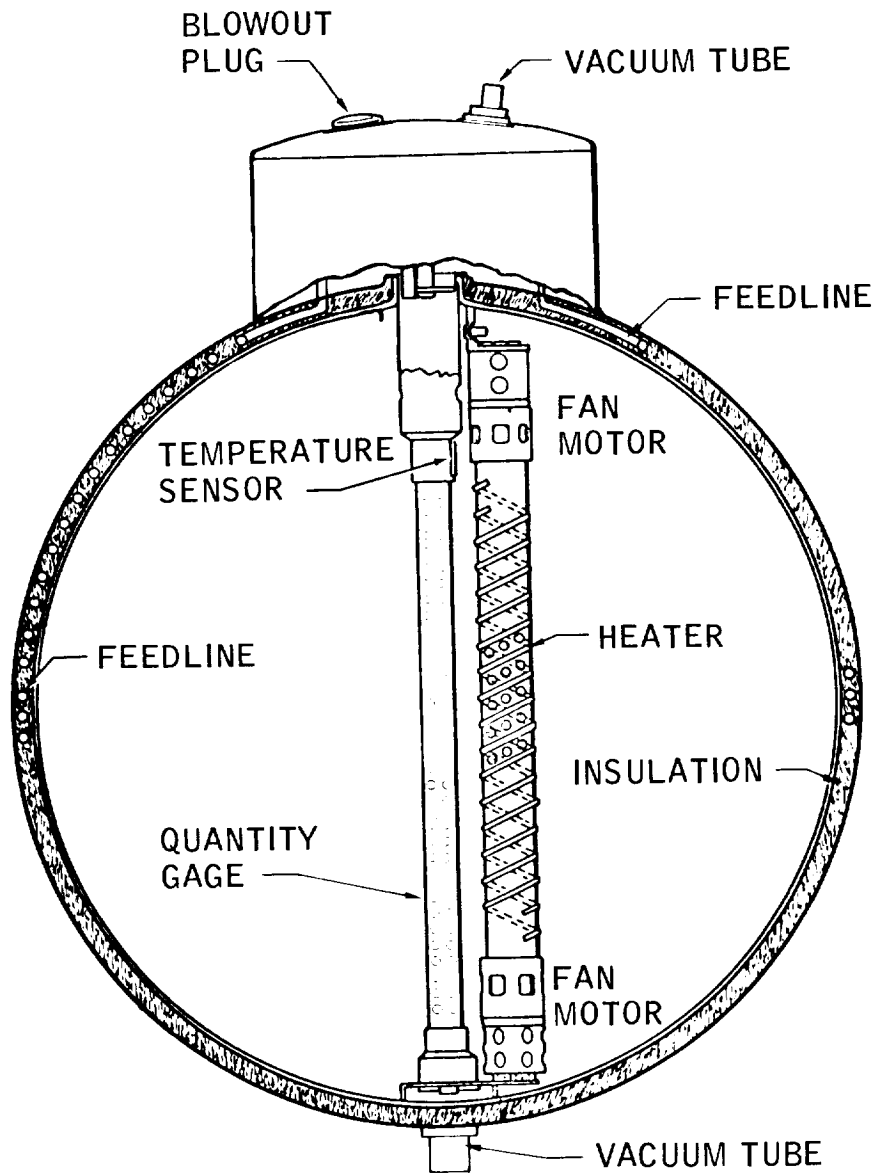

Figure B4-11.- Arrangement of components within oxygen tank.

tank no. 1 and no. 2 fans were turned on. The electrical data indicate that the oxygen tank no. 1 and no. 2 fans were turned on between the times of 47:40:05 and 47:40:08. A plot of cryogenic pressures, quantities, total CSM current, and ac main bus 2 is shown in figure B4-12. Therefore, the oxygen tank no. 1 and no. 2 fans were turned on in a period of time between 3 seconds prior to the probe malfunction and the time that the probe malfunctioned.

When the oxygen tank no. 2 fans were turned on the next time at 47:54:50, the ac main bus 2 decreased 1.8 volts for one sample (0.1 second). At the same time the TVC command parameters indicated a negative initial transient. Because of the sampling rate (10 samples per second) of the instrumentation system and the small number of fan cycles examined in the high bit rate mode, it cannot be determined if this negative initial transient is characteristic of other fan turnon's or is an indication of a deteriorating fan or wiring.

The complete oxygen and hydrogen tank destratification history prior to the accident is shown in table B4-I. Changes in oxygen and hydrogen pressures and quantities indicate normal destratification of the tanks during all fan cycles. The next destratification period occurred at 55:53:18, or when the events started leading to the accident.

References 1 through 6 and instrumentation records were used as a source of information and data in the preparation of this part of the report.

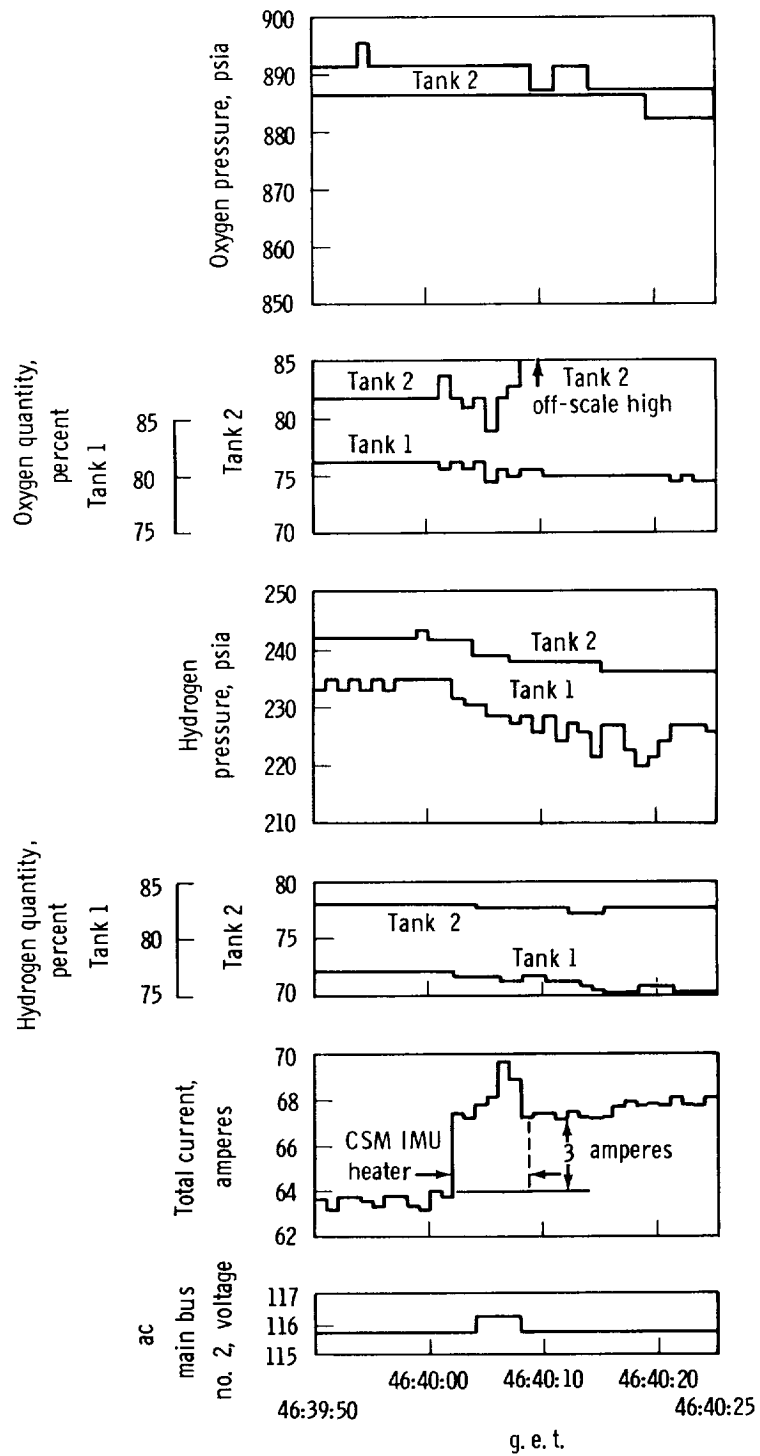

Figure B4-12.- Fan cycle at 46:40.

TABLE B4-I.- CRYOGENIC TANK DESTRATIFICATION

Planned destratification	Actual start of destratification	Verified air-to-ground	SCS transients	Remarks
3:40:00	No indications	Not verified	No indications	No indications
12:09:00 Presleep checklist	12:08:58 to 12:09:04	Not verified	12:09:03.6	Normal destratification
23:12:00 Postsleep checklist	23:10:53 to 23:11:01.5	Verified	23:11:01	Normal destratification
29:40:00	No indications	Not verified	Low bit rate	No indications
37:30:00 Presleep checklist	36:46:19 to 36:46:21	Partial verification	36:46:20.5	Normal destratification
46:39:00 Postsleep checklist	46:40:02 to 46:40:05-08	Verified	Low bit rate	Normal destratification quantity gaging system malfunctioned
Ground control request (0 tank no. 2 only)	47:54:50	Verified	47:54:50	Normal destratification - fans ran for approximately 11.5 minutes
Ground control request	51:07:43 to 51:07:47	Verified	Low bit rate	Normal destratification

PART B5

INCIDENT EVENTS

INTRODUCTION

This part of the report covers the significant events which took place at the time of the accident. The period covered is 55:52:00 g.e.t. to 56:00:05 g.e.t. Prior to this period, spacecraft operation had been essentially according to plan and neither the ground controllers nor the crew had any warning of the events about to occur. The first indication of a problem was a loud bang heard by all three crew members which was followed by a master caution and warning. The immediate indications in the spacecraft were that this warning had been triggered by an electrical transient. Several minutes later two fuel cells failed in the power system, and the crew became fully occupied trying to reconfigure the spacecraft electrical system. Fourteen minutes later they noticed venting and began to understand what had actually happened in the cryogenic oxygen system.

On the ground, the flight controllers first noticed that the spacecraft computer had been automatically restarted. Shortly afterwards, indication of a master caution and warning caused the flight controllers to scan their data for a problem. Since many telemetry measurements had by this time departed from their nominal values, the ground controllers' immediate reaction was to suspect an instrumentation failure. Steps were undertaken to sort the false telemetry readings from the true ones; and, simultaneously, instructions were given to help the crew handle new problems. About an hour later the ground personnel had sorted out the facts sufficiently to know that it would only be a short time before the cryogenic oxygen system would fail completely.

Reconstruction of the mission events in the detail presented in the following pages has required several hundred man-days of data analysis. Consequently, the crew and mission controllers could not possibly have understood the situation in the same depth at the time the events were actually happening. The primary sources of data for the analysis have been telemetry records, transcripts of voice communications, crew debriefings, and interviews with personnel on duty in Mission Control.

Table B5-I is a detailed chronology of the events during this time period, and figure B5-1 shows the sequence of events grouped according to spacecraft systems. For events obtained from telemetry data, where time is shown to a fraction of a second, this refers to the time at which the parameter in question was actually sampled by the telemetry system. As discussed in Part B7 of this Appendix, the characteristics of the

telemetry system place an uncertainty on the time of an event. The uncertainty is a function of the telemetry system sampling rate.

The remainder of this section is a discussion of the events at the time of the accident, grouped according to the spacecraft systems involved.

TABLE B5-I.- DETAILED CHRONOLOGY FROM
2.5 MINUTES BEFORE THE ACCIDENT TO 5 MINUTES AFTER THE ACCIDENT

<u>Time, g.e.t.</u>	<u>Event</u>
Events During 52 Seconds Prior to First Observed Abnormality	
55:52:31	Master caution and warning triggered by low hydrogen pressure in tank no. 1. Alarm is turned off after 4 seconds.
55:52:58	Ground requests tank stir.
55:53:06	Crew acknowledges tank stir.
55:53:18	Oxygen tank no. 1 fans on.
55:53:19	Oxygen tank no. 1 pressure decreases 8 psi.
55:53:20	Oxygen tank no. 2 fans turned on.
55:53:20	Stabilization control system electrical disturbance indicates a power transient.
55:53:21	Oxygen tank no. 2 pressure decreases 4 psi.
Abnormal Events During 90 Seconds Preceding the Accident	
55:53:22.718	Stabilization control system electrical disturbance indicates a power transient.
55:53:22.757	1.2-volt decrease in ac bus 2 voltage.
55:53:22.772	11.1-amp rise in fuel cell 3 current for one sample.
55:53:36	Oxygen tank no. 2 pressure begins rise lasting for 24 seconds.
55:53:38.057	11-volt decrease in ac bus 2 voltage for one sample.
55:53:38.085	Stabilization control system electrical disturbance indicates a power transient.

TABLE B5-I.- DETAILED CHRONOLOGY FROM
2.5 MINUTES BEFORE THE ACCIDENT TO 5 MINUTES AFTER THE ACCIDENT - Continued

<u>Time, g.e.t.</u>	<u>Event</u>
55:53:41.172	22.9-amp rise in fuel cell 3 current for one sample.
55:53:41.192	Stabilization control system electrical disturbance indicates a power transient.
55:54:00	Oxygen tank no. 2 pressure rise ends at a pressure of 953.8 psia.
55:54:15	Oxygen tank no. 2 pressure begins to rise.
55:54:30	Oxygen tank no. 2 quantity drops from full scale for 2 seconds and then reads 75.3 percent.
55:54:31	Oxygen tank no. 2 temperature begins to rise rapidly.
55:54:43	Flow rate of oxygen to all three fuel cells begins to decrease.
55:54:45	Oxygen tank no. 2 pressure reaches maximum value of 1008.3 psia.
55:54:48	Oxygen tank no. 2 temperature rises 40° F for one sample.
55:54:51	Oxygen tank no. 2 quantity jumps to off-scale high and then begins to drop until the time of telemetry loss.
55:54:52	Oxygen tank no. 2 temperature reads -151.3° F.
55:54:52.703	Oxygen tank no. 2 temperature suddenly goes off-scale low.
55:54:52.763	Last telemetered pressure from oxygen tank no. 2 before telemetry loss is 995.7 psia.
55:54:53.182	Sudden accelerometer activity on X, Y, and Z axes.
55:54:53.220	Stabilization control system body rate changes begin.

TABLE B5-I.- DETAILED CHRONOLOGY FROM
 2.5 MINUTES BEFORE THE ACCIDENT TO 5 MINUTES AFTER THE ACCIDENT - Continued

<u>Time, g.e.t.</u>	<u>Event</u>
55:54:53.323	Oxygen tank no. 1 pressure drops 4.2 psi.
55:54:53.5	2.8-amp rise in total fuel cell current.
55:54:53.542	X, Y, and Z accelerations in CM indicate 1.17g, 0.65g and 0.65g, respectively.
1.8-Second Data Loss	
55:54:53.555	Loss of telemetry begins.
55:54:53.555+	Master caution and warning triggered by dc main bus B undervoltage. Alarm is turned off in 6 seconds. All indications are that the cryogenic oxygen tank no. 2 lost pressure in this time period and the panel separated.
55:54:54.741	Nitrogen pressure in fuel cell 1 is off-scale low indicating failed sensor.
55:54:55.35	Recovery of telemetry data.

Events During 5 Minutes Following the Accident

55:54:56	Service propulsion system engine valve body temperature begins a rise of 1.65° F in 7 seconds.
55:54:56	Dc main bus A decreases 0.9 volt to 28.5 volts and dc main bus B decreases 0.9 volt to 29.0 volts.
55:54:56	Total fuel cell current is 15 amps higher than the final value before telemetry loss. High current continues for 19 seconds.
55:54:56	Oxygen tank no. 2 temperature reads off-scale high after telemetry recovery.
55:54:56	Oxygen tank no. 2 pressure reads off-scale low following telemetry recovery.

TABLE B5-I.- DETAILED CHRONOLOGY FROM
2.5 MINUTES BEFORE THE ACCIDENT TO 5 MINUTES AFTER THE ACCIDENT - Continued

<u>Time, g.e.t.</u>	<u>Event</u>
55:54:56	Oxygen tank no. 1 pressure reads 781.9 psia and begins to drop steadily.
55:54:57	Oxygen tank no. 2 quantity reads off-scale high following telemetry recovery.
55:54:59	The reaction control system helium tank C temperature begins a 1.66° F increase in 36 seconds.
55:55:01	Oxygen flow rates to fuel cells 1 and 3 level off after steadily decreasing.
55:55:02	The surface temperature of the service module oxidizer tank in bay 3 begins a 3.8° F increase in a 15-second period.
55:55:02	The service propulsion system helium tank temperature begins a 3.8° F increase in a 32-second period.
55:55:09	Dc main bus A voltage recovers to 29.0 volts; dc main bus B recovers to 28.8 volts.
55:55:20	Crew reports, "I believe we've had a problem here."
55:55:35	Crew reports, "We've had a main B bus undervolt."
55:55:49	Oxygen tank no. 2 temperature begins steady drop lasting 59 seconds.
55:56:10	Crew reports, "Okay right now, Houston. The voltage is looking good, and we had a pretty large bang associated with the caution and warning there. And as I recall, main B was the one that had had an amp spike on it once before."
55:56:38	Oxygen tank no. 2 quantity becomes erratic for 69 seconds before assuming an off-scale-low state.

TABLE B5-I.- DETAILED CHRONOLOGY FROM
2.5 MINUTES BEFORE THE ACCIDENT TO 5 MINUTES AFTER THE ACCIDENT - Concluded

<u>Time, g.e.t.</u>	<u>Event</u>
55:57:04	Crew reports, "That jolt must have rocked the sensor on--see now--oxygen quantity 2. It was oscillating down around 20 to 60 percent. Now it's full-scale high again."
55:57:39	Master caution and warning triggered by dc main bus B undervoltage. Alarm is turned off in 6 seconds.
55:57:40	Dc main bus B drops below 26.25 volts and continues to fall rapidly.
55:57:44	Ac bus 2 fails within 2 seconds.
55:57:45	Fuel cell 3 fails.
55:57:59	Fuel cell 1 current begins to decrease.
55:58:02	Master caution and warning caused by ac bus 2 being reset. Alarm is turned off after 2 seconds.
55:58:06	Master caution and warning triggered by dc main bus A undervoltage. Alarm is turned off in 13 seconds.
55:58:07	Dc main bus A drops below 26.25 volts and in the next few seconds levels off at 25.5 volts.
55:58:07	Crew reports, "ac 2 is showing zip."
55:58:25	Crew reports, "Yes, we got a main bus A undervolt now, too, showing. It's reading about 25-1/2. Main B is reading zip right now."
56:00:06	Master caution and warning triggered by high hydrogen flow rate to fuel cell 2. Alarm is turned off in 2 seconds.

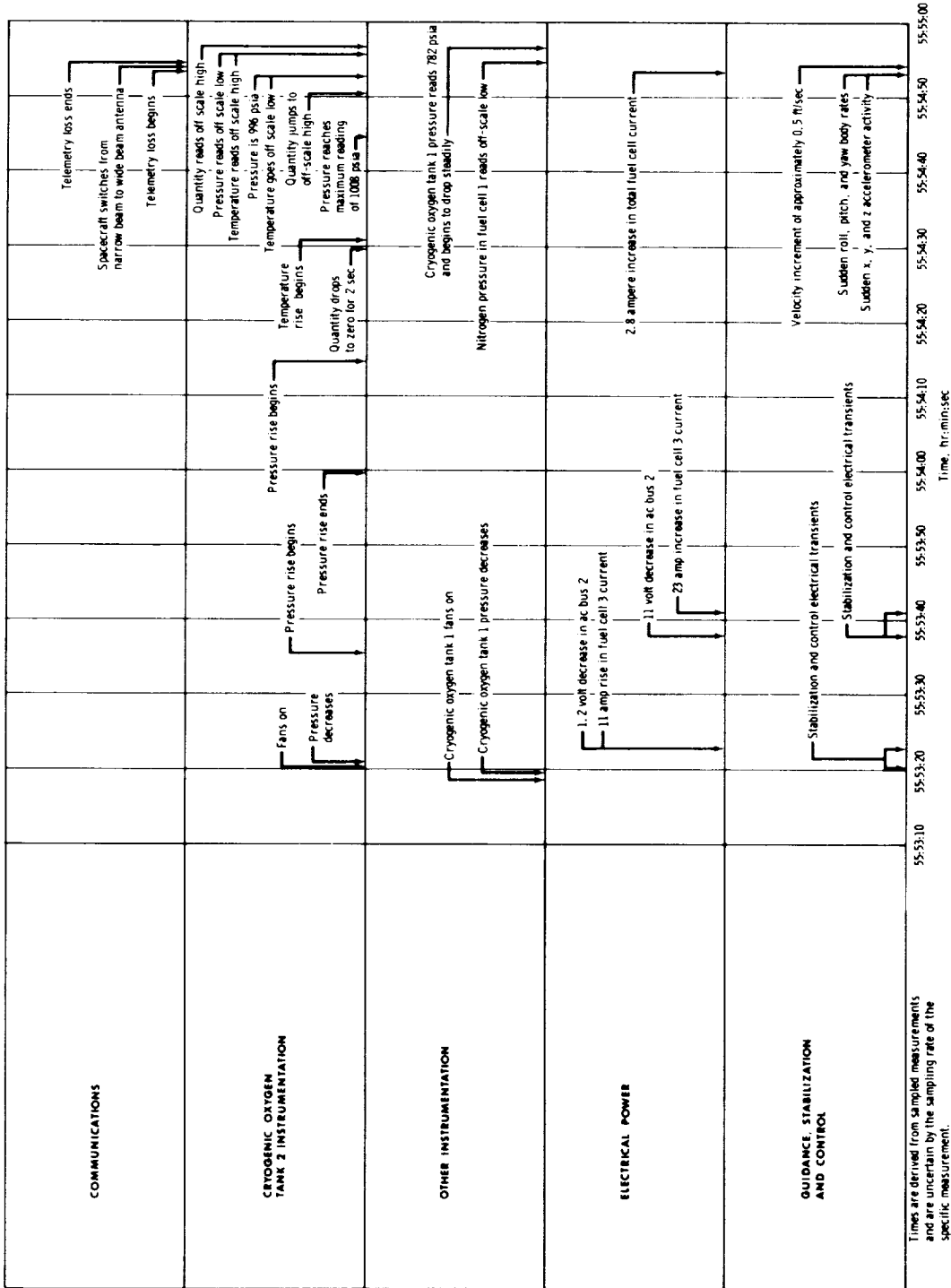

Figure B5-1.- Sequence of events immediately preceding the accident.

STATUS OF THE SPACECRAFT PRIOR TO THE ACCIDENT

At 55:52:00, just prior to the accident, the electrical system was configured as shown in figure B5-2. Fuel cells 1 and 2 were supplying main bus A; fuel cell 3 was supplying main bus B. The power for the fans in cryogenic oxygen tank no. 2 was being supplied by ac bus 2, as was power for the quantity sensor in that tank. The stabilization control system thruster vector control system was receiving its power from ac bus 2. Two quantities in this system, the pitch and yaw thrust vector control gimbal commands, though not intended for measurement of electrical system currents and voltages, are sensitive indicators of electrical transients on ac bus 2. These quantities are telemetered to the ground with a sampling rate of 100 samples per second. At 55:52:00 the telemetry system was operating in the high-bit-rate mode and the narrow beam antenna was in use.

The cryogenic oxygen tank no. 2 quantity gage had failed to a 100-percent reading in the 46th hour of the flight. (See Part B4, the subsection entitled "Spacecraft Systems Operation.") All other cryogenic oxygen instrumentation was operating normally.

The cryogenic hydrogen tank 1 pressure decreased sufficiently to trigger the master caution and warning at 55:52:31. (For a description of the master caution and warning system, see Part 2.10 of Appendix A.) The ground then requested a fan cycle, and the crew acknowledged the request. A fan cycle consists of the crew turning on the stirring fans located in both the cryogenic oxygen and hydrogen tanks and allowing them to run for approximately 1 minute. Normally, the hydrogen fans are turned on first, followed by the fans in oxygen tank no. 1 and a few seconds later by the fans in oxygen tank no. 2.

FAN TURNON AND ASSOCIATED ELECTRICAL ANOMALIES

At 55:53:18 when the two fans in cryogenic oxygen tank no. 1 were turned on by the crew, a drop in ac bus 1 voltage (fig. B5-3) and an increase of 1 ampere in total command module current indicated that the fans had been electrically energized. (Total command module current, plotted in figure B5-4, is obtained by adding the current outputs of all three fuel cells and subtracting the current drain of the lunar module.) A subsequent decrease in tank pressure and oscillations in the fuel cell flowmeters indicated that the fans had begun to stir the oxygen (fig. B5-3).

At 55:53:20 the crew turned on the cryogenic oxygen tank no. 2 fans. An increase in fuel cell current of 1-1/2 amperes, a drop in ac bus 2

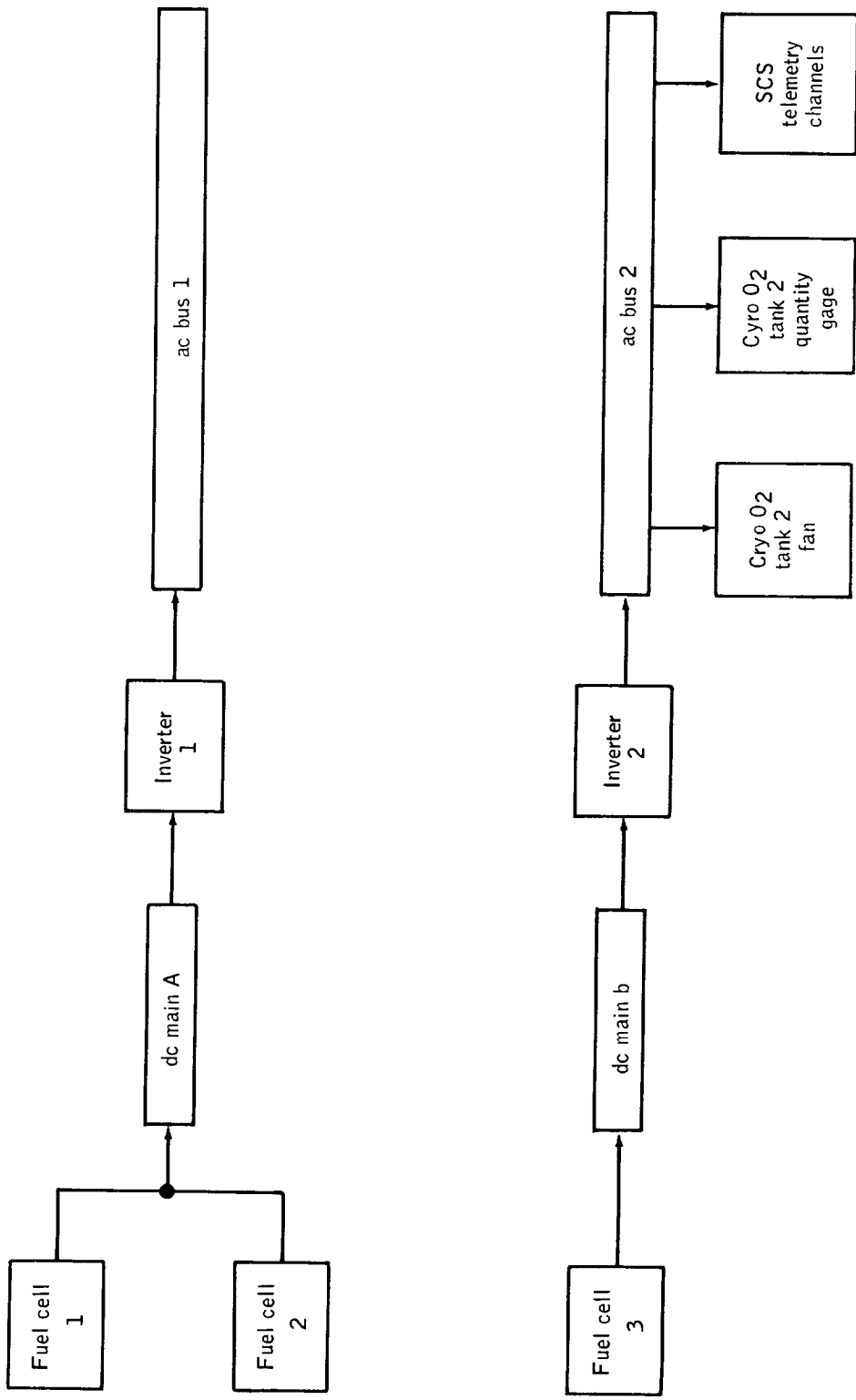

Figure B5-2.- Configuration of electrical power system at 55:53:20.

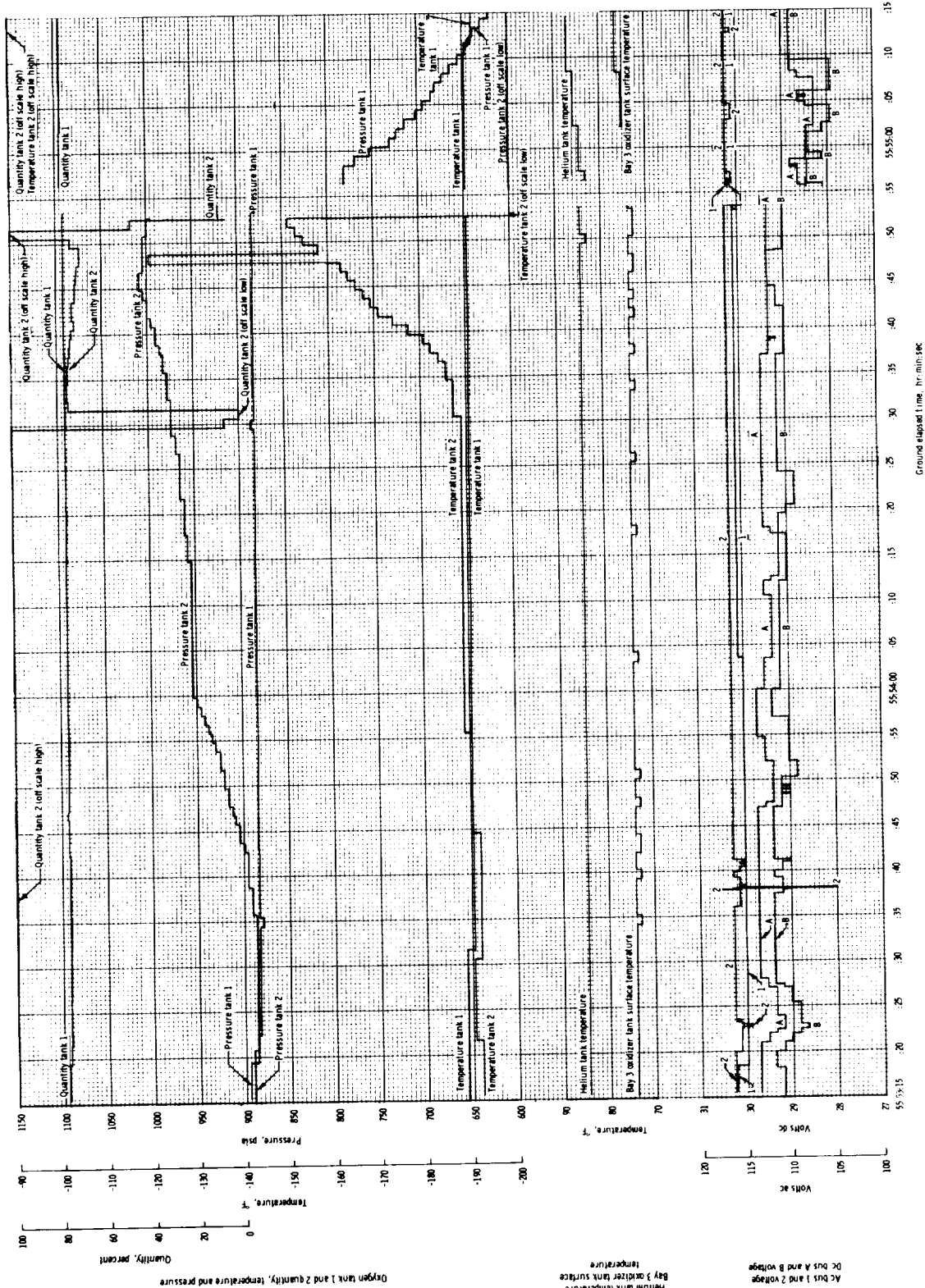

Figure B5-3(a).-- Telemetered parameters during anomaly.

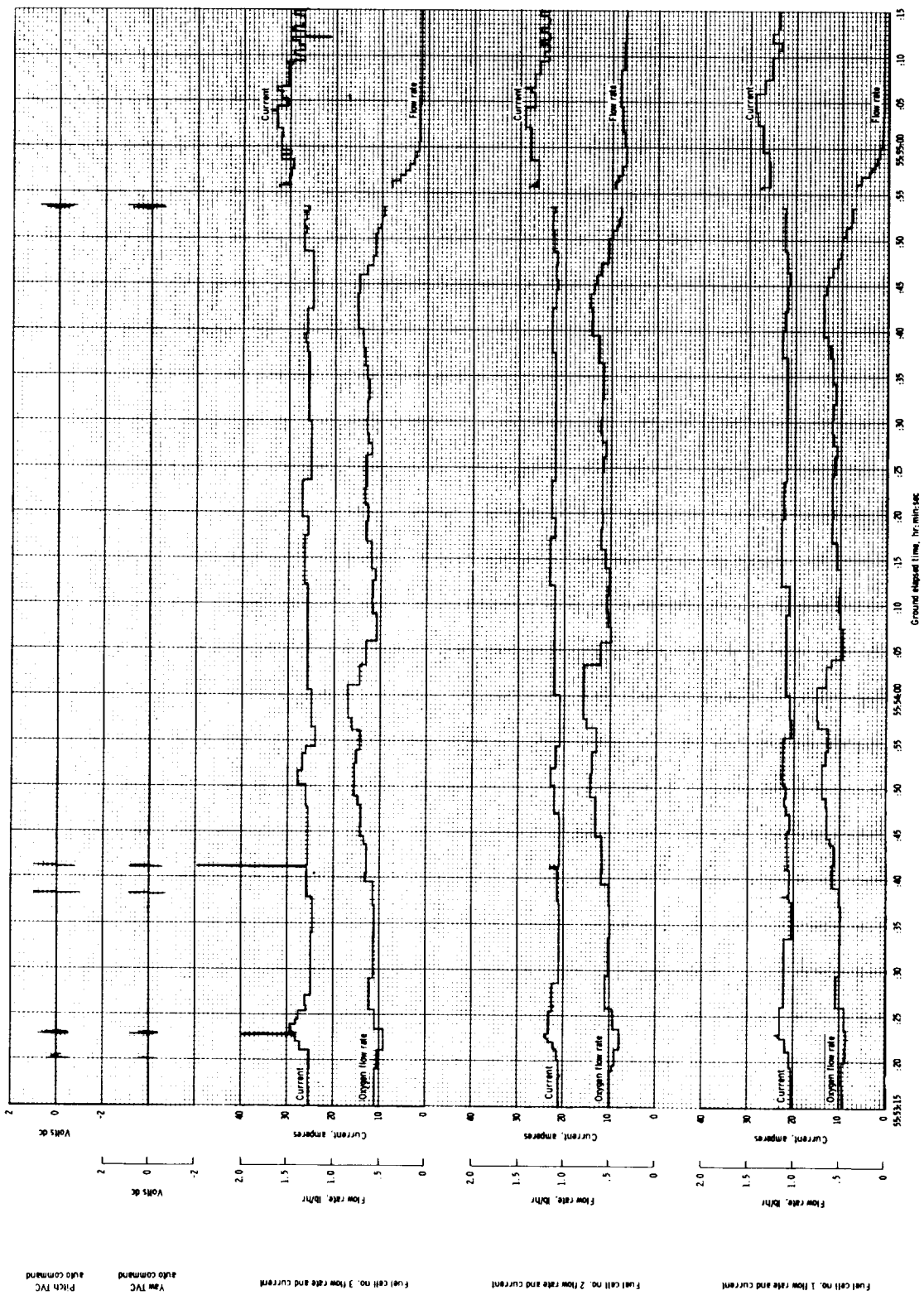

Figure B5-3(b).- Telemetered parameters, concluded.

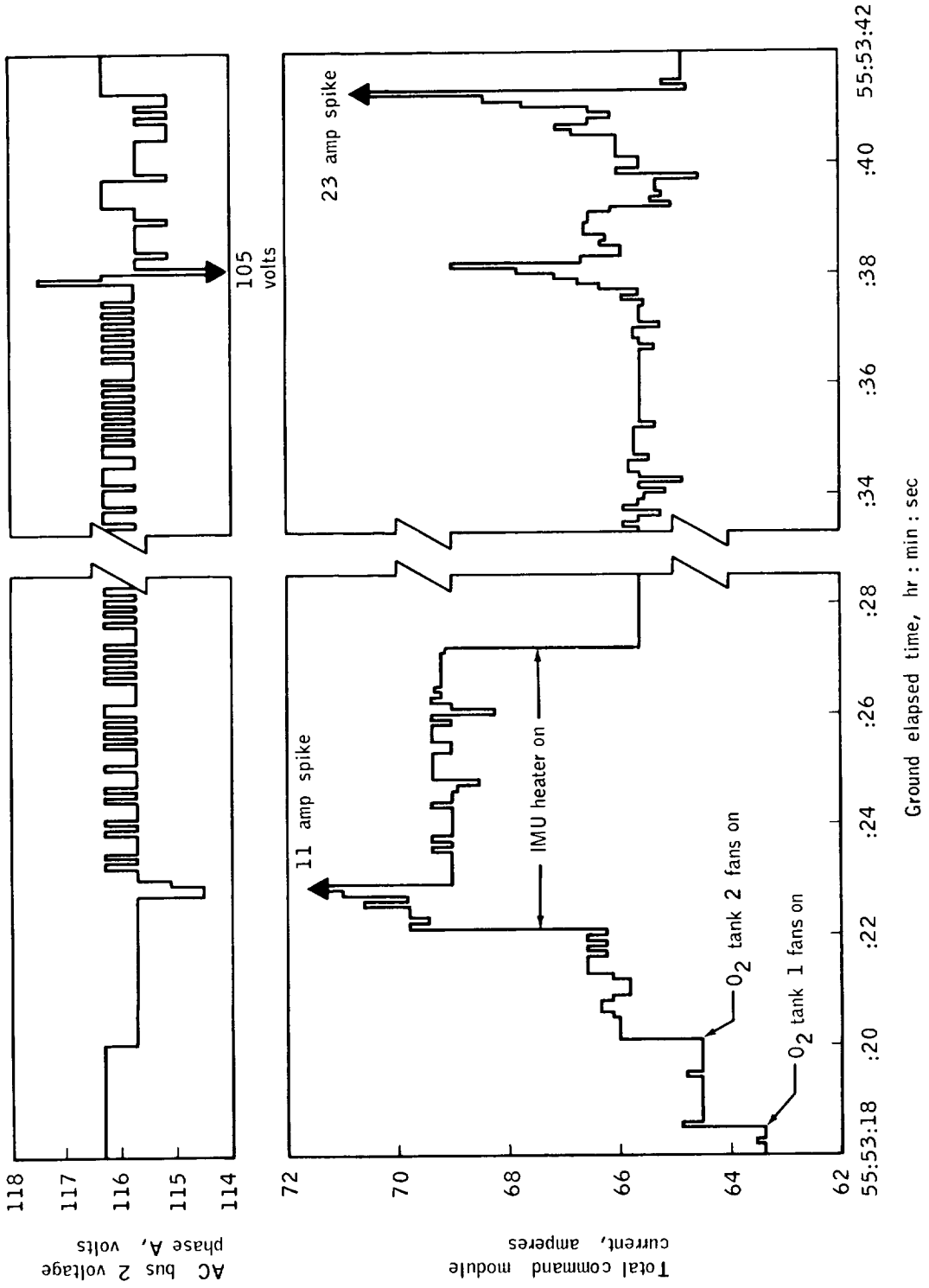

Figure B5-4.- Electrical anomalies.

voltage of 0.6 volt, and a glitch in the stabilization control system telemetry indicated that the fans had been electrically energized. These events are shown in figures B5-4 and B5-5. However, it is not certain that the fans began rotating at this time, since the tank no. 2 pressure showed a minimum observable drop and the fan motor stall current does not significantly differ from the running current. The quantity gage in tank no. 2 was already in a failed condition, and the fuel cell flowmeters were already being affected by the fan operation in tank no. 1. so that neither of these instruments could positively verify rotation of the fans in tank no. 2. During the next 20 seconds a series of electrical anomalies occurred which cannot be explained as a result of known loads in the spacecraft. These anomalies are shown in figure B5-4. The first, at 55:53:23 was an 11-amp positive spike in the output current of fuel cell 3. Several events were associated with this spike:

(a) The command module current decreased approximately 1/2 ampere immediately afterward.

(b) The ac bus 2 voltage had a transient decrease and then began to alternate between 115.7 and 116.3 volts, whereas it had been maintaining a steady value of 115.7 volts since fan turnon.

These events indicate that at the time of the 11-amp spike, a load may have been disconnected from ac bus 2. This could have been one of the fan motors in cryogenic oxygen tank no. 2.

At 55:53:38 another abnormal electrical disturbance occurred, a 3-amp spike of current and variations in ac bus 2 voltage. The ac bus 2 voltage first increased 2 volts and then dropped suddenly from 116 to 105 volts. The ac bus 2 is a three-phase electrical system, although the only voltage telemetered is phase A. The operation of the inverter which generates ac bus 2 is such that it attempts to maintain a constant average voltage among the three phases; if one phase becomes heavily loaded, the inverter will increase the voltages of the other two phases. Consequently, it is possible that the voltage rise in ac bus 2 at 55:53:37.8 was caused by a heavy load applied to phase B or phase C. The decrease in voltage immediately afterward was probably caused by loading of phase A.

At 55:53:41 a 23-amp spike occurred on fuel cell 3 output current, after which the total command module current returned to a steady value within 0.3 ampere of the value prior to turnon of cryogenic oxygen tank no. 2 fans. Also, the voltage of ac bus 2 returned to the value it had shown prior to fan turnon. At the same time transients appeared in the stabilization control system, as shown in figure B5-5.

The most probable cause of the electrical disturbances between 55:53:22 and 55:53:42 is that a short circuit occurred in the electrical

system of the cryogenic oxygen tank no. 2 fans. The short circuit was sufficiently severe to result in loss of part of the fan load at 55:53:22 and the remainder at 55:53:41. Reduction of the load could have been caused by fuses blowing or by wires opening.

It should be noted that the nature of the telemetry records makes it difficult to define the exact parameters of the electrical disturbances. Since the value of fuel cell 3 current is sampled by the telemetry system at 10 times per second, the duration of the observed current spikes is in question by 0.2 second. Also, the peak values of the spikes may well have exceeded the maximum recorded values. For similar reasons a large current spike could possibly have occurred at 55:53:38 simultaneous with the 11-volt decrease of ac bus 2. If the spike were very short, less than 0.1 second duration, it could have occurred between the times of successive telemetry samples and thus not have been recorded.

The electrical anomalies ended by 55:53:42 and no further electrical disturbances were observed for the next minute.

OXYGEN TANK PARAMETERS FROM 55:53:30 UNTIL LOSS OF TELEMETRY

Thirteen seconds after the 11-amp spike and 6 seconds before the 23-amp spike, the pressure in cryogenic oxygen tank no. 2 began a steady increase at an abnormally rapid rate. The increase began at 55:53:35 and lasted 19 seconds before the pressure reached a plateau of 954 psia for 21 seconds. At 55:54:15 the pressure rise resumed, reaching a maximum value of 1008 psia 9 seconds before loss of telemetry. During this rise the master caution and warning trip level of 975 psia was exceeded, but a master alarm was not generated because of the existing cryogenic pressure warning occasioned by low hydrogen pressure. After reaching 1008 psia, the pressure decreased to 996 psia just before loss of telemetry. The oxygen flow rate for all three fuel cells declined for about 10 seconds and then began to rise just before loss of telemetry.

The pressure transducer for cryogenic oxygen tank no. 2 is not located in the tank but is connected to the tank along with a pressure relief valve through 19 feet of tubing. The relief valve is set to open fully at 1008 psia. (See figure B7-4 for a diagram of this portion of the cryogenic oxygen system and Part B7 of this Appendix for a more complete description of the cryogenic oxygen pressure sensing system). The remote location of the oxygen pressure transducer causes some time lag in the telemetered pressure data but unless there are unknown restrictions, such as clogging of the filter at the tank end of the line, this lag will not cause serious errors in the pressure reading under the conditions observed.

This page left blank intentionally.

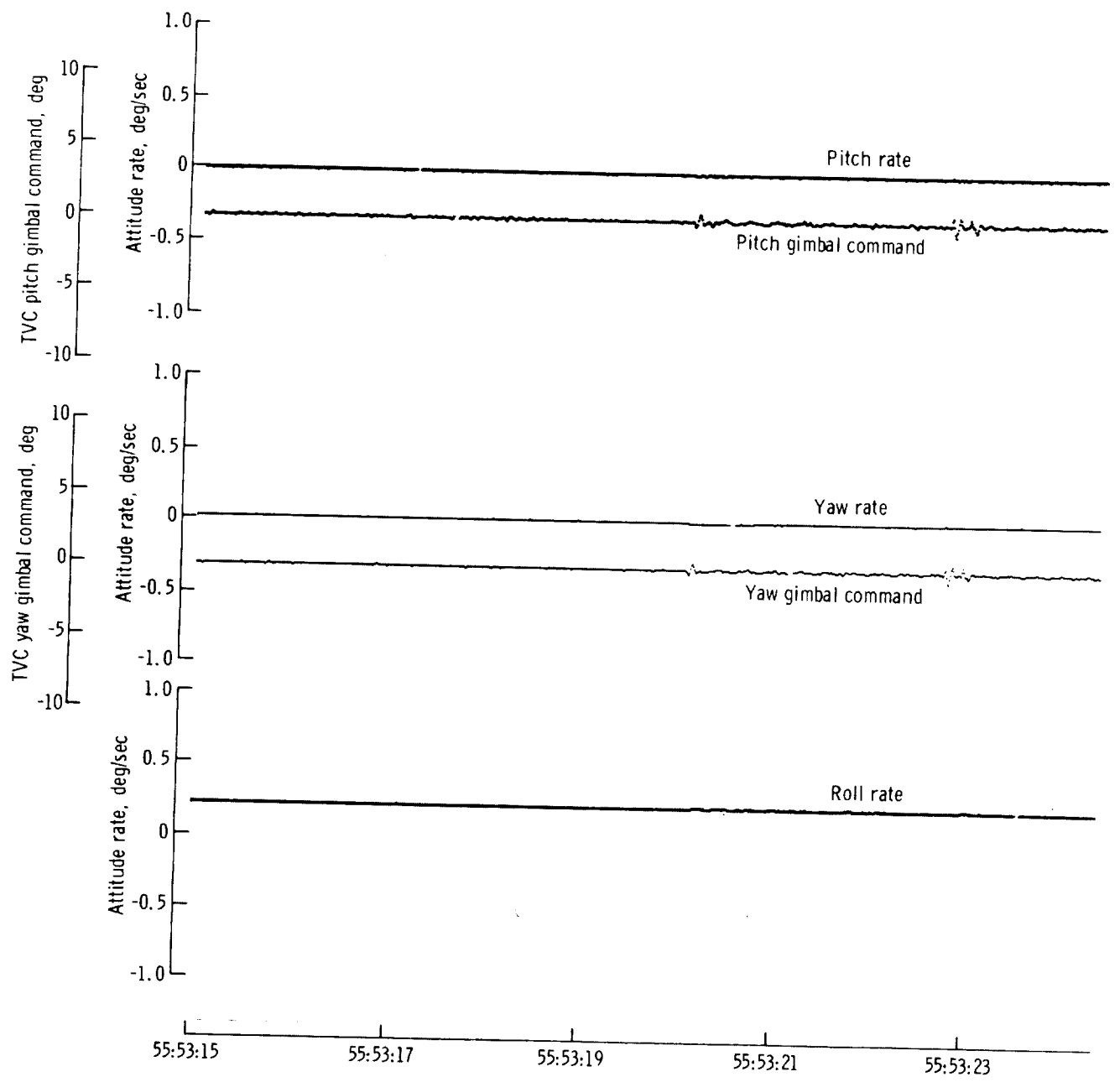

The quantity gage for oxygen tank no. 2, which had been in a failed state ever since the 46th hour, suddenly dropped to 6.6 percent and then to off-scale low at 55:54:30. These readings do not correlate with other telemetered data and are, consequently, thought to be erroneous. The gage then jumped to a 75-percent reading, which may be reliable data since it is about the value to be expected. Afterwards the quantity decreased gradually for 19 seconds until 3 seconds before telemetry loss, at which time an erratic gage output occurred. The behavior of this type of gage when a short across the capacitor probe is removed is to drop to zero for several seconds and then return to a correct reading. However, the gage has other failure modes which result in a wandering false indication. See Part B7 of this Appendix for a discussion of the quantity gage. Because of the gage's erratic behavior, it cannot be stated with complete confidence that the 75-percent reading obtained at 55:54:32 is reliable.

The temperature in cryogenic oxygen tank no. 2 remained at -190° F $\pm 2^{\circ}$ until 55:54:31 when a steady rise in temperature commenced. At 55:54:48 a single data sample indicated a reading 40 degrees higher than the adjacent readings. The last data sample before loss of telemetry was off-scale low, probably indicating a short circuit in the gage or wiring. As discussed in Part B7 of this Appendix, the time constant of the temperature sensor is in the order of at least tens of seconds, which means that the 40-degree jump in reading at 55:54:48 and the final off-scale reading were both due to sensor failure or telemetry system errors. Also, because of the slow gage response, the indicated rate at which the temperature rose between 55:54:31 and 55:54:52 could have been caused by an actual temperature rise of greater magnitude.

The temperature and quantity of cryogenic oxygen tank no. 1 remained steady until telemetry loss. The pressure remained nominal until 0.2 second prior to telemetry loss, when a slight drop was observed.

LOSS OF TELEMETRY

At the time of the accident the spacecraft telemetry signal was being received on both a 210-ft-diameter and an 85-ft-diameter antenna at the Deep Space Instrumentation Facility in Goldstone, California. The carrier level on the Goldstone 85-ft antenna was -100 dBm. At 55:54:53 the signal strength dropped abruptly below -160 dBm, the lower limit of the signal strength recorder, and began an erratic increase. Figure B5-6 is a plot of the carrier strength received at the 85-ft antenna, corrected by 8 dB to show the carrier strength received at the 210-ft antenna. The 210-ft antenna was not equipped with a signal strength recorder.

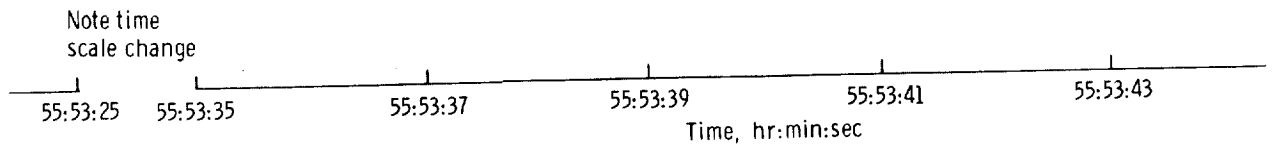
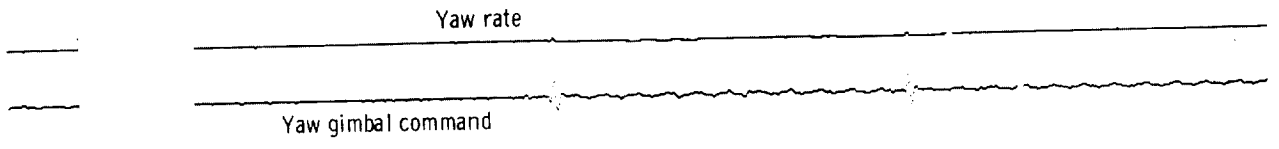
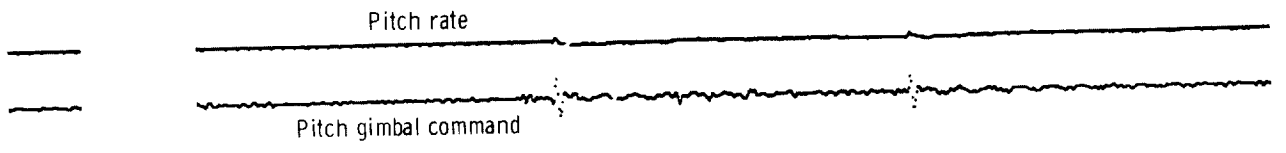

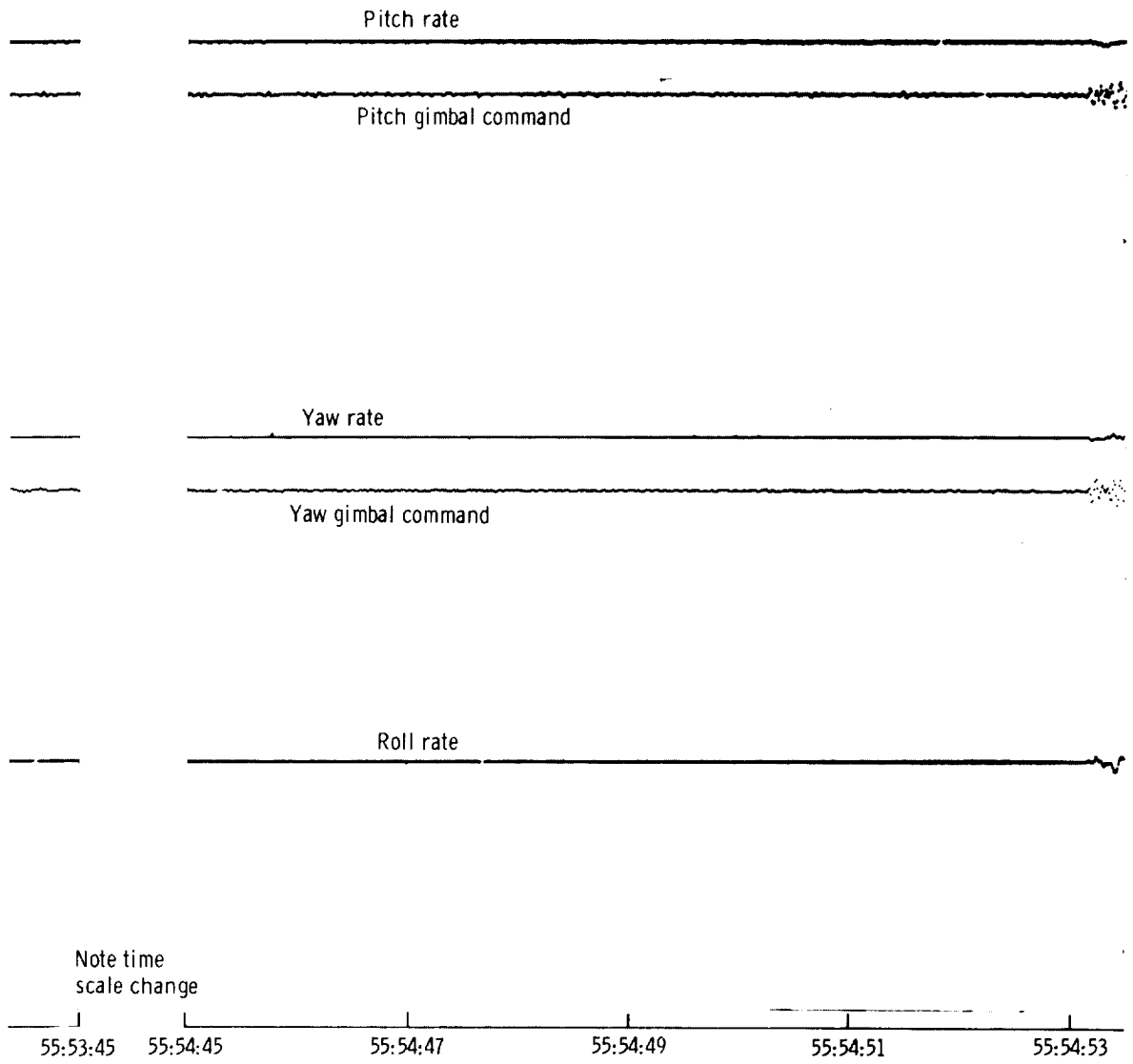

Figure B5-5.- Disturbances observed on thrust vector control gimbal command signals.



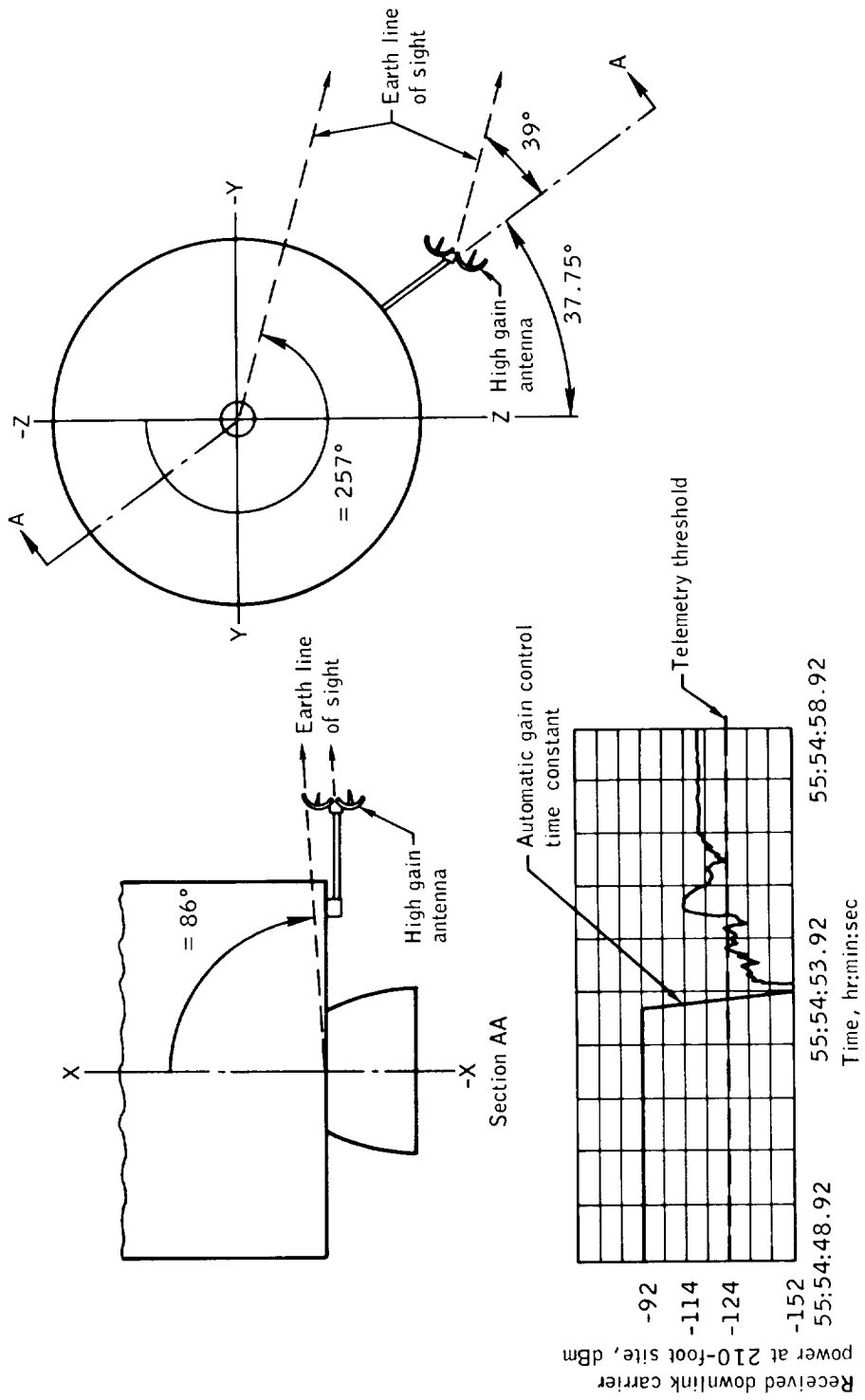

Figure B5-6.- Received S-band downlink power.

Telemetry data recovered completely 1.8 seconds after the loss of carrier power. Sporadic telemetry data are available within the 1.8-second period.

The recorded input signal to the PCM bit detector provides an indication of the rapidity with which the telemetry signal was lost. There appears to be some degradation in signal-to-noise ratio in the time period from 55:54:53.51 to 55:54:53.555. This may have been the result of attitude changes of the spacecraft causing mispointing of the high-gain antenna. At 55:54:53:555 an abrupt change in the character of the signal occurred, and the signal-to-noise ratio rapidly decreased in a period of 1 millisecond. The limitations in the available records make it impossible to definitely determine the speed with which the loss occurred, but an estimate is 1 millisecond.

Although figure B5-6 indicates that the signal required 0.3 second to decrease 60 dB, the actual time was probably much shorter. The decrease of 60 dB in 0.3 second is the same as that obtained when the input signal is abruptly removed from the receiver. This slow response is caused by long time constant circuitry in the automatic gain control.

When the telemetry signal was reacquired, the spacecraft had switched from the narrow-beam antenna to the wide-beam antenna. This has been verified by signal-strength calculations and comparisons of antenna patterns with spacecraft attitude. The spacecraft is designed to automatically switch to the wide-beam antenna if the pointing error of the narrow-beam antenna exceeds 3 degrees.

If a power supply interruption larger than 0.4 second occurs in the communication system, the system design is such that the power output will automatically drop 19 dB for a 90-second period. This power reduction cannot be observed in the received signal strength after recovery of telemetry.

SPACECRAFT EVENTS AT THE TIME OF TELEMETRY LOSS

A large number of spacecraft events took place approximately at the time of telemetry loss. These events are discussed in detail in the following sections as they relate to the various spacecraft systems. This section describes the events as an aid in understanding their interrelationship.

Within the last second prior to telemetry loss, several indications of spacecraft motion appeared on the telemetry records of body accelerometers, and roll, pitch, and yaw rate. The total fuel cell current increased by 3 amperes at the last data sample.

When telemetry data were restored at 55:54:55.35, a large number of channels associated with the electrical system, stabilization control system, and cryogenic system showed marked changes (fig. B5-3). Both dc main A and main B had dropped 0.9 volt and the master caution and warning had been triggered because of an undervoltage on main bus B. The undervoltage triggering level is 26.25 volts and the initial voltage on main B registered 28.1 volts. All three fuel cell currents had increased by 5 amperes over the values before telemetry loss. Both ac bus voltages had maintained their previous values. All telemetry readings from cryogenic oxygen tank no. 2 showed off-scale readings. The temperature was off-scale in the high temperature direction, the quantity gage read 100 percent, and the pressure gage read off-scale low. The capability of the gage is to read pressures as low as 19 psia. Cryogenic oxygen tank no. 1 had not changed temperature or quantity. However, the pressure had decreased from 879 psia to 782 psia. The regulated nitrogen pressure in fuel cell 1 dropped to zero during telemetry loss and remained at zero. The continued operation of this fuel cell indicates a sensor malfunction. As shown in figure B5-7, the wires from the nitrogen pressure sensor to the telemetry system pass along the front of the shelf which supports the fuel cells, in close proximity to the panel covering bay 4. It is quite possible that damage to these wires caused the change observed in the nitrogen pressure reading.

Approximately at the time of telemetry loss all three crew members heard a single loud bang. One or two seconds later they noted the master caution and warning caused by main bus B undervoltage and at 55:55:00 turned off the alarm. They also verified that fuel cell currents were normal at this time. Figure B5-8 is a photograph of the command module control panel showing the type of displays provided the crew. At 55:55:20 the crew reported, "I believe we've had a problem here," and at 55:55:35, "We've had a main B bus undervolt." Later they reported that a computer restart had occurred at the time of the bang, which had already been noted in Mission Control.

Photographs later taken by the crew show the panel covering bay 4, the bay containing the cryogenic oxygen tanks, cryogenic hydrogen tanks, and fuel cells, to be missing. One of these photographs is reproduced in figure B5-9 and a photograph prior to launch is shown in figure B5-10. The high-gain antenna located adjacent to bay 4 shows a misalignment of one of the four dishes. The photographs also show that the axes of fuel cells 1 and 3 have shifted 7 degrees in such a way that the tops of the fuel cells point outward. It is not possible to determine conclusively from the photographs whether or not cryogenic oxygen tank no. 2 is present, partially missing, or totally missing. It is probable that the loud bang heard by the crew was caused by the separation of the panel from the spacecraft approximately at the time of telemetry loss.

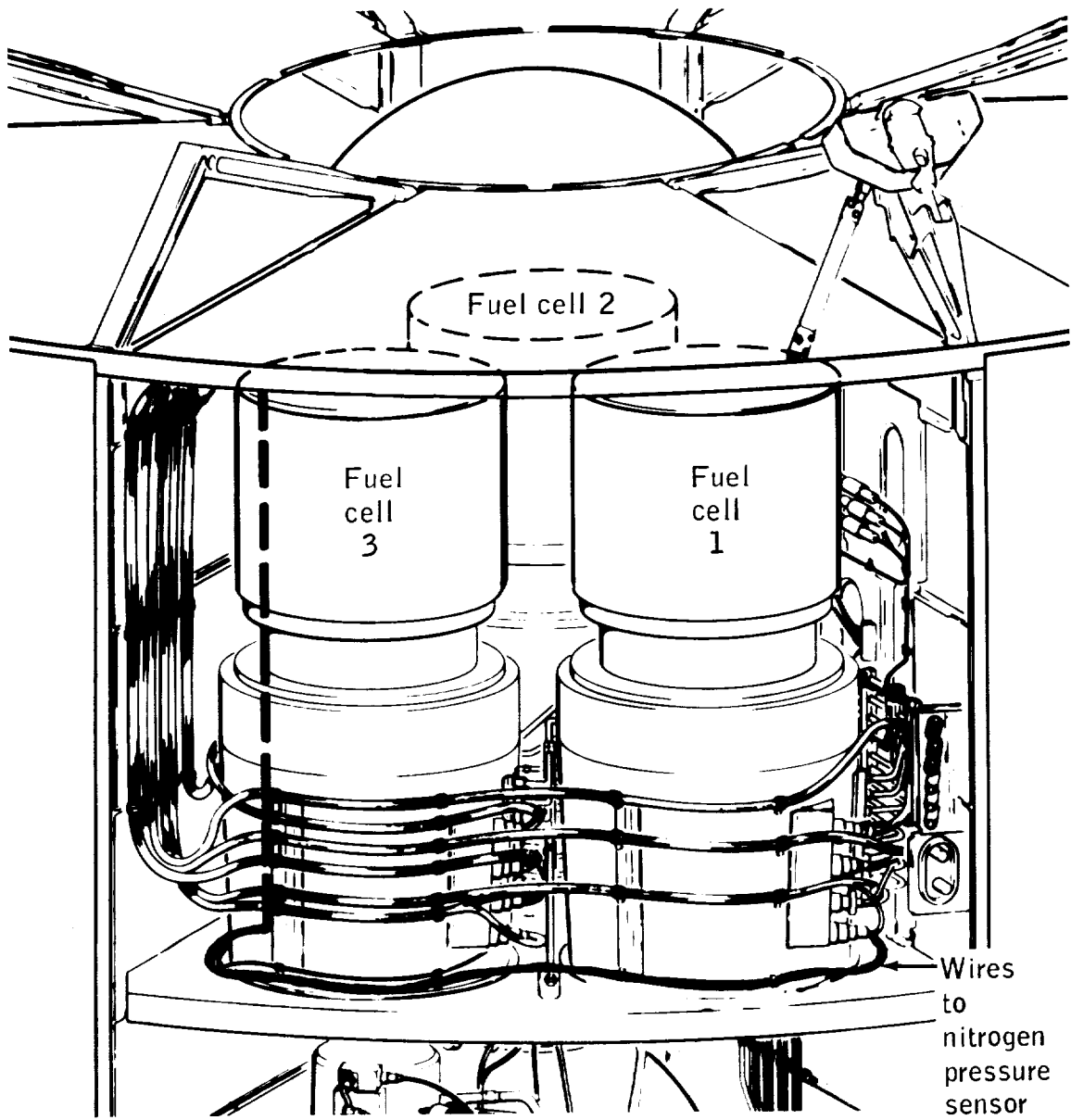

Figure B5-7.- Location of wiring to nitrogen pressure sensor in fuel cell 1.

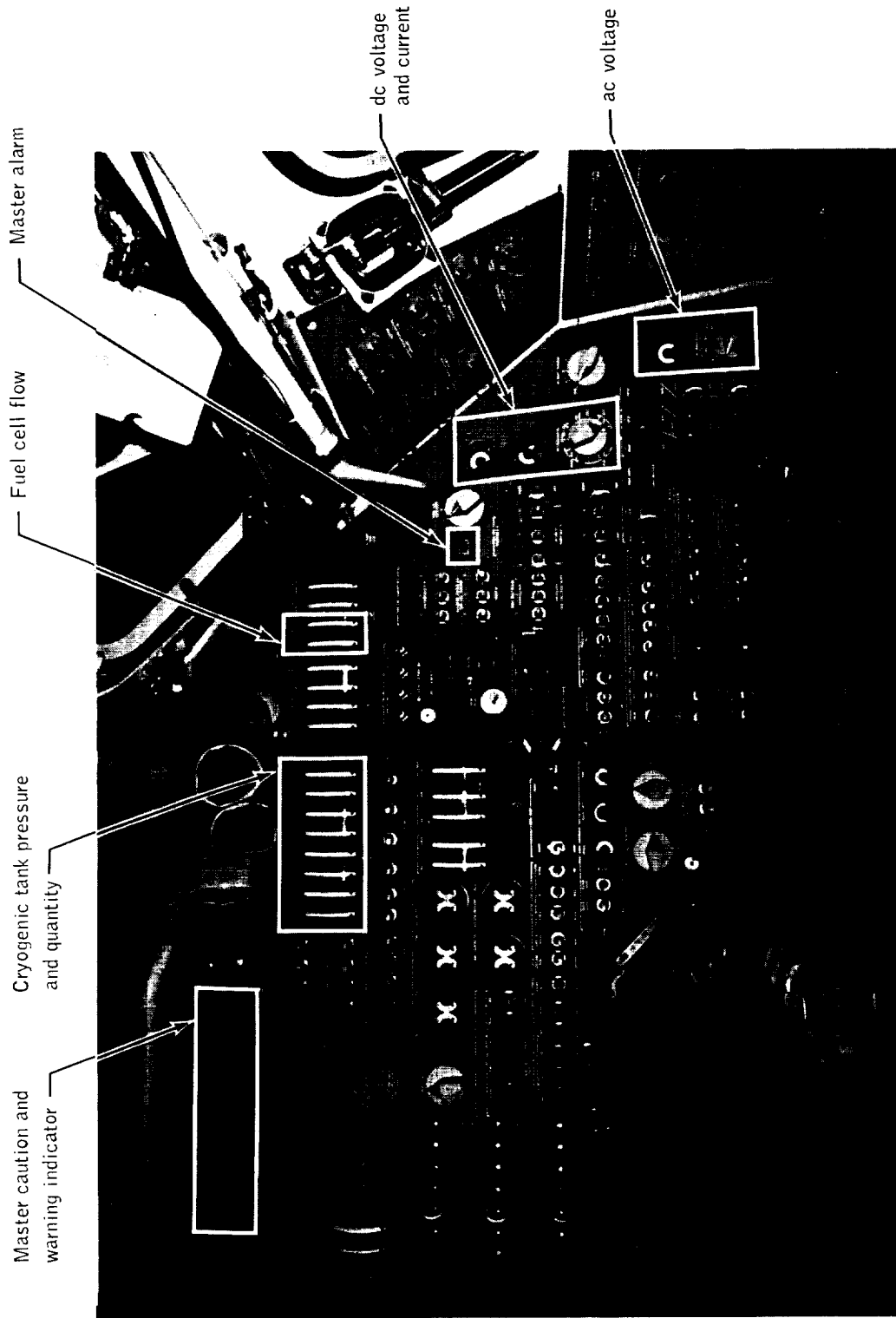

Figure B5-8.- Command module instrument panel.

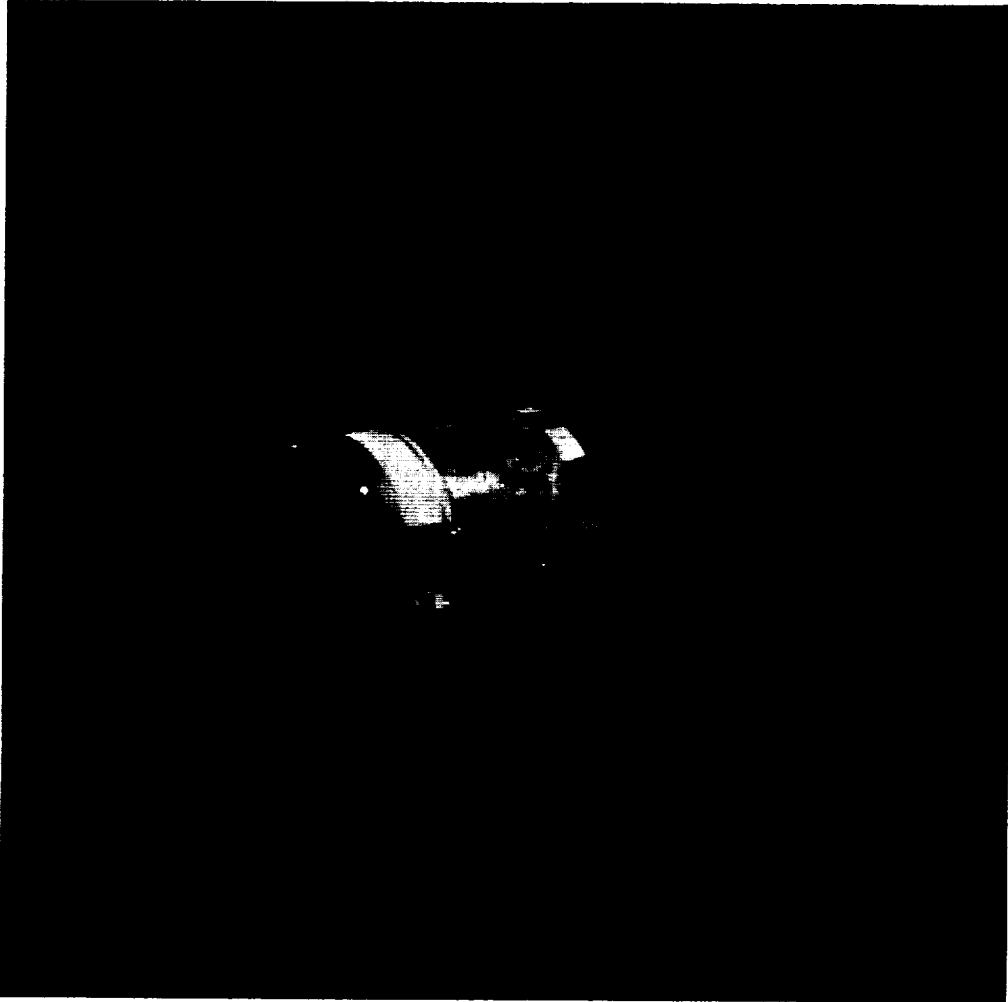

Figure B5-9.- Photograph of service module taken by crew.

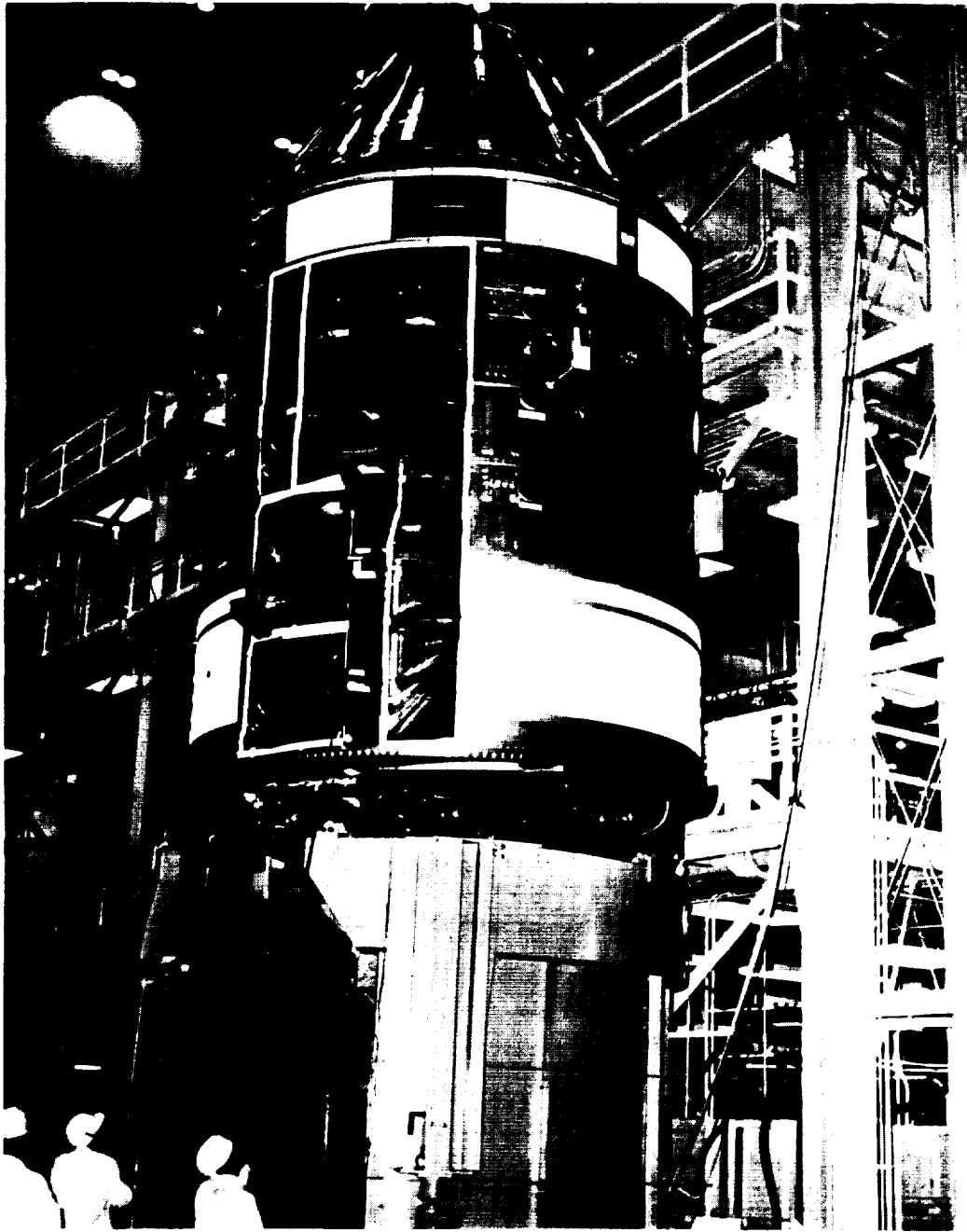

Figure B5-10.- Bay 4 of service module.

CHANGES IN SPACECRAFT DYNAMICS

At 55:54:53.182, less than half a second before telemetry loss, the body-mounted linear accelerometers in the command module, which are sampled at 100 times per second, began indicating spacecraft motions. These disturbances were erratic but reached peak values of 1.17g, 0.65g, and 0.65g in the X, Y, and Z directions, respectively, about 13 milliseconds before data loss.

At 55:54:53.220 the pitch, roll, and yaw rate gyros indicated low-amplitude variations in output. These gyros are body mounted in the command module, have a full-scale range of ± 1 degree per second, are sampled 100 times per second, and provide a fairly sensitive indication of spacecraft motions. They are also sensitive to electrical disturbances not necessarily associated with the gyros; however, the characteristics of the output at 55:54:53.220 are believed to have resulted from low-amplitude dynamic forces acting on the spacecraft. These channels were, of course, lost at 55:54:53.555, along with all other telemetered data. Figure B5-11 is a record of all three rate gyro outputs.

When telemetry was recovered at 55:54:55.35, these channels definitely indicated that moments had been applied to the spacecraft. The total change in angular moment was:

Roll	-1535 ft-lb-sec
Pitch	-6482 ft-lb-sec
Yaw	-5919 ft-lb-sec

The roll, pitch, and yaw rates were automatically compensated for by the attitude control system, as shown in figure B5-11.

The inertial platform on the command module contains three mutually orthogonal integrating accelerometers, whose outputs are telemetered with an increment value of 0.2 fps. After telemetry was recovered, a change of two increments was observed in one axis, one increment in the second axis, and zero increments in the third axis.

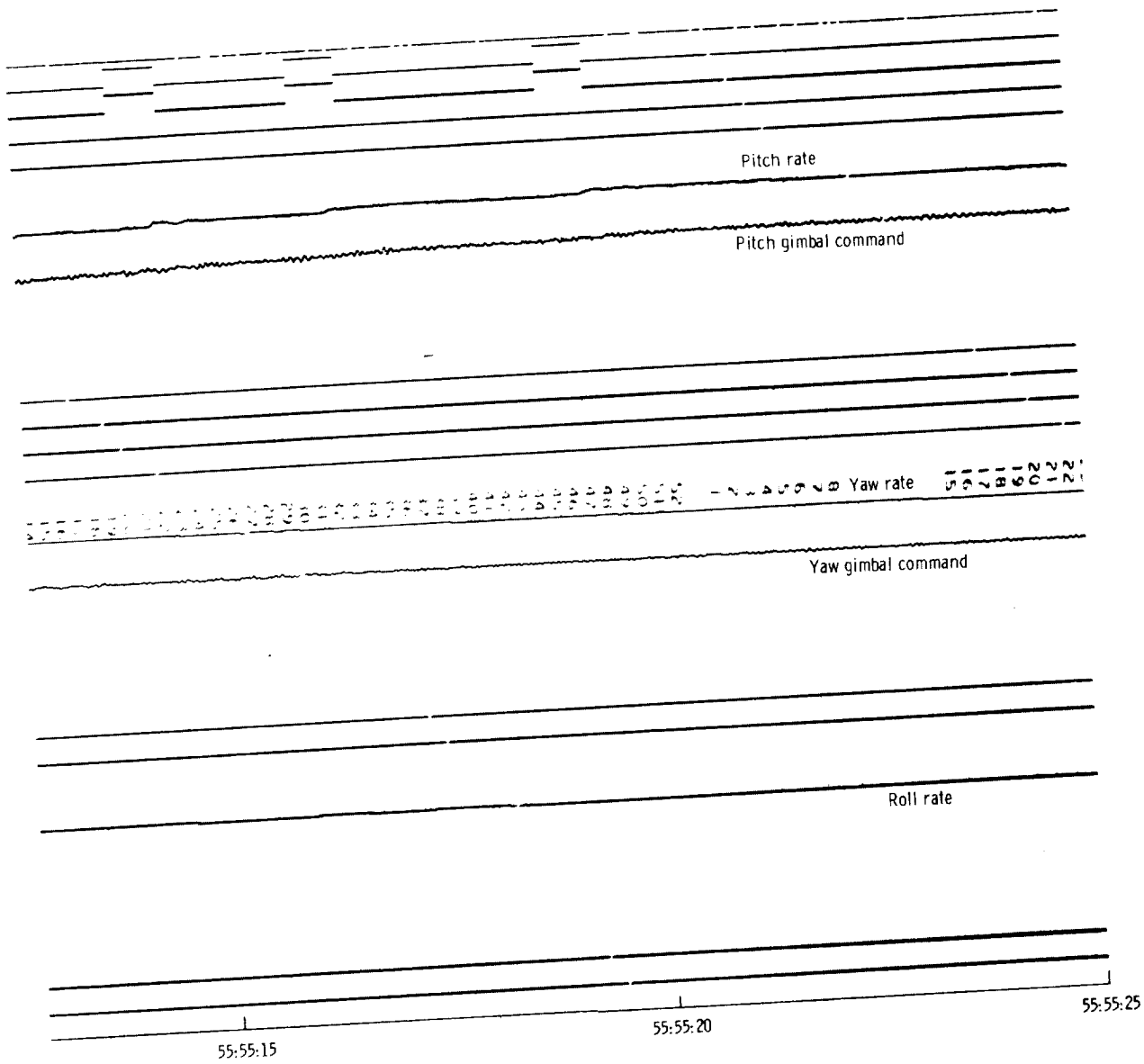
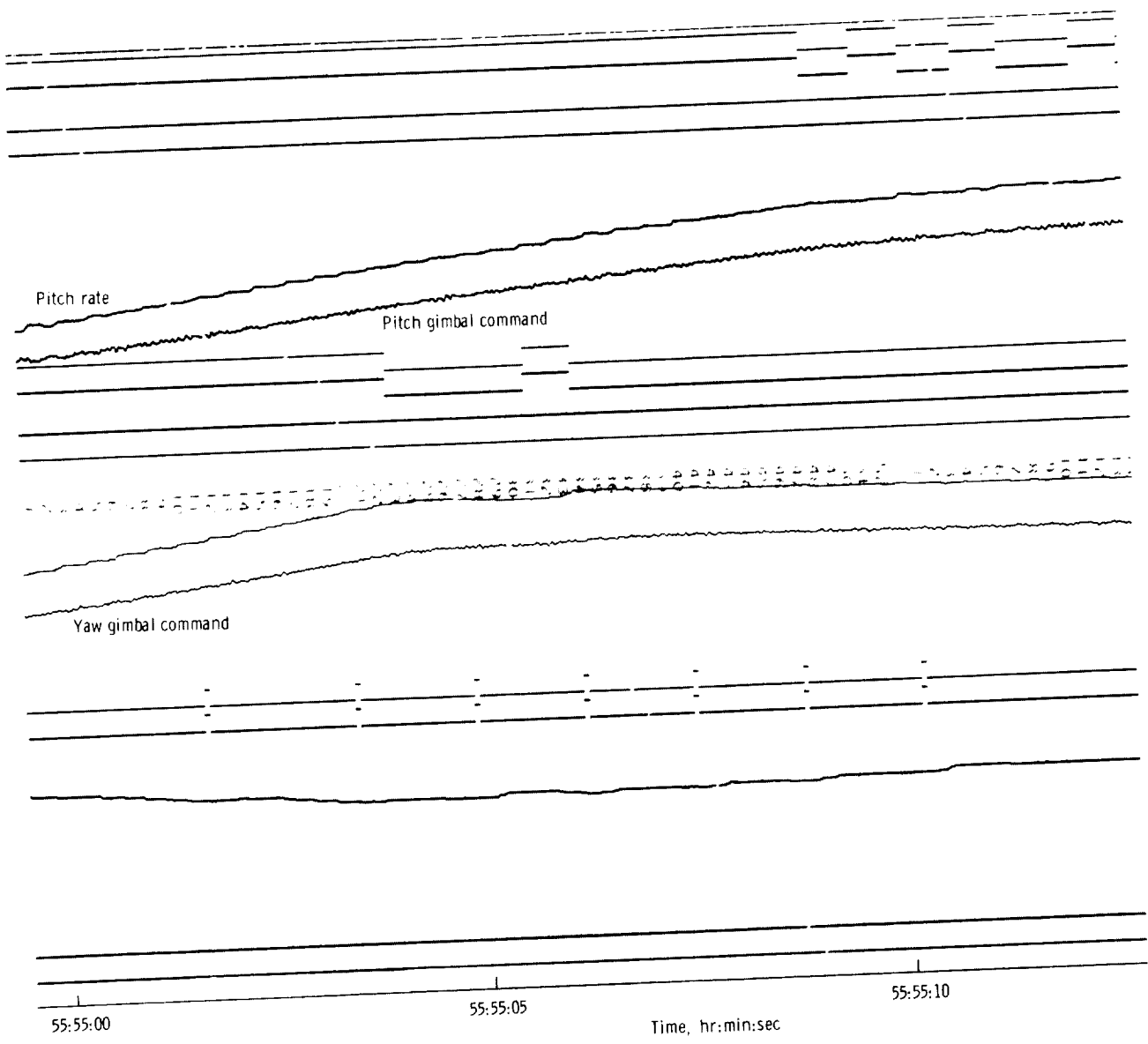

Figure B5-11.- Roll, pitch, and yaw rates.



+P Off — On
 +P Off — On
 -P Off — On
 -P Off — On

+Y Off — On
 +Y Off — On
 -Y Off — On
 -Y Off — On

+R Off — On
 +R Off — On

-R Off — On
 -R Off — On

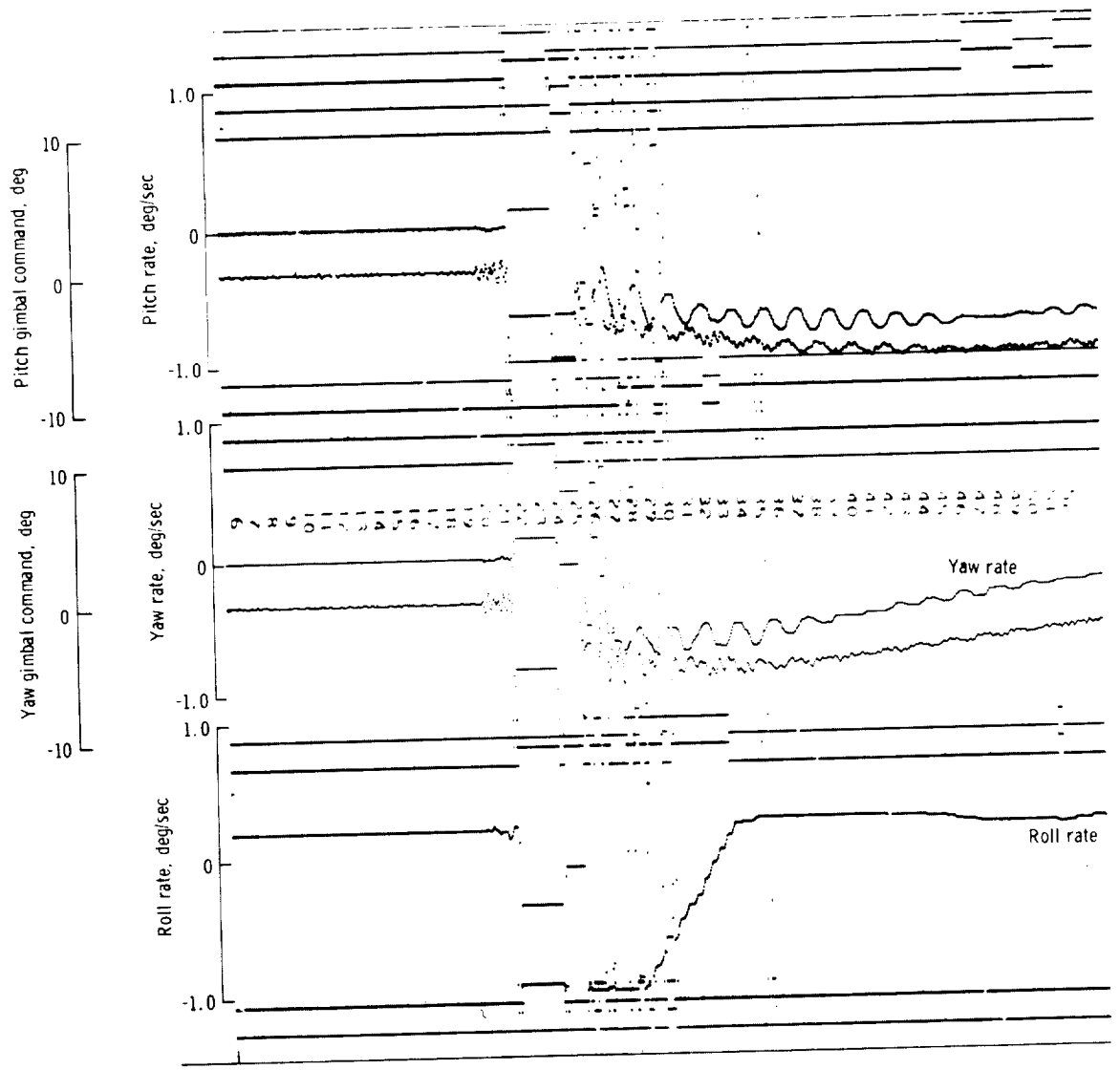

When transformed from platform coordinates to spacecraft coordinates, this represents a velocity change of 0.4 to 0.6 fps. The uncertainty in this measurement is due to the fact that the PCM system has an increment value of 0.2 fps. The velocity change was combined with the observed roll, pitch, and yaw rates; and a single equivalent impulse acting on the spacecraft calculated. The impulse components are:

X	500 lb-sec
Y	800 lb-sec
Z	-900 lb-sec

This indicates that the force was directed generally normal to the panel covering bay 4 of the service module. The extremely coarse data upon which this calculation is based makes it impossible to better define the force acting upon the spacecraft.

After recovery of data, the integrating accelerometer on the spacecraft stable platform also began to show an abnormal output. Calculations show that the force producing the acceleration amounted to about 60 pounds in the -X direction (retro thrust) over a period of about 8 minutes. At about the same time Commander Lovell reported seeing extensive venting of gases from the service module which definitely was not a normal or expected part of the spacecraft operation at that time. He later described the venting as continuous, looking like, ".....a big sheet with the sun shining on it--very heavy--like fine spray from a water hose," unlike gases and liquids vented during other planned spacecraft operations.

The radial velocity of the Apollo spacecraft relative to the Earth can be accurately determined by measuring the doppler shift of the S-band signal transmitted to Earth. Spacecraft velocity components normal to the line between the spacecraft and Earth cannot be determined by this method. The doppler velocity measurement is routinely made every 10 seconds and has an equivalent noise level of 0.015 fps.

Between 55:54:45 and 55:55:05 doppler measurements indicated a radial velocity increment of 0.26 fps. This is shown in figure B5-12. Following this abrupt change in velocity at approximately the time of telemetry loss, additional velocity changes were observed, as shown in figure B5-13. These velocity increments were caused in part by venting from the spacecraft and in part by firings of reaction control system jets.

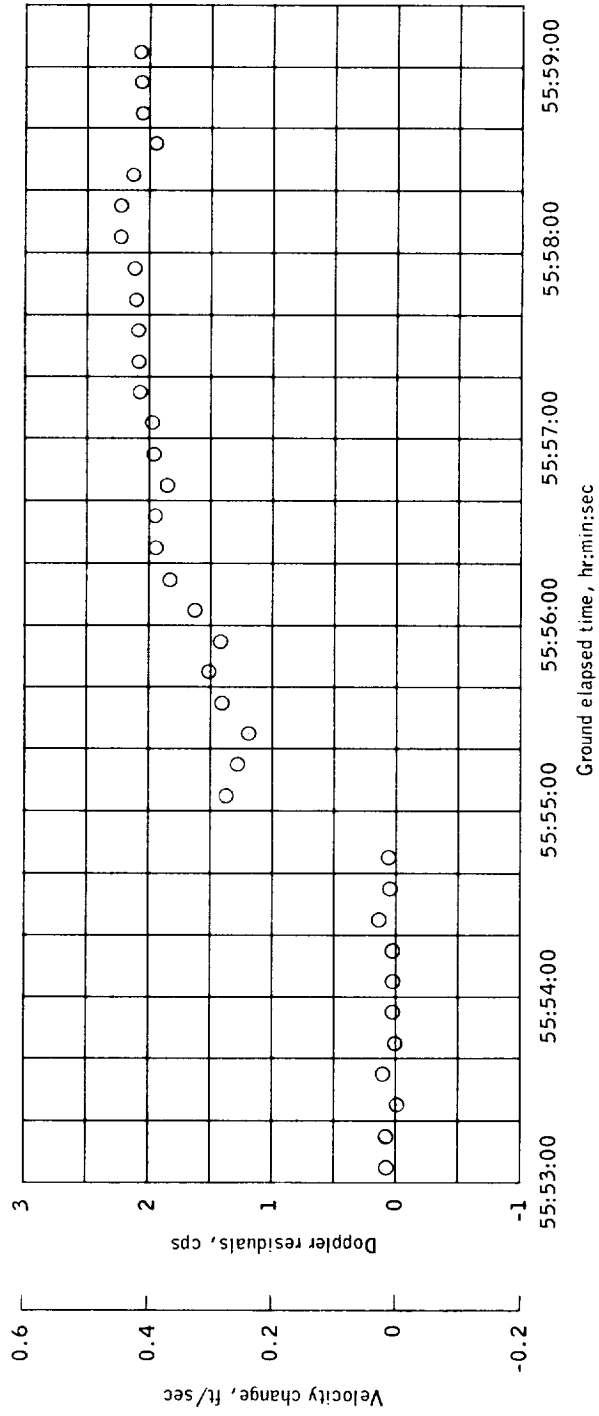

Figure B5-12.- Velocity increment at 55:54:53.

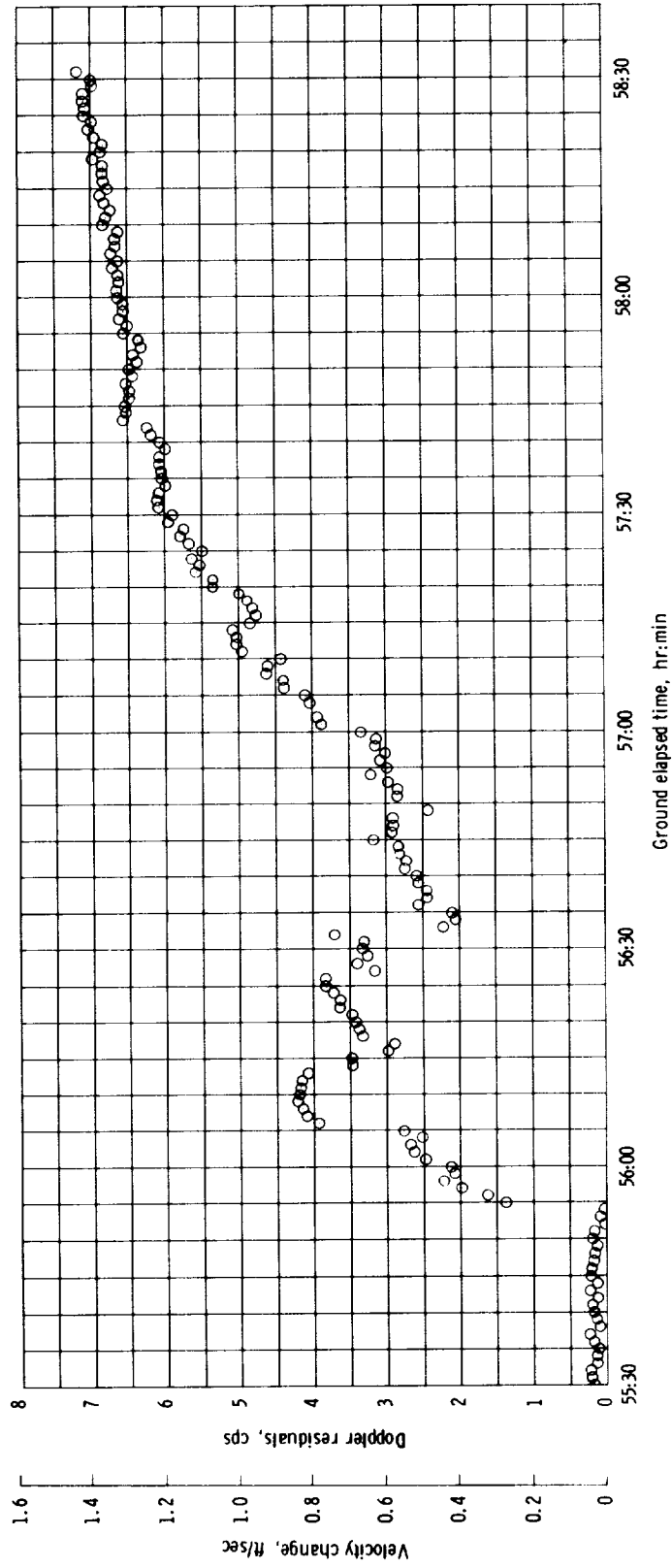

Figure B5-13.- Doppler tracking data.

The jet firings caused velocity increments rather than pure rotation rate changes because the jets did not always fire in opposed pairs. This resulted from the power system configuration in the spacecraft and closure of the quad C valves. (See Part B6 of this Appendix.)

TEMPERATURE CHANGES OBSERVED IN SERVICE MODULE

Following the recovery of telemetry data there were a number of temperature changes observed at various locations in the service module. The locations of all temperature sensors in the service module are shown in figure B5-14, and telemetered records from these sensors for the time period of 55:53:40 to 55:56:10 are shown in figure B5-15. From these temperature records the following conclusions can be drawn:

1. Both temperature measurements in bay 3, the bay adjacent to bay 4, increased after 55:54:55, whereas they had been steady prior to that time.
2. The corresponding temperature measurements in bay 5 showed much smaller increases. Bay 5 is adjacent to bay 4.
3. A change was observed in the service propulsion valve body temperature. This sensor, unlike many temperature sensors in the lower part of the service module, is not covered by multiple layers of insulation.
4. Four sensors located in close proximity on the separator between bay 4 and bay 5 showed rapid temperature rises of small magnitude immediately after the recovery of telemetry data. These sensors measure the temperatures of fuel cells 1 and 3 radiator inlets and outlets.
5. The temperature of quad C and D reaction control engines continued the same rate of rise after data loss as before data loss.

FAILURE OF CRYOGENIC OXYGEN SYSTEM

The telemetered quantities from cryogenic oxygen tank no. 2 were all off-scale following the recovery of telemetry at 55:54:55. Since no accurate assessment of the damage to this tank has been possible, the readings of the sensors within it are in doubt. The temperature was reading full-scale high and continued this way until 55:55:49,

This page left blank intentionally.

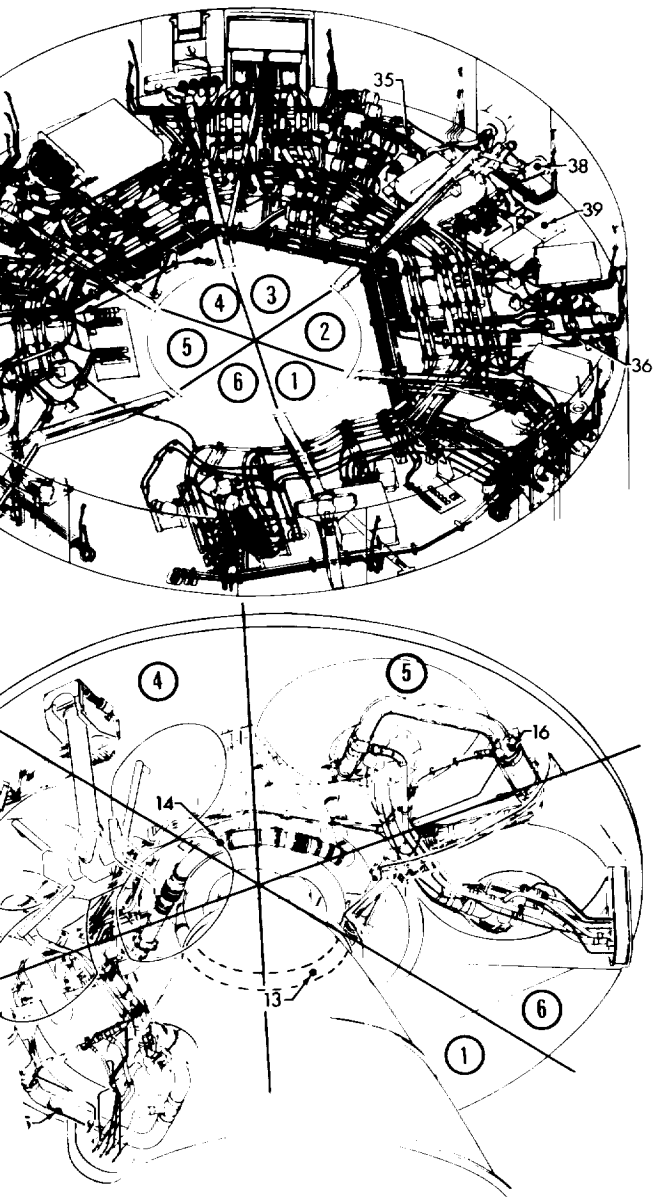

Service module temperature measurements			
Number	Measurement number	Title	Remarks
1	SC2090	Fuel cell 1 radiator inlet	
2	SC2091	Fuel cell 2 radiator inlet	
3	SC2092	Fuel cell 3 radiator inlet	
4	SC2087	Fuel cell 1 radiator outlet	
5	SC2088	Fuel cell 2 radiator outlet	
6	SC2089	Fuel cell 3 radiator outlet	
7 ^a	SA2377	Bay 2 oxidizer tank surface	Opposite 9
8	SA2378	Bay 3 oxidizer tank surface	
9	SA2379	Bay 5 fuel tank surface	Opposite 8
10 ^a	SA2380	Bay 6 fuel tank surface	Opposite 8
11	SP0002	Helium tank	
12	SP0045	Service propulsion valve body	
13	SP0048	Service propulsion fuel feed line	
14	SP0049	Service propulsion oxidizer feed line	
15	SP0054	Service propulsion oxidizer line	
16	SP0057	Service propulsion fuel line	
17 ^a	SP0061	Service propulsion injector flange 1	Opposite 18 on flange
18	SP0062	Service propulsion injector flange 2	
19 ^a	SR5013	Reaction control helium tank quad A	Bay 6 opposite 21
20 ^a	SR5014	Reaction control helium tank quad B	Bay 2 opposite 22
21	SR5015	Reaction control helium tank quad C	Bay 3
22	SR5016	Reaction control helium tank quad D	Bay 5
23 ^a	SR5065	Reaction control engine package quad A	Bay 6 opposite 25
24 ^a	SR5066	Reaction control engine package quad B	Bay 2 opposite 26
25	SR5067	Reaction control engine package quad C	Bay 3
26	SR5068	Reaction control engine package quad D	Bay 5
27	SC0043	Hydrogen tank 1	
28	SC0044	Hydrogen tank 2	
29	SC2084	Fuel cell 1 skin	Internal
30	SC2085	Fuel cell 2 skin	Internal
31	SC2086	Fuel cell 3 skin	Internal
32	SC2081	Fuel cell 1 condenser exhaust	Internal
33	SC2082	Fuel cell 2 condenser exhaust	Internal
34	SC2083	Fuel cell 3 condenser exhaust	Internal
35	SF0260	Environmental control primary radiator inlet	
36	SF0262	Environmental control secondary radiator inlet	
37 ^a	SF0263	Environmental control secondary radiator outlet	Bay 6 opposite
38	ST0840	Nuclear particle detector	
39	ST0841	Nuclear particle analyzer	
40	SC0041	Oxygen tank 1	
41	SC0042	Oxygen tank 2	

^a Located on opposite side of vehicle and not shown in the view.

Figure B5-14.- Temperature sensor location in Apollo service module

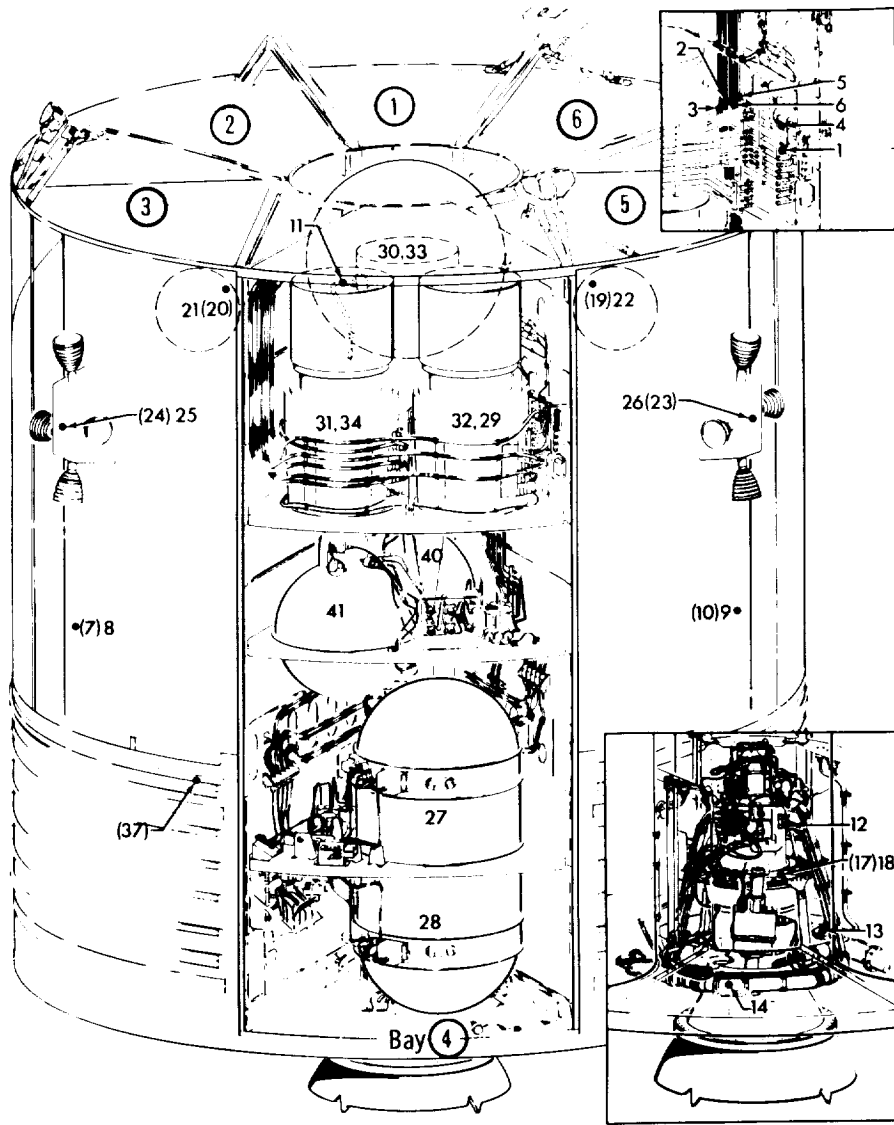

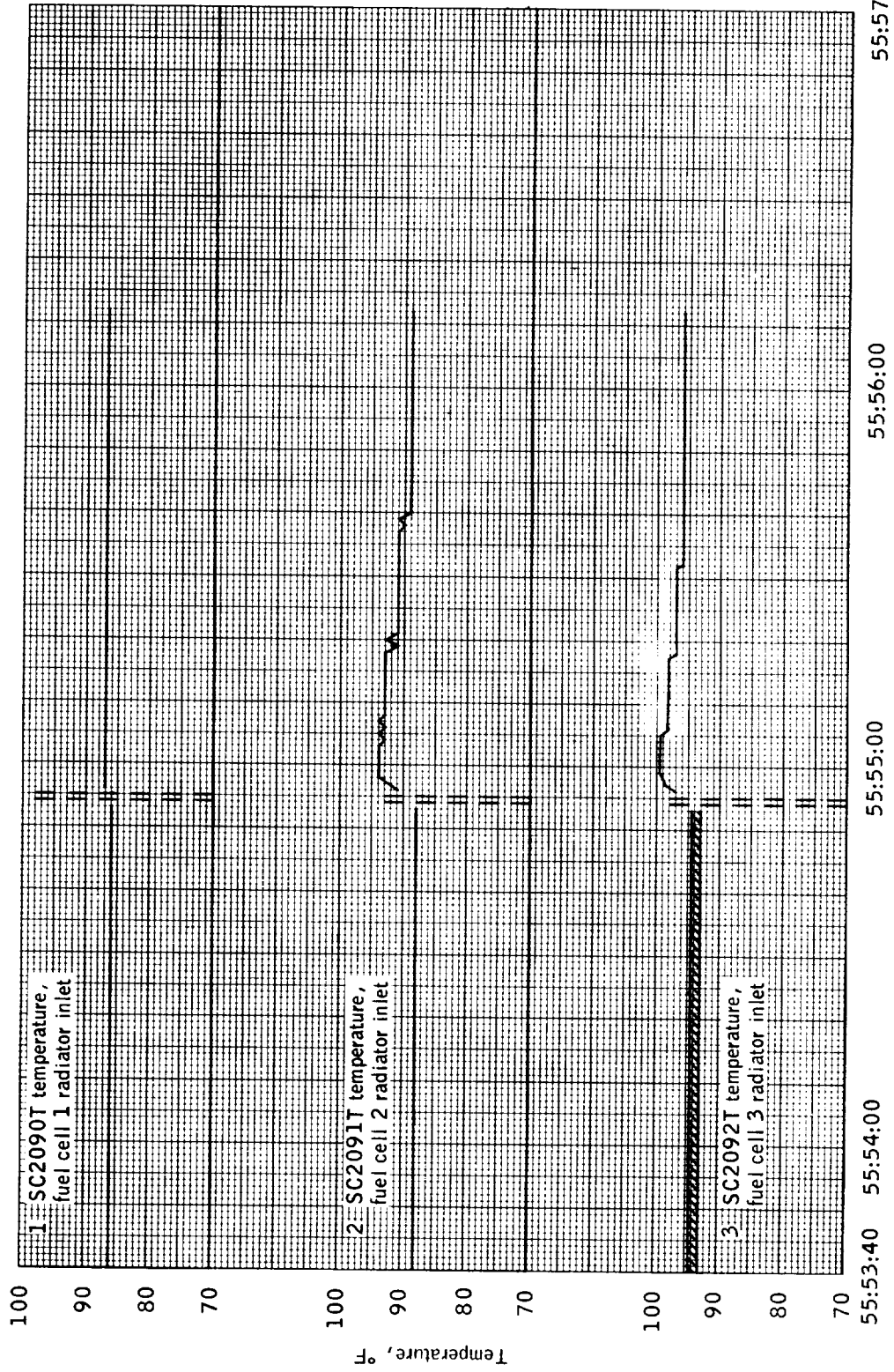

(a) Radiator inlet temperatures.

Figure B5-15.- Service module temperature history.

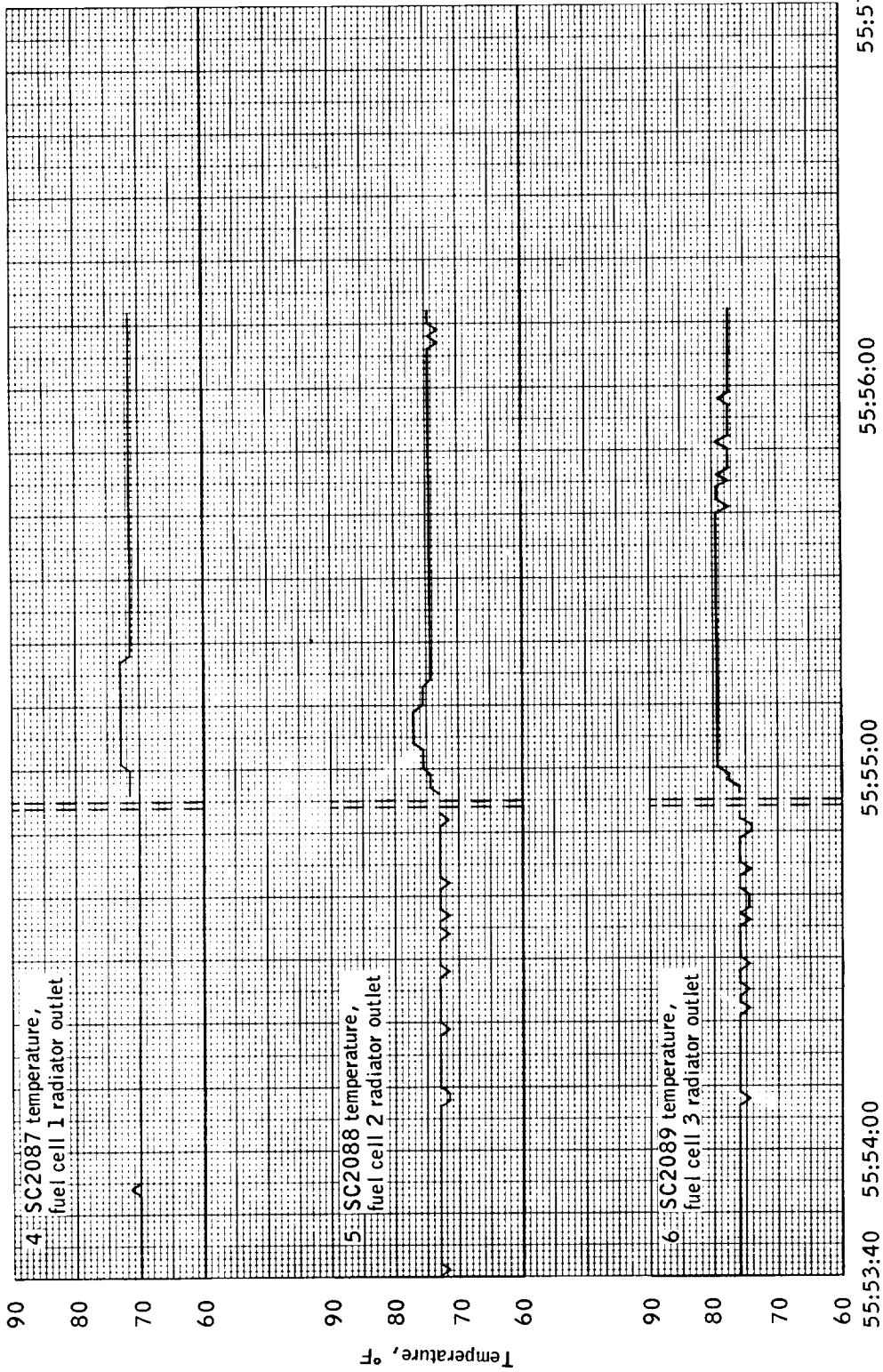

(b) Radiator outlet temperatures.

Figure B5-15.- Continued.

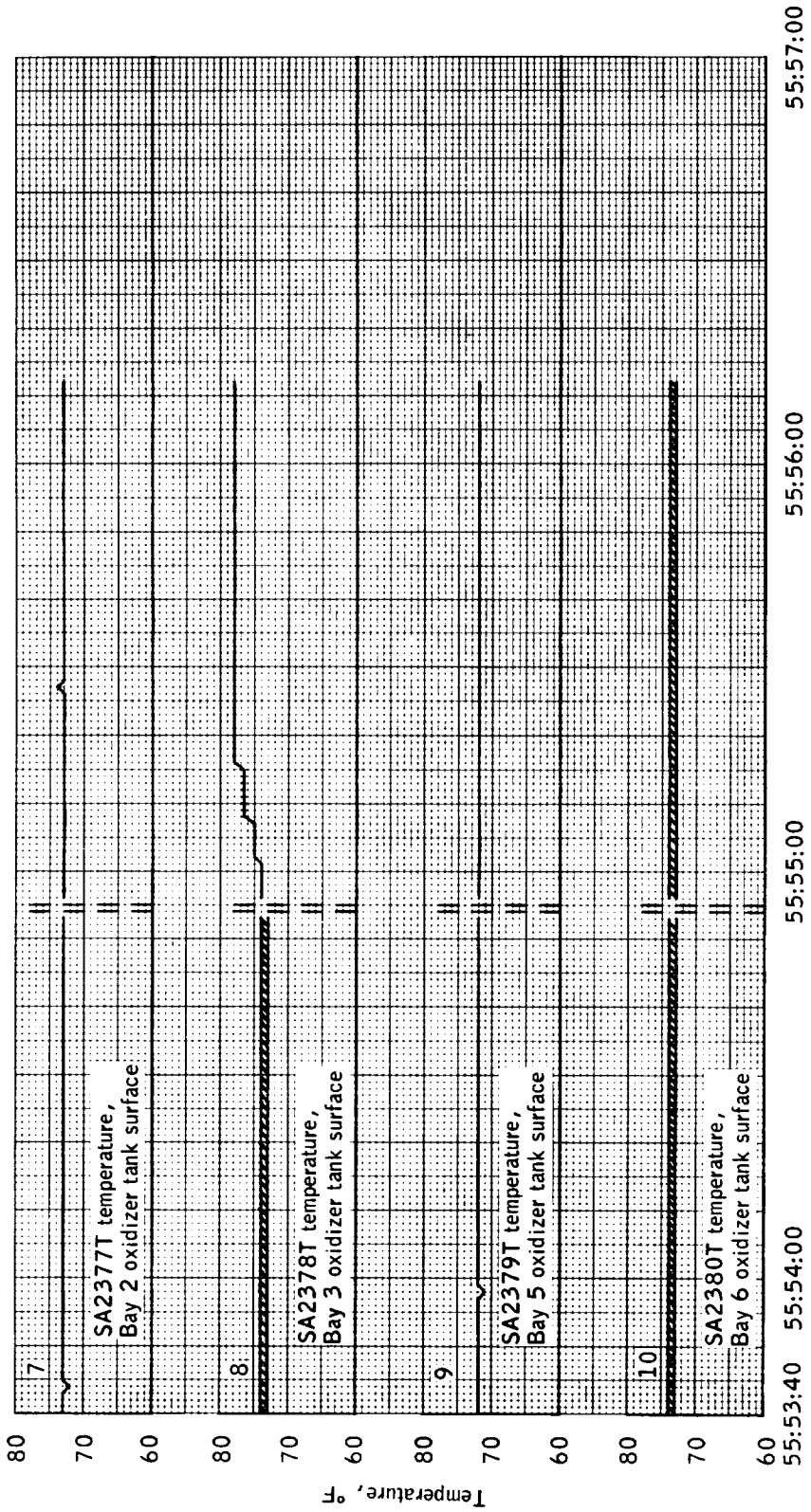

(c) Tank surface temperatures.

Figure B5-15.- Continued.

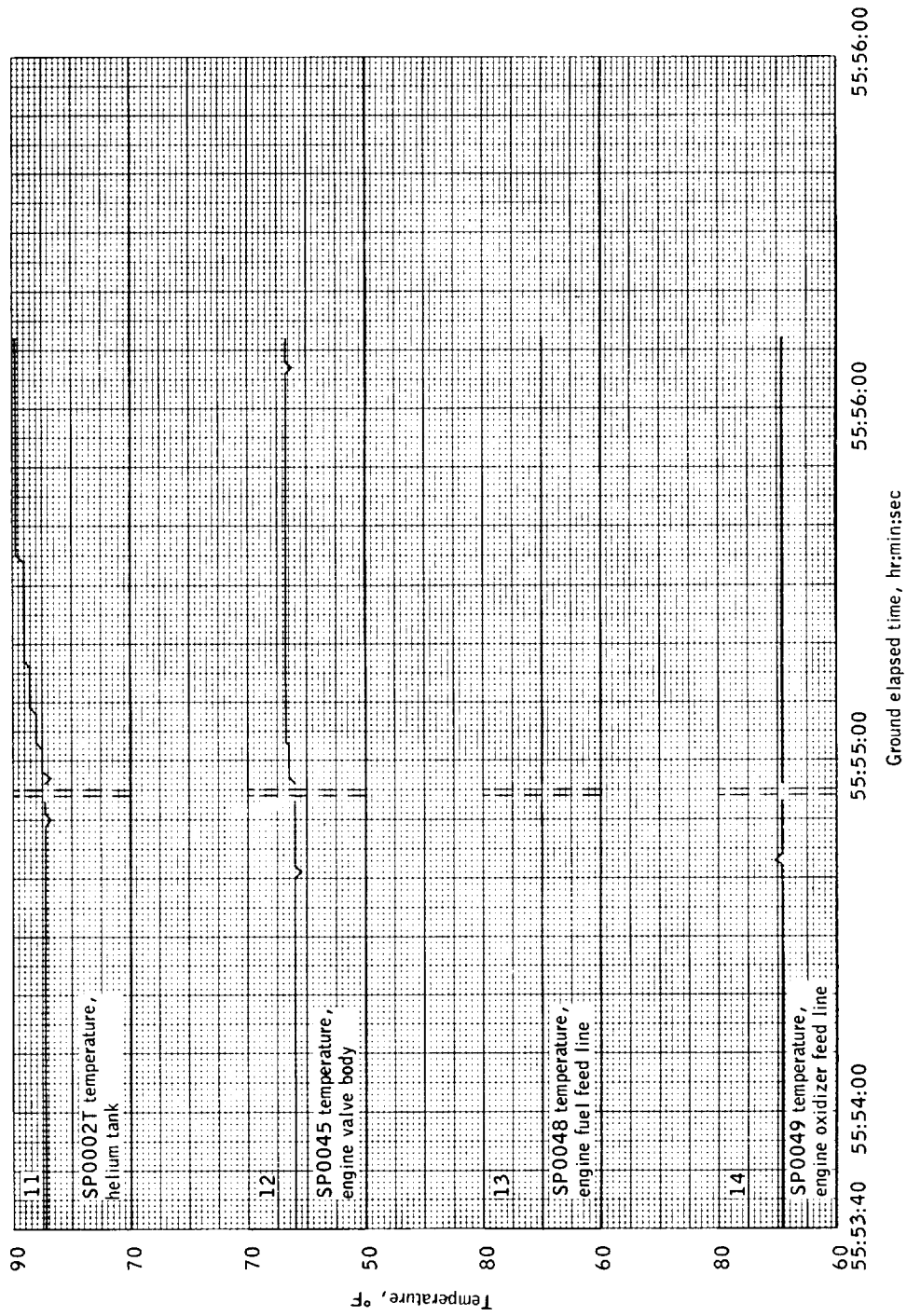

(d) Service propulsion temperatures, group 1.

Figure B5-15.- Continued.

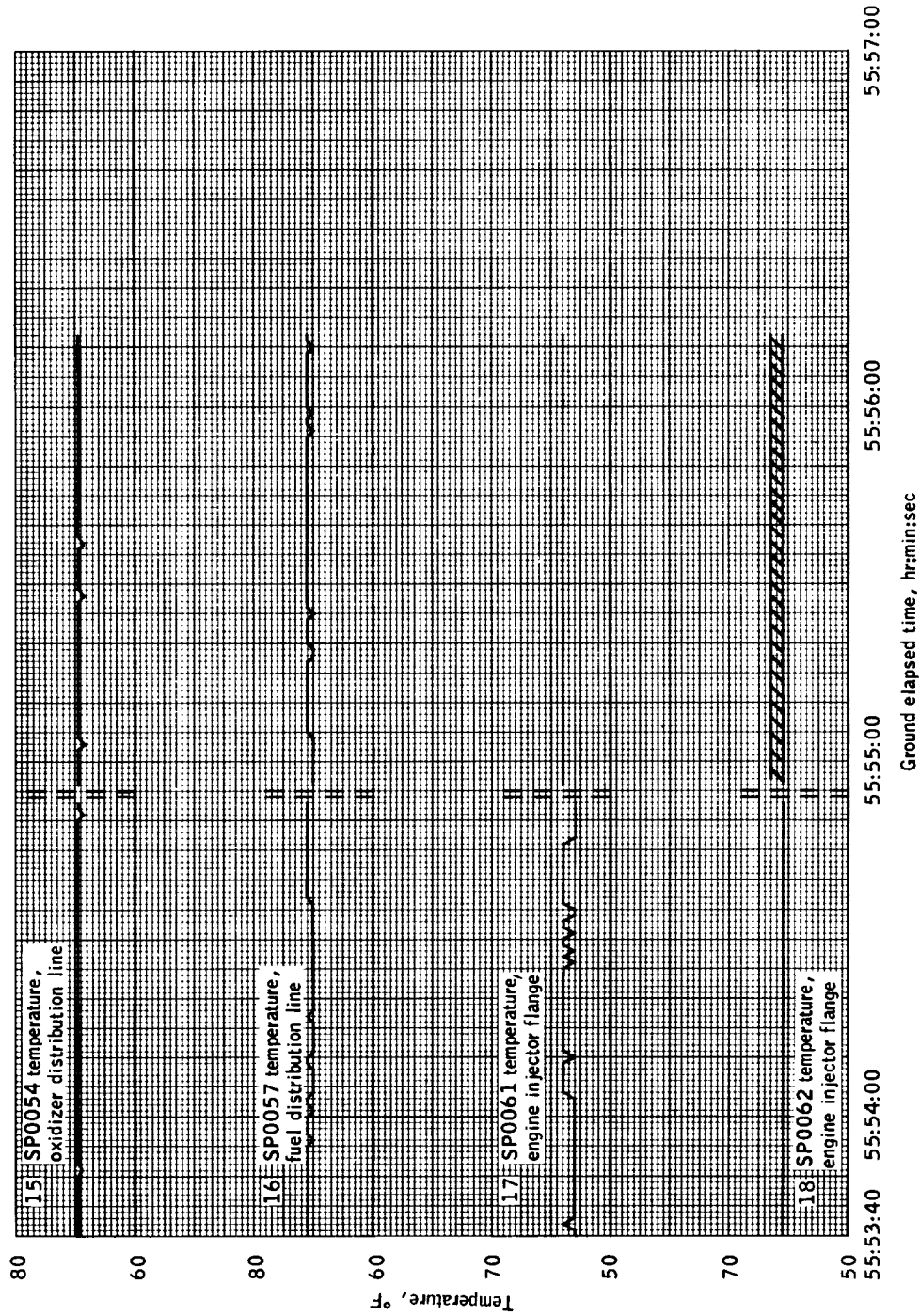

(e) Service propulsion temperatures, group 2.

Figure B5-15.- Continued.

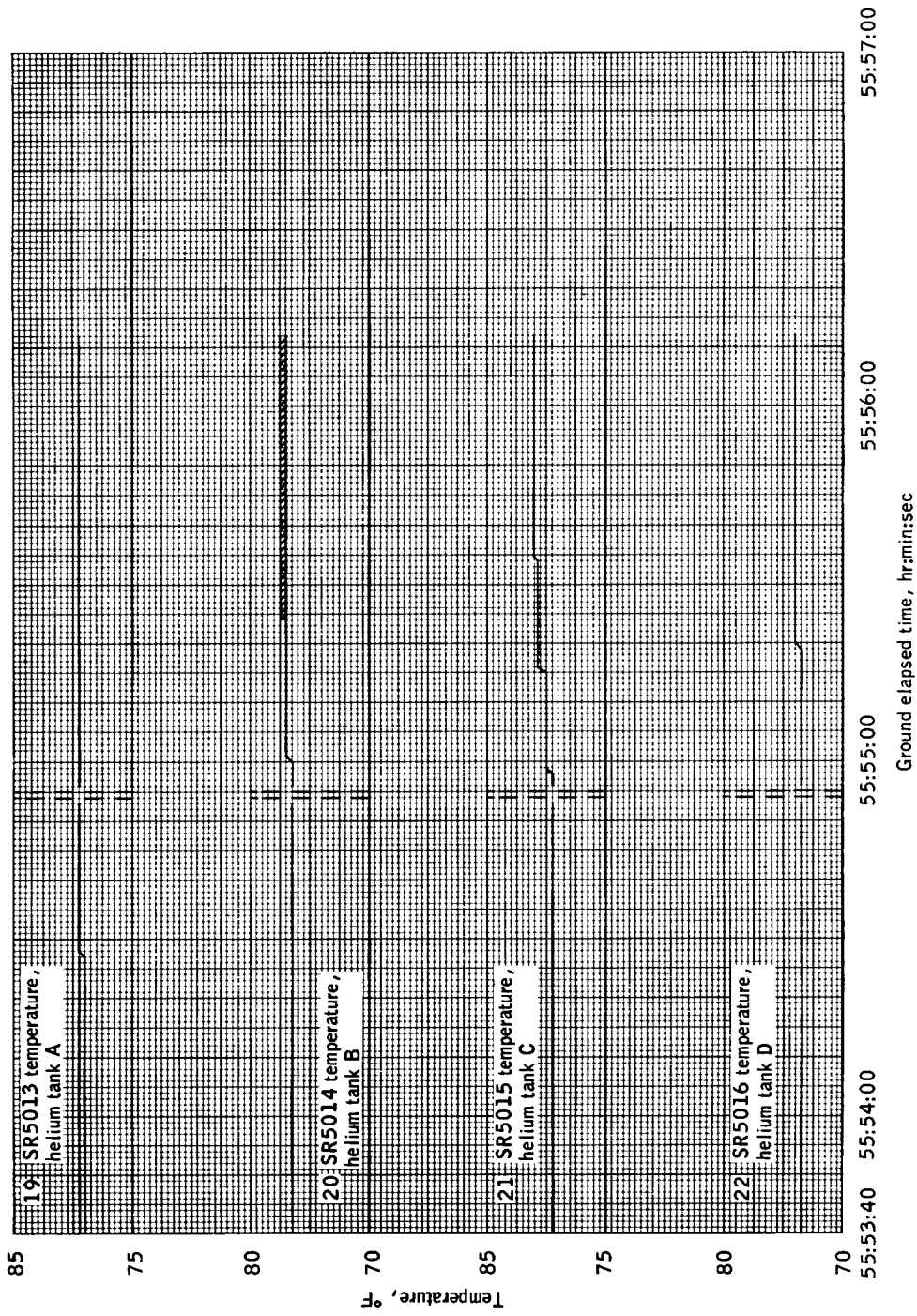

(f) Reaction control helium tank temperatures.

Figure B5-15.- Continued.

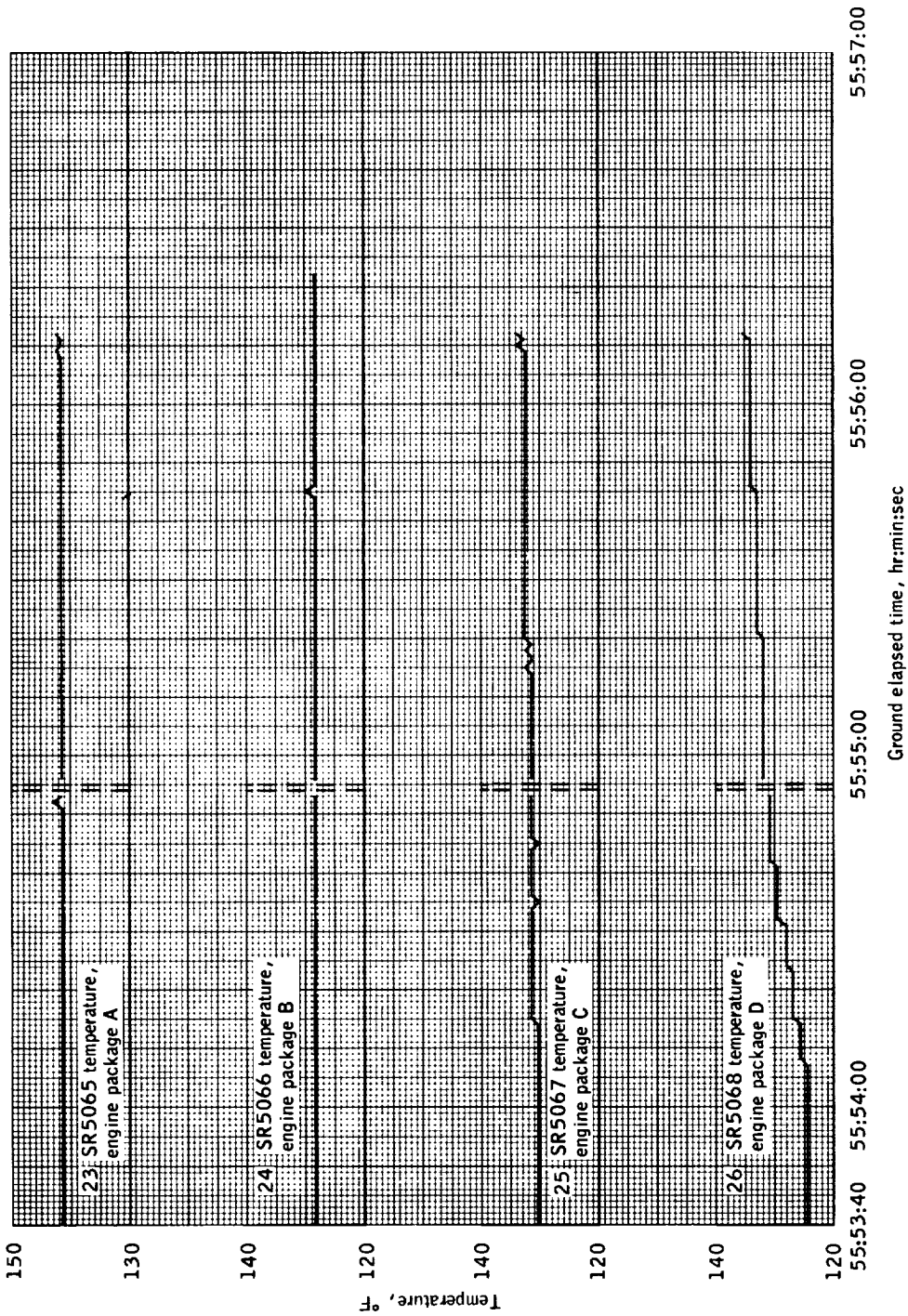

(g) Reaction control engine package temperatures.

Figure B5-15.- Continued.

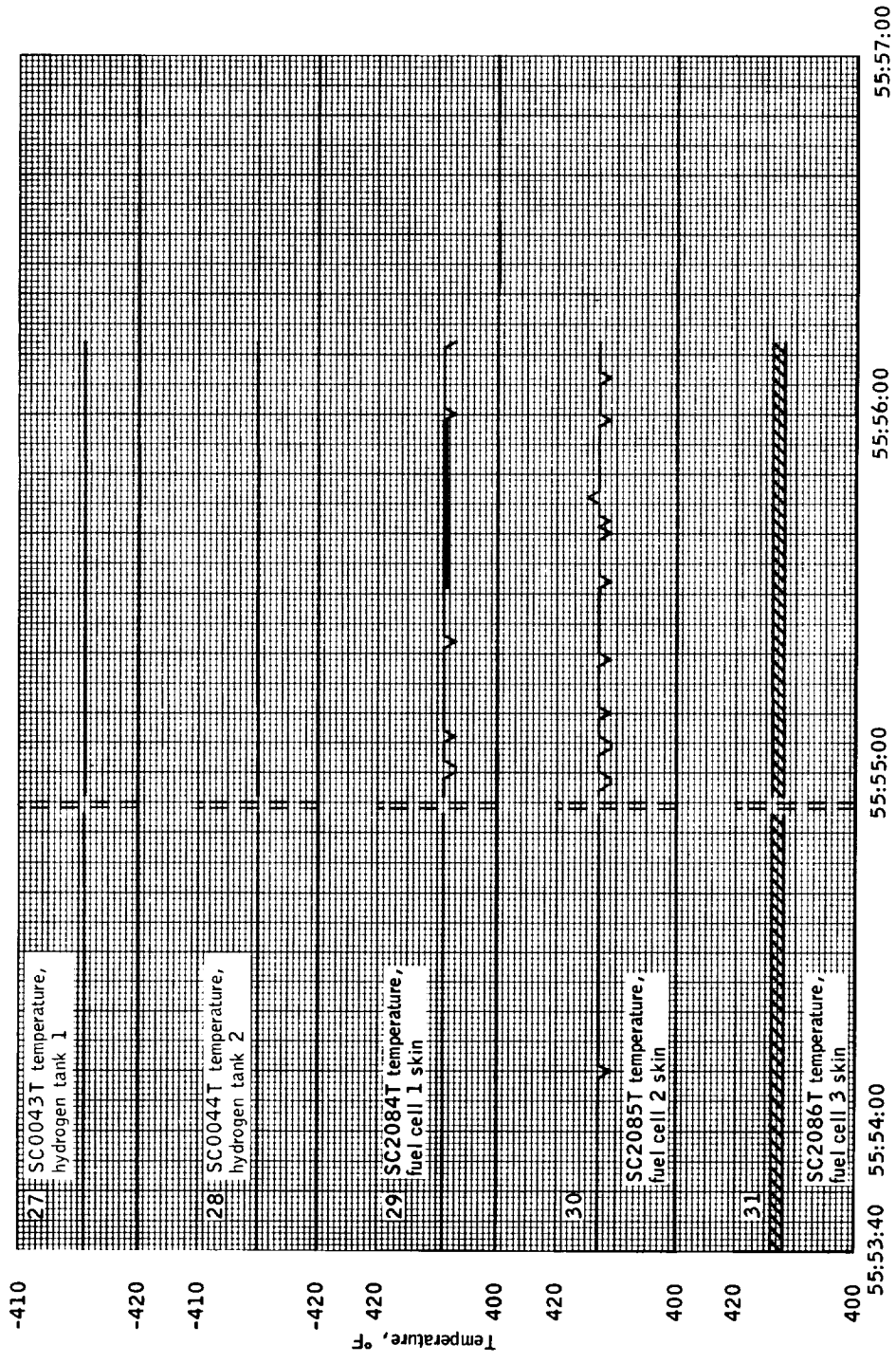

Ground elapsed time, hr:min:sec
 (h) Fuel cell skin temperatures.

Figure B5-15.- Continued.

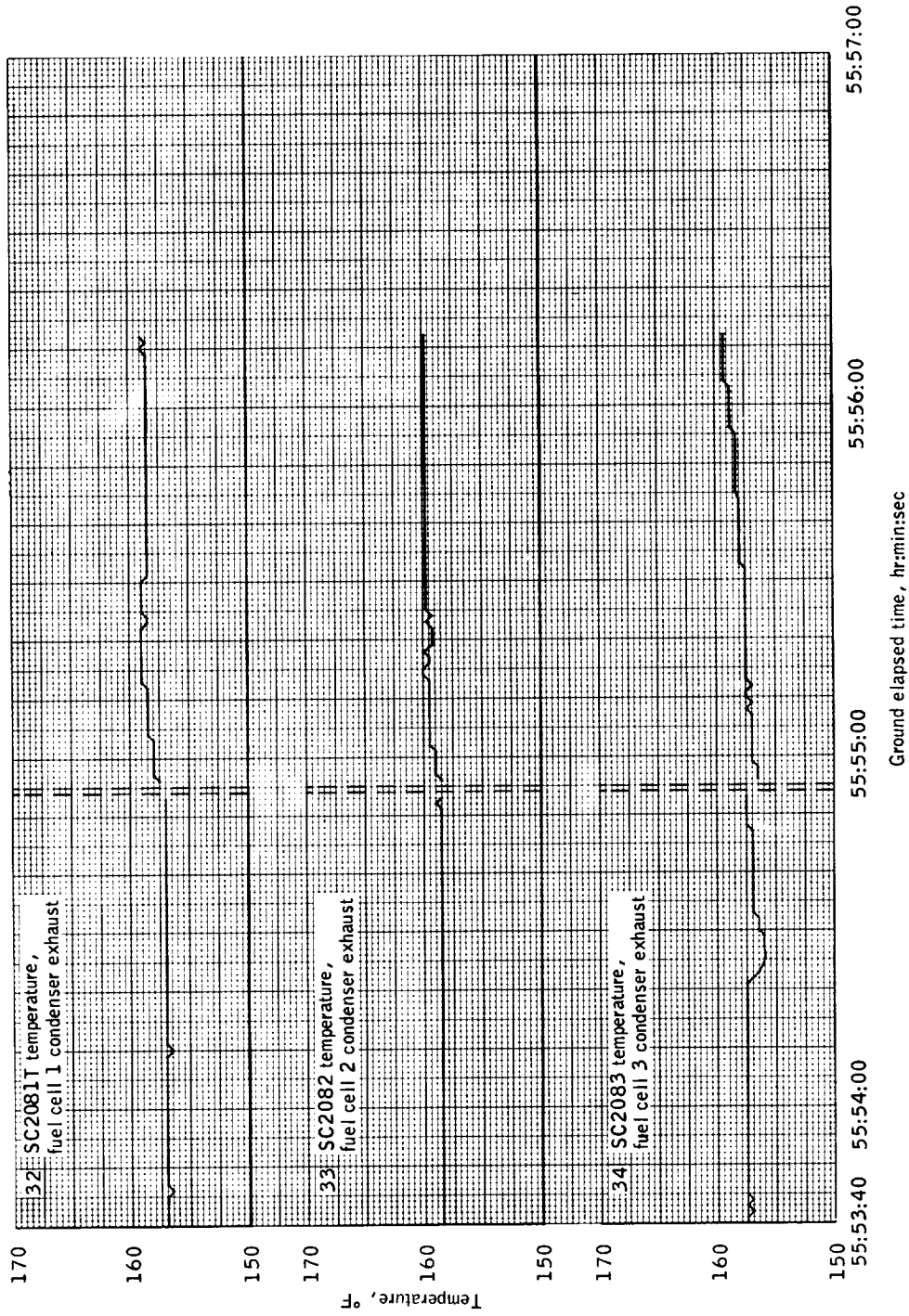

(i) Fuel cell condenser exhaust temperatures.

Figure B5-15.- Continued.

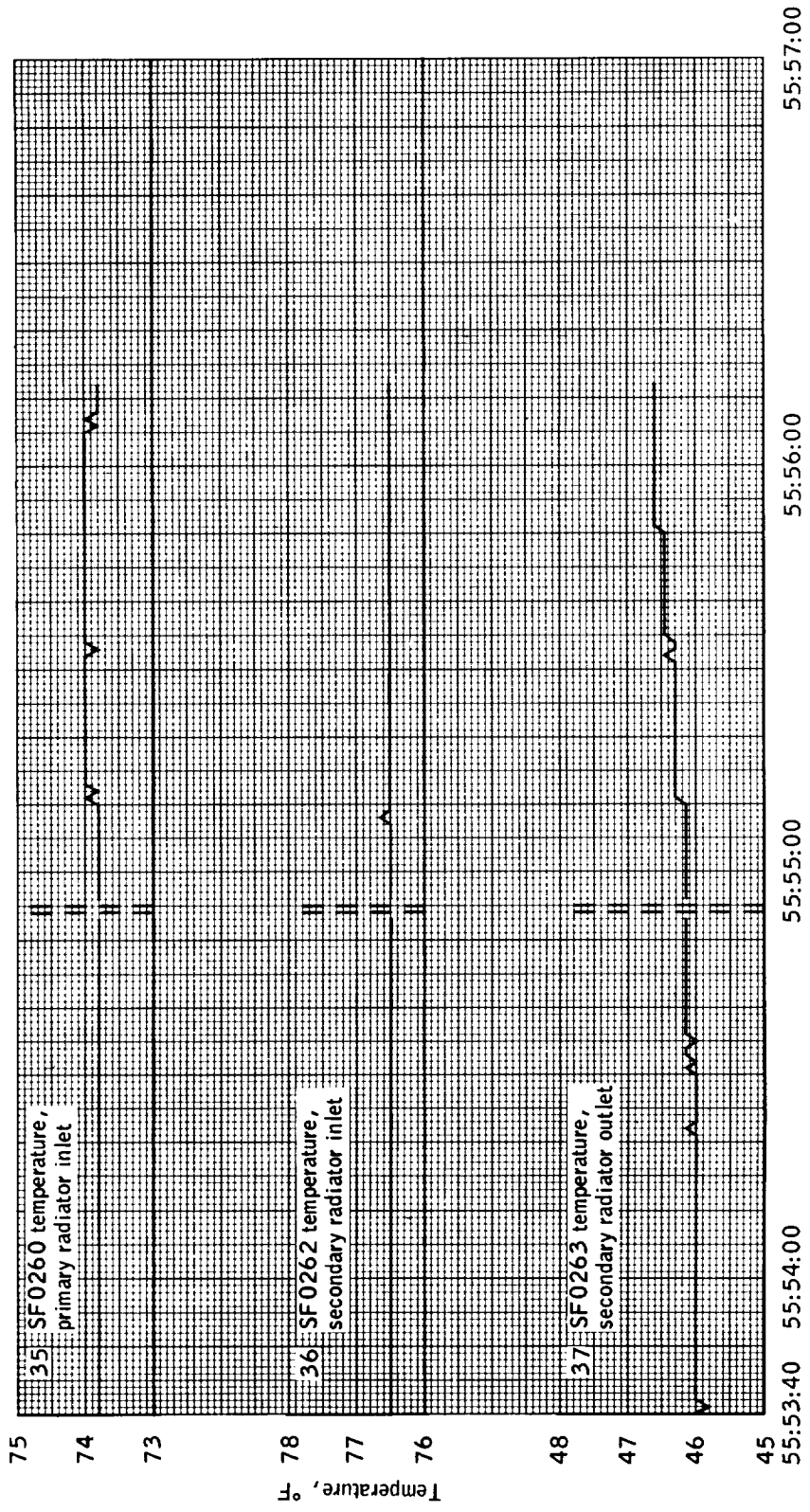

Ground elapsed time, hr:min:sec

(j) Environmental control radiator temperatures.

Figure B5-15.- Concluded.

when it began a steady decrease which ended at 55:56:48 in an off-scale-low reading. This behavior is a possible result of a failure of the sensor. For an explanation of possible failure modes of this sensor, see Part B7 of this Appendix. The pressure of cryogenic oxygen tank no. 2, sensed remotely, read off-scale low and continued to show this reading. Off-scale low for this sensor represents a pressure of 19 psia or below.

The quantity gage read full-scale high after telemetry recovery and continued in this state until 55:56:38 when it began oscillating in an erratic manner. The oscillation continued until 55:57:47 when the gage assumed an off-scale-low reading. The quantity gage and its failure modes are described in Part B7 of this Appendix.

The pressure in cryogenic oxygen tank no. 1 had dropped from 879 psia to 782 psia during telemetry loss. This pressure continued to drop at a slow rate for about 2 hours until it was insufficient for operation of the last remaining fuel cell.

The heaters in both cryogenic oxygen tanks were off prior to telemetry loss as a result of the high pressure in tank no. 2. After telemetry recovery the total fuel cell current indicated an increase of about 5 amperes after known loads had been accounted for. The low pressure levels in both oxygen tanks should have caused both heaters to be on at this time. The total current drain by the heaters in any one tank is about 5 amperes. It therefore appears that the heaters in one tank had come on since telemetry loss and were operating at this time. It is possible that the heaters in cryogenic oxygen tank no. 2 were either physically open-circuited before or at the time of the bang.

Additional evidence that the heaters in only one tank were on can be obtained by observing that at 56:19:03 the spacecraft dc current decreased 5 amperes. This is the time at which the crew began to power down the spacecraft according to the emergency powerdown checklist. If heaters in both oxygen tanks had been on at that time, the current should have decreased approximately 11 amperes instead of the observed 5 amperes.

OPERATION OF THE ELECTRICAL POWER SYSTEM

Following the period of telemetry loss, a high-current condition existed on the fuel cell outputs for 19 seconds. In the same time period, the two dc main voltages were approximately 0.9 volt lower than their previous values. By 55:55:14 the voltages and currents had become normal. The observed currents during the 19-second period have been

correlated with reaction control system jet firings and an inertial measurement unit heater cycle. The excellent correlation indicates that no unaccountable loads were added to the power system during this time period.

The crew observed a master caution and warning signal 1 or 2 seconds after the bang, along with an indication of undervoltage on dc bus B. The master caution and warning was turned off at 55:55:00.

Within 5 seconds after the resumption of telemetry data, the oxygen flow rates to fuel cells 1 and 3 had decreased to approximately 20 percent of their prior values. These flow rates remained at a sufficiently low level to cause failure of fuel cells 1 and 3 at approximately 55:58. The most probable explanation for the reduced oxygen flow rates is that at the time of the bang a sufficiently intense shock occurred to close the valves in the oxygen lines feeding fuel cells 1 and 3.

There is sufficient volume in the oxygen lines between the supply valves and the fuel cells to maintain fuel cell operation for the observed time of about 3 minutes. The intensity of the shock is indicated by the fact that the reaction control system valves on quad C were closed. Tests on these valves have shown that 80g for 10 milliseconds will cause them to close. Tests on the oxygen supply valves have shown that a shock of 86g for 11 milliseconds will cause them to close.

The crew was not alerted to the abnormally low flow rate of oxygen to fuel cells 1 and 3 because the hydrogen supply valves had not been closed. The valve closure indicator is only activated when both the oxygen and hydrogen supply valves to a fuel cell are closed. The first indication to the crew that the power system was failing came at 55:57:39 when the master caution and warning was triggered by a main bus B undervoltage, occasioned by the failure of fuel cell 3. Main bus B voltage dropped to an unusable level within 5 seconds, causing ac bus 2 to drop to zero at 55:57:45.

The crew quickly checked the ac and dc voltage levels, recognized that ac bus 2 had failed, and responded by switching ac loads from ac bus 2 to ac bus 1. This heavier load on ac bus 1 was reflected as a heavier load on dc main A, causing it to drop in voltage. At 55:58:06, a dc main A undervoltage master caution and warning was triggered as the main voltage dropped to between 25 and 26 volts. Shortly afterwards, at approximately 55:58:06, fuel cell 1 failed, placing the entire load of dc main A on fuel cell 2. Fuel cell 2 was now called upon to supply a current of 50 amperes.

Fuel cell 2 remained the major source of electrical power in the command module for the next 2 hours. During this time, telemetry

continued to indicate a decreasing cryogenic oxygen pressure in tank no. 1. At 58:04 battery A was connected to main bus A and fuel cell 2 was removed from operation when oxygen flow became insufficient.

PART B6

POSTINCIDENT EVENTS

The description of postincident events is presented in two sections. The first, entitled "Immediate Recovery," describes the flightcrew and flight controller actions during the 2-1/2-hour period following the incident. This section is primarily concerned with actions of the flightcrew and flight controllers during this period in response to the immediate problems caused by the spacecraft failures. The long-term problems addressed by Mission Control are described in the second section, entitled "Plans and Actions Taken to Return the Crew to Earth."

IMMEDIATE RECOVERY

The first indication in the Mission Control Center of any problem in the spacecraft came from the Guidance Officer who reported that he had observed a "hardware restart." This term describes the action of the on-board computer when certain computer electrical problems occur, such as a reference voltage or an oscillator frequency getting out of tolerance. When this occurs, the computer stops its computations and recycles to a specified location in the program. Computations will not resume until the out-of-tolerance condition is cleared. At 55:55 this event occurred so rapidly that the flight controllers did not observe the computer halt; they only saw that it had occurred.

The report of the hardware restart was followed almost immediately by the crew's report, "I believe we've had a problem here." This was followed quickly by a statement from the crew that they had a main bus B undervolt indication from the master caution and warning (MC&W) system. Flight controllers responsible for the electrical, environmental control, and instrumentation systems immediately searched their displays, but at that time there were no indications of any electrical problems, all voltages and fuel cell currents appeared normal. Apparently, the main bus B undervolt problem was a transient that had cleared up, for the crew next reported the bus voltages were "looking good." However, the flight controllers knew that all was not well because the oxygen tank measurements indicated some major problems in this system, or its instrumentation.

The next report in Mission Control was from the flight controller responsible for the communication systems. He stated that the high-gain antenna on the spacecraft had unaccountably switched from narrow beam width to wide beam width at approximately the same time the problem had occurred.

In sorting out these pieces of information, the flight controllers initially suspected that there had been an instrumentation failure. However, with the subsequent failure of main bus B and ac bus 2 it became more obvious that a serious electrical problem existed. The flight controllers considered the possibility that a short had occurred, and that this was in some way related to the unusual behavior of the high-gain antenna. The rapid rate at which so many parameters in the electrical and cryogenic system had changed state made it impossible to tell which were causes and which were effects.

The Mission Control Center response to the situation is described in this section of the report. The time interval covered is from 55 hours 58 minutes ground elapsed time (55:58 g.e.t.) to 58:40 g.e.t., when all power was removed from the command module (CM). The major portion of the activities of both the flightcrew and the flight controllers in this time period was directed toward (1) evaluation and management of the electrical and cryogenic oxygen problems; (2) maintenance of attitude control; and (3) activation of the lunar module (LM). A chronological listing of all significant actions is presented first. This is followed by a more detailed description of the three categories of activities mentioned above.

Chronology of Spacecraft Reconfiguration Actions

This listing was obtained from transcripts of air-to-ground voice records (ref. 2) and the "Flight Director" loop in the Mission Control Center. Additional information was obtained from interviews with members of the flight control team. Some editing has been done to eliminate the description of routine actions which obviously have no significance to this investigation: examples are omni antenna switching and the loading of weight and inertia information in the digital autopilot. The times at which specific actions are listed are only approximately correct, (± 1 minute) since there was no precise time correlation available.

55:59 - Fuel cell main bus connection.- Mission Control requested the crew to connect fuel cell 1 to main bus A and fuel cell 3 to main bus B. Although there was no direct evidence the crew had changed the fuel cell and main bus configuration, the flight controller believed that this might be the case. The configuration prior to the loss of main bus B was as follows: fuel cell 1, main A; fuel cell 2, main A; and fuel cell 3, main B.

56:03 - Entry battery on line.- The crew placed entry battery A on main bus A to increase the bus voltage. Mission Control was just about to ask that this be done. The bus voltage was approximately 25 volts, which is about 1-1/4 volts below the MC&W trip limit.

56:08 - Open circuit fuel cell 1.- Mission Control requested the crew to open circuit fuel cell 1. Flight controllers did not understand the problems with the fuel cells; the data were confusing and incomplete. In an effort to get some new information, the controllers decided to take all loads off fuel cell 1 to see if it would behave any differently. It was not putting out any power so there was no reason to leave it connected to the main bus.

56:11 - Power RCS jets from main bus A.- Mission Control requested the crew to position some RCS jet select switches to main A power. All of the quad C jets and B-3 and B-4 jets had been powered from main bus B and since that bus had no power on it, they could not fire except by the "Direct" coils. By switching these jets to main bus A, there was at least one jet available for automatic control in each direction about each axis.

56:14 - Start emergency powerdown.- Mission Control advised the crew to use page 1-5 of their Emergency Powerdown Checklist, part of the Flight Data File (ref. 7) carried by the crew. Mission Control wanted to get the current on main bus A reduced by at least 10 amps, and then take the entry battery A off-line. The list down to "BMAG #2-off" was to be turned off; it included the following: all cryo tank heaters and fans, G&N optics power, potable water heater, SPS line heater, SPS gaging, suit compressor, all fuel cell pumps, SMRC heaters, ECS radiator heaters, and SPS gimbal motors.

56:23 - Power AC bus 2 with inverter (INV) 1.- The crew was requested to power both ac busses with inverter no. 1. The primary purpose was to get telemetry data from oxygen tank no. 2 which is powered by ac bus 2 only.

56:24 - Turn fuel cell no. 2 pump on.- The crew had turned the pumps off in following the emergency powerdown list. The pumps circulate glycol and hydrogen for internal cooling in the fuel cells. They could have been left off for an hour or more, but fuel cell performance would have been degraded.

56:30 - Select main bus A power to RCS jet A-3.- The spacecraft was drifting in pitch without any apparent control. Quad C, which should have been controlling pitch, did not seem to be firing at all. To try to regain control in pitch, the quad A-3 jet was switched to main bus A power.

56:33 - Open circuit fuel cell no. 3.- Same reason as for open circuit fuel cell no. 1.

56:33 - Reconfigure quad B and D thrusters.- Flight control felt that a quad B thruster might be causing the spacecraft attitude deviations, and asked the crew to take off all power to the quad B jets. To compensate

for quad B being off, all jets in quad D were selected to be powered from main bus A.

56:34 - Battery A taken off line.- The bus loads had been reduced sufficiently to allow fuel cell 2 alone to keep the bus voltage up. It was highly desirable to use the battery as little as possible, because there was no guarantee it could be recharged.

56:35 - Isolate the surge tank.- The crew was directed to isolate the CM oxygen surge tank. The purpose was to preserve an oxygen supply for reentry.

56:38 - Oxygen tank no. 1 heaters and fans.- Mission Control requested the crew to turn on the heaters in cryogenic oxygen tank no. 1 in an effort to build up the tank pressure. The current was observed to increase about 5 amperes, indicating they did come on. About 2 minutes later, since there was no increase in pressure, the crew was asked to turn on the fans in this tank.

56:45 - BMAG 2 off.- In an effort to further conserve power, the second BMAG was powered down.

56:51 - Turn off thruster C-1.- Thruster C-1 seemed to be firing very frequently without any apparent reason. The crew was requested to turn off all power to this thruster. The attitude disturbances were noted to have been virtually ended at about 56:40.

56:57 - Fuel cell no. 3 shutdown.- Fuel cells 1 and 3 had been open circuited earlier because they were not putting out any power. With the cryogenic oxygen leaking at its present rate, there would be no reactants for the fuel cells within a short time. Because there was a possibility that the oxygen was leaking down stream of one of the fuel cell reactant valves, it was decided to shut off these valves in an effort to save the oxygen remaining in tank no. 1. Fuel cell 3 was selected because it had been the first of the two to fail.

57:03 - Main bus A power to thruster A-4.- The crew was told to put power to thruster A-4 by connecting to main bus A. The spacecraft had a positive pitch rate and the crew was unable to stop it with quad C thrusters. With A-4 activated, pitch control was regained.

57:18 - Fuel cell no. 1 shutdown.- Shutting down fuel cell 3 did not effect the oxygen leak rate, so the reactant valves to fuel cell 1 were closed in an effort to try to stop the leak.

57:22 - Charge battery A.- The crew was directed to charge battery A. The fuel cell 2 was maintaining main bus A voltage at an adequate level to support the battery charger. Mission Control decided to charge battery A

for as long as possible. Since the oxygen was still leaking, it was obvious that all fuel cell operation would be lost within about an hour.

57:29 - Disable power to quad C.- It appeared that quad C was not thrusting, although it was receiving firing signals. The explanation of this was that the propellant isolation valves had been closed by the "bang" at 55:55 and no propellant was being fed to the thrusters. Since these valves are powered by the main bus B, they could not be opened without getting power to this bus. The firing signals to quad C therefore were a useless drain of power on bus A, and the crew was directed to disconnect the thrusters from it.

57:39 - Fans on in oxygen tank no. 2.- In a final effort to try to increase the pressure in oxygen tank no. 2, the crew was directed to turn on the fans in that tank.

57:40 - LM power on.- The crew reported, "I've got LM power on."

57:49 - Stopped charging battery A.- In order to be ready to bring battery A on-line when fuel cell 2 failed, it was decided to terminate the charge. A total of about 0.75 amp-hours had been restored.

57:53 - CSM glycol pump off.- To reduce the main bus A loads, the crew was directed to turn off the glycol pump and to bypass the environmental control system radiators.

57:55 - Turn off oxygen tank no. 2 fans.- To further reduce the load on main bus A, the pumps in fuel cell 2 and the fans in oxygen tank no. 2 were turned off.

57:57 - LM data received.- Low-bit-rate telemetry data were received in the Mission Control Center at this time.

58:04 - Battery A on.- The crew powered main bus A with battery A in anticipation of the loss of fuel cell 2. The pressure in oxygen tank no. 1 was approximately 65 psi at this time.

58:07 - CSM communication reconfiguration.- The Command Module Pilot (CMP) was directed to turn off the CSM S-band primary power amplifier and to select low bit rate and down-voice backup. This was to reduce the load on battery A and maintain adequate circuit margins on the communication downlink.

58:18 - CSM guidance and navigation powerdown.- The CSM inertial platform (IMU) alignment had been transferred to the LM and verified by Mission Control. The crew was directed to turn off the CSM computer, the IMU, and the IMU heaters.

58:21 - Powerdown CM attitude control.- In an effort to reduce electrical power requirements in the CM, the CMP was directed to turn off "SCS Electronics Power," and "all Rotational Control Power Off." This completely removed all attitude control capability from the CM.

58:22 - LM RCS activation.- The LM crew was advised to pressurize the RCS, turn on the thruster heaters, and power up the attitude reference system.

58:27 - Activate "Direct" attitude control.- It was discovered that neither module was configured to provide attitude control. The quickest way to regain it was to have the CMP power up the rotational hand controller and the Direct coils.

58:36 - Fuel cell 2 shutdown.- The pressure of the oxygen being fed to this fuel cell had dropped below the operating level at 58:15 and it had stopped supplying current. As part of the CSM "safing," the fuel cell was disconnected from the bus and the reactant valves were closed.

58:40 - CSM powered down.- Battery A was disconnected from main bus A at this time, removing all power from the CSM.

Evaluation of Electrical and Cryogenic Oxygen Problems

The failure of fuel cell 3 resulted in the interruption of electrical power to several components in the spacecraft, including part of the telemetry signal conditioning. Main dc bus B was being powered only by fuel cell 3, so when its output dropped from about 25 amperes to less than 5 amperes, the bus voltage dropped from the normal 28 volts to less than 5 volts (fig. B5-2). Inverter no. 2, supplying power to ac bus 2, was being driven by main bus B and dropped off the line when the bus B voltage fell below about 16 volts. The bus failures, coupled with the cryogenic oxygen tank indications and some questionable instrumentation readings in fuel cells 1 and 3 (nitrogen and oxygen pressures), caused some initial uncertainty in the Mission Control Center.

The initial reaction was that there possibly had been a problem with major related instrumentation discrepancies. It was not clear that the telemetry quantities of cryogenic oxygen tank measurements or the fuel cell parameters were valid indications of conditions. For instance, the indication of no reactant flow and no fuel cell currents was compatible with fuel cells 1 and 3 having become disconnected from the main busses. Therefore, there was no reason to believe that they could not be reconnected. The lack of power output from the fuel cells could not be explained by the available information, i.e., the rapidity with which the fuel cells had failed. An additional factor that had to be considered

was that the high-gain antenna had unaccountably switched from narrow to wide beam width at about this same time. Some trouble had been experienced earlier in getting this antenna to "lock on" in narrow beam width, and the possibility of a short in the antenna electronics could not be ruled out.

The first direction given to the crew was at 56:00 to return the bus power configuration to the normal operating mode; that is, fuel cell 1 powering bus A and fuel cell 3 powering bus B. The primary purpose of this direction was to get the spacecraft in a known configuration and determine if the fuel cells could be reconnected to the main busses. There are no telemetry parameters which show which fuel cells are supplying power to which busses, but the flight controllers were of the opinion that some reconfiguration might have been done by the crew.

In operating with split busses, that is, with two fuel cells powering main bus A and one fuel cell powering main bus B, the amount of equipment tied to bus A represents approximately twice the load as that to bus B. When fuel cell 1 failed, fuel cell 2 had to take up the additional load on bus A. In doing so, the voltage dropped to about 25 volts, which is low enough to cause a caution and warning indication. There was no particular harm in the bus voltage being this low, but if it dropped any lower the performance of some of the telemetry equipment would be affected and the flight controllers and crew were concerned. Normal bus voltage is above 27 volts, and the master caution and warning indication is triggered at 26-1/4 volts or less. Had fuel cell 2 been tied to both main busses as on previous missions, the total spacecraft current of 73 amperes would have driven both busses as low as 21 volts. The crew put entry battery A on bus A at 56:03 to bring the bus voltage up. Mission Control concurred in this action.

In an effort to obtain more data for troubleshooting the situation, the crew was asked to read out the onboard indications of oxygen pressure and nitrogen pressure in fuel cells 3 and 1, respectively. At 56:08 the crew was requested to disconnect fuel cell 1. This fuel cell was not supplying any power, so to disconnect it should have no effect on the bus voltage, but there was a possibility that it might give some different indications in the fuel cell telemetry parameters. There was no change in the fuel cell parameters when it was disconnected and the onboard readouts of nitrogen and oxygen pressure were the same as those on the ground, which did not add to the understanding of the situation.

Efforts to sort out the various telemetry indications and crew reports continued for the next several minutes. The next direction given to the crew was to proceed with the emergency powerdown of the electrical system, using page EMER 1-5 of the CSM Emergency Checklist which is part of the Flight Data File carried in the CSM (ref. 7). It was important to reduce the electrical loads to a low enough value for the single operating fuel cell to be able to supply all the necessary power. Mission Control

was anxious to get entry battery A back off line to preserve as many amp-hours as possible.

The next step in the attempt to determine what was happening was to get power back to ac bus 2. Flight controllers considered powering ac bus 2 with inverter 3 driven from main bus A. Further consideration, however, led to the decision to simply tie ac bus 2 to inverter no. 1 which was already powering ac bus 1. Mission Control was interested in getting power to ac bus 2, since this is the only bus that powered the cryogenic oxygen tank no. 2 quantity and temperature telemetry. A temperature measurement was needed to confirm the zero pressure indication. The indications from oxygen tank no. 1 were that pressure and quantity were decreasing at a relatively high rate and it was imperative to immediately establish the condition of tank no. 2. It was not until after ac bus 2 had been powered up and oxygen tank no. 2 indicated empty, that the extreme seriousness of the situation was clear.

In proceeding through the emergency powerdown, the crew had placed the fuel cell pump switch to the "off" position in the one remaining good fuel cell; however, the pumps actually went off with loss of main bus B/ac bus 2 power. At 56:24, the Lunar Module Pilot (IMP) pointed this out to Mission Control, who in turn directed him to turn the pump back on. The only problem associated with leaving it off as much as an hour is that the fuel cell power output would start to degrade and no harm was done. But in the situation that existed, it is not inconceivable that had the crew not advised Mission Control of the fuel cell pump being off it would have been overlooked until a rise in the fuel cell 2 loop temperatures gave this indication.

Further direction in the management of the electrical system was not given until about 56:33. At this time the crew was directed to open circuit fuel cell 3 for the same reason as fuel cell 1 was open circuited earlier. At 56:35 the crew was requested to isolate the surge tank and at approximately this same time Mission Control also directed the crew to remove battery A from main bus A. The emergency powerdown had resulted in a load reduction such that the fuel cell alone could maintain bus voltage above 27 volts.

It had become apparent that the operation of fuel cells 1 and 3 probably could not be regained under any condition, and that with oxygen tank 1 quantity decreasing at its then present rate, the service module would soon become incapable of providing any life support or electrical power. The heaters and fans in this tank were turned on at 56:38 in an effort to increase the pressure, but to no avail. Because there was a possibility that a rupture had occurred in one of the inoperative fuel cells and the oxygen was leaking through it, Mission Control decided to shut down the cryogenic inputs to fuel cell 3 to see if this would stop

the leak, and the reactant valves to it were closed at 57:00. It should be pointed out that this is an irreversible step; once a fuel cell is shut down, it cannot be restarted in flight. Fuel cell 3 was shut down first since its internal oxygen pressure indication was zero; there was no change in the oxygen tank pressure decay rate, however, and the reactant valves to fuel cell 1 were closed at 57:18, with equally negative results. Mission Control made one last attempt to increase oxygen pressure by directing the crew to turn on the fans in tank no. 2. At about 57:22, the crew was directed to initiate charging of battery A. By this time it became clear, with the leaking oxygen tank no. 1, that fuel cell 2 could continue to operate only for a short period of time. Since the fuel cell was maintaining an adequate bus voltage and could provide the additional power to operate the battery charger, it was decided to charge battery A as long as possible. The charging of battery A was stopped after 22 minutes. At this time the oxygen tank no. 1 pressure had decayed to a point where continued operation of fuel cell 2 was questionable. Battery A was to be connected to main bus A at the first indication that the output of the fuel cell was decaying. Since the battery cannot be connected to power a bus while it is being charged, it was necessary to terminate the charging in anticipation of the fuel cell failure.

In preparation for using the entry battery to power main bus A, a further reduction of the loads on this bus was performed. The following equipment was turned off: glycol pump, oxygen tank no. 2 fans, and fuel cell no. 2 pumps.

The pressure in oxygen tank no. 1 was approximately 65 psi at 58:04 when the crew connected battery A to main bus A. This is below the minimum operating pressure for the fuel cell. This battery continued to power main bus A until about 58:40. By this time, the LM had been activated and the inertial platform alignment transferred from the command module.

The attempts to determine the cause of the problem in the electrical power system were confused by the misleading symptoms that resulted from the cryogenic tank failure. The failure in the electrical power system and cryogenic oxygen was so massive that by itself it would have created some initial confusion and made the flight controllers skeptical of the data, but in addition to fuel cell output dropping to zero and bus voltages dropping to zero, there were other indications that had to be considered. The attitude excursions (now presumed to have been caused by escaping oxygen) and the peculiar RCS thruster firings added to the confused situation. The RCS problems are discussed in more detail in the following section, but regardless of how quickly the problem in the electrical power system was resolved, there was nothing that could have been done to correct it. The only thing the crew and Mission Control could do under the circumstances was to preserve as much capability as possible for re-entry and to power down in an orderly manner to allow time for LM activation.

Maintenance of Attitude Control

Within 3 minutes after reporting the large bang, the Commander (CDR) reported some of the "talkback" indicators for the service module reaction control system (SMRCS) were showing "barberpole." His report indicated that the helium isolation valves to quads B and D were closed, and the secondary propellant fuel pressurization valves to quads A and C were closed (fig. B6-1). These valves have a history of inadvertant closure when the spacecraft is subjected to a large "jolt" in flight, such as the spacecraft separation from the S-IVB. This phenomenon was first encountered on Apollo 9. To reopen a valve that has closed in this manner, it is necessary to cycle the position selector switch to "close" and then back to the "open" position. All of the switches in this system have momentary "open" and "close" positions, and are springloaded to a center neutral position.

The valve position indicators in the spacecraft are the flag type which show gray when the valve is open and gray-and-white stripe ("barberpole") when closed; there is no telemetry indication of the valve position. Each valve and its respective indicator are powered from the same main dc bus and cannot be selected to the other bus. The valves in the propellant system for quads B and D are powered from main bus A and quads A and C are powered from main bus B. Therefore, there was no way to determine the status of the RCS propellant and pressurization systems of quads A and C, and there was no way to reposition the valves without powering up main bus B. The ability to open the isolation valves in quads B and D was not affected by the loss of main bus B.

Jet-firing signals, received at each individual thruster, open fuel and oxidizer valves by energizing a coil. There are two coils at each thruster. One, called "Auto," receives its signal from either the computer or the two rotational hand controllers (RHC's) and can be powered from either main dc bus, selected by the "Auto RCS Select" switches. There are 16 switches; one for each individual thruster that can be positioned to "off," "main A," or "main B." The other coil at the thruster is called "Direct" and receives its signal from the rotational hand controllers when they are rotated sufficiently far from the null detent. There are several ways of configuring the RHC's to power the Direct coils. Each RHC is limited as to which main bus and thruster combination it can be tied. Typically, the RHC's are powered so that half the jets are fired by main bus B and the other half by main bus A. As per normal procedure, the auto RCS select switches were configured so that single-jet authority in roll, pitch, and yaw attitude control would be available without reconfiguring if either main bus were lost. This protection can only be obtained if all four quads are functional. The loss of capability resulting from the failure of a main bus would be compounded by the concurrent closing of propellant isolation valves. Control about one or more axes would be lost

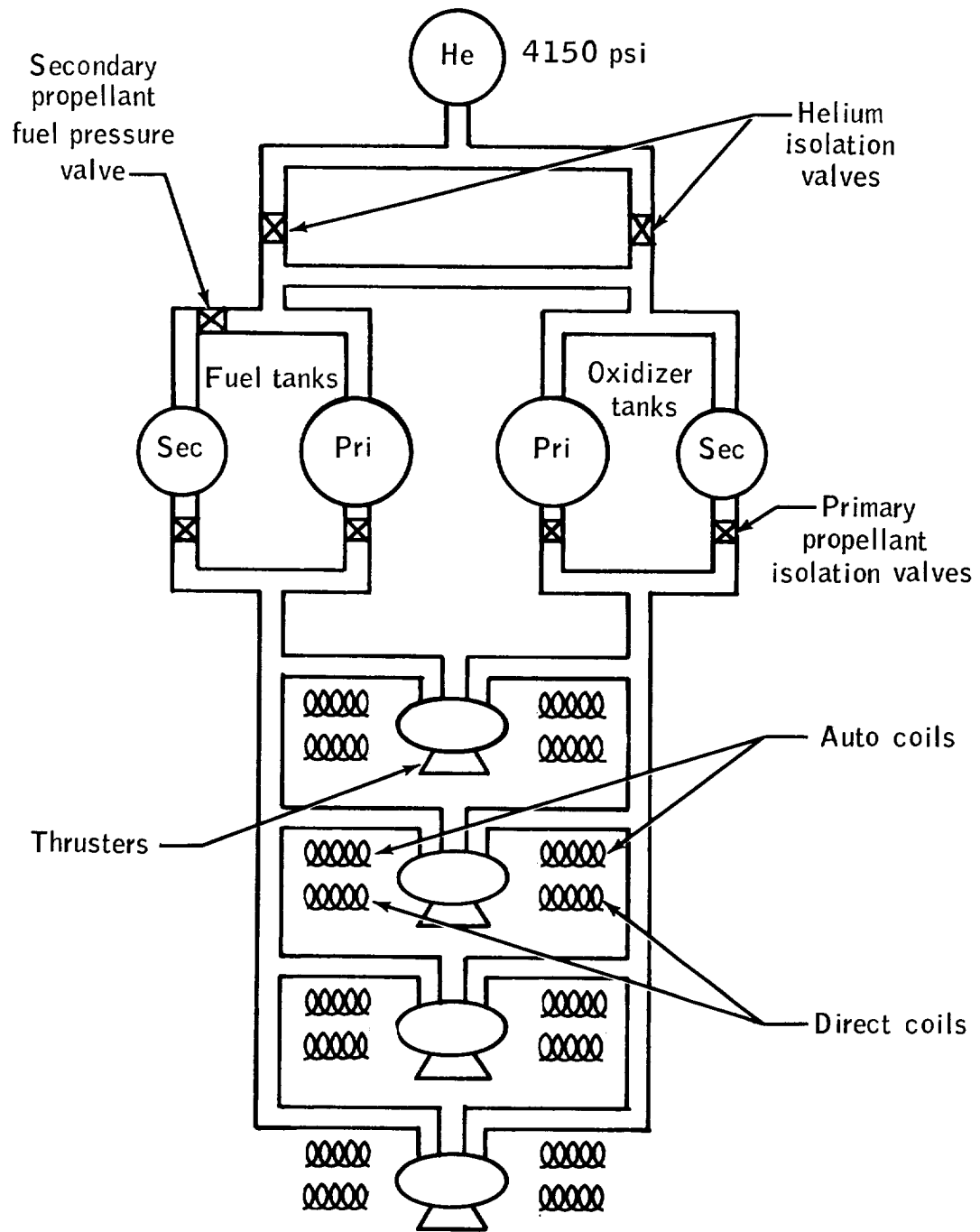

Figure B6-1.- Service module reaction control system one quad (typical of all four).

until some reconfiguration could be accomplished. Because power to the talkback indicators would also be lost, it would take some effort to determine the status of the control system.

At the time of the accident, the spacecraft was performing a computer-controlled roll maneuver and maintaining pitch and yaw attitude hold. The digital autopilot began firing RCS thrusters to counteract the attitude perturbations presumably caused by the oxygen tank no. 2 failure, and attitude was completely controlled until main bus B was lost. Soon after the loss of main bus B, Mission Control noted the spacecraft began to rotate about the pitch and yaw axes. It was also noted that the fuel and oxidizer pressures in quad D were decreasing and the crew was asked to verify that they had opened the helium isolation valves which had previously been reported as closed. Although the crew did not acknowledge this request, the pressures were observed to increase to the normal operating values shortly thereafter. The pressures had decreased in this quad because the helium pressurization valves had been jolted closed and subsequent firings of the thrusters had used some of the propellant. This increased the ullage volume and resulted in a noticeable decrease in tank pressures. The flight controllers correctly diagnosed the cause and were not misled into thinking the tanks were leaking.

At 56:07 Mission Control noted that the crew had turned off all Auto RCS Select switches, because they were concerned that unwanted thruster firings were causing the continuing spacecraft attitude excursions. At about 56:13 the spacecraft was observed to be approaching gimbal lock of the inertial platform. Gimbal lock is a condition in which the inertial platform loses its reference alignment. To prevent a gimbal lock, the spacecraft attitude relative to the inertial platform must be kept out of certain regions. Mission Control advised the crew of this situation, and in an effort to achieve positive control about all axes of the spacecraft, the crew was directed to reconfigure the RCS Auto Select switches for thrusters 3 and 4 in quad B and all thrusters in quad C to be powered from main bus A. This would provide single-jet control authority about each axis (fig. B6-2). The other jets were not switched to main bus A power in order not to drag down the main bus A voltage any more than necessary. The LMP acknowledged and the drift toward gimbal lock was arrested, although all rotations were not stopped.

At 56:22 the CMP reported that the spacecraft was being subjected to pitch and yaw rates and that he had to use direct control with the rotational hand controller to stop them. The rates would start to increase again as soon as he stopped the direct control. He asked if the ground could see any spurious jet firings that might be causing the rates. Although the data available in Mission Control were not complete (the position of the propellant system valves in quads A and C was unknown and firing signals to the Direct coils are not on telemetry), it appeared to the flight controllers that the jet firings were not causing the

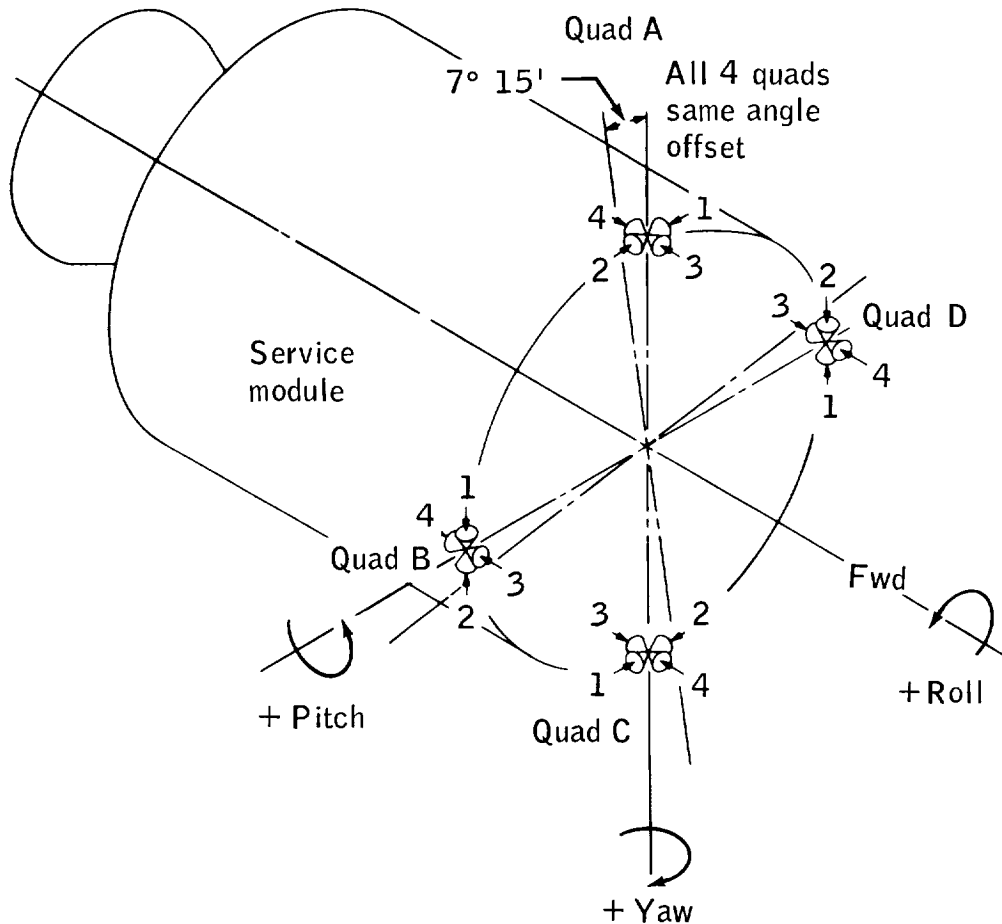

Axis	Direction	Thruster
Roll *	+	A-1, B-1, C-1, D-1
	-	A-2, B-2, C-2, D-2
Pitch	+	A-3, C-3
	-	A-4, C-4
Yaw	+	B-3, D-3
	-	B-4, D-4

* Autopilot can be configured to use quads B and D for roll or A and C.

Figure B6-2.- SM RCS quad location and thruster numbering system.

spurious rates. It was observed that thruster 3 in quad C was receiving firing signals almost continuously, but was having no success in stopping the negative pitch rate. In an effort to gain control over the negative pitch rate, at 56:32 Mission Control requested the crew to put the Auto RCS Select switch of thruster 3 of quad A on main bus A. It was suspected that C-3 thruster was not really firing because there was no perceptible reduction in quad C propellant.

At about 56:35 the crew was requested to remove all power from the quad B thrusters auto coils and to power all quad D thrusters from main bus A. This request was made in an effort to determine if quad B thrusters were causing the unwanted pitch and yaw rates. Mission Control continued to monitor the RCS thruster firings and the spacecraft attitude response, trying to determine the status of the system. During the next 10 minutes, the crew pointed out that the quad temperature indications for A and B were out of the normal operating range, and Mission Control assured the crew that they were within acceptable operating limits. In this same time period the ground had noticed numerous firing signals of thruster C-1. Since the flight controllers could see no explanation for this, the crew was requested to remove all power from the C-1 auto coil at 56:53. About 10 minutes later, the CMP reported no negative pitch capability, and requested clearance to enable thruster A-4. Mission Control responded immediately to "bring A-4 on," and the pitch rate was stopped within a few seconds. At 57:20, Mission Control noted a discrepancy in the roll control jet configuration. The autopilot was configured to use quads A and C for roll control, but the auto coils for these jets were turned off. The crew was directed to configure the autopilot to use quads B and D for roll control.

Based on a close observation of firing signals to quad C and the resulting spacecraft response, the flight controllers thought that the quad C propellant isolation valves had been jolted closed by the incident that caused the loud bang. The computer was still sending firing signals to the auto coils, but they were apparently having no effect and propellant was not being used by this quad. Therefore, to save the small amount of electrical power that was being spent by sending firing signals to the coils, at 57:29 Mission Control directed the crew to turn off the auto coils to this quad.

Complete attitude control appeared to be established at this time and all further attitude control support to the CSM was directed toward transferring control to the LM. The overall LM activation support is described in more detail in the following section; however, establishment of the attitude control of the LM is briefly summarized as follows:

1. Mission Control referred the crew to specific pages in the LM Activation Checklist (part of the Flight Data File, ref. 7) for the

procedure to transfer the inertial platform alignment from the CSM to the LM.

2. The CMP was directed to power down all of the guidance, navigation, and control systems after the LM platform had been properly aligned.

3. Mission Control assisted the LM crew in getting attitude control established by pointing out specific circuit breakers that needed to be closed and switches that needed to be positioned.

It was approximately 1-1/2 hours after the initial incident before complete automatic attitude control was established, although the crew had manual control capability at all times. The information on the ground was incomplete and was confused by the intermixing of automatic control and manual direct control. Furthermore, the major concern was the electrical and oxygen problems, and the only mandatory action in the control system area was to maintain a safe posture in the systems and avoid gimbal lock. These mandatory tasks were accomplished and in due time complete attitude control was established.

Lunar Module Activation

It was recognized at about 45 minutes after the accident that the LM might have to be used to provide the necessary life support, and the LM activation was started about 1-3/4 hours after the crew first reported the loud bang in the CSM. The first hour and 45 minutes were spent in regaining positive attitude control in the CSM, in troubleshooting the electrical problems in the CSM, and in attempting to halt the loss of oxygen from the service module. Since LM activation did not begin until the lifetime of the one functioning fuel cell was predicted to be about 15 minutes, there was a strong motivation to complete the LM activation and CSM powerdown as soon as possible.

The first order of business for LM activation was to get electrical power and the communications systems operating. A specific procedure for this was read to the LMP at 57:37. Although three checklists for LM activation were available as part of the Flight Data File in the spacecraft, Mission Control did not direct the crew to follow any of them. These checklists were designed for three different situations at LM activation. The first, entitled "Apollo XIII LM-7 Activation Checklist" (contained in ref. 7), contains the nominal mission sequences from initial LM manning to undocking prior to the lunar landing. The other two activation checklists are in the "LM Contingency Checklist" (contained in ref. 7). They were written to cover the situations of having to use the LM to perform an Earth-return abort maneuver for the docked CSM/LM configuration. One checklist includes activation of the primary guidance and navigation system (inertial platform alignment, etc.) and is called

the "2-Hour Activation List" because it was designed to be completed at a comfortable pace in time to execute a descent propulsion system maneuver in 2 hours elapsed time. The other contingency list is called the "30-Minute Activation List," and serves the same purpose, except that many steps, including the G&N activation, are omitted. There was no LM activation checklist available which was designed to cover the specific situation resulting from this incident. The features that were different are as follows:

1. The need to get the LM totally activated as soon as possible--including attitude control as well as supplying life support, communications, and electrical power.

2. The desire to power down the CSM as soon as possible in order to preserve all available battery power for reentry.

3. The LM was to serve as a "lifeboat" supplying oxygen, water, electrical power, and attitude control for 80 or 90 hours.

This presented a paradoxical situation in which almost total LM capability was required, but at the same time its consumables had to be conserved as much as possible. In responding to the situation, the flight controllers referred the crew to specific pages in the normal "LM Activation Checklist," augmented with additional instructions. The purpose was to bypass all steps that were not absolutely necessary for getting the LM power, communication, and environmental control system in operation. The total instructions given to the crew referred to only 4 pages of the 59 in the checklist. There were three single instruction additions to this shortly afterward which completed the LM configuration for supplying oxygen to the cabin. Although this particular contingency had never been simulated in the training exercises in preparation for the mission, similar cases had been considered, and Black Team personnel, including the Flight Director, Glynn Lunney, had prepared procedures and criteria for using the LM to augment the CSM. The simulations had been limited to cases where the LM ascent stage was to be retained following rendezvous in lunar orbit. These same personnel had participated in these simulations for the preceding missions of Apollo 10, 11, and 12, and therefore were familiar with the problems.

The next procedure given to the crew was designed to get the LM guidance and navigation system operating and to get the LM inertial platform aligned to a known reference. Again, Mission Control referred the crew to specific pages in the "LM Activation Checklist," along with certain necessary circuit breaker closures which were not listed on those pages. Although the necessary circuit-breaker panel configuration for LM activation is shown on two pages in the checklist, the crew was not referred to those pages by Mission Control. In order to save time, only

the necessary circuit breakers were given as part of each set of special instructions. The omission of a necessary circuit breaker closure later caused some delay in establishing LM attitude control.

Throughout this period of LM powerup, the CMP was given frequent instructions on the CM configuration to reduce power requirements. The crew completed an alignment of the LM IMU to the CSM IMU at 58:09. The platform gimbals angles for both spacecraft were read to the ground for computation of the fine-align torquing angles for the LM. As soon as the LM IMU was aligned, the CMP was directed to power down the CM computer and the IMU, including the IMU heaters.

At about 58:17 the temperature of the coolant loop in the LM began to rise and the LM crew was advised to activate the sublimator, referring to the appropriate page in the "LM Activation Checklist." During the next 2- to 3-minute period there was an unusually high density of conversation, both in the Mission Control Center and on the air-to-ground frequency between the CAPCOM and crewmen in both spacecraft modules. The CMP reported powering down the CM control system; the CDR reported he had no attitude reference system and requested permission to "close the FDAI circuit breakers so we could have a ball to see if we go to gimbal lock"; both the CMP and the LMP reported conditions and asked questions regarding configuration items; and on the ground the CSM flight controllers were trying to get their systems powered down as much as possible while the LM flight controllers were trying to "get through" to the LMP to pressurize the LM RCS and to turn the thruster heaters on.

At approximately 58:21, the CMP was told to continue his powerdown by turning off the power to the rotational hand controller almost simultaneously with the LM crew being directed to power up the FDAI and the RCS heaters, pressurize the RCS, and open the main shutoff valves. After about 5 minutes, when it became clear that neither spacecraft had control of the attitude, the CMP was directed to reactivate the CSM Direct attitude control capability. This was done and the LM crew then proceeded, following instructions from the ground, to pressurize the RCS and to perform the steps necessary to get the attitude reference system operating in the LM. Mission Control at 58:32 gave the LM crew the inputs for the onboard computer which set the proper system gains for the LM autopilot to control the docked spacecraft configuration. The LM achieved complete automatic attitude control capability at 58:34, when the crew received direction from Mission Control to close an essential circuit breaker that had been previously overlooked. The position of this circuit breaker is not indicated on telemetry, but the flight controller correctly diagnosed the problem when the crew stated they still did not have automatic control at 58:33.

After it was definitely established that the LM had attitude control, the CMP was given final instructions for completely powering down the CM,

and work toward getting the LM configured for the long trip home proceeded. Mission Control gave the crew the LM IMU torquing angles to get the platform fine aligned to the reference orientation. Discussions were held between the ground and the spacecraft concerning the ability of the crew to use the stars as a reference for platform realignment. It was concluded that this would be difficult if not impossible to do, and the current alignment should be preserved until after the abort maneuver.

An abnormally high pressure reading was noted in one of the LM ascent stage oxygen tanks shortly after telemetry data were received in Mission Control, and the crew was directed to use oxygen from this tank instead of the descent tank. Later it was diagnosed that the shutoff valve leaked, allowing the higher pressure oxygen from the manifold to leak into this ascent tank. The condition in itself was not a problem; the net effect was that this ascent tank was raised to a slightly higher than normal pressure which was well within the tank limits. This degraded the system redundancy, however, and had a subsequent leak developed in this tank, the LM oxygen supply would have been depleted (fig. B6-3).

The next phase of activity was devoted to reducing the power drain from the LM batteries to as low a value as practical. This included turning off many of the displays in the LM and put Mission Control in the position of monitoring system parameters for the crew. The crew was also given all the information required to execute a return-to-Earth abort maneuver 2 hours after passing the point of closest approach to the Moon (pericyynthion). Providing this data well in advance is a normal procedure which gives the crew the capability to perform the abort if communications are lost with the ground.

PLANS AND ACTIONS TAKEN TO RETURN THE CREW TO EARTH

After the crew had powered down the CM and activated the LM, the immediate situation had stabilized, and Mission Control could direct its full resources to the long-term problem of getting the crew safely home. The first item of concern was to determine an expected LM consumables lifetime and to develop a trajectory plan that would return the spacecraft to Earth within this lifetime. Also it was mandatory to reduce the expenditure of battery power and water as much as practical.

Subsequent efforts by Mission Control in support of the crew were varied and extensive. Much of this activity, however, is normally part of the routine functions of Mission Control. Such items as monitoring systems performance via telemetry parameters; keeping accurate records of consumables usage, and predicting future consumption rates; scheduling crew rest periods; and orbit determination are only some of the examples of this normal activity. However, only the special activities which were unique to this mission failure or which were of major importance to the

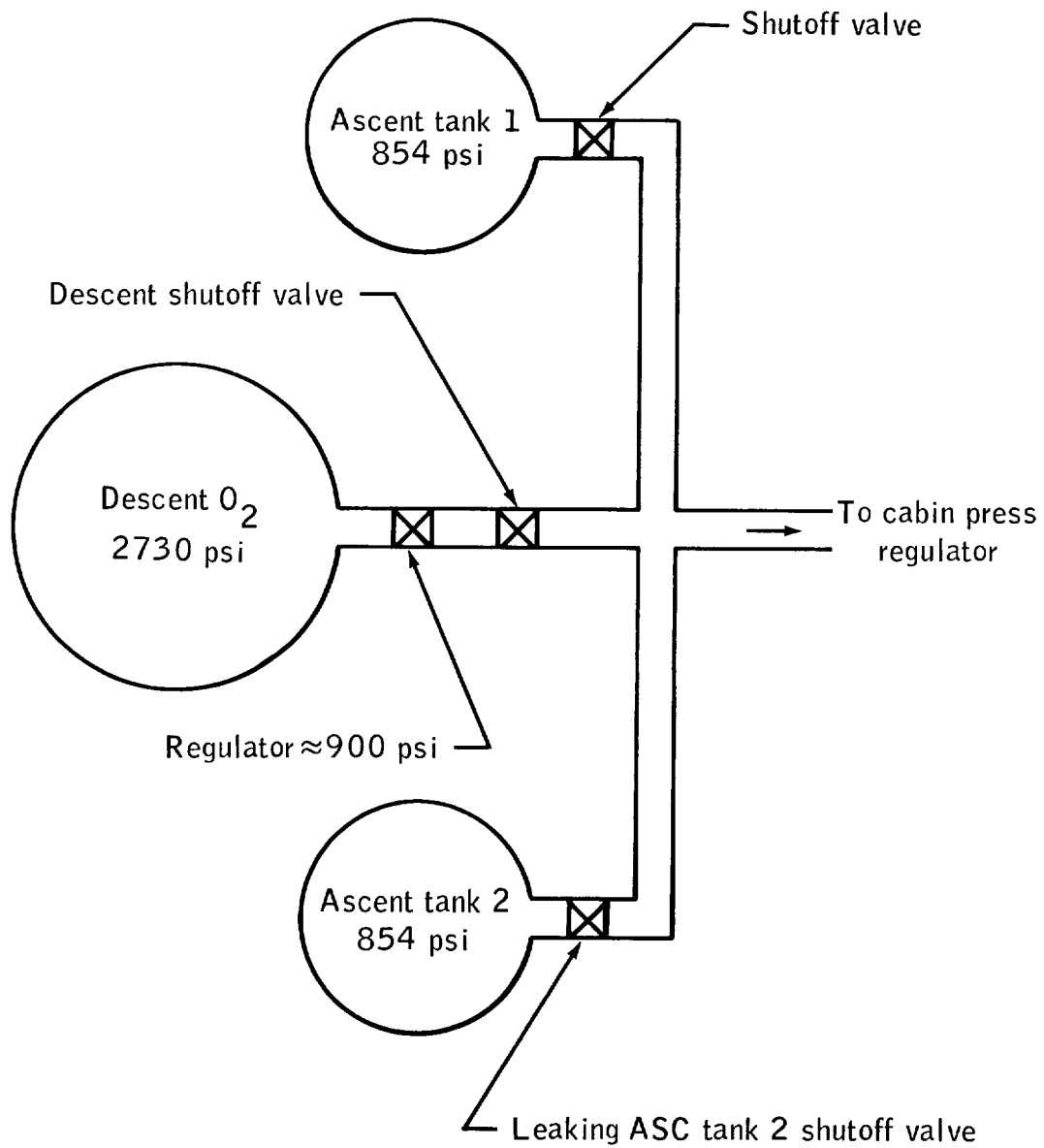

Figure B6-3.- Schematic of LM oxygen storage system.

successful return of the crew will be described. These activities are grouped in three categories in this report and described as independent subjects. These categories are consumables and system management, return-to-Earth trajectory control, and definition of procedures and checklists for reentry preparation. No attempt is made to describe the events chronologically. The Mission Operation Report (ref. 5) contains a comprehensive documentation of these events.

Consumables and Systems Management Actions

Consumables and systems management of both the LM and the CM were of vital importance and generated much activity in Mission Control.

Lunar module. -

Electrical power system: All LM electrical power is supplied by batteries. There are four in the descent stage with a total rated capacity of 1600 amp-hours and two in the ascent stage with a total rated capacity of 592 amp-hours. After the LM activation, analyses of power requirements and lifetime capability were completed. These analyses showed that after the abort maneuver at 61:30, the LM could be powered down to a total current requirement of about 27 amps and still keep the inertial platform aligned. This was extremely important because it made it possible to perform a guidance-controlled abort maneuver at 79:30 which could be used to reduce the return time back to Earth from 152 hours to 143 hours g.e.t. The analyses also indicated that if the guidance system was completely powered down after 79:30, the total power requirement could be reduced to about 17 amps, stretching the battery lifetime to approximately 165 hours g.e.t. This was a comfortable margin, even if the return time could not be reduced below 155 hours.

The flight controllers provided the crew with a list of specific switches to close and circuit breakers to open which would reduce the electrical load to the minimum possible consistent with safe operation. The fact that virtually all of the onboard displays were turned off is an indication of how extensively the spacecraft was powered down. Mission Control kept an accurate account of the switch and circuit breaker configuration, and was able to insure that the necessary equipment was powered up again when the subsequent trajectory maneuvers were made. The full powerdown configuration actually required only 12 amperes, instead of 17. The basis for this powerdown was contained in the LM Contingency Checklist (ref. 7). The Emergency Powerdown Checklist was developed for the case of the LM in lunar orbit awaiting rescue by the CSM. Some additions to this listing of turned-off equipment were made by Mission Control.

As soon as the electrical power system configuration was established and apparently performing well, Mission Control began planning for what actions to take if a LM battery failure were to occur. These plans

included listing the few remaining items of equipment which could be taken off line in the powered-down condition. Since the current was already down to less than 17 amperes, there was not much left that could be removed except the communications equipment, but certain equipment could have been operated on a periodic basis rather than continuously. A schedule for this kind of operation was planned in case it became necessary.

At 97:14:26 the IMP called Mission Control to report an anomaly that he had observed in the LM. This anomaly was a "little thump" that was heard but not felt, and it seemed to come from the vicinity of the LM descent stage. The IMP also observed a "new shower of snowflakes come up that looked like they were emitted from down that way." The venting appeared to be going radially outward, perpendicular to the X-axis in the +Y, +Z quadrant, and it continued for approximately 2 minutes. Neither the flight controllers nor the LMP observed any anomalous behavior in the data. The LMP closed the essential display circuit breakers in order to scan his instruments. The flight controllers searched the various displays of telemetry data. Since no unusual readings were noted, the investigation of the "thump" incident was not pursued further at that time. A postflight review of the data indicates that at about the time of the "thump," a large, momentary increase in LM battery output occurred. The surge was of 2 to 3 seconds duration, and was experienced by all four descent batteries. The behavior of the four battery currents is summarized in the table:

Battery	Current output, amps		
	Before surge	Peak	After surge
1	3	37.5	3
2	2	Off-scale high 60 amps	6
3	3	36.8	1
4	3	30.5	1

The MSC investigation of this anomaly is still in progress, and the exact cause of the current increase, the "thump," and the venting is not known. It does appear that they were all related, but not connected with the previous service module failure.

At 99:51 g.e.t. a descent battery no. 2 malfunction warning light illuminated. Because the display system on board was powered down except for the caution and warning panels, the analysis of the problem was done

in Mission Control where telemetry was available. There were three possible valid causes of the warning light: an overcurrent, a reverse current, or a battery overtemperature condition. The troubleshooting systematically eliminated all three, and Mission Control concluded the problem was a faulty temperature sensor. The crew was advised to reconnect the battery about an hour later. No problems with the battery ever developed, but the sensor indication later became erratic, causing several MC&W alarms. A plot of total usable amp-hours remaining in the LM batteries is contained in figure B6-4.

Coolant system: It was as essential to power down the LM as much as possible in order to reduce the cooling requirements as it was to reduce the battery amp-hours expended. The LM coolant loop uses the action of ice sublimation to take heat away from the spacecraft. Feed water for the sublimator is stored in tanks, and the rate of water usage to provide this cooling is proportional to the amount of electrical power expended because of the heat generated. The analysis showed that for the above-mentioned electrical power requirements, the LM water supply was most critical and would be depleted about 155 hours g.e.t. This analysis was based on data obtained several hours after the initial LM activation. Estimates based on the usage rate immediately after activation indicated the LM would be depleted of water by 94 hours g.e.t. As expected, the rate reduced drastically, however, after the initial cooling down was accomplished.

During the mission period before the postpericyynthion abort, when the spacecraft was on a trajectory with a 155-hour g.e.t. landing time, efforts were made to find a method of increasing the LM water margin by means other than a further powerdown. Two procedures were developed as a result of this effort. The first allowed the crew to get drinking water from the CM potable water tank, and the second was a method of transferring water to the LM tanks for use in the LM coolant loop. The latter procedure involved the use of the portable life support systems (PLSS) water tanks as an intermediate container for transporting the water from the CM waste tank. Although it did not become necessary to use the second procedure, it was tested on the ground by engineering personnel at MSC, and was available in Mission Control. A plot of the usable water remaining in the LM is shown in figure B6-5.

Oxygen supply and carbon dioxide removal: The oxygen supply in the LM was adequate for more than 200 hours g.e.t., and was of no concern (fig. B6-6). This included a supply in the systems normally used for the lunar extravehicular activity (EVA). The initial problem with the ascent oxygen tank 2 had stabilized to the condition that the pressure in the tank was about 100 psi above the normal operating range. Engineering support personnel had advised Mission Control that this was no problem, and no further actions were taken in this area.

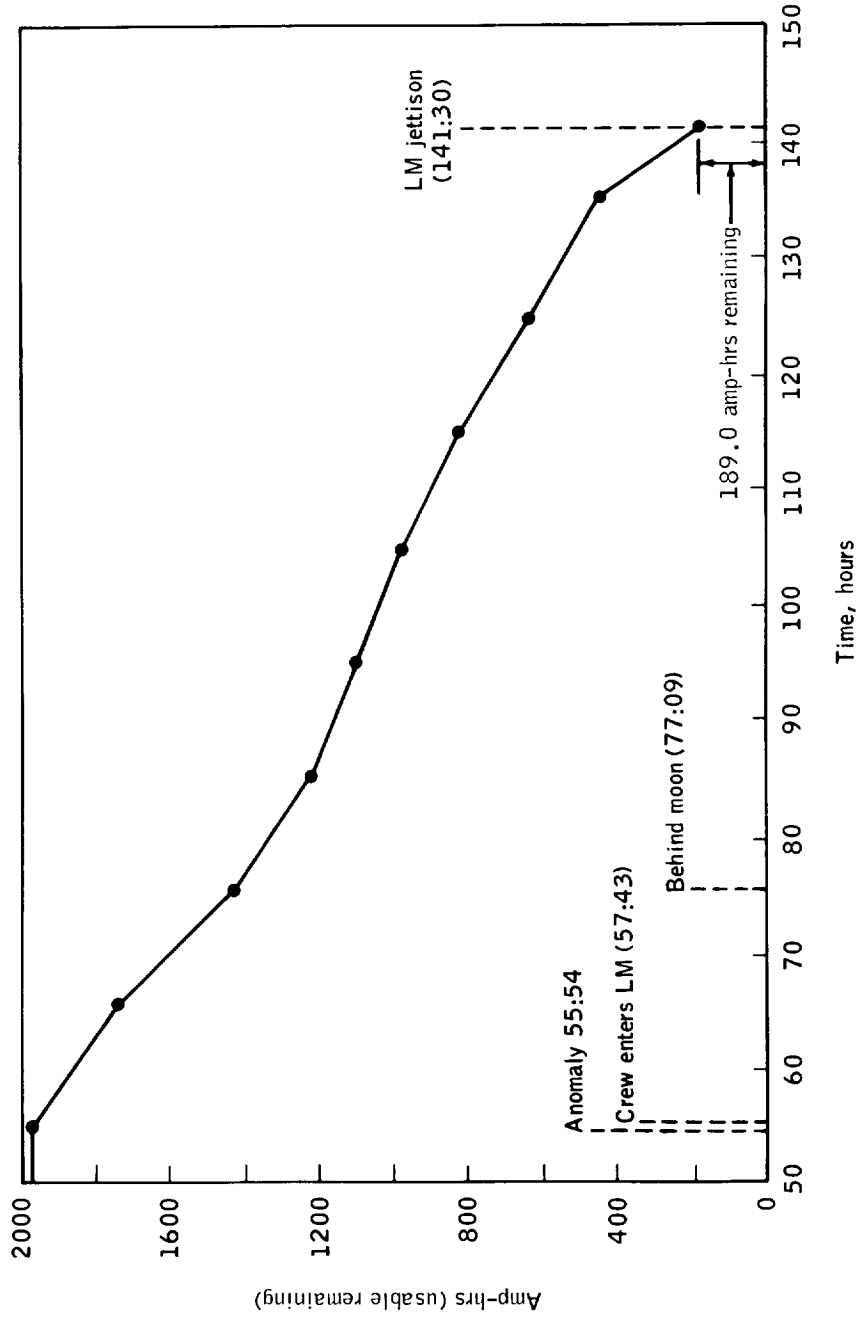

Figure B6-4.- Electrical power system consumables status.

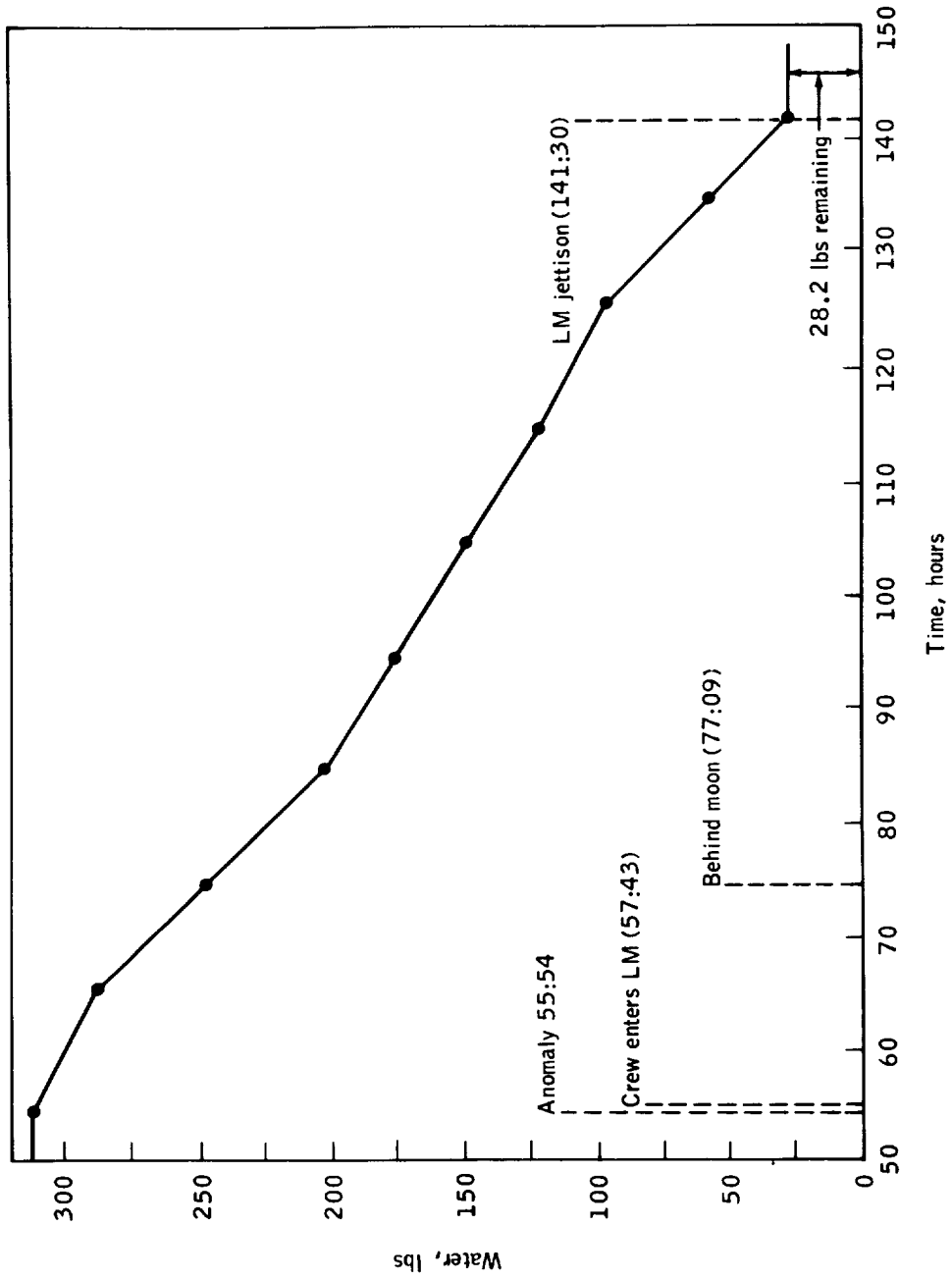

Figure B6-5.- Usable remaining water.

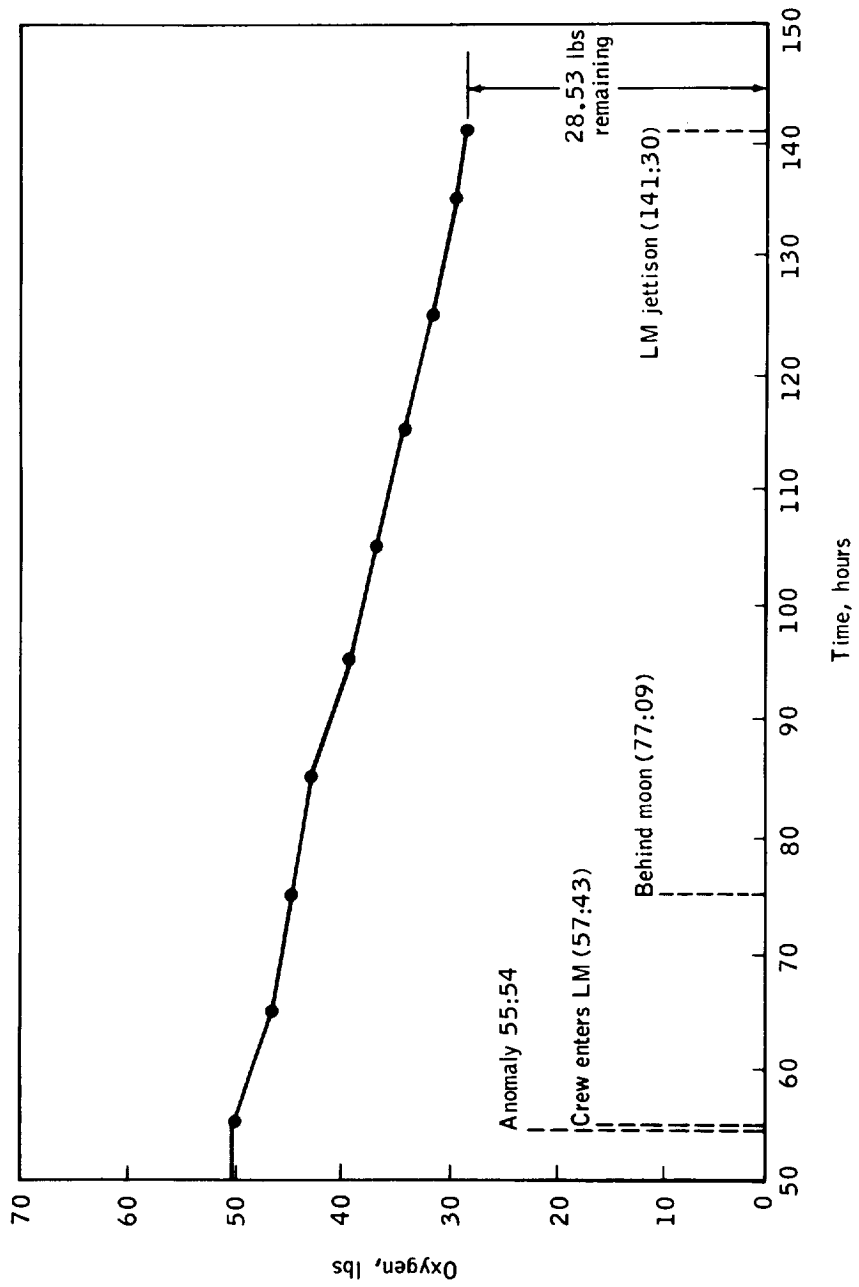

Figure B6-6.- Usable remaining oxygen.

The problem of removing carbon dioxide from the cabin oxygen was a serious one. The LM, like the CSM, uses lithium hydroxide (LiOH) cartridges to scrub the recirculated oxygen to remove odors and carbon dioxide. The LiOH cartridges are rated for a specified total man-hours capacity, and eventually must be replaced when they become saturated. The LM cartridges were not adequate for carbon dioxide removal for three men for the duration of the Earth-return trip. There were more than adequate cartridges in the CM, but they would not fit in the LM canisters. There were several methods suggested for solving the problem, including powering up the CM system to circulate cabin oxygen through its LiOH canisters. The method that was actually used was developed by Crew Systems Division personnel at MSC. It consisted of using tape, flight data file cards, and plastic bag material to connect the CM LiOH canisters to the LM oxygen circulation system. The crew implemented the modification and it worked very well. The partial pressure of carbon dioxide reading indicated by the onboard gage dropped rapidly from 8mm Hg to 0.1mm Hg soon after the rig was completed at 94 hours g.e.t. The modification was not tried until this time in order to get maximum use from the LM cartridges. About 20 hours later, the carbon dioxide partial pressure reading had increased to 1.8mm Hg, and a procedure for putting two additional cartridges in series to those in the CM canisters was given to the crew. This procedure was also developed by engineers at MSC (fig. B6-7). After this second modification was completed, the carbon dioxide partial pressure remained below 2mm Hg for the rest of the mission, without any further modifications necessary.

The modifications to the oxygen circulation systems were evaluated in the simulators at MSC before they were accepted by mission operations personnel. This included tests in the pressure chamber. As mentioned earlier, there were other methods that could have been adopted had this one proved to be unacceptable.

Reaction control system: The LM reaction control system (LMRCS) propellants were another consumable that had to be managed carefully. Maintaining attitude control of both the CSM and the LM, with a total weight in excess of 90,000 pounds, can be done by the LMRCS, but is a particularly taxing job. The LM control system was not designed to perform this task, and does not do it efficiently in terms of propellant expenditure. This was aggravated by the fact that there is some control moment loss and some cross coupling when the LM is in control due to thrust plume deflectors designed to protect the LM descent stage from extended thruster firings.

Shortly after the LM assumed attitude control, Mission Control gave the crew a procedure which increased the attitude excursion tolerance in the computer. This increased the attitude error tolerance and caused



Figure B6-7.- View of CM LiOH cannister modification as installed in the IM.

less thruster firings to be commanded by the computer which was maintaining automatic attitude control. The simulators at KSC and MSC were used to evaluate different techniques for maneuvering the spacecraft under manual control as well as automatic. Manual maneuvers became necessary after the LM inertial platform and computer were powered down after the post-pericynthion abort maneuver. Backup and support crews performed the evaluations and recommended certain techniques.

Mission Control kept a close watch on the RCS propellant consumption and was prepared to have the crew revert to an uncontrolled, drifting flight mode if necessary. This would have been requested if the RCS propellant decreased below the "red line" value. The flight controllers had computed a "red line" which provided enough propellant for meeting the midcourse correction maneuver requirements and the requirements to maneuver in preparation for the reentry sequence.

Command service module.- After the CM powerdown at 58:40 there was very little system management that could be or needed to be done. The electrical power system, however, did require some attention. The first action was to get the CM into a known configuration. So much had happened so quickly during the period following the accident, that neither the crew nor Mission Control had a complete knowledge of the switch configuration in the CM. Therefore, a checklist was developed which listed the desired position of every switch, circuit breaker, and actuator handle in the spacecraft. The lift-off configuration in the CSM launch checklist portion of the Flight Data File served as the baseline for this list, and the modifications were read to the crew. The crew then configured the CM as defined by this list.

The next task was to determine the status of main dc bus B. Because power had not been applied to the bus since the failure of fuel cell 3 at 55:58, it was not certain that a major short did not exist on it. Mission Control defined a procedure which used entry battery B to apply power to the bus. The procedure contained 12 steps, and the displays the crew should monitor were defined, along with the expected indications. The baseline configuration described in the preceding paragraph insured that all loads were isolated from the bus. The procedure was implemented at 94:21 hours and verified that there were no shorts on the bus.

After the CM had been powered down for about 24 hours, it began to cool down to a temperature well below the minimum expected operating temperatures. Engineering support personnel became concerned about the motor switches which are normally used to connect the battery busses to the main dc busses. When it was realized that the CM was going to get unusually cold before the initiation of the entry sequence, the ability of the batteries to provide sufficient potential to drive these switches

was questioned. The analysis of the situation was difficult because of the uncertainty as to how cold the battery compartment would get, and it could not be proven that a problem would exist. However, to circumvent the situation, it was decided to close the bus tie motor switches after the main bus B checkout. Subsequently, the appropriate circuit breakers would have to be used as switches to connect and disconnect the batteries from the busses (fig. B6-8). A step-by-step procedure was defined and read to the crew and the bus tie switches were closed at 94:21 g.e.t.

A procedure was also developed for charging the CM entry batteries with the LM electrical power system. Approximately 20 amp-hours of the 40 amp-hours capacity had been used from entry battery A during the period immediately following the accident; a much smaller amount had been taken from battery B since that time. Since the LM battery capacity provided a comfortable power margin for the return to Earth, Mission Control decided to invest some of that power in charging the CM batteries. Preliminary examinations of an entry preparation sequence indicated that in order to not rush the crew, the CM powerup should be initiated about 6 hours before entry. To do this demanded that all three CM batteries be fully charged. The procedure to charge the CM batteries was defined in complete detail by Mission Control. In its most basic terms, it was simply a procedure that used the LM/CM electrical umbilical to get power to the CM main bus B. Then the CM battery charger was tied to this bus and the battery to be charged. The procedure as read to the crew consisted of four typewritten pages of notes and a step-by-step switch position definition. The battery charging was initiated at about 112 hours g.e.t. to demonstrate that it could be done and was completed at 128 hours after 18 of the 20 amp-hours had been replaced. This was done well before the reentry preparation, to allow the entry planning to proceed with the assurance that all batteries would be fully charged at the beginning of the entry preparations.

Return to Earth Trajectory Control

All trajectory determination and maneuver targeting for getting the crew back to Earth was performed by the Mission Control Center. This is the normal procedure, but usually the crew also has the capability to do this. This serves as a backup in case communications are lost with the ground. However, with the command module G&N system completely shut down, the crew was totally dependent on Mission Control for navigation, and abort and midcourse correction maneuver targeting. There was no backup.

There were four trajectory change maneuvers performed to return the spacecraft to the recovery area in the mid-Pacific Ocean following the command module powerdown (fig. B6-9). The first, performed at 61:30 g.e.t., placed the spacecraft on a safe reentry trajectory. The second, performed at 79:28 g.e.t., adjusted the Earth landing point to

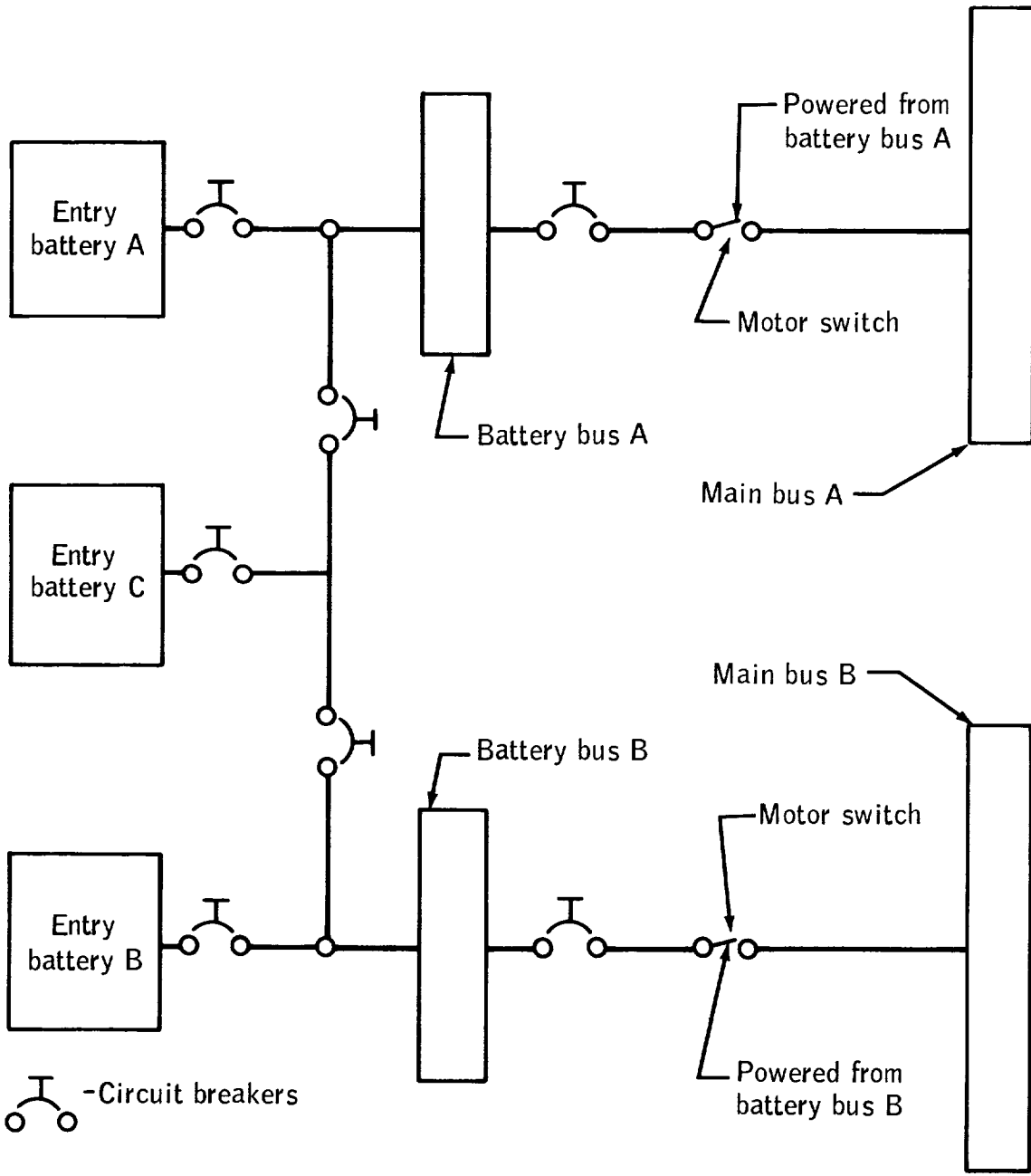

Figure B6-8.- Simplified wiring diagram showing battery power to main busses.

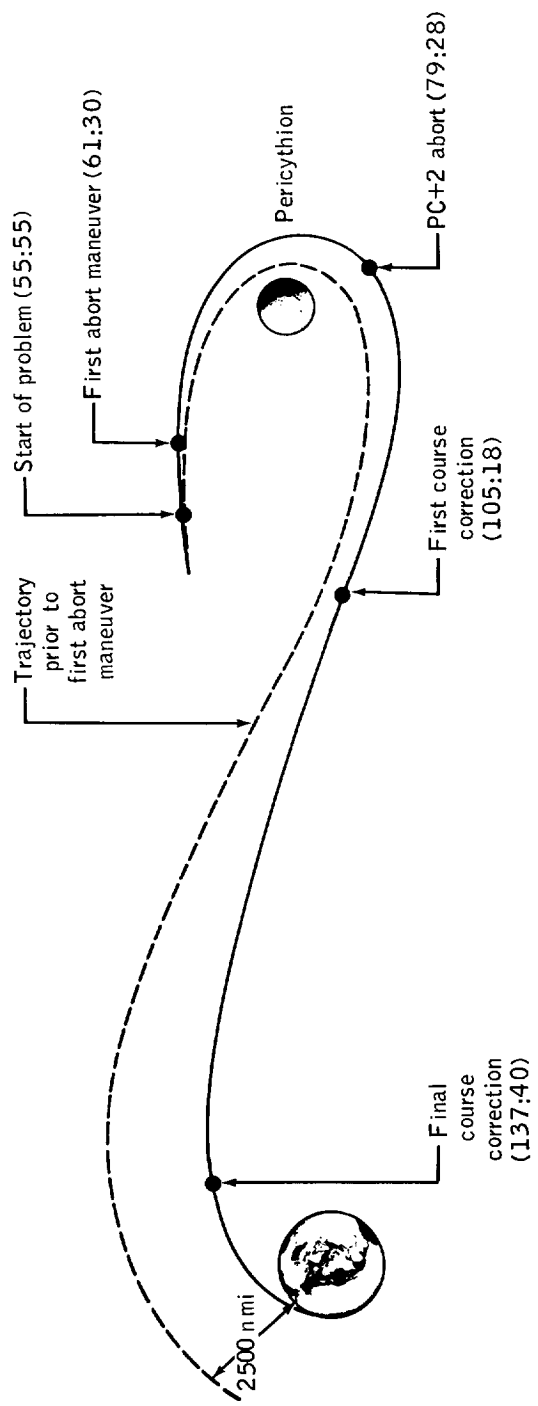

Figure B6-9.- Return-to-Earth trajectory control.

the mid-Pacific recovery area. The last two maneuvers, performed at 105:18 and at 137:40 g.e.t., were course corrections which adjusted the entry conditions to be in the middle of the safe entry corridor. These maneuvers and the decisions related to the choice of specific course changes are described in the following paragraphs.

Abort maneuver at 61:30 hours.- Soon after the failure in the CSM it became obvious that the lunar landing mission could not be achieved and that all effort would have to be focused on getting the crew back to Earth as soon as possible. At the time, the spacecraft was not on a trajectory that would return to a safe reentry of the Earth's atmosphere --so a trajectory change was mandatory. The following questions needed to be answered: What path should be followed back to Earth? When should the trajectory-changing maneuver be executed?

Because the spacecraft was on its way to the Moon, there were two basic types of abort paths that could have been followed: (1) a direct abort in which the trajectory would be turned around and the spacecraft returned to Earth without circumnavigating the Moon; and (2) a circumlunar abort in which the spacecraft would follow a path around the Moon before it returned to Earth. The disadvantage of the circumlunar abort path is that the flight back to Earth takes a longer time than for direct aborts. However, circumlunar aborts require much less velocity change and consequently much less propellant to perform, and part of the flight time can be made up by executing an additional "speedup" maneuver after the spacecraft has passed the Moon.

The direct abort was ruled out for Apollo 13 because the propellant requirements were so large. It would have been necessary to jettison the LM in order to reduce the spacecraft weight so that the service propulsion system (SPS) engine could make the necessary velocity change. The LM was essential to the crew's survival, and must not be jettisoned. Therefore, the choice was narrowed to the circumlunar abort which could be executed with the LM descent propulsion system (DPS), but there were still some decisions to be made. The options were as follows:

1. Do nothing until after the spacecraft passed the Moon; then execute a maneuver to place it on an Earth-return trajectory.
2. Execute a maneuver as soon as practical to place the spacecraft on an Earth-return trajectory and power down the LM immediately thereafter.
3. The combination of both the above: Get on an Earth-return trajectory as soon as practical, and after the spacecraft passed the Moon, perform a maneuver to speed up the return to Earth.

Option 2 was selected. The principal reason was that the LM systems necessary for executing the maneuver were working at the time, and they might not be working 20 hours from then when the spacecraft was in position to do option 1. Another consideration was the fact that the velocity requirement to get on an Earth-return trajectory would increase from 40 fps to 160 fps, making it impossible to perform with the RCS system if this became necessary. So even though option 1 would have allowed an immediate partial LM powerdown, saving some electrical power and water, it was decided that the risk was not worth the savings. Also, option 2 left option 3 available if the guidance and navigation system could be powered up to perform the second maneuver.

The decision having been made to perform a circumlunar abort, and to perform as soon as possible the maneuver to place the spacecraft on a safe reentry trajectory, the only question remaining open was what Earth landing point to target for. Because of the LM consumables status, getting back to Earth as soon as possible was the overriding factor. The quickest return resulted in a landing in the Indian Ocean at 152 hours g.e.t. This meant giving up the ability to bring the spacecraft down in the vicinity of the prime recovery force in the Pacific, although at least a water landing was provided. This was considered to be acceptable because the abort maneuver after passing the Moon probably could be used to decrease the flight time and to land in the prime recovery area.

Post-pericyynthion abort maneuver.- Although the spacecraft was placed on a reentry trajectory by the abort maneuver at 61:30 with a landing at 152 hours g.e.t. in the Indian Ocean, it was decided that a post-pericyynthion abort maneuver (PC + 2) should be performed. There were two reasons: (1) to reduce the return time to increase the LM consumable margin (the prediction at the time indicated only a 3-hour margin); and (2) to change the landing point to the mid-Pacific where the recovery force could be on station.

During the first few hours after LM activation, detailed analysis of LM consumable usage had shown that the guidance and navigation system could be kept powered up until after the PC + 2 abort maneuver at 79:30 g.e.t. It was predicted that all consumables would last at least until 155 hours g.e.t. even if the LM powerdown to 15 amperes total current were delayed until after 80 hours g.e.t.

There were several options available for decreasing the flight time, but only the three listed in the following table provided a landing in the mid-Pacific.

Option	Delta V, fps	Engine used	Landing time, hours g.e.t.
1	850	DPS	142
2	4000	DPS	118
3	4000	SPS	118

Option 1 was selected even though it resulted in the longest flight time, because of some very undesirable characteristics of options 2 and 3. The problem with option 2 was that it would be necessary to jettison the service module in order to be able to get a 4000 fps velocity change with the LM descent propulsion system. Such a maneuver would almost deplete the descent propellant, leaving a very limited capability should subsequent maneuvers be necessary. There was a high probability that a large course correction would have to be made later. Option 2 was seriously considered, but eventually rejected because it left the CM heat shield exposed to the space environment for such a long period of time, and the possible thermal degradation that might result from this was an unknown risk. The heatshield capability to withstand reentry might be compromised by the prolonged period of cold temperature it would experience. Option 3 was rejected because of the unknown status of the SPS; it was thought that the SPS or the SM might have been damaged by whatever had caused the "bang" and that the SPS should not be used unless absolutely necessary.

Since option 1 provided a comfortable consumables margin and allowed retention of the service module, it was selected. Option 1 also allowed a descent propulsion system delta V capability of approximately 1000 fps to be retained after the abort maneuver.

Part of the preparation for each mission is the establishment of "ground rules" and maneuver monitoring criteria for each planned maneuver. The "ground rules" are general statements which define what should be done if certain events occur. The maneuver monitoring criteria define explicitly the conditions under which the crew will deliberately terminate the maneuver early. The criteria are not the same for all maneuvers because there is a wide variation in the seriousness of the effect of dispersions, and in the seriousness of the effects of early or late engine shutdown. The trajectory and mission situations for the post-pericynthion abort burn were different from any of those for which criteria had been defined; therefore, it was necessary to establish these "rules."

The pertinent characteristics that would affect the rules were as follows:

(a) The spacecraft was on a safe reentry trajectory, although small course corrections probably would be required before reentry.

(b) The primary purpose of the maneuver was to place the landing point in the vicinity of the recovery force.

(c) The secondary purpose of decreasing the flight time was of major importance.

(d) The LM inertial platform had not been fine aligned for approximately 20 hours.

(e) The maneuver could be delayed for 2 hours with an increase in delta V of only 24 fps.

(f) The LM descent propulsion system was to be used.

The following ground rules based on these characteristics were established by the Mission Control team and were given to the crew:

(a) If the engine does not light, do not attempt any emergency start procedures.

(b) If the primary guidance and navigation system (PGNS) has failed, do not perform the maneuver.

(c) Do not attempt to null the indicated velocity errors after engine shutdown.

(d) If an engine shutdown occurred, a subsequent midcourse correction would be performed no sooner than 2 hours later.

The criteria for early termination of the maneuver were defined as follows:

1. Propulsion System Parameters

- (a) Engine chamber pressure ≤ 85 psi (TM)
 ≤ 77 percent thrust (on board)
- (b) Inlet pressure ≤ 150 psi (TM)
 ≤ 160 psi (on board)
- (c) Delta P fuel/oxidizer > 25 psi (ground monitored)

2. Guidance and Control System Parameters

- (a) Attitude rate >10 deg/sec (except during start transient)
- (b) Attitude error >10 degrees
- (c) Engine gimbal light
- (d) Inertial platform failure with a program alarm
- (e) Computer warning light
- (f) Control electronics system dc fail light

A final rule that was defined stated that if an early engine shutdown was experienced not due to any of the above, a relight should be attempted, using the engine-start pushbutton and the Descent Engine Command Override switch.

A contingency LM activation checklist had been defined prior to the mission and was part of the crew's Flight Data File. This checklist was designed to prepare the LM for a docked descent propulsion system burn from a completely dormant state. The majority of this checklist had been accomplished with the initial LM powerup at 58 hours g.e.t. The flight controllers reviewed the list in detail and defined a modified list of steps necessary to prepare the LM for the abort maneuver. The modification was basically a deletion of steps already accomplished or not necessary; however, there was one change which revised the time at which the helium regulator shutoff valve was to be closed. This was done to preclude the possibility of a shift in the regulator operating pressure causing a freezing of the propellant lines after this burn. Such an event would prevent further use of the descent engine and it was mandatory to maintain this engine for probable subsequent trajectory changes.

Midcourse correction maneuver.- Postmaneuver tracking data indicated that the second abort maneuver had placed the spacecraft grossly on the right path. However, because the LM inertial platform could not be fine aligned prior to the maneuver, the execution errors were larger than normal and the spacecraft was not on a safe reentry trajectory. This was expected and subsequent corrections were planned for in the LM consumables budget. The correction delta V magnitude was projected to be about 7 fps if executed at 104 hours g.e.t. Unlike the abort maneuver, the course correction maneuvers are not extremely sensitive to pointing accuracy, and with the delta V of only 7 fps it could probably be executed with sufficient accuracy without the inertial guidance system. A special

team, composed of off-duty flight controllers and members of the backup flightcrew, was formed to define the maneuver ground rules and procedures to be followed for the course correction maneuver. A detailed crew checklist was to be developed also. None of the procedures or checklists in the Flight Data File were applicable because of the unique situation that existed for this case.

The major issues addressed by this team were as follows:

1. How to get the spacecraft aligned in the proper direction for the maneuver? Was it necessary to power up the inertial platform?
2. Which engine should be used, descent propulsion system or LM RCS?
3. What burn monitoring criteria should be used?
4. What attitude control modes should be used?

The team determined that it was unnecessary to use the inertial platform for the maneuver. The spacecraft could be oriented in the proper pitch direction by sighting on the center of the Earth with the Crew Optical Alignment System (COAS) fixed along the LM +Z axis. The approximately correct azimuth could be achieved by aligning the sunset terminator parallel to the LM Y-axis. This procedure had been developed in the preparation for Apollo 8 when it was discovered that course correction maneuvers could best be made in a local horizontal attitude (that is, perpendicular to a vector from the center of the Earth to the spacecraft). It could easily be applied to the LM-active maneuver, and would give adequate thrust pointing accuracy, so it was not necessary to power up the LM G&N system and try to align its inertial platform.

It was decided to use the descent propulsion system for the maneuver instead of the RCS engines, because the engine-on time for an RCS maneuver would exceed a constraint which protects the LM RCS plume deflectors. The engine was to be left at the low throttle point (about 12.6 percent of full thrust) to give the crew more time to monitor the burn and the lower acceleration should increase the shutdown accuracy. The engine shutdown criteria were the same as for the previous burn. It was decided to monitor the delta V with the backup guidance system accelerometers, but to shut the engine down at a fixed delta time specified by Mission Control. Studies had shown that the burn time computed by Mission Control was very accurate. Since the accelerometers had not been maintained at their proper temperature (heaters had been turned off to reduce consumables expenditure), their status was questionable and the team decided to not use the backup guidance system as an engine shutdown cue. However, if this system appeared to perform nominally

during the maneuver, it would be used to null the velocity residuals in the X direction. Velocity errors in either Y or Z direction had an insignificant effect on the entry conditions and were not to be nulled.

Attitude control of the docked vehicle with the backup system required both the CDR and the LMP to actively participate, and Y- and Z-axis translation thrusters had to be used to get adequate control torque. The team defined the modes and procedures to be used in getting the spacecraft in the correct attitude and in controlling the attitude during the engine burn. A procedure to return the spacecraft to the passive thermal control condition was also defined.

All plans were completed after two lengthy sessions. A subgroup from the team defined a detailed crew checklist to be followed in preparing for the maneuver and in preparing for the coasting flight following the maneuver. The checklist was evaluated by members of the backup crew in mission simulators at MSC and some minor modifications were made as a result. The checklist and the procedures were reviewed by the on-duty Mission Control team and then read to the crew approximately 5 hours prior to the scheduled course correction. This allowed the crew ample time to study them and to rehearse their roles.

Entry Procedures and Checklist Definition

After the situation in the spacecraft was stabilized, one of the several parallel activities that was initiated was the definition of procedures for the pre-reentry phase. The total loss of electrical power in the service module forced some major revisions to the activities and the crew procedures for this part of the mission. The most significant consequences of this loss were the following: (1) SM RCS engines would not continue to fire to separate it from the CM after jettison; and (2) LM electrical power and RCS should be used to conserve the CM batteries and RCS propellant as much as possible. This meant that the LM should be retained through as much of the pre-entry sequence as possible, and that a plan for jettisoning the SM and the LM had to be worked out.

A first iteration plan for the pre-entry phase was available as early as 12 hours after the LM activation. This plan called for CM powerup 2 hours before arrival at the entry interface (EI - 2 hours), and required the total remaining capacity from the CM entry batteries, 98 amp-hours. After the plan was thoroughly reviewed by all elements of the operations team, including mission planning and flight crew support personnel, several modifications and additions were considered necessary. The principal difficulty was that the crew would probably be rushed, and there was little or no extra time allowed for contingencies. It was evident that the timeline needed to be extended and the CM

batteries would have to be recharged to at least 115 amp-hours. The recharging was accomplished and the procedure is described in Part A2 of Appendix A.

The White Team, one of the four flight control teams assigned to the mission, was taken off its normal rotation of duty in order to devote full attention to developing the reentry preparation sequence of events, crew procedures, and checklists. With this flight control team as the lead element, all MSC organizations normally involved in this type of premission activity were enlisted in this effort. In the course of defining the procedures, extensive use was made of the spacecraft simulators at MSC and KSC. These simulations, performed by members of the backup crews, served two essential purposes. The first was simply to evaluate them--to determine if they were practical, safe, efficient, and adequate. The second purpose was to determine the time required to complete certain parts of the procedures. The latter was important because a completely defined timeline had to be given to the crew in order to insure that everything was accomplished on time. It was essential that this timeline be realistic because the crew could not afford to get behind and fail to complete it, but neither could they start too early and use too much power from the CM batteries.

Another source of data used to develop the procedures was a series of contingency separation studies that was performed prior to the flight by mission planning personnel. These studies had examined the trajectory-related considerations for several different methods of jettisoning the SM and the LM. They had defined the effects of different attitudes, time, and velocity of jettison on the subsequent separation distances. It was only necessary to verify that these studies were valid for the Apollo 13 conditions, and then select the one with the most optimum characteristics.

The planning and evaluation of the pre-entry activities continued for approximately 2 days. At the end of this time, a complete plan had been defined and thoroughly reviewed. It was read to the crew at about 120 hours g.e.t., which gave them about a day to study and rehearse their procedures.

The pre-entry sequence plan (fig. B6-10) called for initiating the powerup at EI - $6\frac{1}{2}$ hours, with the LM supplying power to main bus B in the CM and entry battery C supplying power to main bus A. A total of 115 amp-hours was required of the CM entry batteries, including a 23 amp-hour allowance for contingency after splashdown. A detailed expected battery current profile was plotted and used during the actual preparation to verify that a safe power margin was maintained throughout the reentry preparations. Battery utilization was planned so that all three entry batteries would be available throughout the entry phase. It

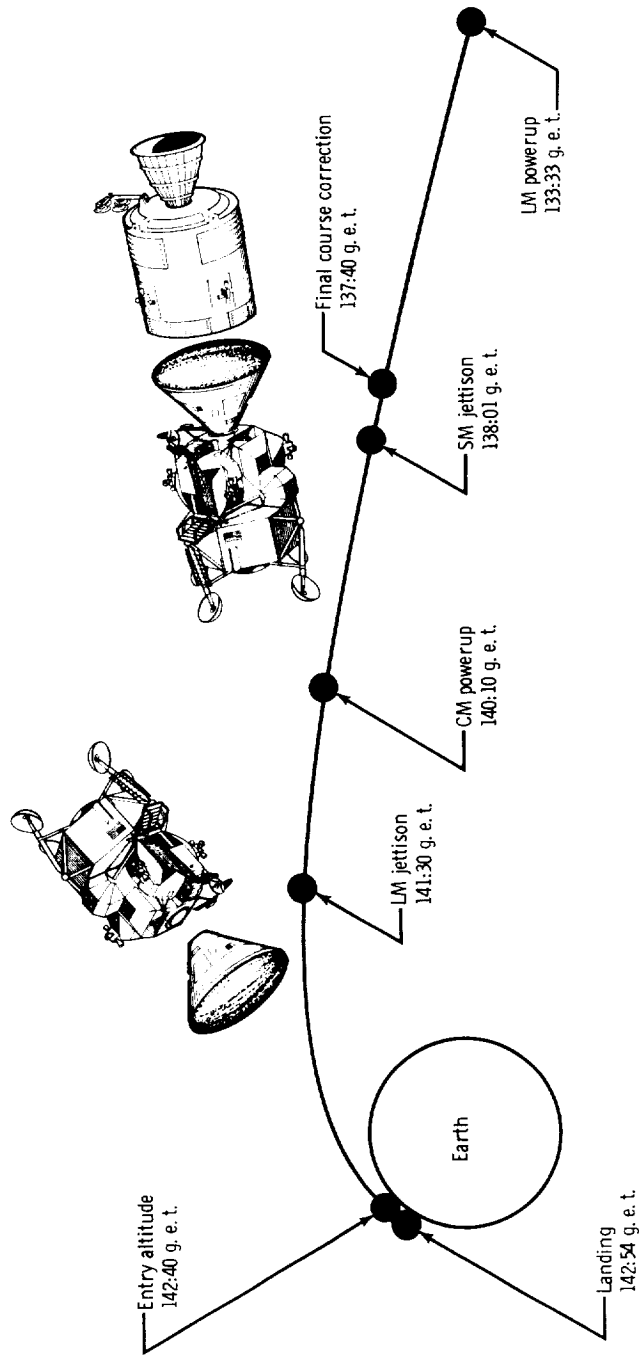

Figure B6-10.- Pre-reentry sequence milestones.

was predicted that battery C would be depleted after deployment of the main chutes, and in fact it was. This left the redundant capability of two batteries available to inflate the uprighting bags after splashdown.

The initial part of the reentry preparations, LM powerup, was performed about 3 hours earlier than planned. The crew was not resting comfortably due to the cold environment, and since there was ample margin in the LM batteries and water tanks, it was decided to turn on some equipment to try to warm up the spacecraft.

After activating the LM guidance and control system, the first major milestone in the entry sequence was to execute the final course correction to place the spacecraft on a trajectory that was in the center of the safe entry corridor. Prior to the final course correction, the trajectory had an entry angle error of about +0.5 degree, which is a safe condition, but slightly shallow (fig. B6-11). It is a standard practice to perform a final trim maneuver a few hours prior to entry to try to remove any entry angle error greater than ± 0.1 degree, and this course correction was incorporated in the timeline before it was known whether or not it could be required.

The planned procedures for the final course correction were the same as for the earlier one performed at about 104 hours g.e.t., including the alignment procedure which only required sighting the Earth through the COAS. Manual control of the actual delta V maneuver was also planned. However, since the LM powerup was started 3 hours earlier than originally expected, it was decided to use part of this time to align the LM inertial platform. This was done with the crew sighting on the Moon and the Sun for orientation determination. A further modification to the planned procedures of using the primary guidance system to perform the course correction had to be abandoned, because the attitude error indications did not behave properly. It was suspected that there might be something wrong with the guidance computer, so the crew performed the maneuver manually, following the original plan. Subsequent analysis has shown that the attitude error indications were not indicative of a system problem, but were a result of the guidance system activation procedures. These same indications did not show up in the simulator evaluations performed before the crew was given the procedures because of the limitations of simulator initialization.

The service module jettison was the next major milestone in the pre-entry sequence. It was performed at about 4-1/2 hours prior to reentry. The techniques used and the attitude and delta V requirements for it were obtained from premission studies. Basically, the technique was very similar to that used by a railroad switch engine to get rid of the end boxcar. The spacecraft was given an impulse with the LM RCS that caused a velocity change in the desired direction of about 0.5 fps; the CM/SM separation pyrotechnics were fired, physically disconnecting

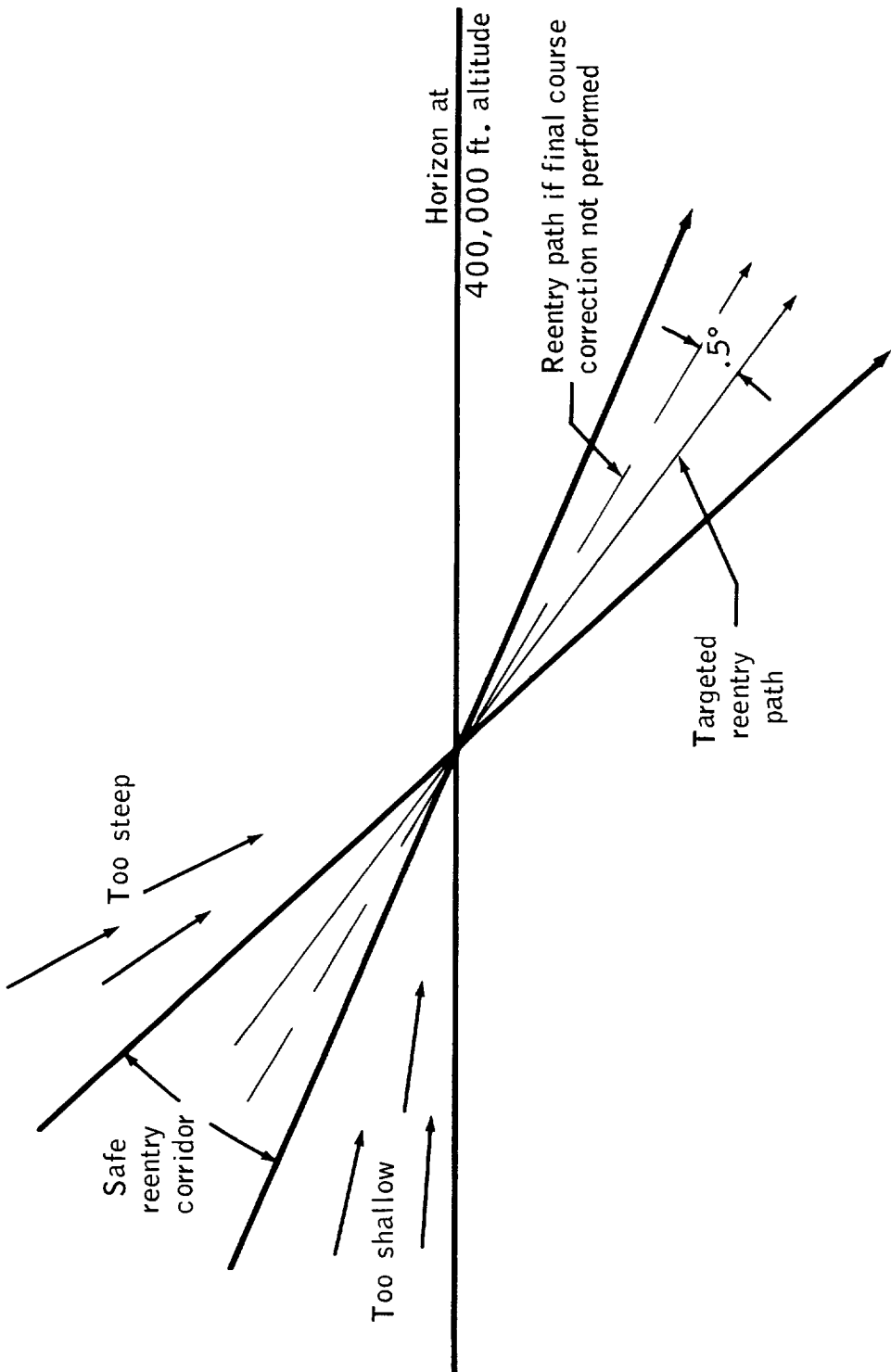

Figure B6-11.- Flight path angle and the safe reentry corridor.

the two modules; and a velocity change of the LM and CM was accomplished by reverse thrust from the LM RCS. The service module continued to translate relative to the manned modules, and separated from them at a rate of 0.5 fps. The normal method of using SM RCS jets to drive the SM away would not work because there was no way to get electrical power to keep the jets firing after CM/SM separation. The fuel cells which normally perform this function were inoperative.

The next major step was to get the CM inertial platform aligned. An automatic guidance controlled reentry was planned, which meant that the platform needed to be aligned to a known reference direction. There were several methods that could have been used to accomplish this, and a considerable amount of time was spent by the White Team in determining the best one. The selected plan used the docked align transfer procedure to get the CM platform coarsely aligned to the LM platform. The CM platform was then very accurately aligned to the desired direction by optical sightings with the CM sextant. Mission Control was standing by with an alternate procedure in case stars could not be seen through the CM optics; however, this was not necessary.

There was much interference on the voice and telemetry communication signals during this time period, which was later diagnosed to be due to the spacecraft attitude. Apparently the spacecraft was oriented so that the LM structure was blocking the signal from all of the omni antennas arrayed around the CM, and the received signal strength was very low. The antenna blockage problem was not recognized and several reconfigurations of the communication equipment were made to try to correct the problem, none of which were successful. In order to maintain adequate signal strength, it was necessary to receive data at the low bit rate only. This was not a major handicap, but it did cause some delay in completing the preparation of the CM guidance system for reentry.

The LM jettison from the CM was accomplished at about 1 hour prior to reentry. The attitude was based on premission studies, but no technique had been defined for achieving the actual separation with LM jettison from the CM only (no service module). The technique was defined by the White Team and consisted of using pressure in the LM/CM tunnel to impart a relative velocity to the two modules when the final separation pyrotechnics were fired. This method of separation had inadvertently occurred at the LM final jettison on Apollo 10 and was known to give sufficient separation velocity.

It was planned to jettison the LM in a direction 45 degrees south of the spacecraft plane of motion; however, the crew maneuvered the spacecraft to an attitude 65 degrees north of this plane. Mission Control was monitoring the spacecraft attitude, but did not realize the mistake until the crew was in the process of final closeout of the LM. Flight controllers quickly analyzed the situation and determined that,

although the 65 degrees north attitude did not give as much separation, it was acceptable. The major problem in being in error by 110 degrees was that it placed the CM in an attitude much closer to gimbal lock than is normally done. The crew had to be especially alert during the jettison and to use manual control of the CM to avoid gimbal lock.

The remainder of the sequence, from LM jettison to splashdown, followed normal procedures. The only difference was that the CM was completely independent of other spacecraft components at 1 hour prior to reentry instead of the usual 15 minutes.

PART B7

INSTRUMENT SYSTEM CHARACTERISTICS

Part 7 provides additional technical information of systems design and characteristics which are pertinent to interpretation of data presented in earlier parts of this Appendix. The following systems are discussed:

Oxygen Tank Temperature Instrumentation

Oxygen Tank Quantity Instrumentation

Oxygen Tank Pressure Instrumentation

Apollo PCM Telemetry System

Mission Control

OXYGEN TANK TEMPERATURE MEASUREMENT

The temperature measurement is made with a platinum resistance thermometer (R/T) encased in an Inconel sheath attached to the Teflon insulator part of the quantity probe (fig. B7-1). The resistance of the R/T and the transducer output voltage increase with temperature. The signal conditioner which serves as a reference voltage generator and amplifier is located on the oxygen tank shelf. An electrical schematic of the transducer is shown in figure B7-2.

The system electrical and performance parameters can be summarized as follows:

Data sample rate	one per second
Range	-320° F to +80° F
Corresponding R/T values	71 to 553 ohms
Output voltage	0 to 5 V dc
Accuracy	±2.68 percent or ±11° F
Output impedance	5000 ohms

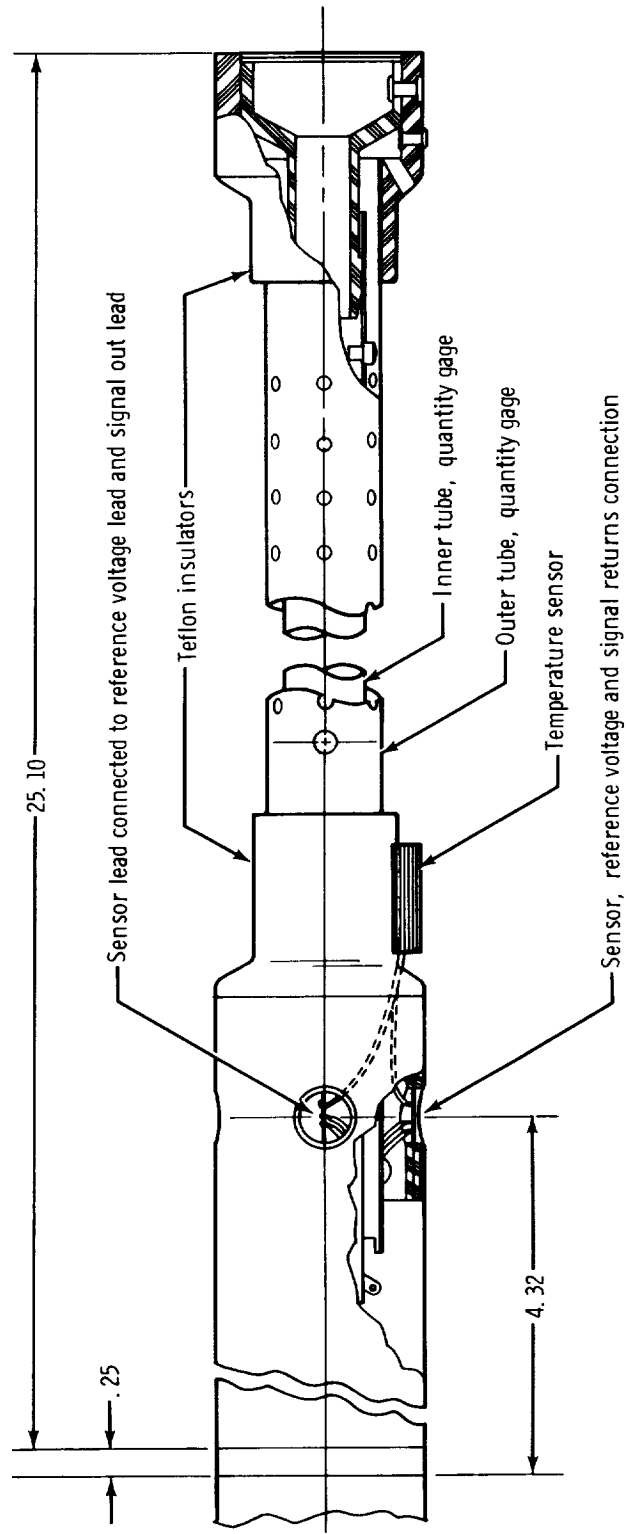
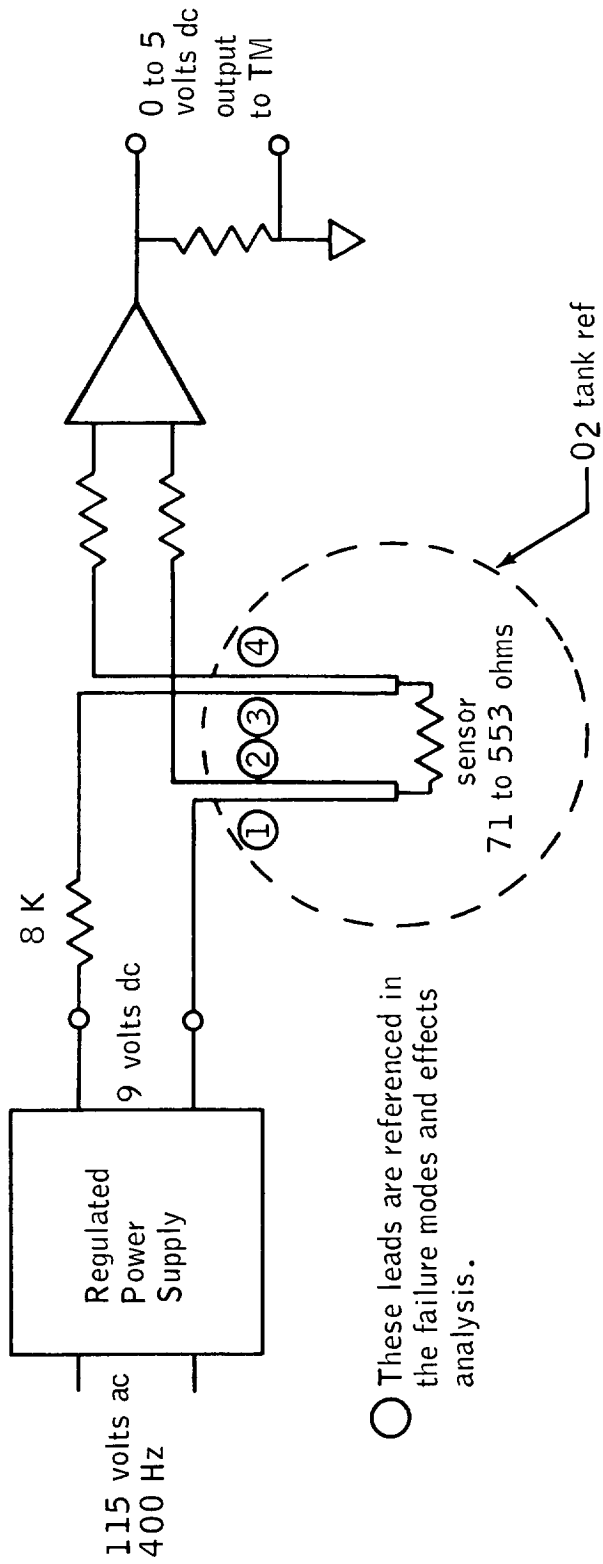

Figure B7-1. - Oxygen quantity gage and temperature sensor location.



○ These leads are referenced in the failure modes and effects analysis.

Figure B7-2.- Oxygen tank temperatures sensing circuit.

Power	1.25 watts, 115 V ac, 400 cps
Time constant in liquid nitrogen or alcohol	Approximately 20 seconds

The 20-second time constant was measured by plunging the sensor first into liquid nitrogen at -317° F and then into dry ice/alcohol at -91° F. Tests were made under one-g and 1 atmosphere and are not applicable to supercritical oxygen and zero-g.

Telemetry would indicate the temperature of the sensor itself, but under rapidly changing conditions the sensor could remain almost unaffected by local temperature changes in other parts of the tank. The effect of various failure modes on the transducer and its output signal are presented in table B7-I.

OXYGEN TANK QUANTITY INSTRUMENTATION

The oxygen tank quantity gage is shown in figure B7-1. This gage senses the average dielectric constant of oxygen in the cylindrical annular volume between two concentric aluminum tubes. The dielectric constant is proportional to density, which in turn is proportional to the quantity of oxygen in the tank. The gage is approximately 2 feet long; the outer tube is about 0.85-inch ID and the inner tube is about 0.65-inch OD to form two plates of a capacitor with 0.10-inch spacing. The gage mounts in the center of the tank.

The gage capacitance is connected in series with a reference capacity to form a capacitive 400-cycle ac voltage divider as shown in figure B7-3 and is adjusted to apply zero volts input to the amplifiers when the tank is empty. As the tank is filled, the gage capacity increases, applying a voltage to the amplifier input. This voltage is amplified and rectified to provide an output signal voltage which increases to 5 volts dc when the tank is full.

The reactive voltage developed across the probe capacitance will change as rapidly as capacitance changes. The rectifier filter on the output of the signal conditioner introduces a time constant of about 0.022 second in the instrument response.

TABLE B7-I.- FAILURE MODES OF THE OXYGEN TANK TEMPERATURE TRANSDUCER

Failure mode	Indication	Resulting damage
Any of the four temperature sensor leads shorted to 115 V ac line (1, 2, 3, 4)	Full scale output followed by zero output	Would fail signal conditioner amplifier, sensor element, and pulse code modulation gate
Temperature sensor shorted to the density probe element	*No change in output	Probably no circuit element damage
Temperature sensor shorted to ground (either side)	*Zero output signal	No circuit damage
Dc power shorted to temperature sensor	Full scale output	Would fail signal conditioner output
Either or both sensor leads open	Full scale output	None
400 Hz power input to power supply disconnected.	Output drifts to zero as charge in power supply filter capacitors discharge.	None
Temperature sensor leads shorted to each other	*Zero output	None
Any one of leads 1, 3, or 4 broken (open) (fig. B7-2)	Zero output	No circuit damage
Open lead 2 (fig. B7-1)	*Immediate rise to full scale followed by a linear decay to zero in approx. 10 msec	No circuit damage

*Indication verified by test

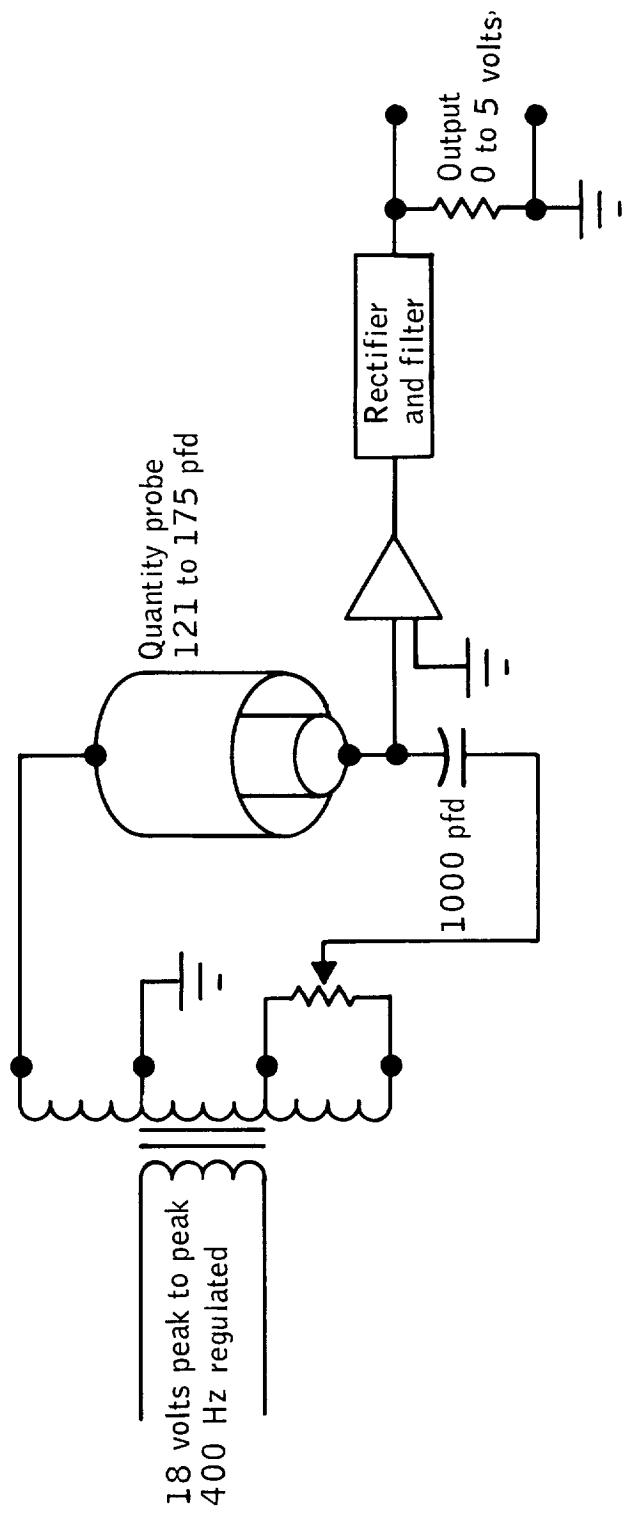

Figure B7-3.- Oxygen quantity gage block diagram.

Gage parameters are as follows:

Tank condition	Empty	Full
Density	0	69.5 lb/ft ³
Dielectric Constant	1.0	1.45
Capacitance	121	175 picofarads
Output voltage	0	5 V dc
Output impedance	500 ohms	
Power	2-1/2 watts	
Supply voltage	115 V, 400 cycles	
Accuracy	2.68 percent full scale	
Value of fixed capacitance	1000 picofarads	
Data sampled	Once per second	

This method of gaging works well for single-phase fluids in any gravity environment so long as the fluid is uniformly mixed with no significant density variations. But under zero-g, density and temperature variations can exist in the fluid, especially when heat is added without any fluid movement (convection). Under these conditions, the gage measures the average density of the oxygen between the two tubes which may or may not be representative of the average density in the tank.

If the gage is either opened or shorted, the signal conditioner is overdriven and a greater-than-100-percent quantity is indicated. Other malfunction characteristics follow.

<u>Failure Mode</u>	<u>Effect</u>
1. Elements of probe shorted to each other	Full scale output
2. Wire to either element disconnected from probe	Full scale output
3. Outside element of probe or its lead wire shorted to ground	Measurement indicates some value between zero and full scale
4. Inside element of probe or its lead shorted to ground	Random output tending towards zero
5. Clear shorted probe	Output decreases to zero, remains 0.7 second, then increases to correct value in about 1-1/2 second
6. Clear open probe fault	Output assumed correct value within 1/2 second
7. Intermittent shorts, any combination	Output becomes irregular sawtooth

OXYGEN TANK 2 PRESSURE INSTRUMENTATION

The location of the oxygen tank pressure measuring instrumentation is shown schematically in figure B7-4. Pressure transducers for both tanks are located in a valve module assembly along with the pressure switches and pressure relief valves as shown in figure B7-5. The valve module assembly is connected to the oxygen tanks by 19-foot lengths of 1/4-inch and 3/16-inch OD tubing.

The pressure transducer consists of a diaphragm 0.2 inch in diameter and 0.015 inch thick to which are attached 4 chips of strain-sensitive semi-conductor materials electrically connected into a bridge circuit. When pressure is applied, deflection of the diaphragm changes the electrical resistance of the semi-conductor clips to unbalance the bridge and develop an electrical output proportional to the applied pressure. This output is amplified so that full-scale pressure of 1050 psia gives a 5 V dc output which is indicated on the CM instrument panel and telemetered to the ground through the PCM telemetry system.

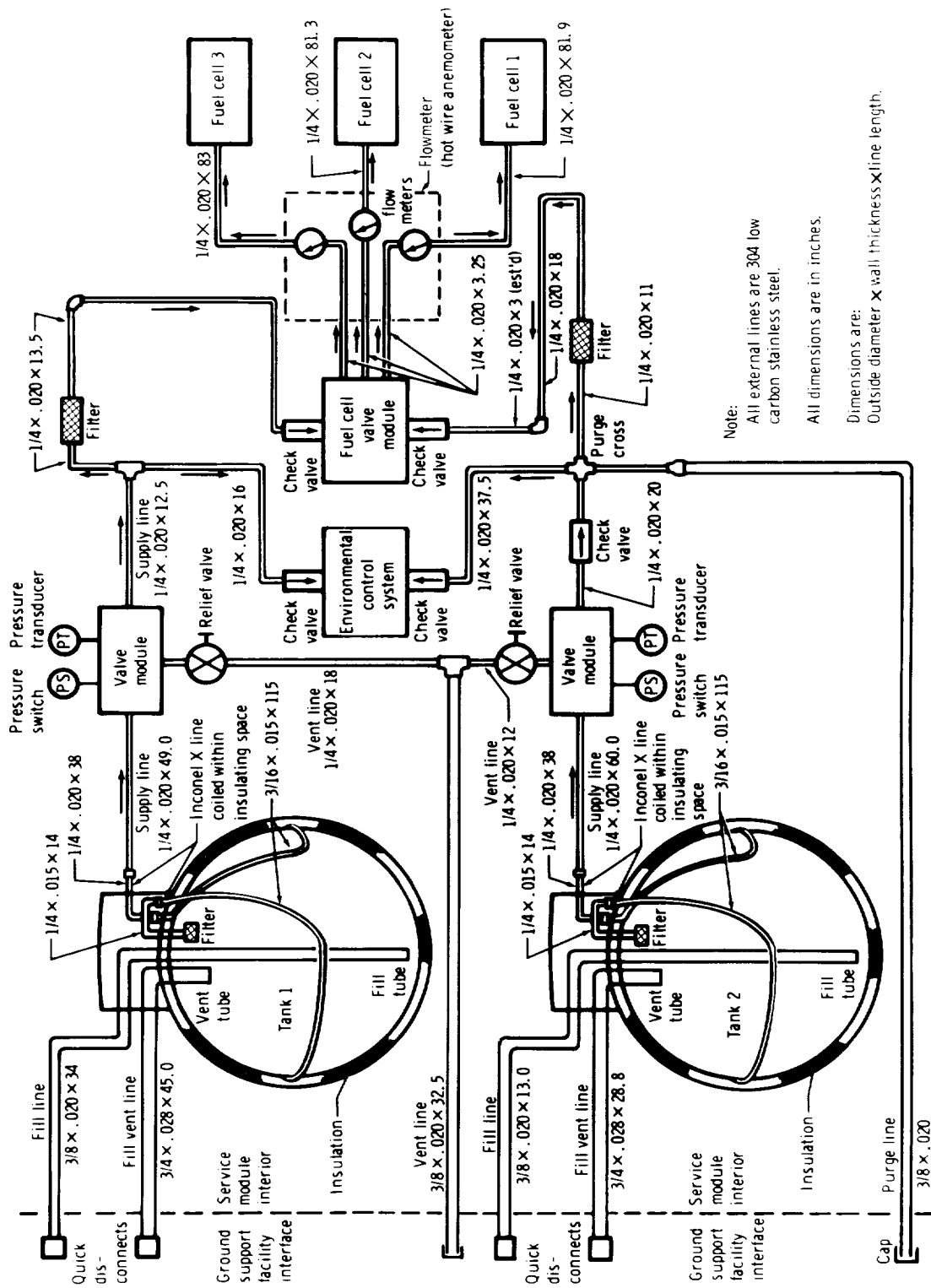

Note:
 All external lines are 304 low carbon stainless steel.
 All dimensions are in inches.
 Dimensions are: Outside diameter X wall thickness X line length.

Figure B7-4.- Oxygen system.

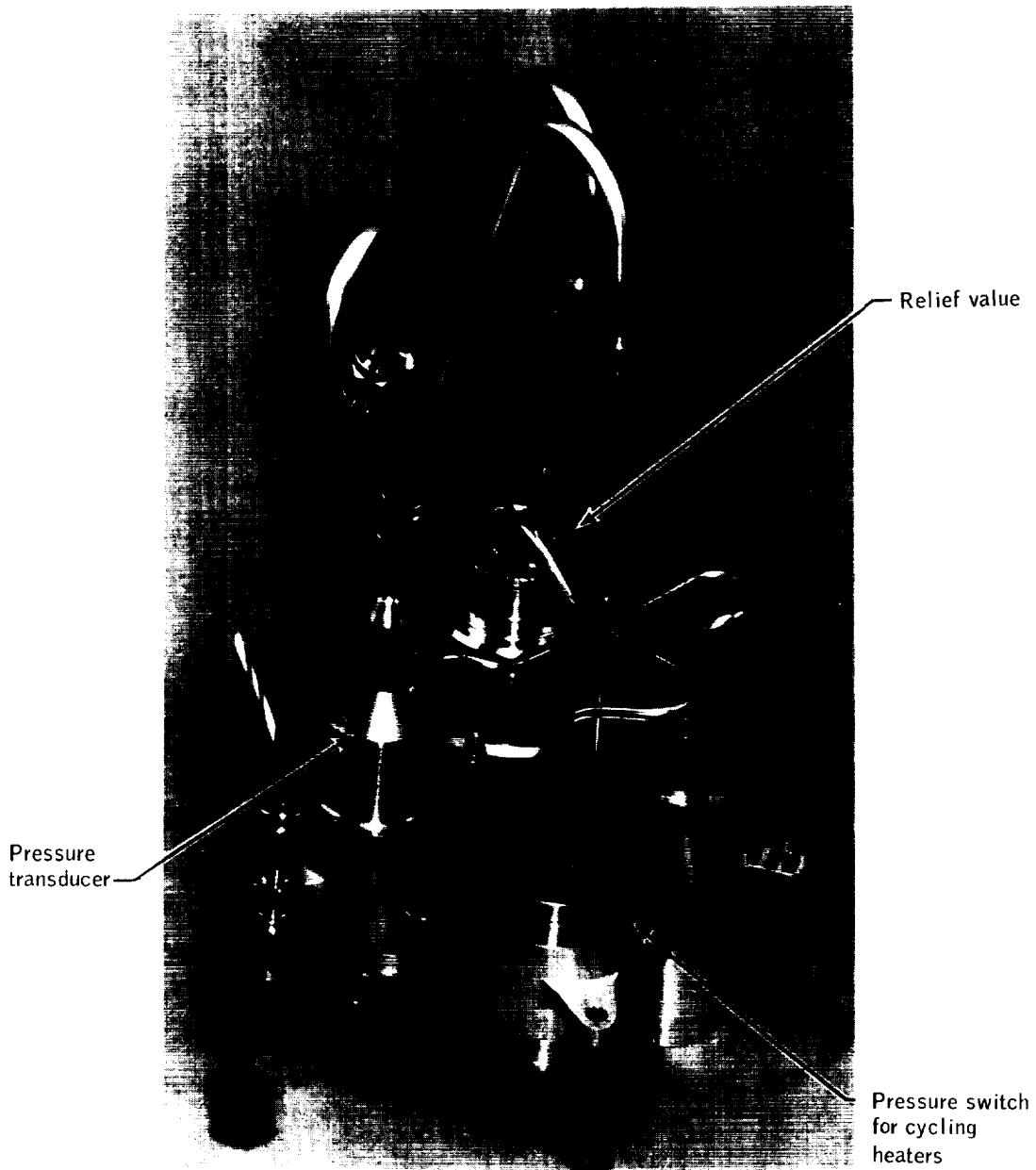

Figure B7-5.- Pressure transducer, relief valve, and pressure switch.

Other pressure transducer parameters are as follows:

Range	19 to 1080 psia
Accuracy	±2.68 percent fuel range
Output voltage	0 to 5 V dc
Output impedance	500 ohms
Power	1.5 watts
Voltage supply	28 V dc
Data sampled	Once per second

Under normal operating conditions oxygen flow through the 19 feet of tubing is about 1.5 pounds per hour and the pressure drop through the line is negligible.

The physical dimensions and electronic characteristics of the pressure transducer are such that its time lags are negligible as compared with acoustical lags of the tubing. If the relief valve opens (normally set at 1008 psia) or if the pressure in the tank changes suddenly, the delta P is communicated through the tube at sonic velocity (813 fps at 288° R) so that a delay of about 23 msec would be expected exclusive of pressure drops due to flow through the tubing. Tests run at MSC show that when a step pressure increase is applied at the tank end of the system, pressure indicated by the transducer begins to change in about 16 msec and reaches 63 percent of the pressure change in about 40 msec.

PULSE CODE MODULATION SYSTEM DESCRIPTION

The instrumentation system on the Apollo spacecraft interfaces with a pulse code modulation (PCM) telemetry system. In such a system, measurements are not presented continuously, but are sampled in time and quantized in amplitude. Signal conditioners standardize the outputs from all sensors to a range of 0 to 5 volts. This voltage is fed into the PCM system where it is sampled and encoded for transmission to the ground.

The PCM system basically consists of a number of electronic input switches and an analog-to-digital encoder, all of which are controlled by a programmer. The analog switches, through programmer control, are sampled sequentially with a sample period of 40 microseconds for each

input. The sampled voltage is then converted by the encoder into an 8-bit binary word which is subsequently transmitted to the ground. The sampling rate for each channel is selected on the basis of the rapidity with which that channel value changes under normal operation. Programmer sampling rates are 200, 100, 50, 10, and 1 sample per second. The end result of this operation when the system is in the high-bit-rate mode is a serial stream of data consisting of 128 eight-bit words in each frame with 50 frames transmitted each second. This corresponds to a bit rate of 51,200 bits per second. In the low-bit-rate mode, 1600 bits per second are transmitted and the measurements are made at a reduced sampling rate.

In evaluating telemetry data, consideration must be given to the fact that the system samples data in time and quantizes in amplitude.

Figure B7-6 depicts an analog signal and its equivalent digital representation to illustrate several limitations of PCM telemetry systems.

1. Fast transients which happen to occur between the sample times will not be recorded.

2. A long transient whose peak amplitude occurs between sample times will be recorded with an incorrect peak amplitude.

3. A low-amplitude transient may go completely unrecorded even if its peak amplitude occurs at a sample time.

4. A change of one count in a parameter does not necessarily mean that the analog quantity has changed by an amount equal to the difference in count values. If the analog quantity happens to be very close to the switchover point between counts, a small change can cause the count to change.

5. If the analog quantity remains for a long time close to the switchover point from one count to the next, the output may toggle (jump back and forth) from one count to another. This does not indicate that the analog value is actually changing this rapidly but is characteristic of the system when noise is present.

6. In addition to the phenomena illustrated in figure B7-6, it must be recognized that noise in the RF link may cause erroneous data to be received on the ground. Such errors usually appear in the data as values which differ greatly from adjacent outputs from the same channel.

Table B7-II lists the measurements telemetered from the Apollo 13 command and service modules as well as their ranges, sampling rates, and value of one count.

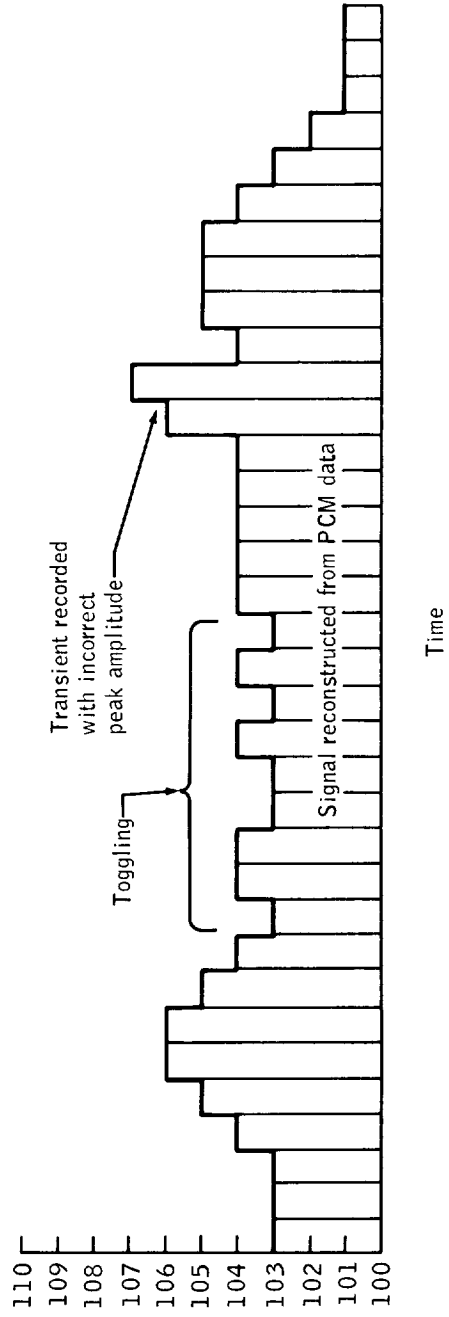
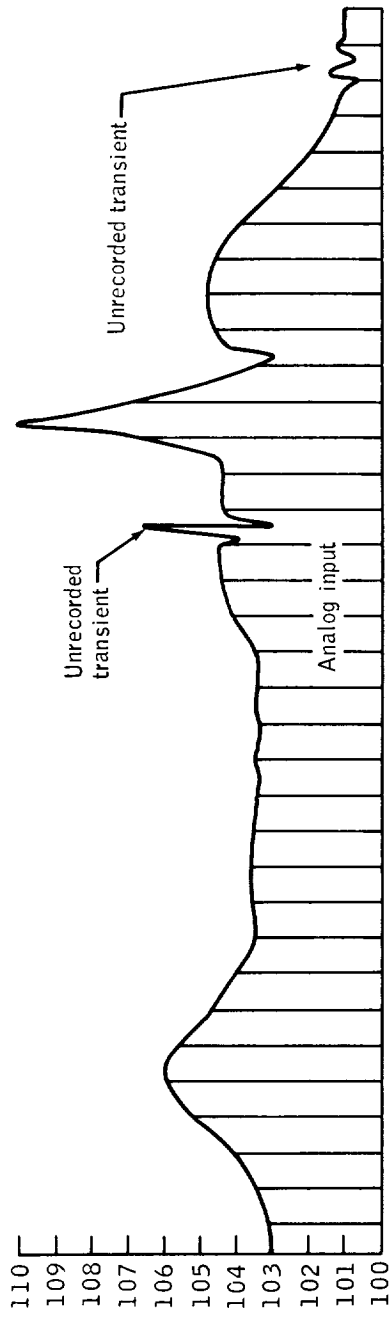

Figure B7-6.- Digital coding and reconstruction of analog signal.

TABLE B7-II.- COMMAND AND SERVICE MODULE TELEMETRY DATA SUMMARY

Measurement					Samples/Second		Units/Count
Number	Title	Unit	Approx. Range		High Bit Rate	Low Bit Rate	
			Low	High			
CA1820T	TEMP CREW HS ABL SUR LOC 1A	°F	-300	+850	1	-	4 - *NL
CA1821T	TEMP CREW HS ABL SUR LOC 4A	°F	-300	+850	1	-	4 - NL
CA1822T	TEMP CREW HS ABL SUR LOC 7A	°F	-300	+850	1	-	4 - NL
CA1823T	TEMP CREW HS ABL SUR LOC 10A	°F	-300	+850	1	-	4 - NL
SA1830T	TEMP SM SKIN SURF LOC 1A	°F	-120	+270	1	-	1.5 - NL
SA1831T	TEMP SM SKIN SURF LOC 4A	°F	-120	+270	1	-	1.5 - NL
SA1832T	TEMP SM SKIN SURF LOC 7A	°F	-120	+270	1	-	1.5 - NL
SA1833T	TEMP SM SKIN SURF LOC 10A	°F	-120	+270	1	-	1.5 - NL
SA2377T	TEMP BAY 2 OX TANK SURFACE	°F	-100	+200	1	-	1.2
SA2378T	TEMP BAY 3 OX TANK SURFACE	°F	-100	+200	1	-	1.2
SA2379T	TEMP BAY 5 FUEL TANK SURFACE	°F	-100	+200	1	-	1.2
SA2380T	TEMP BAY 6 FUEL TANK SURFACE	°F	-100	+200	1	-	1.2
SC0030Q	QUANTITY H2 TANK 1	PCT	0	100	1	1	0.4
SC0031Q	QUANTITY H2 TANK 2	PCT	0	100	1	1	0.4
SC0032Q	QUANTITY O2 TANK 1	PCT	0	100	1	1	0.4
SC0033Q	QUANTITY O2 TANK 2	PCT	0	100	1	1	0.4
SC0037P	PRESS O2 TANK 1	PSIA	20	1080	1	1	4.0
SC0038P	PRESS O2 TANK 2	PSIA	20	1080	1	1	4.0
SC0039P	PRESS H2 TANK 1	PSIA	0	350	1	1	1.5
SC0040P	PRESS H2 TANK 2	PSIA	0	350	1	1	1.5
SC0041T	TEMP O2 TANK 1	°F	-325	+80	1	1	1.6
SC0042T	TEMP O2 TANK 2	°F	-325	+80	1	1	1.6
SC0043T	TEMP H2 TANK 1	°F	-425	-200	1	1	1.0
SC0044T	TEMP H2 TANK 2	°F	-425	-200	1	1	1.0
CC0175T	TEMP STATIC INVERTER 1	°F	+32	+248	1	-	1
CC0176T	TEMP STATIC INVERTER 2	°F	+32	+248	1	-	1
CC0177T	TEMP STATIC INVERTER 3	°F	+32	+248	1	-	1 - NL
CC0200V	AC VOLTAGE MAIN BUS 1 PHASE A	VAC	0	+150	10	1	0.6
CC0203V	AC VOLTAGE MAIN BUS 2 PHASE A	VAC	0	+150	10	1	0.6
CC0206V	DC VOLTAGE MAIN BUS A	VDC	0	+45	10	1	0.18
CC0207V	DC VOLTAGE MAIN BUS B	VDC	0	+45	10	1	0.18

NL - Non Linear

TABLE B7-II.- COMMAND AND SERVICE MODULE TELEMETRY DATA SUMMARY - Continued.

Measurement					Samples/Second		Units/Count
Number	Title	Unit	Approx. Range		High Bit Rate	Low Bit Rate	
			Low	High			
CC0210V	DC VOLTAGE BATTERY BUS A	VDC	0	+45	10	1	0.18
CC0211V	DC VOLTAGE BATTERY BUS B	VDC	0	+45	10	1	0.18
CC0215C	DC CURRENT BATTERY CHARGER OUT	AMP	0	+5	10	1	0.02
CC0222C	DC CURRENT BATTERY A	AMP	0	+100	10	1	0.4
CC0223C	DC CURRENT BATTERY B	AMP	0	+100	10	1	0.4
CC0224C	DC CURRENT BATTERY C	AMP	0	+100	10	1	0.4
CC0232V	DC VOLTAGE BATTERY RELAY BUS	VDC	0	+45	10	1	0.18
SC2060P	N2 PRESSURE FC 1 REGULATED	PSIA	0	75	10	-	0.3
SC2061P	N2 PRESSURE FC 2 REGULATED	PSIA	0	75	10	-	0.3
SC2062P	N2 PRESSURE FC 3 REGULATED	PSIA	0	75	10	-	0.3
SC2066P	O2 PRESSURE FC 1 REGULATED	PSIA	0	75	10	-	0.3
SC2067P	O2 PRESSURE FC 2 REGULATED	PSIA	0	75	10	-	0.3
SC2068P	O2 PRESSURE FC 3 REGULATED	PSIA	0	75	10	-	0.3
SC2069P	H2 PRESSURE FC 1 REGULATED	PSIA	0	75	10	-	0.3
SC2070P	H2 PRESSURE FC 2 REGULATED	PSIA	0	75	10	-	0.3
SC2071P	H2 PRESSURE FC 3 REGULATED	PSIA	0	75	10	-	0.3
SC2081T	TEMP FC 1 COND EXHAUST	°F	+145	+250	1	1	0.4
SC2082T	TEMP FC 2 COND EXHAUST	°F	+145	+250	1	1	0.4
SC2083T	TEMP FC 3 COND EXHAUST	°F	+145	+250	1	1	0.4
SC2084T	TEMP FC 1 SKIN	°F	+80	+550	1	1	2
SC2085T	TEMP FC 2 SKIN	°F	+80	+550	1	1	2
SC2086T	TEMP FC 3 SKIN	°F	+80	+550	1	1	2
SC2087T	TEMP FC 1 RADIATOR OUTLET	°F	-50	+300	1	1	1.4
SC2088T	TEMP FC 2 RADIATOR OUTLET	°F	-50	+300	1	1	1.5
SC2089T	TEMP FC 3 RADIATOR OUTLET	°F	-50	+300	1	1	1.5
SC2090T	RAD INLET TEMP FC 1	°F	-50	+300	1	-	1.5
SC2091T	RAD INLET TEMP FC 2	°F	-50	+300	1	-	1.5
SC2092T	RAD INLET TEMP FC 3	°F	-50	+300	1	-	1.5
SC2113C	DC CURRENT FC 1 OUTLET	AMP	0	+100	10	1	0.4

TABLE B7-II.- COMMAND AND SERVICE MODULE TELEMETRY DATA SUMMARY - Continued.

Measurement					Samples/Second		Units/Count
Number	Title	Unit	Approx. Range		High Bit Rate	Low Bit Rate	
			Low	High			
SC2114C	DC CURRENT FC 2 OUTPUT	AMP	0	+100.0	10	1	0.4
SC2115C	DC CURRENT FC 3 OUTPUT	AMP	0	+100.0	10	1	0.4
SC2139R	FLOW RATE H2 FC 1	LB/HR	0	.2	10	-	.001 - NL
SC2140R	FLOW RATE H2 FC 2	LB/HR	0	.2	10	-	.001 - NL
SC2141R	FLOW RATE H2 FC 3	LB/HR	0	.2	10	-	.001 - NL
SC2142R	FLOW RATE O2 FC 1	LB/HR	0	1.7	10	-	.005 - NL
SC2143R	FLOW RATE O2 FC 2	LB/HR	0	1.7	10	-	.005 - NL
SC2144R	FLOW RATE O2 FC 3	LB/HR	0	1.7	10	-	.005 - NL
SC2160X	PH FACTOR WATER COND FC 1		NORM	HIGH	10	1	
SC2161X	PH FACTOR WATER COND FC 2		NORM	HIGH	10	1	
SC2162X	PH FACTOR WATER COND FC 3		NORM	HIGH	10	1	
CC2962C	CSM TO LEM CURRENT MONITOR	AMP	0	+10	10	1	0.04
CD0005V	DC VOLTAGE PYRO BUS A	VDC	0	+40	10	-	0.15
CD0006V	DC VOLTAGE PYRO BUS B	VDC	0	+40	10	-	0.15
CD0023X	CM-SM RELAY CLOSE A			SEP	10	1	
CD0024X	CM-SM SEP RELAY CLOSE B			SEP	10	1	
CD0123X	SLA SEPARATION RELAY A			SEP	10	1	
CD0124X	SLA SEPARATION RELAY B			SEP	10	1	
CD0130X	HAND CONTROLLER INPUT A			ABORT	10	1	
CD0131X	HAND CONTROLLER INPUT B			ABORT	10	1	
CD0132X	EDS ABORT LOGIC INPUT NO 1		VOTE/ OFF	ARM	10	1	
CD0133X	EDS ABORT LOGIC INPUT NO 2		VOTE/ OFF	ARM	10	1	
CD0134X	EDS ABORT LOGIC INPUT NO 3		VOTE/ OFF	ARM	10	1	
CD0135X	EDS ABORT LOGIC OUTPUT A			ABORT	10	1	
CD0136X	EDS ABORT LOGIC OUTPUT B			ABORT	10	1	
CD0170X	RCS ACTIVATE SIG A			ENABLE	10	1	
CD0171X	RCS ACTIVATE SIG B			ENABLE	10	1	
CD0173X	CM RCS PRESS SIG A			PRESS	10	1	
CD0174X	CM RCS PRESS SIG B			PRESS	10	1	
CD0200V	DC VOLTAGE LOGIC BUS A	VDC	0	+40	10	-	0.15

NL - Non Linear

TABLE B7-II.- COMMAND AND SERVICE MODULE TELEMETRY DATA SUMMARY - Continued.

Measurement					Samples/Second		Units/Count
Number	Title	Unit	Approx. Range		High Bit Rate	Low Bit Rate	
			Low	High			
CD0201V	DC VOLTAGE LOGIC BUS B	VDC	0	+40	10	-	0.15
CD0230X	FWD HS JETTISON A			JETT	10	1	
CD0231X	FWD HS JETTISON B			JETT	10	1	
CD1154X	CSM-LEM LOCK RING SEP RELAY A			SEP	10	1	
CD1155X	CSM-LEM LOCK RING SEP RELAY B			SEP	10	1	
CE0001X	DROGUE DEPLOY RELAY CLOSE A			DEPLOY	10	1	
CE0002X	DROGUE DEPLOY RELAY CLOSE B			DEPLOY	10	1	
CE0003X	MAIN CHUTE DEPL DRG REL RLY A			DEPLOY	10	1	
CE0004X	MAIN CHUTE DEPL DRG REL RLY B			DEPLOY	10	1	
CE0321X	MAIN CHUTE DISCON- NECT RELAY A			DISC	10	1	
CE0322X	MAIN CHUTE DISCON- NECT RELAY B			DISC	10	1	
CF0001P	PRESSURE CABIN	PSIA	0	17	1	1	0.067
CF0002T	TEMP CABIN	°F	+40	+125	1	1	0.3 - NL
CF0003P	PRESS O2 SUIT TO CABIN DIFF	IN H2O	-5	+5	10	-	0.04
CF0005P	PRESS CO2 PARTIAL	MM HG	0	30.00	1	1	0.12 - NL
CF0006P	PRESS SURGE TANK	PSIA	30	1080	10	1	4
CF0008T	TEMP SUIT SUPPLY MANIF	°F	+20	+95	1	1	0.3
CF0009Q	QUANTITY WASTE WATER TANK	PCT	0	100	1	1	0.4 - NL
CF0010Q	QUAN POTABLE H2O TANK	PCT	0	100	1	1	0.3 - NL
CF0012P	PRESS SUIT DEMAND REG SENSE	PSIA	0	17	10	1	0.07
CF0015P	PRESS SUIT COM- PRESSOR DIFF	PSID	0	1.00	10	1	0.0035 - NL
CF0016P	PRESS GLYCOL PUMP OUTLET	PSIG	0	60	10	1	0.24
CF0017T	TEMP GLYCOL EVAP OUTLET STEAM	°F	+20	+95	1	-	0.3
CF0018T	TEMP GLY EVAP OUTLET LIQUID	°F	+25	+75	1	1	0.2
CF0019Q	QUANTITY GLYCOL ACCUM	PCT	0	107	10	1	0.5 - NL
CF0020T	TEMP SPACE RADI- ATOR OUTLET	°F	-50	+100	1	1	0.6 - NL
CF0034P	BACK PRESS GLYCOL EVAPORATOR	PSIA	0	0.25	1	-	0.0008
CF0035R	FLOWRATE ECS O2	LB/HR	0.16	1	10	-	0.003 - NL
CF0036P	PRESS OUTLET O2 REG SUPPLY	PSIG	0	150	10	1	0.6

NL - Non Linear

TABLE B7-II.- COMMAND AND SERVICE MODULE TELEMETRY DATA SUMMARY - Continued.

Measurement			Samples/Second				Units/Count
Number	Title	Unit	Approx. Range		High Bit Rate	Low Bit Rate	
			Low	High			
CF0070P	PRESS SEC GLYCOL PUMP OUTLET	PSIG	0	60	10	1	0.24
CF0071T	TEMP SEC EVAP OUTLET LIQUID	°F	+25	+75	10	1	0.2
CF0072Q	QUANTITY SEC GLYCOL ACCUM	PCT	0	100	10	1	0.8 - NL
CF0073P	PR SECONDARY EVAP OUT STEAM	PSIA	0.05	0.25	1	-	0.0008
CF0120P	PRESS H2O AND GLYCOL TANKS	PSIA	0	50	1	-	0.2
CF0157R	RATE GLYCOL FROM THERMAL LOAD	LB/HR	45	330	10	-	0.9 - NL
CF0181T	TEMP GLYCOL EVAP INLET	°F	+35	+100	1	-	0.3
SF0260T	TEMP PRIMARY RADIATOR INLET	°F	+55	+120	1	1	0.25
SF0262T	TEMP SECONDARY RADIATOR INLET	°F	+55	+120	1	1	0.25
SF0263T	TEMP SEC RADIATOR OUTLET	°F	+30	+70	1	1	0.15
SF0266X	RADIATOR FLOW CONT SYS 1 OR 2		SYS 1	SYS 2	10	1	
CF0460T	TEMP URINE DUMP NOZZLE	°F	0	+100	1	1	0.4
CF0461T	TEMP WASTE WATER DUMP NOZZLE	°F	0	+100	1	1	0.4
CG1040V	120 VDC PIPA SUPPLY DC LEVEL	VDC	+84	+135	1	-	0.2
CG1110V	2.5 VDC TM BIAS	VDC	0	5	1	1	0.02
CG1201V	IMU 28V .8KC 1 PCT	VRMS	0	30	1	-	0.12 - NL
CG1331V	3.2KC 28V SUPPLY	VRMS	0	30	1	-	0.12 - NL
CG1513X	28V IMU STANDBY		OFF	STBY	10	1	
CG1523X	28V CMC OPERATE		OFF	OPR	10	1	
CG1533X	28V OPTX OPERATE		OFF	OPR	10	1	
CG2112V	IG 1X RESOLVER OUTPUT SIN	VRMS	-21	+21	10	-	0.17
CG2113V	IG 1X RESOLVER OUTPUT COS	VRMS	-21	+21	10	-	0.17
CG2117V	IGA SERVO ERROR IN PHASE	VRMS	-3	+3	100	-	0.025
CG2142V	MG 1X RESOLVER OUTPUT SIN	VRMS	-21	+21	10	-	0.16
CG2143V	MG 1X RESOLVER OUTPUT COS	VRMS	-20	+40	10	-	0.16
CG2147V	MGA SERVO ERROR IN PHASE	VRMS	-3	+3	100	-	0.024
CG2172V	OG 1X RESOLVER OUTPUT SINE	VRMS	-21	+21	10	-	0.16

NL - Non Linear

TABLE B7-II.- COMMAND AND SERVICE MODULE TELEMETRY DATA SUMMARY - Continued.

Measurement					Samples/Second		Units/Count
Number	Title	Unit	Approx. Range		High Bit Rate	Low Bit Rate	
			Low	High			
CG2173V	OG 1X RESOLVER OUT-PUT COS	VRMS	-21	+21	10	-	0.16
CG2177V	OGA SERVO ERROR IN PHASE	VRMS	-3	+3	100	-	0.025
CG2300T	PIFA TEMPERATURE	°F	+119	+140	1	1	0.08
CG3721V	SHAFT CDU DAC OUT-PUT	VRMS	-12	+12	10	-	0.09
CG3722V	TRUNNION CDU DAC OUTPUT	VRMS	-12	+12	10	-	0.09
CG5040X	CMC WARNING		WARN		10	1	
CH3500H	FDAI CM/SM ATT ERROR PITCH	DEG	-5 -15	+5 +15	50	-	MM
CH3501H	FDAI CM/SM ATT ERROR YAW	DEG	-5 -15	+5 +15	50	-	MM
CH3502H	FDAI CM/SM ATT ERROR ROLL	DEG	-5 -50	+5 +50	100	-	MM
CH3503R	FDAI SCS BODY RATE PITCH	DEG/ SEC	-1 -5 -10	+1 +5 +10	100	-	MM
CH3504R	FDAI SCS BODY RATE YAW	DEG/ SEC	-1 -5 -10	+1 +5 +10	100	-	MM
CH3505R	FDAI SCS BODY RATE ROLL	DEG/ SEC	-1 -5 -50	+1 +5 +50	100	-	MM
CH3517H	GIMBAL POSITION PITCH 1 OR 2	DEG	-5	+5	100	-	0.04
CH3518H	GIMBAL POSITION YAW 1 OR 2	DEG	-5	+5	100	-	0.04
CH3546X	RCS SOLENOID ACT C3/13/X		FIRE/ OFF	ARM	200	-	
CH3547X	RCS SOLENOID ACT A4/14/X		FIRE/ OFF	ARM	200	-	
CH3548X	RCS SOLENOID ACT A3/23/-X		FIRE/ OFF	ARM	200	-	
CH3549X	RCS SOLENOID ACT C4/24/-X		FIRE/ OFF	ARM	200	-	
CH3550X	RCS SOLENOID ACT D3/25/X		FIRE/ OFF	ARM	200	-	
CH3551X	RCS SOLENOID ACT B4/26/X		FIRE/ OFF	ARM	200	-	
CH3552X	RCS SOLENOID ACT B3/15/-X		FIRE/ OFF	ARM	200	-	
CH3553X	RCS SOLENOID ACT D4/16/-X		FIRE/ OFF	ARM	200	-	
CH3554X	RCS SOLENOID ACT B1/11/Z		FIRE OFF	ARM	200	-	
CH3555X	RCS SOLENOID ACT D2/22/Z		FIRE/ OFF	ARM	200	-	

MM - Multiple Mode Calibration

TABLE B7-II.- COMMAND AND SERVICE MODULE TELEMETRY DATA SUMMARY - Continued.

Measurement				Samples/Second		Units/Count	
Number	Title	Unit	Approx. Range		High Bit Rate		Low Bit Rate
			Low	High			
CH3556X	RCS SOLENOID ACT D1/21/-Z		FIRE/ OFF	ARM	200	-	
CH3557X	RCS SOLENOID ACT B2/12/-Z		FIRE/ OFF	ARM	200	-	
CH3558X	RCS SOLENOID ACT A1/Y		FIRE/ OFF	ARM	200	-	
CH3559X	RCS SOLENOID ACT C2/Y		FIRE/ OFF	ARM	200	-	
CH3560X	RCS SOLENOID ACT C1/-Y		FIRE/ OFF	ARM	200	-	
CH3561X	RCS SOLENOID ACT A2/-Y		FIRE/ OFF	ARM	200	-	
CH3574X	TRANSLATIONAL CONTROLLER XC MD		OFF	ON	10	1	
CH3575X	TRANSLATIONAL CONTROLLER-XC MD		OFF	ON	10	1	
CH3576X	TRANSLATIONAL CONTROLLER YC MD		OFF	ON	10	1	
CH3577X	TRANSLATIONAL CONTROLLER -YC MD		OFF	ON	10	1	
CH3578X	TRANSLATIONAL CONTROLLER ZC MD		OFF	ON	10	1	
CH3579X	TRANSLATIONAL CONTROLLER -SC MD		OFF	ON	10	1	
CH3582V	SCS TVC AUTO COM- MAND PITCH	VDC	-10	+10	100	-	0.08
CH3583V	SCS TVC AUTO COM- MAND PITCH	VDC	-10	+10	100	-	0.08
CH3585H	ROT CONTROL/MTVC PITCH	VDC	-10	+10	50	-	0.078
CH3586H	ROT CONTROL/MTVC YAW CMC	VDC	-10	+10	50	-	0.08
CH3587H	ROT CONTROL/MTVC ROLL CMC	DEG	-11	+11	50	-	0.087
CH3588X	ATTITUDE DEADBAND MINIMUM		MAX	MIN	10	1	
CH3590X	HIGH PRO RATE LIMIT		LOW	HIGH	10	1	
CH3592X	FDAI SCALE ERROR 5, RATE 5		OFF	ON	10	1	
CH3593X	FDAI SCALE ERROR 50/15, RT50/10		OFF	ON	10	1	
CH3600X	SCS DELTA V CG-LM/CSM POS		CSM	LM/ CSM	10	1	
CH3601X	DIR RCS SW NO 1 ENABLE POS		OFF	ENABLE	10	1	
CH3602X	DIR RCS SW NO 2 ENABLE POS		OFF	ENABLE	10	1	
CH3604X	SPS SOLENOID DRIVER NO 1		FIRE/ OFF	ARM	10	1	
CH3605X	SPS SOLENOID DRIVER NO 2		FIRE/ OFF	ARM	10	1	

TABLE B7-II.- COMMAND AND SERVICE MODULE TELEMETRY DATA SUMMARY - Continued.

Measurement					Samples/Second		Units/Count
Number	Title	Unit	Approx. Range		High Bit Rate	Low Bit Rate	
			Low	High			
CH3606X	LIMIT CYCLE SW OFF POS		ON	OFF	10	1	
CH3607X	SC CONTROL SOURCE SWITCH		CMC	SCS	10	1	
CH3609X	ROLL MAN ATT SW ACCEL CMD POS		OFF	ON	10	1	
CH3610X	R MAN ATT SW MIN IMP CMD POS		OFF	ON	10	1	
CH3612X	PITCH MAN ATT SW ACCEL CMD POS		OFF	ON	10	1	
CH3613X	P MAN ATT SW MIN IMP CMD POS		OFF	ON	10	1	
CH3615X	YAW MAN ATT SW ACCEL CMD POS		OFF	ON	10	1	
CH3616X	YAW MAN ATT SW MIN IMP CMD POS		OFF	ON	10	1	
CH3623X	GYRO 1 COMB SPIN MTRS RUN DET		LOW	NORM	10	1	
CH3624X	GYRO 2 COMB SPIN MTRS RUN DET		LOW	NORM	10	1	
CH3635X	BMAG MODE SW-ROLL ATT 1 RT 2		OFF	ON	10	-	
CH3636X	BMAG MODE SW-ROLL RATE 2		OFF	ON	10	-	
CH3638X	BMAG MODE SW-PITCH ATT 1 RT 2		OFF	ON	10	-	
CH3639X	BMAG MODE SW-PITCH RATE 2		OFF	ON	10	-	
CH3641X	BMAG MODE SW-YAW ATT 1 RT 2		OFF	ON	10	-	
CH3642X	BMAG MODE SW-YAW RATE 2		OFF	ON	10	-	
CH3666C	TVC PITCH DIFF CURRENT	MAMP	-800	+800	200	-	
CH3667C	TVC YAW DIFF CURRENT	MAMP	-800	+800	100	-	
CJ0060J	EKG COMMANDER LH COUCH	MV	NA	NA	200	-	
CJ0061J	EKG COMMANDER CTR COUCH	MV	NA	NA	200	-	
CJ0062J	EKG LM PILOT RH COUCH	MV	NA	NA	200	-	
CJ0200R	RESP RATE CMD, CM/LM PILOT	OHM	NA	NA	50	-	
CJ0201R	RESP RATE CM PILOT CTR COUCH	OHM	NA	NA	50	-	
CJ0202R	RESP RATE LM PILOT RH COUCH	OHM	NA	NA	50	-	
CK0026A	CM ACCEL X-AXIS	G	-2	+10	100	-	0.05
CK0027A	CM ACCEL Y-AXIS	G	-2	+2	100	-	0.016

TABLE B7-II.- COMMAND AND SERVICE MODULE TELEMETRY DATA SUMMARY - Continued.

Measurement					Samples/Second		Units/Count
Number	Title	Unit	Approx. Range		High Bit Rate	Low Bit Rate	
			Low	High			
CK0028A	CM ACCEL Z-AXIS	G	-2	+2	100	-	0.016
CK1051K	RADIATION DOS- IMETER 1	VDC	0	5	10	-	0.02 - NL
CK1052K	RADIATION DOS- IMETER 2	VDC	0	5	10	-	0.02 - NL
CK1053R	DOSIMETER RATE CHANGE	VDC	0	5	1	-	0.02 - NL
CK1043	70mm HASSELBLAD		OFF	ON	100	-	
CK1044	70mm LUNAR PHOTOG- RAPHY		OFF	ON	100	-	
SP0001P	HE PRESS TANK	PSIA	0	5000	10	1	21
SP0002T	HE TEMP TANK	°F	-100	+200	1	-	1.2
SP0003P	PRESS OXIDIZER TANKS	PSIA	0	250	10	1	1
SP0006P	PRESS FUEL TANKS	PSIA	0	250	10	1	1
SP0022H	POSITION FUEL/OX VLV 1 POT B	DEG	0	90	10	-	0.46
SP0023H	POSITION FUEL/OX VLV 2 POT B	DEG	0	90	10	-	0.46
SP0024H	POSITION FUEL/OX VLV 3 POT B	DEG	0	90	10	-	0.46
SP0025H	POSITION FUEL/OX VLV 4 POT B	DEG	0	90	10	-	0.46
SP0045T	TEMP ENG VALVE BODY	°F	0	+200	1	-	0.8
SP0048T	TEMP ENG FUEL FEED LINE	°F	0	+200	1	1	0.8
SP0049T	TEMP ENG OX FEED LINE	°F	0	+200	1	1	0.8
SP0054T	TEMP 1 OX DISTRI- BUTION LINE	°F	0	+200	1	-	0.8
SP0057T	TEMP 1 FUEL DISTRI- BUTION LINE	°F	0	+200	1	-	0.8
SP0061T	ENG INJECTOR FLANGE TEMP NO 1	°F	0	600	1	-	2.3
SP0062T	ENG INJECTOR FLANGE TEMP NO 2	°F	0	600	1	-	2.3
SP0600P	ENG VLV ACT SYS TANK PR PRI	PSIA	0	5000.	1	-	21
SP0601P	ENG VLV ACT SYS TANK PR SEC	PSIA	0	5000.	1	-	21
SP0655Q	QUAN OX TANK 1 PRI-TOTAL AUX	PCT	0	50	1	-	0.2
SP0656Q	QUAN OX TANK 2	PCT	0	60	1	-	0.2
SP0657Q	QUAN FUEL TANK 1 PRI-TOTAL AUX	PCT	0	50	1	-	0.2
SP0658Q	QUAN FUEL TANK 2	PCT	0	60	1	-	0.2
SP0661P	PRESS ENGINE CHAMBER	PSIA	0	150	100	-	0.6
SP0930P	PRESS FUEL SM/ENG INTERFACE	PSIA	0	300	10	-	1.3
SP0931P	PRESS OX SM/ENG INTERFACE	PSIA	0	300	10	-	1.3

TABLE B7-II.- COMMAND AND SERVICE MODULE TELEMETRY DATA SUMMARY - Continued.

Measurement					Samples/Second		Units/Count
Number	Title	Unit	Approx. Range		High Bit Rate	Low Bit Rate	
			Low	High			
CR0001P	HE PRESS TANK A	PSIA	0.	5000	1	1	21
CR0002P	HE PRESS TANK B	PSIA	0.	5000	1	1	21
CR0003T	HE TEMP TANK A	°F	0	+300	10	1	1.2
CR0004T	HE TEMP TANK B	°F	0	+300	10	1	1.2
CR0035P	PRESS CM-RCS HE MANIFOLD 1	PSIA	0	400	10	1	1.7
CR0036P	PRESS CM-RCS HE MANIFOLD 2	PSIA	0	400	10	1	1.7
SR5001P	HE PRESS TANK A	PSIA	0	5000	1	1	21
SR5002P	HE PRESS TANK B	PSIA	0	5000	1	1	21
SR5003P	HE PRESS TANK C	PSIA	0	5000	1	1	21
SR5004P	HE PRESS TANK D	PSIA	0	5000	1	1	21
SR5013T	HE TEMP TANK A	°F	0	+100	10	1	0.4
SR5014T	HE TEMP TANK B	°F	0	+100	10	1	0.4
SR5015T	HE TEMP TANK C	°F	0	+100	10	1	0.4
SR5016T	HE TEMP TANK D	°F	0	+100	10	1	0.4
SR5025Q	QUAN SM RCS PRO SYS A	VDC	0	5	1	1	0.02
SR5026Q	QUAN SM RCS PRO SYS B	VDC	0	5	1	1	0.02
SR5027Q	QUAN SM RCS PRO SYS C	VDC	0	5	1	1	0.02
SR5028Q	QUAN SM RCS PRO SYS D	VDC	0	5	1	1	0.02
SR5065T	TEMP ENGINE PACK- AGE A	°F	0	+300	1	-	1.2
SR5066T	TEMP ENGINE PACK- AGE B	°F	0	+300	1	-	1.2
SR5067T	TEMP ENGINE PACK- AGE C	°F	0	+300	1	-	1.2
SR5068T	TEMP ENGINE PACK- AGE D	°F	0	+300	1	-	1.2
SR5729P	A HE MANIFOLD PRESS	PSIA	0	400	10	1	1.7
SR5733P	OX MANIFOLD PR SYS A	PSIA	0	300	10	-	1.3
SR5737P	FUEL MANIFOLD PR SYS A	PSIA	0	400	10	1	1.7
SR5776P	B HE MANIFOLD PRESS	PSIA	0	400	10	1	1.7
SR5780P	OX MANIFOLD PR SYS B	PSIA	0	300	10	-	1.3
SR5784P	FUEL MANIFOLD PR SYS B	PSIA	0	400	10	1	1.7
SR5817P	C HE MANIFOLD PRESS	PSIA	C	400	10	1	1.7
SR5820P	OX MANIFOLD PR SYS C	PSIA	0	300	10	-	1.3
SR5821P	OX MANIFOLD PR SYS D	PSIA	0	300	10	-	1.3

TABLE B7-II.- COMMAND AND SERVICE MODULE TELEMETRY DATA SUMMARY - Continued.

Measurement					Samples/Second		Units/Count
Number	Title	Unit	Approx. Range		High Bit Rate	Low Bit Rate	
			Low	High			
SR5822P	FUEL MANIFOLD PR SYS C	PSIA	0	400	10	1	1.7
SR5823P	FUEL MANIFOLD PR SYS D	PSIA	0	400	10	1	1.7
SR5830P	D HE MANIFOLD PRESS	PSIA	0	400	10	1	1.7
BS0080X	EDS ABORT REQUEST A		NORM	ABORT	10	1	
BS0081X	EDS ABORT REQUEST B		NORM	ABORT	10	1	
CS0150X	MASTER CAUTION- WARNING ON		WARN/ OFF	NORM	10	1	
LS0200H	ANGLE OF ATTACK	PSID	0	5	10	-	0.017
CS0220T	TEMP DOCKING PROBE	°F	-100	+300	1	-	1.7
CT0012X	DSE TAPE MOTION MONITOR		OFF	MOTION	10	1	
CT0015V	SIG COND POS SUPPLY VOLTS	VDC	0	22	10	1	0.09
CT0016V	SIG COND NEG SUPPLY VOLTS	VDC	-22	0	10	1	0.09
CT0017V	SENSOR EXCITATION 5 VOLTS	VDC	0	5.5	10	1	0.02
CT0018V	SENSOR EXCITATION 10 VOLTS	VDC	0	11.	10	1	0.04
CT0120X	PCM BIT RATE CHANGE 8 BIT		LOW	HIGH	1	1	
CT0125V	PCM HI LEVEL 85 PERCENT REF	VDC	0	+5	10	1	0.02
CT0126V	PCM HI LEVEL 15 PERCENT REF	VDC	0	+5	10	1	0.02
CT0262V	UDL VALIDITY SIG 4-BIT		NA	NA	50	10	
CT0340X	PCM SYNC SOURCE EXT OR INT		INT	EXT	10	-	
CT0620E	S-BAND REC 1-2 AGC VOLTAGE	COUNTS	1	254	10	1	1 - NL
CT0640F	S-BAND RCVR 1-2 STATIC PH ERR	COUNTS	1	254	10	-	1 - NL
ST0820K	PROTON COUNT RATE CHANNEL 1	KHz	0	100	10	-	0.015 - NL
ST0821K	PROTON COUNT RATE CHANNEL 2	KHz	0	10	10	-	0.0015 - NL
ST0822K	PROTON COUNT RATE CHANNEL 3	KHz	0	10	10	-	0.0015 - NL
ST0823K	PROTON COUNT RATE CHANNEL 4	KHz	0	10	10	-	0.0015 - NL
ST0830K	ALPHA COUNT RATE CHANNEL 1	KHz	0	10	10	-	0.0016 - NL
ST0831K	ALPHA COUNT RATE CHANNEL 2	KHz	0	10	10	-	0.0015 - NL

TABLE B7-II.- COMMAND AND SERVICE MODULE TELEMETRY DATA SUMMARY - Concluded.

Measurement					Samples/Second		Units/Count
Number	Title	Unit	Approx. Range		High Bit Rate	Low Bit Rate	
			Low	High			
ST0832K	ALPHA COUNT RATE CHANNEL 3	KHz	0	10	10	-	0.0015 - NL
ST0838K	PROTON-ALPHA INTEGR COUNT RATE	KHz	0	100	10	-	0.015 - NL
ST0840T	TEMP NUCLEAR PAR- TICLE DET	°F	-120	+200	1	-	1.2 - NL
ST0841T	TEMP NUCLEAR PAR- TICLE ANALYZER	°F	-120	+200	1	-	1.2 - NL

NL - Non Linear

MISSION CONTROL

The Flight Director in Mission Control is supported by a team of specialists who are responsible for different aspects of spacecraft operation. These specialists are located in Mission Control and sit in front of console displays which provide real-time telemetry data. Each specialist is in voice contact with a group of support personnel in adjacent rooms who also have access to real-time telemetry data. See Appendix A, Part A⁴ for a description of the organization of Mission Control.

The display console for the CSM Electrical and Environmental Engineer (EECOM) is shown in figure B7-7 and is representative of the type of displays available to all the specialists in the Mission Control Center. The two television monitors on the console are used to display real-time telemetry data. Although various data formats are available to the EECOM, the two displays most frequently in use are shown in figures B7-8 and B7-9. These displays are updated once per second.

As an aid in recognizing out-of-tolerance parameters and spacecraft events, three groups of event indicators are provided at the top of the console. The lights on these panels which alert the EECOM to out-of-tolerance parameters are referred to as limit sense lights. A limit sense light comes on whenever the parameter in question falls outside of high and low limits which are manually set by the EECOM for that particular parameter. Among the 72 lights on panel 3, there are a total of 12 limit sense lights for pressure, temperature, and quantity in each cryogenic oxygen and hydrogen tank. In normal operation, the EECOM sets fairly tight limits on the limit sense lights in order to get an immediate indication of parameter variations. Consequently, it is not unusual for several limit sense lights to be burning.

Besides the limit sense lights, there are lights which indicate spacecraft events. One of these, located in the upper row of panel 9, indicates the presence of a master caution and warning in the spacecraft.

The following is a list of the system specialists in Mission Control:

(a) Retrofire Officer (RETRO) - responsible for abort planning, deorbit/entry times, and landing point prediction.

(b) Flight Dynamics Officer (FIDO) - responsible for coordinating and participating in mission planning and the control of the trajectory aspects of the mission, including powered flight trajectory, abort, and orbital GO/NO GO decision.

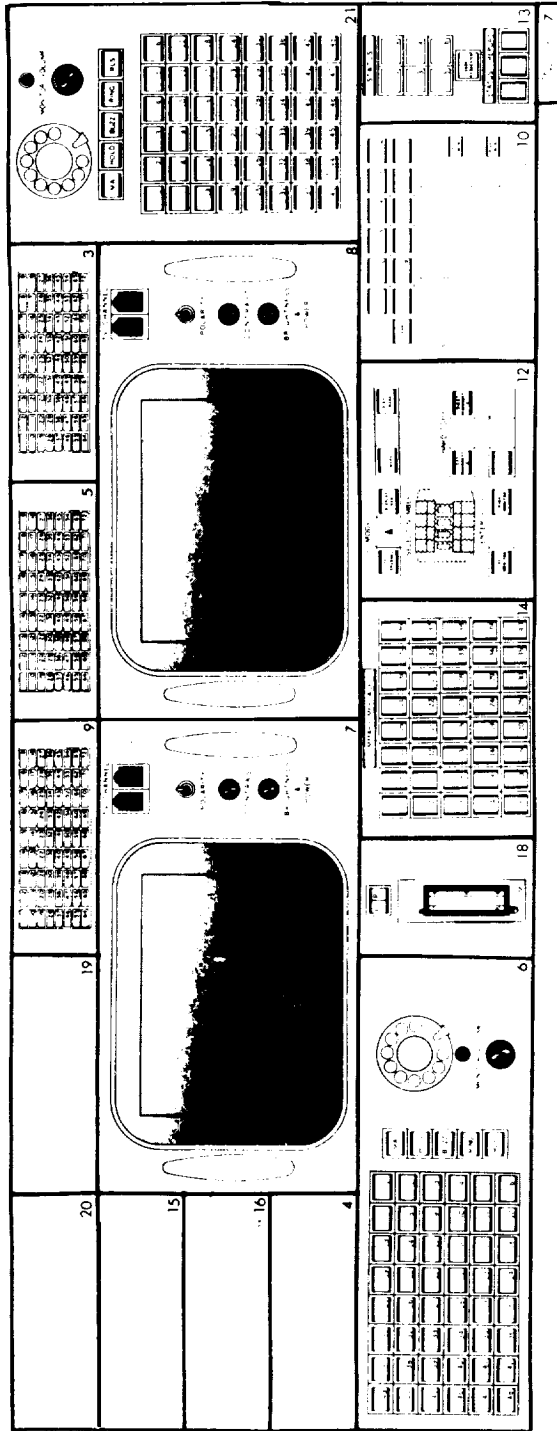

Location	Description	Location	Description
3	Event indicator	10	Display request keyboard
5	Event indicator	12	Manual select keyboard
6	Voice communication position	13	Status/status report
7	Precision TV monitor	14	Summary message inable keyboard
8	Precision TV monitor	18	Analog meter
9	Event indicator	21	Voice communication position

Figure B7-7.- GSM EECOM engineer console.

LM1885

CSM EPS HIGH DENSITY

LM1885

O518

CTE 055:46:51) GET 55:46:53) SITE	
DC VOLTS	AC VOLTS	FC	° F	FC	° F
CC0206 VMA	29.5	CC0200 AC 1	115.6	SC2084 1 SKN	409.1
CC0207 VMB	29.4	CC0203 AC 2	115.7	SC2085 2 SKN	412.7
CC0210 VBA	36.4	FC PSIA		SC2086 3 SKN	414.5
CC0211 VBB	39.5*	SC2060 1 N2	55.8	SC2081 1 TCE	158.0
CC0232 VBR	35.8	SC2061 2 N2	53.9	SC2082 2 TCE	158.9
CD0200 VMLA	0.15	SC2062 3 N2	54.4	SC2083 3 TCE	157.1
CD0201 VMLB	0.15	SC2066 1 O2	64.6	FC RAD	° F
CD0005 VMQA	0.15	SC2067 2 O2	62.7	SC2087 1 OUT	70
CD0006 VMQB	0.15	SC2068 3 O2	63.5	SC2088 2 OUT	71
DC AMPS		SC2069 1 H2	64.7	SC2089 3 OUT	75
TOT SC	67.7	SC2070 2 H2	62.9	SC2090 1 IN	86
TOT FC	67.6	SC2071 3 H2	63.4	SC2091 2 IN	88
FC PCT SC	100.0	1 O2-N2 ΔP	8.8	SC2092 3 IN	95
TOT BAT	0.0	2 O2-N2 ΔP	8.8	- PCT TOTAL FC LOAD	
BAT PCT SC		3 O2-N2 ΔP	9.1	FC 1	31.6
SC2113 FC 1	21.4	1 H2-N2 ΔP	8.9	FC 2	31.6
SC2114 FC 2	21.3	2 H2-N2 ΔP	9.0	FC 3	36.9
SC2115 FC 3	24.9	3 H2-N2 ΔP	9.1	INST	
CC0222 BAT A	0.0	FC LB/HR		CT0120 PCM	HBR
CC0223 BAT B	0.0	SC2139 1 H2	.0659	CT0125 4.25	4.249
CC0224 BAT C	0.0	SC2140 2 H2	.0679	CT0126 0.75	.731
CC0215 CHRGR	1.12*	SC2141 3 H2	.0739	CT0340 TMG	CTE
CC2962 LM	1.6	SC2142 1 O2	0.488	CT0015 +20	20.1
SC2160 PH 1	LOW	SC2143 2 O2	0.507	CT0016 -20	-20.0
SC2161 PH 2	LOW	SC2144 3 O2	0.550	CT0017 +5	5.03
SC2162 PH 3				CT0018 +10	10.1
* Batt B Charging				CT0620 SS	312 *
CC0175/76/77 INV	TMPS	90	88	CS0220 PROBE	(09-54)
		1	2		
		3	73		

Figure B7-8.- Electrical power system parameters display.

LM1839 CSM ECS-CRYO TAB O613

CTE 055:46:51	()	GET 055:46:53	()	SITE
LIFE SUPPORT	PRIMARY COOLANT			
GF3571 LM CABIN P PSIA	CF0019 ACCUM QTY PCT	5.1		34.4
CF0001 CABIN P PSIA	CF0016 PUMP P PSID	4.3		45.0
CF0012 SUIT P PSIA	SF0260 RAD IN T °F	-1.68		73.8
CF0003 SUIT ΔP IN H2O	CF0020 RAD OUT T °F	0.30		35
CF0015 COMP ΔP P PSID	CF0181 EVAP IN T °F	891		45.7
CF0006 SURGE P P PSIA	CF0017 STEAM T °F	3.67		64.9
SURGE QTY LB	CF0034 STEAM P PSIA	21		.161
O2 TK 1 CAP ΔP PSID	CF0018 EVAP OUT T °F	17		44.2
O2 TK 2 CAP ΔP PSID				
CF0036 O2 MAN P PSIA				
CF0035 O2 FLOW LB/HR	SF0266 RAD VLV 1/2	105		ONE
	CF0157 GLY FLO LB/HR	0.181		215
	— SECONDARY COOLANT —			
CF0008 SUIT T °F	CF0072 ACCUM QTY PCT	50.5		36.8
CF0002 CABIN T °F	CF0070 PUMP P PSID	65		9.3
CF0005 CO2 PP MMHG	SF0262 RAD IN T °F	1.5		76.5
H2O	SF0263 RAD OUT T °F			44.6
CF0009 WASTE PCT	CF0073 STEAM P PSIA	24.4		.2460
WASTE LB	CF0071 EVAP OUT T °F	13.7		66.1
CF0010 POTABLE PCT	CF0120 H2O-RES PSIA	104.5		25.8
POTABLE LB	TOTAL FC CUR AMPS	37.6		
CF0460 URINE NOZ T °F		70		
CF0461 H2O NOZ T °F		72		
CRYO SUPPLY	O2-1	O2-2	H2-1	H2-2
SC0037-38-39-40 P PSIA	913	908	225.7 (03-1)	235.1
SC0032-33-30-31 QTY	77.63	01.17	73.24	74.03
SC0041-42-43-44 T °F	-189	-192	-417	-416
QTY	251.1	260.0	20.61	20.83

Figure B7-9.- Cryogenic system display.

(c) Guidance Officer (GUIDO) - responsible for the utilization of the guidance and navigation system, correlation of inertial alignment, and evaluation of terminal phase actions in support of rendezvous.

(d) CSM Electrical, Environmental, and Communications Engineer (EECOM) - responsible for monitoring and evaluating the performance of the electrical power, environmental control, instrumentation, and sequential systems of the command and service modules.

(e) CSM Guidance and Navigation Officer (GNC) - responsible for monitoring and evaluating the performance of the guidance and navigation, propulsion, and stabilization and control systems of the command and service modules.

(f) LM Electrical, Environmental, and EMV Officer (TELMU) - responsible for monitoring and evaluating the performance of the primary guidance and navigation, abort guidance, control electronics, ascent propulsion, descent propulsion, and reaction control systems of the lunar module.

(g) LM Control Officer (CONTROL) - responsible for monitoring and evaluating the performance of the electrical, communications, instrumentation, sequential, and environmental control systems of the lunar module.

(h) Instrumentation and Communication Officer (INCO) - responsible for monitoring and evaluating the performance of spacecraft communications systems.

(i) Procedures Officer (PROCEDURES) - responsible for the detailed procedures implementation of Mission Control.

(j) Flight Activities Officer (FAO) - responsible for the detailed implementation of the flight plan and its revision.

(k) Aeromedical Officer (SURGEON) - directs all operational medical activities concerned with the mission.

The following table lists the members of the White and Black Mission Control teams. The White Team was on duty at the time of the accident, and many of the Black Team members were in Mission Control preparatory to their going on duty about an hour later.

Position	White	Black
Flight Director	E. F. Kranz	G. S. Lunney
Asst. Flt. Dir.	J. M. Leeper	L. W. Keyser
RETRO	B. T. Spencer	T. E. Weichel
FIDO	W. M. Stoval	W. J. Boone
GUIDO	W. E. Fenner	J. G. Renick
EECOM	S. A. Liebergot	W. C. Burton
GNC	B. N. Willoughby	J. A. Kamman
TELMU	R. H. Heselmeyer	W. M. Merritt
CONTROL	L. W. Strimple	H. A. Loden
INCO	G. B. Scott	T. L. Hanchett
PROCEDURES	J. R. Fucci	E. W. Thompson
FAO	E. B. Pippert	T. R. Lindsey
SURGEON	W. R. Hawkins	G. F. Humbert

REFERENCES

1. Anon.: Apollo 13 Mission 5-Day Report. MSC-02429, Manned Spacecraft Center, April 1970.
2. Anon.: Apollo 13 Technical Air-to-Ground Voice Transcription, Manned Spacecraft Center, April 1970.
3. Anon.: Spacecraft Operations for S.V. Countdown/Countdown Demonstration. FO-K-0007-SC109, North American Rockwell Corp., Feb. 5, 1970.
4. Anon.: Mission Director's Summary Report, Apollo 13. Manned Spacecraft Center, April 20, 1970.
5. Anon.: Apollo 13 Mission Operations Report. Manned Spacecraft Center, April 28, 1970.
6. Anon.: Saturn AS-508 M + 5 Day Report. Marshall Space Flight Center, April 22, 1970.
7. Manned Spacecraft Center: Flight Data File. (The complete set of checklists, procedures, activity timeline books, and flight plan carried on board the spacecraft).

NASA — MSC

APPENDIX C
REPORT OF MANUFACTURING
AND TEST PANEL



CONTENTS

Part		Page
	APPENDIX C - REPORT OF MANUFACTURING AND TEST PANEL	
C1	<u>TASK ASSIGNMENT AND IMPLEMENTATION</u>	C-1
C2	<u>ORGANIZATION</u>	C-3
C3	<u>SUMMARY</u>	C-5
C4	<u>REVIEW AND ANALYSIS</u>	C-9
	MANUFACTURE AND ACCEPTANCE TESTING OF THE CRYOGENIC OXYGEN STORAGE TANKS	C-9
	Summary of the Standard Tank Manufacturing Process	C-9
	Acceptance Testing	C-63
	Summary of Significant Aspects of the Manufacture and Acceptance Test of Cryogenic Oxygen Storage Tank Serial No. 10024XTA0008	C-65
	Investigation of Manufacturing Process and Supporting Analysis	C-66
	INTEGRATION, SYSTEM TESTING, AND PRELAUNCH CHECKOUT OF THE CRYOGENIC OXYGEN STORAGE TANKS	C-72
	Summary of Nominal Processes and Procedures	C-72
	Summary of Significant Aspects of Serial No. 0008 Tank Prelaunch Integration Test and Checkout History	C-77
	Investigation and Supporting Work	C-94

This page left blank intentionally.

PART C1

TASK ASSIGNMENT AND IMPLEMENTATION

Panel 2 was assigned the responsibility of reviewing manufacturing and testing associated with spacecraft equipment involved in the flight failure as determined from the review of the flight data and the analysis of the design. In particular, the Panel was to examine discrepancies noted during the fabrication, assembly, and test of components of the oxygen portion of the cryogenic gas storage system within the service module in order to determine any correlations between such preflight discrepancies and the actual inflight events.

Members of the Panel observed actual assembly of an oxygen tank and the oxygen shelf at various stages of assembly at the contractor facilities and reviewed documentation relating to the course of Apollo 13 equipment from manufacturing through test to launch. In addition, the Panel reviewed parts and material qualification data, inspection reports, reliability and quality control records, and preflight test and checkout procedures and results. Throughout the course of its review, Panel 2 concentrated on determining whether manufacturing or test procedures could adversely affect reliable conduct of flight. The steps in the manufacturing and testing of the suspected components were studied so as to evaluate various equipment acceptance procedures. Finally, the Panel attempted to relate observed flight events back to individual points in the manufacturing and testing process in order to determine if any correlation was probable.

This page left blank intentionally.

PART C2

ORGANIZATION

Panel 2 was chaired by Mr. H. M. Schurmeier, Jet Propulsion Laboratory, and the Board Monitor was Dr. J. F. Clark, Goddard Space Flight Center. Panel members were:

Mr. E. F. Baehr, Lewis Research Center
Mr. K. L. Heimburg, Marshall Space Flight Center
Mr. B. T. Morris, Jet Propulsion Laboratory

Specific assignments covering such areas as subsystem testing, fabrication process, and reliability and quality assurance were given to each Panel Member. In reaching Panel conclusions, however, all Members participated in the weighing and evaluation of data.

This page left blank intentionally.

PART C3

SUMMARY

The basic tank provides a thermally isolated pressure vessel structure that is relatively straightforward to manufacture. The manufacturing process has reasonable controls and provides tanks of high structural quality.

The manufacture of the internally mounted equipment is somewhat more complex because of the large number of parts that are required to make these assemblies. The careful use of jigs, fixtures, and the detailed Manufacturing Operations Procedures (MOP) adequately controls these steps and provides hardware fully meeting the structural design requirements as stated on the engineering drawings.

The most noteworthy manufacturability shortcoming of the design is the routing of the wires from the electrical devices within the tank. The passageways are small, adjacent metal corners are relatively sharp, and the condition of the insulation cannot be inspected after assembly. The assembly process is very difficult and even though detailed MOP's are provided and the technicians are skilled and experienced in these operations, the resultant product is of questionable quality because of the many opportunities to damage the insulation on the wires. Even in the assembled condition, the wires can be damaged because of the lack of support and restraint and the exposure to turbulent fluid during tanking, detanking, and purging operations.

Another notable shortcoming of the design is the very loose tolerances specified for the tank fill tube connecting parts. The tolerance range permitted by the engineering drawings can result in a fill tube assembly that can fall out of place if the parts are at or near the low tolerance limits. The parts cannot be assembled if their size averages much larger than nominal. Even with all parts of the fill tube assembly near the nominal sizes specified, adequate diametral clearance exists for a sizable gas leakage path.

The Globe Industries, Inc., fan motors have had a history of numerous problems. Many design changes were introduced to overcome these problems. The most prevalent problem was dielectric breakdown within the stator windings. Process changes and the addition of 300 volts rms phase-to-phase dielectric tests during stator assembly greatly reduced the incidence rate of this problem.

The standard acceptance procedures adequately cover all functional requirements for normal flight use but do not check the ability of the heater thermostats (thermostatic switches) to function under load,

nor do they state a requirement for proper functioning of the fill tube assembly, which must function as a dip tube during detanking operations.

The manufacturing history of tank no. 2 of Service Module 109 (10024XTA0008) before delivery from Beech was unusual only to the extent that the tank was reworked twice after initial closure, once to replace a heater tube assembly including both motor fans and once to replace pinch-off tube assemblies used in evacuation of the annulus volume between the tank shells.

The test history was unusual only to the extent that the high but acceptable heat leak characteristic caused months of delay in tank acceptance. No direct evidence of any particular characteristic of this tank at delivery from Beech, as distinguished from any other Block II oxygen tank, was found that would correlate with the Apollo 13 flight accident.

The normal procedure at the conclusion of the heat leak tests at Beech Aircraft Corporation, Boulder, Colorado, calls for expelling the last 25 pounds of the remaining liquid oxygen through the "fill" line by applying pressure to the vent line with gaseous nitrogen. Although the tank assembly is on a weighing system which has a resolution of 0.3 pound, and the procedure calls for continuing the application of vent line pressure until both the weighing system and quantity probe indicate the tank is empty, no data were recorded that verify that remaining oxygen was expelled as a liquid. At the time no one indicated that the response of the tank to the procedures was anything but normal, and today careful review of existing data, discussions with the responsible Beech Aircraft and North American Rockwell personnel, and a special test at Beech Aircraft indicates that the detanking of the 0008 tank was most probably normal.

The manufacturing and test procedures and activities for integrating the oxygen storage tanks into the service module were thoroughly detailed and closely monitored with respect to procedures. They involved checkouts with dry gas only, until cryogenic oxygen reaches the tanks during the countdown demonstration test (CDDT) at Kennedy Space Center (KSC) a few weeks before launch. Between the tank acceptance and CDDT only pressure vessel integrity and electrically observable phenomena of the inner tank elements are tested. No tests are performed to check the ability of the thermostats to interrupt either the spacecraft-supplied heater power (about 2.8 amps at 28 V dc) or the GSE power (about 6 amps at 65 V dc).

In August 1968, oxygen shelf assemblies at North American Rockwell (NR), Downey, were scheduled to be modified to add potting to the dc-to-dc converters of oxygen tank vent-ion pumps for electromagnetic interference prevention. During factory procedures with the oxygen

shelf assembly incorporating tank 10024XTA0008 in the tank no. 2 position in Service Module 106 at NR, Downey, a handling fixture incident (initiated by failure to remove an unnoticed shelf bolt) subjected this tank to unexpected jolts. These included the apparent shelf damaging contact of the tank with the fuel cell shelf and drop of the tank with the shelf to the normal oxygen mounts. Such elements as the fill tube segments appear vulnerable to this incident. No record of investigation into the internal condition of the tank other than pressure and electrical circuit test could be found. Manufacturing and test records do not show engineering assistance related to conditions internal to the oxygen storage tank.

Service Module 106 was promptly repaired and fitted with a different oxygen shelf already modified (ultimately it flew as Apollo 10). The tank and the oxygen shelf now under review were re-inspected and retested during the first 3 weeks of November 1968. They were then installed in Service Module 109 (used in the Apollo 13 flight). This service module was completed, tested, and checked out normally thereafter, so far as the oxygen system was concerned, and transported to KSC in mid-1969.

During integrated test and checkout at KSC, no major anomaly occurred until the tank-emptying phase of the CDDT, March 23, 1970. After this first cryogenic oxygen loading since February 1967, expulsion of liquid oxygen through the "fill" line under gas pressure applied through the vent line was not achieved. Evidence supporting the assumptions of leakage or dislodgment of the fill line segments (two Teflon elbows and one short Inconel tube) in the top of the quantity probe assembly within the oxygen tank was produced at KSC in the processes of emptying the tank.

Special methods used for emptying on March 27 and 28, 1970, and again on March 30, involved protracted operation of the tank heaters and fans for many hours and at maximum heater voltage. In conjunction with this heating, cyclic gas pressurization and blowdown was used to achieve rapid boiling to remove oxygen from the tank. Analyses of data taken during the early portion of these procedures confirm boiling as sufficient to detank the observed quantities.

These methods were not supported by previous comparable operations with any other Apollo CSM cryogenic oxygen storage tank. Thus it was not demonstrated separately that such operation could be accomplished without degradation or hazard in the subsequent flight use of the tank.

A review of all the evidence available indicates that this tank (at least the fill line segments) most probably arrived at the CDDT in a different condition than that in which it was last tested at Beech Aircraft Corporation.

Tests were conducted at the Manned Spacecraft Center to evaluate the effects of the sustained heater operation during the special detanking operation at KSC on March 27, 1970. These tests demonstrated that the thermostats would weld closed when they attempted to interrupt the 5.9 amps, 65 volts dc GSE power (a condition for which they were neither designed nor qualified) resulting in their failing to limit the temperature inside the tank. The tests also showed that with the heaters on continuously and as the cryogenic liquid boiled away, temperatures in the 700° to 1000° F range would exist on portions of the heater tube in contact with the motor wires. These temperatures severely damaged the Teflon insulation even in the nitrogen atmosphere of these tests. Small-scale tests subjecting Teflon insulated wires to 700° to 1000° F temperature oxygen atmosphere indicated even more severe damage to the Teflon insulation.

Therefore it is reasonable to conclude that the special detanking procedures employed on tank 0008 at KSC prior to launch of Apollo 13 severely damaged the insulation of the motor wiring inside the tank.

A more complete test is being conducted at Beech Aircraft, Boulder, Colorado, to simulate the special detanking operations used at KSC on March 27-28 and 30, 1970. This test will utilize a flight configuration tank, simulated KSC ground support equipment, and will be conducted using oxygen.

PART C-4

REVIEW AND ANALYSIS

MANUFACTURE AND ACCEPTANCE TESTING
OF THE CRYOGENIC OXYGEN STORAGE TANKS

The cryogenic oxygen storage tanks are manufactured by the Beech Aircraft Corporation, Boulder Division, located north of Boulder, Colorado. The tank consists of a spherical high-pressure inner vessel wrapped with multilayer insulation contained within a thin external metal vacuum jacket. Inside the pressure vessel are a heater and fan assembly (two heaters and two fans), a quantity measuring probe, and a temperature sensor. Many of the parts and subassemblies that comprise this tank are purchased by Beech from subcontractors and vendors located throughout the United States.

The detailed instructions for the manufacture and assembly of these tanks and their subassemblies at Beech are controlled by Manufacturing Operations Procedures (MOP). In addition to instructing the technicians, the MOP also calls out the presence and activities of the inspectors.

Summary of the Standard Tank Manufacturing Process

The inner pressure vessel is made from two forged hemispheres of Inconel 718 alloy. The rough-machined heat-treated forgings are supplied by the Cameron Iron Works, Houston, Texas. The physical, chemical, and metallurgical properties (X-ray, ultrasonic scan, and microstructure) of these forgings are tested and certified by Cameron. The Airite Division of Electrodata Corp., Los Angeles, California, does the final machining and electron beam welding. Prior to welding a very thorough inspection is made of each hemisphere. About 430 thickness checks are made to assure compliance to dimensional accuracy requirements. Each hemisphere is thoroughly X-rayed and dye-penetrant inspected for defects. The internal parts that support the heater probe assembly are made by Beech and supplied to Airite for installation prior to making the electron beam equatorial weld. A rather elaborate five-step welding process is used in making this equatorial weld (figs. C4-1 and C4-2). The first step is a series of tack welds. The second step is a seal weld of shallow penetration. The third step is a deep-penetration weld. The fourth step is a shallower and wider weld to blend surfaces. The fifth weld is called a cover pass which is still wider and shallower for final surface blending. The completed vessel is X-rayed and then pressure tested. A hydrostatic proof pressure of 1357 psig $\begin{matrix} +00 \\ -35 \end{matrix}$ is applied for 3 minutes using water. The volumetric expansion during the proof-pressure test is determined by measuring the weight increase of water contained within the test specimen. A leak test

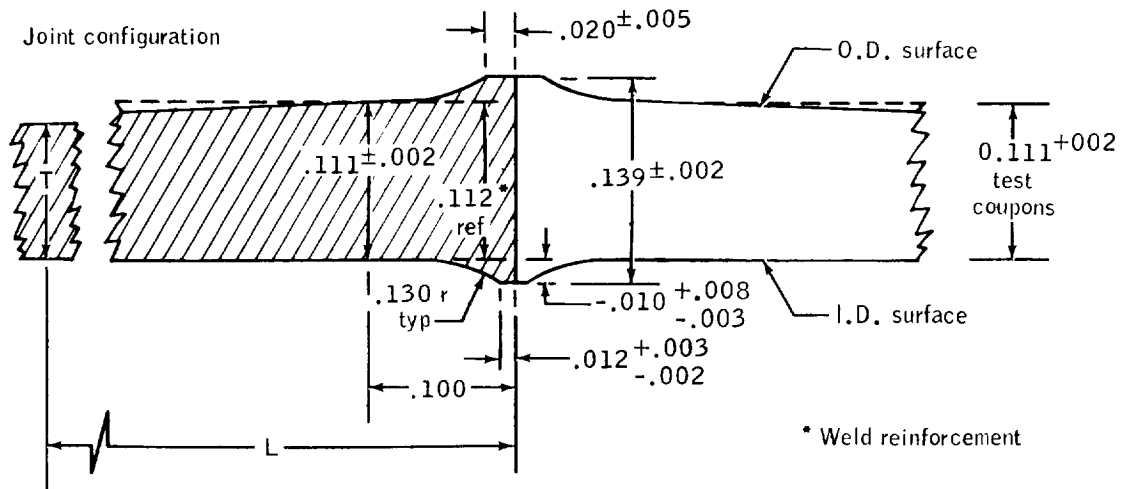

P/M thickness	Tank radius		Dimensions		
	L	T	O.D.	I.D.	
1.000	.084 ± .002	14.808 ref _{arc}	12.528 +.005 / -0	Sph rad	
2.000	.067 ± .002	14.808 ref _{arc}	12.528 +.005 / -0	Sph rad	
3.000	.059 + .004 / - .000	12.587 ref _{arc}	12.528 +.005 / -0	Sph rad	

Weld schedule (Electron beam weld)

Parameter	Pass sequence				
	1-tack	2-seal	3-pene.1	4-pene.2	5-cover
Voltage - Kv	80	80	115	95	85
Amperes - MA	1.5	1.5	6.0	4.0	3.0
Beam deflection - in.	0.012	0.012	.024/.036	.040/.080	0.110
Travel - in./min	18	→	→	→	→
Vacuum - mm hg	2×10 ⁻⁴	→	→	→	→

- Notes: (1) 0.002" gap, 0.003" offset (max typ)
 (2) No weld repairs allowed
 (3) Typical weld sequence shown on attached sketch

Figure C4-1.- Girth weld joint configuration and schedule.

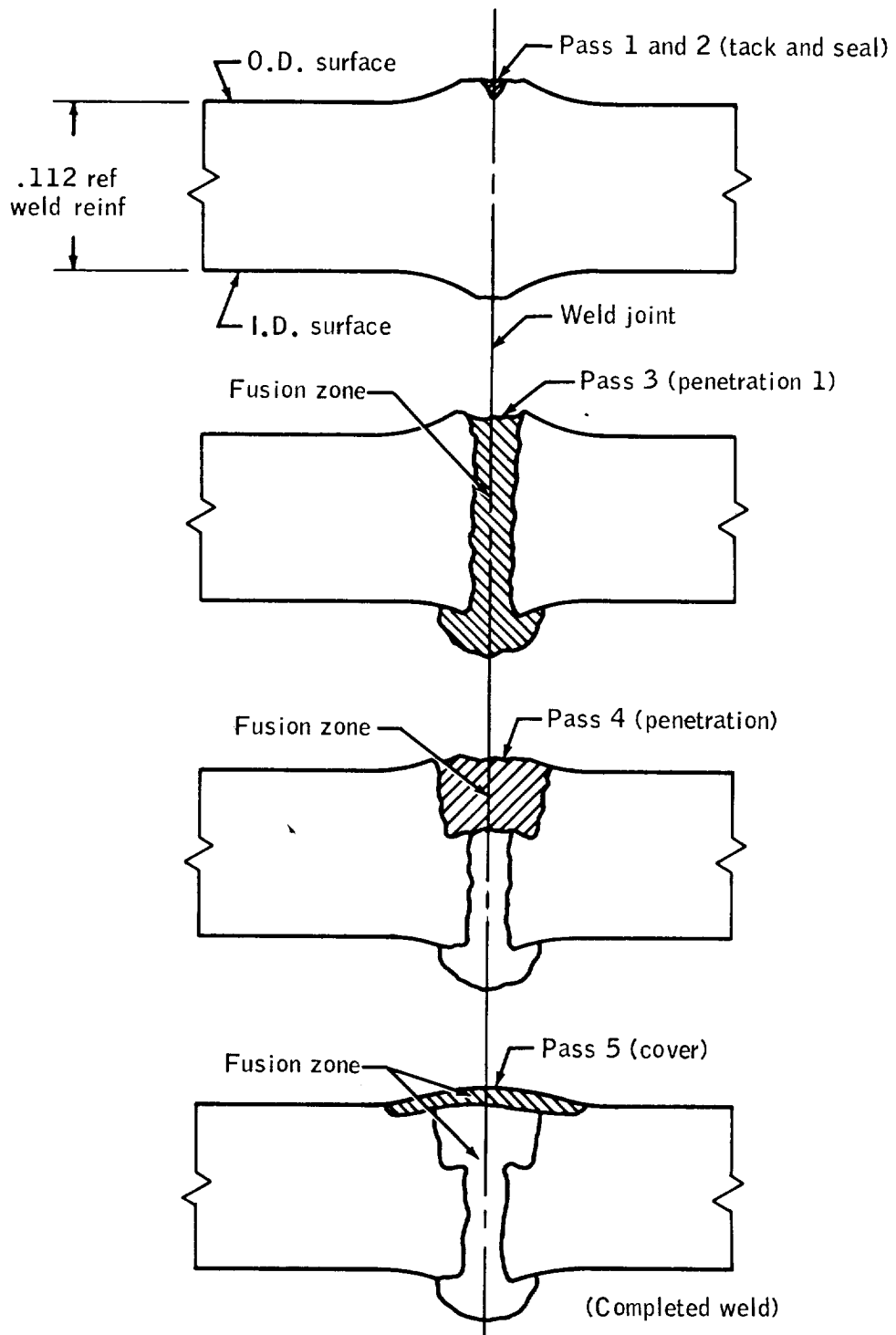

Figure C4-2.- Weld sequence.

is made at 925 psig ± 15 using helium. These tests are performed by the Beech Test Department before acceptance. The completed vessels, along with substantiating data, are shipped to Beech for assembly.

The inner pressure vessel is cleaned for oxygen service and sealed in plastic. When scheduled for application of insulation, the vessel, the insulation, and the other necessary piece parts and supplies are moved to a small room annex to an area known as the Respectable Room. (The Respectable Room, its annexes, and the Ultra Clean Room together are known as the Apollo Assembly Area.)

All assembly operations performed in these rooms are in accord with standard clean room techniques, i.e., lint-free gowns, caps, and gloves. A simple entrance airlock has a motorized shoe brush and vacuum cleaner but the brushes are disabled so as not to rotate under motor power. There is no air scrub.

The insulation is applied to the inner vessel in gore panels, a layer at a time. The insulation consists of many layers of Dexiglas Insulation paper (C. H. Dextar & Son, Inc.), fiberglass, mats, aluminum foil, and aluminized Mylar. Each layer is carefully applied to the vessel, temporarily held in place with tape, trimmed for fit, and then finally held in place by thin nylon threads. After the threads are in place the tape is removed. The joints in succeeding layers are shifted so as to effectively block the flow of heat. The aluminum foil layers are checked with an ohmmeter to assure no electrical contact with inner vessel or adjacent foil layers. About halfway through the insulation process, a tube is installed which goes from the vacuum dome area to the equator, around the equator, and back to the dome area. This is called the vapor cool shield (VCS). (See fig. C4-3.)

After all the insulation is applied, the external metal jacket is installed. These parts are made by Chemtronics, Inc. The main upper and lower hemispheres are deep drawn and chem-milled. The equatorial flange is machined from a ring forging (fig. C4-4). All parts are made of Inconel 750 alloy. An assembly of the lower hemisphere and equatorial flange is made by Heli-arc welding. A shield is placed over the insulation in the region of the final closure weld between the lower hemisphere-flange assembly and the upper hemisphere shell. After these parts are positioned over the insulated pressure vessel, the circumferential weld to join them is made by the automatic Heli-arc welding process using argon gas for inerting the weld zone. The welds in the vacuum jacket are then X-ray inspected to insure integrity.

Figure C4-5 shows the major subassemblies required to complete the oxygen tank assembly. All components and piece parts required to build subassemblies are cleaned for liquid oxygen service, grouped as required

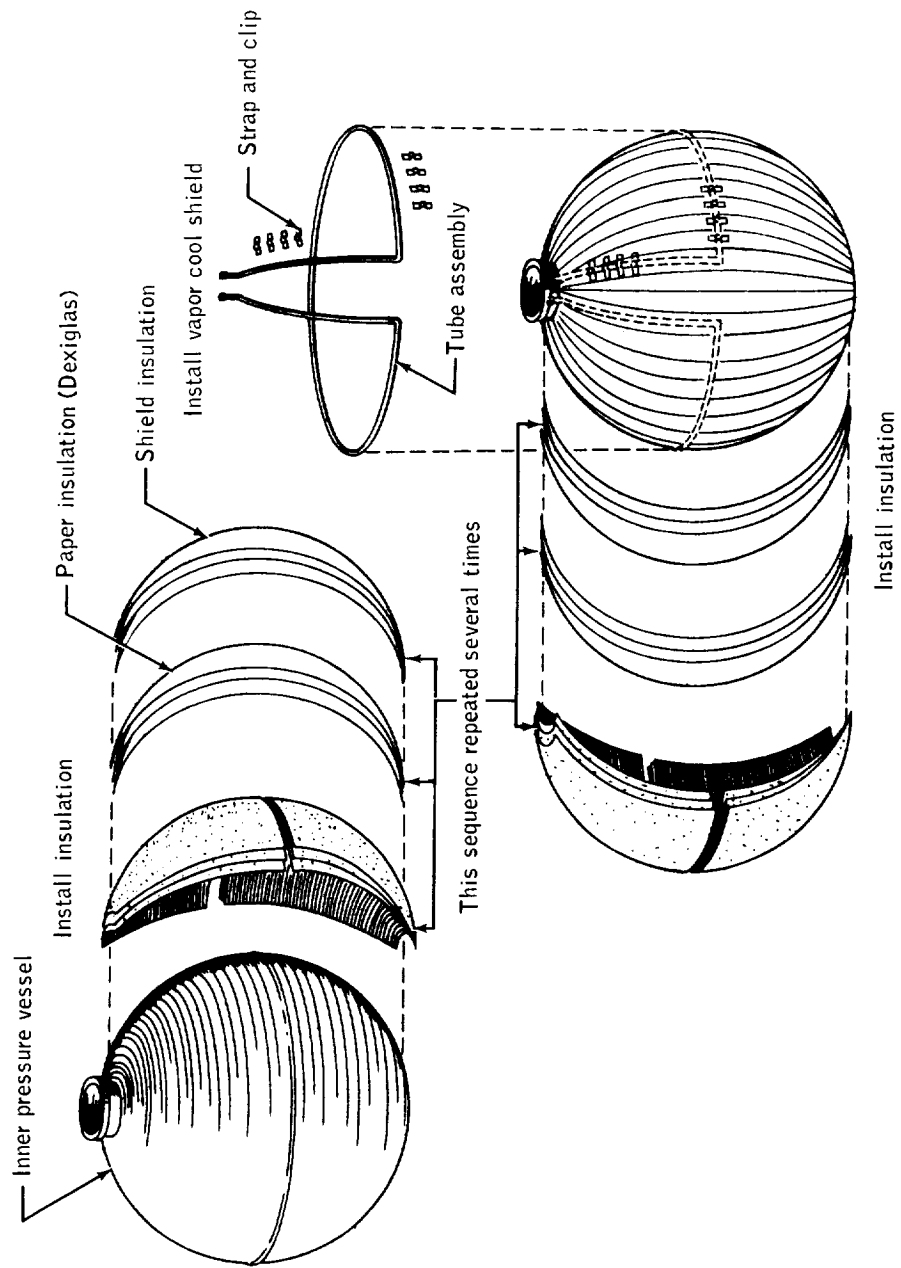

Figure C4-3.- Installation of insulation.

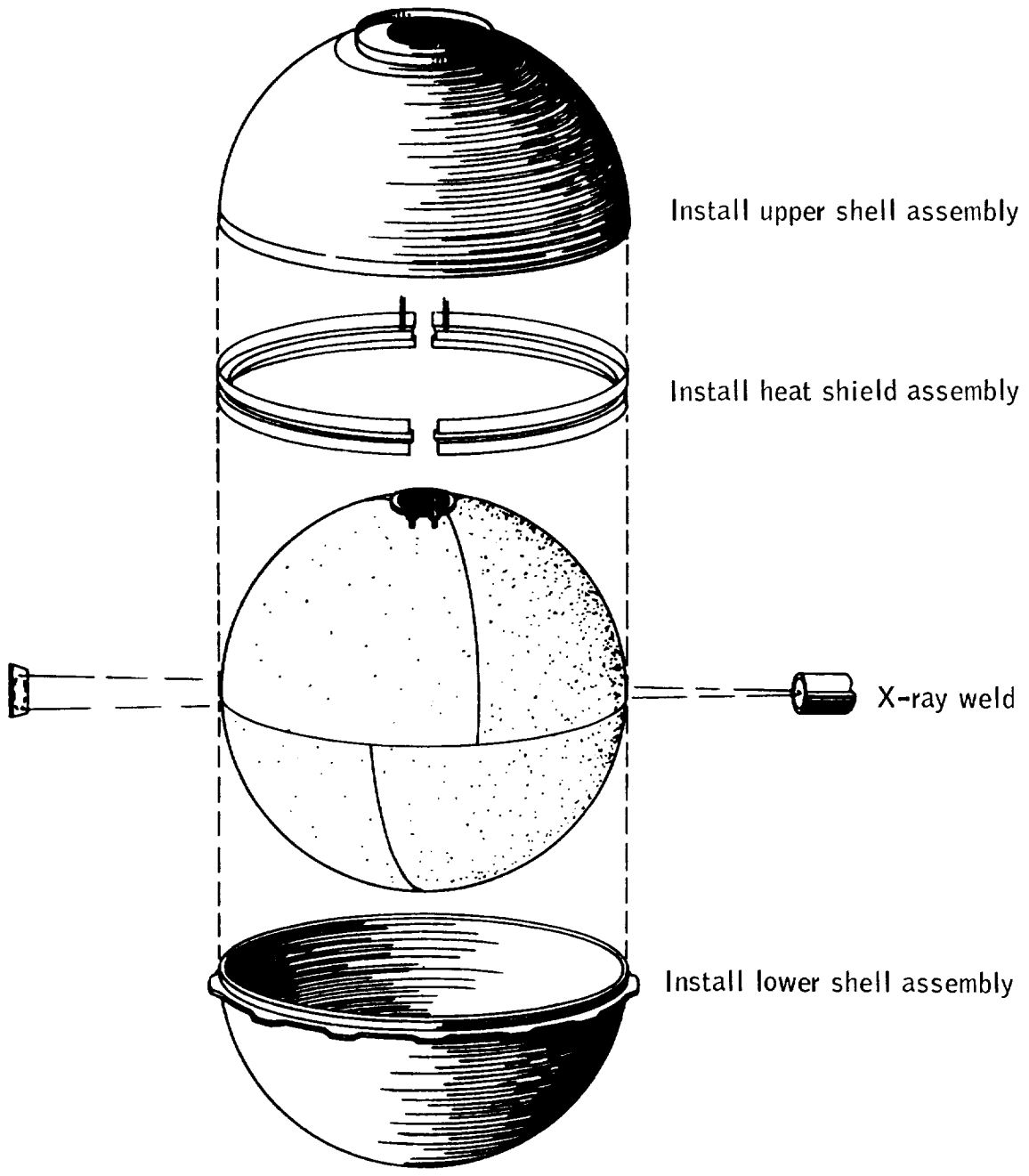

Figure C4-4.- Installation of vacuum jacket.

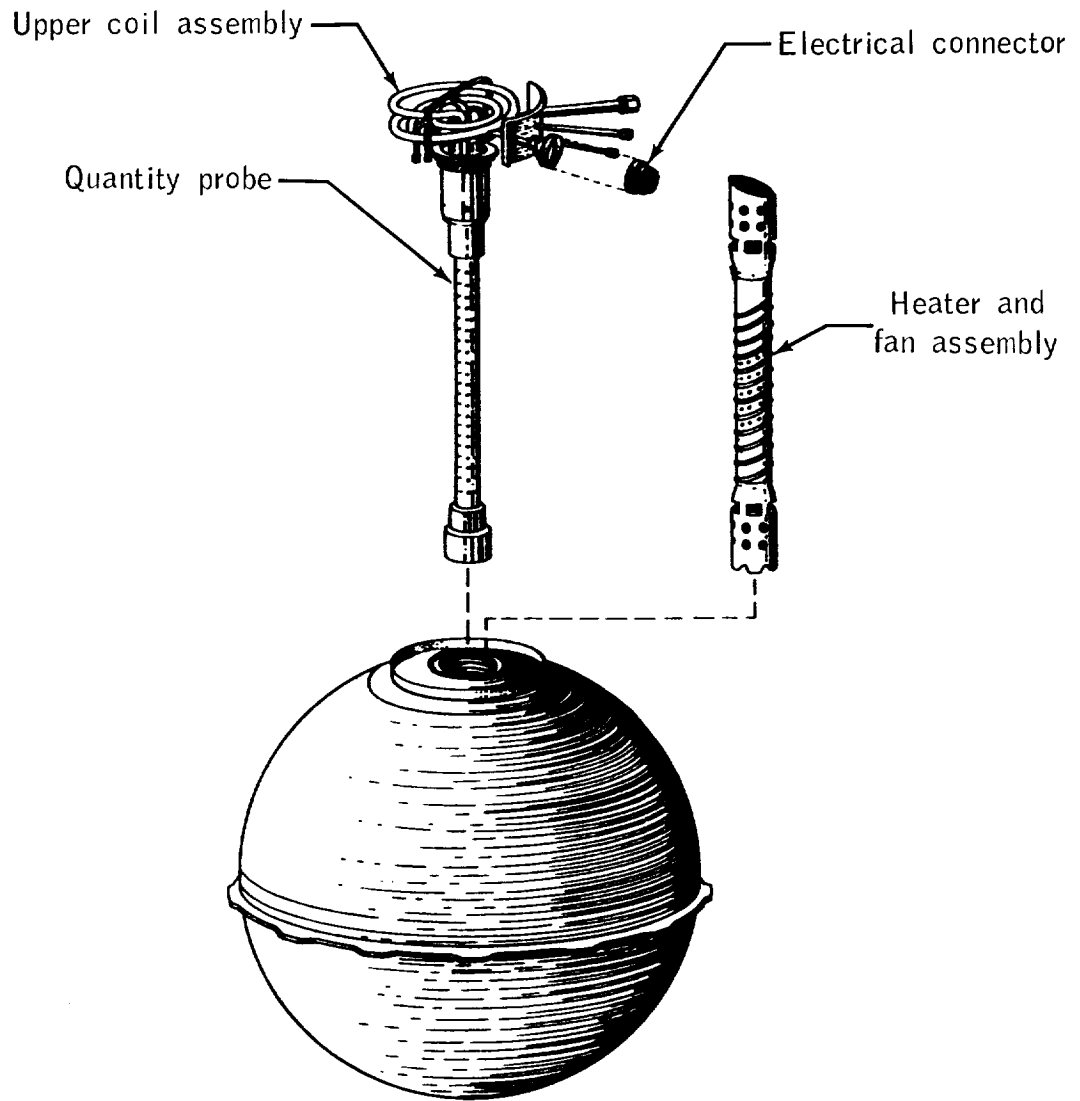

Figure C4-5.- Major subassemblies required for tank assembly.

for each subassembly (kitted), and sealed in a clear nylon plastic bag which is then sealed in a clear polyethylene bag. These kits are stored for the subassembly and assembly operations which are performed in various rooms of the Apollo Assembly Area.

The heater and fan assembly is made from numerous small parts welded, brazed, riveted, or bolted together (fig. C4-6). The first operation installs the lower pump nozzle assembly into the lower motor housing. These parts are positioned in a jig and then fusion welded in place. After this weld is X-rayed, the part is turned to trim the inside diameter and to assure roundness. The lower motor housing is then positioned and welded to the central tube. The weld zone is X-rayed and the entire assembly is pickled and passivated. The two helically preformed stainless-tube-encased nichrome heating elements are then slid in place. Before proceeding the heaters are tested for resistance and isolation from ground. The upper motor housing tube is then positioned and welded to the central heater tube. After this weld is X-rayed, the heaters are positioned and silver soldered in position. After the heater tube is thoroughly cleaned to remove any silver solder flux, the tube (conduit) that routes the wires from the lower motor past the heater elements is installed by riveting the two small clips to the inside of the central tube. Small aluminum shims are riveted to the inner surface of the heater tube to provide a flat surface for the mounting of the thermostats. The unit is then vacuum baked at 200° F to remove any moisture from the heater assembly. The resistance and insulation tests are again run to assure that the brazing has not damaged the heaters and that the units are thoroughly dry.

At this point the heater tube is ready for the installation of the thermostats. The thermostats are purchased from the Spencer Thermostat Division of Metals and Controls, Inc., Attleboro, Massachusetts. Each thermostat is subjected to detailed acceptance testing by Metals and Controls, Inc., and these data are supplied to Beech with the serialized switches. The acceptance testing consists of a 1000 V ac dielectric test for 1 minute, a visual check for workmanship, a dimensional check to drawing size callouts, a 5-minute soak in liquid nitrogen, the opening temperature, the closing temperature, a second 5-minute soak in liquid nitrogen, a recheck of the opening temperature, a recheck of the closing temperature, a leak test to check hermetic seal, a megohm test, the final inspection marking, a recording of number of cycles on the unit as shipped, the actual weight of unit, and visual packing and shipping inspection. Throughout all testing by Metal and Controls, the thermostats are checked by using 6.5 V ac and a small lamp drawing approximately 100 milliamps. Incoming inspection at Beech is limited to a visual examination.

The thermostats are inserted into the tube with their hook-type terminals extending to the outside of the heater tube and bolted in place. This heater tube assembly is then cleaned and bagged for future assembly operations.

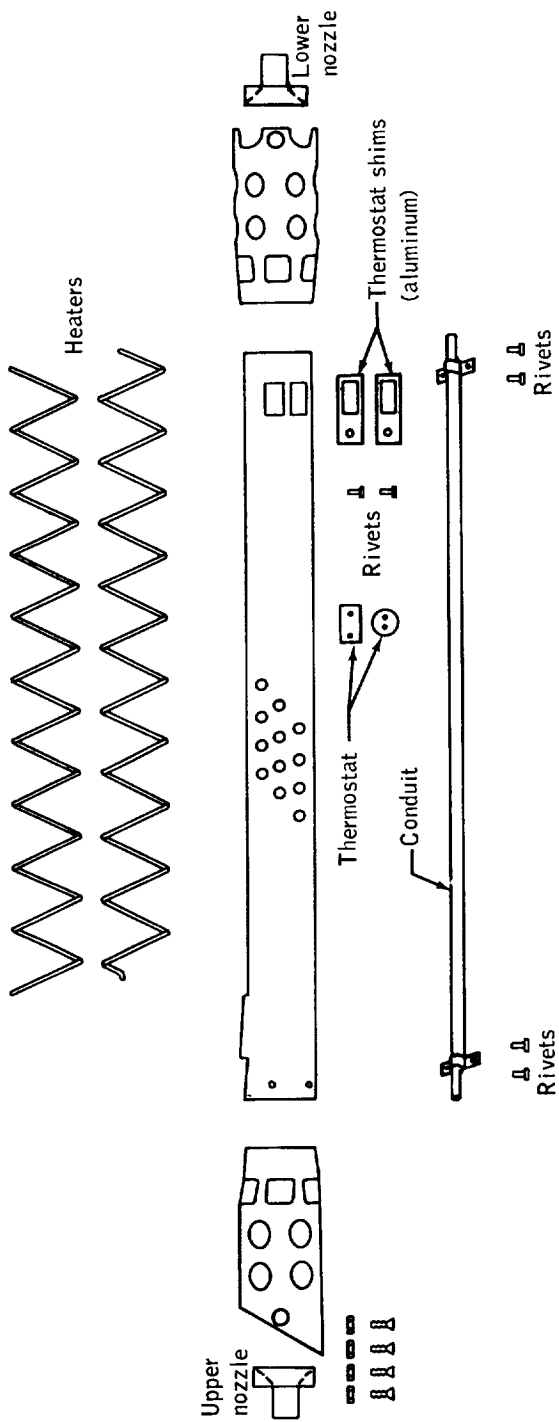

Figure C4-6.- Heater tube assembly.

The electric motor fans are purchased from Globe Industries, Inc. These motors go through a thorough acceptance test at Globe before delivery to Beech. In addition to the normal visual and mechanical inspection, the motors are functionally tested at both ambient and cryogenic conditions. A 1000 V dc dielectric strength test is applied between the windings and case. The isolation must be at least 2 megohms. The motor is then operated on 115 V ac 400 cycles, and the following characteristics are measured and recorded: (1) speed and current of motor when operating with a calibrated test fan, and (2) line current and total power both running and still. The motors are then operated in liquid nitrogen. These checks are limited to assuring that the motor starts and runs smoothly and that coastdown time is at least 30 seconds.

At Beech the normal visual incoming inspection was performed and then these parts were stored until ready to be incorporated into the heater and fan assembly.

The kits of parts and components required for the heater and fan assembly are moved to an annex room of the Respectable Area where this assembly operation is performed on a laminar flow bench. The necessary tools are cleaned and laid out for ease in the assembly process. An assembly aid is used to support the fan and heater tube in the horizontal position.

The lower electric motor is now installed. The electrical leads are provided by the motor supplier (four 26-gage nickel with Teflon insulation twisted 10 turns to the foot with a 2-inch-long Teflon sleeve adjacent to the motor) (fig. C4-7). These leads are routed parallel to the motor shaft through a shallow groove milled half in the motor end cap and half in the motor support tube (figs. C4-8 and C4-9). From this channel the wires are routed against the inner surface of the motor tube in the region of the impeller. The wires then emerge through a hole in the motor housing tube (ungrommeted). The motor is inserted in the end of the tube (fig. C4-10) and the motor end plate is installed. Shims are used as required under this motor end cap to provide 0.030-inch to 0.040-inch end clearance between the impeller and the nozzle. When the proper shims are selected and installed, the four end cap screws are torqued to the required value (fig. C4-11). The end cap is bolted to the support tube by four radial countersunk machine bolts, small segment-shaped shims, and self-locking nuts (all metal).

When the location of the lower motor is verified as having the correct impeller-to-nozzle clearance, the wire routing task continues. The wires travel axially about 2 inches (fig. C4-12) where they go in-board through a Teflon grommet into the inner conduit and travel the length of the heater section to a symmetrical location where they again emerge to the exterior through a Teflon grommet. A single insulated wire is used to pull the motor leads through this conduit route.

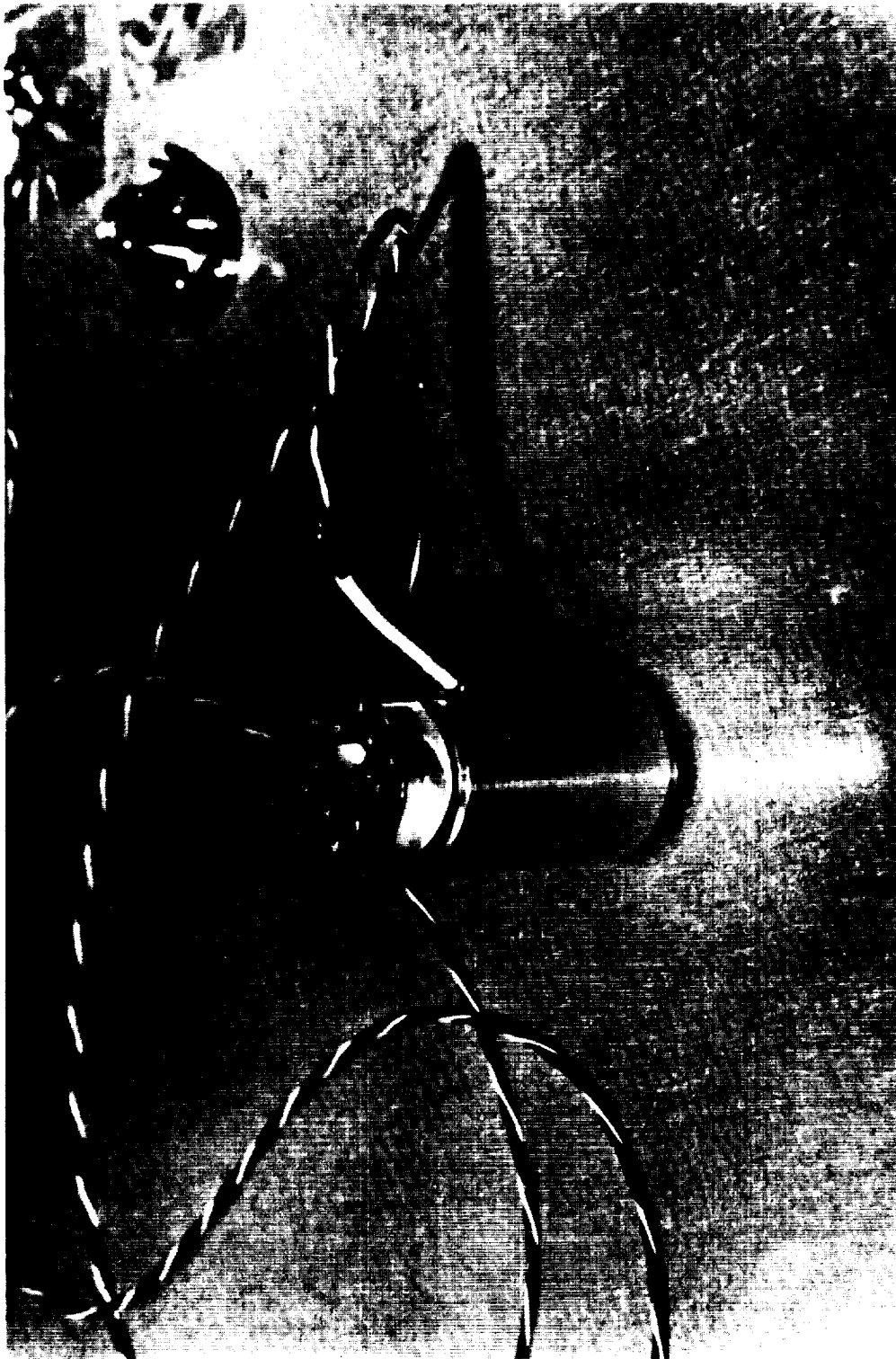

Figure C4-7.- Motor fan with long lead wires.



Figure C4-8.- Installing motor lead wires.



Figure C4-9.- Installing lower fan motor.



Figure C4-10.- Installing lower fan motor showing wire routing.



Figure C4-11.- Tightening the motor end cap bolts to establish the proper torque.



Figure C4-12.- Installing lower motor lead wires in heater conduit.

The installation of the upper motor follows the same general sequence except that once the leads emerge from the tube they do not reenter the heater tube but remain as a twisted bundle of four wires encased in a Teflon sleeve.

Next a small copper band is formed around the upper and lower motor wire bundles in the areas where the impellers of the fans are located to assure that the wires maintain the required clearance with the impellers (approximately 0.030 inch) (figs. C4-13 and C4-14). The ends of these bands are sweat soldered together to retain the wires. The motor leads external to the heater tube are then encased in Teflon shrink tubing. White tubing is used for the lower motor leads and clear tubing is used for the upper motor leads.

The leads are then installed for the heaters. One wire from each heater is soldered to its thermostat. The lead wires (20-gage silver-plated copper with Teflon insulation) are soldered, one to the other terminal of the thermostat and the other wire to the second lead of the nichrome heater element. Separate leads (four total; two for each heater) are provided to extend to the electrical connector fitted outside the dome at the top of the vacuum jacket. Again a cleaning operation is performed to remove any solder flux. Standard 60-percent tin and 40-percent lead solder is used for all electrical connections.

The entire heater and fan probe assembly is subjected to a detailed component acceptance test to assure proper operation. The unit is placed in a controllable temperature oven. Starting from about 100° F, the oven temperature is slowly lowered until the closing of each heater thermostat is noted by means of a Wheatstone bridge. While in this closed position, the resistance value of each heater element is measured and recorded. The oven temperature is then slowly raised to detect the opening temperature for each thermostat. With the unit removed from the oven, the resistance value of each motor winding is measured and recorded. The heaters and motors are subjected to a dielectric strength test at 500 V dc with a maximum allowable leakage current of 0.25 milliamps permitted. The insulation resistance of both heaters and both motors is measured and must indicate a minimum of 2 megohms isolation. The proper operation of the motors is verified in two vertical orientations at full voltage and at two vertical and one horizontal orientations at reduced voltage (80 ± 2 V ac). The time in tenths of hours and number of motor starts are recorded for each test sequence and this is added to the previous history for continuity. The entire assembly is then cleaned for liquid oxygen service, bagged, and stored for future use.

The upper coil assembly as shown on figure C4-5 consists of five coiled tubes to provide the necessary resistance in the heat flow path, an adapter to fit the tank neck, a seal-off plate for the side of the coil housing (vacuum dome), end fittings for the feed lines (that connect



Figure C4-13.- Inserted copper band to retain motor wires.



Figure C4-14.- Forming copper band to retain motor wires.

to the vapor cool shield), and a connector adapter fitting. These tubes are formed by a subcontractor in Denver. The material for all tubes is Inconel 750. All bending is performed using a flexible chain mandrel of Ampco bronze and Ucon lubricant (water soluble). The various piece parts are carefully cleaned and jigged for Heli-arc welding into an assembly. The supply line filter is installed and safety wired. The assembly is X-rayed, recleaned, and bagged for future use.

The quantity probe is a purchased item which is procured from Simmonds Precision complete with leads and temperature sensor installed with leads attached (fig. C4-15). This unit is made of two concentric aluminum tubes for the capacitance-type quantity (density) probe with Teflon spacer buttons located in drilled holes in the inner tube to provide centering action. The lower ends of the concentric tubes terminate in a glass-filled Teflon bushing. This bushing acts as a lower pilot support and also provides a nonconducting extension of the inner tube which is also utilized as a dip tube for the filling and detanking operations. The axial relationship of the inner and outer aluminum tubes is controlled by a single rivet installed through Teflon bushings near the upper end of the assembly.

The upper end of the outer aluminum tube is supported in a large glass-filled Teflon bushing which is riveted to an Inconel tube for final support to the tank adapter. This upper bushing has two axial holes to provide routing for the motor and heater leads. The temperature sensing element is mounted on the side of this bushing. Axially aligned pins through two 0.44-inch cross-drilled holes are used as junction points between the short leads from the temperature sensor and the 48-inch-long extension leads. Two 22-gage wires are used for each extension lead of the sensor (a total of four wires). The capacitance element leads consist of a shielded 20-gage wire for the inner tube and an unshielded 20-gage wire for the outer. Two channel-shaped clips are riveted to the upper ends of the aluminum tubes to solder the lead wires on. The quantity sensor leads are encased in a clear Teflon shrink sleeve. The temperature sensor leads are encased in a separate clear Teflon shrink sleeve. All solder joints are made with 60-percent tin, 40-percent lead solder.

After incoming inspection of this Simmonds-manufactured assembly verifies conformance to the purchase specifications, the unit is cleaned for liquid oxygen service, bagged, and stored for future use.

The parts required for the complete assembly of the quantity probe are then drawn from storage. The first operation is the installation of two insulated pull wires through the holes provided in the quantity probe to route the heater and motor leads. The quantity probe wires, temperature sensor wires, and two pull wires are pulled through the electrical conduit by first pushing a single wire through. All wires are attached to this pull wire to be pulled into the conduit (figs. C4-16 through C4-19). The

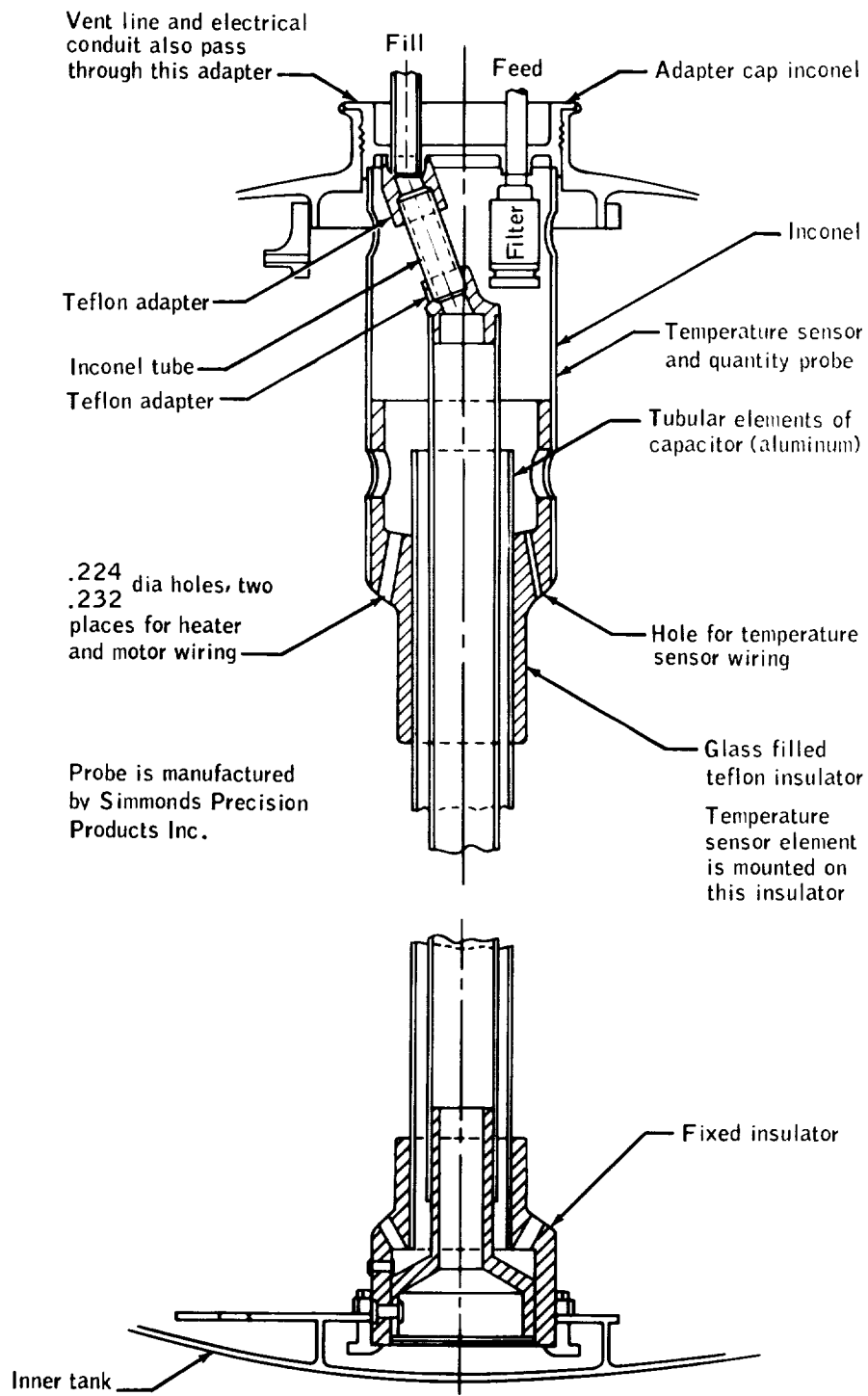

Figure C4-15.- Cross section of quantity probe.



Figure C4-16.- Pulling quantity probe wires into upper coil assembly.



Figure C4-17.- Feeding quantity probe wires
into upper coil assembly.



Figure C4-18.- View showing the feeding and pulling used to install wires.

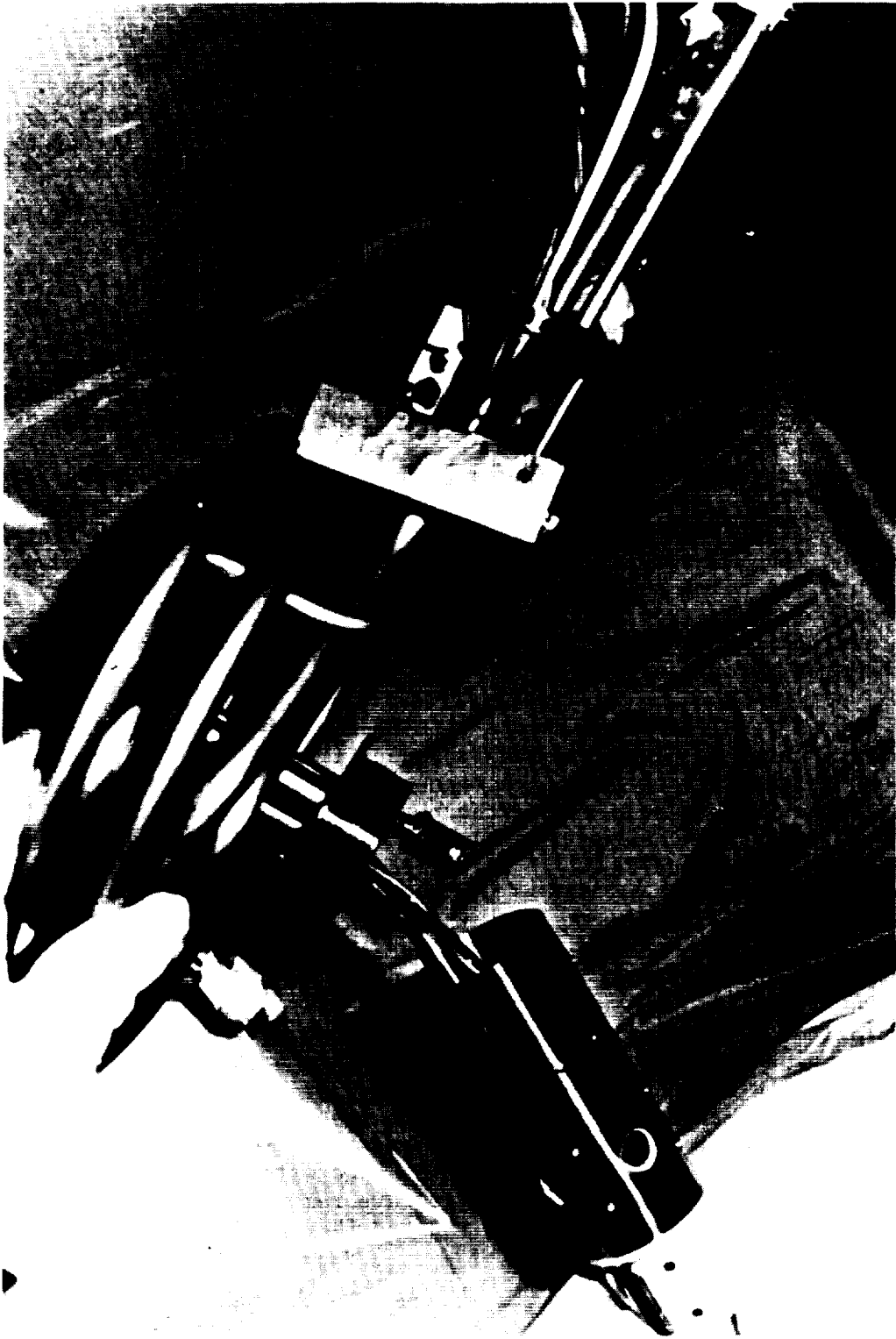

Figure C4-19.- Quantity probe and coil assembly ready to install
fill tube connecting parts.

next items to install are the Teflon adapters and the connecting tube for the fill tube (figs. C4-20 through C4-22). With these parts in place, the quantity probe is bottomed in the counter-bore of the tank tube adapter (fig. C4-23). The fill tube parts are then checked to assure that they are in the proper position by use of a blunt probe through the side holes in the outer tube (fig. C4-24). The electrical feedthrough holes are aligned by eye with the electrical conduit and the entire unit is clamped into a jig for welding (figs. C4-25 through C4-27). Four 1/4-inch-long welds are positioned away from wires and the Teflon fill tube adapter to secure the assembly (figs. C4-28 and C4-29). The Unit is then inspected, cleaned, and bagged for future assembly into the tank.

Prior to final assembly of the tank, all major subassemblies are subjected to component acceptance tests. Specifically these major components are the following: pressure vessel, motor heater fan assembly, coil assembly, probe assembly, and the electrical connector. These tests check all functional aspects that are possible at that level of assembly, electrical isolation, pressure integrity, etc., as appropriate for particular components. These components are then moved to an area referred to as the Ultra Clean Room (a class 100,000 laminar flow clean room) for the final assembly. Operations in this area are performed in full lint-free nylon suits, boots, caps, and rubber gloves. Entry to this clean room is from the Apollo Assembly Area with a simple dressing room airlock for changing clothes. All equipment moves into and out of the area through airlocks.

The actual final assembly starts with opening the tank by removing the temporary shipping plug from the tank neck (fig. C4-30). Throughout the entire assembly operation, a vacuum cleaner nozzle is positioned adjacent to the tank to help reduce the possibility of dust or lint entering the tank. The heater assembly is then lowered part way into the tank (figs. C4-31 and C4-32). With the assembly held about halfway into the tank, the wires are fed in beside the heater until they are completely inside the tank. The heater is then lowered until the lower motor adapter pin is in the lower support bracket (fig. C4-33). The last portion of this lowering is accomplished by use of duckbill pliers (fig. C4-34). The top portion is then positioned for the upper bolt to be installed. The bolt is inserted by means of a wire holding loop and started by hand (figs. C4-35 and C4-36). This bolt is tightened with an open-end wrench with final torquing achieved by a combination of the open-end wrench and a standard torque wrench. The torque value is adjusted to account for the combined lever arm effect of the wrenches. At this point the wires are fished from the tank with hook (fig. C4-37). The wires are then checked and any tangles are removed. A small stainless safety wire is attached to the wires and they are lowered into the tank again (fig. C4-38).

Next a probe support fixture is attached to the tank neck and the probe is lowered about two thirds of the way into the tank (fig. C4-39).

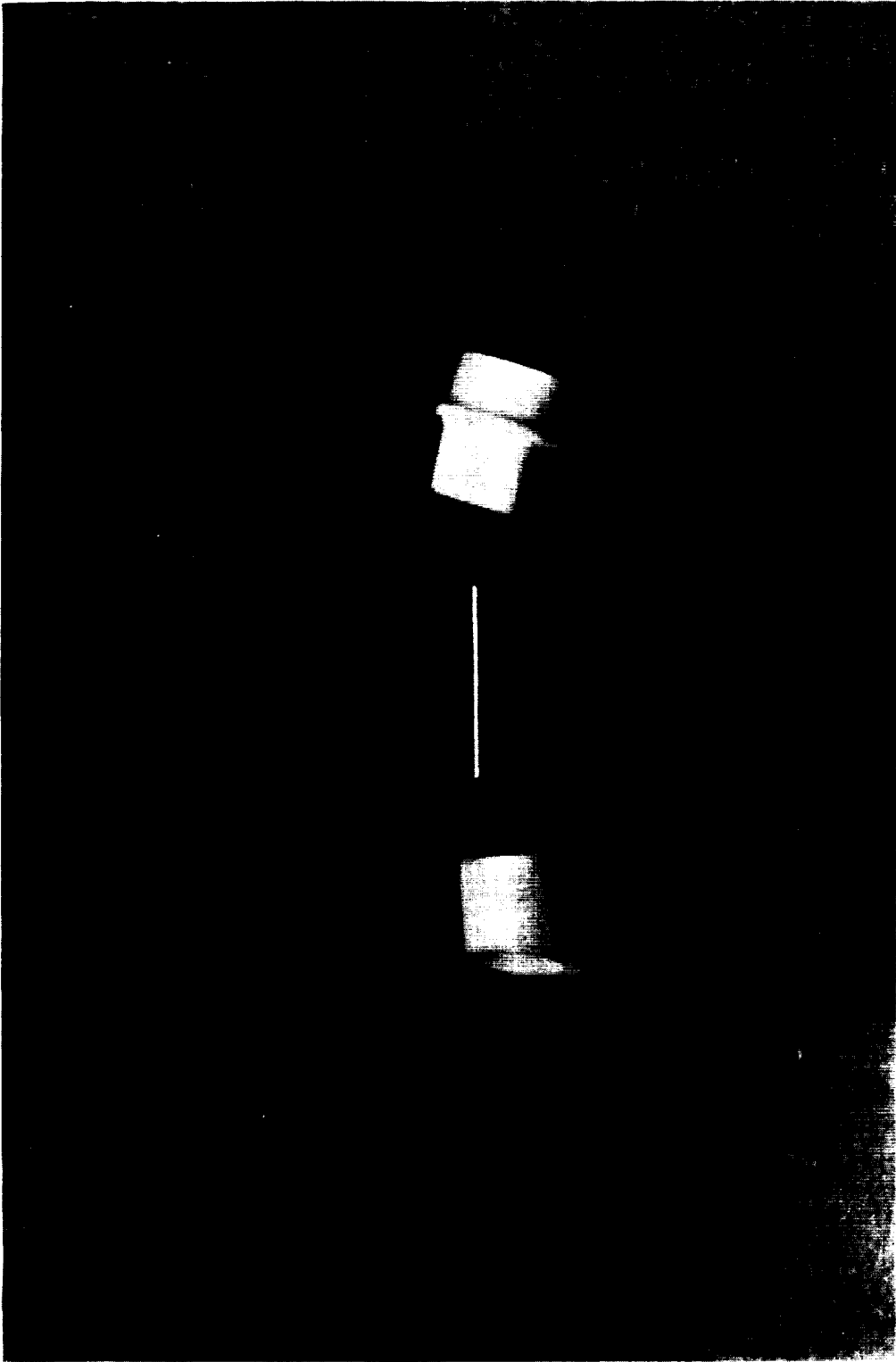

Figure C4-20.- Fill tube connecting parts.



Figure C4-21.- Installing fill tube connecting parts.

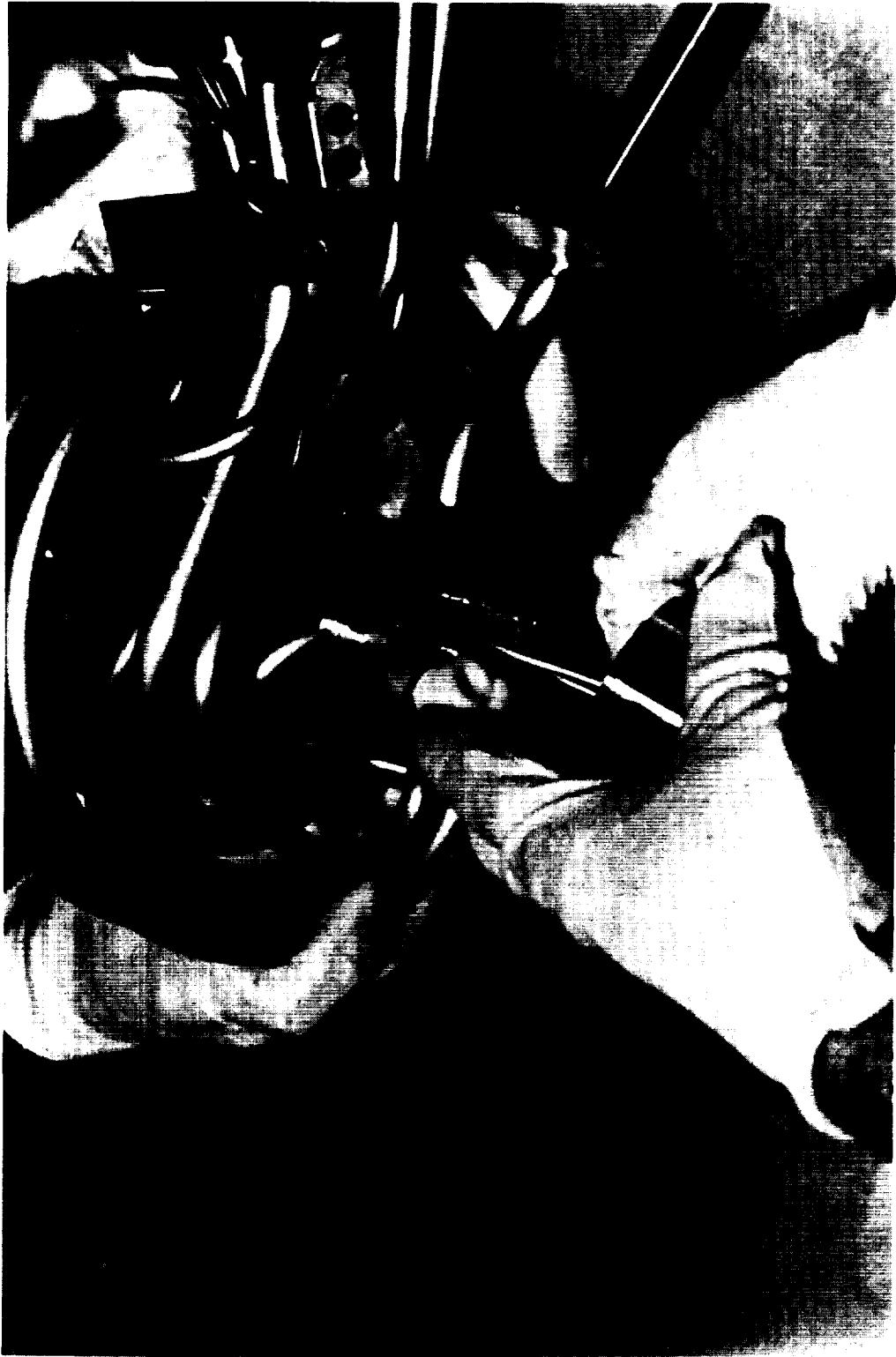

Figure C4-22.- Holding fill tube connecting parts in place.



Figure C-4.23 - Final mating of quantity probe and tank adapter.



Figure C4-24.- Probing to assure that fill tube parts are in proper position.



Figure C4-25.- Quantity probe and coil assembly in welding jig.

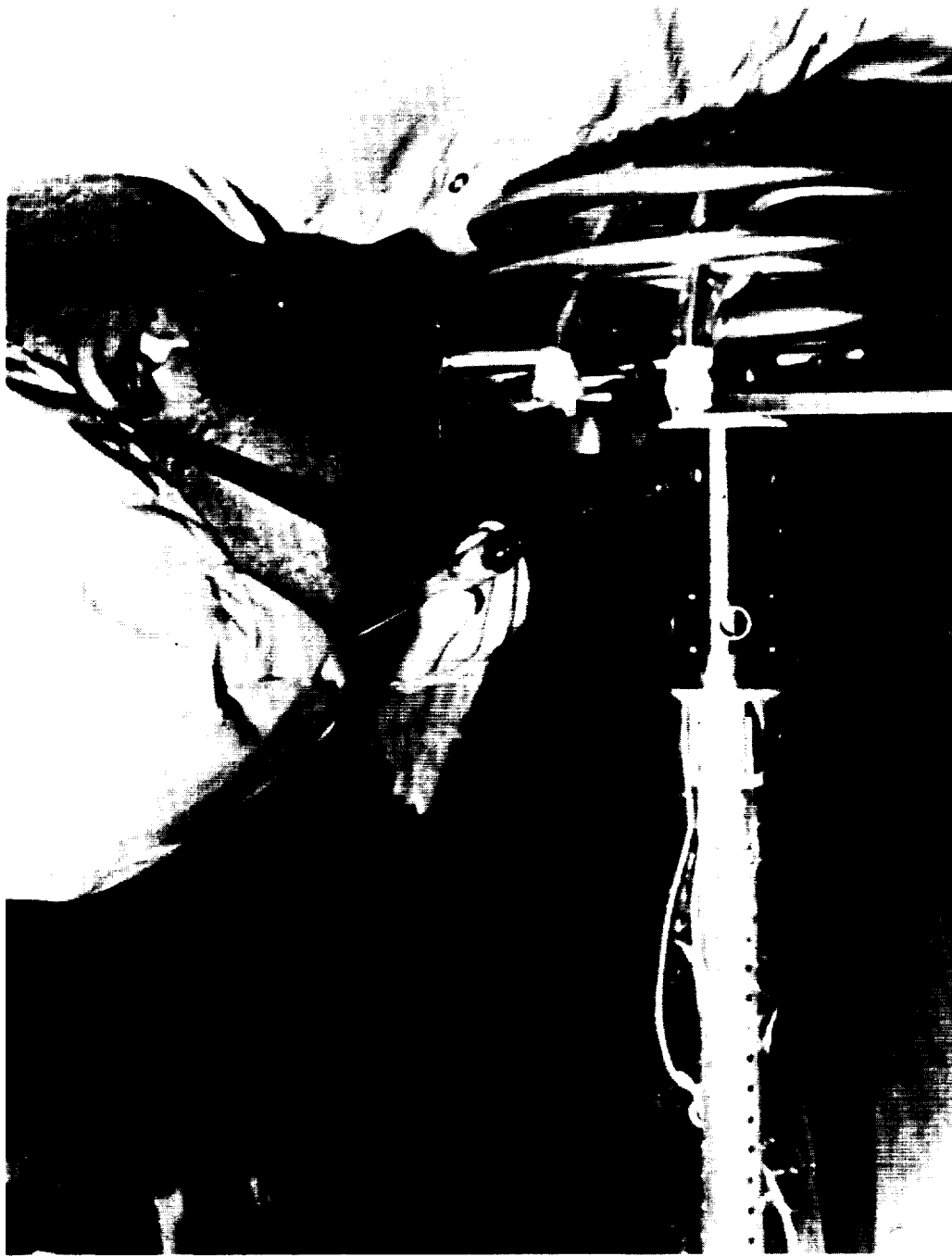

Figure C4-26.- Final inspection of fill tube connecting parts.



Figure C4-27.- Marking the weld positions.

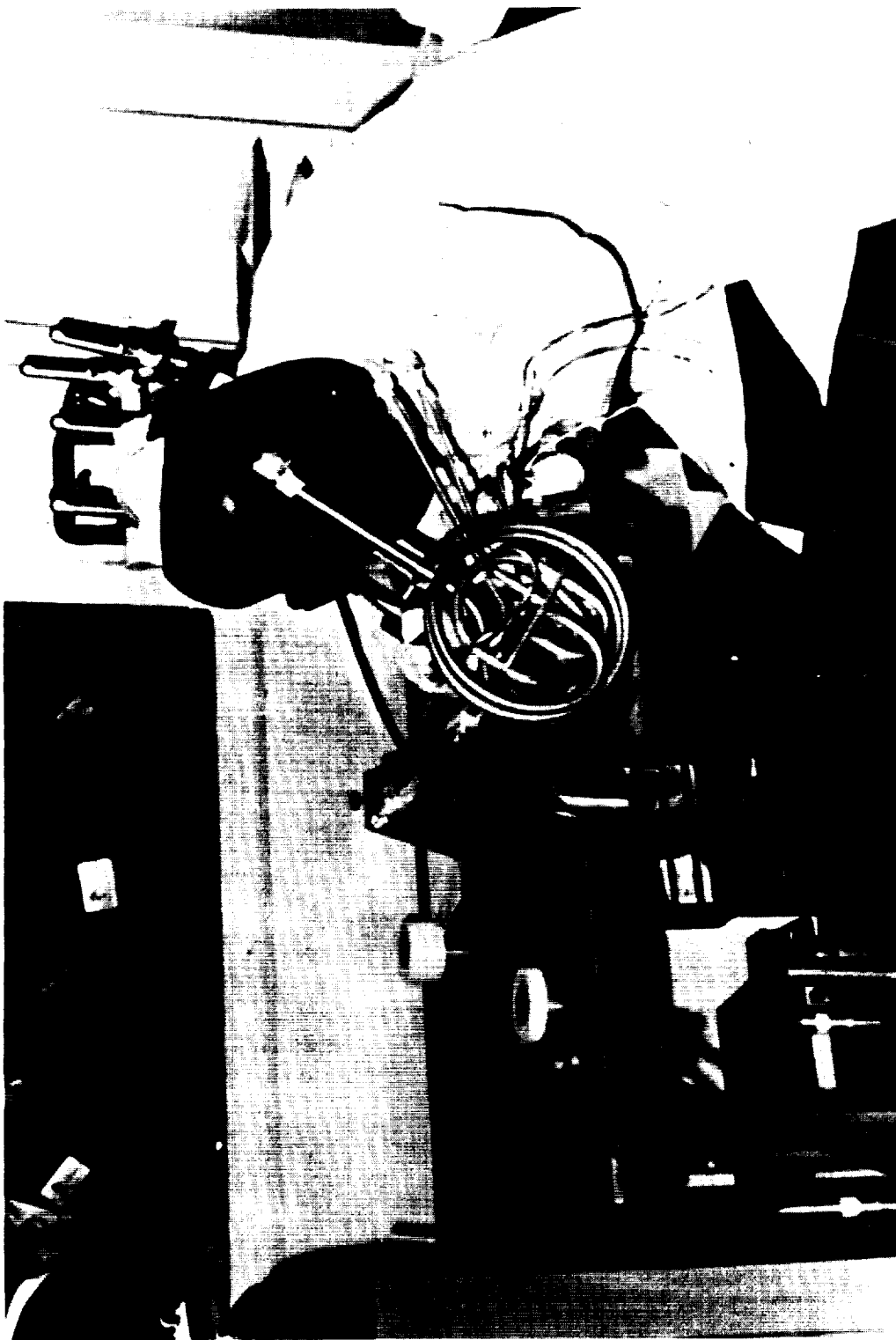

Figure C4-28.- Welding the quantity probe to coil assembly.

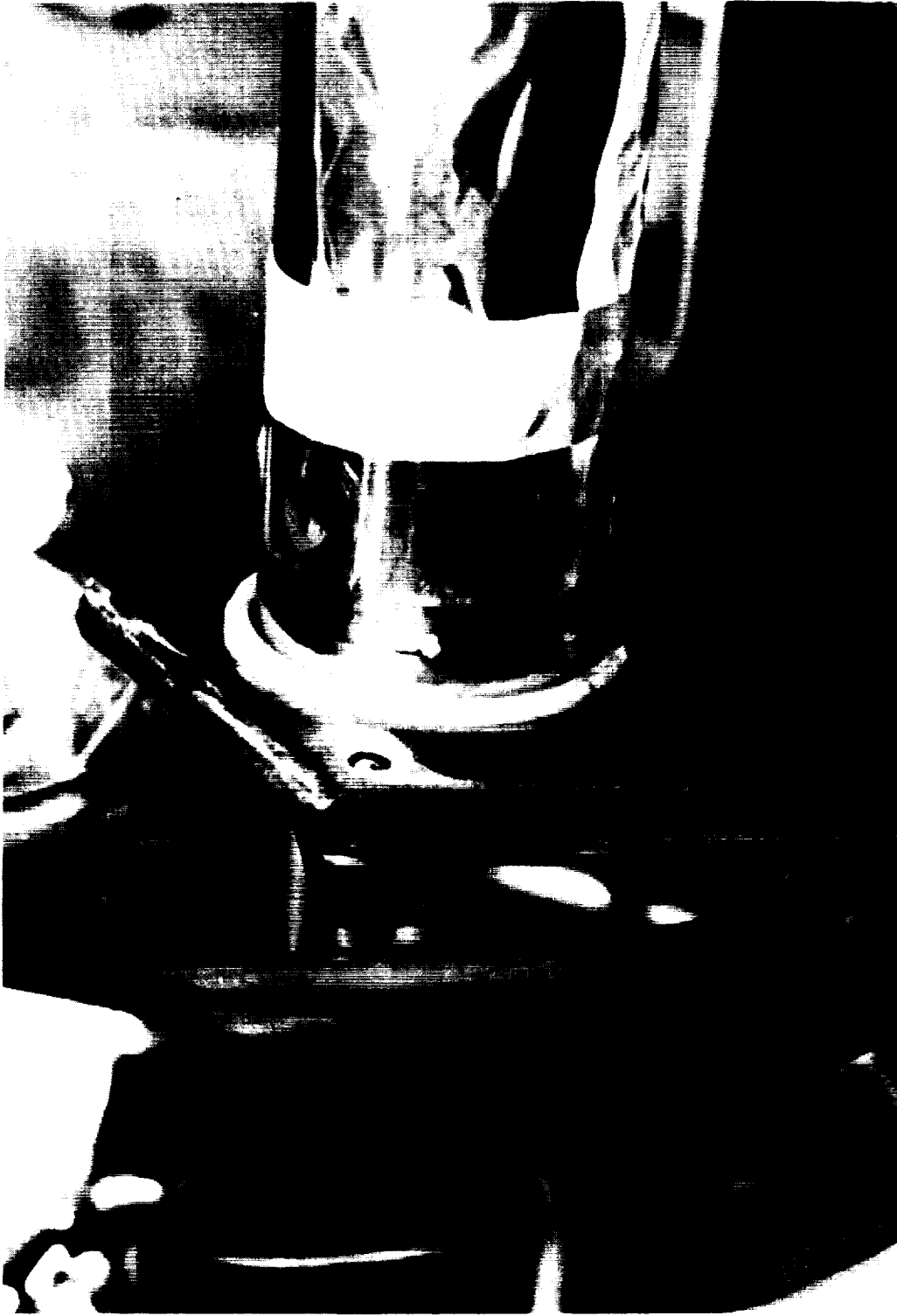

Figure C4-29.- The completed quantity probe to coil assembly welds.

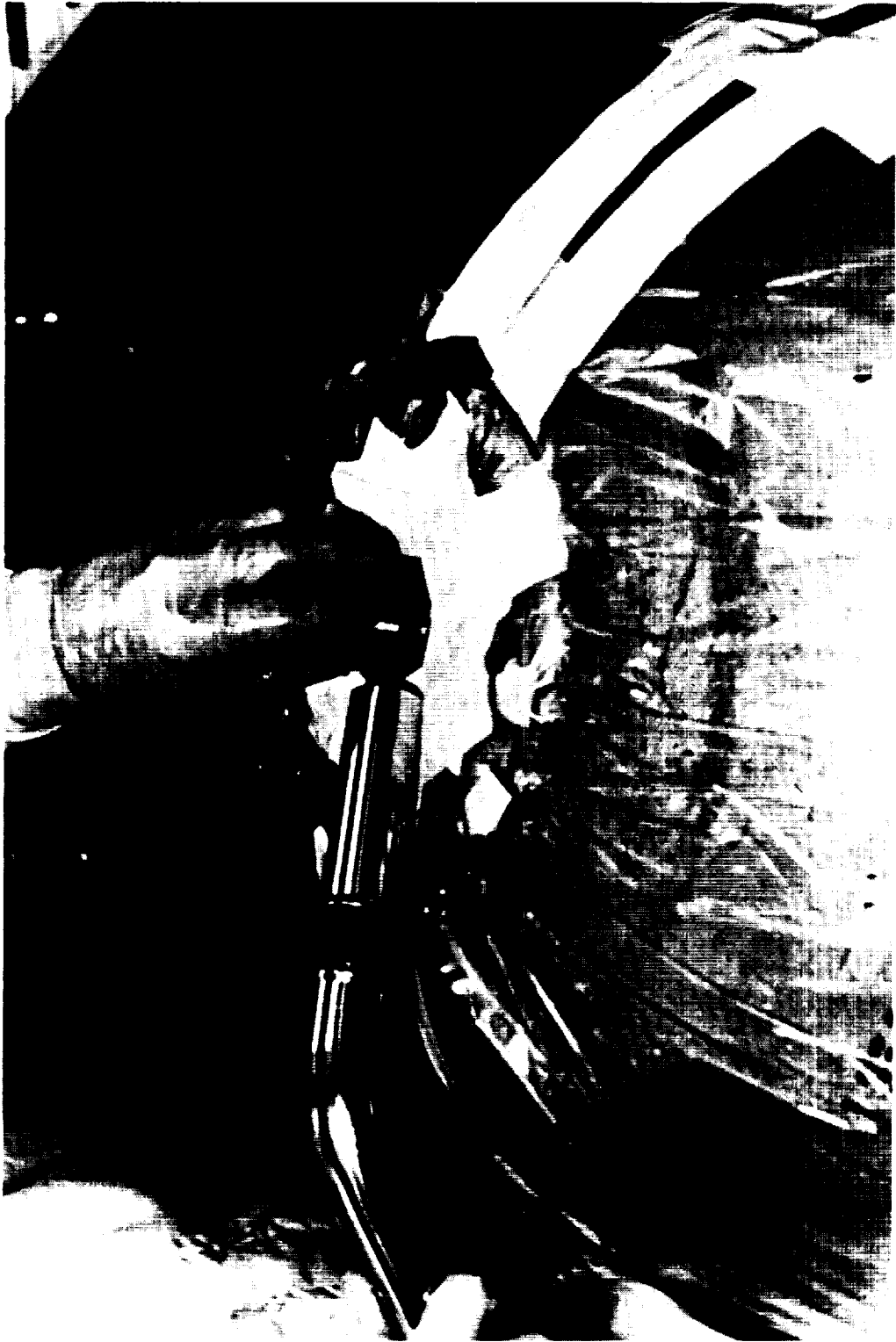

Figure C4-30.- Removing tank shipping plug.

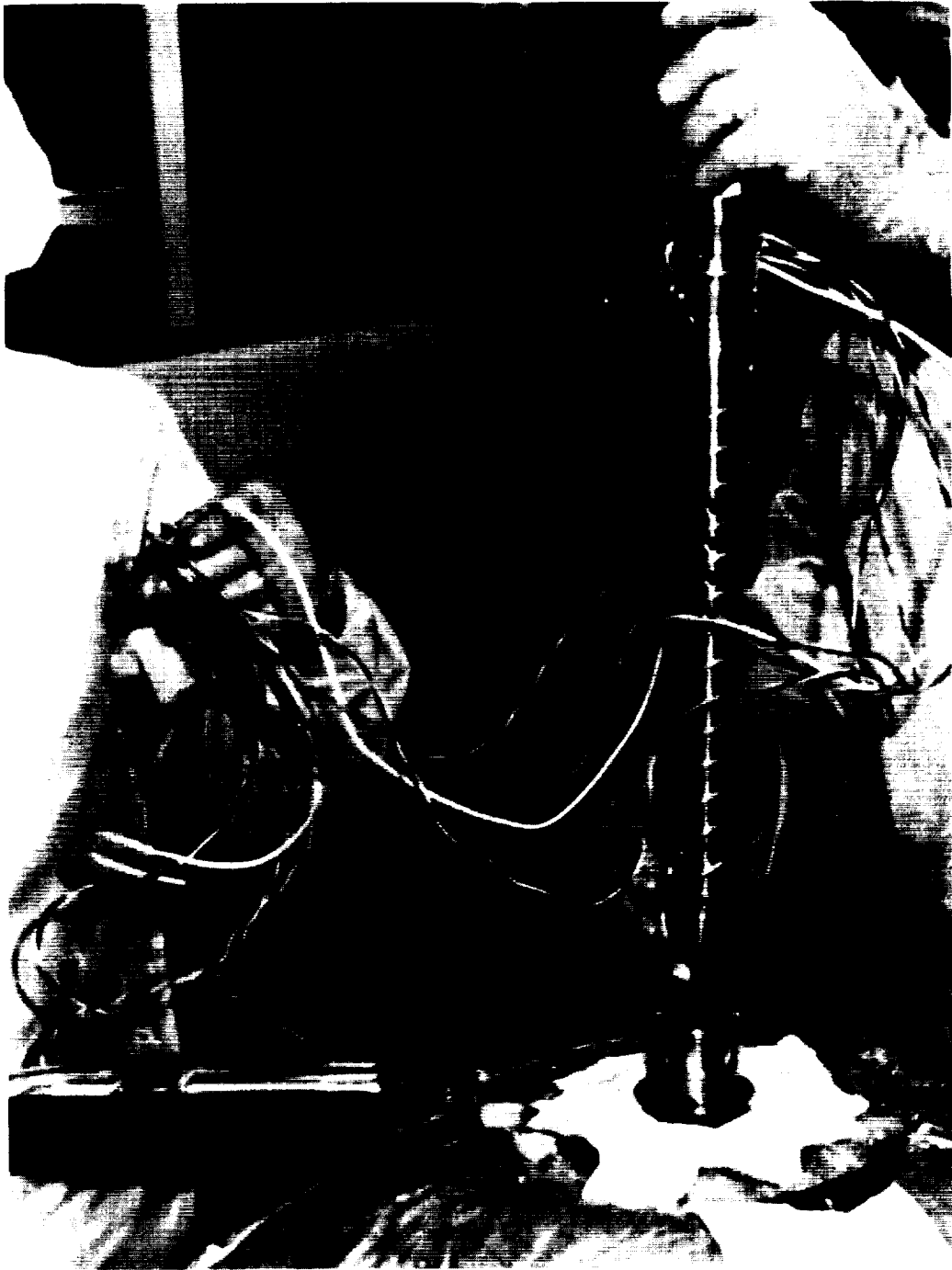

Figure C4-31.- Inserting fan and heater probe.



Figure C4-32.- Feeding wires into tank
beside heater probe.



Figure C4-33.- View inside tank showing heater probe in lower support.



Figure C4-34.- Final lowering of heater probe.



Figure 04-35.- Wire loop used to install heater probe retaining bolt.

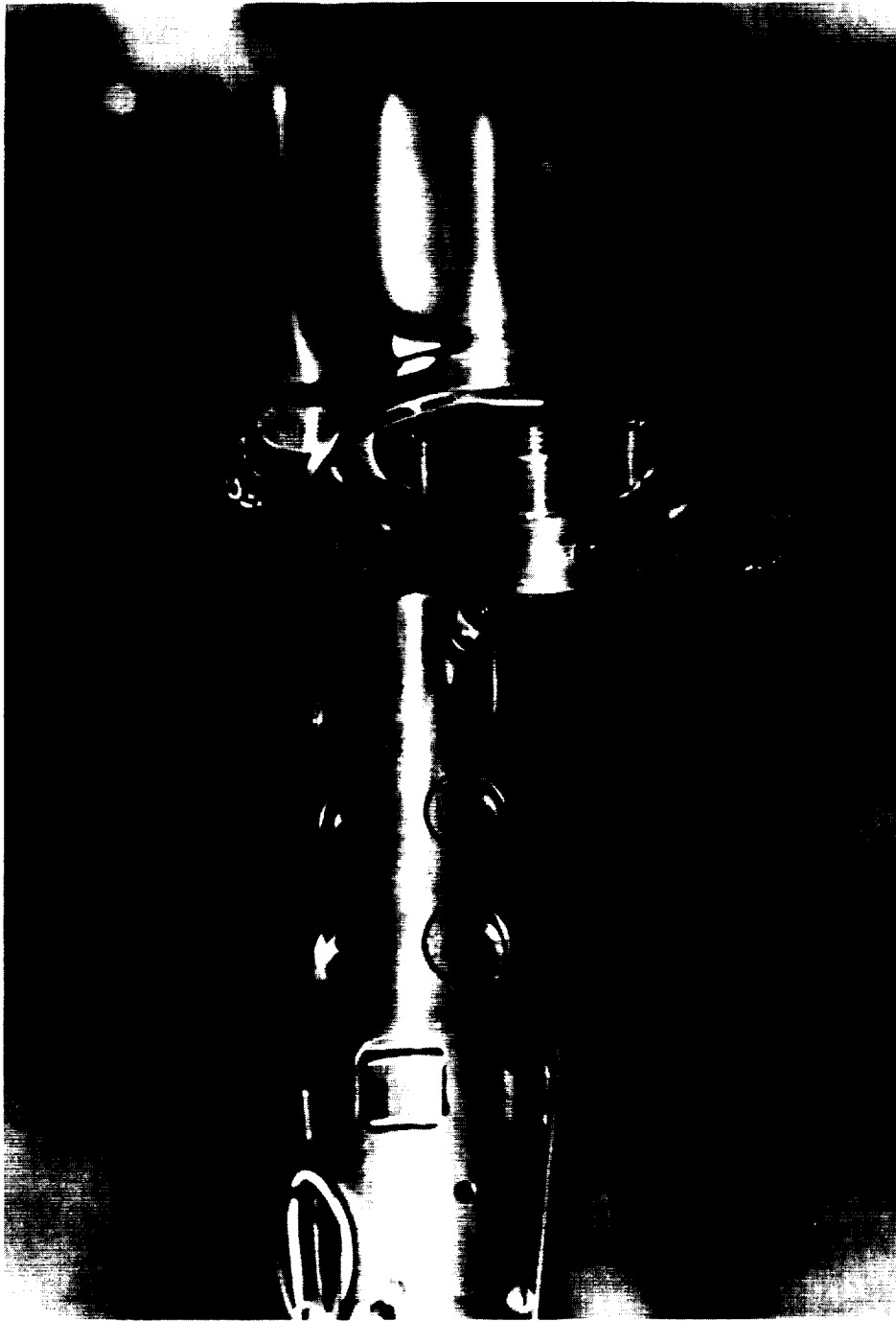

Figure C4-36.- View inside tank showing heater probe
upper retaining bolt.



Figure C4-37.- Pulling wires from tank.



Figure C4-38.- Lowering wires into tank with fixture
to hold quantity probe installed.

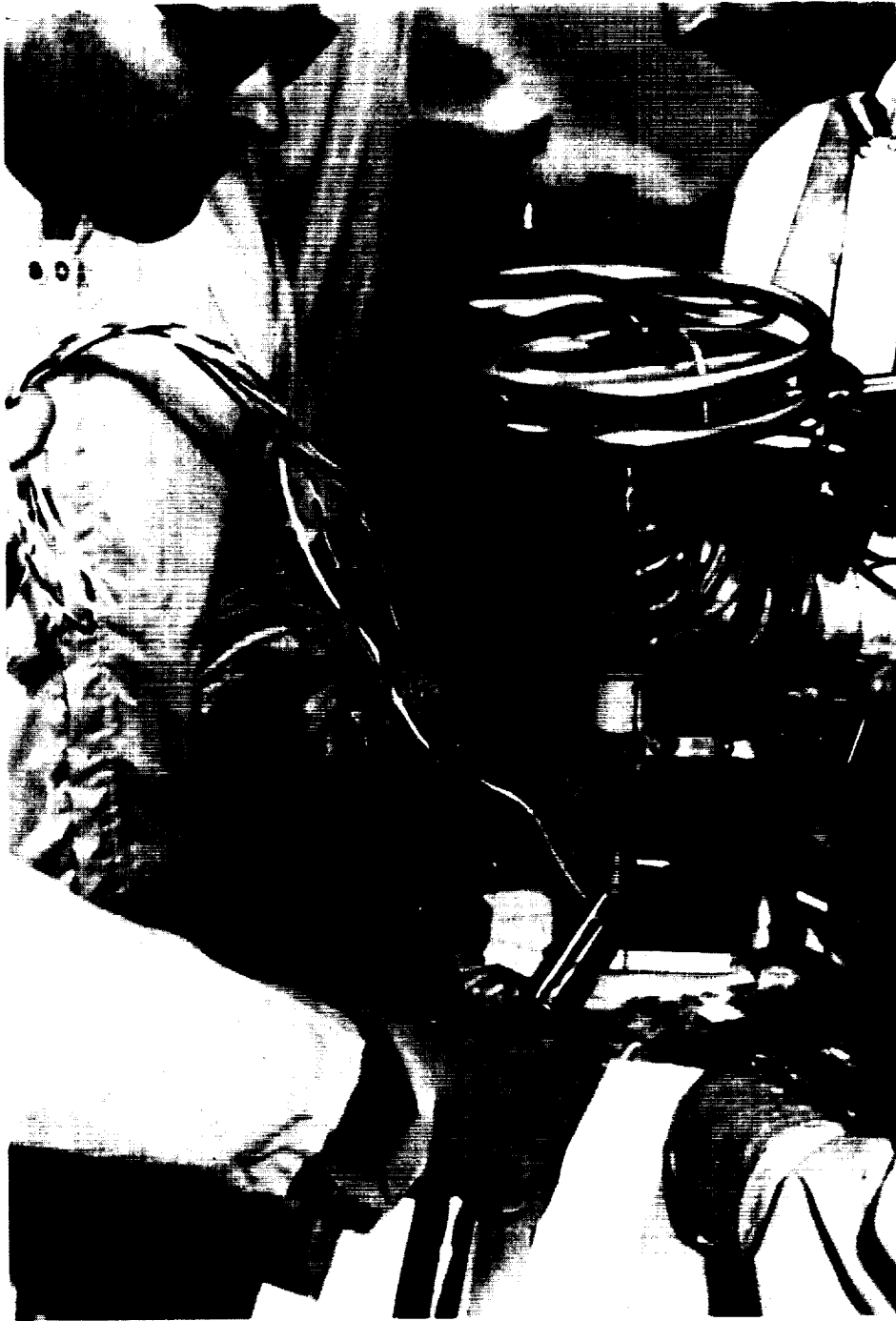

Figure C4-39.- Quantity probe being installed in fixture and heater probe wires being pulled from the tank.

At this point the wires are once again withdrawn from the tank. Again any possible tangles are removed. Then the pull wires previously installed in the probe are soldered to the motor and heater lead bundles. The solder joints are thoroughly cleaned and taped to make a smooth transition from each single pull wire to each bundle of six leads. These wire bundles are pulled into the conduit one bundle at a time with one man feeding the wires at the feedthrough hole in the quantity probe and the other man pulling approximately 25 to 35 pounds on the pull wire (figs. C4-40 through C4-42). The bundles are pulled through until the slack is taken out of the wire bundle with the probe in this elevated position (about 9 inches of slack when probe is lowered into tank) (fig. C4-43). Then holding the probe assembly, the fixture is removed from the tank neck and the probe is lowered into the tank (fig. C4-44). The probe assembly is then rotated counterclockwise approximately one turn. The unit is then very carefully rotated clockwise to start the quadruple thread and pilot the lower end of the probe into the ring provided at the bottom of the tank. If the probe assembly in the tight position does not result in alignment of the supply tube, then the probe assembly is re-indexed in 90-degree increments to achieve alignment. These procedures are carried out to a specific Manufacturing Operations Procedure and in the presence of quality control inspectors. (Figures C4-45 and C4-46 show the typical routing of wires from the heater and fan probe assembly into the quantity probe.)

The electrical connector is then installed so that a complete checkout can be performed on the electrical operations. The lead wires are cut about 3 inches beyond the connector adapter flange. At this point a 3-inch length of large-diameter Teflon sleeving is installed in the neck of the conduit. About 2 inches is slid into the conduit with about 1 inch protruding into connector space. The wires are thermally stripped, tinned, and soldered into the connector. After a thorough cleaning with alcohol, the connector is inspected with black light to assure complete removal of flux. After the resistance, isolation, and functional tests are completed, the metal sleeve is slid in place and welded. The connector proper is protected during the welding process by a set of copper chills which have cooled in liquid nitrogen. Even so, the weld is made in a series of short segments to limit the heat.

The next operation is the welding of feed line connections and the tank neck adapter. A helium leak test is run on the weld joints using a mass spectrometer leak detector. After satisfactory completion of these checks, the welds are all X-rayed.

Next, insulation is installed in the vacuum dome area. Two layers of aluminized Mylar are applied over the outer shell material that extends under the dome. The tank adapter flange is covered with four layers of aluminized Mylar. All the tubes in the dome area are wrapped with 1-inch aluminized Mylar strips held in place with nylon thread.



Figure C4-40.- Pulling first bundle of heater and fan motor leads into upper coil assembly.



Figure C4-41.- Pull wire used to route heater and fan motor leads into upper coil assembly.



Figure C4-42.- First bundle of heater and fan motor leads pulled through upper coil assembly.



Figure C4-43.- Heater and fan motor lead routing into quantity probe.



Figure C4-44.- Lowering quantity probe
assembly into tank.

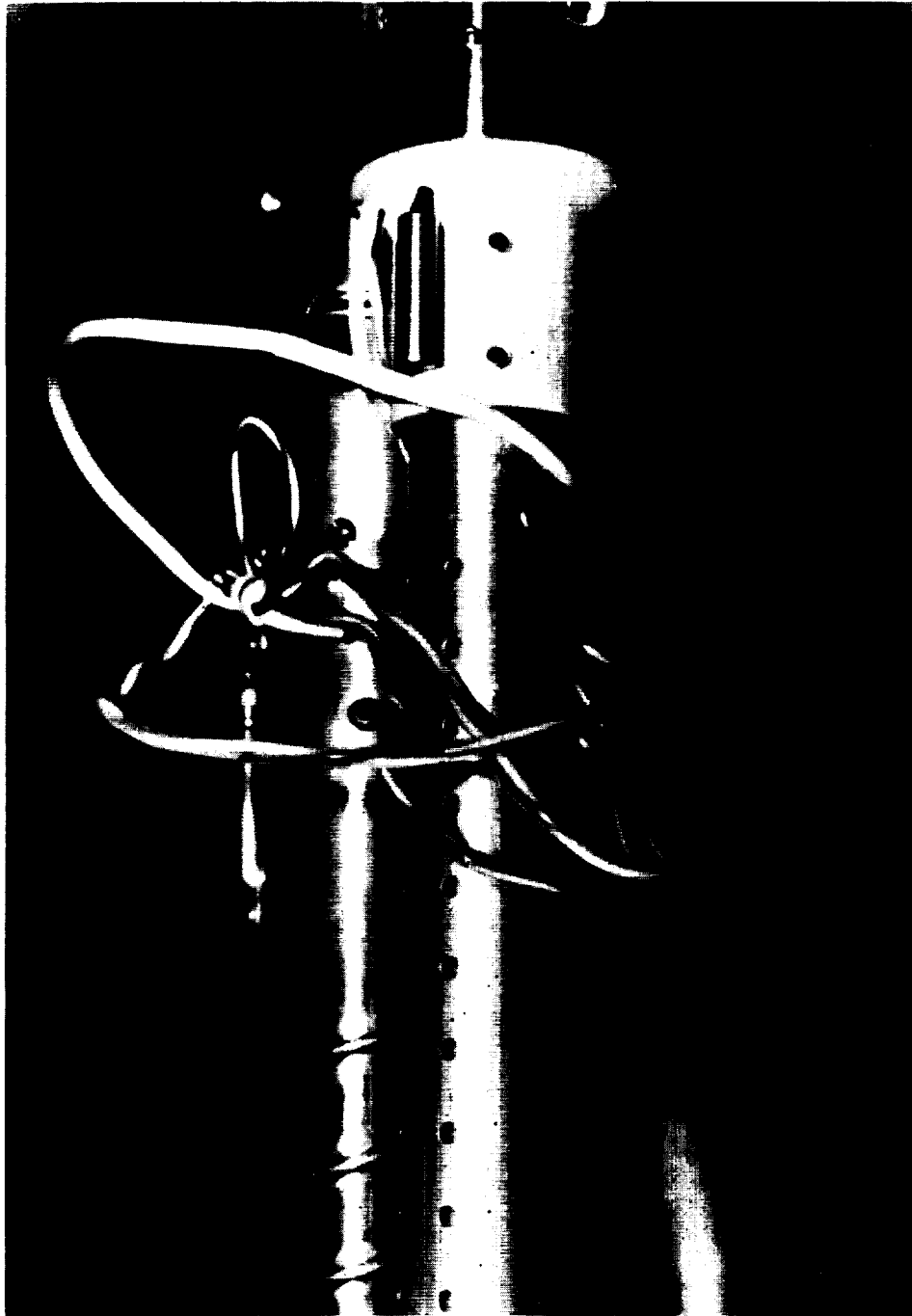

Figure C-4.45 - View inside of tank of typical wire routing from heater probe to quantity probe.

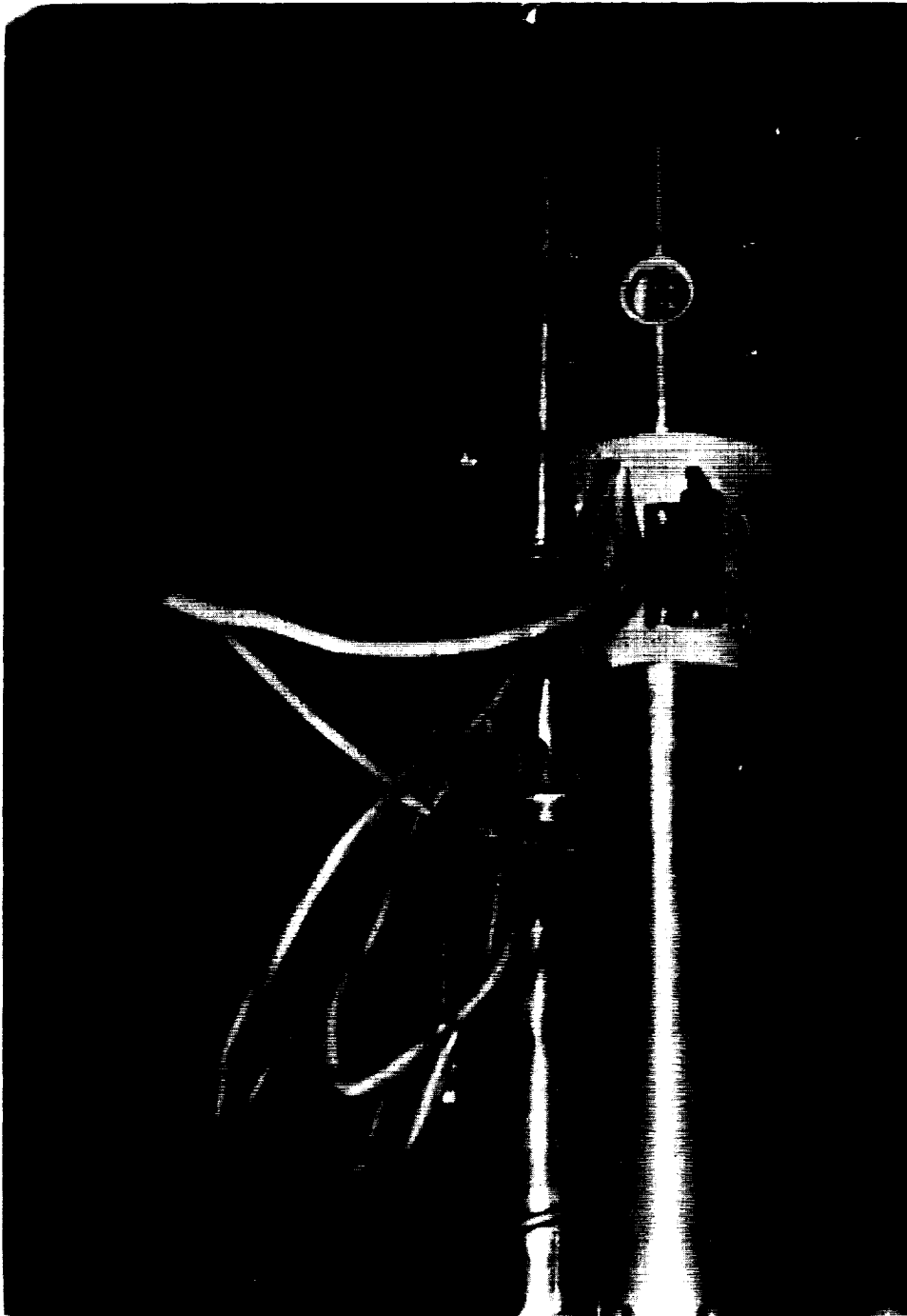

Figure C-4.46 - View inside of tank of typical wire routing of heater probe wires into quantity probe.

The coil housing (dome) cover is now welded in place. The housing contains the vacuum pumpdown tube, the blowout disc, and the vac-ion pump bracket (fig. C4-47). In addition, a pumpdown tube is welded to the lower hemisphere to speed the pumping process. After the welds are X-rayed, a preliminary pumpdown is made.

After a check is made to insure vacuum integrity, the vacuum is broken and additional insulation is stuffed into the dome area through the vacuum pumpdown tube. This insulation consists of 40 square feet of 0.0005-inch gold-coated Kapton which has been crinkled and cut into small pieces with pinking shears. (This represents about 5760 individual pieces approximately 1-inch square with pinked edges. This represents 2.3 ounces of Kapton.)

The actual pumpdown is accomplished in an oven at 190° to 220° F to speed the pumping and to assure a low final pressure. Because of the many layers of insulation, a complete pumpdown requires 20 to 28 days. At the completion of the pumpdown, the vacuum pumpdown tubes are pinched and sealed and protective caps are installed. The installation of the vac-ion pump completes the fabrication process of the tank assembly.

Acceptance Testing

End-item acceptance testing is a long and elaborate process controlled by a detailed written test procedure. The sequence consists of the following: (1) A dielectric strength test of the following wires or groups of wires shorted together. The test is run at 500 V dc and leakage current to ground (tank assembly) shall not exceed 0.25 milliamp; the four temperature sensor wires, the quantity gage outer tube lead, the quantity gage inner tube lead, the quantity gage inner tube lead shield, the eight wires from the two fan motors, the four wires from the two heaters, and the low-voltage input wires to the vac-ion pump; (2) Dielectric strength test of vac-ion converter output to ground (tank assembly) at 400 V dc. Leakage shall be no more than 0.8 milliamp; (3) Insulation resistance test to check that every wire or group of wires that should be isolated from other wires or ground shows a minimum of 2 megohms isolation at 500 V dc; (4) The isolation between the vac-ion pump electrical terminals and ground is tested at 500 V dc and must be at least 50 megohms; (5) The isolation between the vac-ion converter electrical output terminals and the tank assembly (ground) is tested at 500 V dc and must be 50 megohms or greater; (6) The vac-ion pump is functionally tested; (7) The inner vessel is pumped down for 4 hours to assure that the inner vessel is dry; (8) Helium leak test at 500 psi and a helium proof-pressure test at 1335 ± 20 psi; (9) A heater pressurization test and heat-leak test (vessel filled with liquid oxygen and 65 V ac supplied to heaters); (10) Cryogenic proof-pressure test at 1335 ± 20 psi (heaters powered by 65 V ac to raise pressure of liquid oxygen);

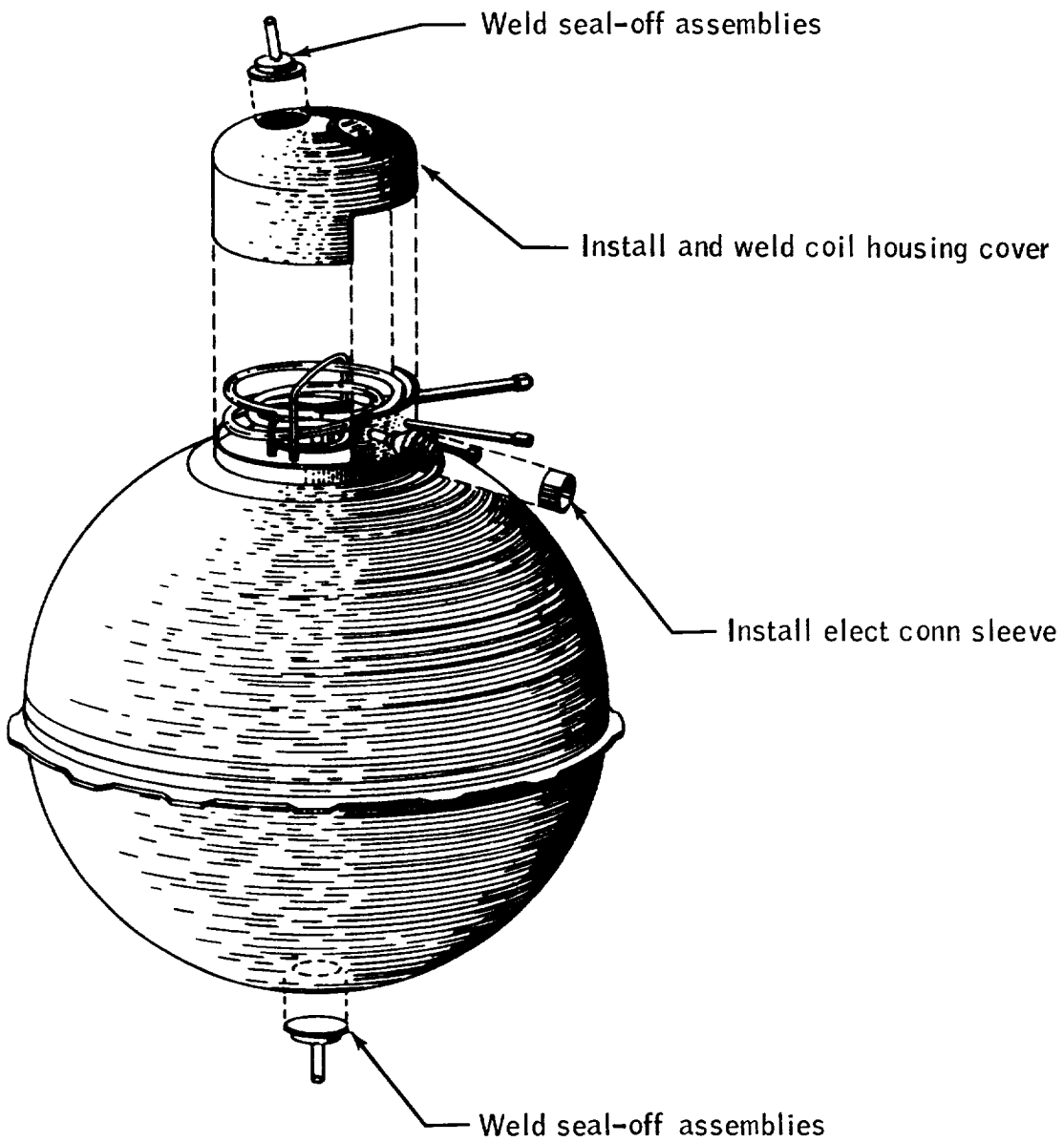

Figure C4-47.- Final vacuum closure operations.

(11) Heat-leak test; (12) Inerting of the vessel with 100° to 160° F nitrogen gas; (13) Check to see that thermostats are open when nitrogen purge temperature of 100° to 110° F flows from exit of tank (30 V ac applied momentarily to verify that thermostats are open); (14) Vac-ion pump final functional test; and (15) Final motor run verification and coastdown. The heat-leak tests consist of many runs to cover a range of ambient conditions and outflow rates. Total testing involves 40 to 60 hours with liquid or supercritical oxygen in the tank. Data sheets on cryogenic performance specified in the procedure are furnished to North American Rockwell in the end-item acceptance data package which accompanies each tank on delivery to North American Rockwell.

At the conclusion of the heat-leak test, approximately 100 pounds of oxygen remain in the tank which must be emptied and purged for delivery. Approximately three-fourths of the mass of oxygen in the tank is released from the tank through the supply line in the process of reducing tank pressure from the initial 925-935 psia to the final pressure of 25-35 psia. To complete emptying, the portion of this oxygen which remains liquid after the pressure bleeddown is expelled through the fill line. The application of warm gas at 30 psia through the vent line to accomplish this expulsion approximates the normal detanking procedure used by KSC at the completion of the CDDT. The CDDT is the next time, after delivery of the tank by Beech Aircraft to North American, that cryogenic oxygen is loaded into and expelled from each tank.

Summary of Significant Aspects of the Manufacture and Acceptance Test of Cryogenic Oxygen Storage Tank Serial No. 10024XTA0008

The manufacturing and test flow for cryogenic oxygen storage tank serial no. 10024XTA0008 is shown in figure C4-48. The item of particular significance is the recycle that was required in the manufacturing process brought on by motor failures.

The manufacturing history of the fan motors installed before or during 1966 contains many incidents of failures encountered in motor tests which resulted in design or fabrication process changes. The failure modes experienced were categorized as:

- (a) Contamination failures
- (b) Bridge ring (stator laminations) failures
- (c) Bearing failures
- (d) Phase-to-phase (stator windings) dielectric breakdown or shorts

- (e) Grounds (of stator wiring)
- (f) Lead wire damage (primarily at Beech)
- (g) (Motor fan) speed
- (h) Coastdown failures (less than 30 seconds in air or gas)

Design and manufacture process changes to minimize the effect of some of these failure modes were initiated during Block I motor manufacture. Most others were initiated before the motors used in tank 10024XTA0008 were assembled at Globe Industries. Failure mode (d) was the basis for the most recent changes affecting these particular motors. Corrective actions to employ extreme care in stator winding and to use phase-to-phase dielectric checks at 300 V rms were incorporated in the winding process. These were followed by a phase-to-phase dielectric check at 250 V rms after the winding was complete and before the terminals were soldered. Effectivity of these actions caught the lower motor in rework and the upper motor in original stator winding. After installation of the heater tube assembly, including the motor fans, Beech tested the motor wiring, shorted together, with 500 V dc to ground.

A listing of the inspection discrepancies issued against serial no. 10024XTA0008 are listed in table C4-I. In the Beech nomenclature these discrepancies are known as Withholding Forms. As stated previously, the motor problem is considered the significant item. The heat-leak problem was not considered serious because many missions required use rates above the minimum flow capability of tank 0008.

The oxygen storage tank assembly is normally handled and tested at Beech Aircraft in the upright position. Vertical motions may compact the tube set to minimum length so as to contribute to dislodgment by minimizing overlap with the upper stub tube nipple of the tank adapter.

Shortly before shipment from Beech, the tank is rotated (tumbled) while in a handling fixture, "to determine if all parts are secure." Since this is the only known source of side forces applied to the fill tube components and since the detanking was apparently normal in the Beech tests, it lends evidence to the assumption that the fill tube components were in the proper position at that time.

Investigation of Manufacturing Process and Supporting Analysis

To gain a first-hand appreciation of the manufacturing process, a visit was arranged to the Beech Aircraft Corporation, Boulder Division, to observe key assembly operations. In addition to a detailed discussion

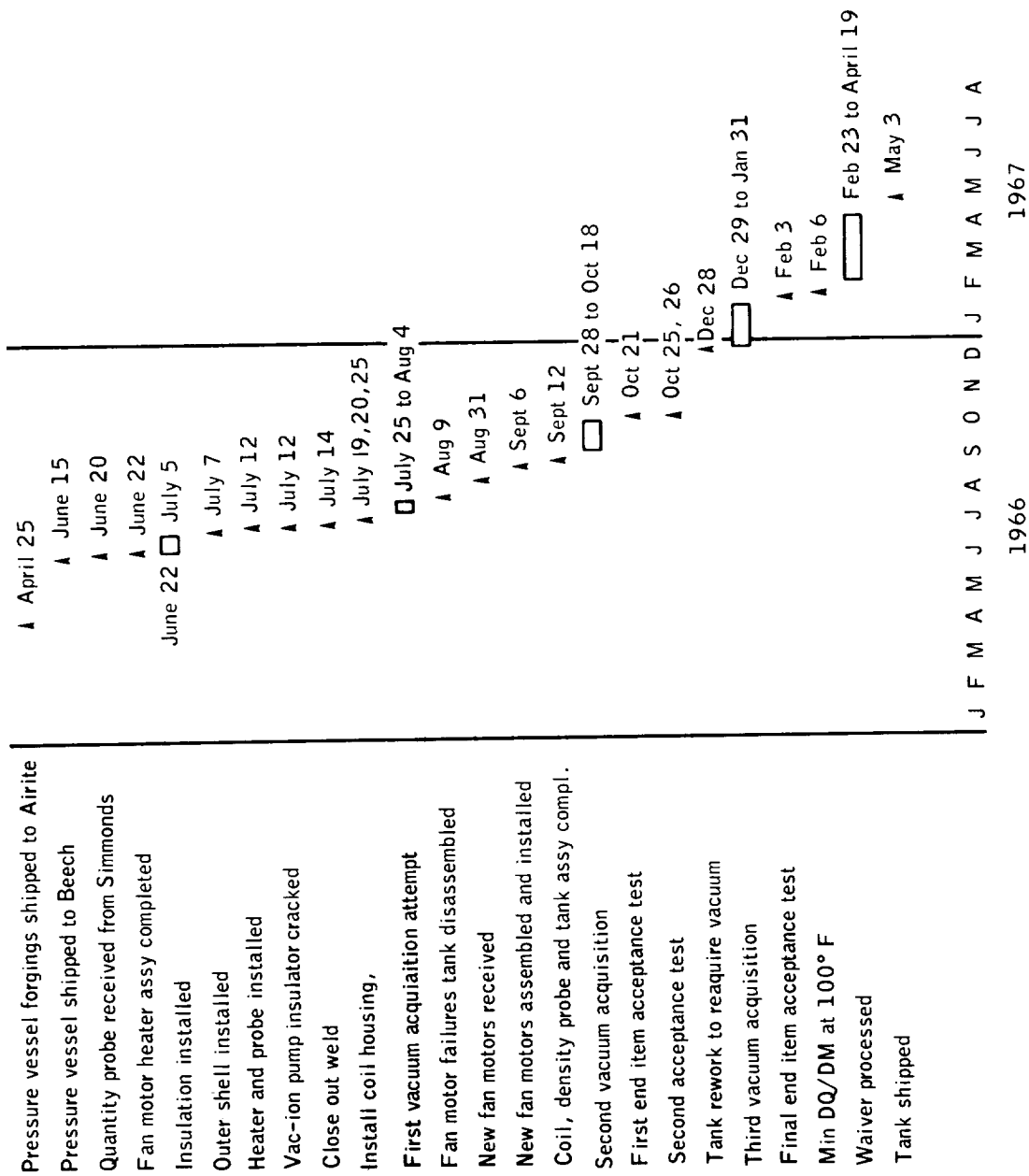

Figure C4-48.- Manufacturing and test flow for the oxygen tank at Beech.

TABLE C4-I.- WITHHOLDING FORMS (INSPECTION DISCREPANCIES)

Date	Part name	Part number	Tag number	Reason	Disposition
3-14-66	Heater tube assembly	13532-3527-3	B 00659	Oversize rivet hole 0.132 to 0.128 diameter, 0.006 inch oversize	Acceptable as is
3-28-66	Electrical support	13532-3187-3	C 78515	The 0.180 to 0.190 holes are 0.230 diameter	Acceptable as is
3-28-66	Lower shell assembly	13532-2011-13	C 55461-B	Two oversize pieces of porosity	Grind out and re weld X-ray and leak check
5-10-66	Hemisphere P.V.	13532-3109	C 10846	Out of tolerance condition in clamp ring area - Oversize	Machine to print
5-11-66	Motor fan assembly	13532-4505-3	B 50-1133	Motor draws excess current and emits a loud rough noise	Replace
6-1-66	Valve seat	13532-4029-3	B 01073	Valve seat damage when removed per PARR C-55461A	Scrap valve
6-30-66	Coil housing assembly	13532-2086-9	C 43101	Insulator has two cracks along side the weld bead	Replace
7-7-66	Porcelain insulator	13532-4075-1	B 00613A	Parts damaged beyond use	Replace
8-16-66	Motor fan assembly	13532-4505-3	B 01140	Motor failed after 4 hours of operation	Return to vendor Not acceptable
8-16-66	Motor fan assembly	13532-4505-3	B 01142	Insulation scraped from wire exposing bare conductor	Return to vendor for repair or replacement
8-23-66	Tank assembly	13532-1501-3	B 01184	Upper motor assembly noisy	Replace
9-2-66	Tank assembly	13532-1501-3	B 01238	MRR voided	Misinterpretation - shadow was thought to be contamination
10-18-66	Heater assembly	13532-2515-3	B 500147	Voided; No w/F required	
12-28-66	Tank assembly	13532-1501-3	B 500016	Flow rate not to specification Call out (CSM 0044)	Waiver approved April 19, 1967

of the step-by-step process, three assembly examples were witnessed within the clean room areas. Specifically, the installation of a lower motor into the heater tube was observed. The assembly of the quantity probe to the tank tube adapter fitting was witnessed. In this particular case, two attempts were required to properly position the small fill tube parts. The entire wire routing process was witnessed. A tank with a large hole in the side provided visibility to the witnesses but not to the assembly technicians. The installation of the heater fan assembly and then the quantity probe provided an appreciation of the real challenge to workmen, that of avoiding damage to the insulation of the wires. This could not have been learned from a study of the drawings alone.

A 10-times-size layout was made of the fill tube connection situation with the parts at the various limits of size permitted by the engineering drawings. In addition to the length tolerances permitted by the drawing dimensions, the diametral clearance also permits the parts to assume angles beyond the ranges stated on the drawings. As an aid to check all the various positions to which these parts could move, individual cutout paper parts were made for the two Teflon bushings and the interconnecting Inconel tube. Figure C4-49 shows that the worst-case short tolerance parts can fall out of position as the tank is moved about. At the other extreme, parts that are at the high end of the permitted tolerances will not assemble. This is shown on the left-hand view. The nominal case provided little or no axial clearance but still does not provide gas-tight seals at the various diameters.

In addition to the tolerance condition that can exist for the fill tube connecting parts, the center tube of the quantity probe could move downward due to Teflon cold flow. The center tube is supported in the axial position by two Teflon bushings installed in the center tube and a semi-tubular rivet. Prolonged heating, such as the vacuum pumpdown cycles (three cycles for this tank assembly resulting in a total of 1532 hours at 190 to 220° F), could result in the thin walls of the center tube slowly cutting into the Teflon bushings.

Table C4-II shows the range of diametral clearances that can exist at ambient conditions (73° F) and at a typical detanking condition (-278° F, which corresponds to the saturation temperature of liquid oxygen at 40 psia). The fit between the Teflon bushing and the tank adapter fitting can result in a maximum 0.003-inch interference. The only other clearance that results in an interference fit occurs if the minimum size holes are provided where the Teflon bushings slide on the 3/8-inch Inconel tube. Tests at liquid nitrogen temperature (-320° F) indicate that the Teflon is not overstressed and does not crack when subjected to interference fits of this type.

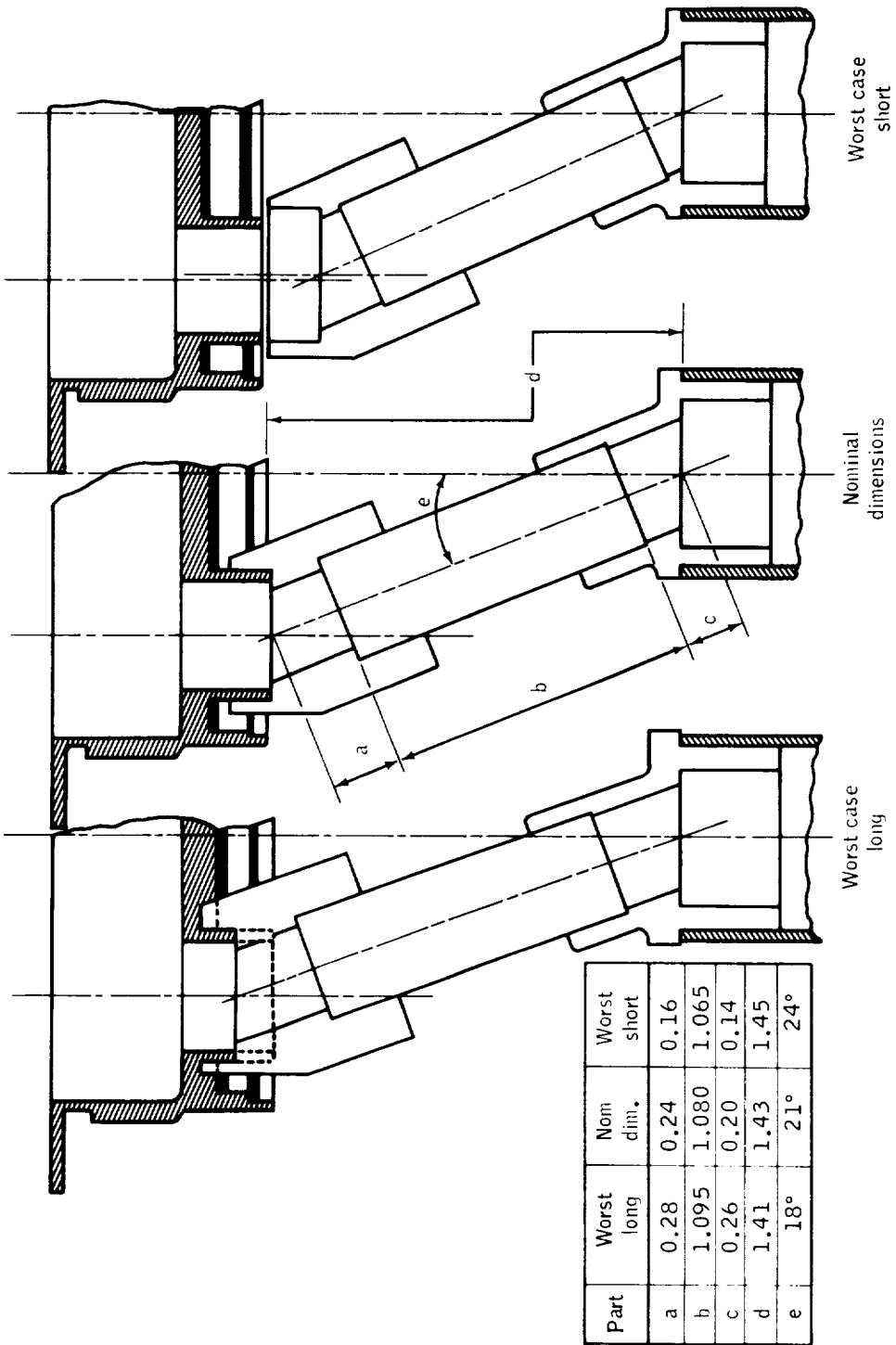

Figure C4-49.- Extreme and nominal tolerance cases for fill tube connection parts.

Throughout the normal manufacture and test of a cryogenic oxygen storage tank, no intentional procedure calls for the thermostats to interrupt a load. The acceptance testing by the thermostat vendor uses approximately 6.5 V ac to power a small lamp bulb which draws about 100 milliamperes. The fan and heater assembly component acceptance test by Beech uses the thermostats to complete the circuit of Wheatstone bridges to measure the heater resistance values. All other testing by Beech applies power (65 V ac) when tank conditions are such that the thermostats should be closed and remain closed, or momentarily applies a lower power (30 ± 10 V ac) to verify that thermostats are open.

INTEGRATION, SYSTEM TESTING, AND PRELAUNCH CHECKOUT OF THE CRYOGENIC OXYGEN STORAGE TANKS

Summary of Nominal Processes and Procedures

North American Rockwell, Downey, California.- The build-up of an oxygen shelf assembly at NR begins* many weeks before insertion of the cryogenic oxygen tanks with the fabrication of a pie-shaped aluminum honeycomb sandwich structural shelf with large circular cutouts matching the equatorial girth rings of the spherical tanks. On this shelf are next mounted the valves, pressure transducers, flowmeters, and tubing to interconnect these with the fill and vent panel and the storage tanks. Then the tanks are inserted, no. 1 inboard and no. 2 in the outboard position to the left of the fill panel and the valve module (fig. C4-50). To complete the shelf assembly, more tubes and the electrical cabling are added. The Beech signal conditioner assembly for each tank is mounted underneath the shelf.

All oxygen system tubing joints brazed by NR are subjected to X-ray inspection and reheated if necessary to achieve satisfactory joints.

Pressure and leak checks are conducted as are electrical checks of tank circuit elements, i.e., the vac-ion pump, the heater, motor fans, thermostats, and temperature sensor under dry gas conditions within the oxygen tanks. The thermostats are tested for both opening and closing temperatures by use of nitrogen gas purge with variable temperature control and monitoring each thermostat with a digital volt meter. Essentially no current is interrupted in these tests. Such tests are repeated in accordance with detailed Operational Checkout Procedures (OCP's) until all gas leaks or electrical wiring problems have been isolated and corrected and the oxygen shelf assembly is ready for installation in the

*Use of the present tense in this section of the Panel report implies current practices as of 1967-68.



Figure C4-50.- Oxygen shelf with tanks 10024XTA0008
and 10024XTA0009 installed.

service module. A proof gas pressure of 1262 psi is used, followed by leak testing at 745 psi. The vacuum pumps of the oxygen storage tank vacuum jackets are turned on at least twice during typical oxygen shelf checkout and oxygen system checkout at NR. These tests are conducted with an NR test engineer, manufacturing test conductor, technicians, and quality control personnel, and a NASA quality control representative present. No cryogenic oxygen is used in any of these tests.

After the oxygen shelf assembly is installed in the service module, various gas tubing and electrical connections are completed. The oxygen tank, tubing, and valves thereafter participate in oxygen subsystem testing of the service module, fuel cell simulator tests, and fuel cell interface verification in accordance with Detail Checkout of Systems (DCS's) requirements. Liquid nitrogen is used to introduce a cold nitrogen gas into the oxygen tank to cause the thermostats to close so that a heater circuit continuity test can be conducted. Spacecraft bus power (30 V dc) is applied to the heater circuits and an increase in current is used to verify thermostat closure. After water/glycol system test and final shelf inspection, cryogenic oxygen System Summary Acceptance is accomplished with NASA/MSR participation and recorded in the System Summary Acceptance Document ("SSAD book").

The discipline at NR, Downey, is that of controlled procedures and hardware traceability from the controlled material and equipment stores through assembly and test operations. This discipline produces requests for review or assistance from design engineering for instances of quality or test discrepancy considered to be significant.

Transportation from North American Rockwell to KSC.- Shipment of the service module from NR, Downey, is made on a pallet which holds the axis horizontal in the fore and aft direction of trucks and aircraft (fig. C4-51). The sector in which the oxygen shelf is installed is on the underside in this orientation so that the shelf centerline points vertically down. Shock and vibration instrumentation of various service module flights in the Pregnant Guppy and Super-Guppy special aircraft of Aero Spacelines have shown no peak vibration loads exceeding one-g for vibration-isolated movements of the service module.

Kennedy Space Center.- After command and service module mating, at the Manned Spacecraft Operations Building-KSC, the oxygen shelf assembly as a part of the service module participates in combined system test, altitude chamber test, systems integrated test, and flight readiness test in accordance with established Test and Checkout Procedures (TCP's). These tests are conducted as dry gas pressure and electrical function verifications similar to those of the factory OCP's and DCS's at Downey. No specific test is run to verify thermostat operation; however, during the conduct of a pressure switch test sequence, the thermostats may open the 28 V dc heater load.

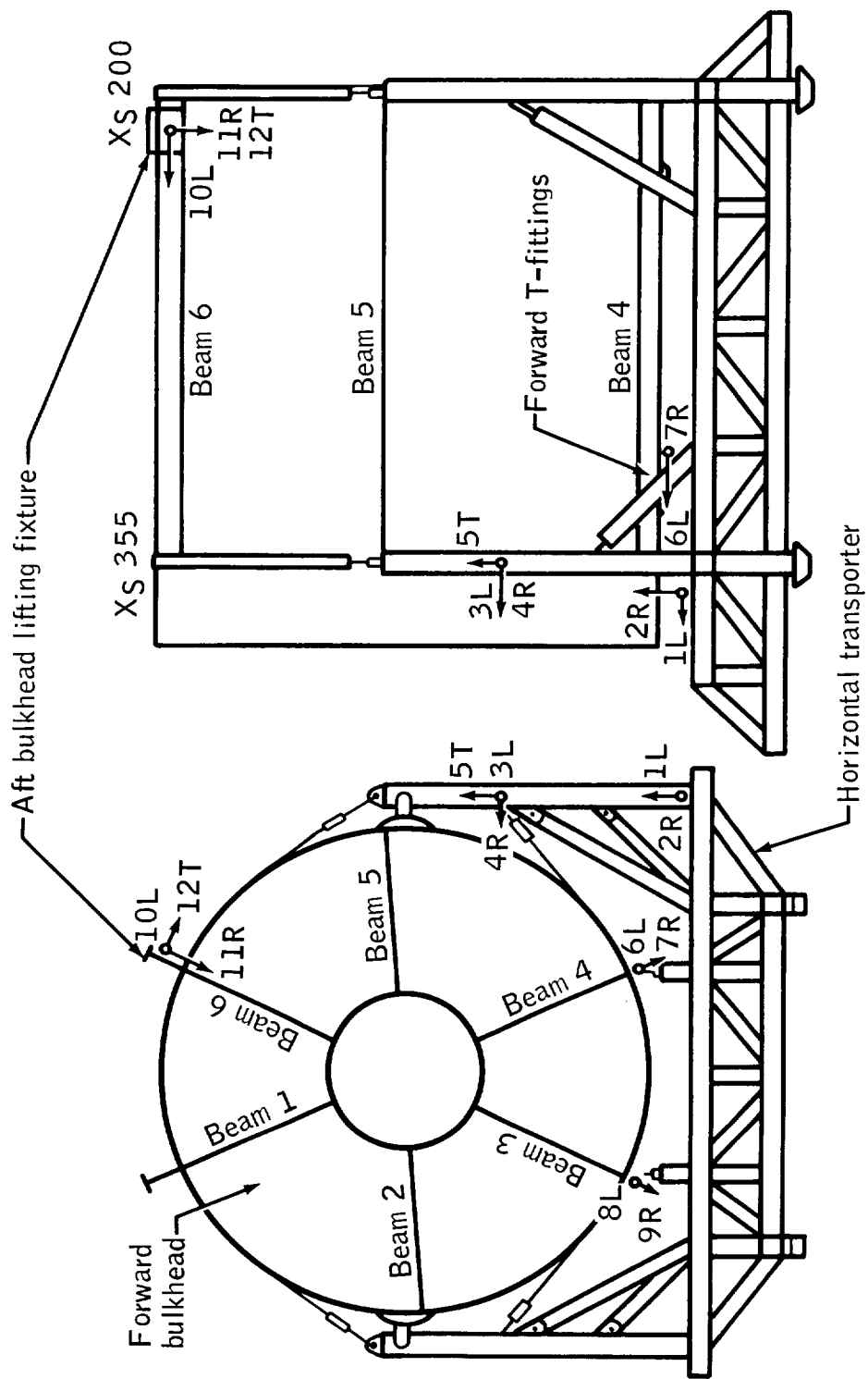

Figure C4-51.- Pallet holding axis horizontal in fore and aft direction of trucks and aircraft.

The vac-ion pumps of the oxygen storage tank vacuum jackets are normally turned on during three test periods at KSC including countdown. The circuit breakers to the vac-ion pumps are opened before launch.

After integration of the CSM with the Saturn launch vehicle in the Vertical Assembly Building, the complete vehicle is moved to Pad 39. As a part of the CDDT, which normally occurs 14 days before launch, the CSM storage tanks are fully loaded with liquid oxygen. The functioning of the fans is checked and heater operation verified by using a ground supply of 65 V dc to raise the tank pressure to about 300 psi. Shortly thereafter it is necessary to partly empty the oxygen tanks through a process known as "detanking." Two or three days later, at the conclusion of the CDDT, detanking is again used to empty the tank.

Initial detanking consists of two sequences. First, the internal pressure of the tank (residual to the CDDT) is vented through the vent. Next, warm gaseous oxygen is fed through the tank vent lines at 80 psia to expel liquid through the fill lines down to 50-percent full. Detanking for tank emptying proceeds similarly at the end of CDDT. Then warm gas is blown through to verify that the thermostats remain closed up to at least -75° F. This step employs the application of only 10 to 15 V dc to the heater circuit.

This loading, checkout, and detanking is the first time the cryogenic functions of the oxygen storage tanks are evaluated since the acceptance test at Beech Aircraft, Boulder, Colorado.

The oxygen tanks are filled to capacity during actual countdown in order to prepare for launch.

During the CDDT and during the final countdown, as long as the Mobile Service Structure (MSS) is connected to the Launch Umbilical Tower (LUT), the heaters are powered from the ground supply system. The power distribution station from where the heaters are powered is located at the base of the LUT. The voltage from this power supply is automatically regulated at 78 ± 2 V dc and recorded. There is approximately 13 volts line drop along the connecting leads, resulting in about 65 V dc across the heaters, producing a current of about 6 amps through each heater element. This higher power operation is used to more rapidly raise the tank pressure to the operating range.

The MSS is disconnected from the LUT at about 18 hours before T - 0 in both the CDDT and the final countdown. For operational reasons the power supply to the heaters is switched at this time to the busses of the spacecraft with 28 to 30 V dc (about 2.8 amperes through each heater element) which are powered through the umbilical from the ground supply system. At T - 4 hours, during the launch preparation, the busses of the spacecraft are switched to the fuel cells. The destratification fans are independent from the heaters and at all times powered from the spacecraft.

Summary of Significant Aspects of Serial No. 0008 Tank
Prelaunch Integration Test and Checkout History

North American Rockwell, Downey, California.- Oxygen storage tank 10024XTA0008 was installed in the no. 2 (outside) position of oxygen shelf S/N 06362AAG3277 at North American Rockwell, Downey, California, soon after receipt in May 1967. Two disposition reports were written during October 1967 to require reheat and reinspection of brazed tubing joints on the oxygen shelf found unacceptable in reading of X-rays. These joints were reheated and accepted. Completion of oxygen tank installation, including tank 10024XTA0009 in the no. 1 position, was accomplished March 11, 1968. Manufacturing and test flow for the oxygen shelf is displayed chronologically in figure C4-52.

Two disposition reports noting an "indentation" and a "ding" in the tank outer shell were filed and accepted--use as is--in March and April 1968.

During April and May 1968, 11 disposition reports were written to log tank no. 2 anomalies found during proof-pressure, leak-check, and functional checkout of the assembled oxygen shelf. Eight of these were ascribed to test procedure problems, two to a valve module (check valve) tubing leak and one to an electrical connector pin. The leak was rewelded by a Parker technician and passed leak test. The pin was repaired by NR and checked.

In accordance with the normal OCP and after leak and electrical repairs, the shelf assembly was completed and tested. It was installed in CSM 106 June 4, 1968. Thereafter, in compliance with several DCS's for subsystem test, a fuel cell simulator test, and fuel cell interface verification, the oxygen shelf participated in service module detailed checkout steps.

After installation of this oxygen shelf in SM 106, eight disposition reports were written during installation, additional tubing connection and subsystem line proof-pressure and leak check, and electrical cabling checking. Of these, two problems with a hydrogen relief line mounted adjacent to the oxygen shelf were solved by making up new tubing and later reheating a brazed joint to meet X-ray control requirements. Three oxygen subsystem leaks were solved by retorquing caps and a "B" nut on oxygen lines leading to fuel cell no. 2. The three remaining disposition records expressed questions concerning leak and electrical function testing of the oxygen shelf assembly which were held open pending the next opportunity for shelf assembly testing.

On October 21, 1968, in response to directives requiring rework of the vac-ion pump dc-to-dc converters to reduce electromagnetic

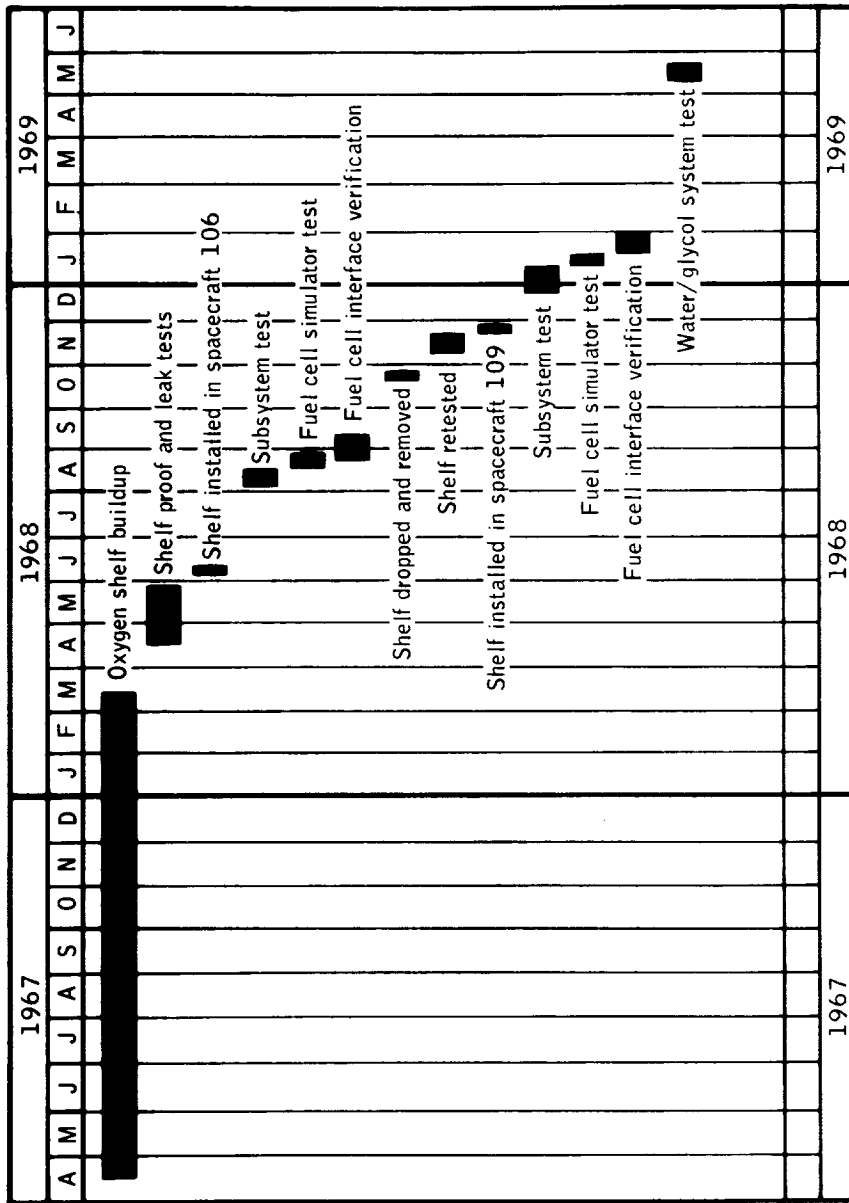

Figure C4-52.- Manufacturing and test flow for the oxygen shelf.

interference problems (a supplementary potting operation performed by Beech personnel at North American Rockwell), an attempt was made to remove the oxygen shelf from SM 106.

In preparation for this attempt, the 10 bolts attaching the shelf to the adjacent beams were removed. The existence of a small, 11th bolt introduced from underneath and behind tank no. 1 was overlooked by all persons involved. The factory crew brought into position a lifting fixture particularly devised for inserting tanks and shelves into sectors of the service module (fig. C4-53).

This fixture is composed of two parts joined at a bolted flange. The universal part is an adjustable counterbalance. The weights of this counterbalance are movable from the factory floor through endless chains. The particular part for handling to the oxygen shelf is a two-tined fork welded together from large thick-walled aluminum tubes. The tine tips are padded where they contact the underside of the shelf to support its inner portion. The outer edge of the shelf is fastened to the lifting fork by means of two screws passing through tabs on the top of the fork cross-member.

Under the particular circumstances of October 21, 1968, the unnoticed 11th bolt into the shelf served as a tie-down beyond the tips of the lifting fork such that raising the fixture produced rotation of the entire assembly, most noticeably the counterbalance. The 11th bolt still was unobserved. Attempts were made to balance the fixture by moving a weight and to lift the assembly by operating the overhead bridge crane. In these steps sufficient load was placed on the fixture to break it above the cross-arm of the fork.

The oxygen shelf moved and came to rest on the supporting beams through what was at the time described as a "2-inch drop". Observation of adjacent portions of SM 106 identified minor damage, including a dent in the underside of the fuel cell shelf above.

Figure C4-54 shows the repair patch over this dent immediately above the vacuum pinch-off cover can of tank no. 2 in the oxygen shelf that replaced the one undergoing the "shelf drop" incident in SM 106.

Further attention to the oxygen shelf containing tank 10024XTA0008 in the no. 2 position after its removal from SM 106 involved a number of quality, test, and repair actions. These were logged on 11 separate Disposition Records (NR numbered forms recording discrepancies observed through manufacturing inspection and test activities at Downey). One other such form was initiated at the time of the "shelf drop" and was treated primarily as a requirement to inspect, repair, and re-inspect the adjacent portions of SM 106, including specifically the dented fuel cell shelf.

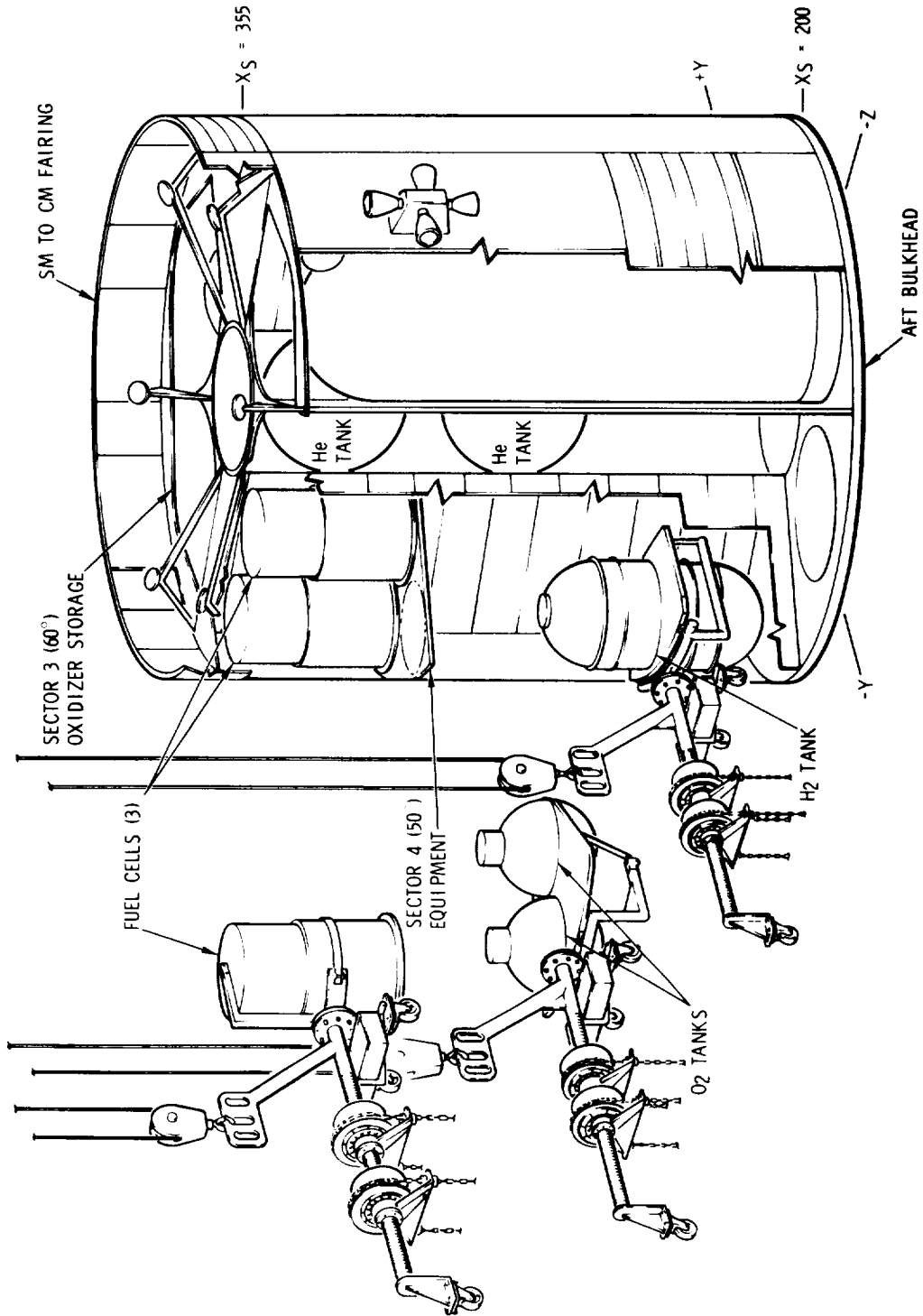

Figure C4-53.- SM bay 4 tank installation.

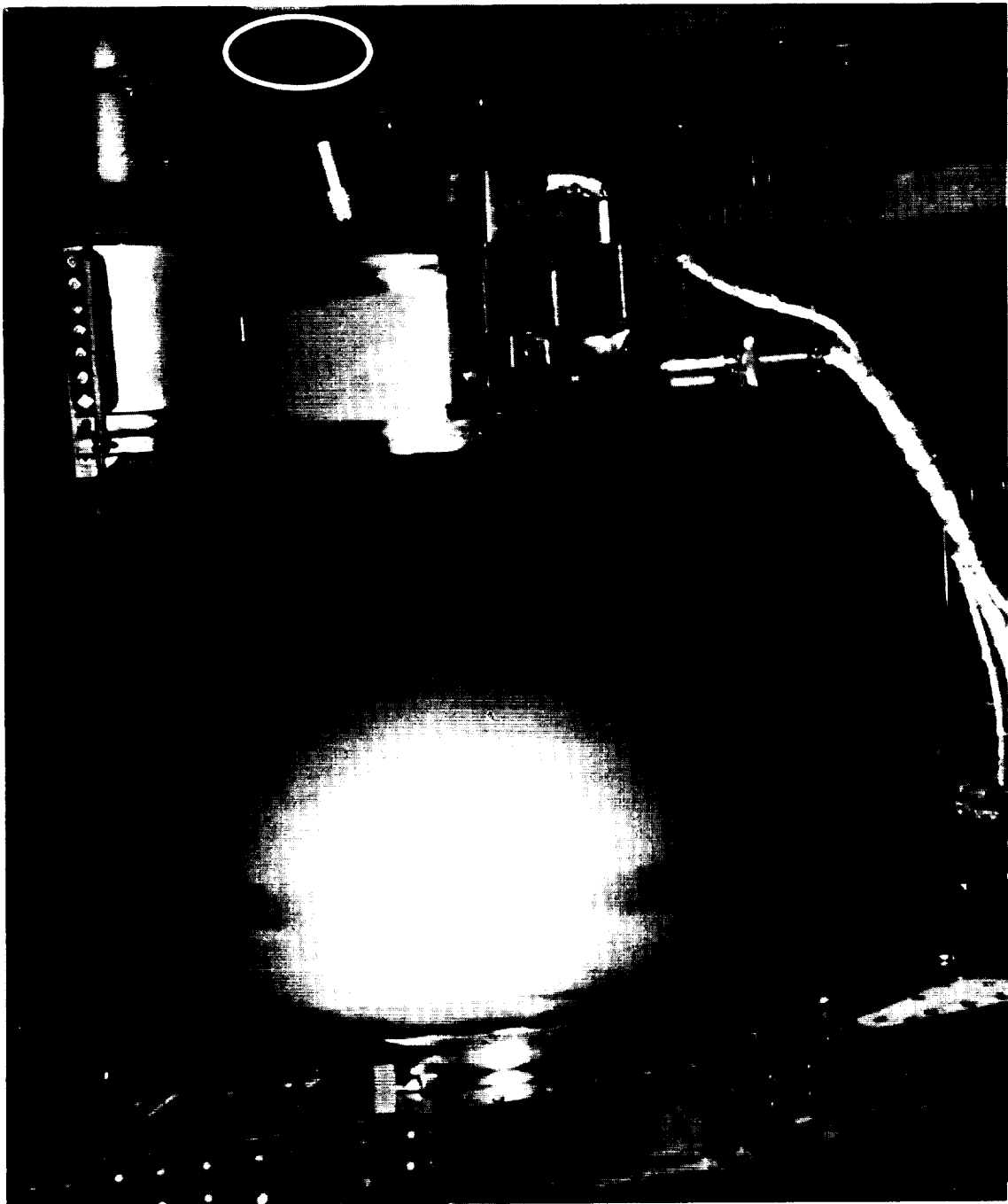

Figure C4-54.- Replacement oxygen shelf installed in Service Module 106. Note repairs to fuel cell shelf over oxygen tank no. 2.

Of the 11 DR's, five report anomalous conditions of detailed portions of the shelf assembly observed and recorded from November 1 to November 19, 1968. In response to these DR's, EMI tests and leakage tests were conducted, results were accepted, and some repairs were made. The leak tests of bent tubing carrying tank no. 1 pressure, upstream from valves, were accepted in material review. The latter involved polishing out tank outer shell scratches, adjusting several electrical connectors, replacing damaged cable clamps, and coating damaged potting. It is not certain but it is possible that some of these conditions relate to the "shelf drop" incident.

The remainder of the DR's of the period relate to testing the oxygen shelf to revalidate it for installation into SM 109. A shortened version of the normal pre-installation OCP, including pressure and external leak testing and verification of electrical functions of most of the tank elements, was conducted. Fan motor, heater, fuel cell reactant valve, relief valve, pressure switch, and motor switch functional checks were omitted. Coupling leak checks and check valve internal leak valve checks were omitted. Signal conditioner checks, for density and temperature signals, were omitted. Verification of these matters was left for and accomplished in oxygen system tests at higher levels of CM and SM integration. The shelf was then installed (fig. C4-55). The upper one of the two accepted bent tubes shows at the extreme right of the figure. The lower one, bent 7 degrees as it joins the back of the fuel cell valve-module, is in the lower right corner.

In December 1968, after concern for a possible oil contamination of facility lines, GSE hose connections were checked for contamination and found acceptable. Vent line samples taken later, at KSC during cryogenic tanking, verified that no contaminants reached the spacecraft interfaces.

Engineering requests for recalibration of the oxygen system pressure instrumentation and the oxygen quantity signal conditioner of the assembly were responded to in January and February, 1969.

Final inspection and cleanup of the shelf in the service module was accomplished on May 27, 1969. The oxygen SSAD book was signed off June 6, 1969, and SM 109 was shipped to KSC.

Transportation from North American Rockwell to KSC.- Shipment of SM 109 from Downey to KSC was accomplished by the normal means, horizontal mounting on a vibration isolating pallet carried on ground vehicles and a Super-Guppy aircraft. No shock was observed in the instruments carried.

Kennedy Space Center.- The oxygen tank and shelf assembly participated in normal service module tests beginning with the Combined Systems Test. Test and checkout flow at KSC are shown chronologically in figure C4-56.

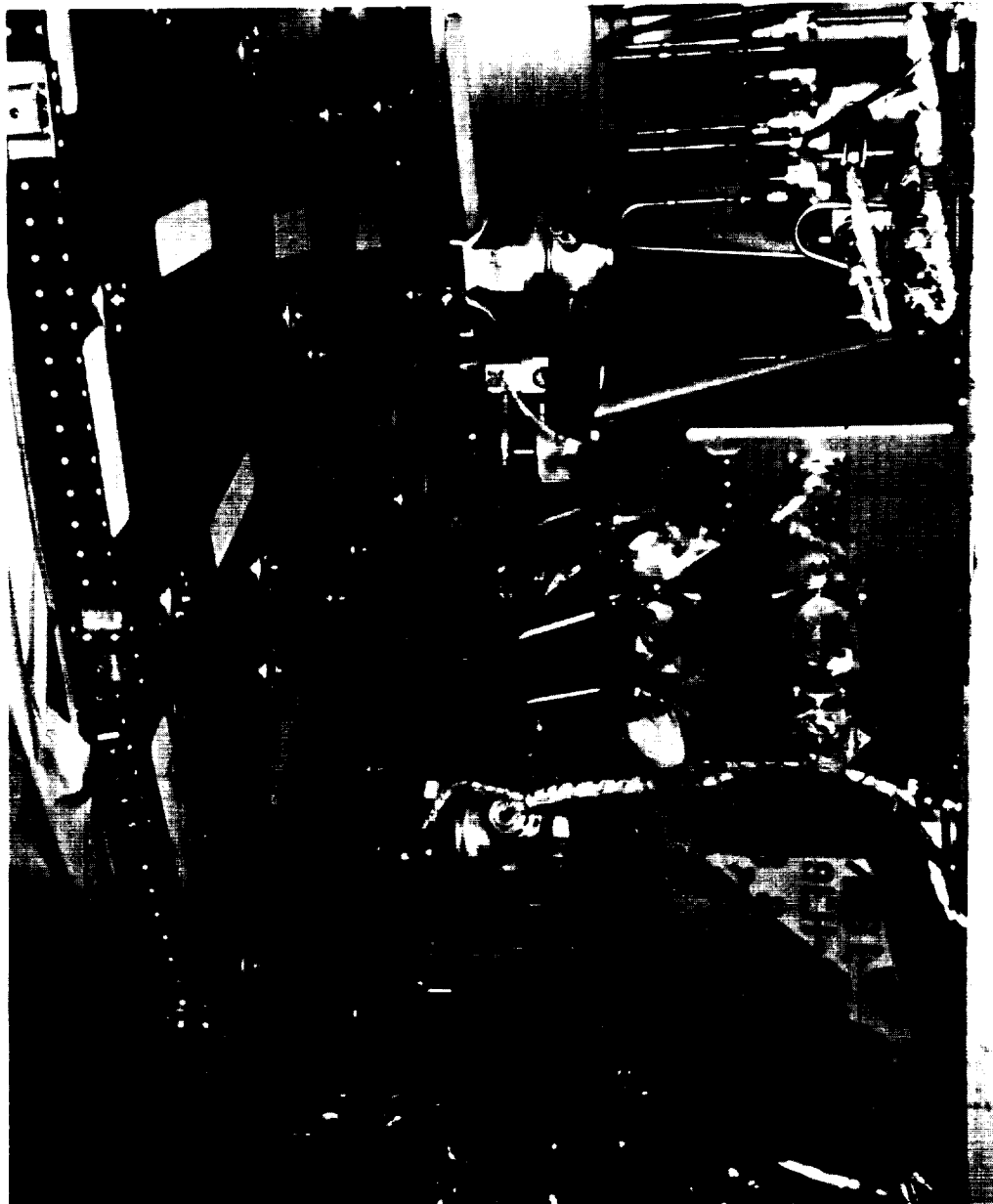

Figure C4-55.- Oxygen shelf installed in service module.

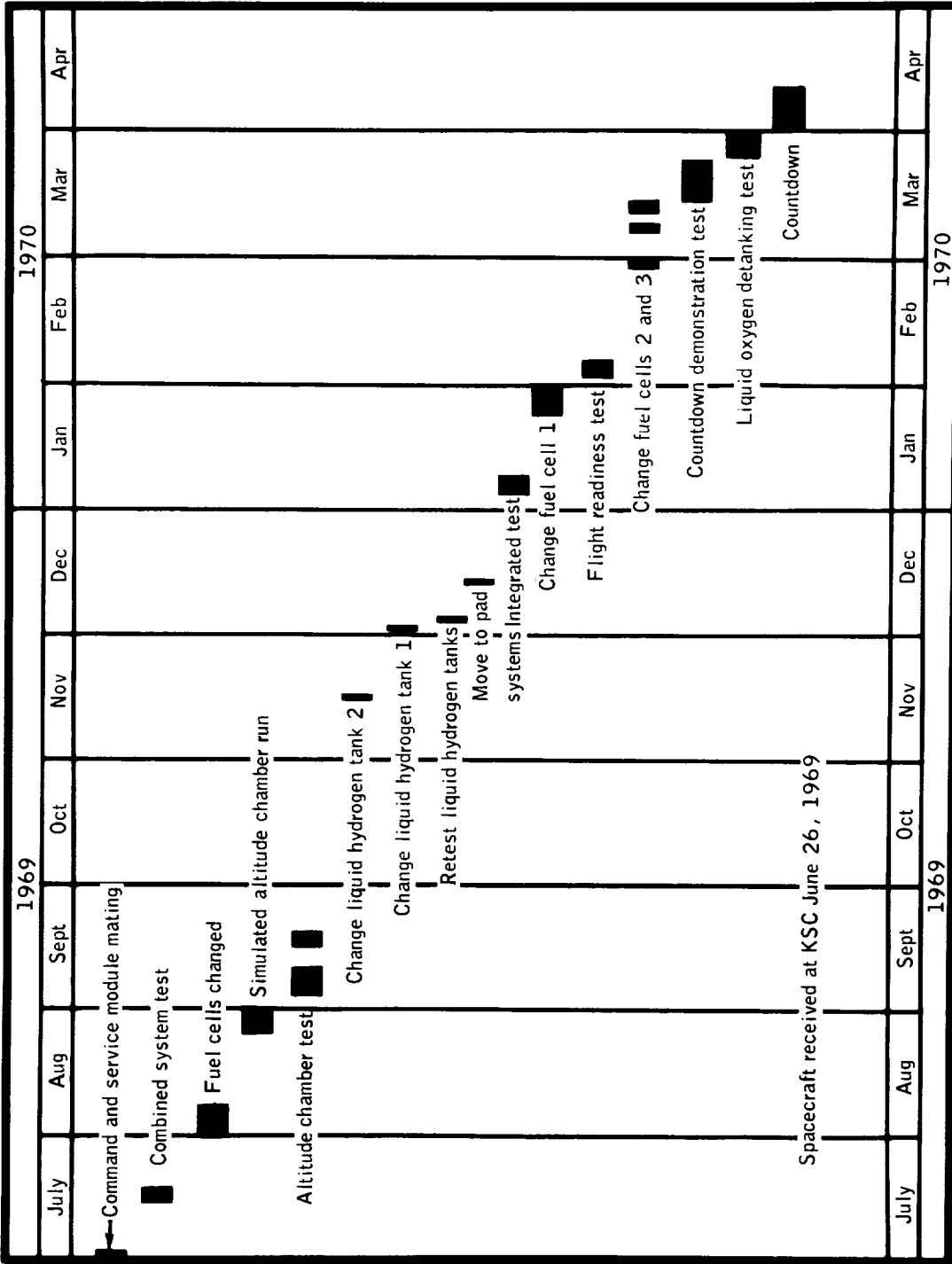

Figure C4-56.- Test flow for oxygen shelf at KSC.

A leak check was performed July 18, 1969, using helium at 94 psia in oxygen tank no. 2. Tank no. 2 was pressurized to 1025 psia to establish the relief valve cracking pressure and to verify the pressure switch operation. The pressure was decreased to 870 psia and then increased to 954 psia during the first integrated test with the launch vehicle simulator. The oxygen tanks no. 1 and no. 2 were evacuated to less than 5mm Hg, to dry the tanks, then pressurized to about 80 psia with reactant grade gaseous oxygen. Instrumentation was verified and fan motors were checked out.

A progress photograph (fig. C4-57) taken at KSC on November 14, 1969, shows the visible condition of the oxygen shelf with tanks, valves, tubing, and cables.

During the Flight Readiness Test in early February 1970, the pressurization cycle was repeated; vacuum to 5mm Hg and oxygen pressure to about 80 psia.

At the CDDT in March after activation of the fuel cells, the same cycle was followed: vacuum of the oxygen tanks to 5mm Hg followed by a gaseous oxygen pressure of about 80 psi. After the cooling of the fuel cells, cryogenic oxygen loading was normal and tank pressurization to 331 psia by using heaters powered from 65 V dc ground power supply was completed without abnormalities.

During these CDDT operations on March 23, tank no. 1 was detanked to the normal 50 percent within less than 10 minutes. Over the space of 45 minutes, tank no. 2 did not detank normally but was observed to retain more than 90 percent of its oxygen. Detanking was suspended until the completion of CDDT.

On March 27, detanking of tank no. 2 was again attempted. The tank had self-pressurized to 178 psia with a quantity of 83 percent indicated. By opening the fill line valve the pressure was depleted to approximately 36 psia in about 13 minutes. The quantity indication went down to about 65 percent (see fig. C4-58).

Next, during detanking attempts for both tanks, a comparison of tank no. 1 and tank no. 2 performance was made. The indicated oxygen quantity of tank no. 1 depleted from 48 percent to zero in less than 10 minutes. The indicated quantity in tank no. 2 remained above 60 percent over a 20-minute period.

Attempts were made over an 80-minute period to deplete the oxygen content of tank no. 2 by cycling up to various pressures and down, but did not reduce the indicated quantity below 54 percent (fig. C4-59). An attempt was made to expedite oxygen expulsion through the use of the tank heaters operated at maximum voltage and the fans. These were turned on for nearly 6 hours while the vent port remained open (fig. C4-60). Still the indicated quantity remained above 30 percent.

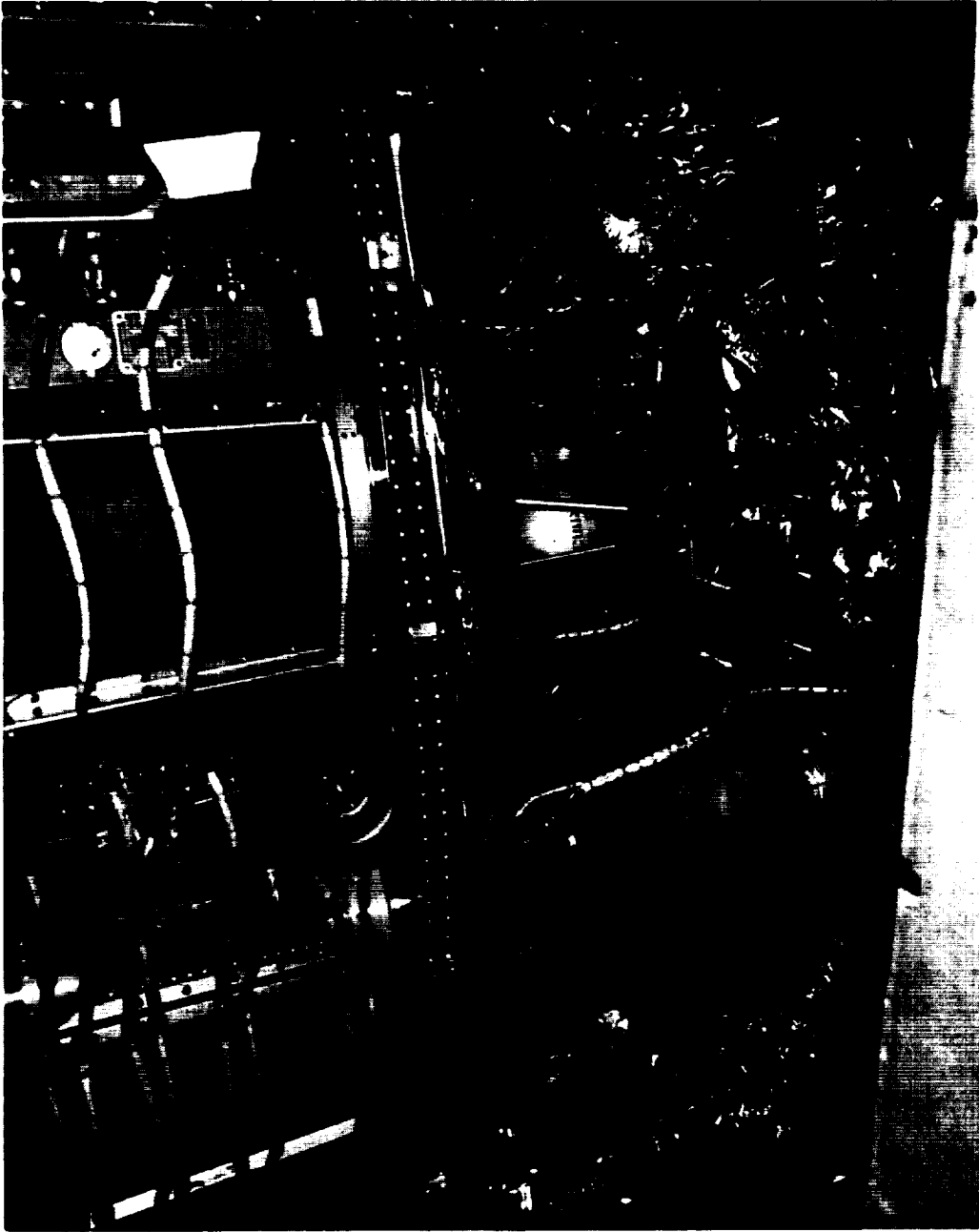

Figure C4-57.- Progress photograph of oxygen shelf taken at KSC
November 14, 1969

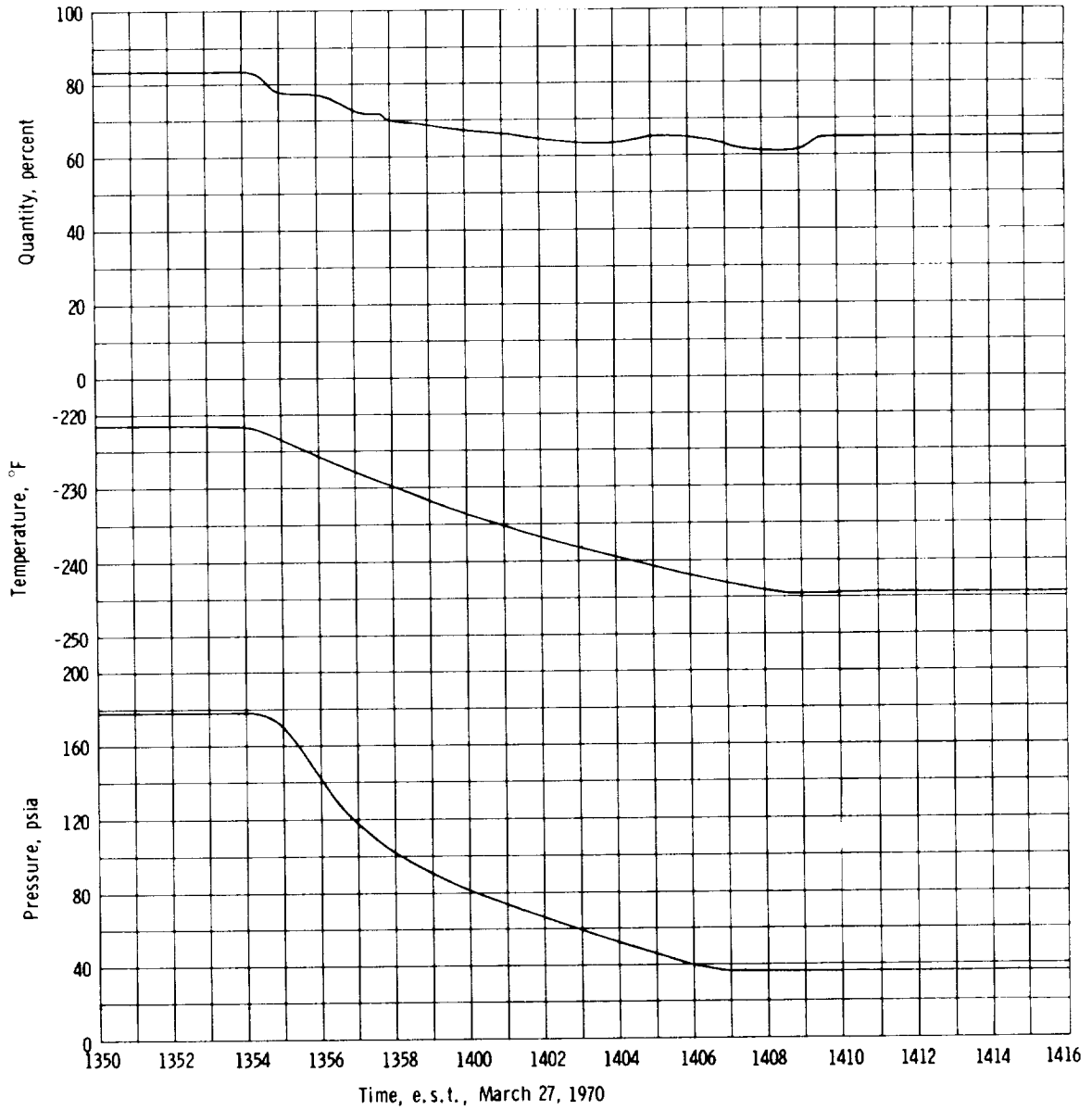

Figure C4-58.- Oxygen tank 2 detanking characteristics (pressure decay through the fill line - CDDT).

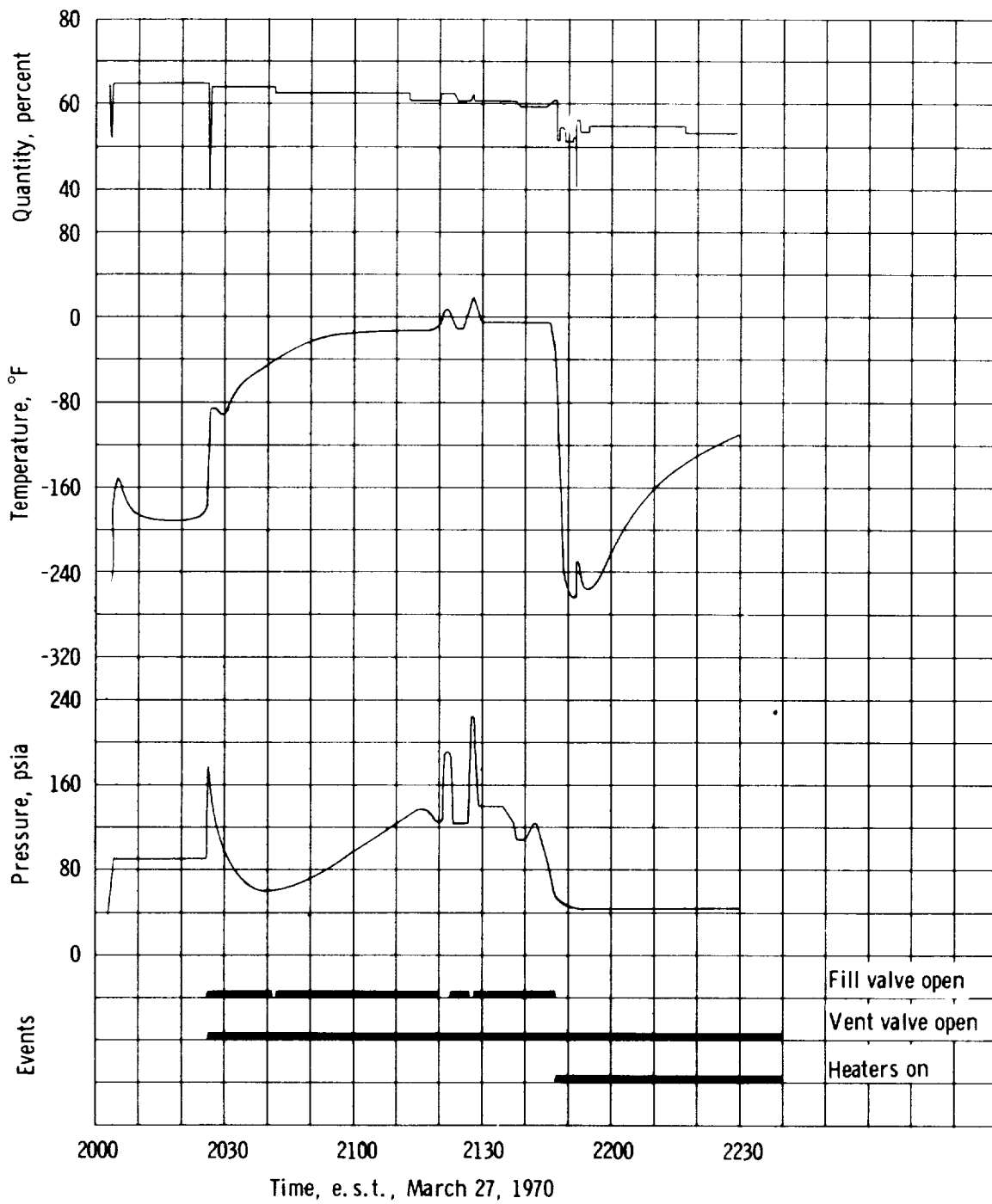

Figure C4-59.- Oxygen detanking attempt using varying purge pressure.

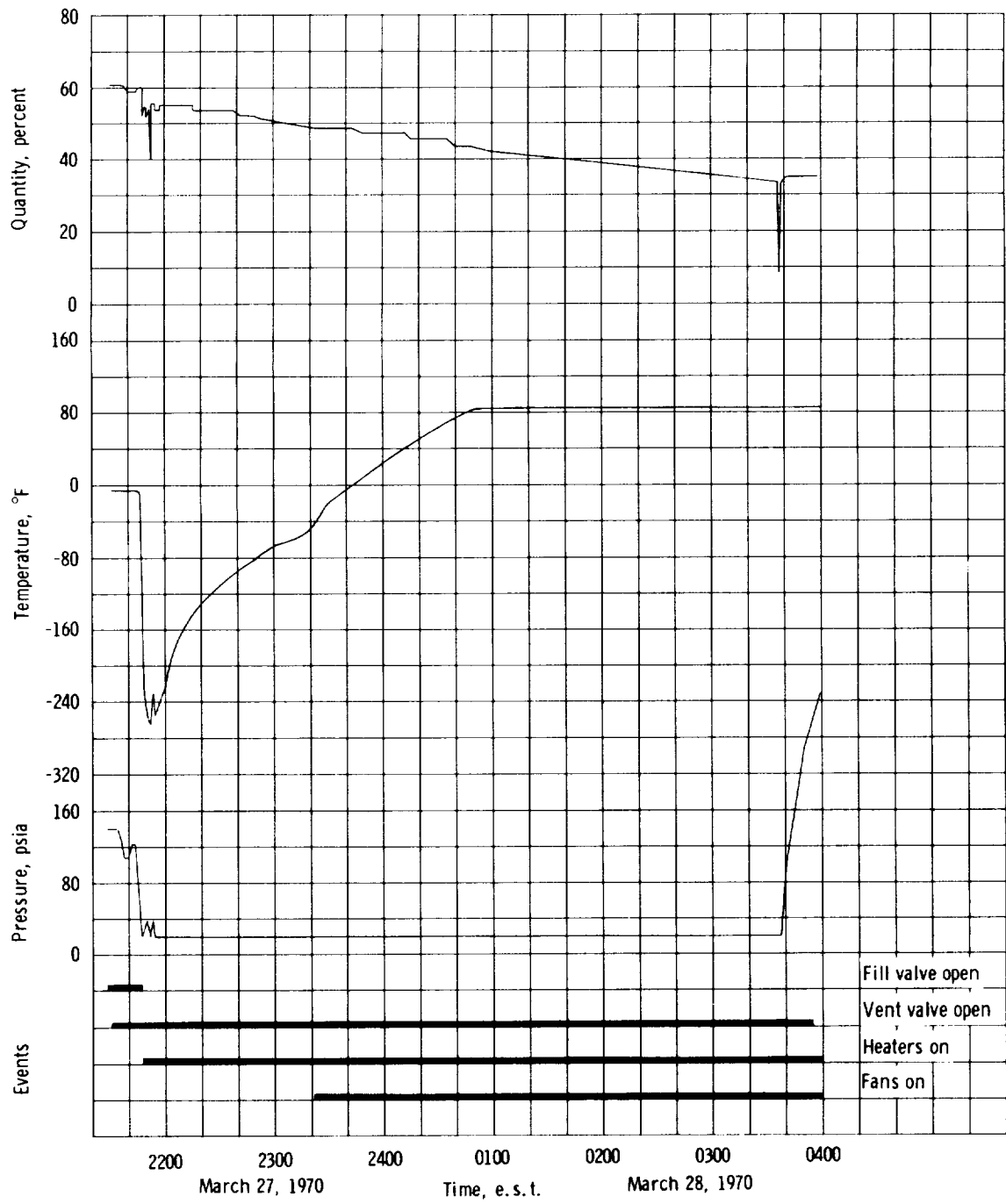

Figure C4-60.- Oxygen detanking attempt using tank heaters.

Then a pressure cycling technique was employed over a 2-1/2 hour period with maximum power being applied continuously to both tank heaters and fan circuits (fig. C4-61). This technique involved raising the tank pressure by external gaseous oxygen to approximately 300 psia and then opening the fill line to induce rapid boil-off. After five cycles, the oxygen tank quantity indicated zero.

Fan responses were observed to be normal throughout these operations. The temperature sensor on the quantity probe reached its indicating limit (+84 F) halfway through the 6-hour heating period. No observations of whether the heaters cycled on and off were made and subsequent review of the power supply voltage recording showed no indication of heater cycling.

Concern developed over two alternate hypothetical tank no. 2 conditions, a leakage path in the fill line within the tank or a clogged fill line.

Gaseous flow tests were used in one attempt to evaluate the latter. Both tank no. 1 and tank no. 2 were pressurized to approximately 240 psia and blown down through the fill lines with no significant differences in blowdown time (fig. C4-62).

A check of the Wintec filter in the GSE for oxygen tank no. 2 was made by the Wintec Corporation. No significant foreign material was found.

The alternate hypothesis, that the short segments of fill tube in the top of the quantity probe of tank no. 2 had large gaps or had become dislodged, was considered as were the operational difficulties associated with the use of a tank in this condition. The concern here was that the loading process might be hampered by the position of the fill line parts. It was noted that the filling was normal for the CDDT.

To verify this judgment and to assure countdown operability, both tanks were filled on March 30 to about 20 percent in approximately 2.5 minutes. Tank no. 1 detanked normally; tank no. 2 did not. Again the procedure of applying heat at maximum voltage and the cyclic application of gas pressure of approximately 250 psia and then venting was used. Five cycles were applied in a 1-1/4 hour period and tank no. 2 was emptied (fig. C4-63). The fan responses were observed to be normal and no indications of heater cycling were observed.

During the countdown, April 8, 1970, the pressurization of oxygen tank no. 2 was hampered by a leak through the vent line pressure-operated disconnect. Installation of the first cap stopped the leak and the pressurization of tank no. 2 was normal with no anomalies noticed during the completion of the countdown.

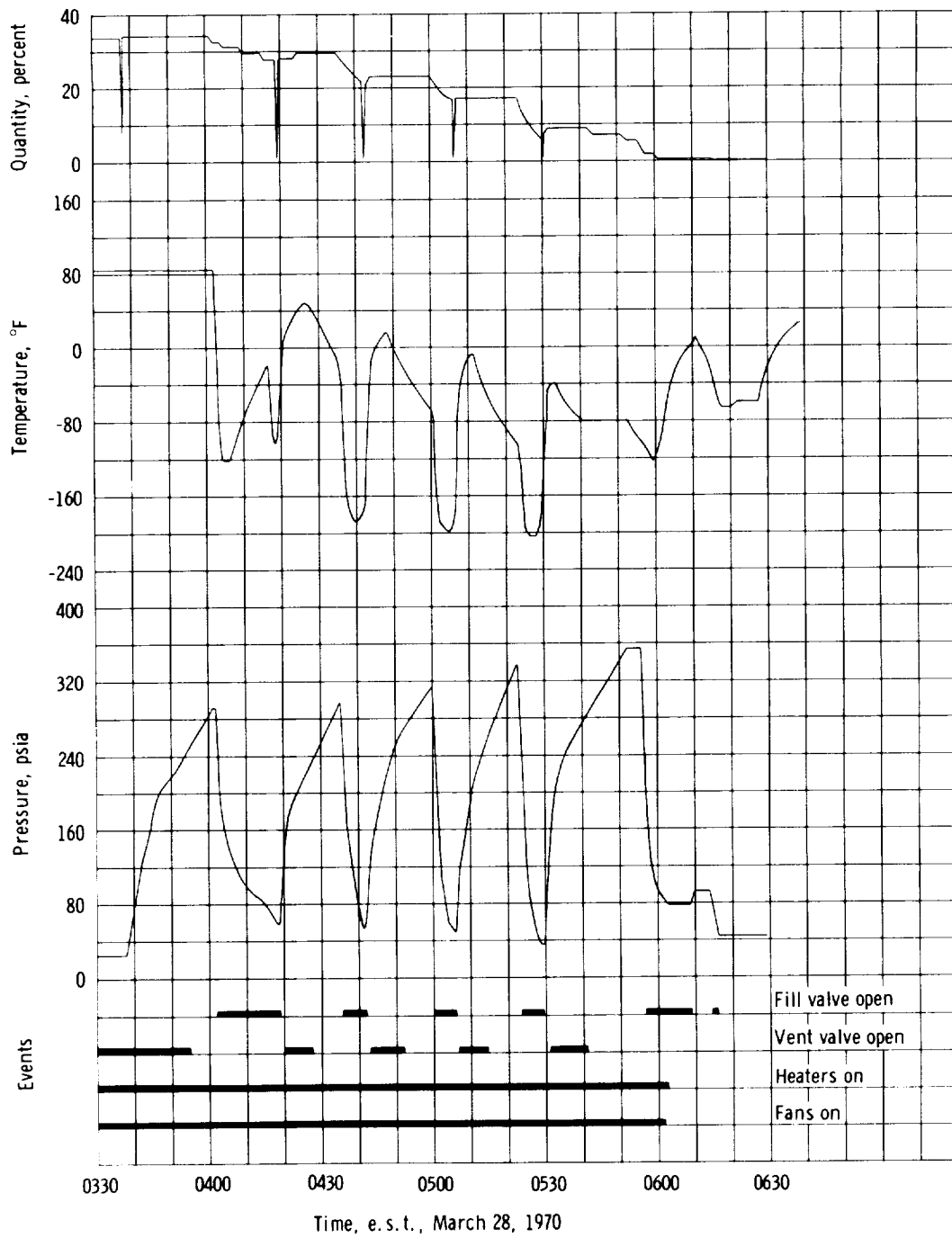

Figure C4-61.- Oxygen detanking using pressure cycles and tank heaters.

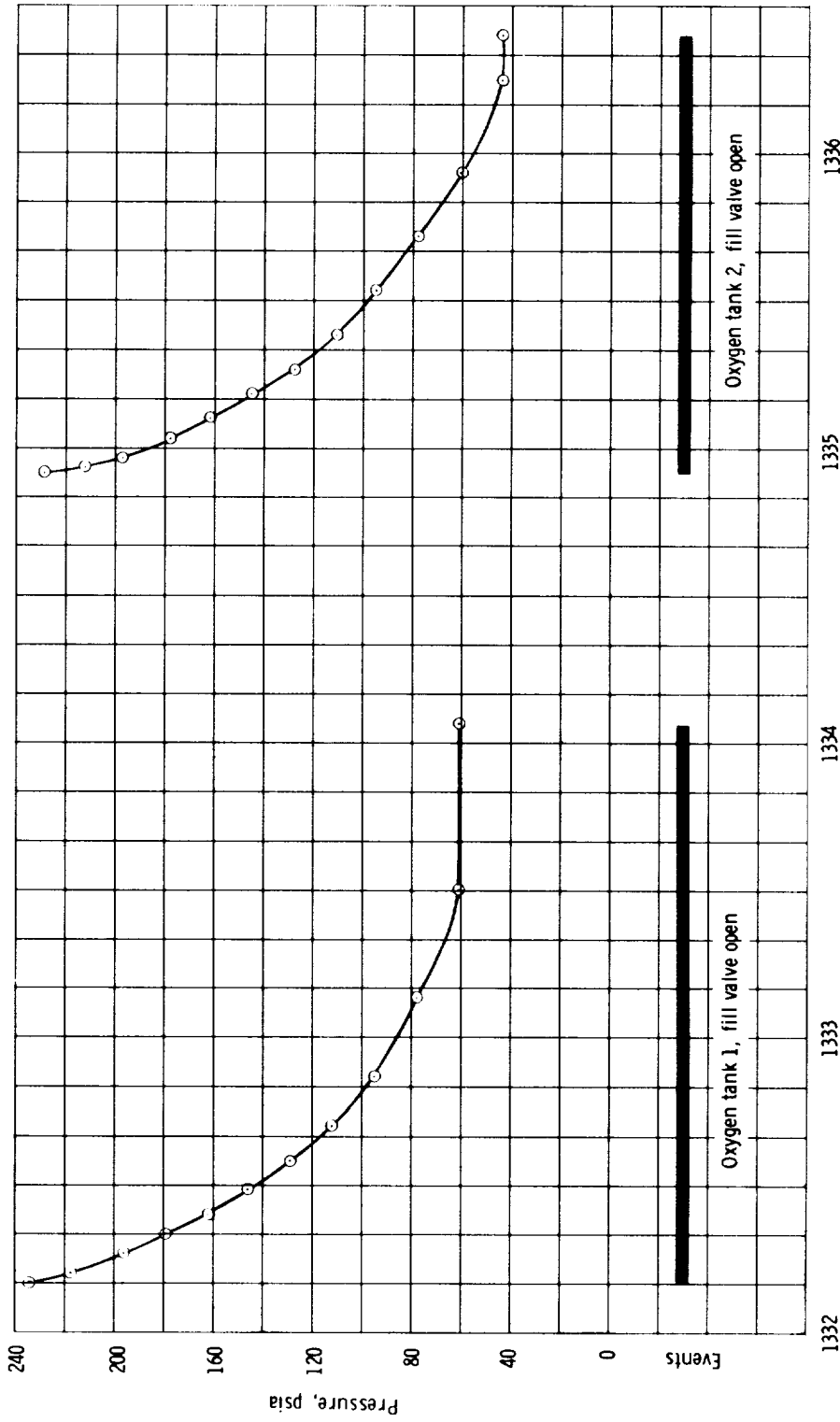

Figure C4-62.- Gaseous oxygen blowdown test, spacecraft 109.

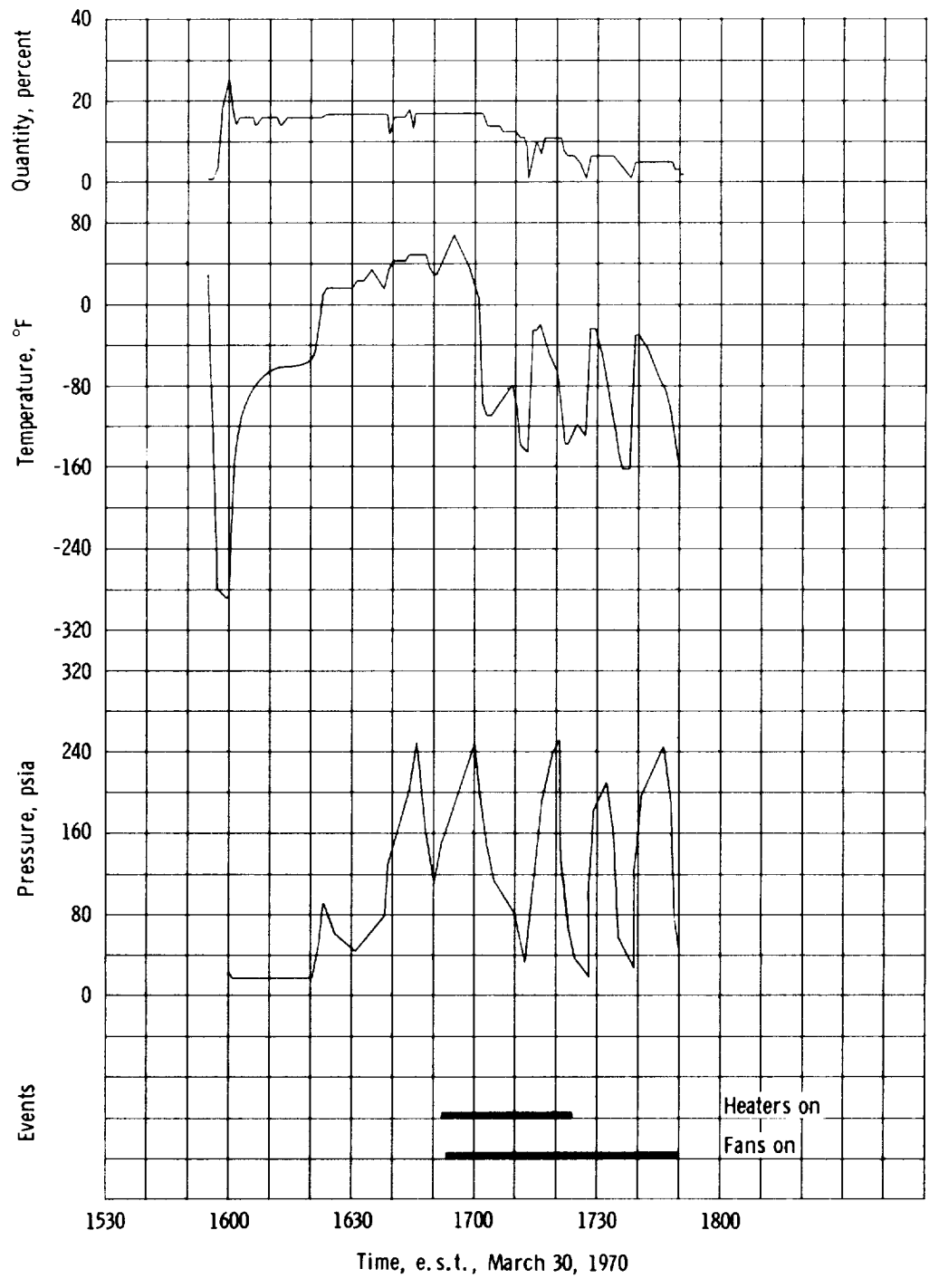

Figure C4-63.- Oxygen detanking using pressure cycles and tank heaters.

Several items of overall tank test and checkout experience should be noted.

Contaminants: Liquid, as well as gaseous, oxygen which entered tank no. 2 was verified by sample analysis. Nothing indicates that contaminants did enter the oxygen tanks. The samples taken from the vents during the servicing met the specification requirements and did not give an indication of tank contamination.

Quantity probe: Throughout all tests, during a period of 11 months resulting in 167 hours 8 minutes operating time including 28 fan on/off cycles over the 17-day period of CDDT and launch count, the quantity gaging system in tank no. 2 exhibited less sensitivity to noise and transients than that of tank no. 1.

Oxygen tank no. 2 pressure cycling: At no time during the testing of oxygen tank no. 2, in systems and subsystems, were the specified pressure limitations or allowable tank cycles exceeded.

Testing of oxygen tank fans: Test records were reviewed of all fan motor operations at KSC for any indications of ac bus transients. Tank no. 2 fans were powered 30 times. No electrical transients were found except those normally connected with fan starting or stopping. Fan motor performance was considered normal.

Investigation and Supporting Work

Causes of detanking difficulties.- Review of information from the Beech acceptance test logs and review with the Beech personnel in charge of these tests does not indicate that the detanking was abnormal. Contrarywise, the data are not substantive to prove that the liquid was expelled through the fill line. No weight or quantity measurement is recorded at the completion of the liquid expulsion; however, the procedure calls for continuing the application of vent line pressure until both the weighing system and the quantity probe indicate the tank is empty. The final tank empty condition is based on the final exit temperature of the warm nitrogen gas purge. At the time, no one indicated that the response of the tank to the procedures was anything but normal, and today careful review of existing data, discussions with the responsible Beech Aircraft and North American Rockwell personnel, and a special test at Beech Aircraft indicate that the detanking of the 0008 tank was most probably normal.

Each oxygen storage tank is stored at NR, Downey, in its shipping container until removal for installation in the assigned oxygen shelf. Thus it is retained in a vertical position until any motion takes place in the shelf assembly fixture.

The shelf assembly fixture used at Downey (fig. C4-50) aligns tank no. 1 so that the fill tube segments in the top of the quantity probe assembly lie nominally in a plane transverse to the axis of fixture rotation. Thus the fixture in the normal position holds the tubes upright but otherwise can rotate them through a full circle, exposing them to dislodging forces in the plane of their nominal location. The situation for tank no. 2 is nearly a right angle to the tank no. 1 situation so that the tube segment plane is nominally parallel to the trunnion axis of the assembly fixture. Thus in all positions other than vertical or inverted, a lateral dislodging force exists relative to the plane of their nominal location.

The highest elevation of the tank assembly, and thus the first area of contact with the underside of the fuel cell shelf at the time of the lifting fixture breakage and the shelf dent, was the cover over the upper vacuum pinch-off tube (fig. C4-55). This point was to the left of the mass centers and lifting forces involved as the counterbalance rotated and broke away from the fork portion of the lifting fixture. (See Appendix D.) Some rotation to lift the outer right corner of the shelf (lower right in fig. C4-55) higher than the outer left would be expected from this configuration. An uneven fall to the shelf supports would follow.

In figure C4-55, showing the installation of the oxygen shelf in SM 109, the condition of the farthest right tubing in the lower part of the picture reflects the comments of two DR's that one tube had a "slight bend" at the valve module and another (lower) was "badly bent." As the highest tubes, farthest from the 11th bolt and the high point of tank no. 2, these two may have participated in the "shelf drop" incident. Neither was found to be in need of repair after leak check.

No mention could be found in review of these DR's of any concern for the condition of the tubes, wires, or motors internal to the oxygen storage tank except as verifiable through routine external gas and electrical testing with NR factory OCP's.

Shipment of SM 109 from NR/Downey, with the SM axis horizontal during ground and air transportation, afforded the next major opportunity for fill tube segment lateral dislodgment.

It appears pertinent to this review to note that during SM transportation the fill tube segments within the upper portion of the oxygen tank no. 2 quantity probe assembly lay with the tank-exit end of the fill tube segments about 20 degrees above the horizontal, if they were still in place after previous handling and the "shelf drop." Neither the wires nor the feed line filter were below it to restrict rotation of the fill tube about the central tube of the quantity probe (fig. C4-64).

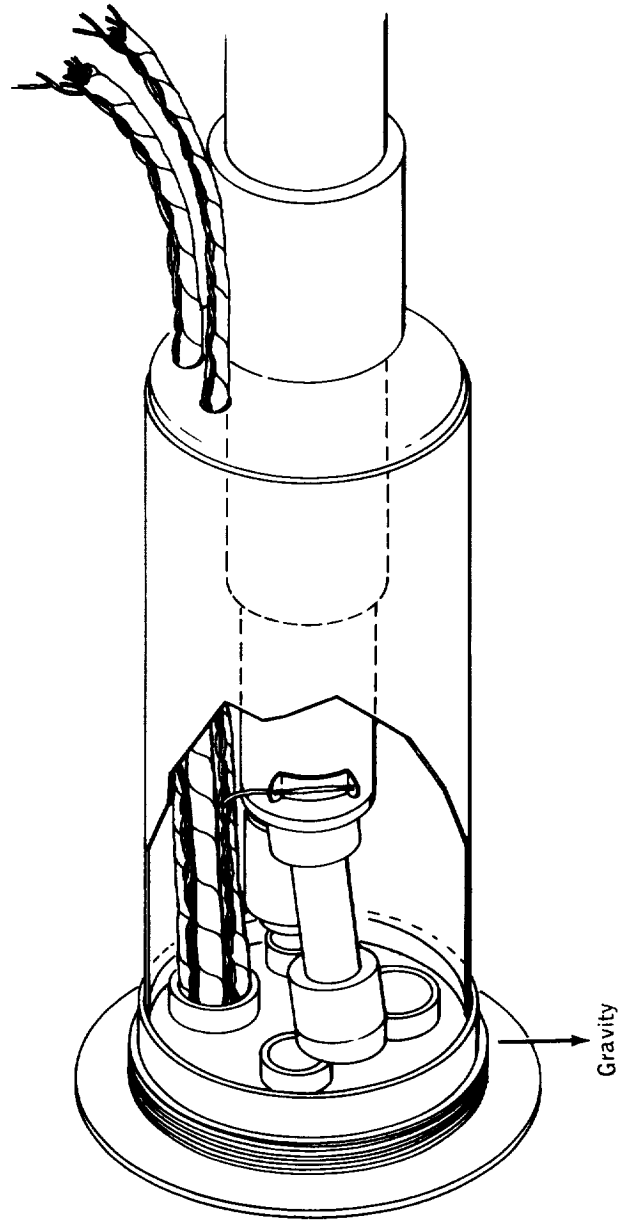

Figure C4-64.- Isometric sketch of quantity probe head as oriented during SM transportation.

This history of exposure of the tank fill tube segments to an unusual dislodgment environment sequence was not recorded during the detanking incidents at KSC nor during the presentation of CSM 109 history reviews to the Apollo Spacecraft Program Manager through either reliability and quality assurance or engineering channels at MSC. However, it does corroborate the recorded real-time judgment of Beech, MSC, and KSC engineers that the tank fill line parts may have been out of place in tank 10024XTA0008 during the detanking problems of March 23-30, 1970.

Since the fill tube parts have dimensional tolerances that could allow these parts to fall out of place, a calculation was made to attempt to establish the configuration of the tank during the detanking operations at KSC. The data from the first detanking attempt of March 27 were used to test the hypothesis that the fill tube parts were disconnected such that no liquid was expelled from the tank. A simple heat balance equation of the tank from the initial condition to the end condition shows that all the mass lost by the tank can be explained by vaporization and it is likely that no liquid was expelled. Figure C4-58 and table C4-III show the data upon which these calculations were based. At the initial and final point the temperature indicated in the data is too warm for the pressure indicated. The saturation temperature was used for each case.

Possible effects of special detanking procedures at KSC.- The use of special detanking procedures at KSC to empty tank no. 2 of CSM 109 has created concern these special procedures may have altered significantly the condition of the oxygen tank.

A number of special tests have been run and other tests are yet to be run in an attempt to determine the nature and degree of degradation that may be expected to occur to the tank internal components and wiring resulting from exposure of this type. The most significant finding to date is the fact that the thermostats fail by welding closed almost immediately when attempting to interrupt 65 V dc.

Several tests were run to determine the temperature that would occur at various points on the heater tube as a result of operation at ground power level as the liquid in the tank is boiled off. These tests were run at MSC using a similar sized tank with an actual flight-type heater fan assembly. The test setup is shown on figure C4-65. Liquid nitrogen was used in the tank for safety reasons. The initial run was made with a later model heater fan assembly that does not utilize thermostats; however, it was felt that as long as liquid nitrogen was present it was not likely that the thermostats would be called upon to operate. During this test very high temperatures were encountered on many locations on the heater tube (figure C4-66). These conditions were considered to be very unrealistic, so the test was rerun using a heater fan assembly equipped with thermostats. When the test was started, one thermostat indicated an open circuit at the initial fill condition. It was decided that a satisfactory test could be run since an extra lead had been extended from the heater elements so that the heaters could be manually operated to coincide with the functioning of the operable thermostat.

TABLE C4-III.- THERMODYNAMIC BALANCE CALCULATIONS

	Initial condition	Final condition
Quantity, lb	274 (83% indic.)	212 (65% indic.)
Pressure, psia	178	36
Temperature, ° F	-236.5	-280
Temperature, ° R	223.2	179.7
Density of liquid, lb/ft ³	58.4	68.0
Volume of liquid, ft ³	4.70	3.10
Volume of gas, ft ³	.05	1.65
Weight of liquid, lb	273.85	210.9
Weight of gas, lb	0.15	1.1
Enthalpy of liquid, Btu/lb	88	68
Enthalpy of gas, Btu/lb	158	155
Total enthalpy of liquid, Btu	24,112	14,341
Total enthalpy of gas, Btu	24	171
Heat capacity of metal, 44 lb $\Delta T^\circ = 43.5^\circ \text{ F}$, sp. ht. 0.086	(Reference Cond.)	-164
Heat capacity of boil-off gas 62 lb at 156.5 Btu/lb	<u>0</u>	<u>9,703</u>
Total enthalpy, Btu/lb	24,136	24,051

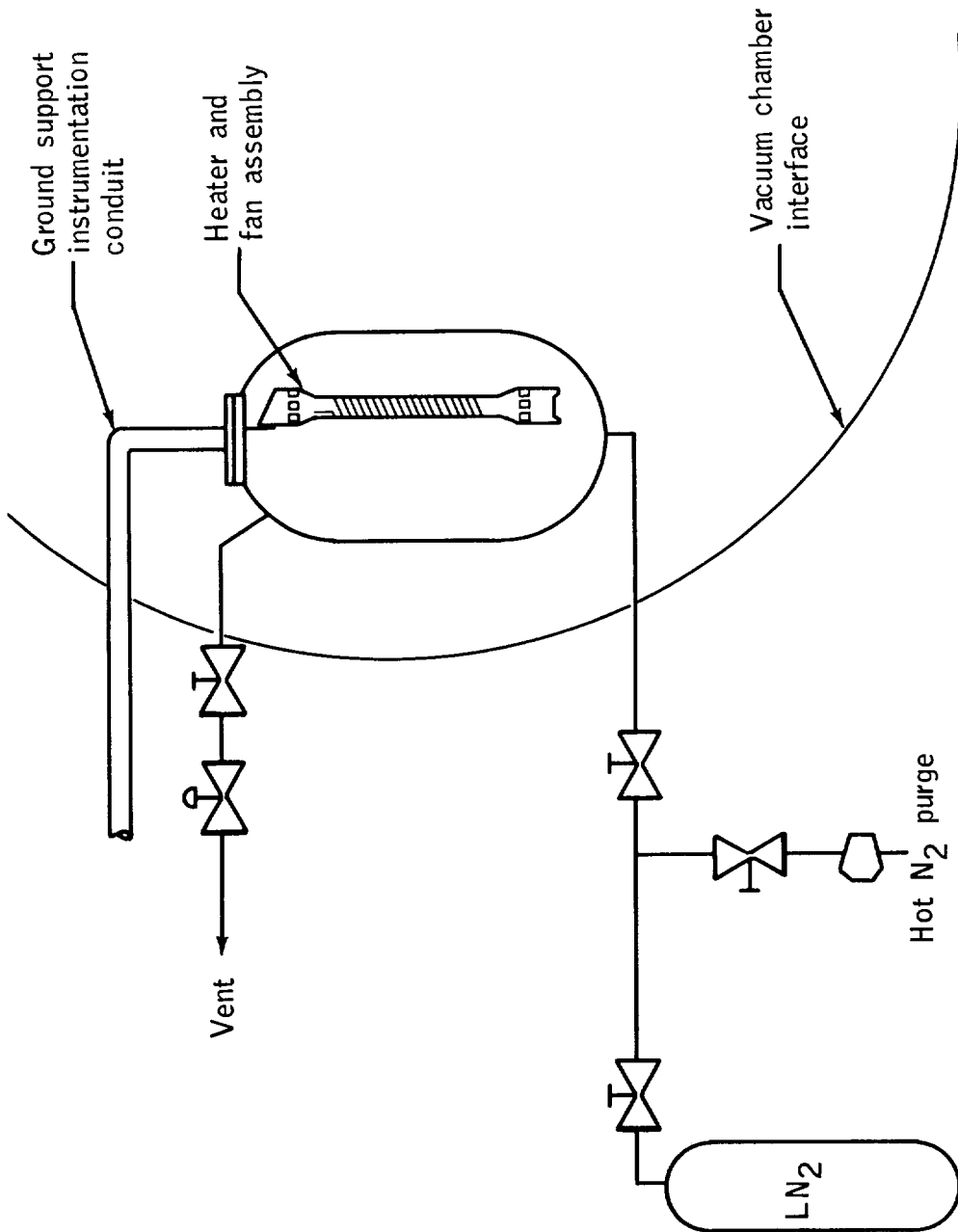
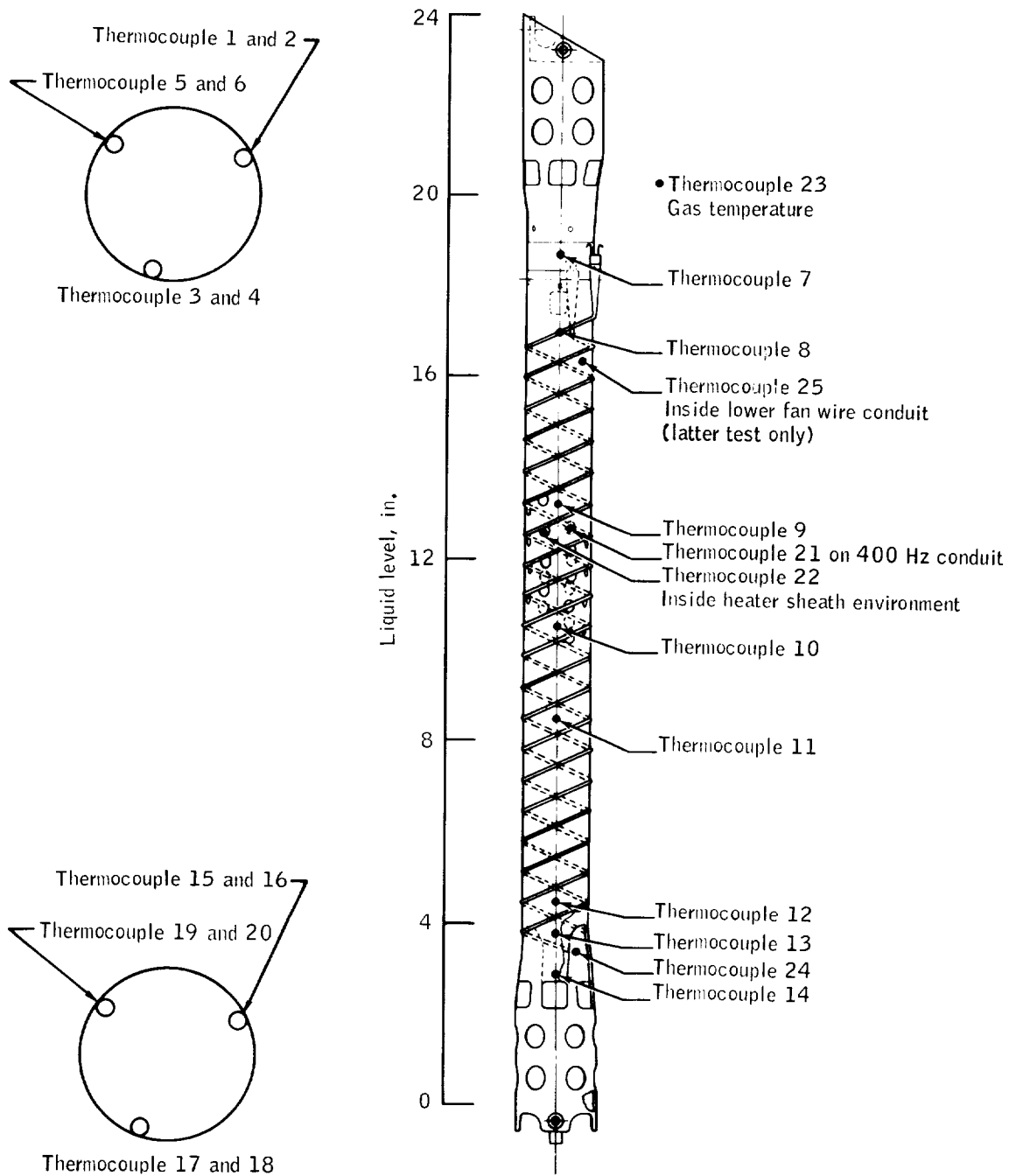
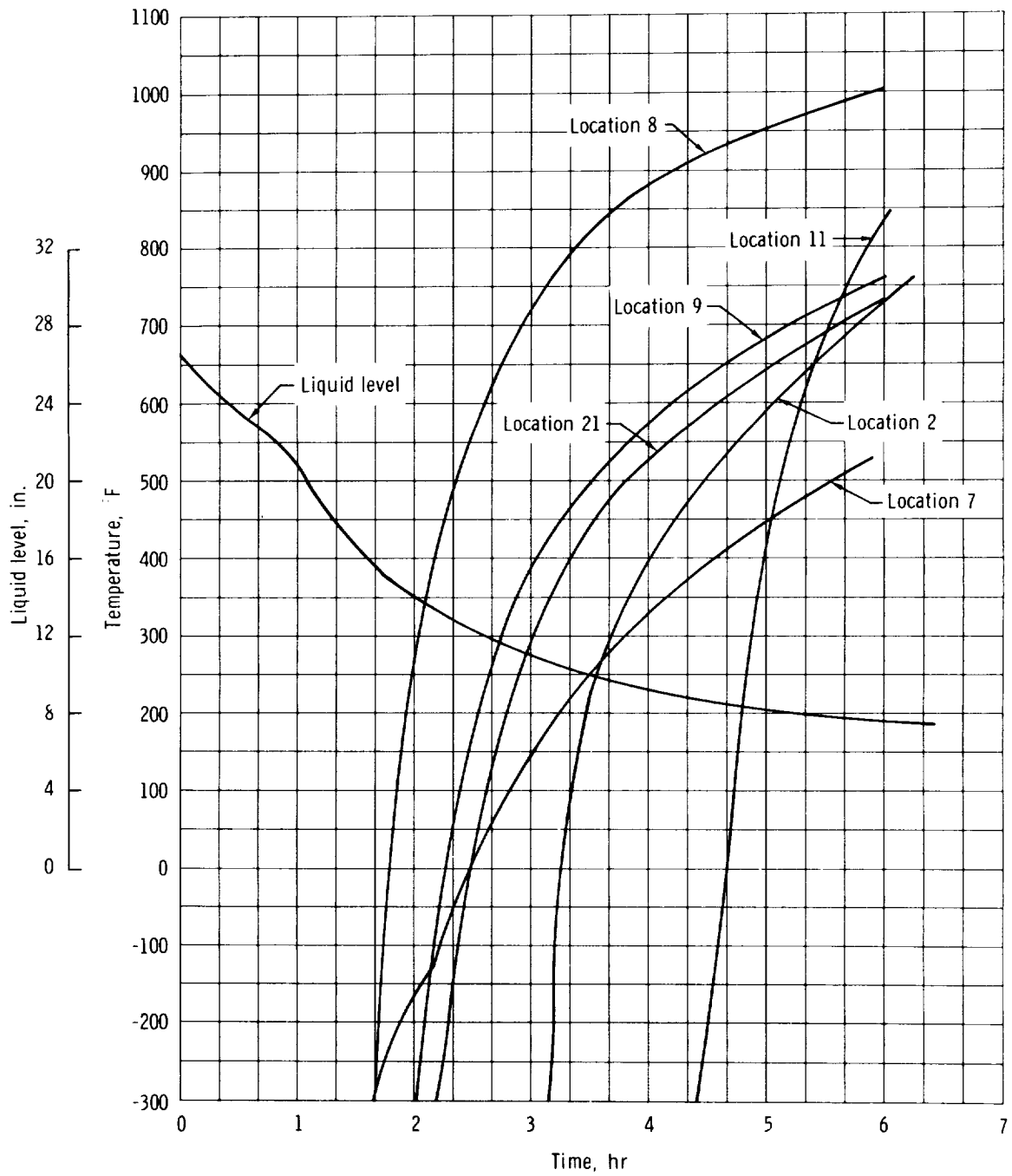

Figure C-4.65.- Heater tube assembly temperature test setup.



(a) Temperature sensor locations.

Figure C4-66.- Heater tube assembly temperature test.



(b) Typical test results.
Figure C4-66.- Concluded.

The test was started and after a few cycles in this mode the previously nonfunctioning (open) thermostat started indicating normal function. At this time it was decided to revert to the originally intended test configuration, i.e., the thermostats directly controlling the heaters. Data from that point on indicated that the thermostats were not cycling the heaters. The heater tube temperature data looked just like the nonthermostat test run. The test terminated at this point and the thermostats were removed and X-rayed. The X-rays indicated that the contact gap was bridged. One thermostat had its case carefully removed to examine the conditions of the contacts (fig. C4-67).

A review of the thermostat design and the manufacturer's ratings indicate that the thermostats are severely overloaded in current-interrupting capability at the ground power condition. Open contact spacing at 65 V dc is such that a sustained arc can be established and the contacts melted at this first attempt to interrupt power of this magnitude.

Inasmuch as thermostat failure would be expected at the first attempt to interrupt the ground power level, the conditions of heater tube temperature measured during the first test of this series would be indicative of those experienced during the KSC special detankings of March 27, 28, and 30. Since a review of the heater ground power supply voltage recordings made during the special detanking operations showed no indication of heater cycling, a special postflight test was conducted at KSC which showed that the cycled load equivalent to the heaters would cause a cycling in the voltage recording. Figure C4-68 shows sections of motor lead wire removed from the heater tube conduit.

Other tests run at Ames Research Center (see Appendix F) indicate that Teflon-insulated wires run at similar temperatures in an oxygen atmosphere result in even more severe degradation.

A test is being run at Beech Aircraft to simulate all the tanking and detanking conducted on XTA-0008 at KSC. A Block I tank modified to the Block II configuration with the fill tube connecting parts rotated out of position is being used for this test. Temperature measurements on the electrical conduit in the vacuum dome area and posttest inspection will be utilized to evaluate the effects on the wiring of the special detanking operations.

At no time during standard checkout, prelaunch, and launch operations are these thermostats required to interrupt the 65 V dc ground power supply current. As far as could be determined, the special detanking operation was the only time that any thermostats were ever called upon to interrupt this load.

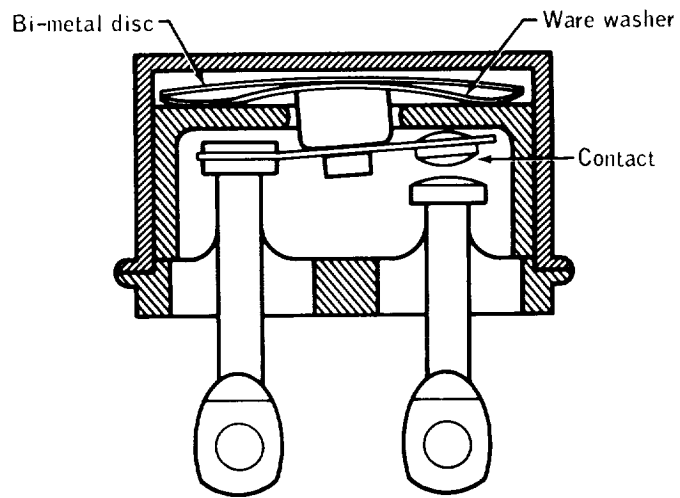

(a) Switch cross section.

Melted silver contacts



(b) Welded contacts after test.

Figure C4-67.- Thermostat configuration and welded contacts.



Figure C4-68.- Wire damage from heater tube assembly temperature test.

APPENDIX D
REPORT OF DESIGN PANEL

CONTENTS

Part		Page
	APPENDIX D - REPORT OF DESIGN PANEL	
D1	<u>TASK ASSIGNMENT</u>	D-1
D2	<u>PANEL ORGANIZATION</u>	D-3
D3	<u>REVIEW AND ANALYSIS</u>	D-5
	SYSTEM DESCRIPTION	D-5
	ELECTRICAL SYSTEM CONFIGURATION AT TIME OF ACCIDENT	D-11
	STRUCTURAL EVALUATION OF THE OXYGEN TANK	D-13
	Materials and Welding	D-13
	Qualification Program	D-20
	FRACTURE MECHANICS	D-23
	Failure Modes	D-24
	Effectiveness of the Proof Test	D-25
	Possibility of Tank Failure During Apollo 13 Mission	D-30
	DYNAMIC TESTING	D-30
	Oxygen Tank Assembly Dynamic Testing	D-30
	Apollo CSM Acoustic and Vibration Test Program	D-31
	SHOCK TESTING	D-35
	INTERNAL COMPONENTS	D-35
	Quantity Gage	D-35
	Heaters	D-37

Part	Page
Fans	D-41
Temperature Sensor	D-43
Wiring	D-43
Discussion	D-48
COMPATIBILITY OF MATERIALS WITH OXYGEN	D-48
Classification Methods	D-49
Materials Internal to the Tank	D-49
OTHER DESIGN AND SYSTEM CONSIDERATIONS	D-59
Oxygen System Relief Valves	D-59
Arrangement at Head of Tank	D-61
Dome Assembly	D-64
Filter	D-70
Caution and Warning Provisions	D-70
ABNORMAL EVENTS IN THE HISTORY OF THE OXYGEN TANK	D-71
Oxygen "Shelf Drop" Incident	D-71
Detanking at KSC	D-72
Discussion	D-74
RELATED SYSTEMS	D-78
Pressure Vessels	D-78
Line Components	D-85
Low Pressure Oxygen Systems	D-86
Electrical Power System--Batteries	D-86

Part		Page
	Ground Support Equipment	D-86
	Certification	D-87
	Apollo J-Missions	D-87
	Lunar Module "Lifeboat"	D-87
	DISCUSSION	D-87
D4	<u>SUMMARY</u>	D-89
D5	<u>REFERENCES</u>	D-93

This page left blank intentionally.

PART D1

TASK ASSIGNMENT

The Design Panel was assigned the task of reviewing the design of the systems involved in the Apollo 13 accident, including their qualification history. The service history of the specific components flown on Apollo 13 was also to be examined from a design point of view to ascertain whether any abnormal usage experienced might have had a detrimental effect on the functional integrity of the components. The Panel was also charged with review of other spacecraft systems of similar design or function to ascertain whether they contained potential hazards. Finally, the Panel was to analyze, as required by the Board, proposed failure mechanisms to the extent necessary to support the theory of failure.

The Panel conducted its activities by reviewing design documentation and drawings, historical records, and test reports; analyzing data; examining specimens of hardware; and consulting with other Board Panels and with members of the Manned Spacecraft Center (MSC) Investigation Team and the contractors.

This page left blank intentionally.

PART D2

PANEL ORGANIZATION

Panel 3 was chaired by Dr. S. C. Himmel, Lewis Research Center, and the Board Monitor was Mr. V. L. Johnson, Office of Space Science and Applications, NASA Headquarters. Panel Members were:

Mr. W. F. Brown, Jr.
Lewis Research Center

Mr. R. N. Lindley
Office of Manned Space Flight
NASA Headquarters

Dr. W. R. Lucas
Marshall Space Flight Center

Mr. J. F. Saunders, Jr.
Office of Manned Space Flight
NASA Headquarters

Mr. R. C. Wells
Langley Research Center

Specific assignments covering such areas as materials selection, fracture mechanics, materials compatibility, failure mechanisms, related systems, and electrical systems were given to each Panel Member. All Panel Members participated in the preparation of this report.

This page left blank intentionally.

PART D3

REVIEW AND ANALYSIS

Early in the proceedings of the Board, it became evident that the failure was centered in the cryogenic oxygen subsystem of the electrical power system of the spacecraft, and, more specifically, in the no. 2 cryogenic oxygen tank. For this reason, detailed examinations of the Panel were limited to this subsystem. Interfacing systems were examined only to the extent required to understand the function of the oxygen system and/or to relate data from flight or test to the operation or design of the system.

In addition, the Panel had one of its members present at the deliberations of the MSC Panel on Related Systems which conducted reviews on other Apollo spacecraft pressurized systems.

SYSTEM DESCRIPTION

The cryogenic storage subsystem supplies reactants to the fuel cells that provide electric power for the spacecraft. The oxygen system also supplies metabolic oxygen for the crew, command module (CM) cabin pressurization, and the initial pressurization of the lunar module (LM). The cryogenic storage and fuel cell subsystems are located in bay 4 of the service module (SM). Figure D3-1 shows the geometric arrangement of these subsystems within this portion of the SM. The system comprises two oxygen tanks, two hydrogen tanks, and three fuel cells with their associated plumbing, control valves, regulators, pressure switches, and instrumentation.

The uppermost shelf contains the three fuel cells; the center shelf contains the two oxygen tanks, the oxygen system valve modules, the fuel cell oxygen valve module, and a ground service interface panel. The lower shelf contains the two hydrogen tanks, one above and one below the shelf, and a set of valve modules analogous in function to those of the oxygen system.

A description of these components is contained in Appendix A of the Board's report. Also provided are the operating and design parameters of the components, materials of construction, etc.

A schematic of the oxygen system is shown in figure D3-2. The ground service lines are capped off prior to flight. Figure D3-3 is a photograph of the panel showing the terminations of these lines. The two tanks and

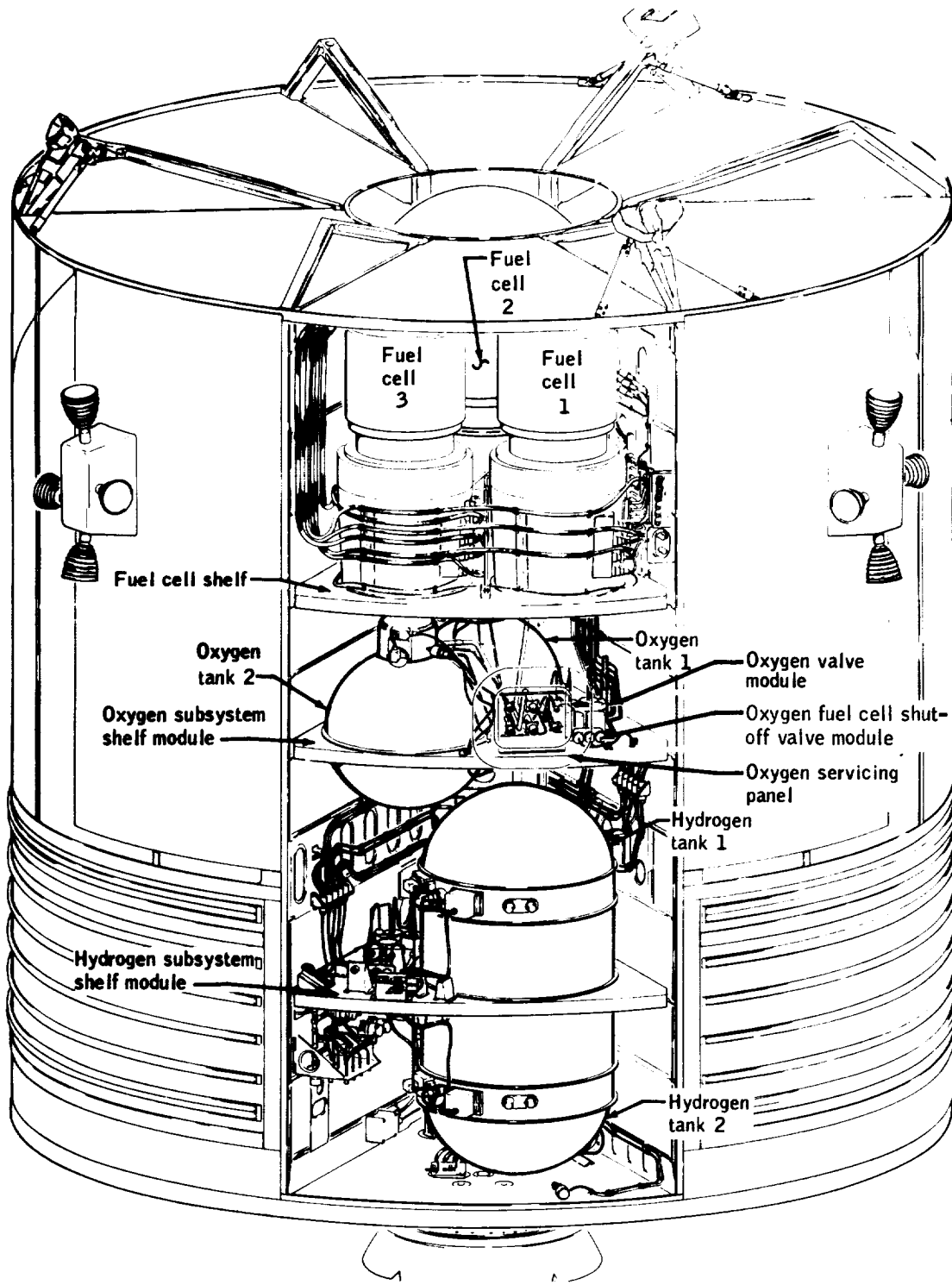
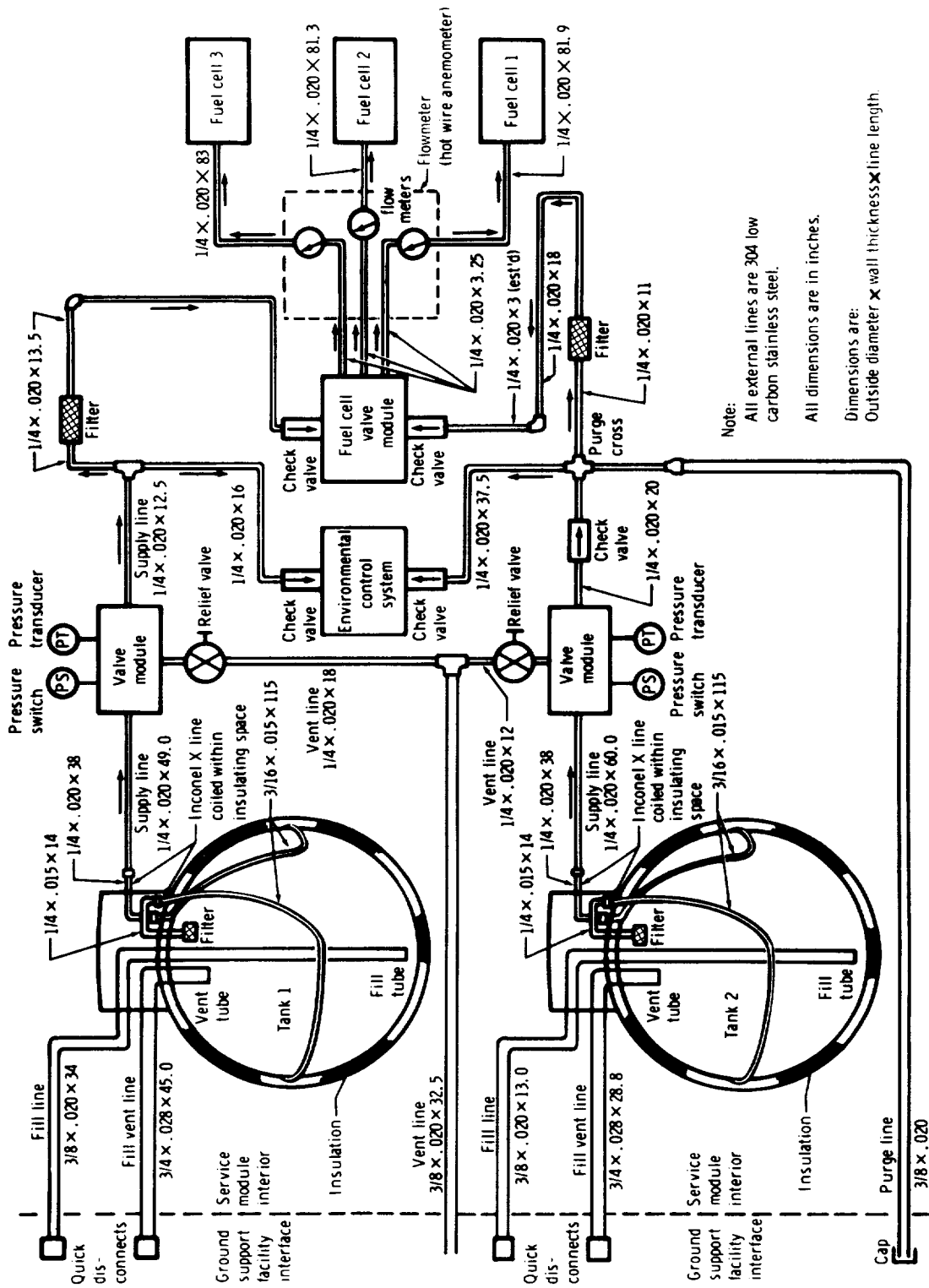

Figure D3-1.- Arrangement of fuel cells and cryogenic systems in bay 4.



Note:
 All external lines are 304 low carbon stainless steel.
 All dimensions are in inches.
 Dimensions are:
 Outside diameter x wall thickness x line length.

Figure D3-2.- Oxygen system.

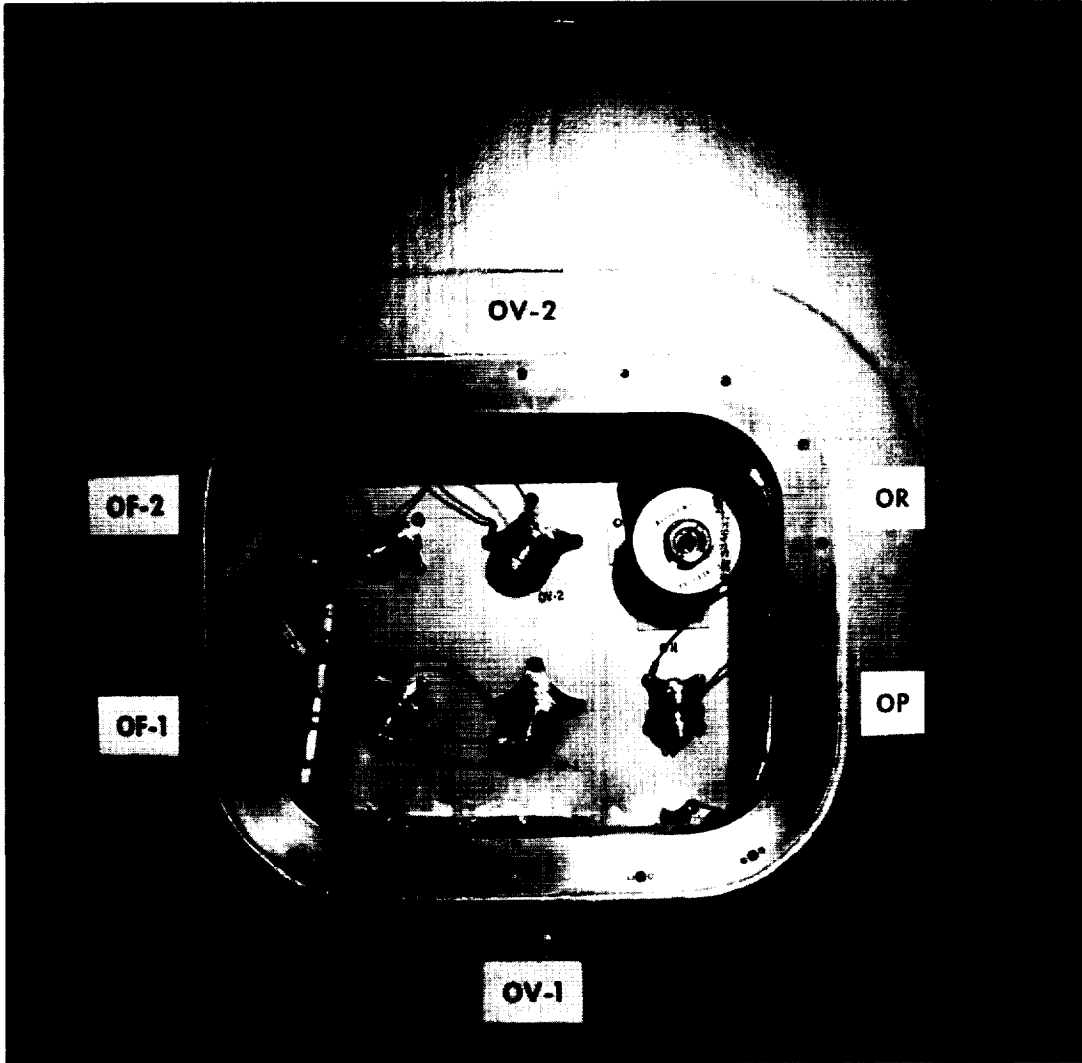

Figure D3-3.- SM oxygen system ground service panel.

their plumbing are identical except for one point in the feed line from tank no. 2, at which a ground service line tees into the feed line downstream of a check valve. This ground service line permits the operation of the fuel cells and the environmental control system (ECS) oxygen system from a ground source of oxygen without requiring the use of the flight tankage. This line terminates at the fitting designated OP in figure D3-3. The check valve prevents the pressurization of tank no. 2 from this ground source.

The pressure transducer, pressure switch, and relief valve are located in an oxygen system valve module external to the tank. A photograph of the module is shown in figure D3-4. Two of each of these components plus the check valve for tank no. 2 referred to in the previous paragraph comprise the module. Figure D3-4 shows the top of the oxygen shelf. There are approximately 19 feet of feed line from the tank pressure vessel to the valve module.

The feed line exits the oxygen system valve module and branches, one going to the ECS and the other to the fuel cell valve module where the lines from tanks no. 1 and no. 2 are manifolded within the body of this assembly. This module contains the check valves at the feed line entrance points and three solenoid shutoff valves, one for each of the fuel cells.

The cryogenic oxygen electrical system consists of the following items for each tank:

1. Two electrical heaters, rated at 77.5 watts each, 28 V dc. For ground operation, the heaters are rated at 415 watts each, 65 V dc. Four wires exit the tank connector. The wiring of the heater leads at the pressure control assembly is such that the two heaters are connected in parallel to a single power source. Power to the tank no. 2 heaters is provided from main bus B through a circuit breaker and through an on-off automatic switch. Automatic operation is provided through the pressure control assembly actuated by the pressure switches. The control logic requires that both oxygen tank pressure switches be below the low set-point to energize the heaters. Either switch sensing pressure above the high set-point will deenergize the heaters.

2. Two motor-driven fans rated at 28.4 watts each (three-phase, 200/115 V ac). Eight wires, one for each of the three power phases plus a neutral for each motor, exit the tank at the tank connector. They proceed to a fuse box assembly where each of the leads (except for the grounded neutrals) is individually fused by a 1-ampere fuse. Upon leaving the fuses, the leads from like phases of the two motors as well as the neutrals are joined within the fuse box, and four wires leave this assembly. The three power leads then pass through individual switch contacts and thence to individual circuit breakers. Each breaker is rated at 2 amperes. The fans can be operated in either a manual or automatic mode.

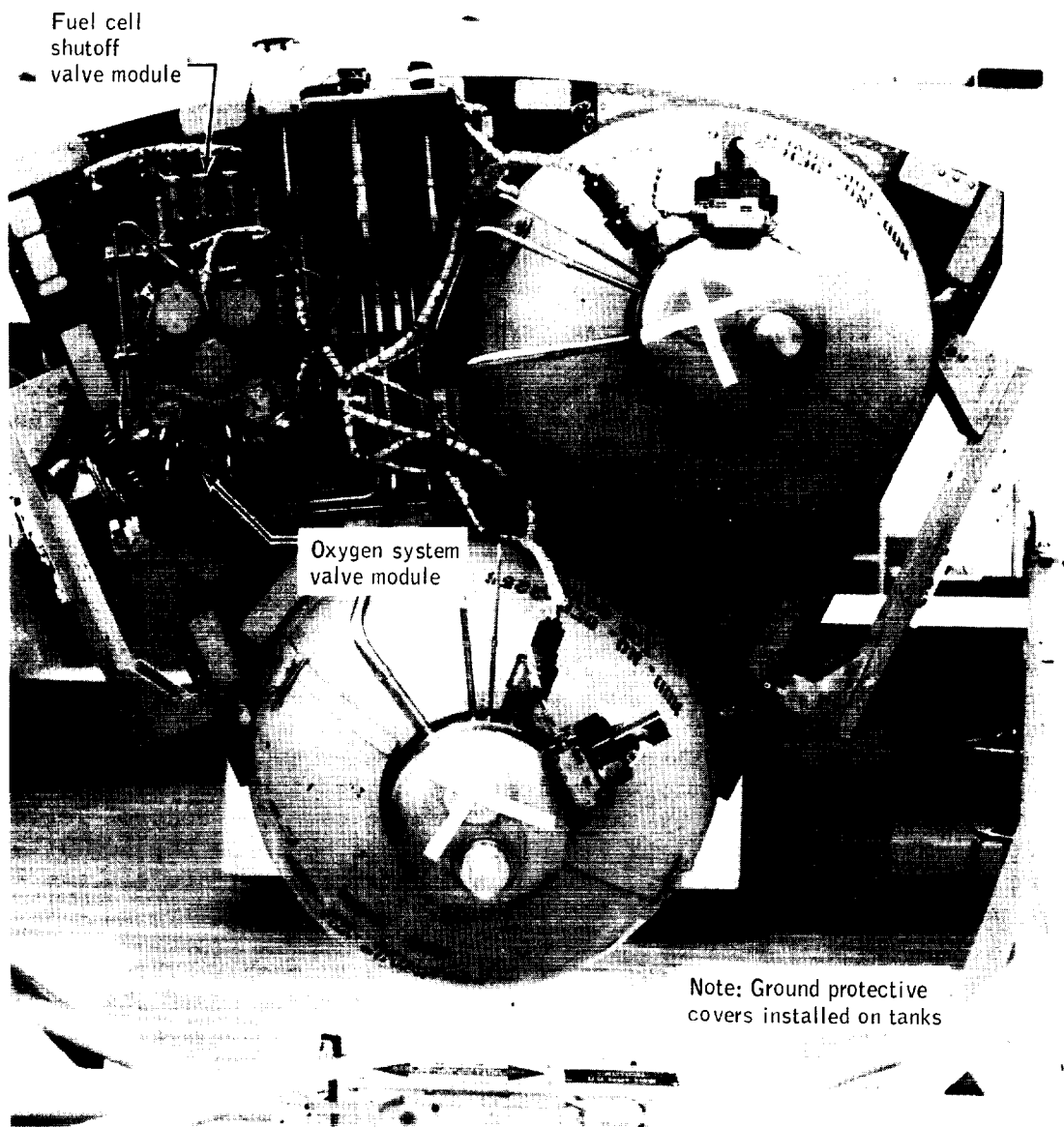

Figure D3-4.- Plan view of the top of the oxygen shelf.

3. A temperature sensor, a platinum resistance thermometer encased in an Inconel sheath. It is attached to the outside of the quantity probe. The resistance of the thermometer and consequently the voltage drop across the unit changes with temperature. The signal conditioner which serves as the reference voltage generator and amplifier is located on the oxygen shelf and its input to the resistor is current-limited to a maximum of 1.1 milliamperes. Four wires exit the tank connector and are connected to the signal conditioner. The signal conditioner is powered from ac bus 2 through a circuit breaker as a parallel load with the quantity gage signal conditioner. Additional description is provided in Appendix B.

4. A quantity gage, a capacitor consisting of two concentric aluminum tubes submerged in the oxygen. The dielectric constant of the oxygen, and consequently the measured capacitance, changes in proportion to its density. The signal conditioner, which serves as the reference voltage generator, rectifier, and amplifier, is located on the oxygen shelf. Two wires exit the tank connector and are connected to the signal conditioner. The signal conditioner is powered from ac bus 2 through a circuit breaker as a parallel load with the temperature sensor signal conditioner. Additional description is provided in Appendix B.

5. A vac-ion pump assembly, attached to the dome of the tank, is used only in prelaunch activities to maintain the tank annulus at the required vacuum level. The pump functions by bombarding a titanium cathode with ionized gas molecules and ion pumping results from the gettering action of sputtered titanium particles. The high-voltage power supply of the pump is an integral part of the pump assembly. Leads for the vac-ion pump do not penetrate the pressure vessel and the pump is not normally powered in flight.

ELECTRICAL SYSTEM CONFIGURATION AT TIME OF ACCIDENT

The electrical power system, in general, provides multiple power busses with switching options for selecting an operating configuration. At 55:53:21, the electrical system was configured in accordance with reference 1, as shown in figure D3-5, with fuel cells 1 and 2 connected to main bus A and fuel cell 3 connected to main bus B. Inverter 1 was connected to main bus A and powering ac bus 1. Inverter 2 was connected to main bus B and powering ac bus 2. Inverter 3 was not connected. Battery busses A and B were not connected to main bus A or B. The switches controlling heater operation for both oxygen tanks were in the "automatic" position, controlling heater operation through the pressure control assembly. Pressures in the oxygen tanks were at levels which did not demand operation of the heaters. Temperature and quantity sensors on oxygen tank no. 2 were energized from ac bus 2. The quantity gage

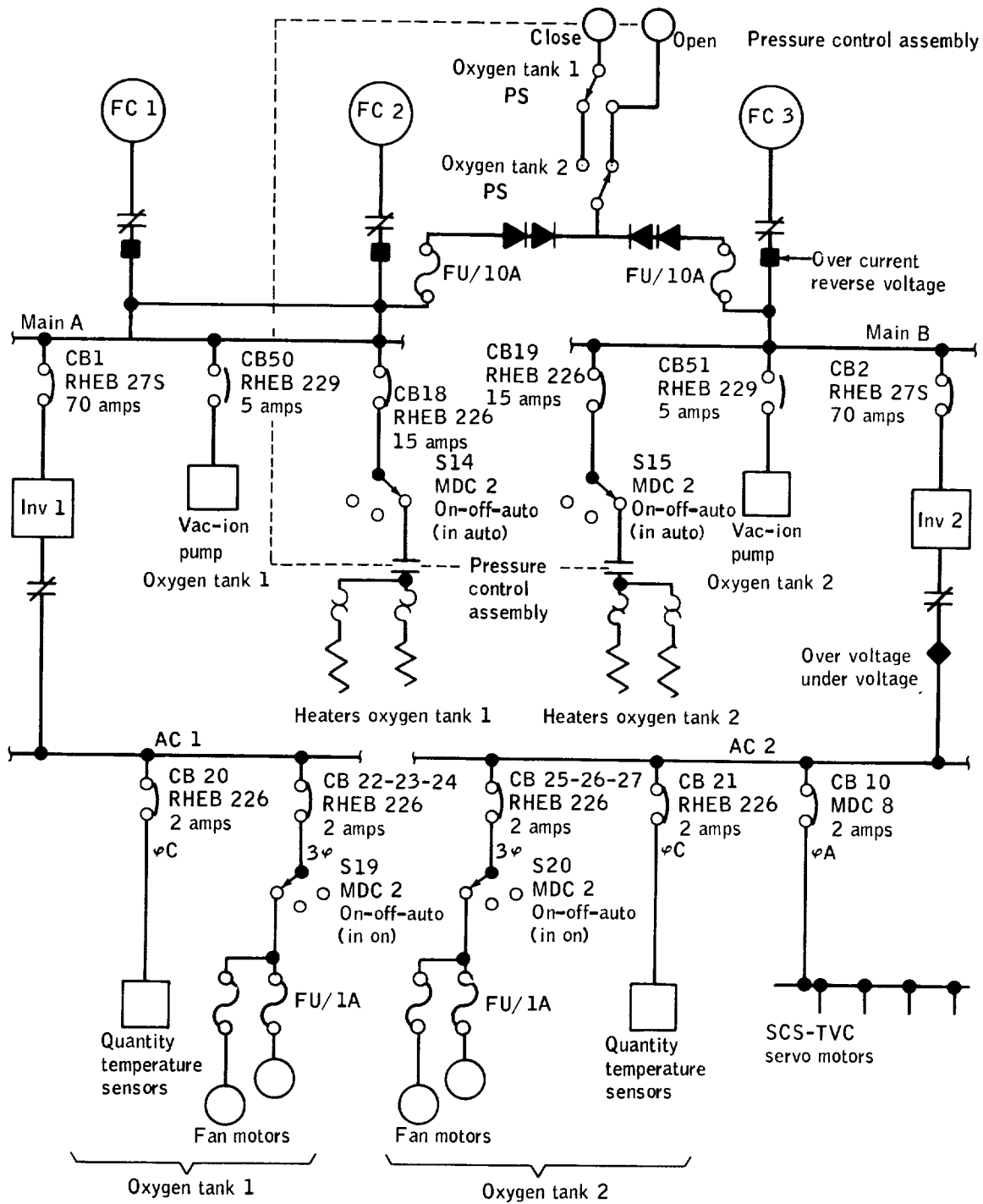

Figure D3-5.- Electrical schematic of relevant portions of electrical power system at 55:53:21.

had remained off-scale high from 46:40:06, indicating a probable short circuit either on the leads or the probe assembly. Operation of the fan motors in the oxygen tanks was accomplished throughout the mission using manual control in lieu of the automatic operation afforded by the logic of the pressure control assembly. A routine operation of the fans was requested by the ground at 55:52:58 and acknowledged by the crew at 55:53:06. Energizing of the fans in oxygen tank no. 1 is confirmed by a drop in voltage of ac bus 1 and an increase in total fuel cell current at 55:53:18. Energizing of the fans in oxygen tank no. 2 is confirmed by a drop in voltage of ac bus 2 and an increase in total fuel cell current at 55:53:20. Data substantiating operation and operation times are presented in Appendix B.

STRUCTURAL EVALUATION OF THE OXYGEN TANK

The oxygen tank consists of two concentric shells, an inner shell (the pressure vessel) and an outer shell (fig. D3-6). The space between the two shells is evacuated during normal operation and contains the thermal insulation system, fluid lines, and the conduit which houses all of the electrical wires entering the pressure vessel.

The oxygen tank is discussed from the standpoint of materials, processing, welding, qualification program, stress levels, fracture analysis, and environmental testing.

Materials, Processing, and Welding

Inner shell.- The pressure vessel is made from Inconel 718, a precipitation hardenable nickel base alloy having good strength, ductility, and corrosion resistance over the range of temperatures from -300° F to above 1400° F. The nominal composition of Inconel 718 is 19 percent chromium, 17 percent iron, 0.8 percent titanium, 5 percent columbium, 0.6 percent aluminum, and the remainder nickel. The heat treatment specified for Inconel 718 for this application was the following:

Hold at 1800° F \pm 25° F for 1 hour

Air cool to 1325 \pm 25° F and hold for 8 hours

Furnace cool to 1150° F and hold for 8 hours

Air cool

This treatment should produce typical ultimate tensile strength of 198,000 psi and yield strength of 170,000 psi at 70° F. Ultimate and

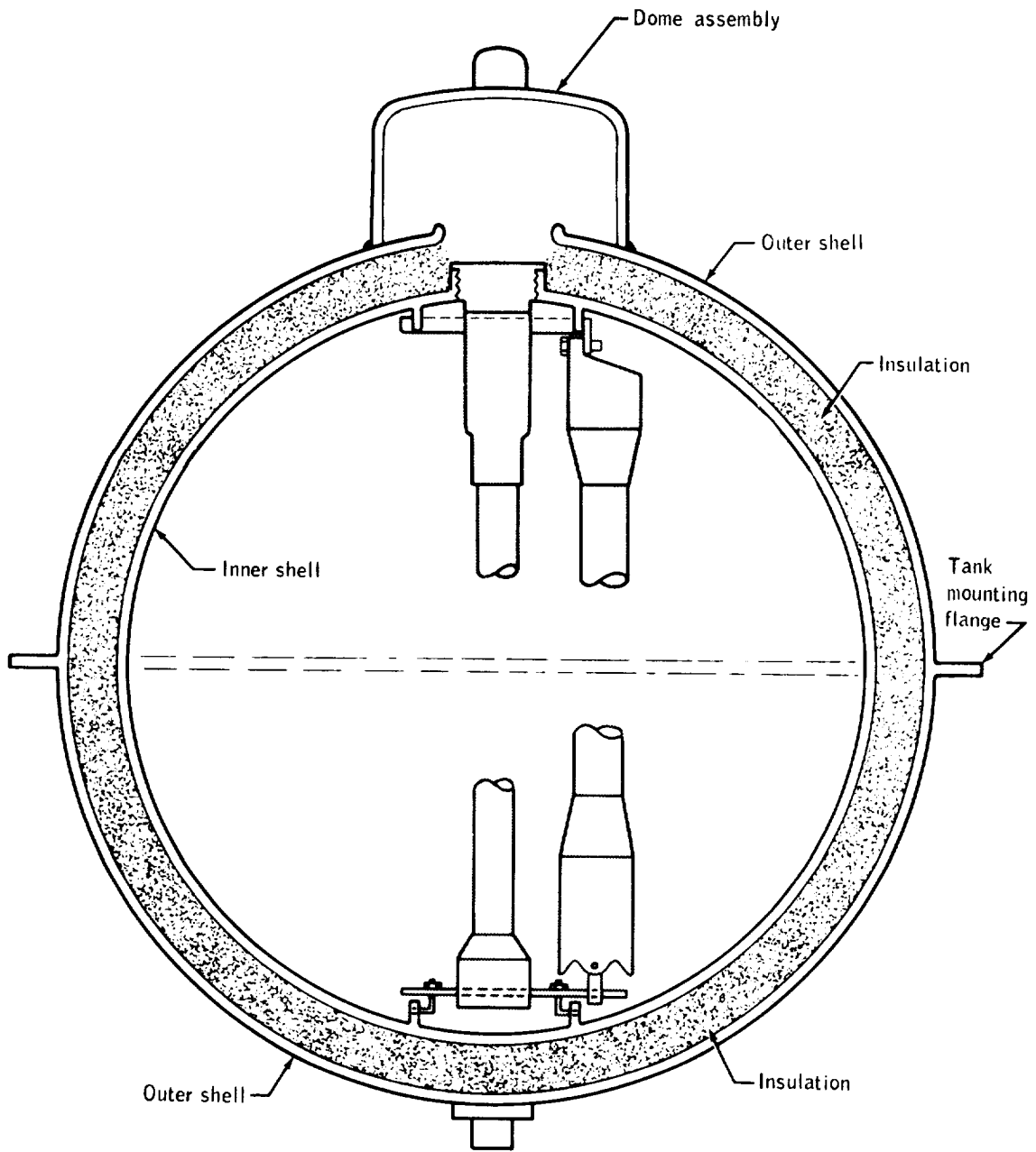

Figure D3-6.- Oxygen pressure vessel schematic.

yield-strength values increase with decreasing temperature and reach 228,000 psi and 189,000 psi, respectively, at -190° F. These values exceed those assumed in the design of the vessel, which were 180,000 psi ultimate tensile strength and 150,000 psi yield strength at room temperature (ref. 2). After burst tests, tensile specimens were cut from test vessels PV-1 and PV-4, and strength measurements were made at room temperature. Each specimen exceeded minimum requirements.

Inconel 718 is considered to be an excellent selection for use at the temperatures required by this design and when properly cleaned is compatible with liquid oxygen.

The pressure vessel is made by electron beam welding two hemispheres at a weld land (fig. D3-7) that is 0.139 ± 0.002 inch thick. The weld land is faired to a membrane of 0.059-inch thickness over a distance of about 2 inches. Cameron Iron Works, Inc., forges the hemispheres to a wall thickness of 0.75 inch, and applies the complete heat treatment. The hemispheres are X-rayed following forging. The Airite Company machines the hemispheres to dimension and welds them together from the outside. First, an intermittent tack weld pass is made, followed by a complete tack weld. The third pass provides complete penetration, and a fourth pass penetrates about one-third of the thickness. Finally, a cover pass is made. Figure D3-8 illustrates the welding sequence. The weldments are X-rayed and dye-penetrant inspected from the outside. Inspection of the inside of the pressure vessel is by visual means only and dye penetrant is not used. Use of one of the available liquid-oxygen-compatible dye penetrants would enhance the detection of cracks or similar weld defects inside the vessel.

The literature has very little data on electron-beam welding of Inconel 718. However, it is frequently used in the aerospace industry and there is no reason to question the practice in this instance. One potential problem sometimes found when this nickel-base alloy is welded is micro-fissuring in the heat-affected zone. Such fissures either do not propagate to the surface, or are very difficult to detect. Unfortunately, high-contrast X-rays of this material are difficult to obtain, particularly in the configuration of this tank. No evidence of a weld cracking problem has been found in the manufacture of these pressure vessels. Thus there is no justification for postulating that micro-fissuring was a factor in the accident being investigated.

A total of 39 data packages on oxygen pressure vessels were reviewed and it was ascertained that only 12 vessels had had weld discrepancies. Table D3-1 describes the weld discrepancies and their disposition. Neither of the two Apollo 13 oxygen tanks flown (S/N 10024XTA0008 and S/N 10024XTA0009) appear on this list. There were no recorded weld discrepancies during the manufacture of these tanks.

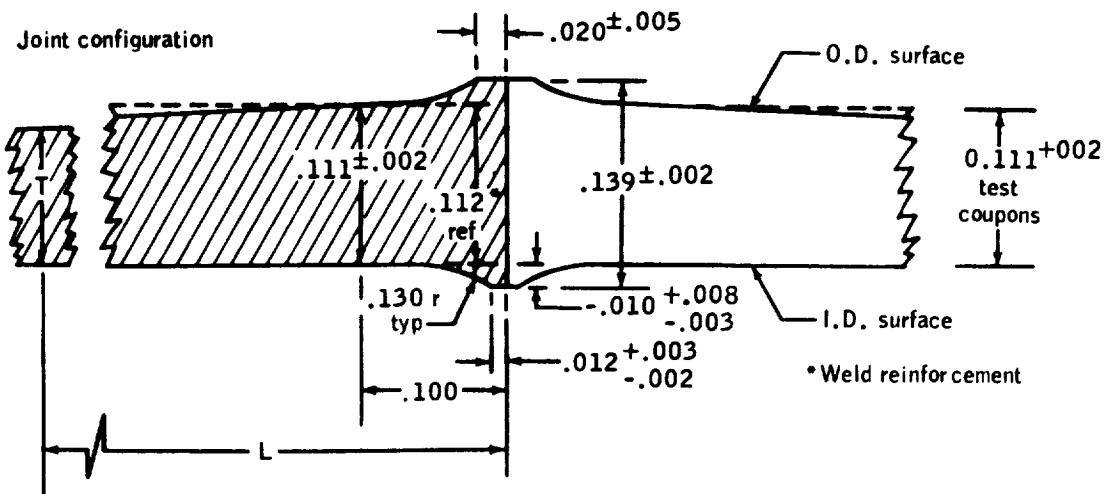

P/M thickness	Tank radius		Dimensions		
	L	T	O.D.	I.D.	
1.000	.084 ±.002	14.808 ref _{arc}	12.528 ⁺⁰⁰⁵ ₋₀	Sph rad	
2.000	.067 ±.002	14.808 ref _{arc}	12.528 ⁺⁰⁰⁵ ₋₀	Sph rad	
3.000	.059 ⁺⁰⁰⁴ ₋₀₀₀	12.587 ref _{arc}	12.528 ⁺⁰⁰⁵ ₋₀	Sph rad	

Weld schedule (Electron beam weld)

Parameter	Pass sequence				
	1-tack	2-seal	3-pene.1	4-pene.2	5-cover
Voltage - Kv	80	80	115	95	85
Amperes - MA	1.5	1.5	6.0	4.0	3.0
Beam deflection - in.	0.012	0.012	.024/.036	.040/.080	0.110
Travel - in./min	18	→	→	→	→
Vacuum - mm hg	2×10 ⁻⁴	→	→	→	→

- Notes: (1) 0.002" gap, 0.003" offset (max typ)
 (2) No weld repairs allowed
 (3) Typical weld sequence shown on attached sketch

Figure D3-7.- Girth weld joint configuration and schedule.

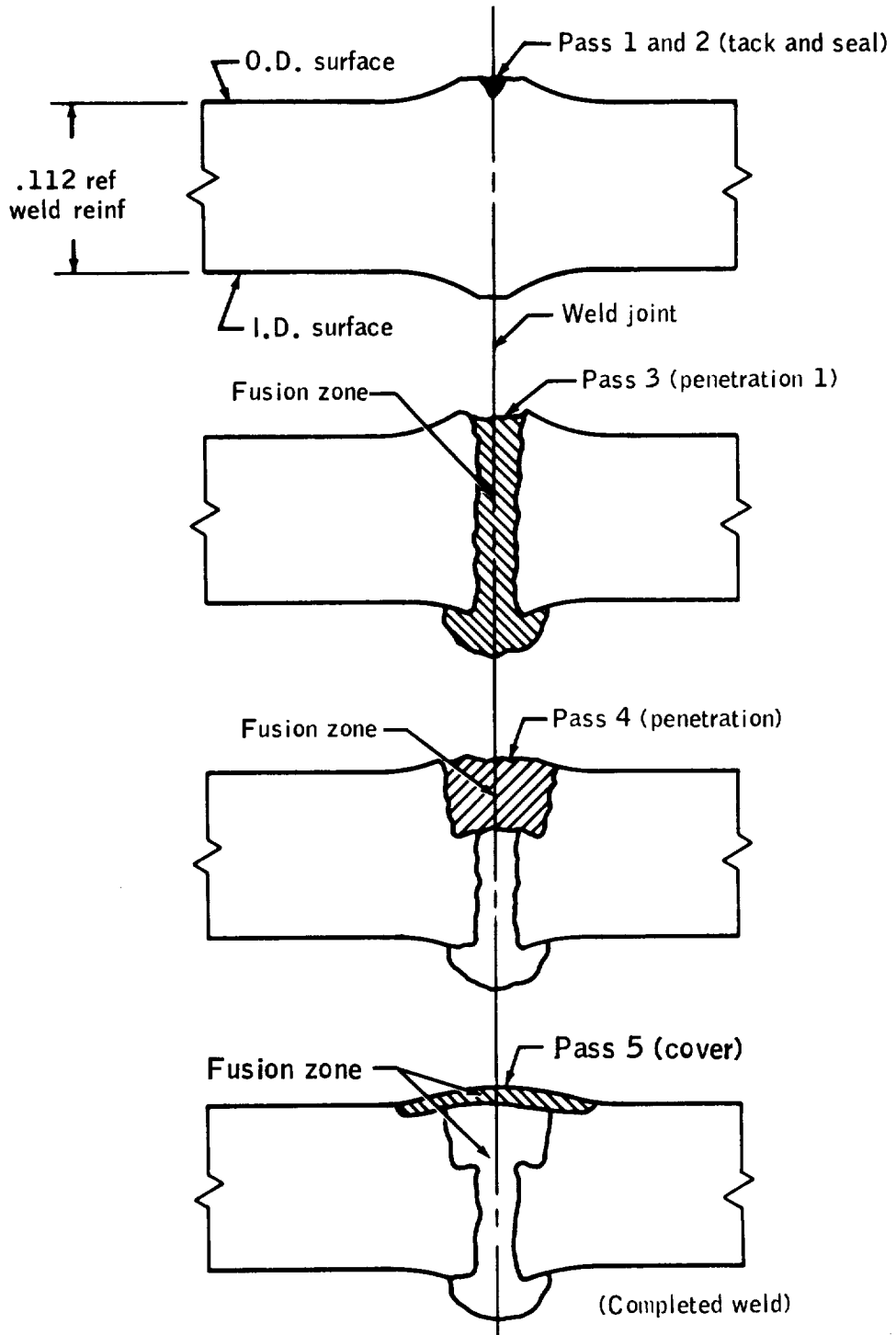

Figure D3-8.- Weld sequence.

TABLE D3-I.- AIRITE PRESSURE VESSEL WELD DISCREPANCIES

Serial no.	Spacecraft	Discrepancy
XTA0005	101	Weld bead 0.005 inch concave by 0.600-inch length. Remainder undercut 0.002 inch below weld land parent metal. Accepted based upon X-ray and comparison to qual. unit used in burst. Beech MRR.
XTA0010	103	Undercut below weld land in one area 0.0015 inch deep by 0.750 inch length adjacent to upper hemisphere. Due to heavy weld drop-through. Accepted for unrestricted use by NR MRD.
XTA0013	106	Hemisphere dimensional characteristics resulted in excessive weld mismatch. Units were successfully welded after NR MRD. Finished vessel met all requirements.
XTA0016	107	<p>Four areas of concavity in center of weld bead: no. 1, 0.0025 inch depth; no. 2, 0.0055 inch depth; no. 3, 0.0045 inch depth; no. 4, 0.0025 inch depth. Concavity due to excessive drop-through. Rewelded using two 360-degree weld passes in accordance with NR MRD.</p> <p>After rework of above, three areas of concavity remained: no. 1, 0.0025 inch below parent metal; no. 2, 0.004 inch below parent metal; no. 3, 0.0015 inch below parent metal. Warpage occurred due to lack of constraint. Accepted for unrestricted usage per NR MRD based upon positive margins of safety.</p>
XTA0022	110	Borescope showed entire weld land visible and not consumed through 360-degree circumference due to lack of penetration. Rewelded per NR MRD instructions.
XTA0017	110	<p>Borescope revealed lack of drop-through in an area 1/2 inch in length. Rewelded by one 360-degree pass per NR MRD.</p> <p>Edge of weld on upper hemisphere undercut from 0.001 inch to 0.003 inch into parent material for 360 degrees following rewelding per above--reworked and accepted by NR MRD based upon stress analysis.</p>

TABLE D3-I.- AIRITE PRESSURE VESSEL WELD DISCREPANCIES - Concluded

Serial no.	Spacecraft	Discrepancy
XTA0024	111	Hemisphere dimensional characteristics out of specification. Units successfully welded after certification test specimens duplicating conditions were acceptable. Discrepancies were consumed during welding. Beech MRR.
XTA0021	111	Incomplete weld penetration for a distance of 17-3/8 inches. Rewelded per NR MRD.
XTA0033	Unassigned	Upper hemisphere dimensions out of specification. Accepted for welding with fit up with another hemisphere. Beech MRR.
XTA0019	Unassigned	Borescope revealed complete weld land (0.012 inch) still visible--repair welded per NR MRD.
XTA0003	Unassigned	Borescope and X-ray revealed incomplete penetration major distance of weld. Rewelded per Airite procedure. Beech MRR. Weld concavity from 0.001 to 0.0055 inch deep on drop-through side of weld on upper hemisphere. Maximum width is 0.003 inch--accepted for unrestricted use by NR MRD.
XTA0032	Unassigned	Borescope revealed area approximately 0.600 inch long with incomplete consumption of weld lands. X-ray indicated complete penetration. Rewelded by Airite procedure. Beech MRR.

Outer shell.- The outer shell is made of Inconel 750, also a nickel base alloy having the following nominal composition: 15 percent chromium, 7 percent iron, 2.5 percent titanium, 1 percent columbium, 0.7 percent aluminum, and the remainder nickel. According to references 3 and 4, the outer shell can be annealed. Typical strength values for the annealed alloy are 130,000 psi ultimate strength and 60,000 psi yield strength. This is more than adequate for this application. The wall thickness of the outer shell is 0.020 ± 0.002 inch. When the space between the two shells is evacuated, the outer shell preloads the insulation between the two shells. The dome of the outer shell contains a burst disc designed to vent the space between the shells to ambient pressure at a pressure differential of 75 ± 7.5 psi.

Cryogenic tank tubing.- Three fluid lines (fill line, vent line, and feed line), and an electrical conduit are fusion welded to the close-out cap (tube adapter) that is screwed into the top of the pressure vessel. The cap is secured to the pressure vessel by a circumferential seal weld. The four lines are made of Inconel 750, annealed Aerospace Materials Specification (AMS) 5582. The tubes traverse the space between the two shells and exit the outer shell at the side of the tank coil cover. The nominal strength of the annealed tubing is 140,000 psi ultimate, and 80,000 psi yields, which is more than adequate for the application, as the stress level in the tubing is only about 17,000 psi.

After the tubes are welded to the cap, a visual inspection, helium leak test (3 psi), and proof-pressure tests are used to assess the quality of these welds (ref. 5). This is reasonable because of the low stress levels involved. Liquid-oxygen-compatible dye penetrant inspection and subsequent cleaning would enhance the possibility of finding surface cracks. X-rays of these welds would be difficult to obtain and should be of dubious value.

The four lines extend only a few inches from the tank dome. When the tank is assembled on the oxygen subsystem shelf, the fluid tubes are joined by brazing to the 304L annealed corrosion resistant steel tubes of the spacecraft systems. Although joining Inconel 750 and 304L steel constitutes a bimetallic couple, it is satisfactory in this application because of the dry environment that is maintained.

Qualification Program

The pressure vessel qualification program was conducted by Beech Aircraft Corporation. Four pressure vessels were subjected to burst tests as described in references 6 through 12.

Prior to each burst test, the vessel was subjected to an acceptance pressure test at 1357 psig and checks were made for leaks. No leaks were

observed in any of the vessels. In Appendix F of reference 9, there is an analysis of the proof test of vessel PV-4. The following table lists some of the strain gage readings taken during the qualification testing.

MEASURED STRESS LEVELS IN KSI

Tank	Internal pressure, psig	2.8 inches from upper pole	2.0 inches from girth weld	Lower pole area	Membrane (0.061-inch thick)
Tank PV-4 70° F	1020 1357	108.3 ^a 139.7 ^b	106.1 139.4	97.7 128.9	105.8 -
Tank PV-1 -320° F	1020	116.7	113	-	-

^aDesign value 110 ksi

^bDesign value 145 ksi

For the cryogenic burst tests, the vessels were filled with liquid nitrogen and placed in an open dewar of liquid nitrogen. The ambient temperature burst tests used water as the pressuring medium. The burst pressures of the qualification vessels were as follows:

<u>Tank</u>	<u>Test condition</u>	<u>Burst pressure, psig</u>
PV-1	Cryogenic (LN ₂ , -320° F)	2233
PV-2	Cryogenic (LN ₂ , -320° F)	2235
PV-3	Ambient temperature (70° F)	1873
PV-4	Ambient temperature (70° F)	1922

All ruptures were similar; the failures apparently started about 2 or 3 inches from the pole of the tank on the top at the transition from the heavier section to the membrane section. The fractures progressed around the boss area, proceeded essentially perpendicular to the girth weld, and then crossed the girth weld in both ambient tests and in one of the cryogenic tests. In the other cryogenic temperature test vessel, a large fragment came out of the upper hemisphere. In no case was there violent fragmentation. After the burst of PV-1 at 2233 psig, initial failure was judged to have occurred at the end of the neck taper around the top pole. The rupture progressed downward, branching into a Y. After coming into contact with the weld, the rupture followed the weld fusion zone.

The following is a quotation from reference 9:

"2.3.7 Conclusions - Based on the above analysis and evaluation, the following conclusions are made:

- (1) Burst failure initiated at the end of the boss taper in the upper hemisphere and resulted from plastic deformation beyond the tensile strength of the base material at ambient temperature.
- (2) Rupture was of a hydrostatic type.
- (3) The appearance of all failed areas was judged to indicate good ductility of the base metal and weldments.
- (4) No significant mismatch was observed on the specimens investigated.
- (5) All fractures across the weld were shear fractures and of a secondary nature.
- (6) The grain size throughout the vessel was fine (ASTM-5 to 8) and relatively equiaxed.
- (7) The ambient burst test was judged to be completely successful by Beech Aircraft Corporation Engineering, and the results of the test indicate approximately 100 percent efficiency for the material at the test temperature."

The data from these pressure vessel tests satisfy the qualification requirement for an ultimate factor of safety of 1.5 at ambient temperature with adequate margins.

In 1967 North American Rockwell verified analytically the structural integrity of the oxygen tank (ref. 13). An MSC structural analysis report (ref. 14), also issued in 1967, confirmed the structural integrity of these tanks and compared the analysis with the results of the burst tests. This comparison showed good correlation between analytical and test results. The MSC calculations were based on minimum guaranteed sheet thicknesses and minimum material properties. Even better correlation is obtained by using the actual thicknesses and material properties of the test items.

These analyses show the maximum stresses in the tank during pressurization to be in the upper spherical shell at the transition from the constant thickness shell to the thickened area adjacent to the penetration port. Actual stresses determined from strain gage readings during burst tests are consistent with the analyses.

FRACTURE MECHANICS

The design of the supercritical oxygen tank was based on conventional elastic stress analysis which assumes a homogenous material and uses the conventional tensile properties for the calculation of safety factors. In reality, all fabricated materials contain crack-like flaws which may be associated with weld defects or with metallurgical segregations which can transmit only negligible loads across their boundaries. The load-carrying capacity of high-strength materials, particularly in thick sections, may be severely reduced by the presence of even small flaws which can trigger a brittle catastrophic failure at loads well below those considered safe by conventional design procedures. Furthermore, in many cases the type of flaw present cannot be found by non-destructive inspection techniques and, for this reason, a proof test must be depended upon to identify those structures which might fail in service.

At the outset it should be appreciated that linear elastic fracture mechanics and the associated American Society of Testing Materials (ASTM) Standard Method of Test for Plane Strain Fracture Toughness, K_{Ic} , are not directly applicable to an analysis of the fracture of the oxygen pressure vessel material in the thicknesses employed, or for that matter in very much larger thicknesses. The evidence for this lies in early results from a fracture test program now underway at Boeing. These results indicate that specimens containing deep cracks in parent metal, or in electron beam weld metal representative of the oxygen pressure vessel, fail at net stresses very close to or slightly above the corresponding yield strength whether they are tested at 70° F or -190° F. While the plane strain fracture toughness, K_{Ic} , cannot be determined from the data available, a lower bound estimate may be made from test results reported on 2-3/4 inch diameter notched round bar specimens (ref. 15). These large specimens were cut from forgings of Inconel 718 and tested at -110° F. The corresponding yield strength was about 172 ksi and the notch strength was 40 percent above the yield strength. Formal calculations give an "apparent K_{Ic} " value of 190 ksi $\sqrt{\text{in}}$. which may be taken as a lower bound for a yield strength of 172 ksi. This is approximately equal to the 70° F parent metal yield strength of the oxygen pressure vessel. Properly made electron beam weldments should have at least this

high a K_{Ic} value since they are not heat treated after welding and therefore have a lower yield strength than the parent metal. At -190° F the yield strength of the parent and weld metal will increase about 10 percent; however, for this austenitic alloy the corresponding change in toughness would be expected to be negligible.

Failure Modes

While "apparent K_{Ic} " values should not be used to develop relations between tank wall stress and critical flaw size, the lower bound value of K_{Ic} can be used to show that the pressure vessel would not fail in a brittle manner. When the parameter β_{Ic} , the ratio of crack tip plastic zone size factor to specimen thickness, is greater than 1-1/2, brittle fracture is very unlikely. This parameter is given by

$$\beta_{Ic} = \frac{1}{B} \frac{K_{Ic}^2}{F_{ty}}$$

For the oxygen tank B the effective weld land thickness after welding is 0.111 inch; the yield strength of the weld F_{ty} is 110 ksi at -190° F (table D3-II), and the lower bound of K_{Ic} is 190 ksi $\cdot \sqrt{\text{in.}}$.

TABLE D3-II.- TYPICAL PARENT METAL AND WELD TENSILE PROPERTIES^a

Temperature, ° F	Parent metal		Weld metal	
	F_{tu} - ksi	F_{ty} - ksi	F_{tu} - ksi	F_{ty} - ksi
-190	228	189	187	^b 110
70	198	170	158	100

^aDetermined by Boeing on Inconel 718 forgings using same heat treatment given the oxygen pressure vessel and on electron beam weldments given no heat treatment.

^bGage length equal to weld width.

Using these values, $\beta_{Ic} = 27$. A similar calculation for the parent metal in the membrane yields $\beta_{Ic} = 16$. On this basis, the mode of failure of the pressure vessel would be expected to be ductile tearing rather than shattering. However, it is not known whether this mode would lead to a stable through-thickness crack, and a consequent slow leak into the space between the pressure vessel and the outer shell, or to a rapid tearing fracture with consequent destruction of the outer shell and the quick release of a large volume of oxygen. Which of these two possibilities is most likely depends in part on the flaw size giving rise to the final fracture and on the rate of depressurization as compared with the rate of crack propagation. To settle this matter would require burst tests on intentionally flawed tanks.

If a local area of the pressure vessel wall or the tube adapter were heated to a sufficiently high temperature by some internal or external source, the tank would blow out at this local area. According to data furnished by Boeing under contract to NASA, the strength of Inconel 718 would degrade rapidly if the metal temperature exceeded about 1200° F. At 1400° F the tensile strength would be about 50 percent of the room temperature value, and at 1600° F would be less than 30 percent of this value. At a tank pressure of 1008 psi, the parent metal wall stress based on membrane theory is about 108 ksi. A ductile rupture at this stress would likely occur if the tank were at a uniform temperature of 1400° F. The restraining effect of the cool surrounding metal would raise the temperature required for a local blowout and this situation is best evaluated by suitable experiments.

Effectiveness of the Proof Test

The proof test is the last, and should be the best, flaw detection procedure applied to a pressure vessel. Ideally, the proof test should cause failure if there are any flaws present that could grow to a critical size during subsequent pressurization. For the oxygen tanks in question, a fracture mechanics analysis cannot be made to assess the adequacy of the proof test because of the high toughness of the material and the thin sections used. These factors in themselves, of course, contribute to the confidence that can be placed in the integrity of the pressure vessel and, as discussed in the previous section, essentially rule out the possibility of brittle failure. However, it is worthwhile to estimate the effectiveness of the proof test in identifying those pressure vessels which might develop leaks during pressure cycles subsequent to proof. The failure model proposed considers the plastic instability fracture of a ligament of material produced by incomplete fusion during electron beam welding. The main features of this model are illustrated in figure D3-9. It essentially represents a long flaw in the tank wall at the

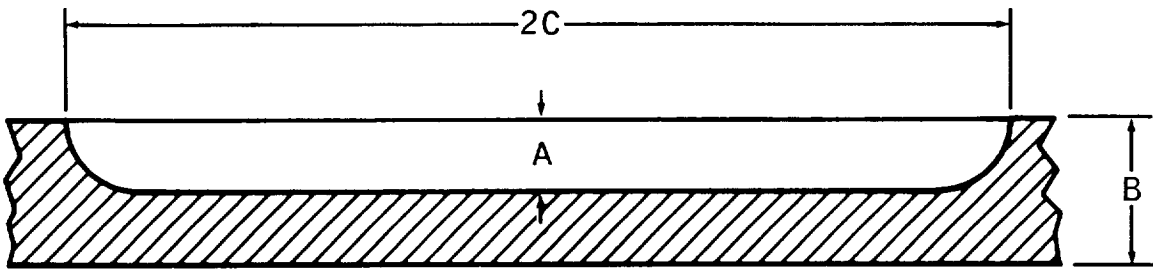

Area of lack of fusion produces
an effective crack of depth A
& length 2C in tank wall of
thickness B. $2C \gg A$

Figure D3-9.- Ligament model for ductile fracture of pressure vessel.

equatorial weld. It is postulated that the ligament will fail when its stress reaches the tensile strength of the material. Calculations show that the ligament stress σ_l is related to the average wall stress

σ_g as follows:

$$\sigma_l = \sigma_g \frac{B}{B - A}$$

where the dimensions are defined in figure D3-9. The maximum relative flaw depth that can be sustained without failure is then

$$\frac{A}{B} = 1 - \frac{\sigma_g}{F_{tu}} \quad (1)$$

where F_{tu} is the ultimate tensile strength. Failure will occur by tearing of the ligament accompanied by rapid decompression of the tank. It should be appreciated that this is a rather crude model of ductile fracture, and will probably overestimate the failure stresses in a spherical vessel. However, it should be useful in assessing the effectiveness of the proof tests in light of subsequent service, because of the very large margins between proof and operating pressures.

The pressure cycles applied to the Apollo 13 oxygen tank no. 2 are shown in table D3-III. It should be noted that the oxygen tank no. 2 had several extra pressure cycles in addition to those normally applied. These were associated with rechecks for heat leaks and with the "shelf drop" incident. The additional cycles do not affect this analysis nor should they have reduced the integrity of the tank during mission service.

The ratio of tank pressures necessary to cause ligament failure for a given relative flaw size A/B at two temperatures will be equal to the ratio of the tensile strength of the material at these temperatures. On this basis, the maximum flaw size that could exist before CDDT is established by the last high pressure helium proof specified as 1260 $\begin{smallmatrix} +50 \\ -0 \end{smallmatrix}$ psi at ambient temperature (1276 psi for oxygen tank no. 2). From equation (1), the corresponding value of A/B for the weld metal is 0.55, based on a weld tensile strength of 158 ksi at room temperature, a weld land thickness of about 0.111 inch, and a nominal weld land stress of 71 ksi.

The question now arises as to whether a flaw of this size could propagate through the wall during subsequent pressurization and produce a leak. Flaw growth could occur by sustained loads or cyclic loads. In the absence of an aggressive environment, it is generally recognized that sustained load flaw growth will not occur at loads less than 90 percent of that necessary to produce failure in a continuously rising

TABLE D3-III.- HISTORY OF PRESSURE CYCLES APPLIED TO APOLLO 13
 SUPERCRITICAL OXYGEN TANK NO. 2

[Record from North American Rockwell Space Division]

Organization	Test media	Date	Peak pressure, psi (a), (b)	Time, hr:min	Test name
Beech	H ₂ O + He	6-20-66	1336	00:24	Pressure vessel, acceptance
Beech	GN ₂	7-15-66	1340	00:56	Internal leak check on complete assembly
Beech	LN ₂	7-15-66	920	00:51	Cold shock
Beech	GN ₂	9-15-66	^c 1333	00:54	Internal leak check
Beech	LN ₂	9-15-66	^c 918	00:51	Cold shock
Beech	Helium	10-19-66	1303	09:49	Proof and leak
Beech	Helium	10-19-66	888	01:00	Proof and leak
Beech	LOX	12-20-66	1333	40:05	dq/dm
Beech	LOX	10-24-66	922	25:04	dq/dm
Beech	Helium	1-31-67	^c 1305	09:07	Proof and leak
Beech	LOX	2- 2-67	^c 1321	28:39	dq/dm
Beech	LOX	2- 3-67	^c 920	22:16	dq/dm
NAR-SD	Helium	4-29-68	1262	06:45	Leak
NAR-SD	Helium	5- 1-68	1002	01:00	Leak
NAR-SD	Helium	5- 1-68	968	13:13	Leak
NAR-SD	Helium	5- 2-68	1104	08:02	Leak
NAR-SD	Helium	5-27-68	^{c,d} 1262	02:54	Leak
NAR-SD	Helium	5-28-68	^c 1102	01:07	Leak
NAR-SD	Helium	11-18-68	^d 1276	02:24	Leak
NAR-SD	Helium	11-18-68	1002	01:40	Leak
NAR-SD	Helium	7-17-69	1025	01:39	Leak
NAR-SD	LOX	4- 9-70	925	43:53	Launch loading

^a Pressure cycles below 400 psi not recorded

^b It could not be determined whether pressure measurements represented psia or psig

^c Pressure cycles not normally applied

^d 1260 ⁺⁵⁰
 - 0 psi specification

load test. Following the 1276 psi helium proof test, no subsequent pressurization exceeds 85 percent of this pressure, and consequently sustained load flaw growth is extremely unlikely. Confidence in this conclusion can be obtained from the test results of a Boeing program now underway. These results apply to specimens containing small but deep cracks in both parent metal and electron beam weld metal of Inconel 718 forgings heat treated in the same way as the oxygen tank material. The early data show no crack growth in 20 hours at -190° F for specimens subjected to 160 percent of the nominal operating stress.

Cyclic loads during the flight operation would be caused by cyclic operation of the heaters (about once per one-half hour). The associated pressure cycles are very small with a minimum-to-maximum stress ratio of about 0.93. Flaw growth due to these small cyclic loads is considered extremely unlikely during the mission for the following reason: maximum nominal operating stress in the weld land (at 935 psi) is about 28 percent of the weld tensile strength at -190° F. Therefore, with a flaw size of $A/B = 0.55$, the ligament stress would be only about 63 percent of the weld tensile strength. On the basis of the known fatigue behavior of Inconel 718 welds (ref. 16), it would be expected that ligament failure due to cyclic loads induced by heater operation would not be a consideration until hundreds of cycles had been accumulated. Confidence in this conclusion can be obtained from the early results of the previously mentioned on-going Boeing program. These results indicate that parent and electron beam weld metal specimens of Inconel 718 containing small but deep cracks do not show crack growth at -190° F after 15,000 cycles at minimum-to-maximum stress ratio of 0.95 and a mean stress of about 170 percent of the nominal operating value.

While the conclusions based on the ligament model are consistent with the Boeing data obtained from specimens with small flaws, these test results cannot be used to prove the validity of the model because it applies to large flaws. Therefore, it is planned to check the conclusions reached on the basis of this model by testing specimens at MSC which will contain large, deep cracks. Specimens of both electron beam welds and parent metal will be subjected at -190° F to the mean and cyclic stresses encountered in flight operation of the oxygen tank.

In assessing the effectiveness of the proof test, no consideration was given to the possibility of failure in regions remote from the welds (e.g., the main membrane or neck of the vessel). Conventional stress analysis (ref. 14) shows that the highest stresses occur in the transition region between the weld lands and the uniform thickness membrane. Stresses in the neck region are very low and comparable to those in the weld land. The ligament model is not applicable to these regions of the vessel remote from the weld since there is no clear mechanism by which a large flaw could be introduced into the parent metal. Experience shows that

crack-like imperfections are sometimes introduced by the forging process, but these are relatively small and confined to the surface layers of the forging. Such defects are easy to detect and are usually removed by the machining process. It is the standard practice of the aerospace industry to reject forgings that have cracks that cannot be removed by machining. With this in mind, there is no reason to doubt the effectiveness of the final high-pressure helium proof test insofar as the pressure vessel main membrane area is concerned.

Possibility of Tank Failure During Apollo 13 Mission

On the basis of the foregoing information, it is extremely unlikely that the oxygen tank no. 2 pressure vessel ruptured at the maximum recorded flight pressure of 1008 psi and temperature of -160° F because of crack propagation. Based on the previously described ligament model, a pressure vessel passing the last high-pressure helium proof test should withstand a pressure load nearly twice that of the maximum flight pressure at -160° F. As described previously, a high-temperature blowout of the pressure vessel is entirely possible, and if this occurred the fluid released could have caused rupture of the dome or of the outer shell.

DYNAMIC TESTING

During the development and qualification of the command and service modules (CSM), a series of dynamic tests was conducted on major vehicle elements as well as subassemblies. The following sections describe those tests applicable to the cryogenic oxygen tank.

Oxygen Tank Assembly Dynamic Testing

Dynamic testing was accomplished during September 1966. Flight-type oxygen tank assembly hardware, selected as a test specimen, successfully completed this testing as documented in reference 17.

Vibration testing.- The test specimen was subjected to vibration in each of three axes, and the vibration level was maintained for 15 minutes in each axis. The specified test levels, representing the combined envelope of the atmospheric and space flight conditions, were as follows:

<u>Frequency, Hz</u>	<u>g^2/Hz</u>
10	0.003
10-90	0.003 to 0.025 at 3 dB/octave
90-250	0.025
250-400	0.025 to 0.015 at 3 dB/octave
400-2000	0.015

The test spectrum is shown as the solid line in figure D3-10. No significant anomalies were recorded during these tests. These tests qualified the oxygen tank assembly for the launch and space flight conditions.

Acceleration testing.- The oxygen tank assembly used in the vibration testing mentioned in the preceding paragraph was also tested for acceleration in each of three axes for at least 5 minutes in each direction. The acceleration was 7g in the launch axis direction and 3g in the other two orthogonal axes. These accelerations are greater than those expected during normal ground handling or during flight. No anomalies were recorded during these tests.

Apollo CSM Acoustic and Vibration Test Program

In addition to the dynamic testing previously described, the oxygen tank and shelf assemblies plus other CSM subsystems were tested as part of the Block II, Spacecraft 105/AV Certification Test Program conducted during February and March 1968 (ref. 18). These tests qualified the Block II CSM hardware against the acoustic and vibration criteria, and confirmed the structural integrity of the CSM for vibration inputs which enveloped the complete ground and flight environmental requirements as specified in reference 19.

Figure D3-11 shows the transducer locations used for both the acoustic and vibration testing. Test instrumentation in the area of the oxygen tank was as follows:

- SA 110 (+X) Oxygen shelf on bracket, 18 inches from beam 4
- SA 111 (-R) Oxygen shelf on bracket, 18 inches from beam 4
- SA 112 (-T) Oxygen shelf on bracket, 18 inches from beam 4
- SA 113 (+X) Oxygen shelf on centerline

Note: R = radial, T = tangential

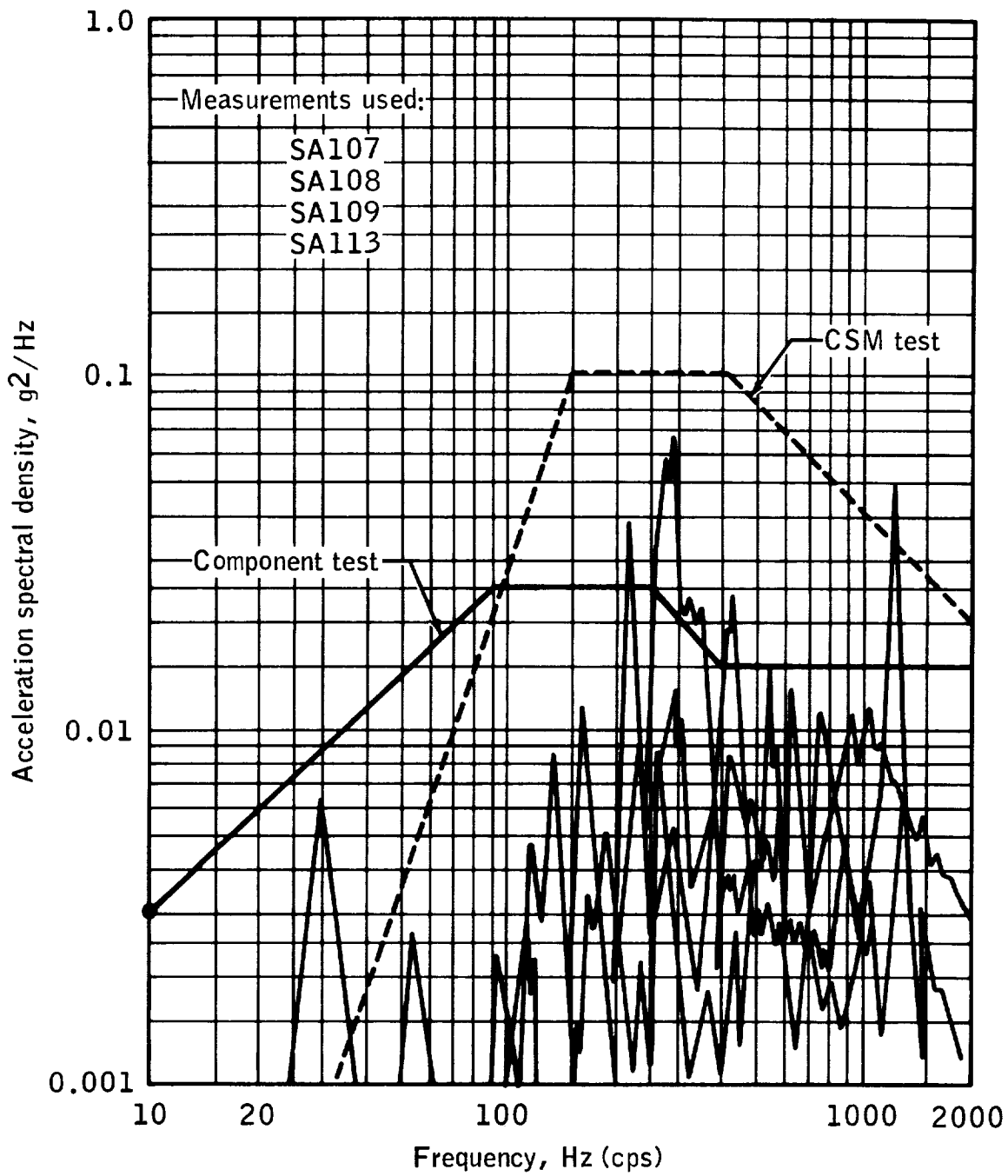

Figure D3-10.- Service module data overlays and specified test spectrum.

Vibration testing consisted of sinusoidal sweeps in the 4- to 30-Hz range, followed by sinusoidal dwells at the prominent resonance frequencies. CSM vibration response was controlled to 0.075-inch double amplitude for the 4- to 8-Hz frequency range and 0.1g peak for the 7- to 30-Hz frequency range.

Acoustic tests were performed to measure the vibratory response in the 20- to 2000-Hz frequency range. The acoustic spectrum of interest for the oxygen tank was adjusted to obtain a test spectrum as shown in figure D3-10.

The vibration and acoustic tests were completed without failures or any pertinent anomalies in the oxygen tank or tank shelf. The maximum observed accelerations during the tests are given in the following table:

Inst. no.	Vibration		Acoustic
	X-axis 4- to 30-Hz sweep, g (rms)	Z-axis 4- to 30-Hz sweep, g (rms)	X-axis 4- to 30-Hz sweep, g (rms)
SA 110	0.02	0.05	0.005
SA 111	.5	.5	.35
SA 112	.5	.6	.6
SA 113	.15	.4	.17

The responses of four transducers (SA 107 through SA 109 and SA 113) are shown in figure D3-10.

The tests confirmed the following:

1. Structural integrity of Block II CSM wiring, plumbing, bracketry, and installed subsystems when subjected to the dynamic loads resulting from spacecraft exposure to the aerodynamic noise environment expected during atmospheric flight.
2. Structural integrity of the Block II CSM when it is experiencing the low vibratory motions produced by atmospheric flight.

Based upon the results, it is concluded that the tests were adequate to qualify the CSM for flight on the Saturn V. Of course, this qualification would not necessarily cover abnormal conditions such as mishandling.

SHOCK TESTING

Although NR specification (ref. 20) requires qualification testing of the oxygen tank assembly inside its shipping container for ground handling and transportation conditions, further investigation revealed that this requirement was deleted on January 8, 1965. This deletion is documented in paragraph 3.8.4.3 of reference 21, which states, "Revised Apollo Test Requirements, no testing of transportation and ground handling environments (shall be required). Packaging is designed to preclude exposure of components to environments beyond transportation levels." The shipping container (ref. 22) was reportedly shock tested during the development program in 1964 and successfully sustained the test environment described in reference 23. From these tests it was concluded that the shock attenuation system in the shipping container was acceptable. There was no requirement for shock testing of the oxygen tank assembly outside its shipping container.

INTERNAL COMPONENTS

There are a number of components internal to the oxygen tank. These are individually discussed in the following sections.

Quantity Gage

The quantity gage capacitor (fig. D3-12) consists of two concentric aluminum tubes which are adequately mounted and supported. The inner tube of the capacitor constitutes the extension of the fill line. The outer tube is perforated to insure access of the oxygen to the space between the capacitor plates. The relative position of the two plates is maintained by insulating Teflon separators. Shorting of the capacitor at the plates within the tank requires bridging of the gap between the tubes by a conductive material. Shorting could also be induced by the contact of bare lead wires resulting from insulation damage. The power input to the quantity gage is regulated and limited by the high impedance source of the signal conditioner. The spark that could be

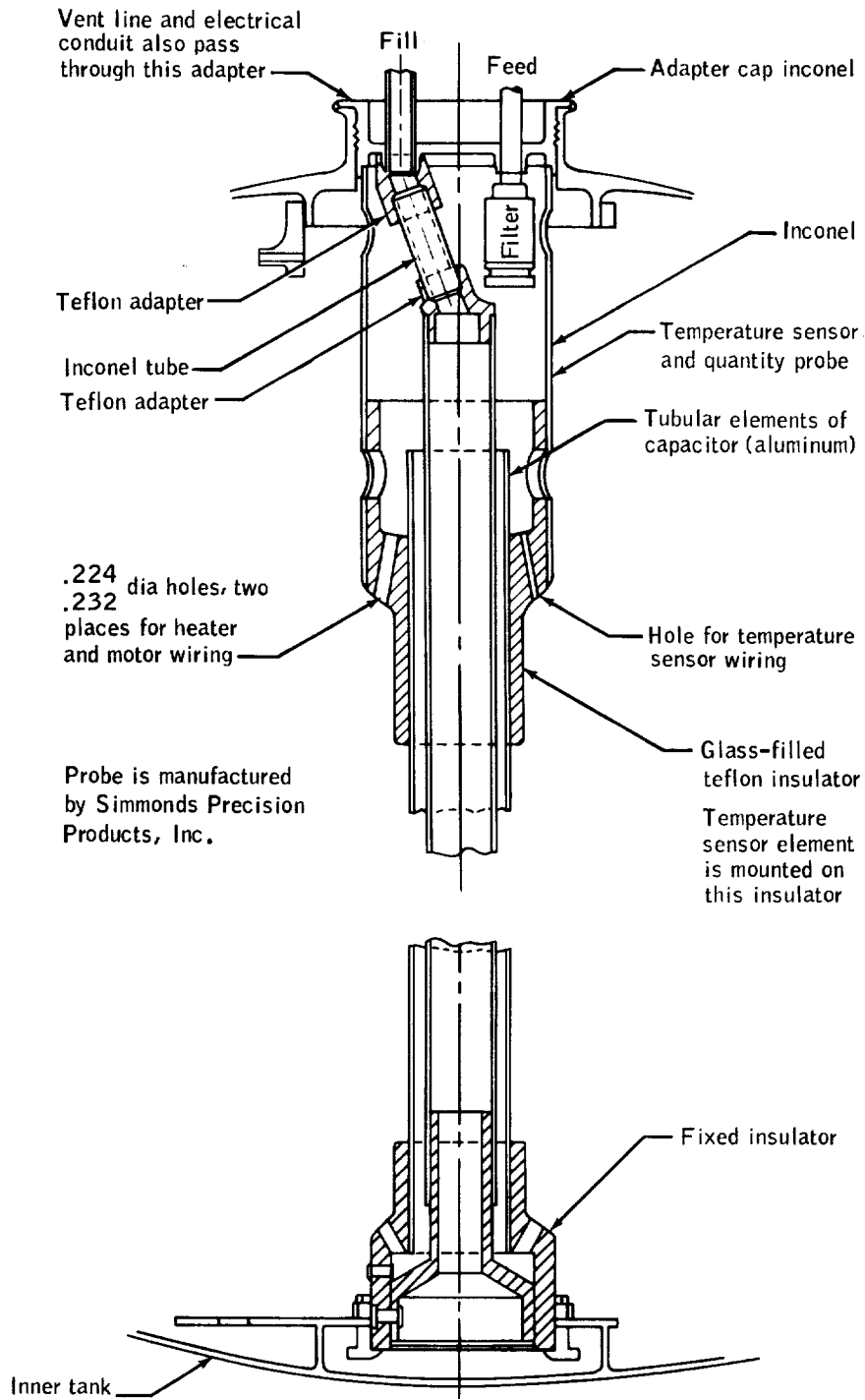

Figure D3-12.- Quantity gage.

generated is at the 7- to 10-millijoule level. The evidence provided by the data can be construed to indicate that the effects of the probe failure during flight were limited to data loss.

Heaters

The two electrical heaters (fig. D3-13) are mounted to the heater fan support tube. The heaters are nichrome resistance wire imbedded in magnesium oxide insulation encased within a sheath of stainless steel. The stainless steel sheath is spiralled and brazed to 12.0 inches of the support tube length. The specifications established by North American Rockwell for the Block II EPS cryogenic storage system (ref. 24) provide a requirement for operation of the heater circuit at 65 V dc from a GSE source for initial pressurization of the oxygen tank. For flight the specification calls for operation from a 28 V dc source. The specifications established by Beech Aircraft Corporation for the heater (ref. 25) stipulate standby operation from an ac source, later established as 65 V ac, for 50 minutes. While the heater is apparently satisfactory for its intended use, the specifications are not compatible with the intended use. The heater circuit is protected by a 15-ampere circuit breaker. Individual thermostats for each heater are also mounted on the inside of the support tube.

The thermostats were included in the heater circuit to prevent raising the pressure vessel wall temperatures above 90° F, the design temperature for the vessel walls. Such a condition (i.e., walls reaching temperature above 90° F under operating pressure) might occur if there was a very low quantity of oxygen left in the tank and it was desired to maintain pressure. There is no known instance of the thermostats ever having had to operate in flight.

A cross section of a thermostat is shown with the contacts in the open position in figure D3-14. The contacts would assume this position when the temperature of the thermostat reached $80^{\circ} \pm 10^{\circ}$ F. When the thermostat temperature is reduced to $60^{\circ} \pm 7^{\circ}$ F, the differential contraction of the two metals of the bimetallic disc causes the disc to snap through, assuming a convex up configuration. This forces the wave washer and the attached thrust pin to move upward. The movable arm containing the lower contact is pushed up by the thrust pin and the contacts are closed. The wave washer acts as a spring to keep the thrust pin bearing against the bimetallic disc. All of the moving parts of the thermostat are enclosed in an hermetically sealed case.

The thermostats are rated by the manufacturer as follows.

CURRENT RATING OF THERMOSTAT

Number of cycles	A p p l i e d v o l t a g e		
	30 V ac or dc	125 V ac	250 V ac
100,000	5.0 amp	2.0 amp	1.0 amp
50,000	5.5 amp	3.0 amp	1.5 amp
25,000	6.0 amp	4.0 amp	2.0 amp
10,000	6.5 amp	5.0 amp	2.5 amp
5,000	7.0 amp	6.0 amp	3.0 amp

The specifications established by North American Rockwell for the Block II EPS cryogenic storage system (ref. 24) provide a requirement for operation of the heater circuit at 65 V dc from a GSE source for initial pressurization of the oxygen tank. For flight, the specification calls for operation from a 28 V dc source. The specifications established by Beech Aircraft Corporation for the thermostat (ref. 26) stipulate a current-carrying requirement of 7 amperes without specifying voltage level or type of source (i.e., ac or dc). Acceptance test requirements imposed on the supplier by this latter document include dielectric testing, thermal shock, verification of operating temperatures of the thermostat, helium leak test, insulation resistance test, and visual and dimensional inspection. No requirement is imposed for acceptance test verification of the operational characteristics of the thermostat with respect to current-carrying capability or ability to open under load at any of the several voltages (65 V dc, 65 V ac, or 28 V dc) to which the thermostat will normally be subjected.

Qualification testing of the thermostats was accomplished as part of the overall testing of the assembled oxygen tanks. These tests included vibration, acceleration, and mission simulation. Operation of the heater circuit at Beech during the oxygen tank qualification program and for all normal acceptance testing is accomplished using 65 V ac for initial pressurization. Since this is done only when the tank is filled with liquid oxygen, it is highly unlikely that temperatures would be raised to levels that would cause operation of the thermostats. One instance of a single thermostat operating to open a heater was experienced in the First Mission Subsystem Qualification Test (ref. 27). At this time, heaters were being energized from a 28 V dc bus.

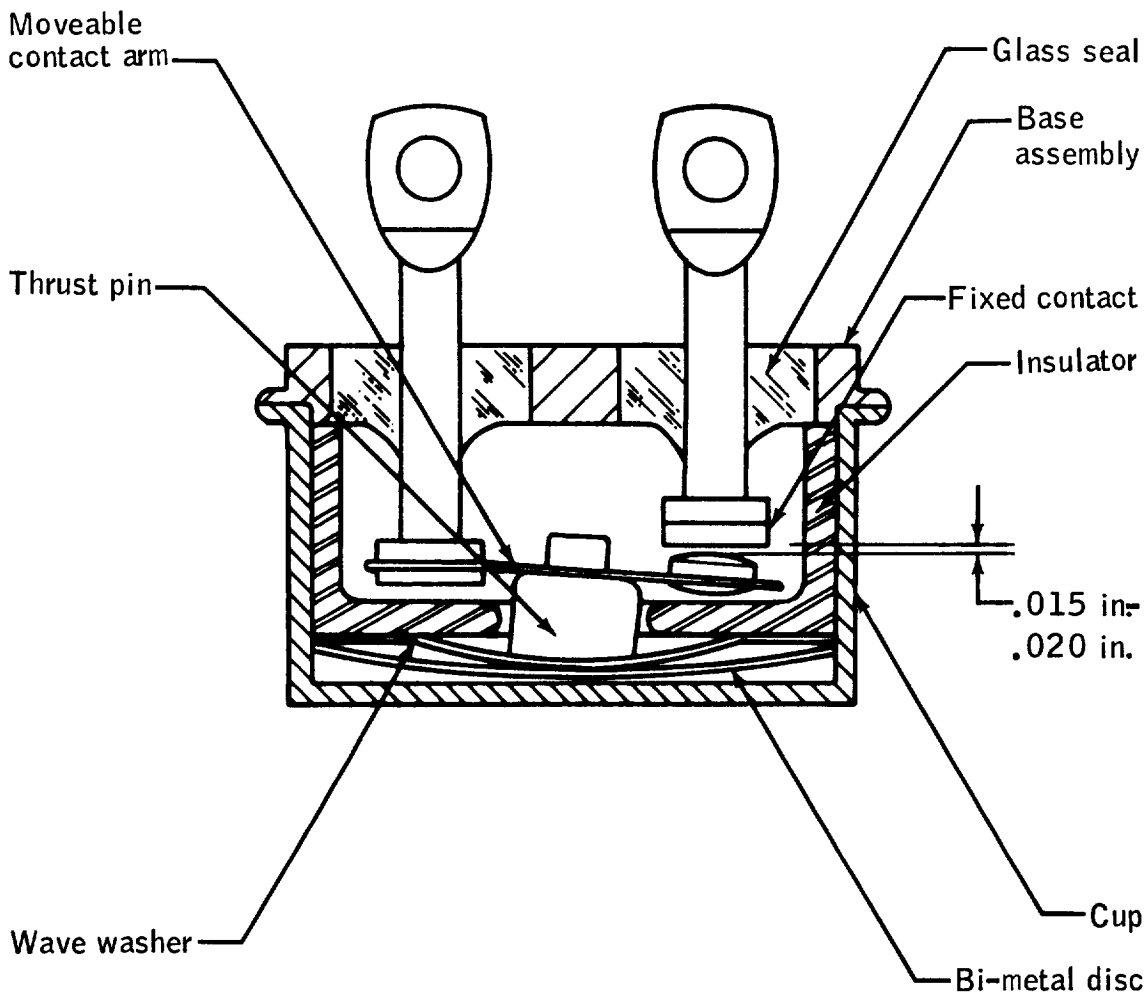

Figure D3-14.- Cross section of thermostat.

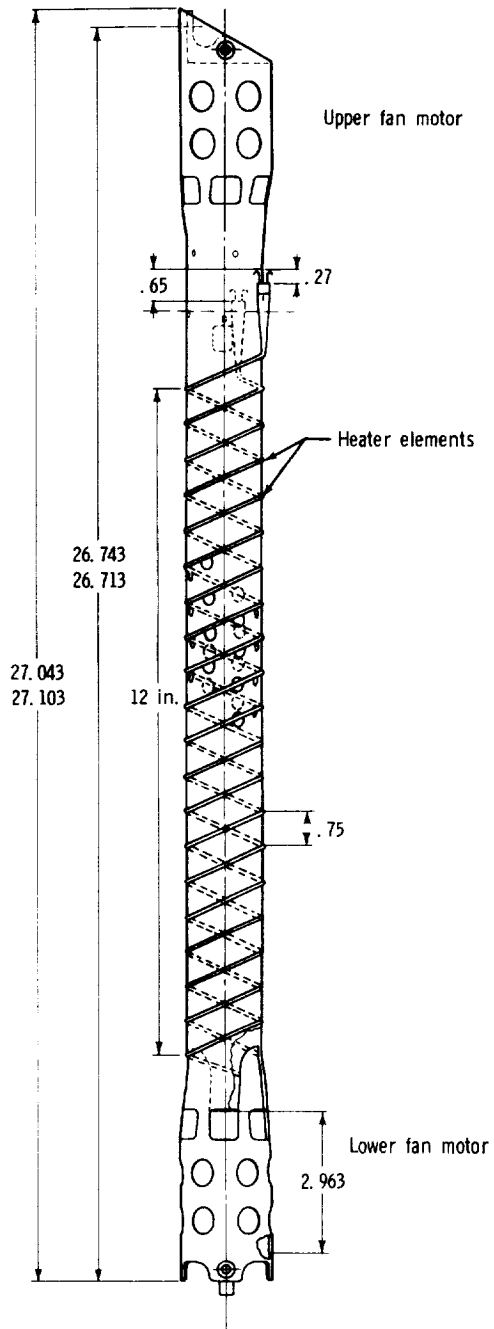

Figure D3-13.- Heater fan support.

All qualification and acceptance tests identified were primarily concerned with the repeatability of the thermostat actuation at the specified temperatures. No qualification or acceptance tests have been identified which would verify the ability of the thermostats to open the heater circuit when energized at 65 V dc.

The combination of incomplete, unclear, and therefore inadequate specifications of the thermostat with respect to voltage type and level and a test program that does not verify the ability of the switch to operate satisfactorily under service conditions constitutes a design deficiency. The fact that the ratings for the thermostat by the manufacturer (preceding table) contains no entry for 65 V dc indicates that service at this voltage was not intended.

At KSC, the heater circuits were intended to be operated at 65 V dc only when the tanks were full of liquid oxygen. Under this condition, the thermostats would not be required to actuate. A discussion of the possible consequences of actuation of the thermostat under load at 65 V dc is presented in a later section of this Appendix.

Fans

At the time the tanks were first designed, the knowledge of the behavior of fluids in zero-g was limited. It was believed that significant stratification of the fluid would occur during flight. Under these circumstances a number of difficulties could arise: a rapid pressure drop in the tank would be induced by the acceleration resulting from an SPS burn; the heaters might not be able to transfer heat uniformly to the oxygen; and, finally, serious errors in quantity measurement could result. The occurrence of any of these conditions could jeopardize flight safety or mission success. For this reason, the tanks were provided with two motor-driven centrifugal fans to mix the fluid and insure its homogeneity.

The two oxygen fan motors (fig. D3-15) are three-phase, four-wire, 200/115-volt, 400-hertz, miniature, open induction motors, driving centrifugal flow impellers. The minimum speed of the motors is 1800 revolutions per minute at a torque output of 0.9 ounce-inches. The motors are mounted at each end of the motor-heater support tube by a cantilevered attachment joined to the motor back plate. The motor clearance within the support tube wall is a nominal 0.01 inch. The stator windings and bearings of the motors are exposed to oxygen.

The stator windings are fabricated with number 36 American Wire Gage (AWG) wire, using a Teflon-coated ceramic insulation. The ceramic insulation is brittle and subject to breakage if proper tension is not used in fabricating windings or if sharp bends are made at the winding

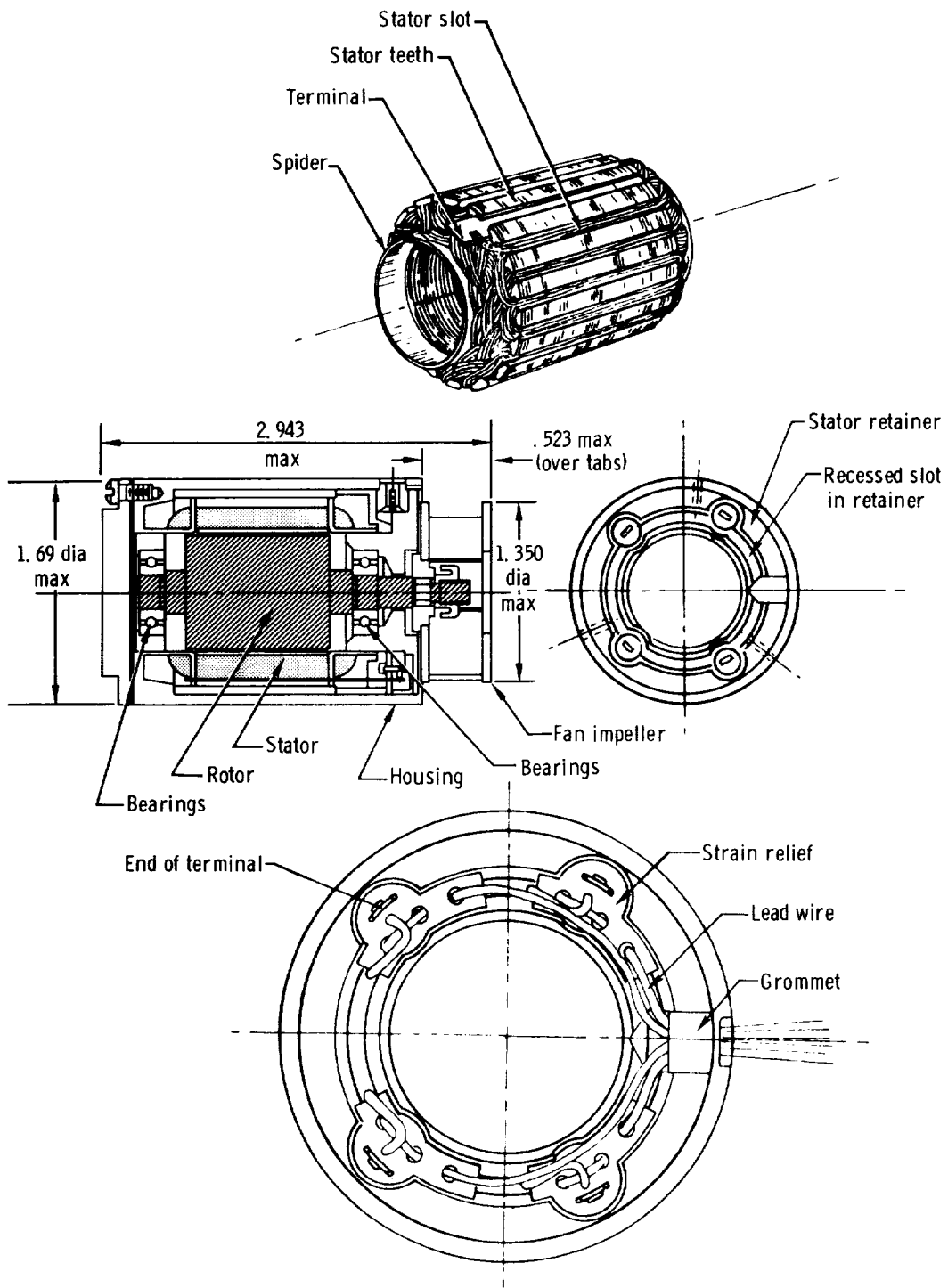

Figure D3-15.- Oxygen fan motor.

end turns. Acceptance testing of the wire is conducted on the first 100 feet of each reel. The wire is considered acceptable if no more than 10 breaks in insulation are exhibited in the sample when pulled through mercury at 25 feet per minute. The rejection rate for stator winding faults for motors processed early in the production run was substantial. Improved yield was achieved only by rigid adherence to the winding tension process control used in fabricating the windings, proper assembly techniques, and frequent in-process dielectric testing. Phase-to-phase short circuits or shorted turns within a single phase are more likely than phase-to-ground faults. A limited amount of insulation is provided between windings and ground. Phase-to-phase insulation is limited to the end turns. Considerable improvement was accomplished in the acceptance rate of motors built after the fabrication control techniques were developed (Appendix C). No problem was exhibited in the testing of the two motors finally installed for flight in oxygen tank S/N XTAA0008.

The motor design uses an insulation system in the windings which is subject to failure unless carefully controlled. The individual power leads to each fan motor are protected by 1-ampere fuses.

Temperature Sensor

The temperature sensor is a calibrated resistor, the resistance of which is proportional to temperature. The sensor is mounted to the upper glass-filled Teflon fitting of the capacitor probe. Since the calibrated input to the resistor is current limited to 1.1 milliamperes under fault conditions of the sensor, no problem would be anticipated with this unit.

Wiring

Wire sizes and types of wire used within the oxygen tank are shown in table D3-IV. The insulation used in all cases is Teflon with a nominal thickness of 0.010 inch. Distribution and arrangement of the wires is shown in figure D3-16.

The insulation on all wires within the tank is specified by reference 28 to conform to MIL-W-16878, Type E. The insulation thickness requirements of this specification establish the following:

<u>Condition</u>	<u>Insulation Thickness, in.</u>		
	<u>Minimum</u>	<u>Nominal</u>	<u>Maximum</u>
Nominal	0.008	0.010	0.012
With out-of-center tolerance	0.007	0.010	0.014

TABLE D3-IV.- WIRES INSIDE OXYGEN TANK

Service	Number	Size	Strands	Material	Insulation (b)	Color
Heater	4	AWG no. 20	19 x 0.008	Plated copper	Teflon	Violet White/violet Brown White/brown
Quantity probe	^a 2	AWG no. 20	19 x 0.008	Grade A nickel	Teflon	White Red (shielded)
Temperature sensor	4	AWG no. 22	19 x 0.0063	Grade A nickel	Teflon	Black Orange Green Yellow
Fan motors	8	AWG no. 26	19 x 0.004	Grade A nickel	Teflon	Red White Blue Black

^aInner probe lead nickel shielded, Teflon sheath.

^bAll insulation to MIL-W-16878, Type E.

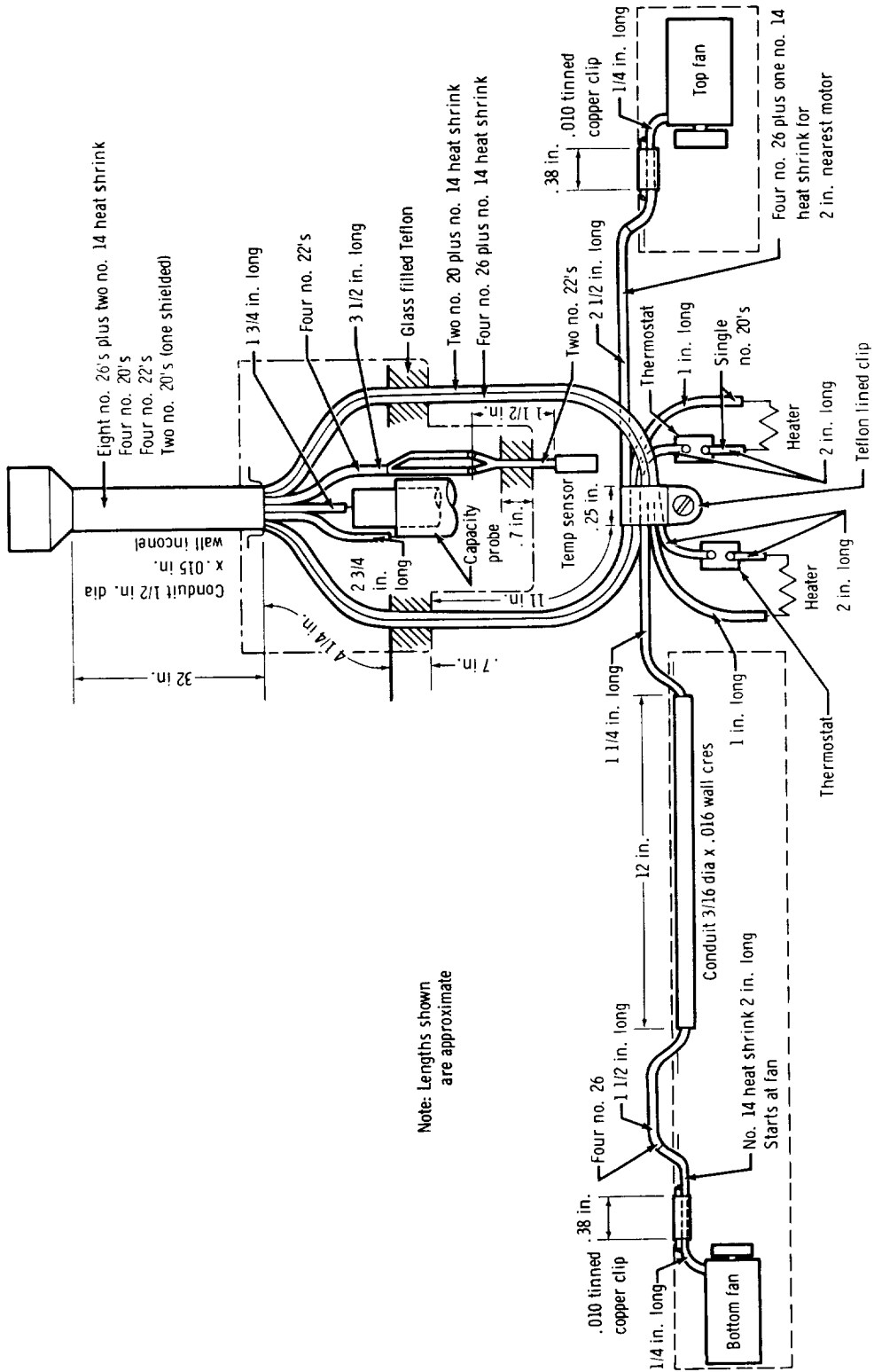

Figure D3-16.- Oxygen tank wiring distribution.

The mechanical design of the tank with respect to provisions for wiring is considered deficient. Damage to the wiring may be either insulation damage or conductor damage, portions of which cannot be inspected or adequately tested during or after assembly.

The four number 26 AWG wires for the fan motors are encased in 0.012-inch-thick shrink-fit Teflon tubing from the motor housing to a point 0.3 inch outside the heater-fan tube. The 0.012-inch shrink-fit tubing provides the protection for the wires at the point where the four-wire bundle crosses the machined sharp edges of the access hole in the heater tube (fig. D3-17). The shrink-fit tubing does not, however, alleviate the strain on the 90-degree bend of the wires at the motor housing. During assembly of the fan to the support tube, the four-wire bundle in the shrink-fit tubing may be forced against the machined sharp edges of the support tube at point "A" of figure D3-17. Two specimens of the support tube that have been examined show no removal of burrs at this point. Between the motor and the access hole in the support tube, the wire bundle is restrained by a 0.010-inch thick soldered copper clip.

The twisted lower fan motor leads (without shrink-fit tubing) reenter the support tube and traverse a 3/16-inch-diameter conduit for 12.0 inches before again exiting the support tube. No specification restraint on slack left in the bundle contained within the heater tube conduit was noted. The motor leads are in contact with the conduit, at least at the ends of the conduit, and exposed to local heat conditions of the heater elements.

Design changes were made between Block I and Block II configurations to provide independent circuits to each motor and heater within the oxygen tanks. Provision was made in the glass-filled Teflon separator on the quantity probe for access of the extra six wires to the upper end of the probe assembly. The conduit (1/2-inch OD x 0.015-inch wall) in the dome for wiring to the connector was not, however, increased in size.

During assembly of the tank, three bundles of six wires each are sequentially pulled through the conduit. The first bundle, consisting of the two quantity gage wires and the four temperature sensor wires, is pulled through the conduit along with the pull wires for the other bundles. The second and third bundles each consist of one set of motor leads encased in 0.012-inch shrink-fit tubing and one set of heater leads. The pull wires have a break-strength of 65 pounds. Since the third bundle of wire must be forceably pulled through the conduit, damage to wires in this bundle or the others may result which may not be detectable without physical inspection. Physical inspection cannot be accomplished with this design.

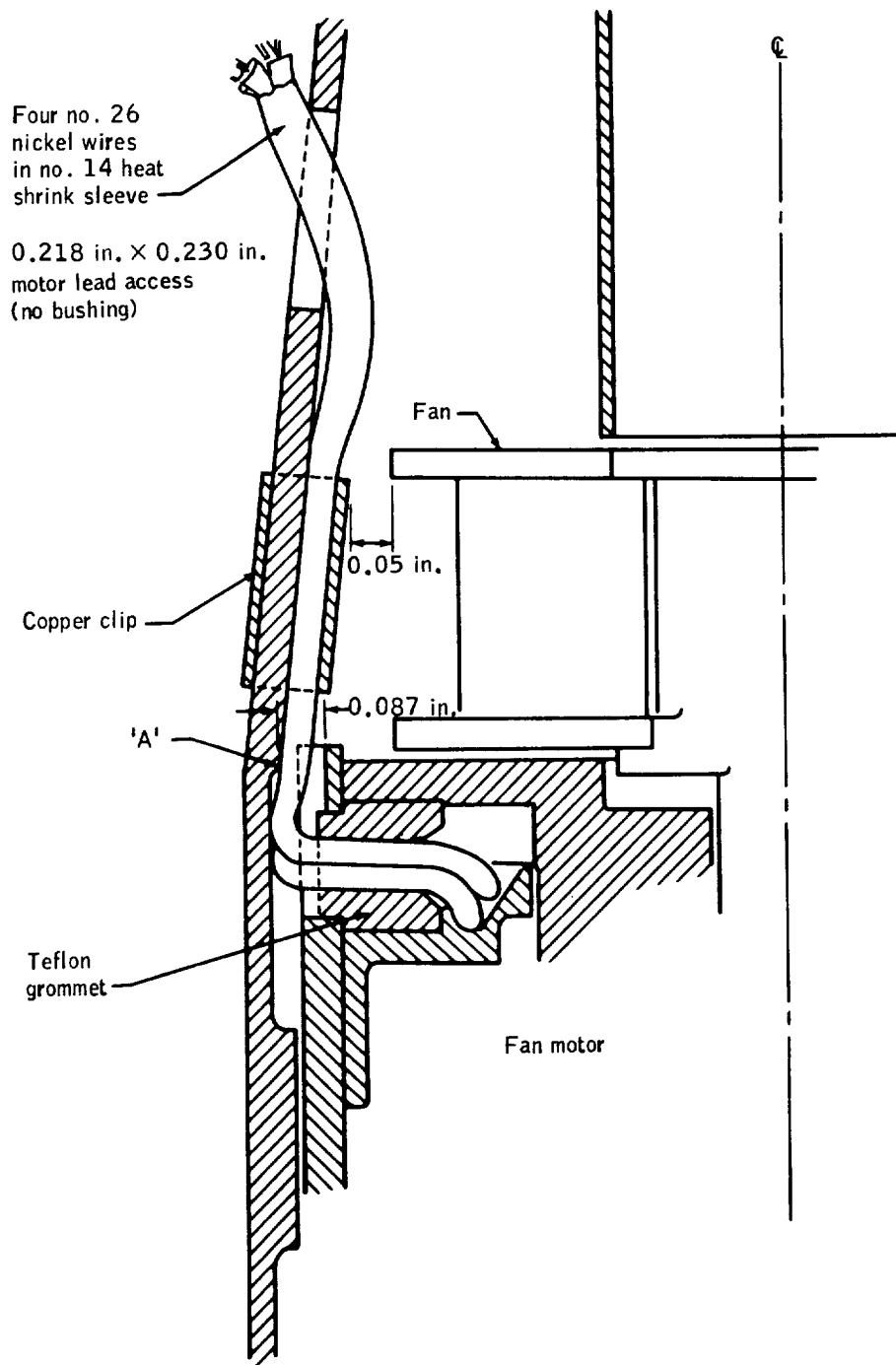

Figure D3-17.- Typical wire routing for fan motor (four times full size).

The calculated break strength of a number 26 AWG nickel wire is 11 pounds and elongation of 28 percent can be experienced before break. If the number 26 AWG wires do not share the load associated with pulling the bundle through the conduit, damage to the wire(s) will result before the pull wire breaks. Stretching of the wire results in local neck-down of both the conductor and insulation. In subsequent operation of the circuit, the locally smaller gage conductor can produce local hot spots and progressive deterioration of the insulation.

Discussion

All electrical power system wiring is protected by fuses or circuit breakers specified on the basis of wire size. Such devices will transmit their rated current without opening the circuit to either the load or a fault. The opening of the device to protect the circuit on overload is determined by an inverse time to over-current ratio that will open a large current fault in a short time, and a smaller over-current fault in a longer time. The protection afforded is to the wire and power system rather than to the connected end item.

The wiring in the oxygen tank has inherent potential for damage in assembly due to inadequate support, inadequate clearances, and thin Teflon insulation. It is well known (refs. 29 and 30) that Teflon insulation cold flows when subject to mechanical stress. The design of the tank internal installation exposes the insulation to potential progressive damage by cold flow where the wiring is placed near or at bends around sharp corners.

COMPATIBILITY OF MATERIALS WITH OXYGEN

It is well known that virtually all materials except oxides will react with liquid oxygen (LOX) under specific conditions. The tendencies to react and the rates of reaction vary widely. Most organic materials and the more active metals are sufficiently reactive with LOX to require careful attention to the condition under which they are used. Spontaneous reaction does not usually occur upon contact between a material and LOX; however, the sudden application of energy in the form of mechanical shock or electrical spark to the combination of LOX and a chemically active material will often result in violent reaction or rapid burning.

Classification Methods

A method commonly used to classify the relative reactivity of materials with LOX is described in references 31 and 32. Based upon this method, a specification, MSFC specification 106B, "Testing Compatibility of Materials for Liquid Oxygen Systems," was developed to establish acceptance criteria of materials for use in LOX and gaseous oxygen (GOX) systems. Materials meeting the requirements of paragraph 3.3 of the specification are said to be compatible with LOX. In this context it must be recognized that the term "compatible" describes only the relative reactivity of a material and does not describe an absolute situation.

Materials for use with LOX are selected from the "compatible" list of references 33 to 36 under the additional stipulation that the level of any potential mechanical shock is less than that associated with the impact test and/or that potential electrical energy sources are less than the ignition energy of the material in LOX. If a material is used with oxygen and a potential energy source, it must be determined by test that the energy available is less than that required to initiate the reaction. Furthermore, the test should represent the circumstances of use as nearly as possible.

For example, the pressures and temperatures of the oxygen to which the material will be exposed should be duplicated in the tests. Additionally, thickness and surface area of the material, as well as that of any backing material (such as may act as a heat sink, for example) should be duplicated. The latter is important because there are examples of materials changing from an acceptable rating to an unacceptable rating solely because of a change in the thickness used in a particular application. For some proprietary materials and composites whose composition may vary from batch to batch, it is necessary to repeat the compatibility tests for each batch. Elastomers are a good example of the latter category. In summary, the methodology for determining compatibility must be adhered to scrupulously to preclude self-deception.

Materials Internal to the Tank

The materials of the internal components of the oxygen pressure vessel have been identified from the records (ref. 37) and assessed as to suitability for use in the high-pressure oxygen environment. The types and estimated quantities of materials in each of these components within the oxygen tank are listed in tables D3-V through D3-IX.

Of the materials used in the tank, most have been subjected previously to compatibility testing in LOX in accordance with the methodology of references 31 and 32.

TABLE D3-V.- MATERIALS IN HEATER ASSEMBLY

Part name	Material	Estimated weight, lb
Tube assembly	321 stainless steel	1.39
Upper and lower motor support	302 stainless steel	.26
Silver braze	QQ-S-561, Class II	.062
Wire clamp	Tinned copper	.001
Thermostat doubler	QQ-A-327 (T6) aluminum alloy	.004
Grommet	Teflon (MIL-P-19462)	Negligible
Shim	321 stainless steel	.06
Bolts	302 stainless steel	.03
Screws	302 or 303 stainless steel	.04
Screws	302 or 304 stainless steel	.02
Nuts	Silver-plated 303 stainless steel	.002
Washers	321 stainless steel	.02
Washers	302 stainless steel	.007
Rivets	2117 aluminum	.001
Safety wire	304 stainless steel	Negligible
Heat shrinkable tubing	Teflon (TFE)	
	AWG no. 14 clear	.001
	AWG no. 14 white	.001
Solder	QQ-S-571, type AR Comp Sn 60-Pb40	Negligible
Screw	Stainless steel pw QQ-S-763	.04

TABLE D3-V.- Concluded

Part name	Material	Estimated weight, lb
Clamp	Stainless steel clamp with teflon cushion	Negligible
Drilube 822		Negligible
Wire	AWG no. 20, silver-plated copper	0.0278
Wire insulation and shrink fit tubing	Teflon	.0278
Disk blank*	Bi-metal (21 percent Ni 7 percent Cr Balance Fe and 36 percent Sn)	Negligible
Stationary contact*	0.010 fine silver on monel	Negligible
Movable arm*	0.004 Permannickel	Negligible
Welding cap*	Monel	Negligible
Insulator*	Alsimag 645 or Duco 9P-16	Negligible
Thrust pin*	Alsimag 35	Negligible
Mounting bracket*	302 stainless steel	Negligible
Wave washer*	Stainless steel	Negligible
Cup*	321 stainless steel	Negligible
Rivet contact* (movable)	Fine silver	Negligible
Base assembly*	321 stainless steel base	Negligible

*Thermostat parts

TABLE D3-VI.- MATERIALS IN DENSITY SENSOR PROBE

Part name	Material	Estimated weight, lb
Density sensor/assembly		1.9
Bracket	3003 Al alloy	.07
Spacer	25% glass-filled TFE Teflon	.01
Rivet	1100-H-14 Al alloy	.01
Rivet, solid	2117, 1100 Al alloy	.01
Grommet	Glass-filled Teflon	.01
Grommet	Glass-filled Teflon	.01
Sleeve	Red tubing - TFE Teflon Size 9 thin wall	.05
Spacer	25% glass-filled Teflon	.01
Solder	Tin/Lead 60/40	.01
Inner tube plug	25% glass-filled Teflon	.03
Rivet-semi-tubular	1100-H-14 Al alloy	.01
Outer tube	6063-T832 Al alloy	.20
Eyelet	Brass Comp 22 HD QQ-B-626	.01
Rivet	1100-H-14 Al alloy	.01
Terminal	Brass 1/2-H Comp. 1-QQ-B-613B	.01
Rivet, solid	110-H-14 or 2117 Al alloy	Negligible
Solder	QQ-S-571 (60/40)	.01
Sleeve, insulator top	Glass-filled TFE Teflon (25%)	.4
Rivet	1100-H-14 Al alloy	.01

TABLE D3-VI.- Concluded

Part name	Material	Estimated weight, lb
Sleeve support bottom	AMS-5542 Inconel X annealed	0.025
Insulator sleeve bottom	Fiber-filled TFE Teflon	.4
Rivet	1100-H-14 Al alloy	.01
Inner tube	6063-T832 Al alloy	.18
Terminal coax	Brass 1/2-H Comp 1-QQ-B-613B	.01
Wire	AWG no. 20, nickel, grade A	.0115
Wire, insulation and shrink fit tubing	Teflon	.0263

TABLE D3-VII.- MATERIALS IN DENSITY SENSOR PROBE TUBE ASSEMBLY

<u>Part Name</u>	<u>Material</u>	<u>Estimated weight, lb</u>
Tube assembly	Inconel X750	1.35
Sleeve connector	Inconel X750	.1
Electrical connector	Inconel X750	.25
Solder terminals	Gold-plated Inconel X750	.001
Tube	Inconel X750	.005
Adapter (fill) upper	Teflon (TFE)	.016
Adapter (fill) lower	Teflon (TFE)	.016

TABLE D3-VIII.- MATERIALS IN FAN MOTORS

Part name	Material	Estimated weight, lb
Screw	18-8 stainless steel	0.02
Plate, end	2024-T4 Al alloy	.04
Shim	302 stainless steel	.02
Shim	302 stainless steel	.02
Shim	302 stainless steel	.02
Bushing, bearing	303 stainless steel	.04
Bearing, ball	440C & Rulon "A"	.02
Bearing, ball	440C & Rulon "A"	.02
Spacer sleeve	303 stainless steel	.10
Lamination	Ludnum Al-4750-H no. 2 temp. RL fin.	.02
Insulator, stator slot	Teflon impreg. glass cloth	.02
Insulator, cell cover	Teflon impreg. glass cloth	.02
Terminal	Brass 1/2-H QQ-B-613	.02
Sleeving, heat shrinkable	Teflon TFE	.02
Compound, insulating	Liquinite Teflon FBC powder	.02
Wire, magnet	Teflon overcoated ceramic insulation over copper wire	.2
Housing	2024-T4 Al alloy	.2
Ring yoke	Transformer grade A silicon electrical steel	.02

TABLE D3-VIII.- Concluded

Part name	Material	Estimated weight, lb
Retainer stator	2024-T4 Al alloy	0.02
Plate, bearing	303 stainless steel	.16
Pin, spring	302 stainless steel	.02
Pin, spring	302 stainless steel	.02
Insulator	Teflon	.02
Grommet	Teflon	.02
Strain relief	Teflon impreg. glass cloth	.02
Sleeve, rotor	416 stainless steel QQ-5-763	.02
Shim, cover	302 stainless steel	.02
Plate, front	3003 aluminum alloy	.02
Vane, impeller	No. 12 brazing sheet	.02
Plate, back	No. 12 brazing sheet	.02
Hub	1100-F aluminum	.02
Lubricant	Drilube no. 822	.002
Safety wire	300 series stainless steel	Negligible
Wire	AWG no. 26, nickel, grade A	.0327
Wire insulation and shrink fit tubing	Teflon	.0518

TABLE D3-IX.- MATERIALS IN FILTER

<u>Part Name</u>	<u>Material</u>	<u>Estimated weight, lb</u>
Body	Inconel X750	0.016
Nut	304 stainless steel	.006
Washer	304 stainless steel	.002
Disc	302 stainless steel	.021
Seal	Teflon	.008

Some of the materials in the tables, however, have a questionable compatibility with LOX, under the criteria of MSFC specification 106B. These are the following:

- 60-percent tin, 40-percent lead solder
- Teflon (TFE) heat shrinkable tubing
- Drilube 822
- Rulon A
- Colored Teflon
- Teflon liquinite powder

The solder is listed as incompatible in the references 33 to 36. There are no test results for heat shrinkable Teflon tubing in the references. The last four materials have given inconsistent results in compatibility tests and exemplify the "batch" problem previously discussed. In addition to the above, some of the materials within the sealed thermostats (table D3-V) have apparently not been tested.

It must be emphasized that the data in the references cited are for tests in LOX at relatively low pressures. The compatibility of the materials under the conditions of service in the tank is thus not necessarily characterized by the referenced data.

The Teflon insulation used on the wiring within the tank is a prime suspect substance that burned inside Apollo oxygen tank no. 2 (Appendix F). Over many years of use, Teflon has been proven to be one of the most satisfactory nonmetallic materials for use in LOX. It will not react with LOX unless excited by energy sources such as extremely high impact energy (above 10 Kg-M) or a spark. Adiabatic compression tests up to pressure of the order of 10 to 12 ksi have failed to ignite Teflon. However, additives to Teflon to produce color or other property changes have been known to increase the susceptibility of Teflon to react with LOX.

It must be noted that all oxygen compatibility tests are conducted with the specimens in a scrupulously "LOX-clean" condition. Cleanliness of materials within oxygen systems is vital. Something as innocuous as the oils from a fingerprint can serve as the starting point for a chain of chemical reactions that can lead to a catastrophic failure. For this reason, the same standards of cleanliness employed in compatibility tests must be applied to flight systems.

Although the quantities of incompatible materials may be small, these materials can provide the mechanism for initiating other reactions. For example, in a recent test at MSC, 2 grams of Teflon were ignited in 900 psi oxygen, temperature -190° F, by means of a hot wire. This, in turn, ignited a piece of aluminum 0.006 inch by 0.75 inch by 0.75 inch that was in contact with the Teflon.

Titanium is not listed as a material used in the oxygen system; however, a titanium clamp of the same drawing number, distinguished only by a different dash number, is used in the hydrogen tank. The clamp is made in two halves. The identifying number is stamped on only one half. The titanium halves are matched, drilled, and bagged together at the manufacturers. If a half clamp made of titanium had been placed inadvertently in the oxygen tank, it could have contributed to the fire and subsequent tank failure as the clamp is attached to the boss area of the tank. Because of the bagging and other controls, it is unlikely that a titanium clamp found its way into an oxygen tank. It is poor design practice, however, to have dimensionally identical parts of different materials that may be interchanged and then installed in a potentially hostile environment.

Although not normally exposed to supercritical oxygen, the aluminized Mylar used in the oxygen tank vacuum annulus, and within the SM, is of interest in the investigation. Aluminized Mylar is not compatible with oxygen and were the pressure vessel or the tank internal tubing to fail, the Mylar in the annulus and/or the SM would be exposed to concentrated oxygen. If an ignition source is present, the Mylar would burn. If such burning were to have occurred within bay 4, it could have contributed to pressurization of the bay and consequent loss of the SM panel.

OTHER DESIGN AND SYSTEM CONSIDERATIONS

A number of other features and components of the oxygen tank system and of other spacecraft systems are discussed in the following sections.

Oxygen System Relief Valves

The oxygen tank relief valve was designed to protect the oxygen tank against the effects of potential malfunctions of the tank subsystem. Specifically, the valve was designed to relieve a pressure build-up resulting from the worst of the following three system malfunction conditions:

1. Heaters on GSE power supply at ground-rated conditions with a full tank and fans running with thermostats failing to open. This yields a heat input of 3002 Btu/hr, which would require a valve flow of 18 lb/hr to prevent exceeding 1010 psig.
2. Heaters on at spacecraft voltage level (28 V dc) and fans running with tank filled such that minimum dQ/dm exists (i.e., most critical condition for raising pressure). This yields a heat input of 685 Btu/hr and a valve flow requirement of 19 lb/hr.

3. Loss of vacuum in the annulus with the tank filled such that minimum dQ/dm exists. This yields a heat input of 935 Btu/hr which requires a valve flow capacity of 26 lb/hr.

The third condition requires the largest relief valve flow capacity and this was used to size the valve. It was also stipulated that the valve must pass this flow with the fluid at +130° F. These criteria were considered conservative because of the effects of flow through the relief valve on the heat leak, dQ/dm , and system temperatures.

A question arises from an examination of the three malfunction conditions assumed: Why was the case of heaters powered by ground support equipment (GSE) at critical dQ/dm not considered? Under such a circumstance, the heat input would be approximately 4-1/2 times that of condition 2 with a flow requirement increase in the same proportion. It was determined that it was not intended to ever use GSE power to the heaters except when the tank was full.

The design philosophy of the relief valve thus contemplated single-failure modes associated with anticipated malfunctions. It did not contemplate a catastrophic failure mode such as would be produced by combustion within the tank. This is not an uncommon design practice in the sizing of relief valves. In ground systems, however, in addition to relief valves, pressure vessels are frequently provided with large burst discs or blowout patches to protect against pressure rises that would result from conditions other than anticipated malfunctions.

The Block II relief valve was subjected to qualification testing as part of an oxygen system valve module qualification test program conducted by Parker Aircraft Company for North American Rockwell (NR) in March of 1967. Reference 38 describes the test program and the results. Briefly, the module, consisting of check valve (for no. 2 tank), relief valve, pressure switch, and pressure transducer, was subjected to the following tests: performance, vacuum, vibration, acceleration, humidity, and endurance cycling. Random vibration excitation was applied for 15 minutes for each axis. The acceleration testing was for 5 minutes in each of the +X, -X, +Y and +Z axes. During both vibration and acceleration tests, the various module elements were operated. The pressurizing medium was nitrogen at room temperature during all tests, except for one of the endurance tests which was conducted at -230° F.

The only discrepancy recorded for the test program was out-of-specification leakage of the check valve subsequent to the vibration testing. This was ascribed to the fact that fluid was not flowing through this normally open check valve during vibration which would be its condition during flight. This absence of fluid permitted the valve poppet to repeatedly strike the seat causing abnormal wear. Further, there was contamination present in the valve from the flex line used in the test

setup. This aggravated the problem. Because these factors were present, the test conditions were considered not representative of actual service conditions and the check valve performance was considered acceptable (ref. 39). It should be noted that the Block I valve was tested using oxygen as the fluid medium and that the changes from Block I to Block II valves were such as to not invalidate the materials compatibility demonstrated with the Block I systems.

A number of observations are warranted. No shock testing was required for the qualification of the relief valve. In view of the fact that other valves in the service module exhibited shock sensitivity during the Apollo 13 flight and the fact that only a few thousandths of an inch of poppet travel is required to open the relief valve fully, it would be valuable to determine whether the relief valve is sensitive to shock. It is possible that the relatively slow decay of oxygen tank no. 1 subsequent to the accident might be the result of a relief valve that failed to seat correctly after the shock.

In the qualification program there was no requirement for the relief valve to vent or relieve into a hard vacuum as it would have to in space. It is possible that under such conditions the oxygen would cool enough to solidify, thus plugging the orifice-like passage of the valve or the downstream lines that lead to the overboard exit, precluding further relieving by the valve. This is particularly important because the exit lines from both relief valves are manifolded prior to entering the overboard line. Were the common line to be plugged by solid oxygen by flow from one valve, it might prevent the second valve from relieving should it be required to do so. An experiment would be required to verify this.

Arrangement at Head of Tank

The head ends of the tank and the temperature sensor and quantity probe are shown in figure D3-18. One of the more significant features of the design is the arrangement of the connections in the fill line which routes the cryogenic fluid to the bottom of the tank, via the inner element of the quantity gage capacitor, and which permit the fluid to flow from the bottom of the tank during ground detanking. The manufacturing drawings of the elements of this connection, two Teflon adapters and an Inconel tube, allow a tolerance stack which is excessive. One combined worst case results in a connection which cannot reach from the fill tube connection in the tank head to the center element of the quantity gage capacitor. The other results in a connection length which prevents assembly of the probe to the adapter in the head of the tank. These are shown in figure D3-19. The tolerances on concentricity between the inner element of the capacitor and the outer shell of the probe are not known and are omitted from this figure. Inclusion would show an even worse situation than shown.

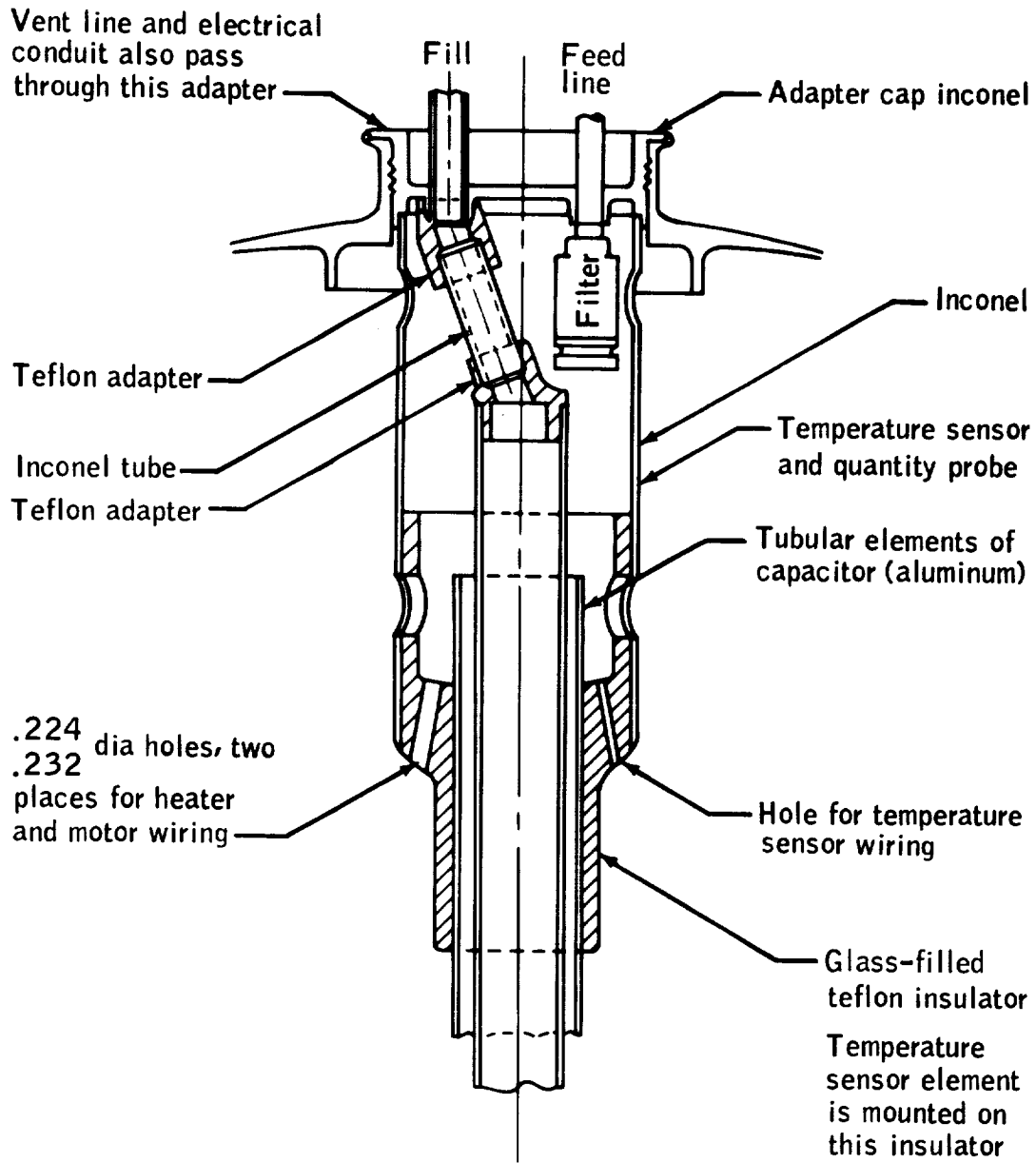
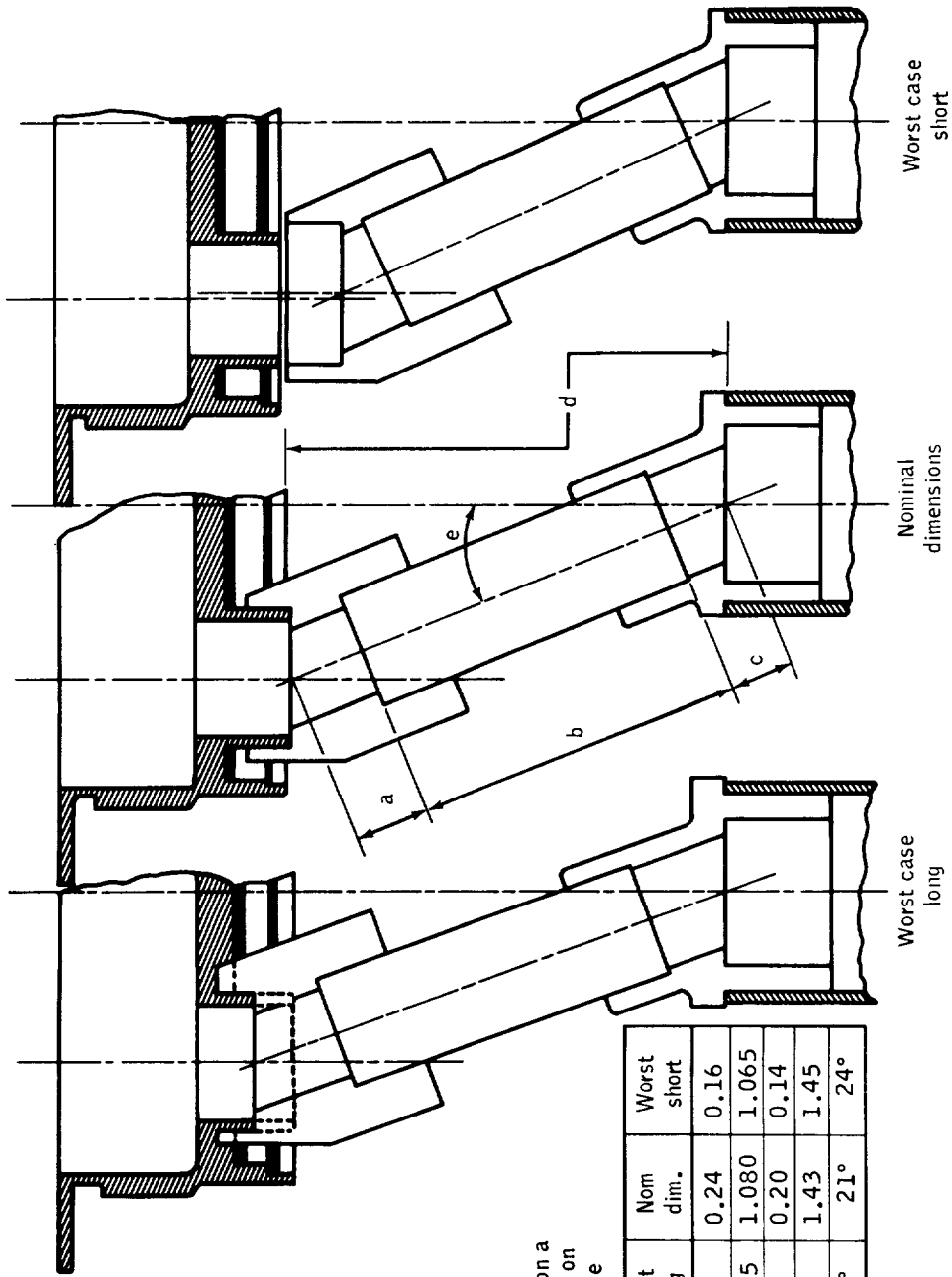

Figure D3-18.- Arrangement of head end of tank.



* Dimension a depends on value of e

Part	Worst long	Nom dim.	Worst short
a*	0.28	0.24	0.16
b	1.095	1.080	1.065
c	0.26	0.20	0.14
d	1.41	1.43	1.45
e	18°	21°	24°

Figure D3-19.- Possible variations in fill line connection.

The experience with the oxygen tank no. 2 in Apollo 13 (apparently normal detanking at Beech, but normal detanking not possible at KSC) suggests that the components used in the fill line connection were close to a worst-case short situation. Tests conducted recently at Beech show that near normal detanking is possible when considerable leakage is present at the joints in the connection, and that a substantial displacement of the top Teflon adapter relative to the fill line in the tank adapter cap is necessary to reproduce the KSC situation.

The manufacturing drawing tolerances are such that parts conforming to the drawings could result in an assembly which will not provide the proper connection. However, the probability of a combined worst case is extremely low. It is probable that the actual variations between production parts are significantly less than the drawing tolerances would permit, particularly the variations between parts within a common batch. Data have been requested on other similar parts to determine whether the variations from part to part are large or small, and whether the average tolerance stack found in practice leads to long or short connection assemblies.

The design is such that the task of assembling the probe to the adapter in the head of the tank (the connection is by four tack welds) is extremely difficult. All wiring must be loosely installed, and the majority of this originates from the fan/heater assembly which must be already installed within the tank shell. The fill line connection must be steered into place simultaneously with the insertion of the probe into the adapter, and this becomes a blind operation, complicated by the fact that thermal expansion coefficients dictate very sloppy fits between the Teflon adapters and the metal components of the fill line. This problem is dealt with at greater length in Appendix C.

One way to obviate this problem would be to redesign the internal components of the tank to permit bench assembly and thorough inspection of a single assembly, embodying all internal components and their plumbing and wiring, before introduction into the tank body. It is recognized that a redesign of this magnitude would largely destroy the foundation of experience, both ground and flight, with respect to the operational characteristics of the tank, but it is difficult to see how the internal details of the tank could be modified to provide the necessary degree of post-manufacturing inspectability without abandoning the present side-by-side arrangement of quantity probe and heater.

Dome Assembly

The tank dome assembly (fig. D3-20) forms a portion of the outer shell of the tank and houses the fluid lines and electrical conduit connecting the inner shell to the exterior of the tank. The upper surface of



Figure D3-20.- Oxygen shelf showing location of tank dome assemblies.

the dome contains the upper pinch-off tube, through which the annulus is evacuated, and a burst disc (rated at 75 psi \pm 7.5 psi) that provides burst protection for the outer shell in the event of leakage from the inner shell into the annulus. The arrangement of the fluid lines and electrical conduit within the dome is shown in figures D3-21 and D3-22. The coiling of these lines provides the high impedance path for heat leaks between the inner and outer shells of the tank. In the case of the large diameter vent line, this path is made longer by use of a double-walled tube outside the dome, with connection between inner and outer walls at the extremity of the projection of the tube from the tank.

Tube sizes are listed as follows (all dimensions in inches):

Oxygen Tank Tube Sizing

Vent tube	1/2 OD x 0.015 wall (inside coil cover) 3/4 OD x 0.028 wall (outside coil cover) Inconel 750 AMS 5582
Fill tube	3/8 OD x 0.022 wall Inconel 750 AMS 5582
Feed tube*	1/4 OD x 0.015 wall Inconel 750 AMS 5582
Electrical tube	1/2 OD x 0.015 wall Inconel 750 AMS 5582
Vapor-cooled* shield tube	3/16 OD x 0.015 wall Inconel 750 AMS 5582
Pressure vessel to vapor* cooled-shield tube	1/4 OD x 0.015 wall Inconel 750 AMS 5582

*These three tubes are joined sequentially to provide a single feed line which is looped around the tank inner shell to provide regenerative cooling for the vessel.

A total of 18 wires pass through the electrical conduit, eight AWG no. 26's, four AWG no. 22's, and six AWG no. 20's. The conduit is shown in figure D3-23. At the start of the investigation some members of the Panel felt that the unorthodox detanking procedure used at KSC could have resulted in unacceptably high temperatures in this electrical conduit due to resistive heating of the heater wires. This possibility is discussed in a later section.

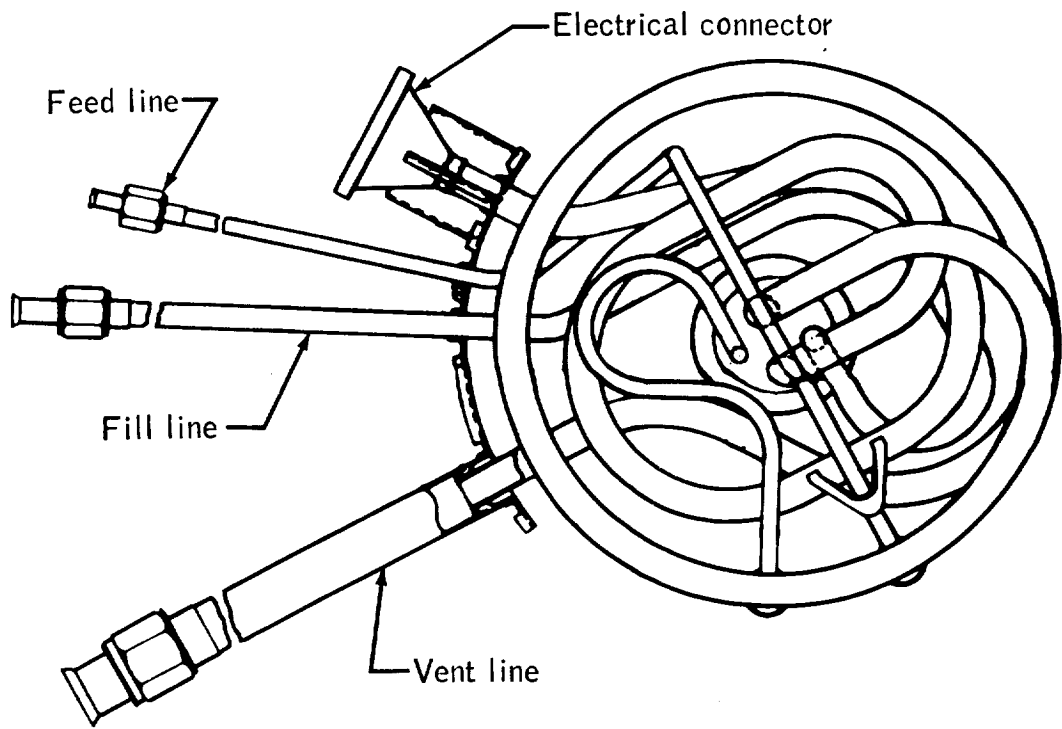

Figure D3-21.- Arrangement of tubing within tank dome assembly.

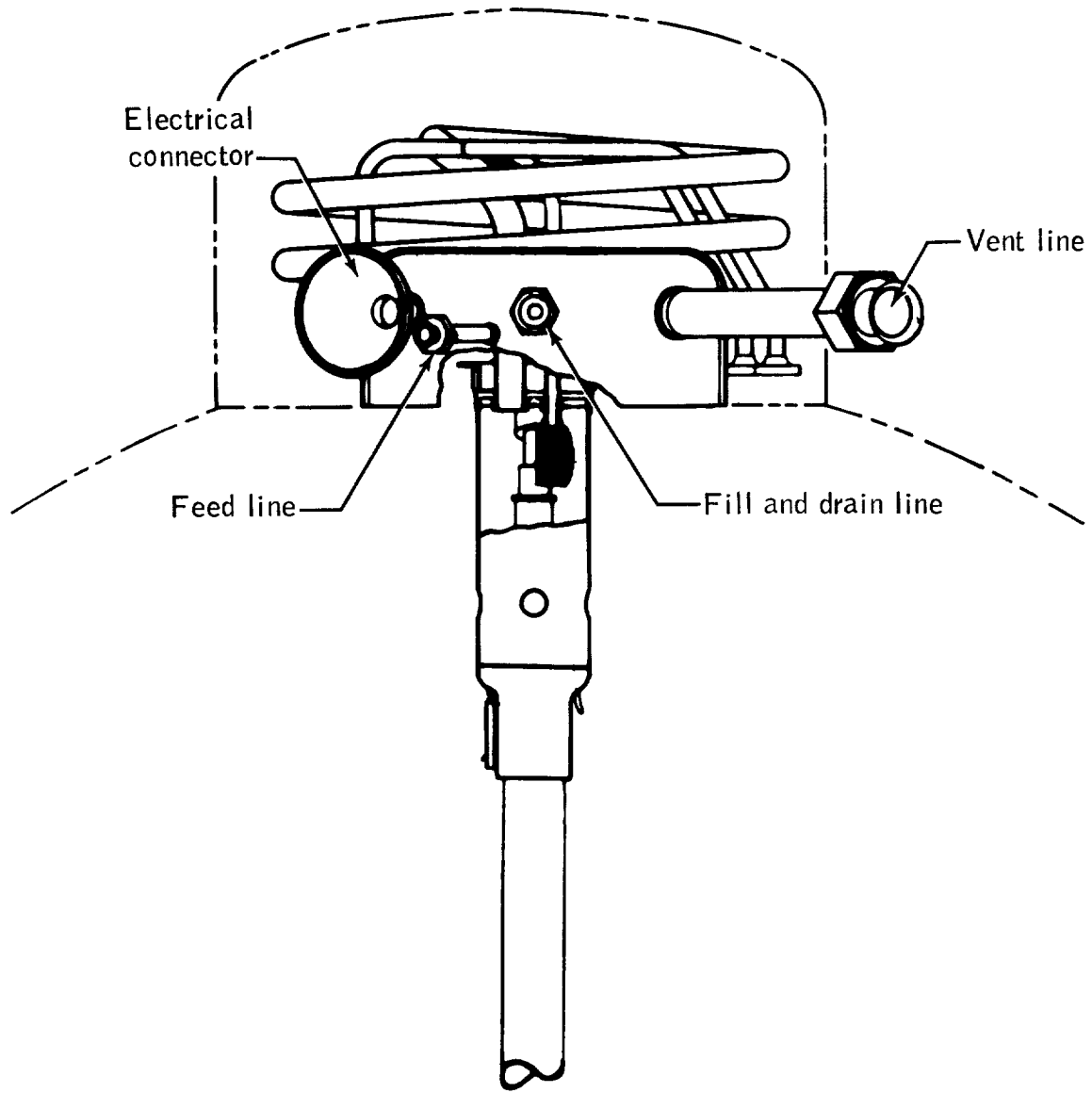

Figure D3-22.- Arrangement of tubing within tank dome assembly.

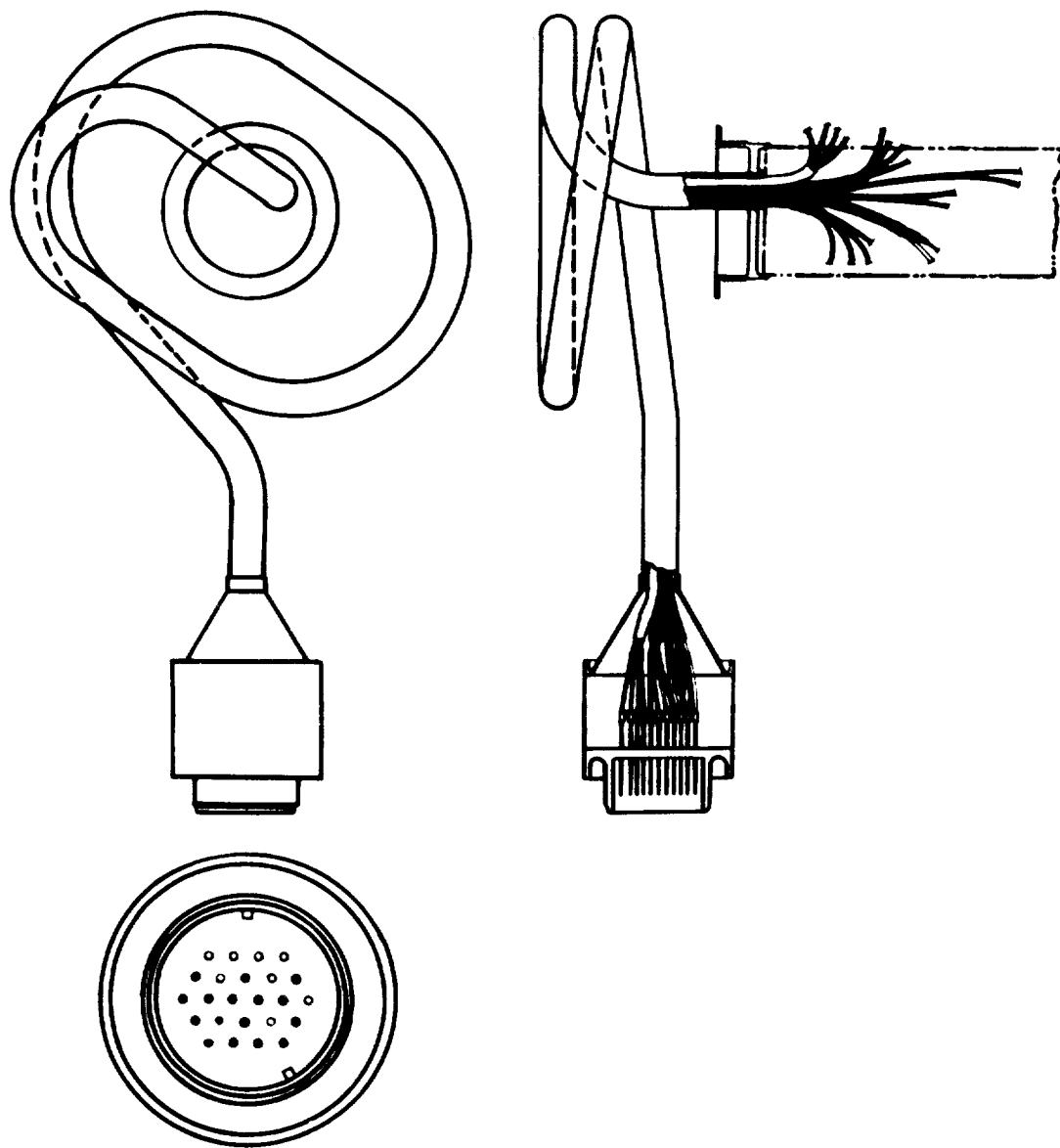

Figure D3-23.- Arrangement of electrical conduit.

The design of this portion of the tank results in a configuration in which it is not possible to perform visual inspection of wiring after assembly. In consequence, the possibility of damage, in many cases undetectable by normal quality assurance procedures, is significant.

Filter

The filter, which is welded onto the supply line projection into the tank, is located within the top of the quantity gage adapter when the tank is assembled. It consists of a series of thin washers stacked on a tube-like mandrel containing relatively large holes communicating with the interior of the tube. The washers have a series of raised projections on one surface arranged in concentric circles. The projections in each circle are staggered with respect to those adjacent circles. When stacked on the mandrel, the spacing between the washers provided by the projections present a tortuous path for the fluid to traverse in order to enter the center of the mandrel and thus provides a filtering action. The filter is rated at 175 microns and is intended to prevent particles greater than this size from entering the feed line.

The filter is of simple and reliable construction, and should provide only very small restriction to flow out of the tank. In the application, the two components protected by the filter are the relief valve and the check valve in the tank no. 2 valve module, both of which have moving poppets that must seat properly in order not to leak.

In normal circumstances the filter location is appropriate. Under abnormal circumstances, such as the combustion in tank no. 2 experienced on Apollo 13, the filter might become clogged with solid combustion products and thus preclude flow to the relief valves. Considering its construction, and ample flow area, this is not very probable. Tests are to be conducted to verify this.

Caution and Warning Provisions

Because of their design, the caution and warning system and the switch-controlled indicators ("talkbacks") did not present correct systems status to the crew during the Apollo 13 accident. As described in Appendix B, the following items are noted as examples:

1. The loss of oxygen to fuel cells 1 and 3 occasioned by closure of the oxygen shutoff valves was not indicated. The series logic used in the information system required that both the hydrogen shutoff valve and the oxygen shutoff valve be closed to activate the warning system. Simultaneous operation of the valves is appropriate to a deliberate shutdown of a fuel cell which should require no warning indication.

2. The crew was not alerted to the abnormal rise and subsequent loss of oxygen pressure in tank no. 2 because a normal out-of-limits operational signal (low hydrogen pressure) was in existence.

3. When power was lost to main bus B, the "talkback" indicators designed to indicate the state of RCS valves were no longer energized and could not properly indicate valve position.

Thus, accurate information as to the state of spacecraft systems, which is vital in time of emergency, was not provided by the caution and warning system.

ABNORMAL EVENTS IN THE HISTORY OF THE OXYGEN TANK

The oxygen tank which failed during the Apollo 13 mission had been subjected to two abnormal incidents prior to launch. The first occurred during spacecraft assembly. The oxygen shelf was "dropped" and the tank subjected to a shock load. The second abnormal condition occurred at KSC. An unorthodox detanking technique was used when the tank failed to empty during the normal procedures. The possible consequences of those incidents are discussed in the following sections.

Oxygen "Shelf Drop" Incident

The oxygen shelf which flew in Apollo 13 (Spacecraft 109) originally was installed in Spacecraft 106. On October 21, 1968, this shelf was in process of being removed from Spacecraft 106 for a rework of the vac-ion pumps. During the removal, the sling adapter (ground equipment) broke. The cause for the failure was traced to failure to remove one of the bolts attaching the shelf to the service module. At the time of the incident, it was assumed that the failure permitted the shelf outboard edge to fall back about 2 inches, at which point the shelf motion was stopped by the supports in the service module. An analysis of the stiffness of the oxygen shelf led to the prediction of a shock load of the order of 10g. The incident is reported in more detail in Appendix C. An analysis of the incident is contained in the files of the Board. The general conclusions are as follows:

1. The Apollo 13 oxygen "shelf drop" incident can be explained by assuming that the counterbalance weights on the 9EH-1275-100 sling were run out in an attempt to "balance" the effect of the shelf attach bolt (which was inadvertently not removed) to a point at which they caused the sling adapter to fail in bending.

2. The geometry and loading of the system at the time of failure would rotate the oxygen shelf about the remaining shelf attach bolt until the top of oxygen tank no. 2 impacted the underside of the fuel cell shelf, causing the observed dent in the shelf.

3. Tests to reproduce the dent in the fuel cell shelf have been conducted by striking a specimen of the shelf aluminum honeycomb material with an appropriately weighted tank pinch-off tube cover. The test results indicate that in order to reproduce the observed dent, a maximum acceleration of 7g was required.

4. On the basis of these data, it does not appear that the loads transmitted to the internal components of the tank during the "shelf drop" incident were of sufficient magnitude to cause any structural failure. One possible effect, however, could have been the displacement of a marginally secured connection between the fill line and the inner element of the quantity gage capacitor. Should this have occurred, it could have been the cause of the detanking anomaly experienced at KSC with oxygen tank no. 2 during the preflight operations on Apollo 13.

Detanking at KSC

The difficulty with the detanking of oxygen tank no. 2 subsequent to the countdown demonstration test (CDDT) is described in Appendix C. As noted in the preceding section, the inability to detank may be ascribed to a displacement of the short Inconel tube in that portion of the fill line located in the top of the quantity probe or the absence of this tube. Tests conducted at Beech Aircraft Corporation subsequent to the flight have demonstrated that if the tube is displaced laterally about 0.090 inch from its mating Teflon adapter, it is not possible to detank in normal fashion. The manufacturing tolerances for this sub-assembly have been discussed previously, and it is apparent that it is possible for such a displacement to occur if the parts are at appropriate extremes of the tolerances.

The nonstandard procedure used to detank oxygen tank no. 2 involved continuous power application to the heaters at GSE power supply voltage for 8 hours and 10 minutes. The fans were operated for all but the first hour and 20 minutes of this period. There is no conclusive evidence that either of the thermostats ever operated to open the heater circuits during this period. This occurred, despite the fact that the tank temperature sensor output, indicating ullage space temperature under the conditions of this procedure, was still rising when the instrument reached its readout limit of 84° F.

During this detanking, the GSE power supply was providing approximately 6.0 amperes to each of the two heaters at approximately 65 V dc

at the spacecraft. Tests conducted at MSC subsequent to the flight showed that when a thermostat attempted to interrupt a 6.0-ampere current at 65 V dc, the contacts welded shut. Whereas such contacts are rated by the manufacturer to interrupt at least a 6-ampere alternating current, under direct current conditions a considerable arc will be drawn and welding of the contacts will frequently result. At the time of this writing, three thermostats have been tested under voltage and current conditions like those experienced during the nonstandard detanking. All three failed by welding closed. Were the contacts in oxygen tank no. 2 thermostats to have failed in this manner, which seems highly probable, the heaters would have drawn current for the total period that the circuits were energized. There are a number of possible consequences of this condition. These are discussed in the following paragraphs.

Because the wiring in the conduit in the tank dome is of relatively small diameter for the current carried, it might lead to excessive wire temperatures by resistance heating, as this conduit represents a stagnant region with poor heat paths for removal of the heat generated. Were the temperatures to rise sufficiently, it could degrade the insulation to the point that the wire might be exposed. Preliminary calculations indicated that the temperature of the wires might rise to the point of insulation degradation and/or melting of soldered connections. A preliminary test using an actual conduit has indicated the temperature would not rise above about 325° F, which is well below the threshold temperature for wire insulation and solder damage. More definitive data on this possibility will be provided by a test planned for the near future at Beech Aircraft Corporation. A flight-type tank will be subjected to a reproduction of the nonstandard detanking process to determine, among other things, how hot the wiring in the conduit would get.

The second possible mode for damaging the wiring during the detanking is related to the pressure pulsing employed during the latter part of the detanking operation. When the tank is pressurized and quickly vented, the cryogenic oxygen will boil violently, probably producing "slugging" or "geysering" at the liquid-vapor interface. This action could easily flex the large unsupported loop of wire that results from the assembly process and thus could induce mechanical damage to the wire. This, too, must be confirmed by test before it can be considered as more than a possibility.

The third possibility for inducing wire damage applies primarily to the wiring in proximity to the heaters--especially the fan motor leads that are routed through the 12 inches of 3/16-inch diameter conduit that runs internal to the heater probe (see fig. D3-16). If the thermostat contacts failed by welding closed, as seems probable from the results of the thermostat tests described earlier, the heater probe metal temperatures would continue to rise, limited only by the heat balance between

that being generated by the heater and that being absorbed by the liquid and gaseous oxygen in the tank. Were the heater probe temperatures to rise above about 500° F, the wire insulation in its proximity would begin to degrade.

A test simulating prolonged application of power to heaters and fans with a heater probe half immersed in liquid nitrogen at one atmosphere pressure was conducted at MSC. After 8 hours, a thermocouple mounted directly on the outer casing of a heater element at a location where it was in contact only with the gaseous nitrogen in the ullage indicated a surface temperature of about 1000° F. At the same time, the temperature of the conduit wall reached 735° F.

Posttest inspection of the wiring indicated that the insulation had been seriously degraded (fig. D3-24). The insulation had become relatively brittle and had cracked in numerous places. Upon any subsequent flexing of the wire, the insulation would either break off or shift to widen the cracks, in either case exposing the conductor. Such an exposure would set the stage for a future short circuit. The state and nature of the degradation of the insulation depends on the temperature it reaches. It should be noted that this test was conducted in a nitrogen atmosphere, whereas the actual prolonged heater operation occurred in an oxygen environment. An oxygen environment is less benign chemically than one of nitrogen, and greater degradation than that observed might occur. The all-up test at Beech should provide more definitive information on this matter.

In summary, the nonstandard detanking procedure probably provided the mechanism for initiating the flight failure by causing sufficient damage to wire insulation to expose the conductor(s) of the fan motor leads. This would permit a short circuit to occur and initiate combustion within the tank. It is also possible that some solder was melted during the prolonged heating. Under the normal gravity conditions on the launch stand, it would be possible for a drop(s) of solder to fall free and solidify and remain in the tank. This could possibly lead to the subsequent shorting of the capacitor gage.

Discussion

As described in the preceding sections, the design of the oxygen tank as a pressure vessel is very adequate. It is constructed of a tough material well chosen for the application. There is no evidence of substandard manufacture of the particular tank involved, nor has any evidence been found of subsequent damage that would result in degradation of the structural integrity of the pressure vessel (as distinguished from the internal components of the tank).



Figure D3-24.- Photograph of wire damage.

If the telemetered pressure data truly represent the pressure the tank experienced at the time of the accident, it should not have failed structurally. The qualification burst test results indicate that the pressure vessel is capable of withstanding over twice the maximum pressure indicated at the temperatures recorded. The tubing is capable of withstanding even greater loads.

There was, as described in Appendix B, an observed abnormal increase in pressure and temperature in the tank. As has been discussed previously, there are combustibles, both metallic and nonmetallic, within the tank, as well as potential energy sources to provide ignition, especially of the Teflon insulation of the internal wiring. The method of assembling the tank system and the details of construction of the tank's internal components provide an opportunity for wiring damage. Also, there is an even greater probability that, in this instance, the non-standard detanking process created bare conductors. With such damaged wiring, a mechanism for creating a spark is provided and a consequence would be a fire within the confines of the tank. This would result in increases in the pressure and temperature within the tank.

There is sufficient Teflon within the tank to cause the internal pressure to rise above the burst strength of the pressure vessel were it all to be consumed. However, the locations of the Teflon components are such that igniting all of them is not very probable. The energy available from the combustion of the aluminum within the tank also exceeds that required to burst the tank. Tests conducted during the investigation indicate that enough electrical energy was available to initiate a combustion process within the tank under electrical fault conditions (Appendix F).

Among the possible ways that the tank integrity could have been lost, two are worthy of special mention. First, should combustion have existed within the electrical conduit, a relatively stagnant region with an intentionally poor heat conduction path, the conduit walls would have been heated quite rapidly. The conduit contains the greatest concentration of wiring and wire insulation within the tank. It was estimated that raising the conduit temperature to about 1500° F under the pressures prevailing during flight would cause the conduit walls to fail. This has subsequently been demonstrated in a test at MSC wherein the wiring insulation in an actual conduit was intentionally ignited under conditions simulating the conduit environment within the tank. In this test, local heating caused the conduit to fail a short time after initiation of combustion within the conduit. Such a failure would result in pressurization of the tank vacuum dome, leading to actuation of the blowout patch and loss of oxygen tank pressure.

The second possibility is associated with the reaction of aluminum with oxygen. This process has been described as quite violent (see Appendix F). Were the aluminum to have been ignited and if its reaction rate under the conditions within the tank were sufficiently high, the pressure could rise very rapidly and lead to pressure vessel failure at burst pressure levels. Such a pressure rise might not have been evidenced in the data because of the low sampling rate of the pressure sensor telemetry signal. Tests are required to verify this hypothesis.

A number of observations were made during the course of the Panel's activities that gave rise to further questions. It is recognized that many of these matters are of a subjective nature. Nonetheless, they are considered worthy of comment in this report.

Oxygen tank no. 1 lost pressure subsequent to the failure of tank no. 2. The mechanism of damage to tank no. 1 has not been established. It is assumed to be the result of a line or valve failure in the tank no. 1 system. The two tanks and their associated hardware represent, to a large degree, redundant systems. They are, however, in great part colocated. For example, the tanks are adjacent to one another, the system valves are grouped in a common housing, the fluid lines and wiring are routed parallel to one another in close proximity. Systems other than the oxygen subsystems have similar configurations. Such practice provides the possibility of inducing failure in a redundant system by a failure of its companion. This is a most complex subject and difficult to assess. It is also recognized that much of the hardware for Apollo has already been built. There appears to be a need for a review and evaluation of this matter.

No evidence has been found that indicates that shock testing of components and/or subsystem assemblies is a normal qualification requirement for Apollo service module hardware. The flight environment contains shocks of a considerable magnitude during events such as staging of the launch vehicle. That the effects of such environments on system components were recognized is evidenced by the use of holding current on the fuel cell reactant shutoff valves, for example. Shocks can be applied to hardware during shipment and normal handling, even though elaborate precautions in the form of special shipping containers, labels, and cautionary tags to alert transportation groups to the sensitivity of the shipment are employed. Good design and development practice includes experimental determination of margins against damage under such circumstances. Again, there appears to be a need for a review and evaluation of the susceptibility of the components in the spacecraft to all credible shock levels they may encounter in their service life so that the margins of safety inherent in their design may be established.

RELATED SYSTEMS

As a result of the Apollo 13 accident, a critical examination of other Apollo systems is being conducted by MSC to insure that the potential for a similar mode of failure does not exist elsewhere in the spacecraft. A member of the Design Panel was present at the MSC review meetings. The following is a summary of the activity and a status of the MSC effort.

The review was limited to selected systems in the following major Apollo elements:

Command and service module

Ascent and descent stage of the lunar module

Government furnished equipment

Ground support equipment

As an aid in determining which subsystems should be reviewed, a tabulation of all pressure vessels in these major elements was assembled (table D3-X). The cryogenic oxygen tank, which is reviewed in earlier sections of this report, was excluded from this review. Table D3-XI lists those systems and major elements that were selected for review. All vessels and oxygen and propellant line components in the selected systems are to be analyzed. The primary emphasis during the review is on the oxygen and oxidizer systems and the identification of all sources of energy--both internal and external to the system--that could result in an excessive pressure rise and possibly result in the failure or degradation of a system. Sources of energy which were considered were electrical, mechanical, and solar.

Pressure Vessels

The pressure vessels are of concern in that they represent large energy sources in the event of their catastrophic failure. Qualification records were reviewed and analyzed to determine the actual factors of safety demonstrated by burst test, as well as the characteristics of the failure modes. The failure modes of the pressure vessels have been categorized as explosive, uncertain, and benign. With these data, an assessment was made of those components that might be damaged by the explosion of a tank and the effect of this explosion on the vehicle systems and the crew.

TABLE D3-X.- PRESSURE VESSELS

Tank	System/location	Number	Normal operating pressure	Media	Material
Water	ECS/LM D/S	1	47.3	N ₂ /water	6061 T6 aluminum
GOX	ECS/LM A/S	2	890	Oxygen	718 Inconel
Water	ECS/LM A/S	2	27.3	N ₂ /water	6061 T6 aluminum
GOX	ECS/LM D/S	1	2690	Oxygen	D6ac steel
Oxidizer	Propulsion/LM A/S	1	184	Helium/N ₂ O ₄	6AL-4V titanium
Helium	Propulsion/LM A/S	2	3050	Helium	6AL-4V titanium
Fuel	Propulsion/LM A/S	1	184	Helium/Aerozine 50	6AL-4V titanium
Helium	Propulsion/LM RCS	2	3050	Helium	6AL-4V titanium
Fuel	Propulsion/LM RCS	2	180	Helium/Aerozine 50	6AL-4V titanium
Oxidizer	Propulsion/LM RCS	2	180	Helium/N ₂ O ₄	6AL-4V titanium
Helium	Propulsion/LM DPS	1	1640	Helium	6AL-4V titanium
Helium	Propulsion/LM DPS	1	400-1550	Supercritical helium	5AL-2 1/2 Sn titanium
Fuel	Propulsion/LM DPS	2	248	Helium/Aerozine 50	6AL-4V titanium
Oxidizer	Propulsion/LM DPS	2	248	Helium/N ₂ O ₄	6AL-4T titanium
Battery	EPS/LM A/S	2	3-5	KOH/Ag-Zn	Magnesium
Battery	EPS/LM D/S	4	3-5	KOH/Ag-Zn	Magnesium
Battery	EPS/LM ED	2	15	KOH/Ag-Zn	Epoxy glass
Hydrogen	EPS/SM	2	225	Supercritical hydrogen	5AL-2 1/2 Sn titanium
Fuel	Propulsion/SM-SPS sump	1	186	Helium/Aerozine 50	6AL-4V titanium
Fuel	Propulsion/SM-SPS storage	1	186	Helium/Aerozine 50	6AL-4V titanium
Oxidizer	Propulsion/SM-SPS sump	1	186	Helium/N ₂ O ₄	6AL-4V titanium
Oxidizer	Propulsion/SM-SPS storage	1	186	Helium/N ₂ O ₄	6AL-4V titanium
Helium	Propulsion/SM-SPS	2	3600	Helium	6AL-4V titanium

TABLE D3-X.- PRESSURE VESSELS - Continued

Tank	System/location	Number	Normal operating pressure	Media	Material
Nitrogen	Propulsion/SM-SPS	2	2350	Nitrogen	AM 350 steel
Oxidizer	Propulsion/SM Primary RCS	4	186	Helium/N ₂ O ₄	6Al-4V titanium
Oxidizer	Propulsion/SM Secondary RCS	4	186	Helium/N ₂ O ₄	6Al-4V titanium
Fuel	Propulsion/SM Primary RCS	4	186	Helium/MMH	6Al-4V titanium
Fuel	Propulsion/SM Secondary RCS	4	186	Helium/MMH	6Al-4V titanium
Helium	Propulsion/SM RCS	4	4150	Helium	6Al-4V titanium
Oxidizer	Propulsion/CM RCS	2	291	Helium/N ₂ O ₄	6Al-4V titanium
Fuel	Propulsion/CM RCS	2	291	Helium/MMH	6Al-4V titanium
Helium	Propulsion/CM RCS	2	4150	Helium	6Al-4V titanium
Battery	EPS/CM-entry	3	0-20	KOH/Ag-Zn	Epoxy laminate
Battery	EPS/CM-pyro	2	15	KOH/Ag-Zn	Epoxy glass
Nitrogen	EPS/SM-fuel cell	3	1500	Nitrogen	AMS 4910 titanium
Nitrogen	EPS/SM-fuel cell	3	53	Nitrogen	5Al-2 1/2 Sn titanium
Nitrogen	SIM/SM	1	4000	Nitrogen	6Al-4V titanium
Oxygen	ECS/CM-surge	1	900	Oxygen	718 Inconel
Oxygen	ECS/CM-repress	3	900	Oxygen	718 Inconel
Glycol	ECS/CM	1	50/18-27	Glycol/oxygen	6061 T6 aluminum
Potable water	ECS/CM	1	18/22 18/27	Water/oxygen	6061 T6 aluminum
Waste water	ECS/CM	1	18/18-27	Water/oxygen	6061 T6 aluminum
Accumulator	ECS/CM	2	100	Water/oxygen	6061 T6 aluminum
Fire extinguisher	Crew/CM	1	85	Water/freon 12	718 Inconel
Nitrogen	Hatch/CM	2	5000	Nitrogen	718 Inconel
Nitrogen	Probe/CM	4	5000	Nitrogen	718 Inconel

TABLE D3-X. - PRESSURE VESSELS - Concluded

Tank	System/location	Number	Normal operating pressure	Media	Material
Oxygen	PLSS	1	1020	Oxygen	301 cryoform
Water	PLSS	1	3-8	Water/oxygen	6061 T6 aluminum
Battery	PLSS	1	5-8	KOH/Ag-Zn	Titanium
Oxygen	OPS	2	5880	Oxygen	718 Inconel
Carbon dioxide	Raft	2	1000	CO ₂	301 cryoform
Carbon dioxide	Life vest	2	1000	CO ₂	Steel
Oxygen	PAD pack	5	3600	Oxygen	301 cryoform
Helium	Snap 27 fuel capsule	1	4-700	Helium	Haines 25
Helium/ nitrogen	Seismic experiment	1	333	10% helium 90% nitrogen	AM 347
Air	Crew/LGEC camera	1	500	Air	6061 T6 aluminum
Hydrogen	GSE/KSC	1	20	Liquid hydrogen	6061 T6 aluminum

TABLE D3-XI.- Subsystems Selected for Review by MSC

Command module

Environmental control
Reaction control
Electrical power
Mechanical

Lunar module descent stage

Environmental control
Descent propulsion
Electrical power

Service module

Service propulsion
Reaction control
Electrical power

Government furnished equipment

Crew equipment
Lunar surface experiments
Scientific instrument module

Lunar module ascent stage

Environmental control
Reaction control
Ascent propulsion
Electrical power

Ground support equipment

Hydrogen servicing dewar
PAD emergency air pack
High-pressure oxygen line components
Oxygen/fuel line components with
electrical interface

The explosive failure of a pressure vessel on the spacecraft, depending upon the energy stored in the vessel, could result in effects ranging from localized damage to loss of spacecraft and crew.

The following approaches were considered to provide protection to the spacecraft and crew from the catastrophic explosion of a major pressure vessel:

1. Isolation of the pressure vessel by separation.
2. Controlled failure provisions by changes to the vent or relief system to permit rapid depressurization.
3. Containing the blast by the addition of shielding by heavier or strengthened walls.

It was concluded that it would be theoretically possible to provide increased, but not total, protection for the spacecraft against the catastrophic explosive failure of a pressure vessel if major vehicular and pressure vessel changes were made. There are many practical limitations which preclude the provision of total protection against the catastrophic explosive failure of a pressure vessel. To determine the effect on the spacecraft of a nonexplosive or a benign leakage-type failure of a pressure vessel, the components and materials in the immediate vicinity of the tank in question were identified. Both the LM and CSM have nonmetallic materials which probably would not survive if they were exposed to propellants as the result of a pressure vessel failure. It is not feasible to use materials throughout the spacecraft which are totally compatible with all fluids that they could encounter following a primary failure. Considering the vehicle and systems effects of a pressure vessel failure (leakage or explosive), it is clear that neither containment nor complete nonmetallic material compatibility can be provided in the form of practical or reasonable solutions for spacecraft and crew protection against all tank failures. A tank failure would result in at least the abort of a mission, even through the damage from a pressure vessel could be contained.

The review of the pressure vessels of table D3-X identified a direct electrical interface or exposed wiring in the media as follows:

1. Propellant quantity gaging systems in the lunar module descent stage tanks and in the service module service propulsion system (SPS) tanks.
2. Capacitance gage, heaters, motors, and temperature sensor in the cryogenic hydrogen tanks in the service module.

3. Quantity gage in the potable and waste water tanks in the command module.

4. Quantity sensing gage in the GSE hydrogen dewar.

The MSC is conducting an analysis and plans to perform tests on the quantity gaging systems to insure that the combination of fuel and energy potential for ignition are understood and represent no hazard. Associated with this is a review of the circuitry and circuit protection. The waste and potable water tanks are being reviewed to determine the hazards, if any, of the electrical circuit and the advisability of deleting the quantity gage.

The cryogenic hydrogen gas pressure vessel was reviewed and it was verified that the manufacturing and assembly techniques, as well as the arrangement of the internal components, are very similar to those of the oxygen tank. The same potential for an electrical malfunction in the hydrogen tank exists as did in the oxygen tank. Mission rules have been reviewed and it was determined that the minimum failure in a hydrogen tank which would result in a mission abort would be the loss of two heaters and one fan. The MSC is planning to conduct tests to determine if an electrical malfunction can induce a sustained reaction between hydrogen and materials contained within the tank. Tests will also be conducted to determine if both heaters would fail following an electrical malfunction. Structural and materials compatibility analysis and reviews indicate that the titanium alloy (5 Al, 2-1/2 Sn) as used does not experience hydrogen embrittlement.

The remaining pressure vessels were reviewed to determine those that had internal components, which could expose an electrical interface to the contained media following a single failure. In addition, the non-metallics that might be exposed following such a single failure are being identified to insure that they are compatible with the media at operating conditions.

The review of the LM pressurized tanks disclosed that helium and oxygen tanks are isolated from their relief valves during the translunar coast period. Under normal flight conditions at ambient temperatures the pressure rise in the tanks is relatively insignificant. If protective thermal blankets on the LM should be lost or damaged, the pressure rise could be significant. A Grumman study indicates that if the complete loss of thermal blankets occurred in the areas of the following tanks they could reach burst pressures during translunar coast:

Ascent stage oxygen

Ascent propulsion system helium

Reaction control system helium

Descent propulsion system helium

Loss or damage of a thermal blanket could probably be determined during transposition and docking on all except the descent helium tank. It should be noted that no rational failure mode has been identified which could result in the loss or damage of a thermal blanket.

Line Components

The line components that are integral to the systems in table D3-XI are also being examined to determine those with and those without an electrical interface. The electrical interfaces are of two types, direct exposure to the media and exposure following a single failure. In addition, all nonmetallics near a potential ignition source will be identified and evaluated.

The only component which has been identified as of this date as having nonmetallics and a direct electrical interface in high-pressure oxygen is the fuel cell reactant shutoff valve. The Teflon-coated wires internal to this valve, when energized, carry steady-state currents of 2 amperes and transients of 10 amperes in a 900 psi oxygen environment. The circuit protection consists of a 10-ampere circuit breaker. During the launch and boost phase, a current limited circuit, approximately 0.5 ampere at 9 to 10 volts, is applied to the "open" coil to insure that the valve remains in the open position. The valve position sensor switch, which is also internal, is continuously energized during the entire mission from a 28-volt circuit protected by a 10-ampere breaker. This valve is now the subject of an intensive review by MSC and the contractor. There is no indication that this reactant valve had any internal malfunction during the Apollo 13 accident other than the shock closure.

Components without direct electrical interfaces are also being examined to identify those in which nonmetallic materials are normally exposed to the media and those in which nonmetallic materials could be exposed following a single failure. To determine the probability of a single failure in static components such as temperature and pressure transducers, the acceptance and certification testing of critical elements is being reviewed. It has been ascertained that component elements such as bellows, probe cases, and internal diaphragms are designed and tested for pressure levels far in excess of system usage. The reliability reports confirmed that leakage failure of these elements has not occurred on Apollo flight hardware.

In addition to normal material compatibility determinations, those components which have nonmetallics used in impact applications are being identified and it is planned that, where necessary, additional testing will be conducted in the media at appropriate operating conditions to determine that there are no impact-sensitive applications.

Low Pressure Oxygen Systems

Following the Apollo 20⁴ accident, the metallic and nonmetallic materials in the cabin of both the command module and lunar module were subjected to an intensive review. As a result of the research and testing, the materials within the LM and CM were modified or changed to reduce the probability of an ignition and to minimize the combustion or propagation of fire in the cabin. Considering the redesign that was accomplished and the continuing rigorous control of materials added to the spacecraft cabins, the low-pressure oxygen systems (less than 25 psi) were not reevaluated during this current investigation by MSC.

Electrical Power System--Batteries

Both the LM and the CSM use the same type battery to initiate the pyrotechnic functions. A review of the records indicated that the G-10 laminated glass epoxy battery case had not been qualified as a pressure vessel. The case is protected by a relief valve which operates at 30 ± 5 psi. In the event of a relief valve failure, and case pressurization to rupture, potassium hydroxide could be released. A certification program will be conducted to establish the strength of this battery case and procedures established for the acceptance proof testing on all flight batteries prior to each mission.

Ground Support Equipment

This review is structured to identify all pressure vessels and line components in propellant and high-pressure oxygen systems with direct electrical interfaces and the associated metallic and nonmetallic materials. All high-pressure oxygen, gaseous and liquid, valve seat material will be identified as well as any other application of nonmetallic material in an impact loading application. This MSC review is limited to equipment supplied by North American Rockwell and Grumman.

During the review of the GSE, it was also established that cleaning and filtering techniques used have been generally effective in limiting contamination. Shock-sensitive materials have been detected in the liquid hydrogen dewar in small quantities (less than 1 mg/liter), which are within specification limits for nonvolatile residuals. The source

and quantity of the shock-sensitive materials should be identified, as well as the potential for a buildup in concentration. It is recognized that contamination is not considered as a candidate cause for the Apollo 13 accident.

Certification

The certification records for all pressure vessels and components of the subsystems that were considered have been reexamined during this MSC review. It was established that all certification requirements were adequately met, that all discrepancies were adequately explained, and that all components were qualified for flight. It should be noted that a comparison of the certification requirements with the expected flight and ground environment was not part of this review.

Apollo J-Missions

Both the CSM and LM systems are being modified to support the extended lunar stay time and lunar orbit experiments for later Apollo missions. The MSC review included the nitrogen bottle being added to the scientific instrument module of the service module for the Pan camera. The other system changes and additions to the LM and CSM for the J-Mission consist of the addition of more pressure vessels and components of the types already installed in the spacecraft and examined during this review. No new pressure vessels or components are planned.

Lunar Module "Lifeboat"

Associated with the Related Systems Review, MSC is also analyzing how the "lifeboat" capability of the LM could be enhanced. The LM, CSM, and PLSS/UPS are being reviewed to determine what minor modifications to the concerned systems and/or changes in procedures should be incorporated. The intent of the changes would be to enhance the ability of the crew to interchange or transfer oxygen, water, electrical power, and lithium hydroxide cannisters between spacecraft and to increase the probability of crew survival following multiple failures in the command module.

DISCUSSION

As a result of the MSC Related Systems Reviews that have been completed and are still in progress, the following observations are offered.

A fracture mechanics analysis was made of all Saturn-Apollo pressure tanks by the Boeing Company for NASA in 1968-1969 (ref. 40). However, most of these tanks were designed without consideration of fracture mechanics. Consequently, at the time of the Boeing analysis, some pertinent data were not available. For example, sustained load and cyclic load flaw growth data were not available for Inconel 718 electron beam welds such as are used in the supercritical oxygen tanks and in the GOX tanks of the LM ascent stage. These data are now being generated in a current program at Boeing, sponsored by NASA. It is also understood that sustained load flaw growth data are not available for a D6aC steel GOX tank in the LM descent stage. Until very recently (ref. 41) sustained load flaw growth data were not available for the cryoformed 301 GOX tanks used in the PLSS and the PAD pack. It is entirely possible that the new data will not change the conclusions derived from the original fracture mechanics analysis; however, it is advisable to reexamine the Boeing analysis of the spacecraft pressure vessels with a view to incorporating the latest information. As an example, particular attention is warranted for the 6Al-4V-Ti tanks containing nitrogen tetroxide, since nitrogen tetroxide is a potentially aggressive environment for titanium. It is recognized that elaborate precautions are presently being taken to control the service conditions of these tanks in such a way that sustained load crack growth should not occur during a mission.

To assure that no unsatisfactory materials are used in oxygen/oxidizer systems in future spacecraft, it is advisable to examine all components and/or elements for compatibility (including dynamic applications) in their media. Where compatibility data at the appropriate service conditions are not available, tests should be conducted.

It appears appropriate to conduct tests with typical hydrogen tank materials in hydrogen, at system operating conditions, to determine if an exothermic reaction can be initiated by electrical fault.

It would be appropriate to expand the MSC investigation to include a review of the manufacturing processes used in the fabrication of critical tanks and components to insure that the processes used are not conducive to inducing failures.

A reevaluation of the filtration, sampling, and analysis of the gases and fluids used is considered appropriate to insure that the requirements for cleanliness and purity in the servicing of spacecraft systems are being satisfied.

It may be advisable to conduct investigations of the compatibility of the nonmetallics in the launch vehicle oxygen and oxidizer systems, as well as spacecraft and launch vehicle GSE (with emphasis on impact sensitivity at operating conditions).

PART D4

SUMMARY

The Design Panel conducted a review and evaluation of the design of those elements of the Apollo spacecraft systems that were implicated as contributing to the Apollo 13 accident. These comprise primarily the oxygen tanks of the service module, the associated valves, plumbing, and electrical systems. In addition, the Panel surveyed other systems within the spacecraft to determine whether their designs contained potential for failures similar to those of the oxygen tank.

During its considerations, the Panel examined the tank in two configurations. The first was in the configuration as defined by the drawings and other controlling documentation. The second configuration was what might be termed the "as flown" condition, that is, containing such variations from standard as may have resulted from unusual events in the history of oxygen tank no. 2. The following were the two most significant such events:

1. The oxygen "shelf drop" incident during spacecraft manufacture.
2. The unorthodox detanking procedure employed at KSC made necessary by inability to detank in the standard manner.

The following observations result from this review:

1. As a pressure vessel, that is, from a structural viewpoint, the tank is adequately designed. The pressure vessel is constructed of a tough material well chosen for this application. The stress analyses and results of the qualification burst test program confirm the ability of the tank to exhibit adequate structural performance in its intended application.

2. From a systems viewpoint, the design of the oxygen tank is unsatisfactory. The design features of the tank system are such that:

- (a) It is difficult to install the internal components of the tank. The design is such that this operation is "blind" and not amenable to visual inspection after completing the installation.

- (b) There is power wiring internal to the tank exposed to supercritical oxygen.

- (c) There is great potential for damage to internal wiring during assembly. There are sharp corners on metal parts in proximity

to the wires; the wiring is routed over rather tortuous paths; the wiring is located in close proximity to rotating components and to the heater elements; and the wiring is free to be flexed by moving fluid during fan operation and/or during filling or emptying of the tank with gaseous or liquid media.

(d) The rating of the thermostats in the heater circuits is not compatible with the voltages that are (and in this instance were for a prolonged period) applied to these circuits at the launch site.

(e) There are combustible materials within the tank, such as Teflon, solder, aluminum, and drilube 822.

3. The combination of combustible materials and potential ignition sources, including the use of unsealed electric motors, constitutes a hazard that can lead to a fire within the tank.

4. The manufacturing tolerances of the Teflon adapters, short Inconel tube, and quantity gage center tube that comprise the tank fill and drain tube are such that extremely loose fit can occur. If these elements were at or near the appropriate dimensional extremes in tank no. 2, it is possible that mechanical shock could cause a disengagement of these parts that could have led to inability to detank. Such might have been caused by the "shelf drop" incident.

5. The nonstandard detanking of oxygen tank no. 2 at KSC probably led to the degradation of the insulation of the internal wiring. The insulation probably became brittle, and flexing of the wire either during or subsequent to the detanking could cause it to break off, exposing the conductor. This would provide a means for creating an electrical short that could initiate combustion of the insulation. The planned all-up test reproducing the detanking should provide data to conclusively verify this.

6. The fuel cell oxygen shutoff solenoid valve has power wiring and combustibles exposed to a 900 psi oxygen environment and is protected by a 10-ampere circuit breaker. The combination of combustibles, potential ignition source, and oxygen within this device constitutes a hazard similar to that prevailing within the oxygen tank.

7. The caution and warning indicators in the CM for the fuel cell reactant shutoff valves use series logic. This logic requires that both the hydrogen and oxygen reactant valves be closed in order that a warning indication may be given. Therefore, it is possible for a fuel cell to be deprived of one of its reactants because of a closed valve and thus suffer irreversible damage without the crew being made aware of this state via the caution and warning indicators.

8. Loss of a main bus deprives some of the talkback indicators of actuating power. In such an eventuality, misinformation as to the state of certain valves may be presented to the crew when valid information as to status of system components is most vital.

9. The logic of the master alarm feature of the caution and warning system is such that preexistence of an operationally expected signal (within a given subsystem) such as "hydrogen pressure low" prevents receipt of a master alarm for a second, and possibly dangerous, condition such as high oxygen pressure.

As a result of these observations, it is the consensus of the Design Panel that the Board should give consideration to including the following among its recommendations.

The internal components of the oxygen tank system should be redesigned. The requirement for the functions performed by these components should be reevaluated carefully. If it is determined that some or all of these components are mandatory for accomplishing the mission, the redesign should be of such nature as to minimize the amount of potentially combustible material within the tank. The installation of any wiring that must be within the tank should be so designed as to preclude direct contact with the oxygen if at all possible. As a minimum, wiring must not be in contact with the oxygen if, under fault conditions, sufficient energy is available to ignite proximate materials. Determination of what constitutes sufficient energy for ignition should be based on data from tests conducted under all conditions that would be encountered in service. It would be preferable that any redesign of the internal components permit assembly of these components into a total subsystem outside the tank. This would permit thorough inspection and test prior to installation within the pressure vessel.

The fuel cell reactant shutoff valve should either be redesigned to eliminate electrical wiring in contact with high-pressure oxygen or a suitable substitute valve be found.

The logic of the caution and warning system should be reviewed with a view towards eliminating lack of a warning indication for a single malfunction that can cause irreparable loss of a mission-critical component. The logic of the master alarm feature of the caution and warning system should also be reviewed with the view towards eliminating the feature that precludes the receipt of a second alarm in the presence of a preexisting alarm from the same system or subsystem. The possibility of providing a redundant power supply to permit proper functioning of talkback type indicators in the event of loss of the main bus normally supplying power to the indicators should also be examined with a view to providing a valid indication to the crew in the event of such a malfunction.

The ability of components to perform their appropriate functions without damage when exposed to shock loading levels in excess of those anticipated to be encountered in flight or in ground handling should be demonstrated by tests. Components found wanting in this respect should be either modified or replaced.

The comprehensive review initiated by the MSC Apollo 13 Investigating Team of all CSM and LM tanks, valves, and associated system elements in which oxygen or oxidizers are stored, controlled, or distributed should be prosecuted vigorously. The acceptability of materials within such components should be established by tests conducted under fluid conditions like those that will be encountered in service both on the ground and in flight. In addition, the review should be expanded to include the manufacturing and assembly procedures employed in the fabrication of those of the previously noted components which are determined to contain hazards.

REFERENCES

1. Anon.: Apollo Operations Handbook, Command and Service Modules. Apollo 13, CSM 109 and Subsequent. Volume 2 - Operational Procedures. SM2A-03-Block II-(2), published under authority of NASA MSC Flight Crew Support Division, Oct. 10, 1969 (Change date: Dec. 15, 1969). (Also available as SD-69-57, vol. 2, North American Rockwell). (Available to NASA and NASA Contractors only).
2. McCrary, T. W.; and Thompson, J. M.: Inconel 718 - Alloy Forgings, for Pressure Vessels: Consumable Electrode, Vacuum Melted. Specification MB0170-026, Revision A, Space and Information Systems Division, North American Aviation, Inc., Mar. 18, 1966.
3. Anon.: Shell - Oxygen Tank, Lower. Drawing 13532-3003, code identification no. 07399, Boulder Division, Beech Aircraft Corp., Nov. 13, 1962.
4. Anon.: Shell -Oxygen Tank, Upper. Drawing 13532-3021, code identification no. 07399, Boulder Division, Beech Aircraft Corp., Nov. 13, 1962.
5. Anon.: Probe Assembly - Oxygen Tank. Drawing 13532-2602, code identification no. 07399, Boulder Division, Beech Aircraft Corp., Sept. 3, 1965.
6. Dulaigh, D. E.: Test Report for Acceptance and Qualification Testing of Inconel Pressure Vessel PV-1 (QT-1). Report no. BR-13955-5, Boulder Division, Beech Aircraft Corp., July 21, 1964.
7. Fuson, T. A.: Test Report for Acceptance and Qualification Testing of Inconel Pressure Vessel PV-2 (QT-2). Report no. BR-13955-6, Boulder Division, Beech Aircraft Corp., July 23, 1964.
8. Dulaigh, D. E.: Test Report for Acceptance and Qualification Testing of Inconel Pressure Vessel PV-3 (QT-3). Report no. BR-13955-7, Boulder Division, Beech Aircraft Corp., Aug. 31, 1964.
9. Dulaigh, D. E.: Test Report for Acceptance and Qualification Testing of Inconel Pressure Vessel PV-4 (QT-4). Report no. BR-13955-8, Boulder Division, Beech Aircraft Corp., Oct. 15, 1964.
10. Anon.: Analytical Report on Proof, Leak, and Burst Testing of Inconel Pressure Vessel PV-1. Report no. BR-13758, Beech Aircraft Corp., June 29, 1964.

11. Anon.: Analytical Report on the Proof, Leak, and Burst Test of Inconel Pressure Vessel PV-2. Report no. BR-13759, Beech Aircraft Corp.
12. Balthazar, R. J.: The Proof, Leak, and Burst Testing of Inconel Pressure Vessel PV-3. Report no. BR-13780, Boulder Division, Beech Aircraft Corp., Aug. 27, 1964. (Available to U.S. Government and Contractors only).
13. SD67-1103, North American Rockwell Corp., Nov. 2, 1967.
14. Kavanaugh, H. C., Jr.: Structural Analysis of the Service Module Fuel Cell Cryogenic Oxygen and Hydrogen Pressure Vessels. MSC Structures Branch Report 68-ES4-1, Oct. 23, 1967.
15. Anon.: Thick Section Fracture Toughness. Final Summary Report, July 1, 1963 - June 30, 1964. ML-TDR-64-236 (Contract AF33 (657) 11461, Proj. 648D), Boeing - North American, Oct. 1964. (Notice - Release only to U.S. Government Agencies is authorized. Other certified requestors shall obtain release approval from Federal Aviation Agency.)
16. Wolf, J.; Brown, W. F., Jr.; Manson, S. S.; Sessler, J. G.; and Shannon, J. L., Jr., eds.: Aerospace Structural Metals Handbook. 1969 Publication (1968 Supplement I, Inc.). AFML-TR-68-115 (formerly ASD-TR-63-741), Mechanical Properties Data Center, Bel-four Stulen, Inc. (Traverse City, Mich.), 1968.
17. Report no. BR-13958-200, Beech Aircraft Corp., Nov. 28, 1966.
18. SD68-466-1, 2, 3, North American Rockwell Corp.
19. Anon.: CSM 105/AV Acoustic and Vibration Engineering Test Requirements, Apollo. SD 67-640 (Contract NAS 9-150), Space Division, North American Rockwell Corp., Jan. 12, 1968.
20. Carnevale, A.: Storage Subsystem - Cryogenic. Specification MC901-0685, Revision C, Space and Information Systems Division, North American Aviation, Inc., Mar. 15, 1967.
21. Anon.: Quarterly Reliability Status Report (U). SID 62-557-13 (Contract NAS 9-150), Space and Information Systems Division, North American Aviation, Inc., Apr. 30, 1965, pp. 3-53 to 3-54.
22. Drawing 13532-1005, Beech Aircraft Corp.
23. Report no. BR-13956, Beech Aircraft Corp., Apr. 16, 1964.

24. Anon.: Storage Subsystems--Cryogenic. Specification no. MC901-0685, North American Rockwell Corp., Mar. 15, 1967.
25. Anon.: Design and Procurement Specification for Stainless Steel Heating Elements. Specification no. BS-14457, Revision A, Beech Aircraft Corp., Dec. 17, 1965.
26. Anon.: Design and Procurement Specification for Thermostats for Cryogenic Application. Specification no. BS-14456, Revision B, Beech Aircraft Corp., Aug. 24, 1967.
27. Anon.: Phase B Life Test, First Mission Simulation, Oxygen Cryogenic Storage Subsystem. Qualification Test Report No. BR-13958-100, Beech Aircraft Corp., Nov. 7, 1966.
28. Anon.: Wiring Diagram--Tank, Storage, Oxygen. Drawing no. BR-13532-2701, Beech Aircraft Corp., Oct. 27, 1965.
29. Anon.: Comparative Analysis of Physical Properties Between Cross-linked Extruded Polyvinylidene Fluoride (Kynar) and Teflon Coated Wires. IDEP 951.16.55.22-62-01, Honeywell, Inc., Sept. 13, 1966.
30. Brown, Robert G.; Holstein, Williams H. Jr.; and Linton, T. Jerry: TFE-FEP Fluorocarbons. Machine Design, Vol. 40, no. 29, Dec. 12, 1968, pp. 54-58.
31. Lucas, W. R.; and Riehl, W. A.: Instrument for Determination of Impact Sensitivity of Materials in Contact with Liquid Oxygen. ASTM Bulletin, no. 244, Feb. 1960, pp. 29-34.
32. Anon.: Tentative Method of Test for Compatibility of Materials with Liquid Oxygen (Impact Sensitivity Threshold Technique). ASTM Designation: D 2512-66 T. In 1969 Book of ASTM Standards with Related Material. Part 18: Petroleum Products - Measurement and Sampling. American Society for Testing and Materials (Philadelphia, Pa.), 1969, pp. 700-715.
33. Key, C. F.: Compatibility of Materials with Liquid Oxygen, IV. NASA TMX-53773, Aug. 23, 1968. (Special Release - Not to be indexed, referenced, or given further distribution without approval of NASA. For internal U.S. Government use only.)
34. Key, C. F.: Compatibility of Materials with Liquid Oxygen, III. NASA TMX-53533, Nov. 3, 1966. (Special Release - Not to be indexed, referenced, or given further distribution without approval of NASA. For internal U.S. Government use only.)

35. Key, C. F.; and Riehl, W. A.: Compatibility of Materials with Liquid Oxygen. NASA TMX-985, Aug. 1964. (Special Release - Not to be indexed, referenced, or given further distribution without approval of NASA. For internal U.S. Government use only.)
36. Key, C. F.: Compatibility of Materials with Liquid Oxygen (U). NASA TMX-53052, May 26, 1964.
37. Perrine, C. H.; and Simpkinson, Scott H.: Compatibility Tests of Materials in the Oxygen Tank. MSC Systems Engineering Division Memo PD/M-215/70, May 19, 1970.
38. Report QTR 5630061, (Report no. EER-5630061 or Qualification Test Report for Part No. 5630061), Parker Aircraft, Mar. 1967.
39. NR Engineering Analysis Report ATR 496026, addendum to CTR 234 96 026, North American Rockwell Corp., July 27, 1967.
40. Shah, R. C.: The Fracture Mechanics Assessment of Apollo Launch Vehicle and Spacecraft Pressure Vessels, Vol. 1. Report D2-114248, the Boeing Company, Nov. 1968.
41. Schwartzberg, F. R.; Keys, R. D.; and Kiefer, T. F.: Interim Report on Cryogenic Alloy Screening. NASA Contract NAS 3-11203 (Lewis contract no.), Martin Marietta Corp., 1970.

APPENDIX E
REPORT OF PROJECT MANAGEMENT PANEL



CONTENTS

Part		Page
	APPENDIX E - REPORT OF PROJECT MANAGEMENT PANEL	
E1	<u>TASK ASSIGNMENT</u>	E-1
E2	<u>PANEL MEMBERSHIP</u>	E-3
E3	<u>SUMMARY</u>	E-5
	INTRODUCTION	E-5
	General Technical Capability	E-5
	Division of Responsibilities	E-6
	Cryogenic Oxygen Tank Design	E-6
	Configuration Control Procedures	E-7
	Oxygen Tank Handling Incident at Downey	E-7
	KSC Detanking Problems	E-7
	Materials Compatibility	E-10
	Security Program	E-11
	Safety and Reliability and Quality Assurance	E-11
	Failure Reporting	E-12
E4	<u>MANAGEMENT ORGANIZATION</u>	E-13
	BACKGROUND AND PERSPECTIVE	E-13
	NASA - APOLLO MANAGEMENT ORGANIZATION	E-14
	NASA Headquarters Organization	E-15
	Office of Manned Space Flight Organization	E-15
	Manned Spacecraft Center (MSC)	E-18

Part		Page
	Marshall Space Flight Center (MSFC)	E-18
	Kennedy Space Center (KSC)	E-18
	CONTRACTOR ORGANIZATIONS	E-21
	North American Rockwell (NR)	E-21
	North American Launch Operations Space Division (KSC)	E-26
	Beech Aircraft Corporation	E-26
E5	<u>RESPONSIBILITIES AND OPERATING RELATIONSHIPS</u> . . .	E-31
	NASA ADMINISTRATOR	E-31
	ASSOCIATE ADMINISTRATOR FOR MANNED SPACE FLIGHT	E-31
	Manned Space Flight Management Council	E-32
	Science and Technology Advisory Committee	E-32
	Manned Space Flight Experiments Board	E-32
	APOLLO PROGRAM DIRECTOR	E-32
	Test Directorate	E-33
	Operations Directorate	E-33
	Systems Engineering Directorate	E-33
	Program Control Directorate	E-33
	Reliability and Quality Assurance (R&QA) Directorate	E-35
	Support Contractors	E-35
	MSC APOLLO SPACECRAFT PROGRAM OFFICE (ASPO)	E-35

Part		Page
	Assistant Program Manager for Flight Safety	E-36
	Systems Engineering Division	E-36
	CSM Project Engineering Division	E-38
	Resident Apollo Spacecraft Program Offices (RASPO)	E-38
	MSC RELIABILITY AND QUALITY ASSURANCE (R&QA) OFFICE	E-39
	MSC SAFETY OFFICE	E-39
	MSC ENGINEERING AND DEVELOPMENT DIRECTORATE	E-40
	KSC APOLLO PROGRAM MANAGER	E-41
	KSC DIRECTOR OF LAUNCH OPERATIONS	E-41
	INTER-CENTER RELATIONSHIPS	E-41
	PROGRAM MANAGEMENT CONTINUITY	E-60
E6	<u>APOLLO SPACECRAFT PROGRAM MANAGEMENT SYSTEMS</u> . . .	E-63
	DESIGN REVIEWS	E-63
	Preliminary Design Review	E-64
	Critical Design Review	E-64
	CONFIGURATION MANAGEMENT	E-64
	READINESS REVIEWS	E-67
	Customer Acceptance Readiness Reviews	E-67
	Flight Readiness Reviews	E-68
	Launch Minus 2-Day Review	E-69
	LAUNCH CHECKOUT PROCEDURES	E-69

Part		Page
E7	<u>OXYGEN TANK MANAGEMENT REVIEW</u>	E-73
	GENERAL TANK HISTORY	E-73
	Tank Vacuum and Heat Leak Problems	E-75
	Fan Motors	E-75
	Vac-ion Pump and Electromagnetic Interface (EMI) Problems	E-76
	Heater Failures	E-76
	CHRONOLOGY OF APOLLO 13 OXYGEN TANK	E-77
	Handling Incident	E-78
	Detanking Incident	E-80
E8	<u>OXYGEN TANK MATERIAL SELECTION</u>	E-85
	FUNCTIONAL DESCRIPTION	E-85
	Material Property Requirements	E-85
	Materials Listing	E-87
E9	<u>SAFETY AND RELIABILITY AND QUALITY</u> <u>ASSURANCE(R&QA)</u>	E-89
	INTRODUCTION AND ORGANIZATION	E-89
	General	E-89
	NASA Headquarters	E-89
	Manned Spacecraft Center	E-92
	John F. Kennedy Space Center	E-101
	North American Rockwell Corporation - Space Division	E-102
	Beech Aircraft Corporation	E-105

Part		Page
	SAFETY AND R&QA AUDITS	E-106
	MSC SAFETY/R&QA PARTICIPATION	E-107
	Phase III CARR for CSM 109	E-107
	FRR R&QA Summary	E-108
	Weekly Safety/R&QA Report	E-109
	Apollo 13 Mission Real-Time Activities	E-110
	CONCLUSION	E-113
E10	<u>SECURITY</u>	E-115
	<u>REFERENCES</u>	E-116

This page left blank intentionally.

PART E1

TASK ASSIGNMENT

The Project Management Panel was established by the Apollo 13 Review Board to review those management systems in the Apollo Program which were pertinent to the Apollo 13 accident. In effect, this task required the review of all appropriate design, manufacturing, and test procedures covering vehicle systems which may have failed in flight, including the means by which various organizations coordinated their individual efforts in the total process. The Panel took special care to evaluate carefully the safety management system which was applicable to Apollo 13.

Principal questions addressed by the Management Panel focused on the organization, procedures, and systems used to monitor and control CSM design, manufacturing, test, assembly, and final certifications of flight equipment, and particularly of the cryogenic oxygen system used in the service module electric power system and environmental control system.

This page left blank intentionally.

PART E2

PANEL MEMBERSHIP

Panel 4 was chaired by Mr. E. C. Kilgore, Deputy Chief, Engineering and Technical Services, Langley Research Center. The Board Monitor was Mr. Milton Klein, Manager, AEC-NASA Space Nuclear Propulsion Office. Panel members were:

Mr. R. D. Ginter, Director, Special Program Office
Office of Advanced Research and Technology (OART)
NASA, Headquarters, Washington, D.C.

Mr. Merrill Mead, Chief, Programs and Resources Office
Ames Research Center
Moffett Field, California

Mr. James B. Whitten, Asst. Chief, Aeronautical and Space
Mechanics Division
Langley Research Center
Hampton, Virginia

In addition, Mr. R. C. Puffer of MSC Security assisted the Panel by preparing the section of the report on Security.

This page left blank intentionally.

PART E3

SUMMARY

INTRODUCTION

The Management Panel carried out a detailed in-depth review of the Apollo Spacecraft Program Office organizational structure and the management system used to control both command and service module (CSM) hardware development and decision-making processes. The review examined the system for Apollo and focused attention on the specific cryogenic oxygen tank directly involved in the Apollo 13 accident. Key management personnel at the Manned Spacecraft Center (MSC), the Kennedy Space Center (KSC), and Apollo contractors and subcontractors were interviewed. These interviews were specifically aimed at understanding what decisions were made regarding the oxygen tank system for Apollo 13, who participated in these decisions, what information was available from the management system, how effectively the organizational elements functioned in reviewing, communicating, and carrying out assigned responsibilities, and whether management system changes are required in view of the oxygen tank accident. Records of the oxygen tank reviews, discrepancy reports, failure reports, and procedures were examined to determine if the review systems and configuration control system functioned as they were intended. Separate reviews were made of the Security, Safety, and Reliability and Quality Assurance (R&QA) management systems to determine effectiveness.

Visits were made to the CSM prime contractor, North American Rockwell (NR), Downey, California, and to the oxygen tank subcontractor, Beech Aircraft, Boulder, Colorado, during which discussions were held with key design, test, and manufacturing personnel. Reliability inspection, safety, configuration-control and process-control procedures and systems were reviewed and examined in detail. KSC operations were reviewed and discussions were held with key test and launch operations personnel regarding their responsibilities, procedures, and controls. Similar discussions were held with MSC Apollo CSM key management and engineering personnel. Throughout its analysis, the Panel devoted particular attention to the history of the Apollo 13 cryogenic oxygen tank no. 2 including design and manufacturing waivers, discrepancies, and anomalies and how these were handled by the Apollo management team.

General Technical Capability

The Panel found key Apollo personnel to be technically capable and dedicated to producing a reliable and safe spacecraft system. Although there have been cutbacks in the total number of Apollo personnel, the

morale of the remaining Apollo team is considered by officials interviewed to be high. Reductions in personnel complements as the flight rate has been reduced have not detrimentally impacted the experience level within the Program to this point. Moreover, critical flight and ground system personnel requirements have been carefully reviewed by project officials to insure adequate manning. During the Apollo Program, there have been changes in key management personnel. The Panel found that attention was given to maintaining continuity of experience by essentially promoting from within the Apollo Program. Some technicians with considerable CSM experience have been replaced at NR-Downey by technicians from other programs with more seniority, but no CSM experience. This was recognized as a potential problem and an intensified training program was instituted. Continued surveillance of the contractor technician experience level and capability is necessary.

Division of Responsibilities

The Apollo spacecraft organization involves a large number of contractor, subcontractor, and Government organizations. It was found that these organizations understand their individual responsibilities and that necessary coordination processes were in effect. This process provides a system of checks and cross-checks to assure that detailed consideration and attention is given to problems by the right organizations prior to final flight commitment.

Cryogenic Oxygen Tank Design

Apollo oxygen tank no. 2 was designed in the 1962-1963 time period by Beech prior to the formation of the formal design review and subsystem manager systems which now exist at MSC. During the design phase, there was limited participation by MSC technical personnel in the early design. The primary emphasis at this time by both the prime contractor and MSC was on the thermodynamic performance of the oxygen system. The tank did receive informal design reviews primarily by NR and Beech personnel. Even though these reviews were made, it was found that the final design resulted in a complex assembly procedure with a wiring cluster which cannot be inspected after assembly in the tank. However, the complexity of the assembly and the inability to inspect the tank interior components after assembly was recognized by Government, NR, and Beech personnel. Consequently, a detailed step-by-step manufacturing and assembly procedure was established and carried out with checklist-type Beech inspections, supplemented by NR and Government inspections at defined critical points. A First Article Configuration Inspection (FACI) was held on the oxygen tank in 1966 which was jointly signed off by MSC and contractor subsystem managers. No subsequent formal design reviews were held.

A thermostatic switch (thermal switch) was incorporated into the Block I oxygen tank heaters to avoid overheating while using 28 V dc spacecraft power. After receipt of the Block II oxygen tank specifications from NR in February 1965, which required the tank heater to operate not only on 28 V dc spacecraft power but also with 65 V dc GSE for rapid tank pressurization during launch operations at KSC, Beech did not require their Block I thermal switch supplier to make a change in switch rating. NR never subsequently reviewed the heater assembly to assure compatibility between the GSE and the thermal switch. This resulted in NR, MSC, and KSC personnel subsequently assuming that the tank was protected from overheating while using the 65 V dc power supply.

Configuration Control Procedures

The Panel found that a strict and rigorous management system exists on the CSM for configuration control, problem reporting, customer acceptance readiness reviews, and flight readiness reviews. Both contractors and Government CSM organizations participate in this system. R&QA organizations independently monitor, record, and report all problems and approved resolutions. Examination of documentation, such as failure reports, discrepancy reports, and waivers generated in the management system and applicable to the Apollo 13 oxygen tank, demonstrated to the Panel that the management system was being followed closely. Closeouts were being accomplished with authorized approvals.

Oxygen Tank Handling Incident at Downey

In the case of the Apollo 13 oxygen tank handling incident at NR-Downey, the Panel found that a Discrepancy Report was written and functional tests were made by NR Engineering. The incident was judged to have caused no tank damage by the contractor's systems engineers and representatives of the RASPO at Downey. Also, the oxygen tank subsystems manager at MSC was made aware of the incident. Subsequent functional tests were successfully passed. The Discrepancy Report was closed out in the authorized manner. Although the handling incident was not reported to the Apollo Spacecraft Program Manager, it should be noted that such reporting of Discrepancy Report closeouts is not required in all cases. Once this incident was closed out in the manner prescribed by the Apollo management control system, it was not reopened as a possible factor relating to the later detanking problem at KSC.

KSC Detanking Problems

In the case of the detanking problem at KSC, it was found that all authorized Discrepancy Reports were filed and signed off. The

change from normal detanking procedures was made to use the tank heaters and fans in an attempt to boil off the liquid oxygen in the tank. This was unsuccessful and the normal procedure was further altered by use of a pressure pulsing method. These changes to the test procedures were made by the KSC Systems Engineer and NR Systems Engineer who were on station. They obtained concurrence of the NR lead systems engineer at KSC. This is in agreement with the present requirements for test procedural changes. After the pressure pulsing method was used to detank oxygen tank no. 2, the problem received further attention, including additional analyses and test. The Apollo team problem-solving effort that resulted was led by the MSC Apollo Spacecraft Program Manager and the KSC Director of Launch Operations. NR and Beech personnel were also involved. The MSC Apollo Spacecraft Program Office formulated a checklist of analyses to be made and questions to be answered prior to making the flight decision on the tank.

This included:

1. Details and procedures for normal detanking at Beech and KSC.
2. Details of abnormal detanking at KSC on March 27 and 28.
3. Hazards resulting from a possible loose fill tube in the oxygen tank.
4. Can the tank be X-rayed at KSC?
5. Could loose tolerances on the fill tube cause detanking problem?
6. Should a blowdown and fill test be made on the tank?
7. Disassemble an oxygen tank on Service Module 2 TV-1 and examine components.

A detailed analysis, including possible failure modes, was made at Beech. Tests were run which indicated that even in the event of a loose metal fill tube (which was concluded to be the most likely cause of the detanking problem), a resultant electrical short would provide only 7 millijoules of energy and it was judged that this energy level could cause no damage except loss of the quantity gage indication. All of the checklist requirements were met by test or analysis prior to making the decision to fly without a change in the oxygen tank. It was jointly concluded by the Beech Apollo Program Manager, the NR CSM Program Manager, the KSC Director of Launch Operations, and the MSC Apollo Spacecraft Program Office (ASPO) Manager that the tank was flightworthy. Further examination of this event since the Apollo 13 accident, however,

has revealed that incomplete and, in some cases, incorrect information was used in the decision process. This included:

1. Neither the KSC Launch Operations Director nor the MSC ASPO Manager knew of the previous tank handling incident at NR-Downey and neither knew that the oxygen tank internal heaters were on for 8 consecutive hours during detanking at KSC. Key personnel at NR-Downey knew of both events. No personnel at MSC, KSC, or NR knew that the tank heater thermal switches would not protect the tank from overheating.

2. A portion of the normal detanking process at Beech is similar to the normal detanking process at KSC. The KSC Launch Operations Director and MSC ASPO Manager were mistakenly informed that they were different. (If they had known of the similarity in detanking processes, they possibly would have concluded that some change took place in the tank between Beech and MSC.)

3. The KSC Launch Operations Director, the MSC ASPO Manager, and key personnel at Downey mistakenly understood that the oxygen tank on previous test Service Module 2 TV-1 had similar detanking problems which led to the decision to disassemble the 2 TV-1 tank and examine the components. That examination was interpreted as evidence that a loose-fitting metal fill tube probably was causing the detanking difficulty. Further examination has revealed, however, that 2 TV-1 oxygen tank probably detanked normally.

Although none of the principals in making the oxygen tank decision (NR, MSC, KSC) can say with certainty that the availability of information in 1, 2, and 3, above would have altered their decision, each concurs that the availability of such information could have altered their decisions.

On the basis of its review, the Project Management Panel feels the following observations to be pertinent:

1. Launch operations personnel did not fully understand the oxygen tank internal components or fully appreciate the possible effect of changed detanking procedures on the reliability of such internal components.

2. The hazard associated with the long heater cycle was not given consideration in the decision to fly this tank.

3. Problem solving during launch operations utilized telephone conferences among knowledgeable parties, but without subsequent written verification, which would have permitted more deliberate consideration and review.

4. Deviations from test procedures during tests at KSC were made in accordance with the established approval process. This does not require prior approval or concurrence of NR-Downey or MSC subsystem specialists.

5. It was found that insufficient consideration was given to the tank internal details such as sharp edges, internal wiring, and heater thermal switch ratings during the design reviews.

6. An historical record of the oxygen tank existed in the management system files. However, it was not referred to in making the flight decision.

7. Dependence upon memory of personnel led to erroneous data being reported to higher management levels.

8. Key Apollo management personnel made several suggestions during the Panel interviews:

(a) Provide total background history on subsystems which have problems or anomalies during launch operations.

(b) Launch operations personnel need more knowledge of the internal details of subsystems.

(c) NR (Downey) and MSC Subsystem Managers should review KSC test procedures and subsequent procedure changes.

(d) Verification of data is needed in problem solving.

(e) Followup documentation of information exchanged during telephone conferences on key problems is recommended.

Materials Compatibility

The compatibility of oxygen tank materials with oxygen received consideration in the original design. Beech reviewed and selected the tank materials in accordance with the published material knowledge that existed in the 1962-1963 time period. No data on hot-wire tests or ignition tests were available to Beech at that time. Beech ran special tests on the fan and motor assembly which was tested at 1000 psia in oxygen gas at 300° F. The motor passed this test with no evidence of

ignition. Some attention was paid in the assembly procedures to avoid pulling wires over threads or sharp corners and to provide protective sleeving. However, most sharp corners were not eliminated and as was previously mentioned, the tank design necessitated a blind assembly with no way for subsequent inspection for damage. After the original design, Beech was not requested by NR to make any further materials compatibility study or tests. In April 1969, NR was directed by MSC to review the nonmetallic materials in the cryogenic oxygen subsystem and document them in accordance with the COMAT (Characteristics of Materials System). All nonmetallic materials in the oxygen tank were evaluated and documented by NR. All nonmetallic materials met the requirements of the materials control program. These materials criteria were specifically formulated for the lunar module and command module, where non-propagation of fire was a requirement even if a fire started.

These COMAT requirements do not adequately cover the 900 psi cryogenic oxygen tank. No electrical ignition testing of any materials was made for the oxygen tank. NR reviewed the service module systems to provide electrical circuit protection such as breakers and fuses in 1967 in an effort to avoid electrical fires in case of shorts.

Security Program

During its review, the Panel also investigated the physical security at Beech, NR-Downey, and KSC for adequacy during the times the Apollo 13 oxygen tank was in custody at these locations. The security program at each location was found to be satisfactory and adequate to provide the physical protection of the oxygen tanks. A determination was made as a result of the survey that no evidence was discovered that the failure of the oxygen tanks on Apollo 13 was the result of any willful, deliberate, or mischievous act on the part of an individual at the facilities surveyed.

Safety and Reliability and Quality Assurance

A detailed management review was made of both the Safety and R&QA organizations as applicable to the Apollo CSM. Safety Offices at NASA Headquarters Office of Manned Space Flight, MSC, and KSC have safety responsibilities regarding Apollo which are clearly established and implemented by both Government and support contractor personnel. Safety audits by NASA Headquarters teams and participation by MSC and KSC personnel in panels, boards, and program reviews demonstrates continuing organizational attention to safety. Safety studies are being made to identify hazards associated with the Apollo spacecraft during ground tests and for each manned mission. NR-Downey has a safety organization

with specific responsibilities for the Apollo CSM. The NR safety function is integrated into the Engineering, Manufacturing, and Test Operations with its objectives to eliminate or control risks to personnel and equipment throughout the manufacture, checkout, and flight missions of the Apollo CSM. Even though the NR safety effort, as written in their Safety Plan, is fragmented over several organizational units, it apparently is working effectively. In all cases, the safety organizations report to a sufficiently high organizational level to provide them a desirable independence of safety surveillance.

Failure Reporting

The Panel found that the Apollo Reliability and Quality Assurance organizations at MSC, KSC, NR, and Beech have an effective independent failure-reporting and failure-correction and tracking system. Documentation from this system was observed to be both rapid and accurate. The Reliability Group provides special studies such as Failure Modes and Effects Analysis (FMEA), Suspect Flight Anomalies Report, and configuration change tracking. In the case of the Apollo 13 oxygen tank, a Single Point Failure Summary was made in 1968. Among the failure modes considered was fire in the CSM external to the oxygen tanks which might lead to the loss of them. This was considered an acceptable risk because of control of ignition sources and low probability of occurrence. Rupture of the oxygen tanks was also considered and accepted due to the redundancy of the oxygen supply and low likelihood of failure occurrence. For Apollo 13, as for previous missions, a System Safety Assessment was made on February 19, 1970, as an additional review from previous missions, and it was concluded that there were no open safety items to constrain the Apollo 13 flight.

PART E⁴

MANAGEMENT ORGANIZATION

Relating organizational and management structures to an event of the kind now under consideration is particularly difficult inasmuch as the time period of importance includes the entire history of the Program, in this case some 9 years, during which these structures have undergone many significant changes. With this in mind, the approach adopted for this study was (1) to examine and document what exists today, (2) to trace the history of events that might have had a direct bearing on the failure, (3) to examine the management implications of those specific events, and (4) to try and assess whether those implications are still pertinent to management as it exists today and whether, therefore, corrective measures of any kind are indicated. To accomplish even this limited objective has required an early focusing of attention on just those organizations and functions directly involved, or potentially involved, in the events under consideration. Thus, following a brief description of the overall organizational and management relationships applicable to the Program as a whole, this report concentrates on those organizations responsible for the particular elements of the Apollo spacecraft in which the failure occurred.

BACKGROUND AND PERSPECTIVE

The Apollo Program has represented the largest single research and development program ever undertaken by the United States Government; at its peak (in 1966) it involved about 300,000 persons. The Government-industry team responsible for the Program has included 25 prime contractors and more than 4,000 subcontractors and vendors.

In its simplest terms, the Apollo Program has two major objectives: (1) to develop a vehicle capable of landing men on the surface of the Moon and returning them safely to the surface of the Earth, and (2) to operate that vehicle in an initial series of manned lunar landing missions. These two objectives have, in a gross sense, dictated the major division of responsibilities among NASA organizations in the management of the Apollo Program. With overall responsibility vested in the NASA Headquarters organization, responsibility for producing the vehicle was assigned to two NASA field installations:

1. For the spacecraft, to the Manned Spacecraft Center, Houston, Texas.
2. For the launch vehicle, to the Marshall Space Flight Center, Huntsville, Alabama.

The responsibility for operating the vehicle in the series of flight missions which constituted the second objective was also assigned to two field installations:

1. For launching the space vehicle, to the Kennedy Space Center, Cape Kennedy, Florida.
2. For all postlaunch operations, to the Manned Spacecraft Center, Houston, Texas.

These two major objectives also serve to classify the two major time periods into which the 9-year history of the Program can be divided. Thus, the first 7 years, from 1961 to 1968, constituted the development stage of the Program in which all components of the space vehicle, supporting equipment, and operational facilities were designed, developed, manufactured and tested; the last 2 years, from 1968 to the present, have constituted the beginning of the "operations" stage of the Program, with two successful manned lunar landing missions already achieved. The significance of distinguishing between these two periods of time lies in the inevitable shift of emphasis that accompanied the transition between the two from engineering problems to operational problems.

NASA - APOLLO MANAGEMENT ORGANIZATION

Two classical approaches to project management were available to NASA when the Apollo Program began in 1961. The first approach, often used by Government and the aircraft industry in the early years of aircraft development, would place in a single organization and under the total control of the project manager all of the skills and specialities required to manage the project. Thus, the project organization would provide for itself all the support necessary in engineering, procurement, program control, financial management, reliability and quality assurance, etc., and would operate virtually independently of the institutional organization of which it was a part. The second approach, which was rapidly gaining acceptance during the 1940's and 1950's, was the so-called "matrix" concept in which skeletal project management organizations were superimposed on an institutional organization containing elements and subelements in all of the specialities needed by the projects. Thus the institutional organization would provide the basic capabilities required by the projects in engineering, procurement, program control, etc., and the project managers would draw upon those as required. The advantages of this approach for multi-project organizations are apparent. Costly duplication of support activities is minimized, the overall efficiency of manpower utilization is maximized, and the quality of support provided is enhanced by consolidation.

NASA adopted the matrix approach to project management for the Apollo Program. In NASA Headquarters, and in each of the three principal NASA field centers involved, Apollo Program Offices were established from which virtually all of the direction for conduct of the Program has emanated. At each location, however, these Program Offices are essentially management organizations and depend heavily on the line elements of the host institution's organization for support. Continuity in lines of authority between the Apollo Program Director in Headquarters and the Apollo Program organization in the field has been assured through the delegation by each Center Director to his Apollo Program Manager of full authority for conduct of that Center's part of the Program. Thus, for purposes of program direction and authority, there exists throughout the Agency a single pyramidal management structure cutting across institutional lines and tying together all elements of the Apollo Program organization. This relationship is illustrated in figure E4-1.

The organizations of the principal NASA institutions involved in the Apollo Program are illustrated in figures E4-2 through E4-6, in which the locations of offices with primary responsibility for Apollo are indicated by heavy lines.

NASA Headquarters Organization

The Associate Administrator for Manned Space Flight, who heads the Office of Manned Space Flight, is the Administrator's executive agent for the general management of all manned space flight programs. His authority flows directly from the Administrator and is broad, covering all aspects of all manned space flight programs. He also exercises institutional line authority over the three manned space flight field centers which report directly to him.

Office of Manned Space Flight Organization

Figure E4-2 shows the organizational structure within the Headquarters Office of Manned Space Flight. The Associate Administrator for Manned Space Flight has assigned the responsibility for management of all aspects of the Apollo Program to the Apollo Program Director, and has delegated to him full authority to carry out that responsibility. The Apollo Program Director is the highest Agency official whose responsibility is exclusively for the Apollo Program. There are counterpart Program Directors for other manned space flight programs with similar responsibilities to their own programs, and there are a number of functional offices which, consistent with the matrix management concept, provide support to all on-going programs. Shown also in figure E4-2 are the direct lines of program authority between the Apollo Program Director and his subordinate program managers in the three field centers.

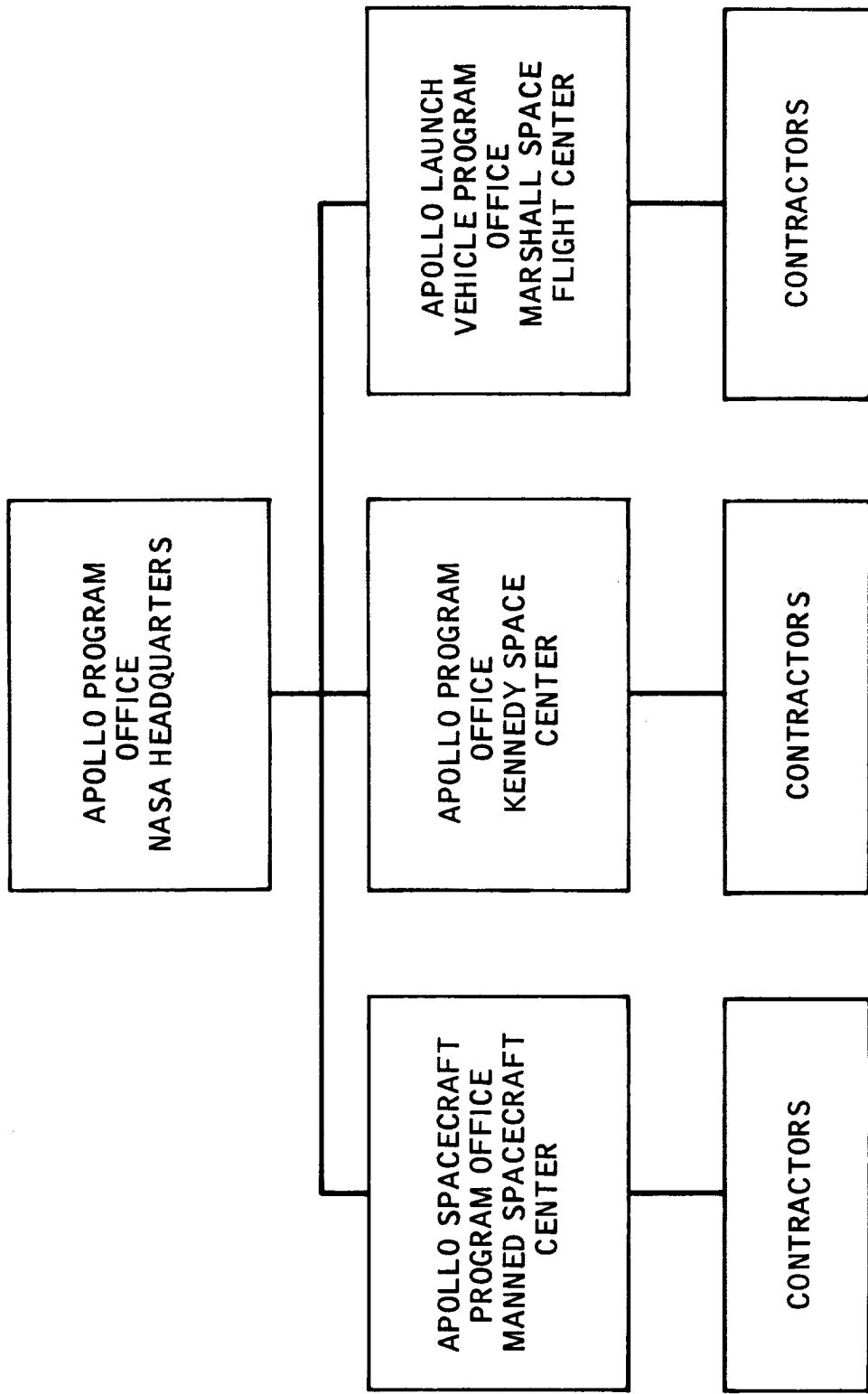

Figure E4-1.- NASA Apollo Program organization.

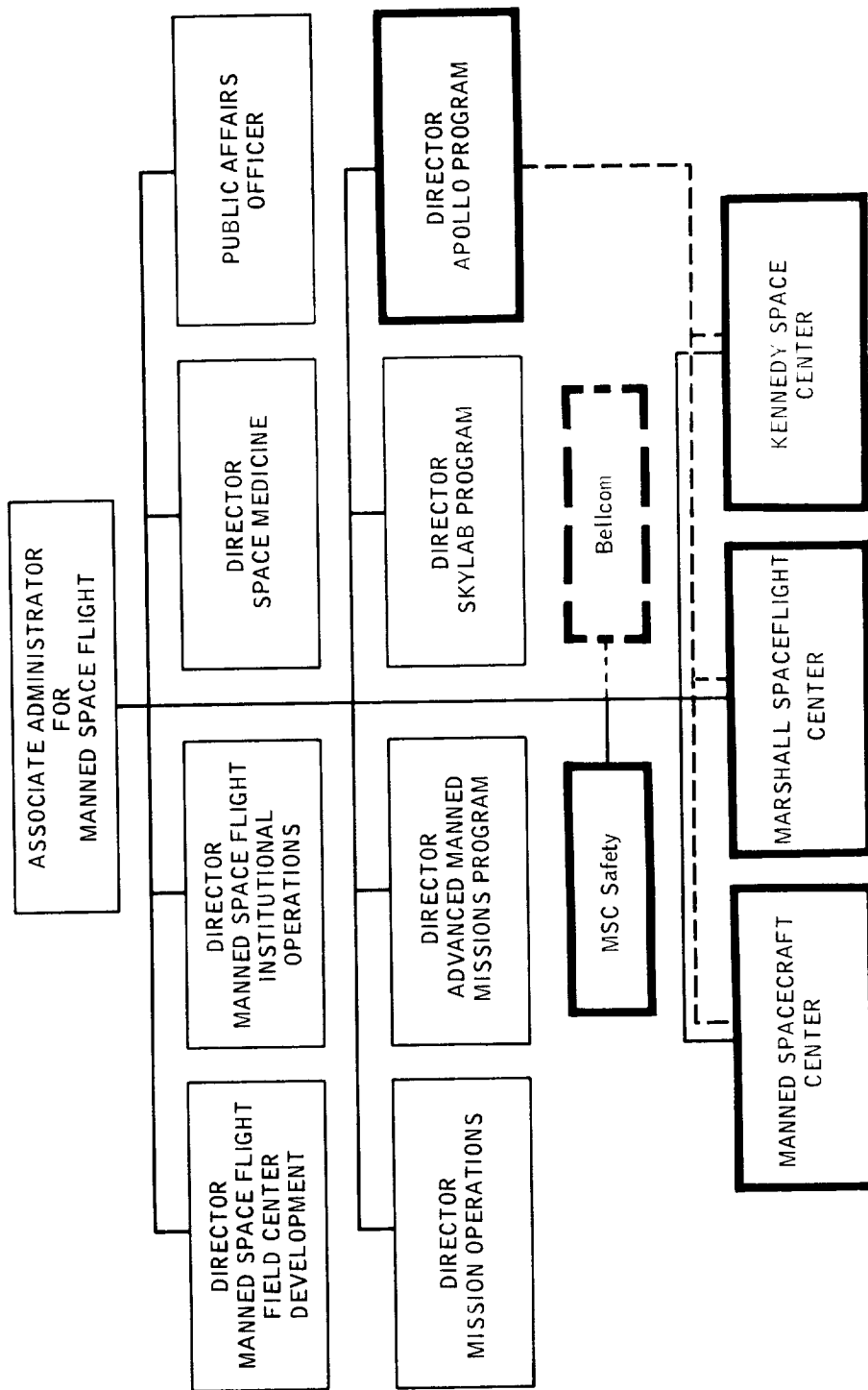

Figure E4-2.- Office of Manned Space Flight organization.

Manned Spacecraft Center (MSC)

The organization of the Manned Spacecraft Center is shown in figure E4-3. The permanent functional organizations are represented by the five technical directorates (Engineering and Development, Science and Applications, Medical Research and Operations, Flight Crew Operations, and Flight Operations) and the institutional Directorates and Staff Offices (e.g., Administration, Program Control and Contracts, Public Affairs, Legal, etc.). The program management organizations presently include the Apollo Spacecraft, Skylab, and Space Shuttle Program Offices, and the Advanced Missions Program Office, which is responsible for studies and planning potentially leading to new flight programs.

Responsibility for managing all aspects of the Apollo Program assigned to the Center is vested in the Manager of the Apollo Spacecraft Program Office (ASPO). Under the matrix-management concept, a relatively small percentage of the Center's staff directly employed in the Apollo Program reports to him organizationally. Virtually all of the Apollo tasks done in-house at MSC (component testing, instrumentation development, flightcrew training, operations planning, etc.) are performed by the Center's line organizations (the functional Directorates) under the overall direction and coordination of the ASPO Manager.

Marshall Space Flight Center (MSFC)

This Center is responsible for the development, manufacture, and testing of the launch vehicles used in the Apollo Program. The organization of the Center is shown in figure E4-4. As at MSC, this Center employs the matrix-management concept in which the basic organization, represented by the Program Development, Science and Engineering, and Administration and Technical Services Directorates, is functional and the program-management organization, represented by the Program Management Directorate, is made up of program offices for individual launch vehicles or stages.

Although the Saturn Program Office represents the Apollo Launch Vehicle Program Office for purposes of full-time management, the Director of Program Management has been designated the Apollo Launch Vehicle Program Manager. He manages and directs all aspects of the Apollo Program assigned to MSFC, drawing on technical support from the Science and Engineering Directorates.

Kennedy Space Center (KSC)

The KSC responsibility in the Apollo Program includes the assembly, checkout, and launch of the space vehicle.

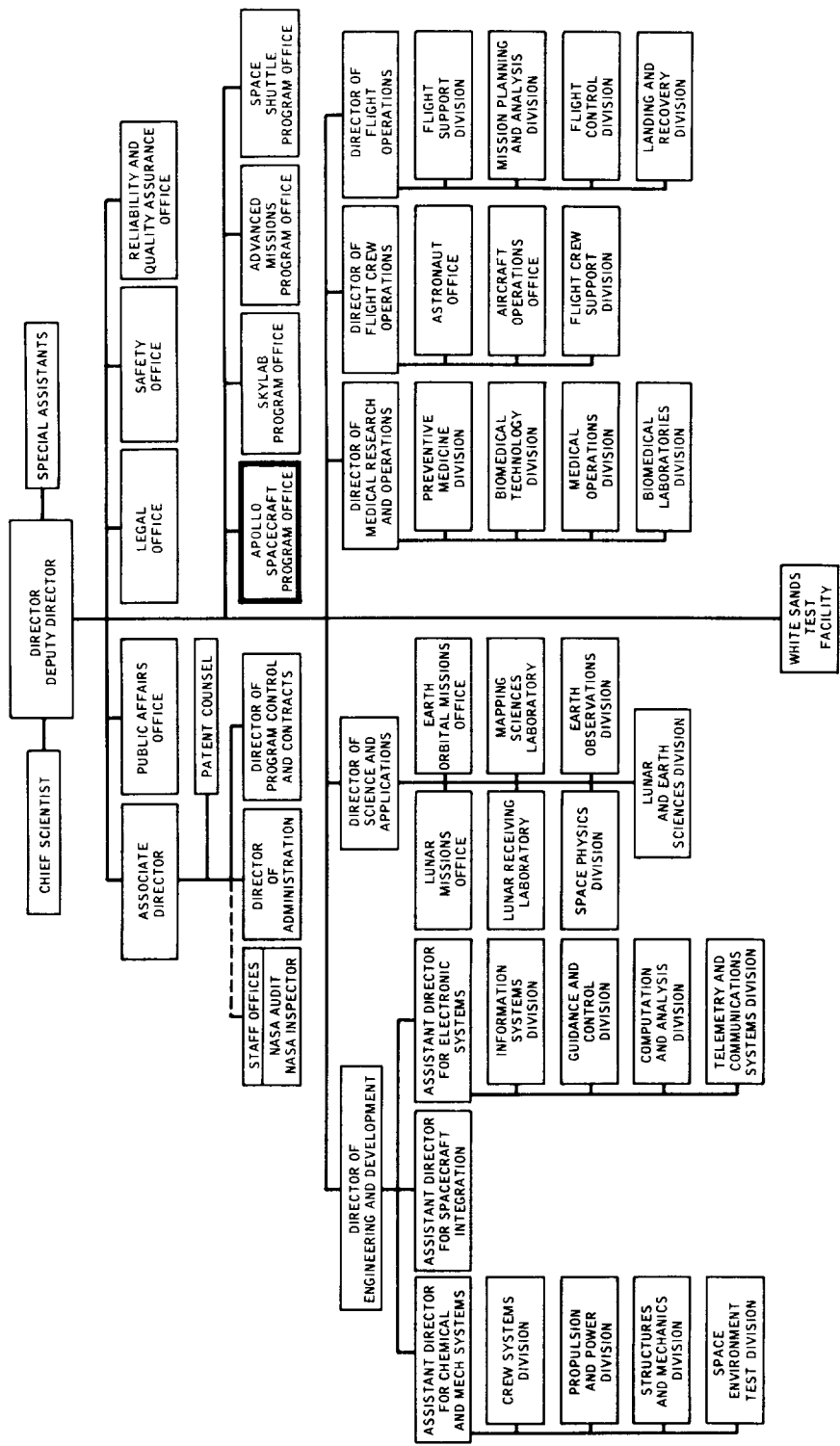

Figure E4-3.- Manned Spacecraft Center organization.

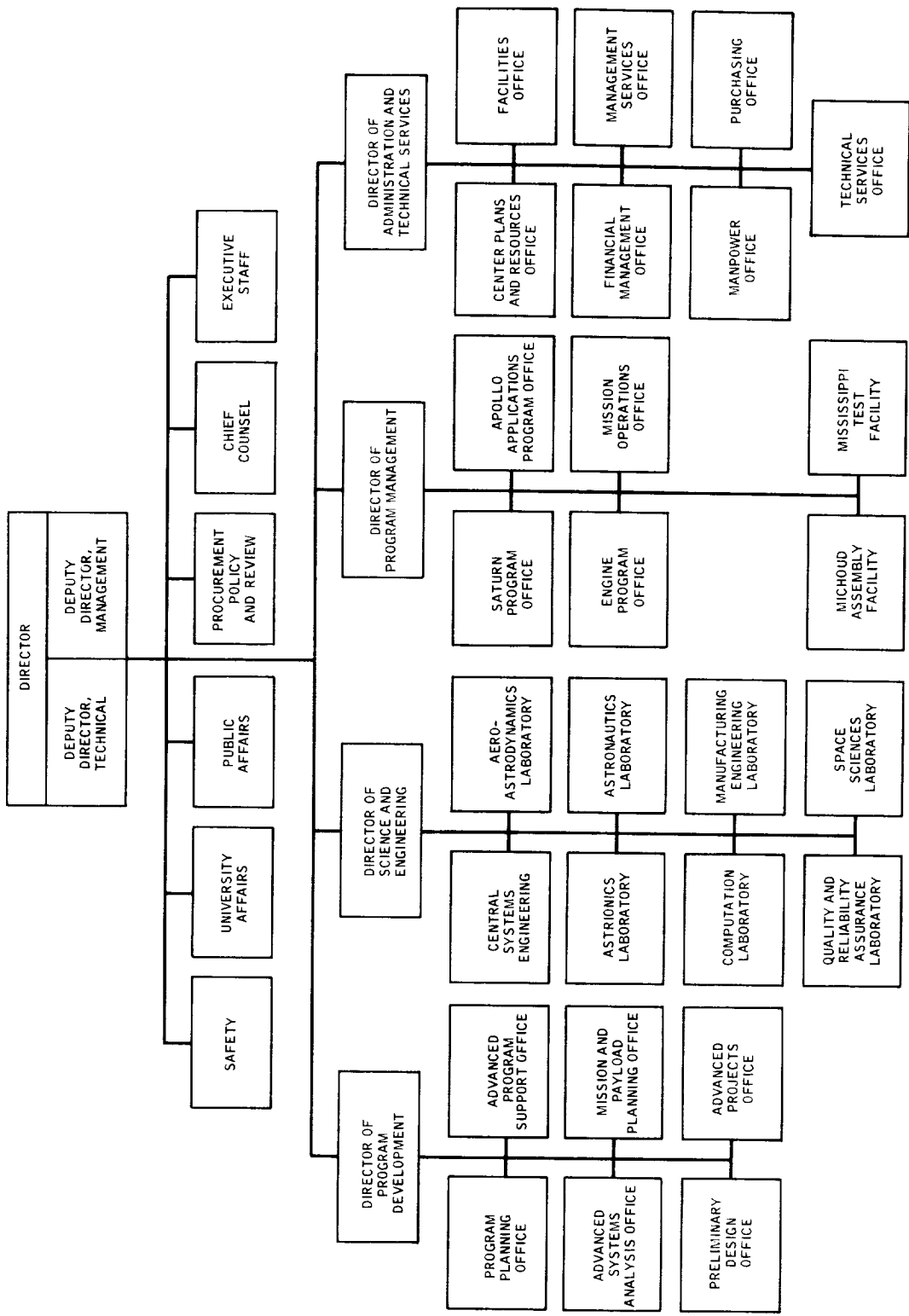

Figure E4-4.- Marshall Space Flight Center organization.

The organization of the Center is shown in figure E4-5. Again the basic organization is functional, consisting of those major operational activities necessary to the launch of all space vehicles. The program-management organization is similar to that at MSC and is made up of an individual program office for each active flight program. Overall responsibility for managing all aspects of the preparation, checkout, and launch of the Apollo space vehicles is assigned to the Manager of the Apollo Program Office (APO). All functional organizations at the Center participate in those activities under the overall direction of the APO Manager. Direct responsibility for launch and checkout is delegated to the Director of Launch Operations.

CONTRACTOR ORGANIZATIONS

The oxygen tank in which the failure occurred was a component of the cryogenic gas storage subsystem (CGSS), which serves both the electrical power system (EPS) and the environmental control system (ECS) of the spacecraft service module (SM). The contractors and contractual relationships involved in the manufacture of the tank are illustrated in figure E4-6. North American Rockwell (formerly North American Aviation), prime contractor for the command and service modules (CSM), subcontracted with Beech Aircraft Corporation for manufacture of the CGSS. Beech, in turn, purchased certain parts for the subsystem from the three vendors shown: the oxygen pressure vessel (inner tank) from Airite Products Division of the Electrada Corporation; the oxygen quantity and temperature sensor probe from Simmonds Precision Products, Inc.; and the fan motors from Globe Industries, Inc. Pertinent organization charts for North American Rockwell and Beech Aircraft are shown in figures E4-7 through E4-11. The organizations of the vendor companies were not considered pertinent and are not shown.

North American Rockwell (NR)

The Apollo CSM contract is held by the Space Division of North American Rockwell and the organization of that Division is shown in figure E4-7. North American Rockwell also applies the matrix-management concept in their current organization with program offices (Saturn S-II, Space Station, CSM, Space Shuttle, etc.) superimposed on a basically functional organizational structure which includes Manufacturing, Research, Engineering, and Test; Material; Quality and Reliability Assurance; and the conventional administrative-support functions. The Apollo contract is managed for NR by the CSM Program Office headed by a division vice president. Figure E4-8 shows the organization of that Office. Within the CSM Program Office the principal suborganization for program management is Engineering, headed by an Assistant Program Manager and Chief Program Engineer. On the functional side of the Space Division, referring again to figure E4-7, line responsibility for

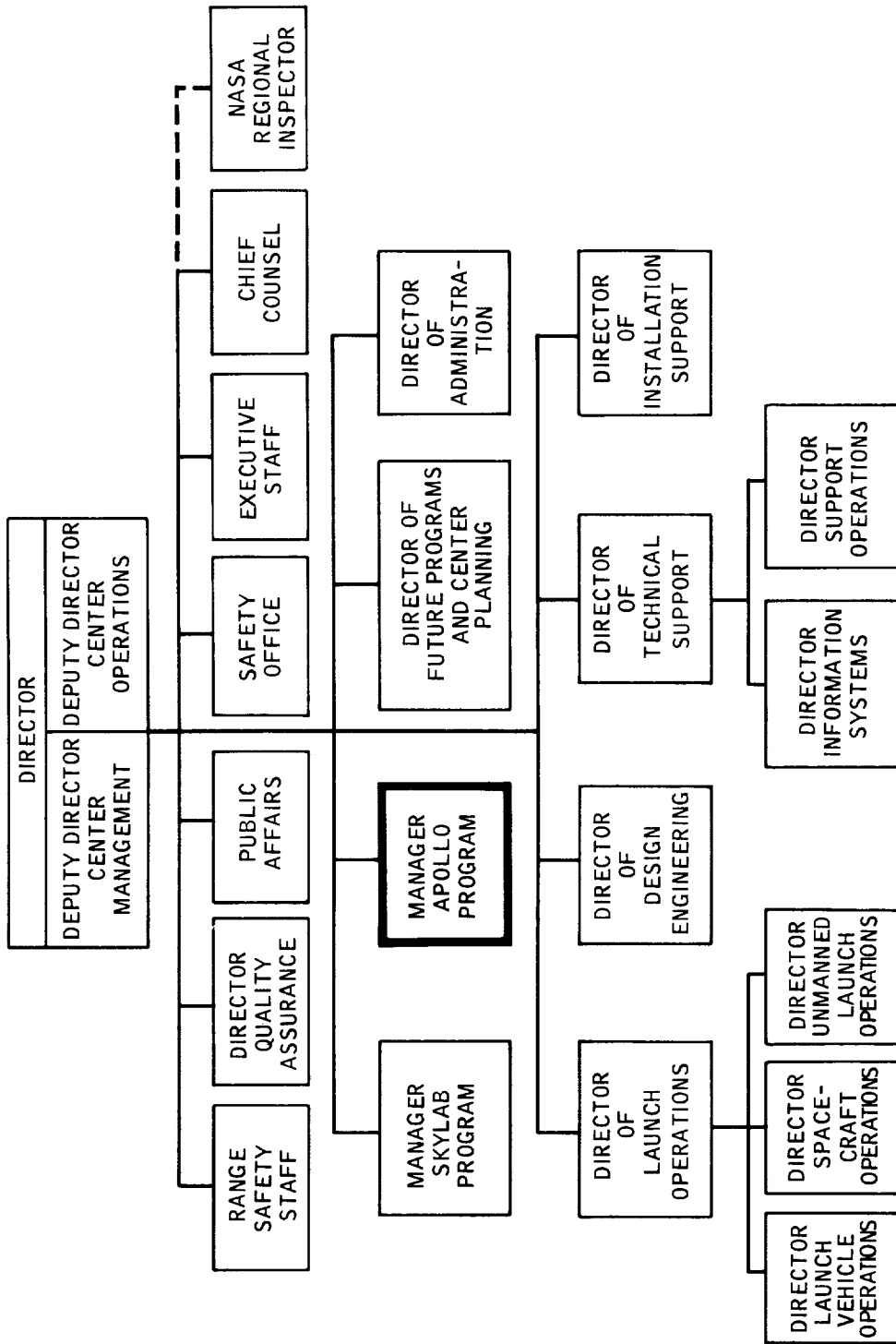

Figure E4-5.- Kennedy Space Center organization.

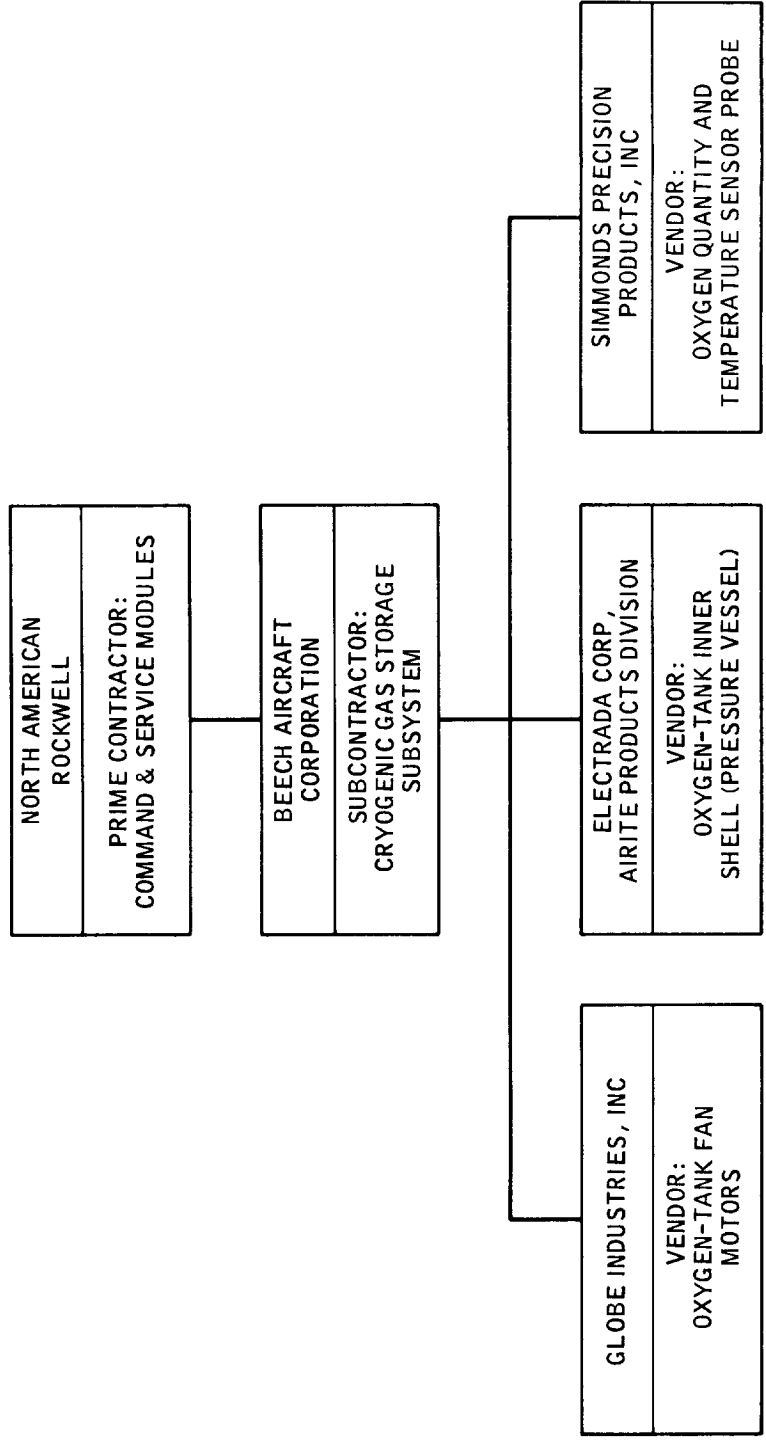

Figure E4-6.- Cryogenic gas storage subsystem-contractual relationships.

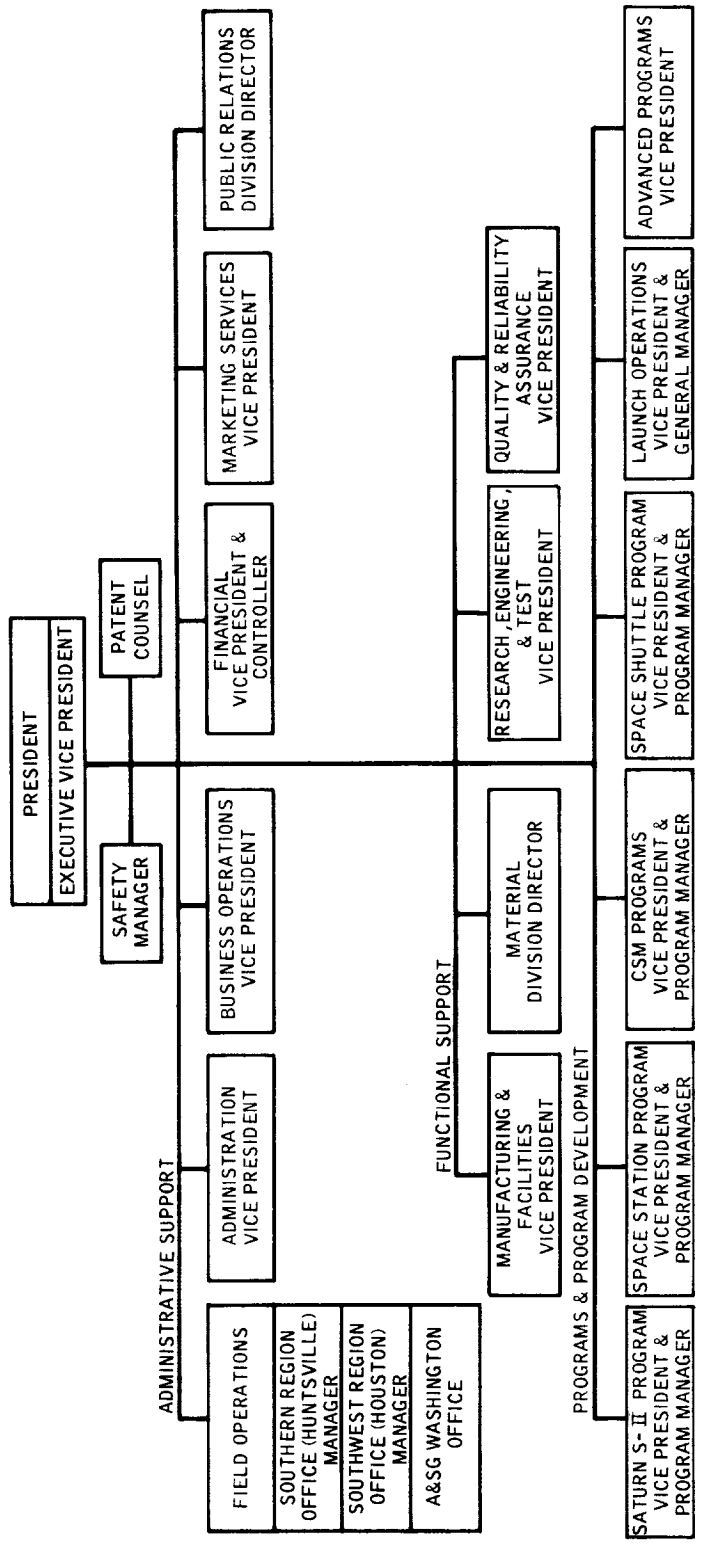

Figure E4-7.- North American Rockwell, Space Division organization.

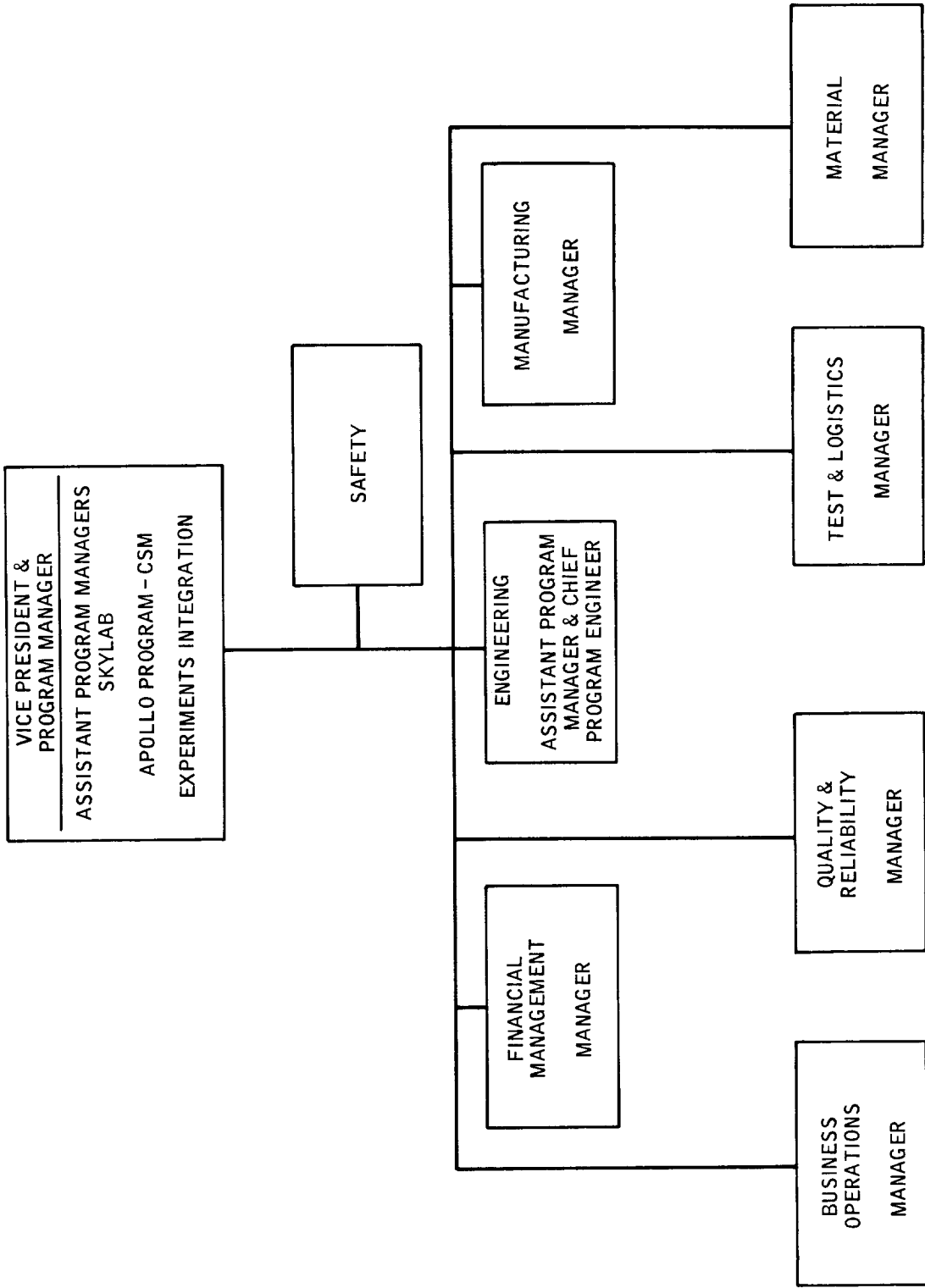

Figure E4-8.- North American Rockwell, Space Division, CSM Programs Office organization.

performance (as opposed to management) under the Apollo contract falls under the functional support organization for Research, Engineering, and Test, also headed by a division vice president. The organization of that Office is along systems/subsystems lines. At the subsystem level, the engineer in charge in this organization also acts as the subsystem manager for the program management organization, in a manner quite analogous to the technique used by the MSC organization described earlier. The relationship at North American Rockwell is illustrated in figure E4-9.

North American Launch Operations Space Division (KSC)

All NR CSM operations at KSC are conducted in accordance with the provisions of Supplement KSC-1 to MSC contract no. NAS9-150 with NR. The Supplement contains a statement of work prepared by KSC and KSC is responsible for technical direction to the NR personnel. The NR Apollo CSM Operations at KSC supports KSC in CSM checkout and launch and is a part of the NR Launch Operations Space Division under the NR Vice President and General Manager who is located at Cocoa Beach, Florida. He, in turn, reports to the Space Division President, NR.

Beech Aircraft Corporation

The subcontract from North American Rockwell, for manufacturing of the cryogenic gas storage subsystem, is held by the Boulder Division of the Beech Aircraft Corporation. The organization of that Division is shown in figure E4-10. Beech also uses the matrix-management concept with management responsibility for the Apollo subsystem contract vested in the Apollo Program Manager and performance responsibility in the Manager, Engineering. Figure E4-11 shows the breakdown of management responsibilities within the office of the Apollo Program Manager.

NORTH AMERICAN ROCKWELL

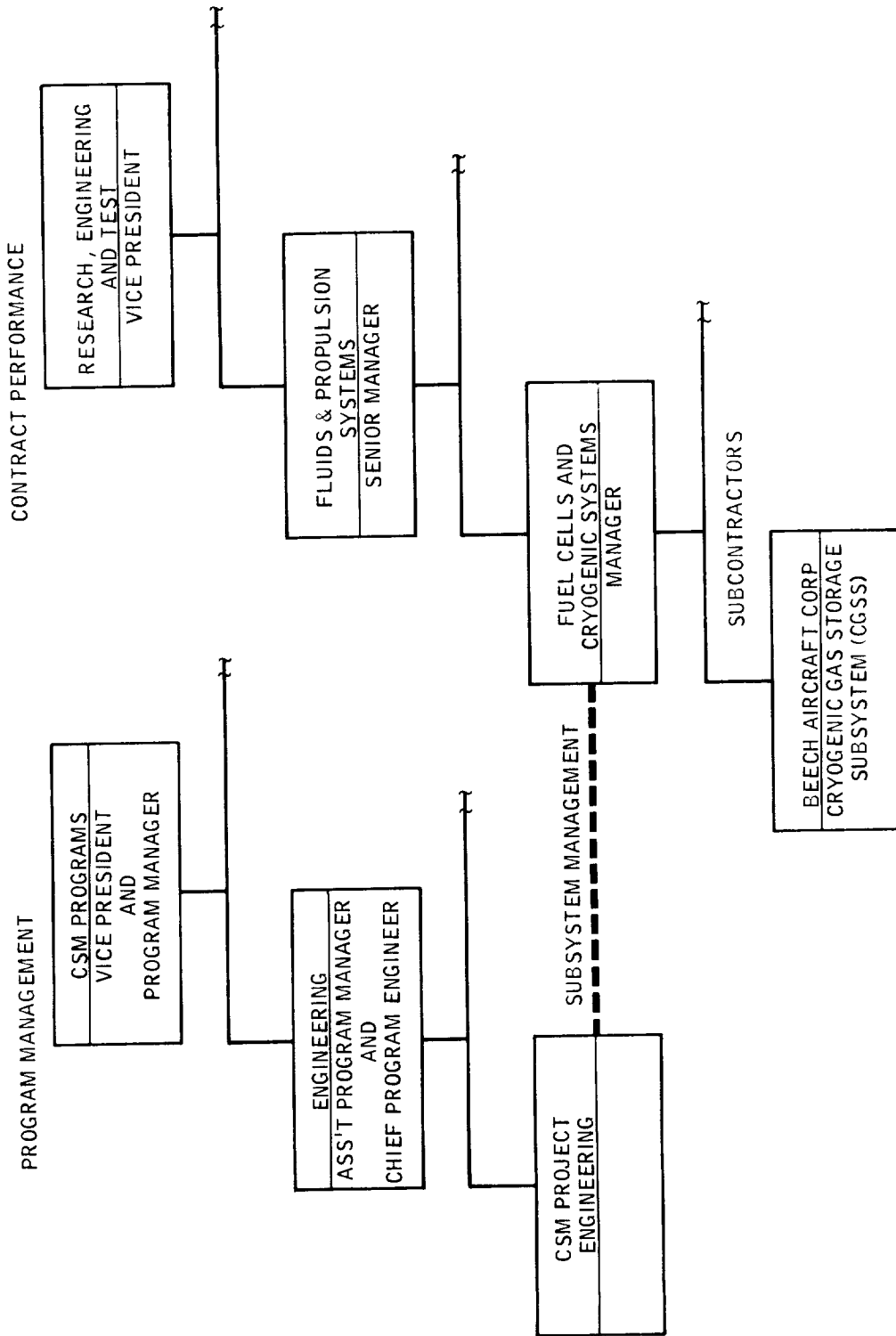

Figure E4-9.- North American Rockwell organizational relationships applicable to cryogenic gas storage subsystem.

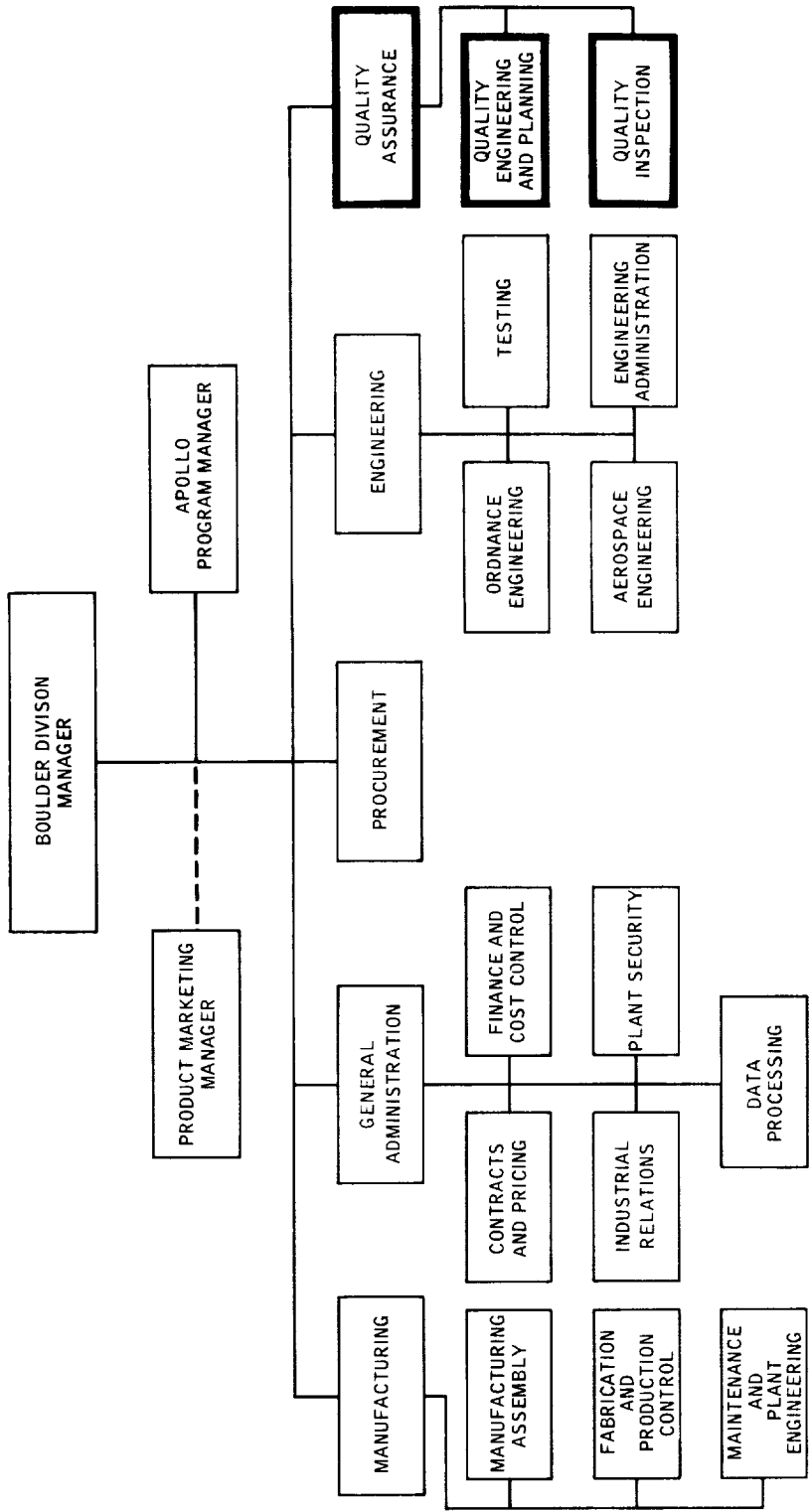

Figure E4-10.- Beech Aircraft Corporation organization.

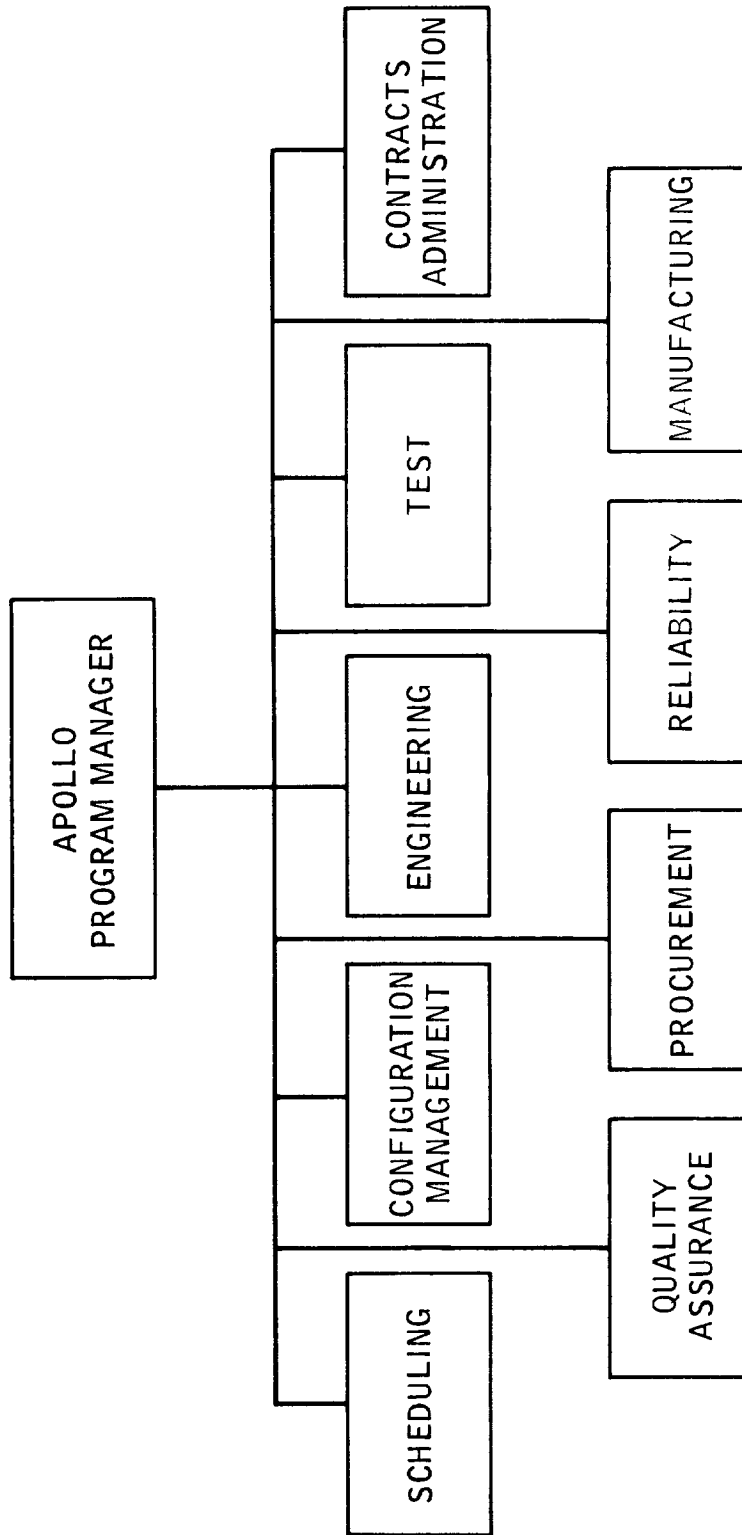

Figure E4-11.- Beech Aircraft Corporation, Boulder Division,
 Apollo Program Office organization.

This page left blank intentionally.

PART E5

RESPONSIBILITIES AND OPERATING RELATIONSHIPS

The specific responsibilities assigned to most of the NASA organizational elements involved in management of the Apollo Program are described in some detail in the series of documents titled NASA-Apollo Program Management. Where those descriptions are still pertinent, they are incorporated here by reference or are paraphrased as necessary to maintain the continuity of this document. The following discussion is, for the most part, confined to those organizations and responsibilities that are germane to the present study.

NASA ADMINISTRATOR

The Administrator of NASA reserves to his own office the authority for establishing and enforcing Agency policy, for establishing overall program policy and objectives, for approving mission plans and schedules, for mission funding and major procurement actions, and for insuring adherence to functional management policies. Apollo Program policies, objectives, and management systems are reviewed and approved by the Administrator, as are significant schedule and budget decisions. Management directives relating to the Program are issued within the Agency-wide NASA Issuance System, with special provisions for specific instructions and directives to be issued by the Apollo Program Director to participating program elements in the Manned Space Flight Field Centers.

ASSOCIATE ADMINISTRATOR FOR MANNED SPACE FLIGHT

As described earlier, the Associate Administrator for Manned Space Flight, serving as the Administrator's executive agent for the general management of all manned space flight programs, shares full responsibility with the Administrator for all aspects of these programs. In this capacity, he is advised by three major policy bodies: the Manned Space Flight Management Council, the Science and Technology Advisory Committee, and the Manned Space Flight Experiments Board. The responsibilities of these groups are summarized as follows.

Manned Space Flight Management Council

The Council consists of the Associate Administrator for Manned Space Flight as Chairman and the Directors of the three Manned Space Flight Centers. The Associate Administrator for Manned Space Flight establishes program policy guidelines and program plans in consultation with the Council. For the Apollo Program, the Council reviews policy, progress, and performance to assure that goals are being met, that technical problems are being dealt with properly, and that adequate resources are available for conduct of the planned program. The Council also acts as the Design Certification Board in examining the entire Program for proof of development maturity prior to each manned flight of a new configuration. To insure flightworthiness and manned flight safety, the Council assesses the design of the space vehicle launch complex, the Mission Control Center, the Manned Space Flight Network, and the launch instrumentation for manned Apollo missions. A Mission Design Certification Document, executed by the entire membership of the Council, serves as the approval authority for proceeding with specific flight missions designated for manned flight.

Science and Technology Advisory Committee

The Committee is made up of leading scientists and engineers from universities, industry, and Government. The Committee functions in an advisory capacity to the Associate Administrator for Manned Space Flight on major technical and scientific questions. They perform independent evaluations and make recommendations to the Associate Administrator for Manned Space Flight.

Manned Space Flight Experiments Board

The Board consists of the Associate Administrator for Manned Space Flight as Chairman, the Associate Administrators for Space Science and Applications and for Advanced Research and Technology, and representatives from the Department of Defense and the Air Force. The Board's responsibility is to advise and recommend to the Associate Administrator for Manned Space Flight which experiments should be included in manned space flight missions.

APOLLO PROGRAM DIRECTOR

Full responsibility and authority for managing all aspects of the Program within the constraints of budget, schedule, and performance

approved by the Administrator are delegated to the Apollo Program Director by the Associate Administrator for Manned Space Flight. It is the Program Director's responsibility to define or approve mission requirements, technical requirements, program specifications, and reliability, quality assurance, and safety standards. His office is organized into the five functional Directorates shown in figure E5-1. The Apollo Program Offices in the three Manned Space Flight Centers have organizational structures similar to that of the Program Director's, thus providing parallel responsibilities for managers at the two levels. The responsibilities of four of the five Directorates in the Apollo Program Office are described in the following paragraphs.

Test Directorate

The Test Directorate is responsible for planning and coordinating development of test programs for all phases of design, manufacture, and checkout of launch vehicles, spacecraft, experiment hardware, and ground support equipment. The Directorate coordinates requirements for test facilities, and prepares and justifies budget requests for test programs and facilities.

Operations Directorate

The Operations Directorate is responsible for operations plans and schedules; operations documentation; mission test plans; flight plans; trajectory design and analysis; crew operations and training; premission operations checkout, mission safety, and hazard probabilities; and mission operations support.

Systems Engineering Directorate

The Systems Engineering Directorate is responsible for developing the Apollo Program Specifications; developing flight mission assignments (including mission objectives and overall flight profiles); reviewing program to define technical interfaces; establishing control weights for vehicle stages and spacecraft modules; and verifying that system performance requirements are achieved.

Program Control Directorate

The Program Control Directorate is responsible for integrated planning; preparation of Program Development Plans; maintaining interrelated schedules; logistics; specifications; performance analysis and control system management; configuration management; data management systems;

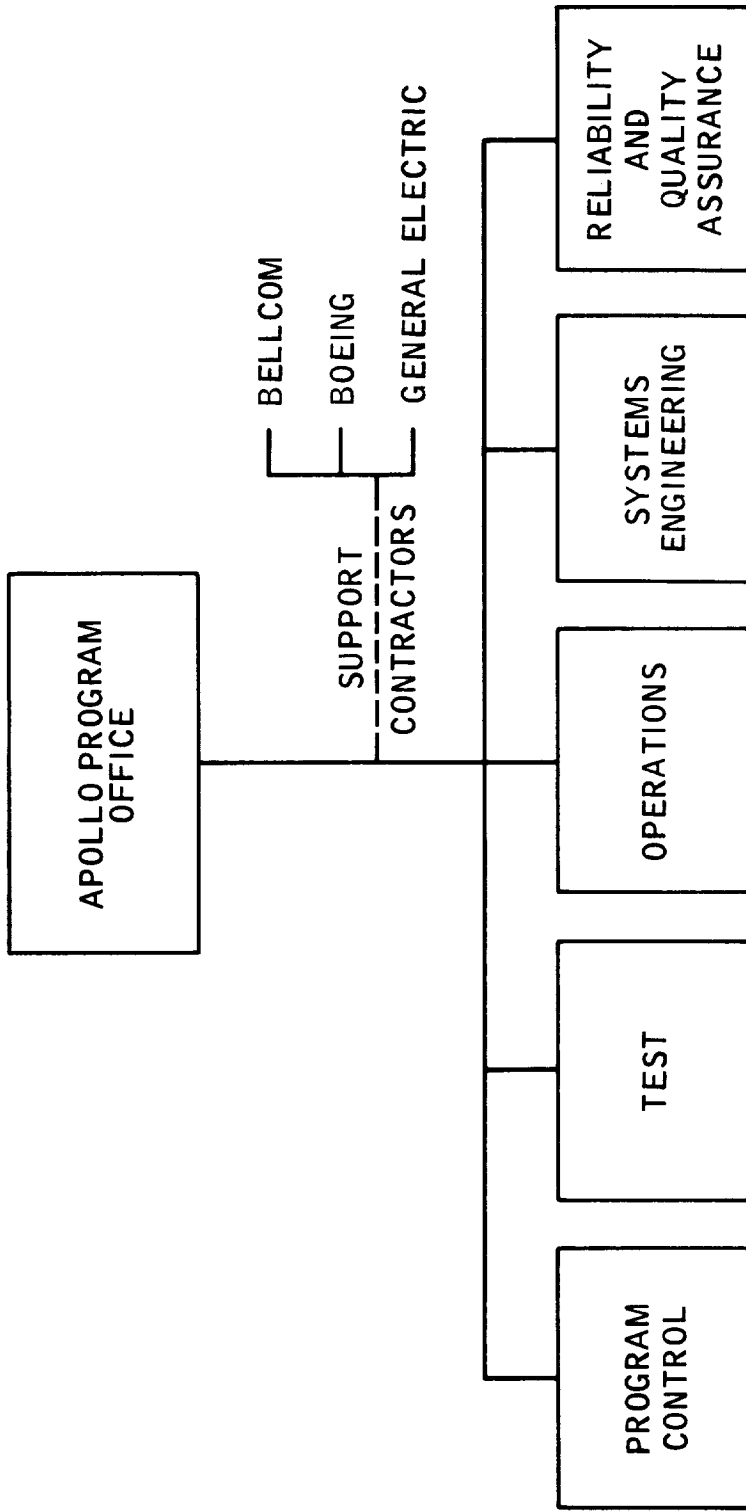

Figure E5-1.- Functional organization of the Apollo Program Office, NASA Headquarters.

preparation of budget and cost information; and operation of the Apollo Action Center.

Reliability and Quality Assurance (R&QA) Directorate

The R&QA Directorate is responsible for initiating program-wide R&QA policies and procedures; preparing program development plans for the Manned Space Flight Centers; developing R&QA training programs; establishing R&QA reporting requirements; and evaluating the effectiveness of R&QA programs in the Centers.

Support Contractors

The Apollo Program Director also has the services of three support contractors available to him:

1. Bellcomm, Inc. (AT&T), which provides systems engineering support consisting of studies, technical evaluations, analytical investigations, and technical consulting services.

2. The Boeing Company, Space Division, which performs the technical integration and evaluation function for the Program Director. This includes analyses and evaluation of program management, interface control, configuration management, logistics, engineering, manufacturing, testing, launch operations, and information systems.

3. General Electric Company, Apollo Systems Development, which provides general engineering support, including data management, management information systems, and R&QA investigations.

MSC APOLLO SPACECRAFT PROGRAM OFFICE (ASPO)

As in the Headquarters organization, the Apollo Spacecraft Program Manager at MSC acts for the MSC Center Director as general manager of all Apollo-related activities at the Center. In that capacity he is the official technical interface between NASA and the spacecraft contractors. He is responsible for managing the accomplishment of all Apollo tasks at the Center, even though many of those tasks are performed by Center personnel not organizationally responsible to him. His functional responsibilities essentially parallel those of the Apollo Program Director, but are applicable to the spacecraft only while those of the Program Director encompass all aspects of the Program. His Program Office organization is also essentially parallel to that of

the Program Director's, as shown in figure E5-2. He has delegated to three subordinate Managers (for the CSM, the LM, and Experiments and GFE) the following responsibilities:

1. Directing the design, development, and fabrication programs carried out by the contractors.
2. Directing and planning systems engineering and systems integration functions, including review of engineering design and systems engineering studies conducted by the contractors.
3. Developing the ground- and flight-test programs to be conducted at White Sands, MSC, and KSC.
4. Monitoring contractor operations to assure adherence to specifications and to identify and solve problems in the development and fabrication of systems and subsystems.
5. Chairing the Configuration Control Board (Level 3).

Assistant Program Manager for Flight Safety

There is also within the Apollo Spacecraft Program Office an Assistant Program Manager for Flight Safety, whose responsibility is to assure that the policies and procedures of MSC's Safety Office are adhered to in all Apollo Program activities relating to the spacecraft. He is the Apollo Spacecraft Program Manager's Safety representative to KSC and the spacecraft contractors. He oversees all program activities from a flight safety viewpoint and is an advisor to the Program Manager on the flightworthiness of all systems.

Systems Engineering Division

Referring again to figure E5-2, there are six functional divisions reporting to the Apollo Spacecraft Program Manager. Two of these perform functions that have a direct bearing on the development and manufacture of the cryogenic gas storage subsystem. The Systems Engineering Division is responsible for the coordination and control of the design and development of all spacecraft systems. The Division determines the technical requirements, and develops technical specifications (with the contractor) for systems and subsystems, and is responsible for assuring that all program elements (crew, hardware, and software) are successfully integrated into each system design. This Division plays its major role during the design and development stage of the spacecraft and its systems. It is responsible for organizing and conducting all Preliminary Design Reviews and Critical Design Reviews. It is also responsible

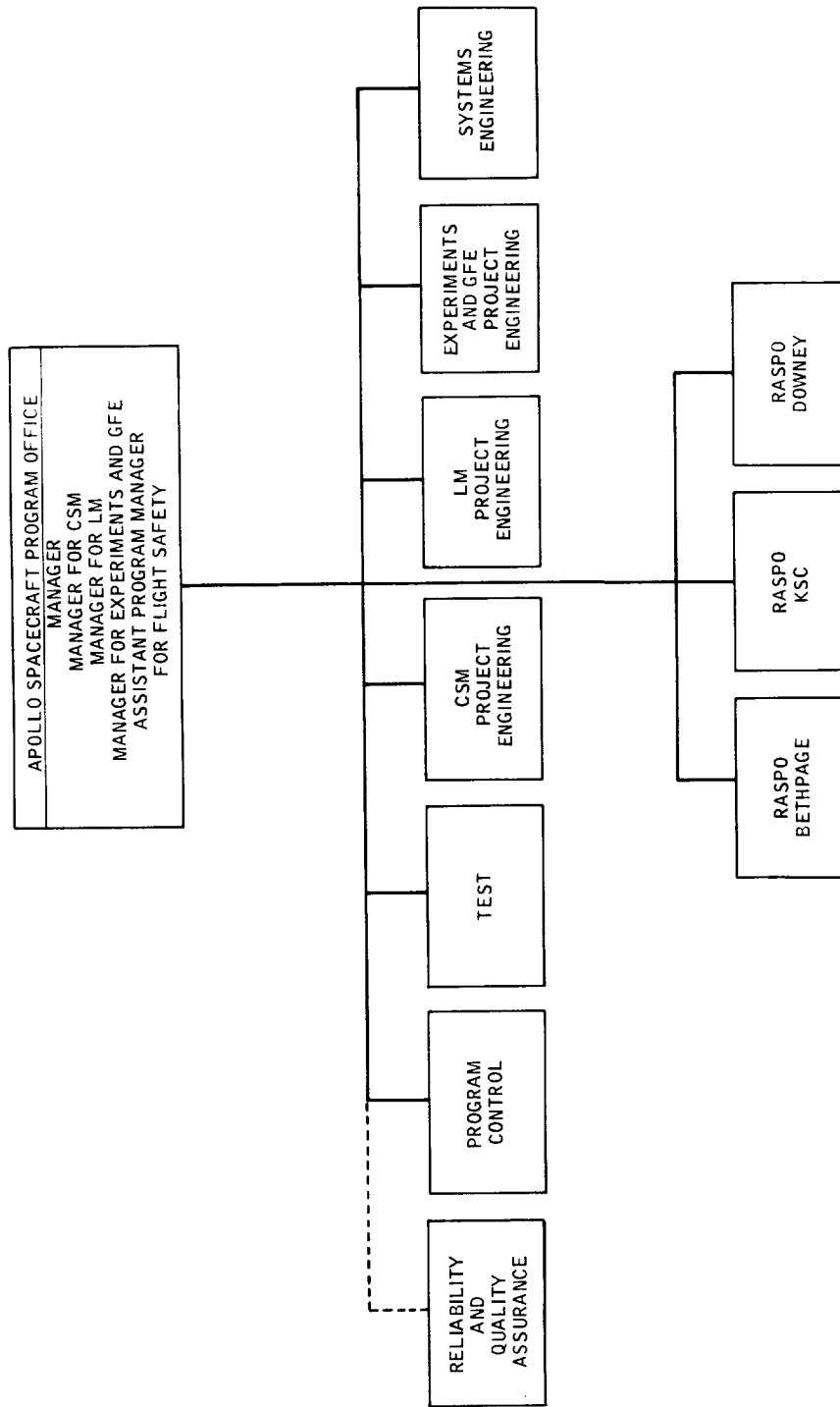

Figure E5-2.- Functional organization of the Apollo Spacecraft Program.

for definition and implementation of the nonmetallic materials program. Mission definition and planning are also major responsibilities.

CSM Project Engineering Division

This Division, which has counterpart Divisions for the LM and for Experiments and GFE, plays its major role during manufacture and test of the spacecraft. From this Division two engineers, designated as Project Engineers, are assigned to each spacecraft as it begins manufacture. The Project Engineers are the Program Manager's representatives for his particular spacecraft and are responsible for assuring that that particular spacecraft is ready for launch on schedule, that it has successfully passed all tests, inspections, and reviews, and that all associated ground support equipment is on schedule. Their responsibility extends up to launch and resumes after recovery for postflight testing.

Resident Apollo Spacecraft Program Offices (RASPO)

There are Resident Apollo Spacecraft Program Managers at the North American Rockwell plant, Downey, California (for the CSM prime contract), at Bethpage, New York (for the LM prime contract), and at the Kennedy Space Center (for launch activities). The Managers of the RASPO-Downey and the RASPO-Bethpage act for the Apollo Spacecraft Program Manager in all spacecraft activities taking place at their locations. Their responsibilities encompass program control, manufacture, test and checkout, and configuration management. The Manager at the RASPO-Kennedy represents the Apollo Spacecraft Program Manager in all operations at KSC which relate to the spacecraft. Specific responsibilities include:

1. Liaison with the KSC Spacecraft Operations Director on all matters relating to spacecraft preparation and checkout for launch.
2. Submission to KSC of MSC's prelaunch test and checkout requirements for the spacecraft.
3. Approval of KSC's Test and Checkout Plans.
4. Approval of waivers and deviations to MSC's test and checkout requirements.
5. Restricted change approval related to GSE and test operations.

MSC RELIABILITY AND QUALITY ASSURANCE (R&QA) OFFICE

The R&QA Office at MSC is an independent functional office reporting to the Director of the Center and responsive to the ASPO. It has overall responsibility for planning, coordinating, and directing all R&QA activities at the Center. Specific responsibilities include:

1. Establishing reliability, quality, and inspection requirements and criteria for spacecraft, systems, subsystems, and supporting equipment.
2. Insuring implementation of R&QA requirements and criteria at contractor plants and at MSC.
3. Developing MSC engineering design standards and criteria.
4. Establishing certification test criteria and approving certification test plans and reports.
5. Establishing and enforcing policies governing parts and materials identification, usage, and qualification information for critical spacecraft hardware.

MSC SAFETY OFFICE

The Safety Office at MSC is also an independent functional office, reporting to the Center Director. It is responsible for establishing safety policies, standards, and procedures in the fields of industrial operations and manned space flight. Specific responsibilities include:

1. Review and evaluation of the safety of operations in all Center organizations.
2. Advising the Center Director and Center Management on all matters relating to industrial and flight safety.
3. Reviewing and evaluating the effectiveness of contractor safety programs against MSC safety standards and criteria.

MSC ENGINEERING AND DEVELOPMENT DIRECTORATE

The Engineering and Development Directorate is the principal engineering component of the Center functional organization. This Directorate, organized into Divisions by technical discipline, conducts most of the Center's supporting research and technology, develops concepts for advanced systems, and provides technical support to all on-going flight programs. This support roughly subdivides into three major categories:

1. Systems analyses and definition of new techniques applicable to space flight programs.
2. Subsystem and component tests.
3. Technical management of the design, manufacture, and testing of subsystems by the Program contractors.

This latter function represents a major element of the Apollo Program management system and is described as follows:

The three subordinate Managers in the ASPO (for CSM, LM, and Experiments and GFE) rely heavily on the matrix management concept for carrying out their responsibilities. They receive technical support from subsystem managers appointed from the technical Directorates of the Center's line organization. There are between 40 and 50 subsystem managers, most of them located in the Engineering and Development Directorate (fig. E4-4). The Subsystem Manager for the cryogenic gas storage subsystem is organizationally located in the Propulsion and Power Division of that Directorate. These managers remain assigned to their permanent organizations, but assume program responsibility for the design, development, and manufacture of particular subsystems. In this role they report to the Module Manager (e.g., Manager for the CSM) in the Program Office. For all other purposes they report through normal organizational lines. The subsystem manager's responsibility for his subsystem is continuous from preliminary design through operations. He is the Program Office's technical manager of all work done on the subsystem (although contractor direction is given through the Project Officer or Contracting Officer) and is responsible for assuring that the subsystem is built on schedule, within budget, and to specifications.

KSC APOLLO PROGRAM MANAGER

The Apollo Program Manager at KSC represents the Center Director in all matters relating to the launch of an Apollo space vehicle. He develops all necessary plans for work to be accomplished at KSC for the Apollo Program and issues "requirements" to the line organizations of the Center. The line organizations then assume full responsibility for conducting their parts of the Program, and the role of the Apollo Program Manager becomes one of monitoring, assessing, and modifying requirements as necessary. The organization of the KSC Apollo Program Office is shown in figure E5-3.

KSC DIRECTOR OF LAUNCH OPERATIONS

This organization has the principal functional responsibility for conducting the launch of the Apollo space vehicle. The Director of Launch Operations is responsible for the management and technical direction of preflight operation and integration, assembly, test, check-out, and launch of all space vehicles. He initiates, supervises, and coordinates the preparation of preflight and launch operations test plans and assures their effective execution. He assists the Apollo Program Manager in negotiating test and operational sequences, methods, and standards with the two development Centers (MSC and MSFC).

INTER-CENTER RELATIONSHIPS

Because the day-to-day management of the Apollo Program, from design through launch, requires close coordination of activities underway at three field Centers and in NASA Headquarters, formally documented Inter-Center Agreements have been drawn to specify how responsibilities are divided and how the activities at each location relate to those at the others. Additionally, a series of Inter-Center Coordination Panels has been established which recommend solutions to technical interface problems involving the responsibilities of two or more Centers. There are eight such panels, covering: Crew Safety, Electrical, Flight Evaluation, Mechanical, Instrumentation and Communications, Flight Mechanics, Launch Operations, and Flight Operations. All panels operate under the cognizance of a Panel Review Board made up of representatives from the three Manned Space Flight Centers and the Headquarters Office of Manned Space Flight.

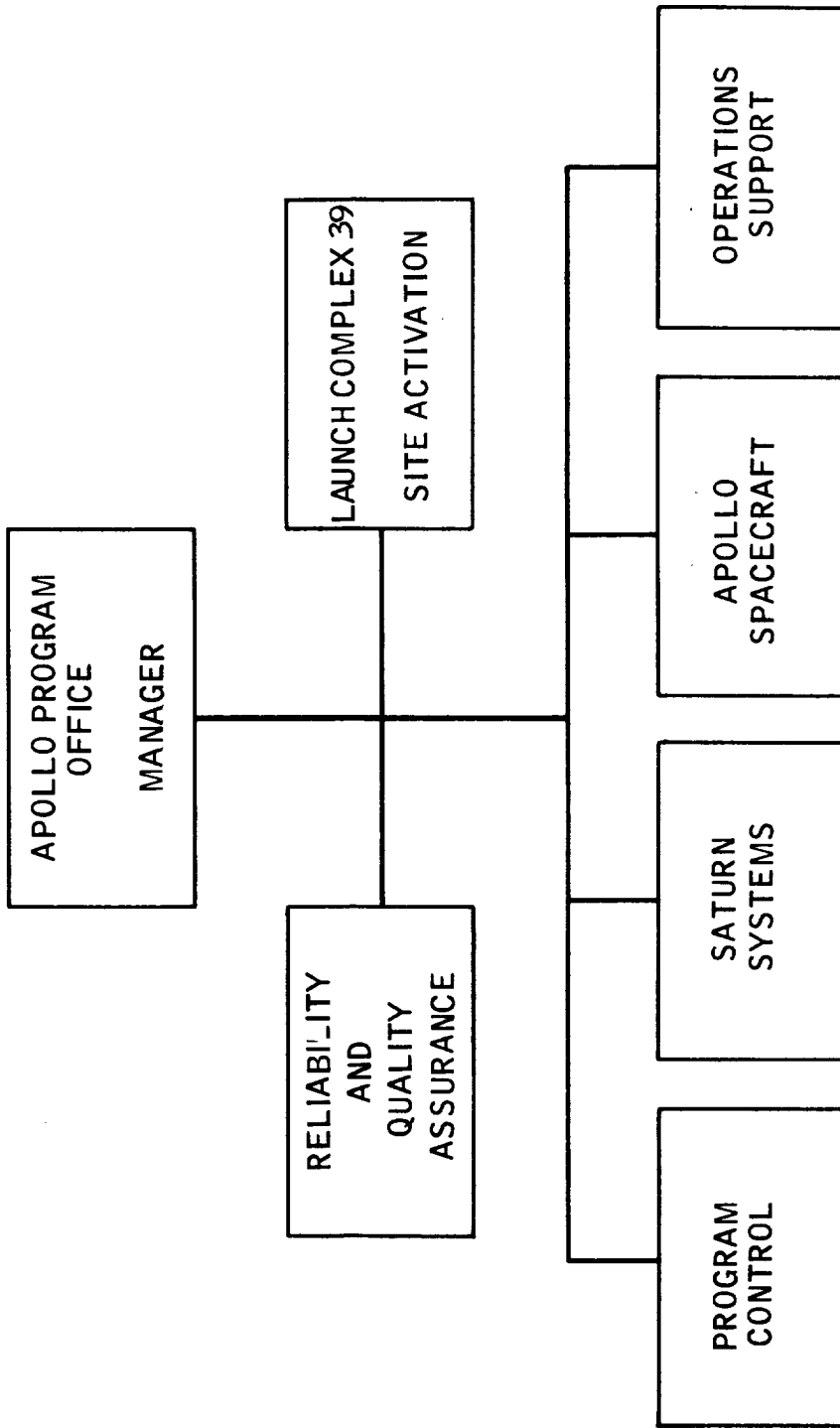

Figure E5-3.- Functional organization of the Apollo Program Office at KSC.

Apollo Program Directive No. 33A, issued in August 1968, defines in considerable detail the responsibilities of each of the three Centers in the Apollo Program. It is reproduced on the following pages in its entirety for reference.

5 AUG 1968

APOLLO PROGRAM DIRECTIVE NO. 33A

TO: DISTRIBUTION

FROM: *Stan C. Culbert*
APOLLO PROGRAM DIRECTOR

SUBJECT: Center Responsibilities in the Apollo Program

OFFICE OF PRIME RESPONSIBILITY: MAP

I. PURPOSE

The purpose of this Directive is to assign responsibility and functions and define inter-Center relationships for the conduct of the Apollo Program.

II. SCOPE

This Directive assigns responsibilities and functions to MSF Centers for accomplishment of the Apollo Program in amplification of and in consonance with NMI 1142.1 Functions and Authority - Manned Spacecraft Center, NMI 1142.3 Functions and Authority - George C. Marshall Space Flight Center, and NMI 1142.2 Functions and Authority - John F. Kennedy Space Center.

III. RESPONSIBILITY

- A. The Director of the Manned Spacecraft Center is responsible for design, development, fabrication, qualification, acceptance test and delivery of Apollo spacecraft; associated ground support equipment and assigned experiments; for the planning of all Apollo Missions; for the control of the flight phase of Apollo Missions including the development of ground equipment necessary for mission control and not provided by other centers in the execution of their missions; for the selection, training and assignment of flight crews; for the development of software as needed for spacecraft guidance, checkout, and mission control; for establishing prelaunch requirements for test, checkout and inspection of Apollo spacecraft; and for the planning and implementation of a lunar science program to support the Apollo Program.
- B. The Director of the George C. Marshall Space Flight Center is responsible for the design, development, fabrication, qualification, acceptance test and delivery of the Saturn launch vehicles including engines, associated ground support equipment and assigned experiments; providing mission planning data from the standpoint of overall vehicle performance; providing launch vehicle data and software for launch vehicle guidance and checkout; for establishing prelaunch requirements for test, checkout and inspection of Saturn launch vehicles; and supporting launch and flight operations as requested by KSC and MSC.

- C. The Director of the John F. Kennedy Space Center is responsible for development and operation of launch and industrial facilities and associated ground support equipment required to support the Apollo Program and the assembly, test, inspection, checkout and launch of Apollo-Saturn space vehicles at KSC.
- D. Center Directors will retain ultimate responsibility for Apollo Program functions delegated within the Center, and will supervise their performance. Significant changes in delegation of functions will be discussed with the Apollo Program Director prior to implementation.

IV. FUNCTIONS

A. Manned Spacecraft Center

The Manned Spacecraft Center is assigned the following functions for the Apollo Program:

1. Hardware

- a. Providing for the detailed specifications, design, manufacture, checkout, test, reliability and quality, qualification, and acceptance of MSC developed hardware. This does not include the test and checkout functions accomplished at the launch site by KSC.
- b. Developing and delivering to KSC spacecraft which has been qualified for flight along with associated software, data and support equipment.
- c. Providing for the detailed specifications, design, development, fabrication, qualification, acceptance test and delivery of experiments flight hardware and associated specialized ground equipment for those experiments approved by the Manned Space Flight Experiments Board and assigned by the Apollo Program Director.
- d. Providing logistic support planning and implementation at factory, test and launch sites for MSC developed hardware.
- e. Controlling receipt and stowage of flight crew personal equipment at KSC which is scheduled for flight and providing to KSC a list of equipment which is considered flight crew personal equipment.

2. Configuration Control

- a. Establishing and controlling configuration of spacecraft hardware, associated software and support equipment (designed or provided by MSC) at each stage of preparation or test in the factory, test or launch site, including approval of changes at KSC.

- b. Providing and maintaining a list of acceptable items and materials that may enter the spacecraft for checkout and for flight.

3. Test and Checkout

- a. Establishing and maintaining test and checkout requirements and test and checkout specifications and criteria for factory or test site acceptance and launch site preparation of MSC developed hardware (including Ground Support Equipment and software).
- b. Providing test and checkout requirements and test and checkout specifications and criteria for launch site preparation of MSC developed hardware, software and Ground Support Equipment.
- c. Reviewing factory, test site and launch site test requirements and test and checkout plans and procedures as necessary to assure that adequate testing is being accomplished without unnecessary overlap and duplication between testing conducted at different locations.
- d. Providing written approval of KSC test and checkout plans in consonance with paragraphs IV.A.3b and IV.A.3c.
- e. Providing Center approved factory or test site test and checkout procedures to KSC for use as a baseline in the development of similar procedures required at the launch site.
- f. Reviewing at the option of MSC, the adequacy of KSC test procedures at the launch site.
- g. Providing requirements and criteria to KSC for assuring flight readiness of experiments flight hardware, unless KSC and MSC on the basis of written agreement for a specific experiment make other arrangements for flight readiness determination.
- h. Determining functional performance and flight readiness of flight hardware closed out at the factory or test site and not accessible for inspection or not included in test and checkout requirements for evaluation of functional performance at KSC.
- i. Providing such technical assistance or data as may be required by KSC in preparation of hardware for flight.
- j. Assuring that MSC personnel participating in KSC tests are responsive to KSC direction during conduct of the tests and attend pre-test briefings and participate in training exercises as required by KSC in accordance with responsibilities outlined herein.
- k. Providing an assessment of flight readiness of the spacecraft and associated software at the Flight Readiness Review in accordance with Apollo Program Directives.

4. Reliability and Quality Assurance

- a. Providing quality control requirements and inspection criteria for MSC developed hardware for use at the factory, test site and launch site.
- b. Conducting audits to evaluate contractor factory and test site performance in accordance with MSC quality control requirements and inspection criteria for MSC developed hardware, and participating at the option of MSC in audits conducted by KSC at the launch site.
- c. Determining corrective action and disposition of MSC developed hardware which fails, malfunctions or performs outside the performance limits contained in test and checkout specifications and criteria during checkout at KSC. This responsibility does not include routine trouble-shooting or maintenance of MSC developed ground support equipment operated by KSC.

5. Systems Engineering

Providing MSC technical representation on design and operations inter-Center panels or working groups as established by Apollo Program Directives.

6. Operations

- a. Developing flight techniques for mission control and hardware and software for the Mission Control Center.
- b. Developing mission objectives, plans and rules to support Apollo mission assignments.
- c. Conducting flight operations.
- d. Obtaining from KSC the operational requirements pertaining to checkout and launch which need to be incorporated into MSC designed hardware.
- e. Planning jointly with the Department of Defense the provision of recovery support.
- f. Providing input to and comment on KSC launch rules.
- g. Identifying MSC operational support requirements according to approved procedures and evaluating support implementation of said requirements.

7. Flight Crew

- a. Providing trained flight crews and personal equipment for manned missions.
- b. Directing all astronaut activities except during the time they are participating in KSC flight hardware tests.
- c. Developing and operating flight crew simulators and training equipment at MSC and KSC.

8. Science

- a. Planning and implementation of a lunar science program to support Apollo, including site selection, lunar science operations, the Lunar Receiving Laboratory operation and lunar sample analysis.

9. Management

This section contains general management responsibilities for the conduct of the Apollo program at MSC as well as some specific management requirements which need to be highlighted.

General

- a. Assuring that Apollo program requirements for manpower or for institutional support from other elements of MSC are properly conveyed to those elements and that Apollo program institutional support requirements are reflected in Center resource requirements plans, schedules, and budgets.
- b. Assuring that Apollo program requirements for institutional support are met on an effective and timely basis.
- c. Developing and operating Center facilities required for the Apollo Program.
- d. Developing and implementing adequate security procedures.
- e. Establishing detailed schedules (Levels 2, 3 and 4) for MSC hardware, software and associated equipment and operations activities consistent with the basic schedules (Level 1) approved by the Director, Apollo Program, and the Director, Mission Operations.
- f. Providing contract authority for KSC control of spacecraft contractor's test and checkout activities at KSC through a supplemental contract under KSC administration.

Medical

Medical support for the Apollo program will be provided in accordance with NMI 8900.1. In addition, the following specific requirements will be met on the Apollo program.

- a. Providing for the medical surveillance and support of the astronauts during all phases of the Apollo Program at any location including test and checkout operations.
- b. Providing for the evaluation of medical data obtained during manned tests, to insure that the interpretation of such data regarding the acceptability of equipment performance is properly reflected in post flight mission reports.
- c. Providing for the development and implementation of medical disaster plans associated with the test of Apollo hardware at MSC.

Safety

Safety activities in the Apollo program will be conducted in accordance with instructions provided by the Apollo Program Director and directives issued by the Manned Space Flight and NASA Safety Directors. In addition the following specific requirements will be met on the Apollo program.

- a. Providing written approval of KSC criteria for determining hazardous operations at the launch site.
- b. Reviewing and approving any KSC test and checkout procedure in which the flight crew participates.

B. George C. Marshall Space Flight Center

The George C. Marshall Space Flight Center is assigned the following functions for the Apollo Program.

1. Hardware

- a. Providing for the detailed specifications, design, manufacture, checkout, test, reliability and quality, qualification and acceptance of MSFC developed hardware. This does not include the test and checkout functions accomplished at the launch site by KSC.
- b. Developing and delivering to KSC launch vehicles which have been qualified for flight along with associated software, data and support equipment.
- c. Providing for the detailed specifications, design, development, fabrication, qualification, acceptance test and delivery of experiments flight hardware and associated specialized ground equipment for those experiments approved by the Manned Space Flight Experiments Board and assigned by the Apollo Program Director.
- d. Providing logistic support planning and implementation at factory, test and launch sites for MSFC controlled hardware.

2. Configuration Control

- a. Establishing and controlling configuration of launch vehicle hardware, associated software and support equipment (designed or provided by MSFC) at each stage of preparation or test in the factory, test or launch site, including approval of changes-at KSC.
- b. Providing criteria to KSC for controlling tools, equipment and materials that enter and leave the launch vehicle stages and instrument unit during operations at KSC.

3. Test and Checkout

- a. Establishing and maintaining test and checkout requirements and test and checkout specifications and criteria for factory or test site acceptance and launch site preparation of MSFC developed hardware (including Ground Support Equipment and software).
- b. Providing test and checkout requirements and test and checkout specifications and criteria for launch site preparation of MSFC developed hardware, software and Ground Support Equipment.
- c. Reviewing factory, test site and launch site test requirements and test and checkout plans and procedures as necessary to assure that adequate testing is being accomplished.
- d. Providing written approval of KSC test and checkout plans in consonance with paragraphs IV.B.3b and IV.B.3c.
- e. Providing Center approved factory or test site test and checkout procedures to KSC for use as a baseline in the development of similar procedures required at the launch site.

- f. Reviewing at the option of MSFC, the adequacy of KSC test procedures at the launch site.
- g. Providing requirements and criteria to KSC for assuring flight readiness of experiments flight hardware, unless KSC and MSFC on the basis of written agreement for a specific experiment make other arrangements for flight readiness determination.
- h. Determining functional performance and flight readiness of flight hardware closed out at the factory or test site and not accessible for inspection or not included in test and checkout requirements for evaluation of functional performance at KSC.
- i. Providing such technical assistance or data as may be required by KSC in preparation of hardware for flight.
- j. Assuring that MSFC personnel participating in KSC tests are responsive to KSC direction during conduct of the tests and attend pre-test briefings and participate in training exercises as required by KSC in accordance with responsibilities outlined herein.
- k. Providing an assessment of flight readiness of the launch vehicle and associated software at the Flight Readiness Review in accordance with Apollo Program Directives.

4. Reliability and Quality Assurance

- a. Providing quality control requirements and inspection criteria for MSFC developed hardware for use at the factory, test site and launch site.
- b. Conducting audits to evaluate contractor factory and test site performance in accordance with MSFC quality control requirements and inspection criteria for MSFC developed hardware, and participating at the option of MSFC in audits conducted by KSC at the launch site.
- c. Determining corrective action and disposition of MSFC developed hardware which fails, malfunctions, or performs outside the performance limits contained in test and checkout specifications and criteria during checkout at KSC. This responsibility does not include routine troubleshooting or maintenance of MSFC-developed ground support equipment operated by KSC.

5. Systems Engineering

- a. Providing MSFC technical representation on design and operations inter-Center panels or working groups as established by Apollo Program Directives.
- b. Providing the overall integrated space vehicle systems analysis and criteria for operational requirements and limitations for handling, checkout, launch and flight as required by MSFC, MSC and KSC.
- c. Operating the Manned Space Flight Interface Documentation Repository.

6. Operations

- a. Developing mission objectives and plans to support Apollo mission assignments.
- b. Providing real time mission support as requested by MSC and KSC both on site and at Huntsville.
- c. Providing input to and comment on KSC launch and MSC flight mission rules.
- d. Obtaining from KSC the operational requirements pertaining to checkout and launch which need to be incorporated into MSFC designed hardware.
- e. Identifying MSFC operational support requirements according to approved procedures and evaluating support implementation of said requirements.

7. Flight Crew

Providing instructions and material for training and familiarization of flight crews with the Saturn vehicle.

8. Science

None

9. Management

This section contains general management responsibilities for the conduct of the Apollo program at MSFC as well as some specific management requirements which need to be highlighted.

General

- a. Assuring that Apollo program requirements for manpower or for institutional support from other elements of MSFC are properly conveyed to those elements and that Apollo program institutional support requirements are reflected in Center resource requirements plans, schedules, and budgets.
- b. Assuring that Apollo program requirements for institutional support are met on an effective and timely basis.
- c. Developing and operating Center facilities required for the Apollo Program.
- d. Developing and implementing adequate security procedures.
- e. Establishing detailed schedules (Levels 2, 3 and 4) for MSFC hardware, software, and associated equipment consistent with the basic schedules (Level 1) approved by the Apollo Program Director.
- f. Providing liquid hydrogen management for MSFC and KSC.

- g. Providing contract authority for KSC control of launch vehicle contractor's test and checkout activities at KSC through a supplemental contract under KSC administration.

Medical

Medical support for the Apollo program will be provided in accordance with NMI 8900.1. In addition, the following specific requirement will be met on the Apollo program.

- a. Providing for the development and implementation of medical disaster plans associated with the test of Saturn hardware at MSFC.

Safety

Safety activities in the Apollo program will be conducted in accordance with instruction provided by the Apollo Program Director and directives issued by the Manned Space Flight and NASA Safety Directors. In addition the following specific requirement will be met on the Apollo program.

- a. Providing written approval on KSC criteria for determining hazardous operations at the launch site.

C. John F. Kennedy Space Center

The John F. Kennedy Space Center is assigned the following functions for the Apollo Program.

1. Hardware

- a. Providing for detailed specifications, design, manufacture, checkout, test, reliability and quality, qualification and acceptance of KSC developed hardware.
- b. Developing and delivering qualified ground support equipment associated with launch facilities and not provided by MSC or MSFC.
- c. Developing and operating ground communications, computation, and instrumentation systems and equipment for the conduct of launch operations.
- d. Taking measures to protect flight hardware and associated Ground Support Equipment from contamination, corrosion or damage which may result from environment, housekeeping, procedure or human error and reporting incidents to MSC and MSFC as appropriate.
- e. Providing logistics support planning and implementation at the factory test or at KSC for KSC developed hardware.

2. Configuration Control

- a. Establishing and controlling configuration of KSC developed launch facilities and ground support equipment at each stage of preparation or test at the factory, test site or at KSC.
- b. Maintaining configuration control of MSC and MSFC developed hardware and software after delivery to KSC in accordance with the configuration requirements established by MSC and MSFC. Assuring that prior approval is secured from MSC and MSFC before any changes in configuration are made in spacecraft, launch vehicle, or associated GSE furnished by MSC or MSFC.
- c. Securing, after the flight readiness test, the prior approval of MSC or MSFC for the replacement of failed parts.
- d. Controlling everything that enters and leaves the spacecraft during checkout at KSC in accordance with the MSC list of acceptable items and materials that may be taken into the spacecraft for checkout and for flight.
- e. Controlling tools, equipment and materials that enter and leave the launch vehicle stages and instrument unit during operations at KSC in accordance with criteria provided by MSFC.

3 Logistics Management

- a. Provide total logistics support planning and management for all KSC equipment. Plan for the utilization at KSC of equipment provided by other design cognizant centers, using the inter-center coordinated support planning provided by those centers.
- b. Provide logistics products and services to meet the valid intent of MHB 7500.1 for KSC designed equipment. Utilize logistics products and services provided by other centers to support equipment under their design cognizance, unless stipulated otherwise in inter-center logistics agreements.
- c. Receive, store, issue and dispose of spare parts for all Apollo Program equipment operated at KSC in accordance with inter-center coordinated plans and directions from the design cognizant centers.
- d. Provide reports of logistics requirements, status and spares consumption as required.
- e. Establish, implement and control a logistics discrepancy reporting system.

4. Test and Checkout

- a. Conducting the assembly, checkout, and launch of flight hardware for Apollo missions and assembly, checkout and operation of required ground support equipment.
- b. Providing control of all personnel participating in test and checkout activities, including representatives from MSC and MSFC, and assuring that personnel attend pre-test briefings and participate in training exercises as necessary to assure personnel safety and proper conduct of the tests.
- c. Providing requirements, specifications and criteria, and procedures for test and checkout of KSC developed support equipment whose performance must be verified for each launch.
- d. Providing test and checkout plans in accordance with MSC and MSFC test and checkout requirements plus any additional KSC test requirements necessary to verify launch facility, Manned Space Flight Network and launch crew readiness or to satisfy range and safety requirements.
- e. Securing MSC and MSFC written approval on test and checkout plans and changes thereto before the plans are approved or implemented.
- f. Developing and providing to MSC or MSFC test and checkout procedures adapted to the KSC environment using as a baseline the development center approved factory test and checkout procedures.

- g. Making final determination that test and checkout procedures are adequate, safe and in accordance with MSC and MSFC test and checkout requirements and test and checkout specifications and criteria.
 - h. Obtaining approval on deviations and waivers from MSC and MSFC concerning test and checkout requirements, test and checkout specifications and criteria and inspection criteria when unable to meet requirements.
 - 1. Determining functional performance and flight readiness of flight hardware and software in accordance with test and checkout requirements and test and checkout specifications and criteria provided by MSC and MSFC except for that which is closed out at the factory and not accessible for inspection or not included in test and checkout requirements for evaluation of functional performance at KSC.
 - j. Determining flight readiness of equipment associated with inflight experiments in accordance with MSC or MSFC (as appropriate) specifications and criteria unless specifically excluded by written agreement with MSC or MSFC.
 - k. Controlling receipt and storage, and assuring flight readiness of all Government Furnished Equipment, other than flight crew personal equipment, which is scheduled for flight and which is not processed to KSC through a contractor responsible to KSC.
 - l. Providing routine trouble shooting and maintenance for MSC and MSFC developed equipment in accordance with MSC and MSFC requirements, specifications and criteria.
 - m. Providing an assessment of the flight readiness of the launch complex, flight hardware and software at the Flight Readiness Review in accordance with Apollo Program Directives.
5. Reliability and Quality Assurance
- a. Providing quality control requirements and inspection criteria for KSC developed hardware for use at the factory, test site and KSC.
 - b. Conducting audits to evaluate contractor factory and test site performance in accordance with KSC quality control requirements and inspection criteria for KSC developed hardware.
 - c. Determining corrective action and disposition of KSC developed hardware which fails, malfunctions, or performs outside the performance limits contained in test and checkout specifications and criteria during checkout at KSC.

5 AUG 1968

- d. Generating approval from the appropriate development center (MSC or MSFC) to disassemble or open any flight hardware closed out at a factory or test site.
- e. Securing MSC and MSFC written approval of quality control plans insofar as development center responsibilities are concerned before the plans are approved or implemented.
- f. Conducting quality control inspections and audits of contractor activities at KSC and inviting MSC and MSFC participation as applicable.
- g. Obtaining approval from the appropriate development center (MSC or MSFC) to disassemble or open any flight hardware closed out at a factory or test site.
- h. Advising MSC or MSFC of any problem arising during prelaunch preparation concerning flight worthiness of flight hardware.
- i. Conducting failure analysis as required by MSC and MSFC.
- j. Participating in MSC and MSFC flight hardware acceptance reviews and providing recommendations to MSC or MSFC and the Apollo Program Director, concerning the acceptance of the hardware for shipment to KSC.

6. Systems Engineering

Providing KSC representation on design and operations inter-Center panels or working groups as established by Apollo Program Directives.

7. Operations

- a. Identifying KSC operational support requirements according to approved procedures and evaluating implementation of support planning.
- b. Providing data to MSC and MSFC in accordance with approved Program Support Requirements Documents.
- c. Conducting launch operations.
- d. Developing launch plans and rules.

8. Flight Crew

Coordinating and directing astronaut activities during the time they are actively participating in KSC tests of flight hardware except that the flight crew may take any action necessary for their safety.

Science

None

OFFICE OF MANNED SPACE FLIGHT PROGRAM DIRECTIVE	M-D MA 1400,000 (Project)	DATE 5 AUG 1968
--	------------------------------	--------------------

10. Management

This section contains general management responsibilities for the conduct of the Apollo program at KSC as well as some specific management requirements which need to be highlighted.

General

- a. Assuring that Apollo program requirements for manpower or for institutional support from other elements of KSC are properly conveyed to those elements and that Apollo program institutional support requirements are reflected in Center resource requirements plans, schedules, and budgets.
- b. Assuring that Apollo program requirements for institutional support are met on an effective and timely basis.
- c. Providing control of all activities of Apollo contractors at KSC other than those directly associated with astronaut training.
- d. Developing and operating Center facilities required for the Apollo Program.
- e. Developing and implementing adequate security procedures.
- f. Establishing detailed schedules (Levels 2, 3 and 4) for KSC hardware, software and associated equipment consistent with the basic schedules (Level 1) approved by the Director, Apollo Program and the Director, Mission Operations.

Medical

Medical support for the Apollo program will be provided in accordance with NMI 8900.1. In addition, the following specific requirement will be met on the Apollo program.

- a. Providing for the development and implementation of medical disaster plans associated with the assembly, checkout and prelaunch operations of Apollo flight hardware at KSC.

Safety

Safety activities in the Apollo program will be conducted in accordance with instructions provided by the Apollo Program Director and directives issued by the Manned Space Flight and NASA Safety Directors. In addition the following specific requirements will be met on the Apollo program.

- a. Performing as the NASA single point of responsibility for safety in the Merritt Island and Cape Kennedy area and for NASA range safety inputs to the Eastern Test Range.
- b. Developing criteria for determining hazardous operations at the launch site and securing written approval of MSC and MSFC.

V. PRECEDENCE

This Directive takes precedence over any inter-Center agreements on Apollo program responsibilities.

VI. CONCURRENCE

This Program Directive has been reviewed and concurred in by the Associate Administrator for Manned Space Flight and the Associate Administrator for Organization and Management. Any proposed substantive changes in the responsibilities defined in this document will be submitted for review and concurrence in the same manner.

PROGRAM MANAGEMENT CONTINUITY

The Panel considered the question of continuity of experience in certain key positions at MSC, KSC, NR-Downey, and Beech, and found that it has been good.

At MSC, three different men have held the Subsystem Manager position for the cryogenic gas storage subsystem since November 1963. The first held the position for nearly 3 years during the later design phases and through most of the oxygen tank development period. The second Subsystem Manager was in the position from 1966 through 1968 and was then succeeded by the present incumbent, who had been his assistant.

In the MSC ASPO, there have been five Program Managers, two during the design and development of the oxygen tank. Additional continuity in this position was provided from 1961 through 1966, by the fact that the first Program Manager became the Deputy Program Manager in 1962 and served in that position, under two successive Program Managers, through 1965. In 1967, when the Program Manager next changed, the position was taken by the then Deputy Director of the Center, who had been associated with the Program from that position. The present Program Manager, who took over last year, had been an astronaut with detailed familiarity with the manned space flight program since 1962.

At KSC, the persons with principal responsibility for the test, checkout, and launch of all Apollo spacecraft are the Director of Launch Operations and, reporting to him, the Director of Spacecraft Operations. Continuity in these positions has been good. The present Director of Launch Operations was the Deputy Director for the prior 2 years, approximately. Before that he had been the head of the MSC Resident Apollo Spacecraft Office at KSC. The present incumbent of the Spacecraft Operations position has occupied that position for 5 years. Prior to that time he served as the Assistant Manager for Gemini, MSC Florida Operations.

At North American Rockwell the position with direct responsibility for overseeing design and manufacture of the cryogenic gas storage system (CGSS) by the subcontractor, Beech, is the Manager, Fuel Cells and Cryogenic Systems (fig. E4-10). The present incumbent of that position has held it since 1962 and has been NR-Subsystem Manager for the Apollo CGSS over that entire period. The present Apollo Program Manager at NR succeeded to that position last year when the former Program Manager was appointed NASA Associate Administrator for Manned Space Flight. Prior to his promotion, the present Program Manager had been the Assistant CSM Program Manager for about 4 years.

At Beech-Boulder Division, the same men have occupied one or another of the key positions in the CGSS contract to NR over the life of the contract. There has been turnover in manufacturing personnel at the technician and trades levels but the principal managers and supervisors have not changed. It is noteworthy that when members of the Apollo 13 Review Board visited Beech for a demonstration of the assembly of an Apollo oxygen tank, the technician who performed the assembly demonstration was the same man who had assembled Apollo 13 tank no. 2 in 1966.

This page left blank intentionally.

PART E6

APOLLO SPACECRAFT PROGRAM MANAGEMENT SYSTEMS

The various organizational relationships and the management philosophy for Apollo are defined in reference 1. This document defines the relationship and functioning of the various organizational elements which have been described in Parts E4 and E5 of this Appendix. In addition, there are several other documents which provide implementing details concerning the management control systems and their intended operation.

A general understanding of the management systems which are being used and their relationship to the program progress is helpful in determining or appreciating the extent of the review which is applied to all phases of the program throughout design, manufacturing, test, checkout, and operation.

It is also considered important to recognize that some of the review and control systems are primarily concerned with the entire scope of a module program and that others concentrate on individual modules by serial number.

The systems which have been implemented by MSC are generally similar for both the CSM and the LM. Due to the nature of this review, the CSM only is considered and all subsequent reference to a vehicle means the CSM or more particularly the service module.

There are three management systems which directly impact all CSM's at various points in time:

- (a) Design Reviews
- (b) Configuration Management
- (c) Readiness Reviews

Throughout the entire management process the Reliability and Quality Assurance system maintains a continuing surveillance of all problems.

DESIGN REVIEWS

The contractor initiates the design phase of the contract based upon the general specifications and the performance requirements established by the ASPO. These requirements and broad specifications are developed by the MSC technical organization and approved by the ASPO prior to the contractor initiating activity.

Preliminary Design Review

The general requirement is for a Preliminary Design Review (PDR) to be conducted on the CSM when the design concept has been determined by the contractor and prior to the start of detail design. The ASPO Systems Engineering Division normally organizes and conducts these reviews which are chaired by the Apollo Spacecraft Program Manager. Various subsystems may reach a design concept stage earlier than others and a series of PDR's may be conducted. The result of the PDR is to establish the design requirements baseline from which engineering control can be exercised. Upon the completion of the review, the ASPO manager authorizes Part I of the end-item specification to be inserted in the contract, along with any necessary design modifications.

Critical Design Review

The Critical Design Review (CDR), also organized and conducted by ASPO Systems Engineering Division and chaired by the ASPO Manager, is held when the contractor has released or completed between 90 and 95 percent of the engineering. At this point there is sufficient information for the ASPO and the appropriate subsystem managers to adequately review the engineering and to determine if the objectives of the design concept have been achieved. Again, because the engineering for different subsystems is not all completed at the same time, a series of CDR's may be conducted. At the completion of the CDR a drawing baseline is established and the strict Configuration Control System is implemented.

CONFIGURATION MANAGEMENT

A primary document, in addition to reference 1 which defines the Configuration Management Control System, is the "Apollo Spacecraft Program Configuration Management Manual," (ref. 2). This document details the various change control levels, defines the categories of change, and establishes the membership of the various boards and panels which are involved. Figure E6-1 depicts this total relationship among the five change control levels. This document contains the detailed instructions which are necessary to implement the intent of the "Apollo Configuration Management Manual" as modified by the MSC Supplement No. 1 (ref. 3).

As shown by figure E6-1, there are actually five functioning levels of change control for the CSM. The Configuration Control Board (CCB), Level II, is responsible for the CSM, LM, and affected subsystems.

The Chairman of the CCB is the Apollo Spacecraft Program Manager; and the ASPO Managers for CSM, LM, the Experiments and GFE, the Assistant Program Manager for Flight Safety, and the MSC Directors of the

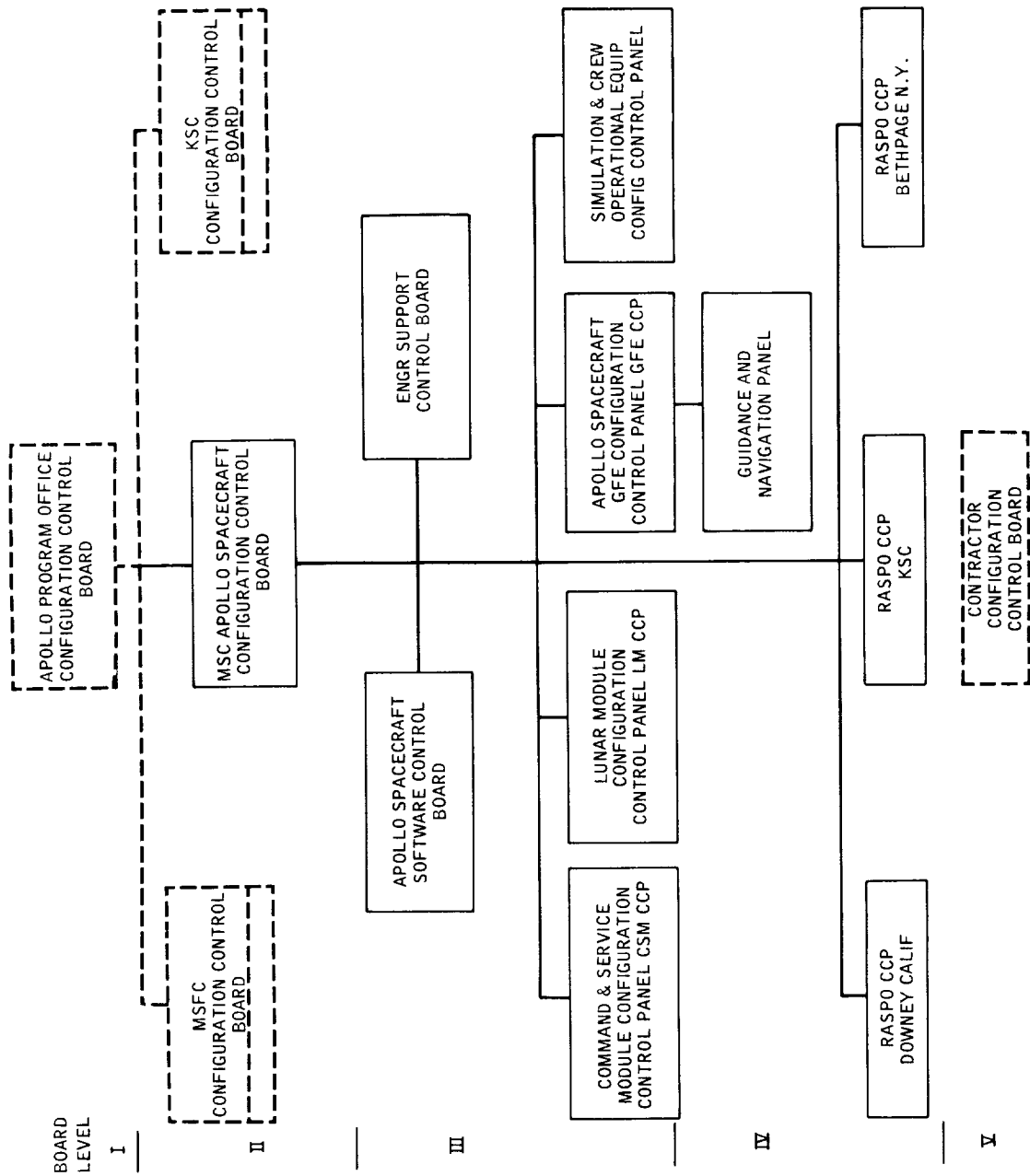

Figure E6-1.- Configuration Control Boards - Apollo Spacecraft Program.

five technical Directorates are principal members. The CCB is responsible for approval or disapproval of changes in the following major categories:

- (a) Changes which affect an interface among two or more Configuration Control Panels (CCP).
- (b) Changes which affect spacecraft mass properties.
- (c) Change resulting in contract cost increases in excess of \$300,000.
- (d) Changes which affect end-item delivery dates.

It should be noted that change control is established for more than merely hardware or specification baselines. Also included are software items, such as mission timeline, math models, consumables, and schedules.

Configuration Control Panels (CCP) are established at Level III by the authority of the CCB Chairman and are designated as the approving authority for all Class I changes not designated for CCB action. Class I changes are defined in general as those affecting the specification, performance, cost, quality, safety, or interchangeability. Configuration Control Panels are established for the CSM, LM, and GFE. The CSM CCP is chaired by the ASPO Manager for CSM. Panel membership is obtained primarily from the same organizations as indicated for the CCB; however, the members are Division Chief level or designees rather than Directors.

The Level IV CCP is at the Resident Apollo Spacecraft Program Office (RASPO) at Downey. This panel is chaired by the Resident Manager. Generally, the panel can approve changes which concern test procedures but not hardware configuration. An exception to this is made during final checkout of a specific vehicle or during field test or launch preparation. These are classed as compatibility or make-operable changes, are restricted to single modules only, and must be reported to the CSM CCP within 24 hours.

A fifth level of change control exists because all changes whether Class I or Class II must go through the North American Rockwell (NR) CCB. This board is chaired by the NR Program Manager. It approves all Class I changes for submission to the appropriate NASA authority as previously defined and has the authority to approve Class II changes for implementation. The definition of Class I and Class II changes is that contained in ANA Bulletin 445 (ref. 4) which is considered to be a standard reference. Some subsequent modification of ANA 445 occurred during the course of the NR contract. However, the effect of these modifications or clarifications

was to make the procedures and definitions more restrictive. It is noted that all Class II changes which are approved by the contractor are submitted to the RASPO for information. This provides an opportunity for review. Also, the NR control system is such that each Class II item is picked up and reported to R&QA. Class II changes include those not defined as Class I.

Although the CCB may be concerned with a change to a specific vehicle, in most instances the changes involve all of the remaining vehicles to be manufactured or which have not flown. That is, a major part of the effort of the CCB is devoted to assuring that the overall configuration is appropriate and that the procedures are compatible with all elements of the system. In general, the CCB is concerned about the configuration of the basic CSM. Readiness Reviews, which are discussed in the following section, are concerned with the exact configuration of a specific CSM.

With regard to subcontracts like that for the oxygen tanks, there is actually an additional level of configuration control by the Beech Aircraft Corporation. Their Configuration Control Board reviews all changes, both Class I and Class II. Class I changes are sent to NR for processing through the system and Class II changes may be approved by Beech for implementation. In actual practice there are only a few Class II changes and all of these are sent to NR for information and recorded in the system.

READINESS REVIEWS

The Readiness Reviews are conducted for each specific vehicle. These reviews are concerned with the manufactured subsystems that have been assigned to a specific CSM.

Customer Acceptance Readiness Reviews

The basic objective of the Customer Acceptance Readiness Review (CARR) is to evaluate the readiness of the CSM for delivery to KSC for launch preparation. The CARR Plan for Apollo command and service modules was revised in January 1969. This plan is referenced in the Apollo Spacecraft Program Configuration Management Manual (ref. 2) and has generally been applicable throughout the Apollo Program. The plan defines the detailed requirements for preparation of documentation, subsystem reviews, items for review and general procedures. Definition of the review teams, their composition, function, and tasks are also contained in the CARR Plan.

A complete CARR for a specific CSM is conducted in three phases:

(a) Phase I - To be conducted by the ASPO immediately prior to the initiation of installed subsystem checkout of the assembled CSM to identify constraints of subsystem tests. This includes firm identification of constraints to system tests.

(b) Phase II - This phase was a formal review until changed by ASPO letter of January 28, 1969, which authorized the RASPO-Downey to approve the start of CSM integrated test by the contractor.

(c) Phase III - Conducted by the Director, MSC, immediately prior to shipment to identify constraints to acceptance/shipment. It is a review of additional data from Phase I.

Systems Summary Acceptance Documents (SSAD) are compiled and used by Government and contractor subsystem review teams in the Phase I CARR. There are 44 of these documents prepared to cover the subsystems contained in the launch escape system, command module, service module, and the spacecraft-LM adapter (SLA). Of these, 14 involve the service module (SM) and there are separate documents for the environmental control system and the electrical power system and wiring, which include the cryogenic oxygen tanks.

SSAD books become the complete and official historical documents for each specific CSM subsystem. Included in the books are specific signed statements from both the responsible contractor engineer and the NASA Subsystem Manager certifying the readiness of the specific subsystem for the particular phase which is being reviewed.

The Phase III CARR is concerned only with documented changes since Phase I. This concept provides a means of concentrating on only those items which are different from the last review and avoids the effort which would be necessary to conduct each review from the beginning of the CSM history.

At the completion of the Phase III CARR, the CSM is ready for shipment to the KSC.

Flight Readiness Reviews

A Flight Readiness Review (FRR) for the CSM, LM, and GSE is conducted at MSC. In general, this review is similar to the review described in the CARR plan. The same systems are reviewed by similar review teams and the SSAD books are continued. However, now there are additional items added due to the inclusion of the ground support equipment and the

SLA. Primary continuity is obtained by use of the SSAD books, their updating during the formal FRR and subsequent special tests.

An FRR Data Review is held at KSC to prepare for the formal FRR Board meeting at MSC. The FRR Board is chaired by the Director of the MSC or his deputy and includes key management personnel from NASA Headquarters, MSC, and KSC. The review objectives are to determine any action required to bring the CSM/LM/GSE to a condition of flight readiness.

The final FRR is conducted by the Office of Manned Space Flight at KSC approximately 5 weeks before the scheduled launch. This FRR is chaired by the NASA Headquarters Apollo Program Director and includes review of all elements of the mission.

Launch Minus 2-Day Review

This review is chaired by the Apollo Mission Director with all the senior manned space flight officials in attendance. This review is held to review all elements of the mission and to assure closeout of all items since the final FRR.

LAUNCH CHECKOUT PROCEDURES

As shown by figure E6-2, technical control of the hardware remains with MSC during the checkout and test operations at KSC. However, the KSC is specifically responsible for conducting the tests and for developing appropriate test procedures to fulfill the test requirements established by MSC.

A Test Requirements Document is prepared and approved by MSC (ref. 5). This document specifically defines the following:

1. Test Constraints - the test sequencing which must be completed prior to accomplishment of particular test requirements and any specific test constraints.

2. Primary Mission Test Requirements Matrix - matrices are listed by system, identifying mandatory test requirements that must be satisfied during the course of spacecraft checkout at KSC. Indication is given of the GSE and facility locations and the desired test guidelines are referenced.

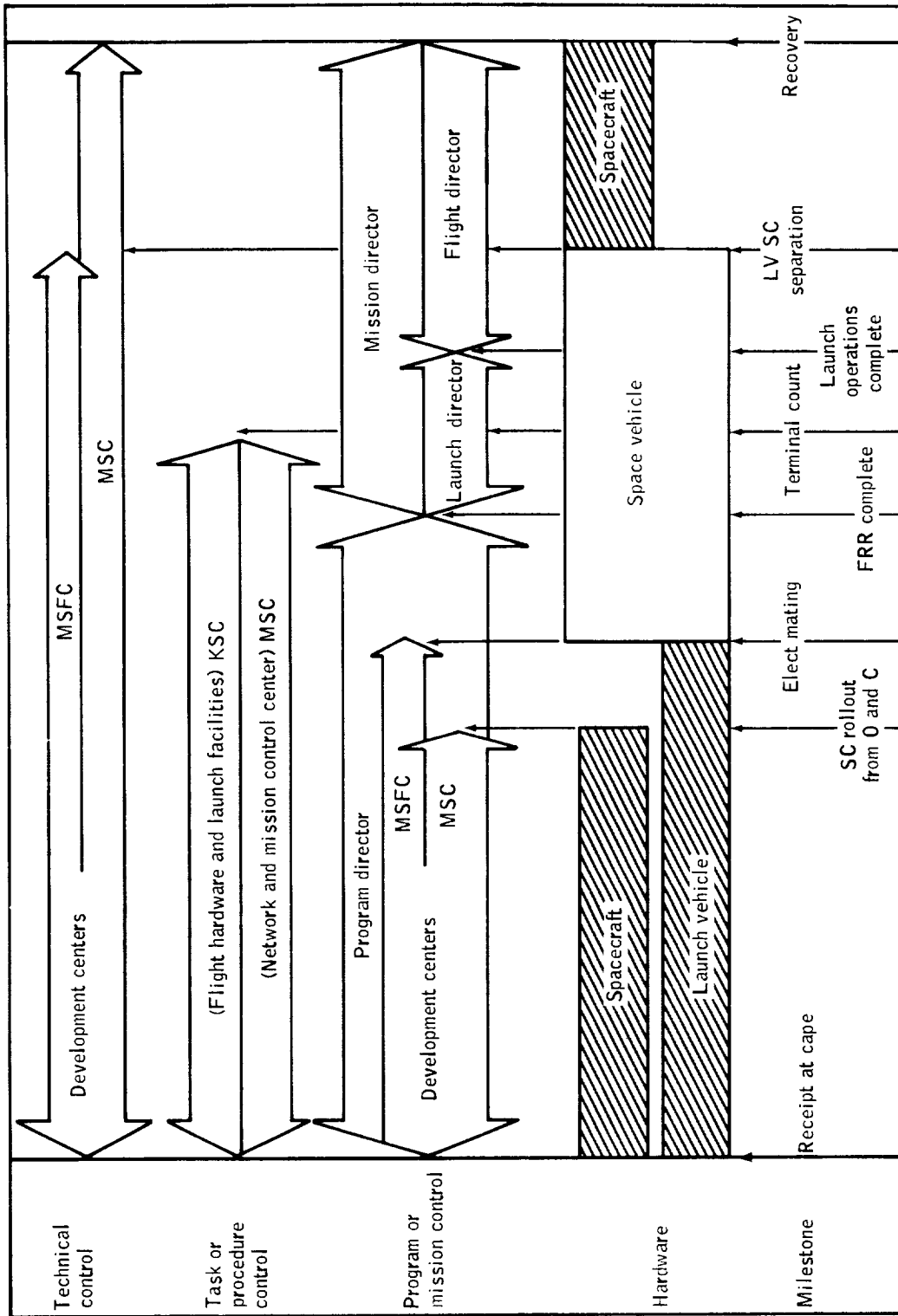

Figure E6-2.- Mission responsibility relationships.

3. Retest Requirements - the general requirements for spacecraft or GSE reverification in the event of test invalidation because of equipment removal, disconnecting, repair, etc.

4. Contingency Test Guidelines - requirements.

5. Safety Requirements.

6. Test Guidelines - these specific sheets reflect the desired test contents, objectives, and test prerequisites.

7. Alternate Mission Test Requirements - matrices are identified for the mandatory test requirements that must be satisfied if a CSM is designated to perform an alternate mission.

Upon receipt of the Test and Checkout Requirements Document from MSC, KSC prepares a Test and Checkout Plan. This plan contains the outline for accomplishing the test requirements defined by MSC at the launch site and additional tests which the KSC considers necessary to verify launch facility, manned space flight network, and launch crew readiness or to satisfy range safety requirements. The Test and Checkout Plan (TCOP) is the master test document and is approved by both KSC and MSC. Changes to this plan and also changes to the facility are reviewed and approved by the KSC and MSC.

Based on the TCOP, detailed Test and Checkout Procedures (TCP) are prepared and approved by KSC. These are the implementing documents which assure that correct detailed information is available prior to the conduct of any test. Changes to these procedures are processed on controlled change request forms which are signed by the appropriate authority. The details for preparation, release, and execution of the TCP are contained in Apollo Preflight Operations Procedures No. 0-202 and 0-221.

Test deviations which may be necessary just prior to the start or during the test are authorized. However, the deviation must be fully documented. Review in this case takes place after the completion of the test, but it is still reviewed and the appropriate levels of authority are provided with the opportunity to modify, change, or to have the tests rerun.

Approximately 2 weeks prior to the scheduled launch date, two separate countdown demonstration tests (CDDT) are conducted. The first of these, called the "wet" CDDT, involves the booster and tanking of all cryogenic systems in all modules. This countdown runs to a simulated lift-off and is then concluded.

A second, or "dry," CDDT is conducted shortly after the "wet" CDDT. This CDDT is primarily concerned with the crew functions. The cryogenic tanks are partially detanked during this CDDT.

The results of the CDDT, "wet" and "dry," are reviewed by the Mission Director and the decision is made to initiate the final countdown. A final review is conducted with all of the senior Manned Space Flight officials at the Launch Minus 2-day Review. At this point the mission is firmly committed.

PART E7

OXYGEN TANK MANAGEMENT REVIEW

GENERAL TANK HISTORY

This part will review the management process described previously as applied to the design, production, test, and checkout of the cryogenic gas storage system oxygen tank.

North American Rockwell (NR) established tentative requirements for a cryogenic gas storage system and issued a request for proposal to interested companies in the spring of 1962. In the summer of 1962, Beech Aircraft Corporation was awarded a letter contract to design, develop, and qualify the Block I Apollo cryogenic gas storage system. This contract was awarded after evaluation of the proposals from Beech and a number of other companies with cryogenic experience. The original contract for Block I was scheduled to be completed by January 1964, and was covered by NAA Specification MC 901-0005 (ref. 6).

A considerable amount of the early effort was expended in development of a spherical heater pressurization system which was both heavy and electrically complicated. In late 1963, a program was established to design an alternate cryogenic fan motor and heater system which was developed and approved for production early in 1964.

The primary vendors for Beech on production hardware were Parker Aircraft for valve modules; Cameron Iron Works for oxygen tank Inconel forgings; Globe Industries, Inc., for the tank motor fans; Simmonds Precision Products, Inc., for instrumentation; Airite Division of Sargent Industries for pressure vessel tank welding; and Metals and Controls Corporation for the tank heater thermal switches.

In 1964, the state-of-the-art for insulation of supercritical oxygen tanks was thoroughly investigated and an improved concept using dexiglass paper and aluminum foil was tested and found satisfactory. Also, the boilerplate BP-14 tanks were completed and shipped to NR in 1964.

Block II competition was held in early 1965, and Beech was awarded this contract in October 1965. Beech made delivery of the first Block I tank in December 1963, and the last one in 1966. There was therefore some overlap of these contracts.

Preliminary Design Reviews were held in May and July of 1965 by NR and Beech. A Program Review was held in December 1965 for the MSC

Apollo Spacecraft Program Manager. Because of the tight delivery schedule, it was decided at the Program Review to assign an NR team to Beech to assist in assuring meeting tank delivery schedules. The configuration control baseline was established by the Critical Design Review held in March 1966 attended by NASA, NR, and Beech representatives. The first Block II oxygen tanks were delivered in July 1966. A First Article Configuration Inspection (FACI) was conducted November 16-18, 1966, with NR, Beech and NASA participating. The FACI confirmed the configuration baseline.

The original specification (ref. 6) from NR to Beech for procurement of the oxygen tank and heater assembly was dated November 1962. No reference is made in this specification to other than design for 28 V dc. Beech issued a specification in 1963 to Metals and Controls Corporation for procurement of the thermal switches for the tank heater assemblies. These thermal switches were to limit the tank temperatures and prevent overheating and were built to interrupt the 28 V dc spacecraft current. The heater GSE was subsequently designed and built by NR with a 65 V dc power supply for use at KSC in initial pressurization of the oxygen tanks. The 65 V dc current was used in order to pressurize the oxygen tank more rapidly than could be done with the 28 V dc spacecraft power supply. NR issued a revised Block II specification (MC-901-0685) to Beech in February 1965 which specified that the oxygen tank heater assembly shall use a 65 V dc GSE power supply for tank pressurization.

Beech issued a specification (14456) in July 1965 to Metals and Controls Incorporated for the thermal switches for the Block II tanks. This revised Beech specification did not call for a change in the thermal switch rating in order to be compatible with the 65 V dc GSE power supply. (The thermal switch, which remains closed in the cold liquid oxygen, will carry the 65 V dc current but will not open without damage with 65 V dc applied.)

NR or Beech never subsequently caught this discrepancy in the GSE and thermal switch incompatibility. The incompatibility had not caused problems previous to Apollo 13 since the thermal switch had never been called upon to open with 65 V dc applied. The extended heater operation using 65 V dc GSE power during the March 27 and 28 detanking at KSC raised the tank temperature to 80° F and called for the thermal switches to open for the first time under these conditions (for which they were not designed or tested). The switch malfunctioned and during the subsequent operation did not provide the tank overheating protection which the KSC test personnel assumed existed.

During the development cycle the following technical problems were encountered.

Tank Vacuum and Heat Leak Problems

Poor vacuum, difficulty in acquiring good vacuum on initial pump-down, and degradation of vacuum from outgassing under vibration were encountered early in the program. These resulted in a high heat leak and caused excessive rates of flow and pressure rise. Early failures to attain satisfactory initial vacuum, including two on qualification tests, were corrected by revisions to test procedures to extend the heat leak stabilization period and upgrade methods of vacuum acquisition.

Vacuum pumping equipment was also modified and improved. A specification change was approved by NR to permit an adequate but more realistic value of heat leak.

Design changes were made in order to correct continued difficulty in securing and retaining good vacuum, and vac-ion pumps were incorporated as an integral part of the tank assembly. Use of the vac-ion pump prevented further gross degradation of vacuum from outgassing. Part of the heat leak was attributed to variation in density of the load bearing insulation in the tank annulus. The insulation was redesigned to reduce the allowable weight and control the overall density of the insulation.

Heat leak did, however, remain slightly over specification on some tanks, and these minor deviations were waived.

Fan Motors

The fan motors for the cryogenic oxygen experienced a number of failures during their production history. A review of these motors was conducted by Globe Industries, Inc., and Beech Aircraft Corporation. The report was issued in January 1967.

The complete manufacturing, handling, and usage of the fan motors at Globe, Beech, and NR was reviewed and the failures that had occurred were grouped in the following nine failure classes:

1. Contamination failures
2. Bridge ring failures
3. Bearing failures
4. Phase-to-phase shorts
5. Grounds

6. Leadwire damage
7. Speed
8. Coastdown
9. Miscellaneous

Other failures, including tolerance build-ups, were reported which could not be classified in the other groups. These are listed under the miscellaneous classification. The corrective actions taken as a result of this review significantly reduced the number of failures. One apparent flight failure in an oxygen tank fan motor occurred on Apollo 6. The failure was analyzed as a single-phase short to ground in the heater fan motor circuit. Subsequently, the circuit was revised to include individual fuse protection for each motor and single-phase circuit breakers in each phase.

Vac-ion Pump and Electromagnetic Interference (EMI) Problems

During qualification test there was arcing to the vac-ion pump harness at a mounting screw. Increased clearance was provided. A continuity check was added to verify wiring. Dielectric leakage between the pump and the tank shell also occurred at the vendor plant. A design change was incorporated adding insulation spacers to provide increased clearances, with satisfactory results.

The use of the vac-ion pump led to EMI with other systems on the spacecraft. Corona discharge and arcing of the high voltage lead and connector occurred. This was identified during altitude chamber test of spacecraft 101 at KSC. The fix initiated was to modify the shielding of the high-voltage lead and improve the potting in the connector.

The vac-ion pump is normally not used during flight. It has only been used during vehicle assembly and checkout to assure that the proper vacuum is maintained on the oxygen tank annulus. The circuit breakers for these pumps are opened prior to flight.

Heater Failures

Electrical shorting in the heater circuit occurred twice. A heater element caused a short during acceptance test of a Block I tank at the vendor's plant. A circuit breaker tripped 20 minutes after power was applied. The short was caused by damage to the insulation of the heater lead wires. It was apparently scraped during installation of the wires into the tank or during handling prior to installation. Improved inspection and installation procedures and a pin-to-pin insulation

resistance test were initiated. During qualification testing the heater lead wire was burned and a circuit breaker was tripped by overload. The cause was faulty solder joints made during installation. Improved fabrication techniques were put in effect, and applied to all Block II tanks.

During this period of design, development, test, and manufacture, there had been coordination meetings of Beech personnel with the NR and NASA representatives. By the end of 1966, the tanks had completed the major cycle of development and qualification and about 30 tanks had been delivered. In 1967, 17 additional tanks were delivered, three were delivered in 1968, and six were delivered in 1969. These deliveries essentially completed the contract except for eight tanks remaining at Beech. In addition, 11 tanks were used during the early development period for qualification and tests, making 75 tanks in all. Of these 75 tanks, 28 were in Block I and 47 in Block II.

CHRONOLOGY OF APOLLO 13 OXYGEN TANK

The specific tank assembly of interest in this review is oxygen tank no. 2 of CSM 109. This tank is identified as ME 282-0046-008 serial number 10224XTA0008. The other tank on the oxygen shelf of CSM 109 was serial number 10024XTA0009.

The end-item acceptance data package (ref. 7) contains the configuration and historical data relative to this particular tank. Using these data and pertinent spacecraft review data, it is possible to trace this tank through its manufacture, reviews, discrepancies, and tests to launch as a part of an approved flight system.

The Cameron Iron Works made a rough forging of top and bottom tank hemispheres in accordance with Beech specifications and provided the required microstructure analysis of the grain size of the Inconel 718 hemisphere and evidence of satisfactory ultrasonic and radiographic inspection. The forgings were shipped to the Airite Division of Electrada Corporation, El Segundo, California, for machining and welding. After machining, pressure vessel wall thickness measurements were made on the upper and lower hemispheres at about 300 points to establish that girth and membrane measurements were within specified tolerances. The two hemispheres were then welded together, X-rayed for weld inspection, and shipped to Beech Aircraft Corporation on June 15, 1966. Beech Aircraft installed the probe, quantity and temperature sensor, furnished by Simmonds Precision Products, Inc., and cryogenic fan motors furnished by Globe Industries, Inc. Beech also installed the tank insulation and outer Inconel shell.

During the manufacture and testing of the tank 0008 at Beech, a number of discrepancies recorded as Material Review Records were reported and corrected. These discrepancies included:

1. The upper fan motor was noisy and drew excessive current. Corrective action was to remove both fan motors and replace them with new motors serial numbers 7C30 and 7C41.

2. The vac-ion pump assembly insulator was found to have two small cracks along the weld bead. Corrective action was to grind off the pump assembly and insulation weld, to remove and replace the insulator and reweld the assembly.

3. During the minimum flow tests, the oxygen flow rate was found to be 0.81 lb/hr as compared to 0.715 lb/hr specified as maximum in the NR specification. A waiver was requested for this and three other tanks that exhibited similar flow rates. Waiver CSM 0044 was approved by Apollo Project Engineering at NR and by the Acting Manager, Resident Apollo Program Office (RASPO) in accordance with standard procedures. The tank was subjected to the specified end-item acceptance check, including vac-ion functional test, heater pressurization test, electrical insulation resistance tests, dielectric strength tests, proof and purge tests, and minimum oxygen flow tests. These tests were all satisfactorily completed, with the exception of the slightly excessive oxygen flow rate previously discussed, and are documented in the End-Item Acceptance Data Package Book (ref. 7).

Handling Incident

The tank was shipped to NR, inspected, and then installed on an oxygen shelf in June 1968. This shelf was subsequently installed in CSM 106. The vac-ion pump modification, previously discussed, could not be performed with the tank-shelf assembly installed in a service module. For this reason, the oxygen shelf was removed from CSM 106. During the removal sequence the shelf handling fixture broke and the shelf was dropped approximately 2 inches. After the modification and appropriate inspections, the shelf assembly was reassigned to CSM 109.

DR's were written to require inspection and test of the shelf assembly for recertification. These inspections and tests revealed no major discrepancies. It was reported by NR that an engineering analysis was performed to determine the forces which might have been imposed on the tanks due to the "shelf drop." This analysis indicated that the loads were within the design limits of the tanks and that no internal damage should have been sustained. This informal report is not now available from existing files.

To verify that the internal components of the tanks were functional, a series of tests were conducted. The tanks were given a repeat of the acceptance and verification tests which are normally conducted by NR prior to installation of an oxygen shelf in a service module. All of these tests were passed successfully, with no significant changes from the previous test results. NR does not fill the tanks with liquid oxygen during their test, assembly, and checkout activities at the plant.

At the completion of the required vac-ion pump modifications and with the successful test results obtained, the shelf assembly condition was reviewed by NR engineering, R&QA, and the RASPO and installed in CSM 109. All appropriate signatures were obtained on the DR's, copies of these were provided to the Subsystem Manager at MSC, and copies were also included in the Subsystem Summary Acceptance Document (SSAD) book for spacecraft 109.

At the Phase I CARR for CSM 109, November 18-19, 1968, the incident was again discussed by the CARR subsystem team with NR engineering and NASA/RASPO. Documents and NR test results were reviewed and the shelf was accepted. It had passed all required tests, the analysis indicated that estimated loads had not exceeded design limits, and the entire record had been properly reviewed. The incident had been explained in accordance with all of the management control systems in effect.

The Phase III CARR on May 26-28, 1969, verified that the shelf was installed in CSM 109 and that test data verified satisfactory oxygen shelf performance in accordance with the test DR written by NR and NASA/RASPO.

The information concerning the handling incident was included in the SSAD books for spacecraft 109. It was not reviewed by the Flight Readiness Review (FRR) Board. Equipment which has successfully passed all tests and has been certified as flightworthy does not require additional reviews unless additional problems are discovered. As no problems were encountered, the CSM 109 FRR on January 15-16, 1970, considered the oxygen shelf checkout as having been satisfactorily performed and recommended the system as flight ready.

Because the handling incident had occurred early in the review cycle for spacecraft 109 and had been closed out, it was not reconsidered in any detail during the decision process regarding the detanking incident. NR personnel at Downey were aware of the handling incident. However, Beech, KSC, and senior MSC Management were unaware of the incident.

The R&QA reporting and data retrieval system is designed to enable records to be readily obtained. However, this is not an automatic action. It is necessary for the concerned people to initiate the action; that is, request the record search. By virtue of the general concept that is applied to Apollo, this search of the records is seldom done. Flight equipment is either flightworthy or not. There is no gray area allowed between good and bad equipment.

Detanking Incident

After shipment to KSC, build-up checkout activities proceeded normally until the countdown demonstration test (CDDT) sequence wherein the tanks were pressurized, checked, serviced with liquid oxygen, and then detanked. Detanking difficulty developed during sequence 29-009 of Test and Checkout Procedures (TCP), TCP-K-0007V2, at 10:55 p.m. on March 23, 1970, when oxygen tank no. 2 did not decrease to about 50 percent quantity as expected.

The problem was first attributed to a faulty filter in the associated ground support equipment (GSE) and an Interim Deficiency Report (IDR 023) was initiated for evaluation of the filter.

Troubleshooting of test sequence 29 was continued by the NR Systems Engineers, the NASA (KSC) Systems Engineers, and the NR Systems Specialist with the actions monitored by a KSC reliability specialist and a KSC safety specialist in accordance with specified KSC procedures.

A decision was made on March 23, 1970, at 11:37 p.m. that TCP-K-0007V2 test procedures could be continued. This decision was made by the NR Systems Engineer, NASA (KSC) Systems Engineer, and the NR Systems Specialist.

TCP-K-0007V2 was continued through sequence 29-014 by 2:55 a.m. on March 24, and the IDR 023 was upgraded to a GSE/Discrepancy Report (DR) for filter evaluation on March 24, 1970.

The TCP-K-0007V2 test sequence 29 was reinitiated on March 27, 1970, at which time it was known that the suspect GSE filter was not malfunctioning. An Interim Discrepancy Report (IDR 040) was written to investigate detanking and change detanking procedures to assist in detanking. After substantial time was spent in the detanking attempt, the IDR 040 was changed to a spacecraft DR 0512.

A conference including MSC subsystems engineers and KSC Apollo CSM Manager was held and a Beech engineer was contacted by telephone to discuss the problem. It was decided that the difficulty was caused by allowable looseness in a fill line fitting and it was decided to try detanking using fans and heater on oxygen tank no. 2. This was started on March 27, 1970, during the second shift.

DR 0512 was signed by the NR Systems Engineer, the NASA Systems Engineer, and the NR Systems Specialist (all of whom are assigned to KSC), and varied the procedures of the basic TCP. This variation did not result in satisfactory detanking.

DR 0512 was further amplified on March 28, 1970, at about 4 a.m., to provide for a pressure pulsing technique whereby the tank vent was closed and the tank was pressurized to 300 to 340 psig, allowed to stabilize for 5 minutes, and then vented through the fill line. This procedure was concurred in at the time by NR Systems Engineer, NASA Systems Engineer, NR Systems Specialist, and NR Systems Manager, all of whom are assigned to KSC. This procedure was followed for five pressure cycles and the tank was emptied.

The decision to be made by KSC in consultation with NR and MSC was whether to leave the oxygen shelf in the spacecraft or to exchange it for a different one. This was a critical decision because changing a major unit such as the oxygen shelf at the KSC is not a normal practice. It can be accomplished, but it must be done manually at some risk of damage to adjacent components. At the NR factory, there is a specifically designed item of GSE with which to remove the shelf.

Many telephone calls were made concerning the detank problem, and several of them were conference hookups so that most of the participants could hear the entire conversation. The KSC Director of Launch Operations and the MSC Apollo Spacecraft Program Manager led the ensuing investigation which included key technical experts at Beech, similar experts at NR, and the subsystems managers at MSC.

During the weekend beginning March 27, MSC developed a comprehensive checklist of questions which had to be answered prior to making a decision concerning the oxygen tank:

1. Details and procedures for normal detanking at Beech and KSC.
2. Details of abnormal detanking at KSC on March 27 and 28.
3. Hazards resulting from a possible loose fill tube in the oxygen tank.

4. Can the tank be X-rayed at KSC?
5. Could loose tolerances on the fill tube cause the detanking problem?
6. Should a blowdown and fill test be made on the tank?
7. Disassemble both oxygen tanks from Service Module 2TV-1 and examine components.

All of the checklist questions were answered by test, analysis, and inspection. The report of the Beech investigation, contained in reference 8, included the following conclusions:

1. "Based on manufacturing records, the Teflon tube fill line assembly was installed.
2. Total gap areas in the assembly after cooldown could vary from 0.004 in² to 0.09 in² from tank to tank.
3. Based on allowable tolerances, gap areas on tanks could approach the area of 3/8 inch fill line, thus accounting for the inability to detank per methods used at KSC.
4. Normal stresses on the Teflon plug are not sufficient to cause cracking or breakout of the plug.
5. The assembly, fabricated to print dimensions, cannot come apart in the installation.
6. Tank X-rays are not clear enough to show the fill assembly.
7. The delta pressure across the coil assembly and disconnect is very small.
8. Energy level developed by shorting capacitance plates on probe is too low to cause a problem."

In addition to these conclusions, Beech also provided NR a copy of their detanking test procedures and the calculations used to reach their conclusions.

Based upon the Beech information, the condition of the 2TV-1 oxygen tank fill line determined by direct inspection and the understanding that the detank procedures at the KSC and at Beech were different, it was concluded that the tank was flightworthy. The primary participants

in reaching this conclusion were the NR CSM Program Manager, the KSC Director of Launch Operations, and the MSC ASPO Manager. The fact that these people did not have complete or correct information to use during the decision process was not determined until after the accident.

The information which subsequent review determined to be incomplete or incorrect included the following:

1. Neither the KSC Launch Operations Director nor the MSC ASPO Manager knew about the tank handling incident which had occurred at NR-Downey.

2. The last portion of the detanking procedure at Beech is similar to that used by KSC. No one appeared to be aware of this similarity between the procedures. At one time during the early portions of the program they were, in fact, different.

3. All of the key personnel thought that the oxygen tank on Service Module 2TV-1 had experienced detanking problems similar to those experienced at KSC. As this tank was available, it was disassembled and inspected. The examination of the internal tank parts showed a loose-fitting metal fill tube and it was concluded that this loose fit was the cause of the detanking problem. Subsequent review has revealed that the 2TV-1 tank probably detanked in a normal manner.

4. The senior managers were not aware that the tank heaters had been left on for a period of 8 hours. It appears this information was provided to NR-Downey by telephone during a long conversation. However, it was not considered during the decision process. No one at MSC, KSC, or NR knew that the tank heater thermostatic switches would not protect the tank from overheating.

The management system alerted the right people and involved them in providing technical information to the responsible program managers. Communications were open, unrestricted, and appear to have been nearly continuous. All of the modified KSC detank procedures were correctly documented and other reports were correctly filled out. The problem was that inaccurate and misleading information was provided to the managers.

Any consideration of whether management decisions would have been different if the correct data had been provided is highly speculative. However, it is likely that requests for additional tests or data may have been considered during the discussion if the correct information had been available.

This page left blank intentionally.

PART E8

OXYGEN TANK MATERIAL SELECTION

The original design of the cryogenic oxygen storage system was based on state-of-the-art existing in 1962 and subsequent developments during the course of the contract test and evaluation phase. The tank contractor, Beech Aircraft, Boulder, Colorado, started the design using materials considered compatible based on existing cryogenic knowledge. A limited program was followed in qualifying components, such as the Globe fan motors in the company's test facilities.

The first formal application of Nonmetallic Materials Selection Guidelines was imposed on NAA by CCA 1361 dated April 17, 1967. This Change Authorization required that the contractor implement ASPO-RQTD-D67-5A dated April 17, 1967, and recommend a detailed plan for analysis, application testing, selection, and approval of nonmetallic materials to assure that all potentially combustible applications are identified and controlled. In addition, the contractor was required to recommend any design and/or material changes necessary to meet these criteria. This change was effective on Spacecraft 2TV-1, 101, and subsequent.

The cryogenic oxygen gas storage system was categorized as Category D--Material Applications in High Pressure Oxygen System--for material selection and control purposes.

Requirements for Category D are as follows: This category shall include those materials used in greater than 20 psia oxygen systems. Materials shall have prior use history in oxygen service, with no fire or explosion experience.

FUNCTIONAL DESCRIPTION

Materials for such applications as filters, seals, valve seats, and pressure bladders shall be covered by these criteria.

Material Property Requirements

Propagation rate.-- No test required.

Thermogravimetric analysis and spark ignition test, reference 9.-- This test is designed to determine the weight loss and outgassed vapor spark ignition characteristic of materials under test. A material evolving significant vapors verified by weight loss and having a visible flash at a temperature less than 400° F is unacceptable. A material that shows

evidence of charring or sustaining combustion at a temperature less than 450° F is unacceptable. A material that shows evidence of charring or sustaining combustion at a temperature less than 450° F is unacceptable for use in crew bay areas.

Odor, carbon monoxide, and organics, reference 9.- Materials shall be tested for carbon monoxide and total organics. If the material yields over 25 micrograms of carbon monoxide per gram of material or over 100 micrograms of total organics per gram, it will be rejected. If it passes this test, it will be evaluated for objectionable odor by a test panel of 5 to 10 members. If the odor is objectionable, the material will be unacceptable.

Friction and impact ignition, reference 9.- This test is to determine the sensitivity and compatibility of nonmetallic materials with pure oxygen for use in the high-pressure oxygen system. Only materials that have passed other required tests will be subject to this test. The material will be subjected to three successive tests at 1.5 kilogram meters impact testing at successively higher gaseous oxygen pressures until a reaction is observed by discoloration, evidence of combustion, or detonation. To be acceptable, the material must not show a reaction at the maximum use pressure plus 2000 psi.

Friction and impact ignition.- Materials shall not ignite when tested to the requirements of Appendix D of reference 10.

The presently applicable contractual specification (ref. 9) was published and placed on contract by CCA 2147 to record the criteria and requirements actually in force for the Apollo contract. Modifications to the basic document are made as the knowledge increases, and it was last revised in November 1969.

The contractor is primarily responsible for the selection of materials in contractor furnished equipment (CFE) as prescribed by contract. NASA publishes materials selection requirements and reviews materials selected by the contractor. A Material Selection Review Board is established at the contractor's facility to review material selection and to approve or reject all deviation requests. The contractor board submits all decisions to the Material Review Selection Board at MSC for review and approval. The prime board, MSC, indicates concurrence or nonconcurrency to the contractor board within 5 days of receipt of the lower board's decisions.

Present requirements for material selection are essentially the same as those previously cited and are listed in detail in reference 10.

Materials Listing

A listing of materials was prepared by Beech and furnished to NR. The listing was checked at NR for completeness and compatibility and entered into the Characteristics of Materials (COMAT) list and forwarded to MSC in October 1969. This COMAT package was transmitted to the MSC/GE Materials Engineering Support Unit where it was reviewed and signed off as complete and accurate by the Materials Engineering Unit Manager. All materials are shown to be compatible for the use contemplated except Drilube 822 which is an assembly lubricant used in very small quantities. The MSC COMAT shows this material classed as requiring the submission of a Material Usage Agreement (MUA) for approval.

The Drilube was judged acceptable for the use contemplated in accordance with the blanket waiver given for outgassing of materials tested at MSC on the 2TV-1 and CSM 101 vehicles.

This page left blank intentionally.

PART E9

SAFETY AND RELIABILITY AND QUALITY ASSURANCE (R&QA)

INTRODUCTION AND ORGANIZATION

General

The Apollo Program has a firmly established safety requirement in the basic program objective. The original objective of the program was to land men on the Moon and return them safely to the Earth. The program management, design, review, and monitoring procedures described in previous sections of this Appendix are designed to assure that all program problems, including safety, are presented to the appropriate management decision makers at selected program maturity points.

The safety system and organization is designed to provide an independent specialized monitoring and evaluation function for the program line management. The following figures and descriptions of responsibilities outline the safety organization of NASA as it applies to the Apollo Program, and the contractor-subcontractor organization as it applies to the Apollo Program generally, and the cryogenic gas storage system specifically.

NASA Headquarters

The Aerospace Safety Advisory Panel is established to provide a direct, nonorganizational overview on safety for all programs for the Administrator (fig. E9-1). The charter for this panel specifies access to any program information necessary for their safety audit function and full support of their requirements by the NASA Safety Officer and other elements of the organization.

The NASA Director of Safety is responsible for exercising functional management authority and responsibility over all NASA safety activities. This includes development of policy, procedures to implement policies, and review and evaluation of conformance to established policy. He is also charged with supporting Program Directors and Institutional Directors in discharging their safety responsibilities. His review and concurrence are required for the safety portion of each Project Plan and Project Approval Document.

The NASA Director of Safety reports to the Associate Administrator for Organization and Management.

The office of the Associate Administrator for Manned Space Flight (MSF) (fig. E4-3) has several offices with either a primary or secondary responsibility for safety.

The Director, Manned Space Flight Safety Office, has a dual organizational responsibility to the Associate Administrator for Manned Space Flight (AA/MSF) for program guidance and policy direction. He also serves in the office of the NASA Safety Director as Assistant Safety Director for Manned Space Flight Programs, assisting in the development of overall NASA-wide safety policy, guidance, and professional safety standards. In this NASA Assistant Safety Director assignment, he is under the cognizance of the Office of Organization and Management. In accomplishing his responsibility as Manned Space Flight Safety Director, he advises the MSF Program Directors and the AA/MSF on all matters involving manned flight safety and develops and documents appropriate safety policy for these programs. He audits the program offices and MSF Field Centers to insure compliance with established policy and develops accident investigation and reporting plans for use in the event of flight anomalies. He also develops the Manned Space Flight Awareness Program.

Bellcom, Inc., is under contract to AA/MSF to perform studies, technical fact finding and evaluation, analytical investigations, and related professional activities in support of Manned Space Flight Programs. In support of the Apollo Program, this contract capability is available under the direction of the Director, Apollo Program, for safety studies or analyses as required in support of his responsibilities to systematically identify hazards and risks and take all practical measures to reduce risks to acceptable levels.

Manned Space Flight Mission Directors are assigned as Deputy Program Directors for specific missions and are responsible for insuring thorough inter-Center/OMSF coordination for that mission. The Mission Director insures that consideration is given to all problems and proposed changes affecting safety and to advise the Program Director of any disagreement with proposed actions from the standpoint of assuring quality hardware and flight safety.

The Director, Mission Operations, is responsible for directing and evaluating the development of the total operational capability necessary for the conduct and support of Manned Space Flight missions. These responsibilities are performed in support of the Manned Space Flight Program Directors under the cognizance of the Associate Administrator for Manned Space Flight. In accomplishing this operational responsibility, the Mission Operations Director works with the MSF Director of Flight Safety to insure development of operation safety plans.

The Director of Reliability and Quality Assurance is responsible to the Assistant Administrator for Industry Affairs to formulate and develop reliability and quality assurance policies and to prescribe guidance and procedures to implement approved policies. He is also responsible for assessing the effectiveness of these programs throughout the Agency and for keeping the management informed of the status of the program. He participates in investigations of major accidents and mission failures whenever reliability and quality assurance could have been a contributing factor. He also initiates and conducts special studies of problems affecting the reliability and quality of NASA hardware.

The Director, Manned Spacecraft Center, under the supervision of the AA/MSF, manages the development activities of the Apollo Program, with emphasis on providing spacecraft, trained crews, and space flight techniques. In carrying out these functions, he procures spacecraft systems and monitors and directs contractor activities. He also selects and trains flightcrews, establishes mission and test requirements, and plans and executes missions under the direction of the Mission Operations Director.

The Director, John F. Kennedy Space Center (KSC), under the supervision of the AA/MSF, develops, operates, and manages the Merritt Island Launch Area (MLA) and assigned programs at the Eastern Test Range (ETR) and insures that KSC operations meet the requirements of NASA Safety Standards.

Manned Spacecraft Center

The Safety Office is the focal point for the development, implementation, and maintenance of a safety program at MSC. The office implements requirements established by NASA Headquarters, maintains a current MSC Safety Plan and Manual, and participates as an advisor to the Director, MSC, in major spacecraft reviews. The office assesses the effectiveness of contractors in their safety functions and assists MSC directorates, program offices, and contractors in safety matters.

The Safety Office is functionally divided into a number of subdivisions to accomplish their assigned duties, as shown in figure E9-2.

The Manned Flight Awareness Office is responsible for developing a motivational program to instill in each individual associated with manned space flight a personal awareness of their responsibility for the lives of the astronauts and mission success of space flight missions. This responsibility is largely accomplished by development and publication of motivational literature and by scheduling and coordinating astronaut and management official visits to contractor and subcontractor plants in support of the Manned Flight Awareness Program.

NASA MANNED SPACECRAFT CENTER

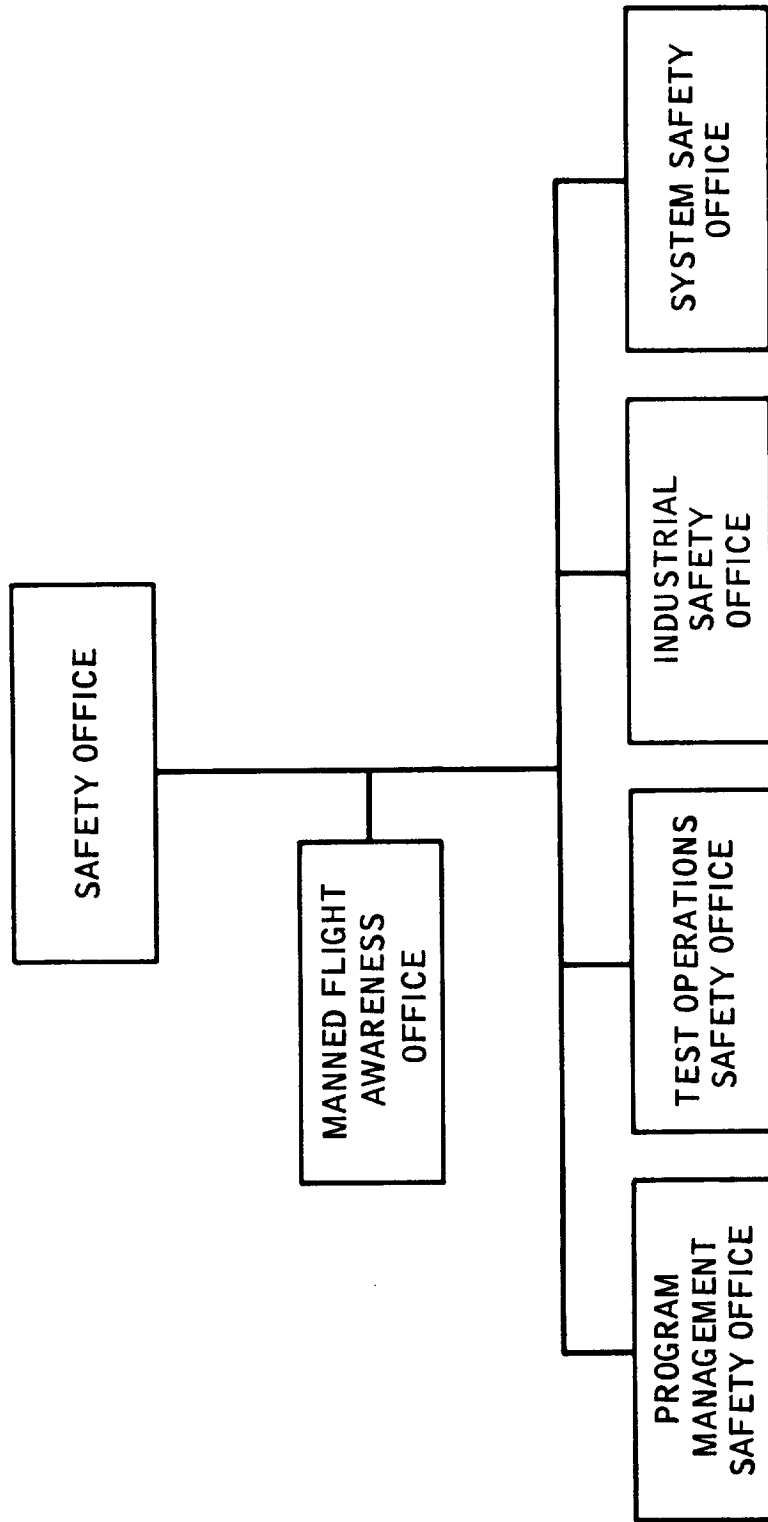

Figure E9-2.- MSC Safety Office organization.

The Program Management Safety Office develops and applies a system safety program for flight hardware contracts. System safety guidelines are identified to MSC program offices and directorates and through them to contractors. The Program Management Safety Office represents the Manager, Safety Office, on program major milestone reviews and evaluates contractor and MSC system safety requirements for particular programs. This office also provides for identification and tracking of hazards throughout the life of a system. In accomplishing this responsibility, the office assesses mission rules, flight plans, and crew procedures to identify potential hazards and assure that they are eliminated or controlled. They also evaluate design and procedure changes for safety implications and monitor space flight missions in real time to appraise the Manager, Safety Office, of safety-related anomalies. They maintain close interface with MSC program elements to provide inputs for trade-offs involving safety and performance.

The Test Operations Safety Office is the subdivision of the Safety Office that establishes a safety program to insure the safe conduct of hazardous tests involving human subjects, tests of GFE astronaut equipment, and special tests of spacecraft. The office evaluates test facilities and operations to determine hazardous activities and provides test officers for activities considered to be of an extremely hazardous nature. They compile and evaluate reports and findings of Operational Readiness Inspections (ORI's) and distribute these reports as required.

The System Safety Office develops, implements, and maintains a system safety program for manned spacecraft efforts involving preliminary analysis, definition, and design phases. The office also provides system safety support for other elements of the Safety Office. Specifically, this office assists in the preparation of system safety plans from the initial purchase order or request for proposal through the procurement stage and then audits the system safety activities of the contractor or MSC organizational element throughout the program.

The Industrial Safety Office directs and coordinates comprehensive industrial, public, and traffic safety programs, including a fire prevention and protection program and an ordnance safety program covering MSC operations and activities including test facilities; develops and coordinates the MSC/contractor industrial safety program; and evaluates the effectiveness of all MSC-directed industrial safety activities.

The Reliability and Quality Assurance Office at MSC (fig. E9-3) is a fundamental element in the safety system. The office is co-located with the Safety Office and the same man heads both offices. The R&QA office develops and implements the reliability and quality assurance programs for the Center to assure that spacecraft, spacecraft systems, and supporting systems are designed and built to perform satisfactorily in the environment for which they are designed. This office also reviews

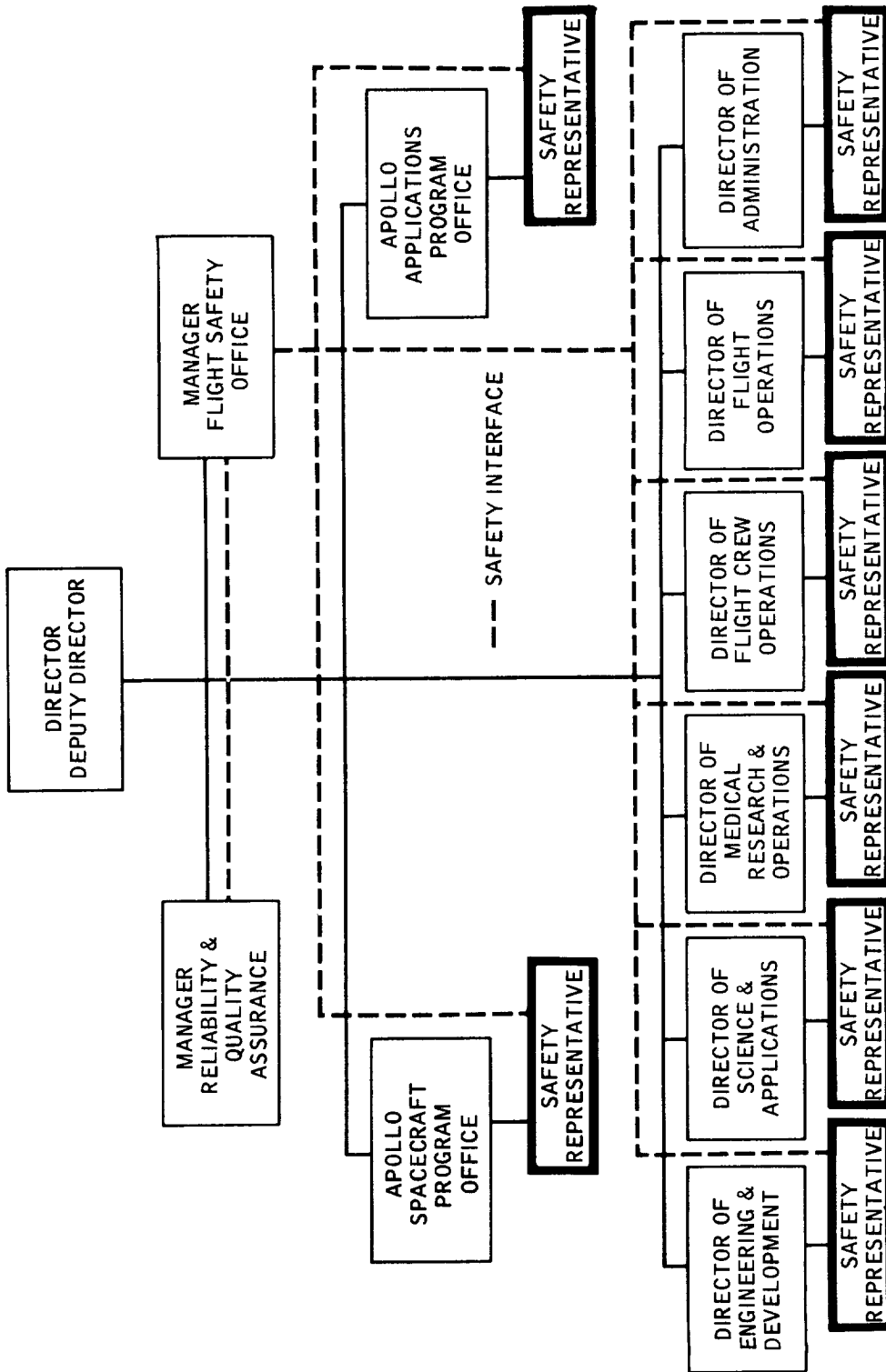

Figure E9-3.- Safety Functional Office, NASA Manned Spacecraft Center.

and evaluates R&QA information and activities of contractors and provides onsite monitoring. The office also provides specialized studies for safety reviews and provides direct support to program managers for design reviews, configuration management change control, flight readiness reviews, and real-time mission support.

The MSC Safety Plan establishes the organized MSC system safety program. The plan applies to Center activities and contractors under NASA/ MSC direction. The plan is oriented toward spacecraft systems and crew safety and does not cover all elements of a total safety program.

The general intention of the safety program is to establish the primary responsibility for safety of spacecraft and GSE hardware and software with the program office/contractor. The responsible directorates are recognized as having the primary responsibility for the safety of mission operation and crew procedures. The MSC Safety Office has the primary responsibility for assessing manned safety of spacecraft flight and ground testing and acting to insure system safety consideration by all MSC and program contractor elements.

The MSC offices and directorates with prime system safety responsibilities are shown in figure E9-3 with their functional relationships with the Safety Office indicated by the dashed lines. Each of these offices and directorates has established a single point of contact for all safety matters. This contact interfaces directly with the Safety Office and has unimpeded access to top management of his directorate or office on safety matters. The spacecraft hardware and operations safety responsibilities of each of these offices are as follows:

1. Program offices manage the design, test, and manufacture of spacecraft systems and related GSE to assure proper contractual safety requirements. They implement Safety Office policies and procedures and resolve incompatibilities between mission requirements, mission profiles, operational constraints, and spacecraft capabilities. They also provide the basis for certifying design maturity and manned flight safety.

2. Flight Operations Directorate is responsible for:

- (a) Trajectory and flight dynamics analysis.
- (b) Mission control requirements.
- (c) Mission rules and spacecraft systems handbooks.
- (d) Ground instrumentation requirements.
- (e) Emergency real-time procedures.

(f) Landing and recovery testing and operations. Coordinating recovery operations with DOD.

(g) Coordinating safety matters with Air Force Eastern Test Range.

(h) Providing the basis for certifying design maturity and manned flight safety.

3. Flight Crew Operations Directorate:

(a) Assures the adequacy of flightcrew selection and training.

(b) Establishes crew procedures and spacecraft operational constraints.

(c) Conducts mission planning.

(d) Establishes crew station design requirements.

(e) Conducts simulations (nominal operations and abort).

(f) Develops operations handbooks and general flight procedures.

(g) Approves all KSC test and checkout operating procedures involving flightcrews.

(h) Conducts and supports tests with aircraft where they are used to develop and evaluate operational capabilities of space-related hardware and operations.

(i) Provides the basis for certifying design maturity and manned flight safety.

4. The Engineering and Development Directorate:

(a) Assures the adequacy of design, manufacture, and test of equipment and the cognizance of this Directorate.

(b) Assures that safety is properly integrated and that system safety requirements are provided in contractual requirements.

(c) Provides technical support to MSC programs through sub-system management programs.

5. The Science and Applications Directorate:

- (a) Performs flight experiments and special experimental tasks.
- (b) Assures proper integration of system safety policies and requirements into design and operation of all space science experiments.
- (c) Coordinates with Safety Office on safety requirements for special experiments.
- (d) Assures that safety requirements are properly implemented in the design and operation of the Lunar Receiving Laboratory.
- (e) Provides the basis for certifying design maturity and manned flight safety.

6. The Reliability and Quality Assurance Office:

- (a) Supplies failure mode and effect analysis of spacecraft systems, subsystems, GFE, and experiments.
- (b) Provides failure trends.
- (c) Determines safety categories.
- (d) Coordinates with Government inspection agencies to insure that safety-critical items satisfy established requirements.
- (e) Approves failure closeout statements.

7. The Medical Research and Operations Directorate:

- (a) Provides world-wide medical support for manned missions and provides flight surgeons during missions.
- (b) Provides medical coverage for all tests involving human subjects.
- (c) Monitors the physical condition of human participants with the authority to stop testing if continuation might result in injury or death to the test subject.
- (d) Ascertain by physical examinations the satisfactory physical condition of the test personnel or flightcrews and certify their satisfactory physiological condition.
- (e) Participates in test planning and approves all physiological test standard procedures involving human participants.

(f) Establishes the physiological limits to which man can be subjected.

(g) Reviews plans and changes for construction of test facilities involving humans.

(h) Has responsibility for biological safety during Lunar Receiving Laboratory operations.

The Safety Office also maintains a safety interface between NASA Headquarters, MSC, other centers, and other Government agencies as shown in figure E9-4. The areas of safety coordination with these organizations are described as follows. In the event problems arise at these interfaces, interagency panels will be convened for problem resolution.

MSC/KSC interface in eight areas that are safety oriented or related:

1. Test operations at KSC.
2. Flight hardware management.
3. Flightcrew activities at KSC.
4. Configuration control.
5. Quality control and inspection at KSC.
6. Safety at KSC.
7. Experiment management.
8. Launch and flight operations.

Any problems which arise are resolved through the formally organized intercenter panels.

MSC/DOD Safety Regulations are primarily at the Air Force Eastern Test Range Facility. DOD provides the following functions:

1. Safety-related base support as required:
 - (a) Fire protection and control
 - (b) Explosive ordnance disposal

NASA MANNED SPACECRAFT CENTER

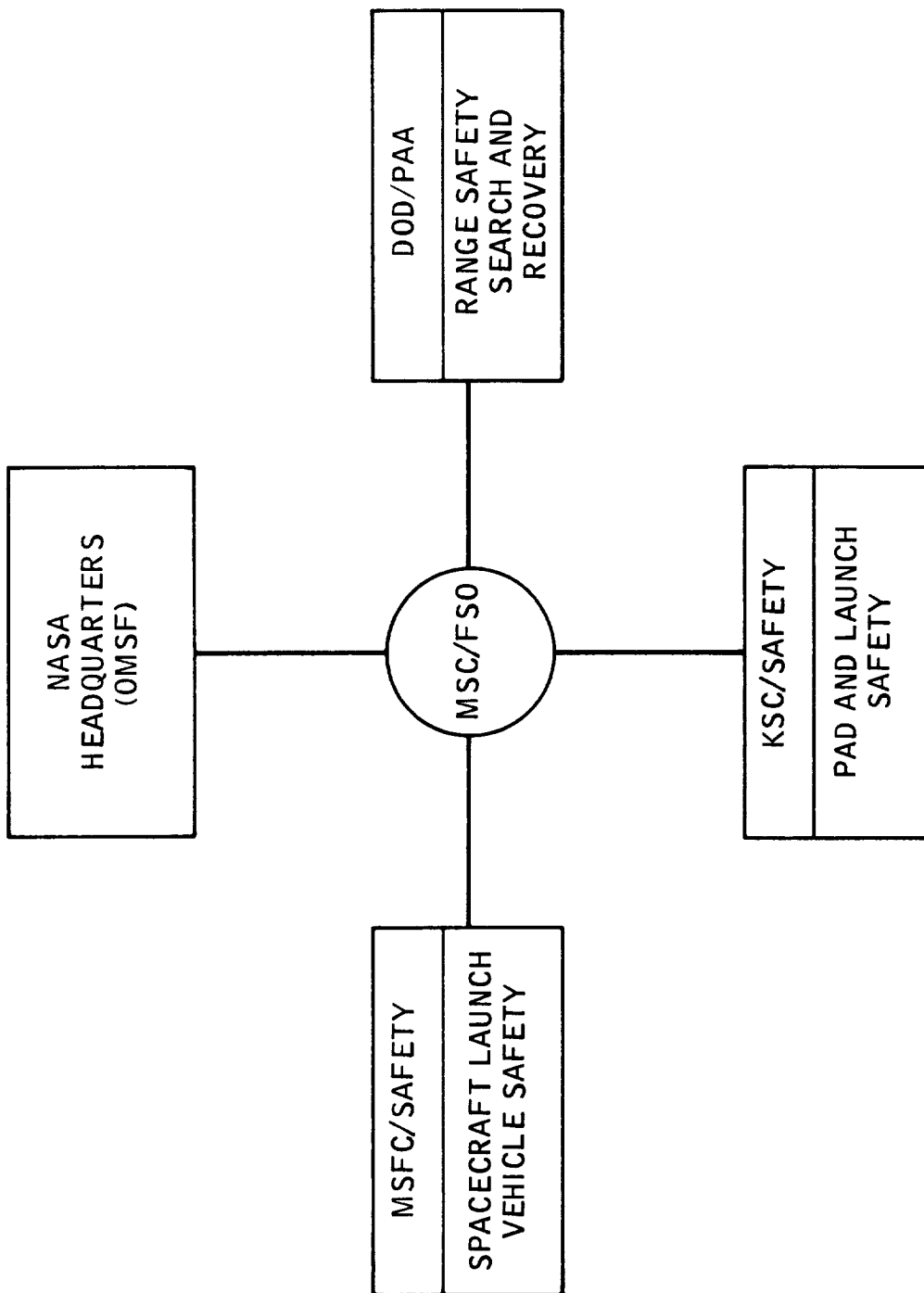

Figure E9-4.- MSC interrelationship with other organizations safety offices.

- (c) Bioenvironmental engineering
 - (d) Security
2. Missile ground safety as required.
 3. Range safety.
 4. Search and sea recovery.

John F. Kennedy Space Center

The Kennedy Space Center takes the test and checkout requirements and test and checkout specifications and criteria documents prepared by the development centers and develops plans and procedures for the handling and launch of spacecraft. To accomplish this responsibility, KSC prepares and coordinates Test and Checkout Plans and implementing Test and Checkout Procedures.

The KSC Safety Office.- This office plans and manages an integrated hazard-assessment and risk-reduction program for all activities at KSC and for all NASA activities at both Cape Kennedy Air Force Station (CKAFS), Florida, and Vandenburg Air Force Base (VAFB), California. This program includes:

1. Handling, storing, and transporting hazardous items such as missile propellants, ordnance, high-pressure gases, toxic fluids, and radioactive devices.
2. Insuring safety requirements are included in all contracts initiated or administered by KSC and that contractor performance is periodically evaluated.
3. Performing engineering system safety studies to assure inclusion of safety requirements in engineering design of space vehicle test and checkout (launch complex and ground support equipment/facilities and operations).
4. Insuring that safety controls and required support are in effect during performance of all operations.
5. Approving siting, construction, and modification plans for safety aspects.

The office conducts safety surveillance while selected operations are actually in progress, with authority to halt activities under specified circumstances.

Prior to publication of a test and checkout procedure (TCP) for (a) operational checkout of flight hardware, (b) functional verification and operational control of GSE, and (c) operational instructions to service, handle, and transport end-item flight hardware during prelaunch and launch operations, the KSC Safety Office reviews and approves these procedures to assure that operations are compatible with KSC safety criteria and use appropriate safety personnel, techniques, and equipment.

Prior to publication of a technical procedure involving hazardous operations to (a) authorize work, (b) provide engineering instructions, and (c) establish methods of work control, the KSC Safety Office reviews and approves the procedure to assure that operations are compatible with KSC safety criteria and use appropriate safety personnel, techniques, and equipment.

During selected operations that involve hazardous sequences, the Safety Office has representatives on site. In the case of major integrated tests, i.e., CDDT, the number of representatives can be as high as 12, with three people on station in the Launch Control Center firing room and the remainder at various positions on the launch pad. The safety representative insures that safety requirements are implemented, approves or disapproves on-the-spot changes to Category I procedures made either by Procedure Change Request (PCR) or Deviation Sheets and assists the test supervisor in obtaining resolution on matters that have safety overtones.

North American Rockwell Corporation - Space Division

The NR System Safety Plan for the Apollo CSM program is the implementing document for the program required by MSC specification under the basic CSM contract.

The objective of the system is the elimination or control of risks to personnel and equipment throughout the manufacture, checkout, and flight missions of the Apollo CSM. To achieve this objective the CSM system safety program has an organization as shown in figure E9-5. The CSM System Safety Office reports directly to the CSM General Manager and is headed by the Assistant to the General Manager for CSM System Safety. The Assistant to the General Manager for CSM System Safety acts for the General Manager in the conduct of activities relating to all facets of safety for the CSM programs, and is a permanent member of the Space Division Safety Committee. He directs and monitors program activities necessary to assure an effective system safety program. He is responsible for preparation and compatibility of the CSM system safety programs at all sites with the exception of Launch Operations at KSC.

NORTH AMERICAN ROCKWELL CORPORATION

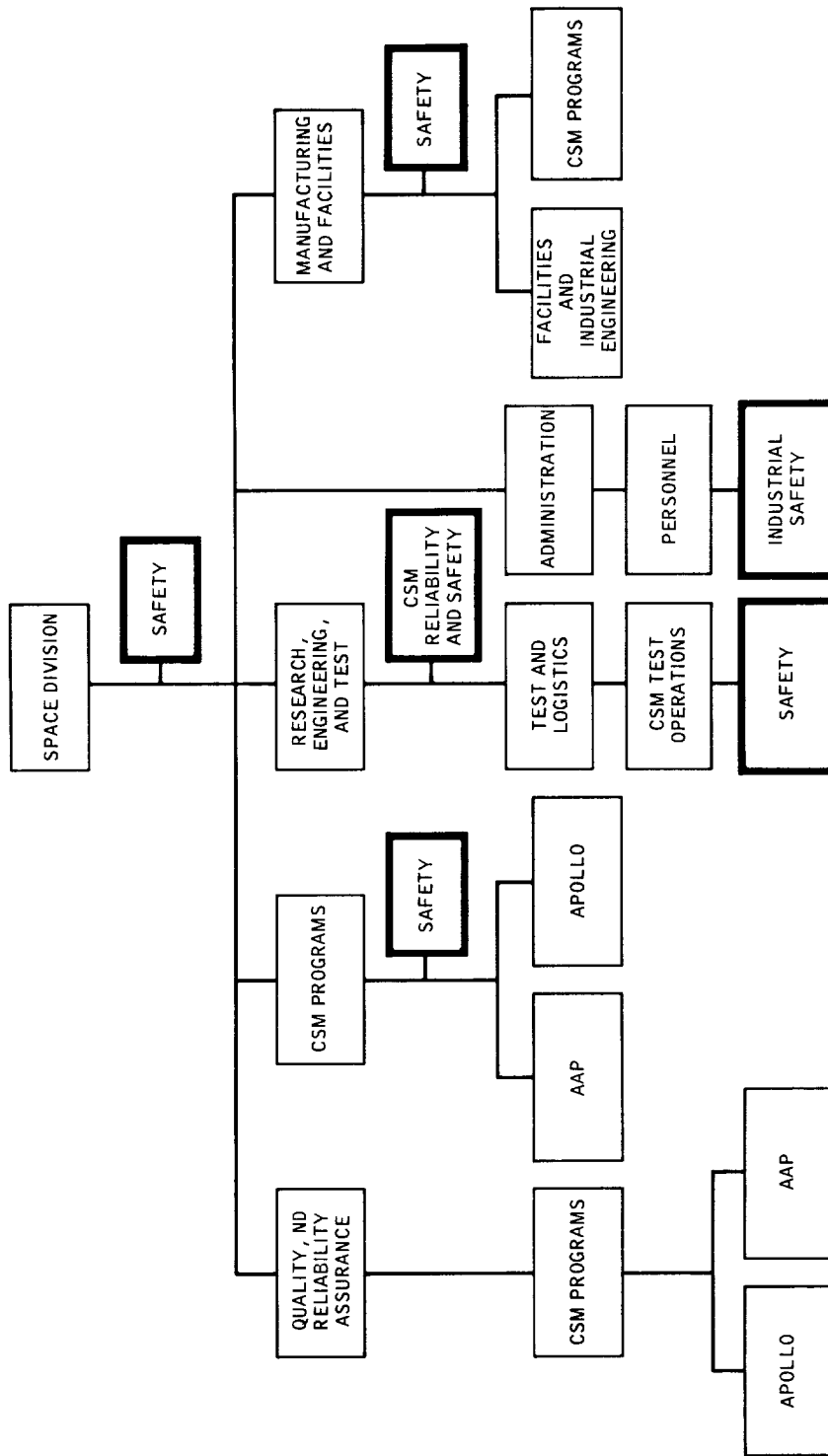

Figure E9-5.- Apollo CSM System Safety Program organization.

Specific responsibilities of the NR CSM Safety Office include:

1. Develop and direct the system safety program for the CSM programs.
2. Participate in Customer Acceptance Readiness Reviews (CARR's) and Flight Readiness Reviews (FRR's) and assess problems submitted for flightcrew safety impact.
3. Supervise the three CSM functional departments relative to system safety and interface with other agencies and divisions of NR concerning CSM safety.
4. Participate as a member of the NR Change Control Board (CCB) to review proposed changes and assure changes do not jeopardize ground and flightcrew safety.
5. Maintain status report system on all safety problems and design changes affecting safety.

The Engineering Division System Safety Office:

1. Reviews and evaluates safety effect of all Engineering Design Change (EDC) packages.
2. Reviews and assesses engineering analyses such as FMEA's, SPF's, and similar documents for identified hazards which jeopardize crew safety. Evaluate their corrective action and disposition.
3. Participates in postflight evaluations when requested by MSC for evaluation of crew safety problems.

The Manufacturing Division System Safety Office:

1. Provides safety checklists to aid manufacturing personnel in preparing documents and conducting safety surveys.
2. Assures that CSM manufacturing test, handling, and transport procedures and work documents contain appropriate system safety provisions.
3. Assures that operations defined as safety-critical are adequately planned and monitored.

The Test Operations System Safety Office is responsible for protection of the operational integrity of the CSM during checkout at Downey and testing at field sites. This office:

1. Generates system safety checklists for preparing Test Operations and conducting safety surveys.
2. Reviews all test, checkout, and operations procedures for adequate system safety requirements.
3. Reviews all safety-critical operations to assure adequacy of test set-up, documentation, and personnel qualification. Assures that adequate emergency plans and procedures are established and in use for these safety-critical operations.
4. Coordinates crew safety provisions and requirements and, when appropriate, recommends corrective action for identified hazards associated with crew procedures.

The Safety Plan appears to be operating satisfactorily according to the most recent MSC audit. The multiple safety offices and fragmented responsibilities warrant a critical review aimed at evaluating the expected effectiveness of a more centrally managed program.

The Reliability and Quality Assurance function, as shown in figure E9-5, has a functional responsibility to the corporate quality office and a program management responsibility to the CSM Program Manager. They are responsible for monitoring the manufacturing orders for proper R&QA callouts, verification inspection callouts, planned inspection callouts, and proper implementation of R&QA requirements in the planning operation. They also compile the System Summary Acceptance Documents (SSAD's) for Customer Acceptance Readiness Reviews (CARR's) and Flight Readiness Reviews (FRR's). They conduct quality inspections on manufacturing processes and testing operations and participate in design reviews. They also verify material usage and make and dispose of failed hardware.

The reliability function monitors design specifications and prepares failure effects and criticality analyses. They develop and supervise maintainability analyses, perform failure reporting analyses and recommend corrective action, support end-item reviews, perform problem investigations, and support the problem items.

Beech Aircraft Corporation

The overall organization of the Beech Aircraft Corporation, Boulder Division, is shown in figure E4-11, and a functional breakdown of the

office of the Apollo Program is shown in figure E4-12. The Beech Quality Control Plan establishes the detailed methods and procedures for accomplishing the positive quality control required by NASA of its contractors and subcontractors in the Apollo Program. The Beech plan does comply with the NASA requirements of NPC-200-2, "Quality Program Provisions for Space Systems Contractors" (ref. 11), and is applicable to the material, parts, components, subassemblies, installations, and system and subsystems purchased, tested, and manufactured for the Apollo supercritical gas storage system.

The system operates to assure maintenance of the basic approved configuration baseline by reviewing and documenting materials, processes, vendor-provided equipment, testing procedures, and manufacturing operations.

The Beech Reliability Program Plan provides for management and operation of the reliability system. It provides for the monitoring and reporting of all tests, and maintenance of a complete record of action on discrepancies and failures; and participates in corrective action and research required for Failure Mode Effects Analysis (FMEA) analyses, logic diagrams, math models, and reliability predictions and apportionments. Documentation of these efforts are furnished to the NR and NASA to fulfill contract requirements. The Beech Aircraft reliability and quality assurance organization and operation appear to be adequate and in compliance with contract and NPC-200-2 requirements. Manufacturing procedures and process control were surveyed and found in good condition and documentation such as the FMEA's was examined and found to be satisfactory.

SAFETY AND R&QA AUDITS

Regular audits of the Safety and R&QA functional areas are made of the field centers by NASA Headquarters teams. The Centers, in turn, make similar audits of their prime contractors. These contractors conduct audits and survey visits with their subcontractors and suppliers. In addition, the NASA Aerospace Safety Advisory Panel has reviewed certain aspects of the manned space flight safety program. These reports are included in the Apollo 13 Review Board files.

Consideration of these audits and reviews by the Management Panel showed no significant items relative to the Apollo 13 accident. The general functioning of the overall Safety and R&QA programs was found to be consistent with good practices.

MSC SAFETY/R&QA PARTICIPATION

The MSC Safety Office is responsible for implementing safety policies and assuring safety in design, development, and operation of spacecraft. The R&QA function is responsible for assuring that spacecraft and supporting systems are designed and built to perform in the environment for which they are built. The two functions, Safety/R&QA, are mutually dependent, have many common information and data requirements, and have many review and monitoring functions that support them both.

Safety/R&QA are closely involved in the entire design, development, test, and flight phase of all spacecraft components, systems, and subsystems. This includes participation in formal reviews such as the Preliminary Design Reviews (PDR), Critical Design Reviews (CDR), First Article Configuration Inspection (FACI), and Customer Acceptance Readiness Reviews (CARR) conducted by the Program Office. Safety/R&QA also participates in Design Certification Reviews (DCR) and Flight Readiness Reviews (FRR).

These offices implement general policy and establish specific programs for contractors. They then monitor these programs throughout the contract period to assure safety and quality of performance by the contractor.

This review considered some of the activities of these two offices from the CARR through the post-touchdown phase of the command and service module of Apollo 13.

CARR's are held in two phases at present: Phase I prior to the initiation of subsystem testing and Phase III prior to shipping the assembled vehicle. MSC R&QA reviewed documentation for Phase III CARR for CSM 109 with the following specific results.

Phase III CARR for CSM 109

1. No hardware will exceed its allowable operational storage limits during KSC operation and flight.
2. No known parts problems exist that will constrain shipment of CSM 109.
3. There are 854 Certification Test Requirements (CTR's) for equipment applicable to CSM 109. Testing is incomplete for six and certification will not be complete at time of delivery. This status is significantly better than previous CSM's, however, and shows an improving trend.

4. An improving trend in spacecraft quality was shown by a review of NR-Downey discrepancy reports on CSM 109.

5. Verification of nonmetallic materials has been accomplished and establishes that all exposed nonmetallic materials have been identified and approved or deviations written and accepted.

6. All known single-point failures applicable to CSM 109 have been reviewed and are acceptable.

A comparison of data shown in the R&QA review for CSM 109 and previous CSM spacecraft shows that CSM 109 has shown substantial improvement in most R&QA and safety categories and no decrement in safety in any area.

FRR R&QA Summary

The next formal review was the Apollo 13 Flight Readiness Review (FRR).

1. All limited-life items adequate to support flight.
2. No known electrical, electronic, or electromechanical problems exist that would constrain launch.
3. No Certification Test Requirements constrain flight, since all have been approved except one which will be certified by analysis prior to flight.
4. All known single-point failures have been reviewed and are considered acceptable.
5. The overall quality of CSM 109 shows a favorable trend relative to previous spacecraft.

The Flight Safety assessment at the FRR was:

6. The system safety assessment of planned mission flight activities and spacecraft functions disclosed no safety concerns that would constrain the Apollo 13 flight scheduled for launch on April 11, 1970.
7. Four changes from previous missions have been made which reduced flight risks.
8. The risks unique to Apollo 13 involve: (a) programming S-IVB stage for lunar impact during translunar coast; (b) performing lunar descent orbit insertion with CSM/LM docked; (c) operating power drill on

lunar surface; and (d) performing PLSS communication degradation test during lunar surface EVA. These risks are not of constraining magnitude.

Weekly Safety/R&QA Report

In addition to the formal CARR, FRR, and other reviews, information is furnished to the Apollo Program Office and the Director, MSC, on a weekly basis of the activity of Safety and R&QA relative to particular spacecraft through the Weekly Activity Reports. Abbreviated mention of some items from this Weekly Report from January 1970 to April 10, 1970, concerning the Apollo 13 and CSM 109 follows.

January 8-15, 1970.- Thirteen open certification items for Apollo 13 were reported. Pacing items are four lunar camera items scheduled to be closed in February.

January 15-22, 1970.- CSM 109 FRR data review generated 10 R&QA Review Item Dispositions (RID's). CSM 109 FRR subsystem working session was conducted at KSC on January 15-16. FRR RID's were generated and submitted for preboard action on January 25. Readiness statements were prepared for CSM 109.

January 22-28, 1970.- An assessment of CSM 104 through 109 failures at KSC was conducted. Detailed assessment will be made to determine reasons failures were not discovered at NR before shipment.

Safety Office briefed Astronaut Conrad on proposed procedure change for Mode 4 abort. Conrad will review with other astronauts, including Apollo 13 Commander.

January 30-February 4, 1970.- Ground support equipment (GSE) at KSC supporting CSM 109 is defective and may provide a countdown demonstration and countdown constraint unless the situation is remedied. NR is studying the problem. The Apollo 13 Safety Assessment Study of Mission Phases from translunar injection through CSM descent orbit injection has been completed and will be distributed by February 4, 1970. The biweekly meeting of MSC Safety/Boeing System Safety on Apollo mission concerns was held January 30. Seventeen Apollo 13 safety concerns were reviewed. Eight of the seventeen were closed.

February 12-18, 1970.- R&QA and Apollo Test Division met to discuss anomaly reporting effort. The discussion disclosed no duplication of effort and agreement was reached that the Apollo Mission Anomaly Test would be the guide for anomaly investigations. As of this date, only one GSE problem is open. It is expected to be resolved by the CDDT.

February 19-26, 1970.- The Safety Offices Assessment Report for Apollo 13 has been prepared. There are no constraining items in the report.

February 26-March 5, 1970.- The Apollo 13 R&QA Flight Readiness Assessment Report was completed February 26, 1970. R&QA agrees with the data and conclusions drawn. Of the five items listed as requiring verification, only one (referring to LM-7 rate gyro) is still active and should be resolved March 6. The Safety Office Assessment Report was presented at MSC's FRR on February 26, 1970. No constraining items exist. Two items are to be presented involving crew procedures.

March 20-26, 1970.- An R&QA review will be held during the afternoon and evening before the Apollo 13 launch to reaffirm launch, and results will be discussed with the CSM Manager. The mission plan and information notebook for the Apollo 13 mission is being prepared for Safety and R&QA mission support. The Safety Office provided the Deputy Manager with a written assessment of an R&QA single-point OPS/PLSS leakage failure. The Crew Systems Division is aware of the problem and is developing a work-around procedure.

April 3-9, 1970.- Open problems with potential Apollo 13 effectivity continue to be worked. Last planned status report to ASPO is scheduled for April 10, 1970. It is anticipated that all open problems will be closed or explained by that time.

April 10-16, 1970.- Final Apollo 13 Single Failure Point Summary was made during this time and approved by subsystem manager. All reported problems effective against Apollo 13 were closed or explained prior to launch. Also, all ALERTS for Apollo 13 were closed prior to launch. R&QA and Safety activities have been mainly to support changes in the mission brought about by loss of the oxygen supply.

Apollo 13 Mission Real-Time Activities

The Safety/R&QA functions support the premission and mission activities of Apollo flights in real time. The purpose of this support is twofold. First, the Safety/R&QA personnel, both in-house and contract, provide a contact for the mission group to call on for specialized support at any time during the mission from launch minus 9 days through splashdown. There are also specialized R&QA/Safety personnel available at the contractor's plants, NR and Grumman, for consultation as required. Secondly, the Safety/R&QA people are monitoring mission activities to make independent safety assessments and evaluations for future crew safety and mission readiness purposes. For this purpose, the monitoring team maintains a log of problems and occurrences that is used to prepare a

support anomaly list that is later resolved with the Project Test Division in the preparation of the Mission Anomaly list. The Safety/R&QA support operation for the Apollo 13 mission included the following activities:

Prelaunch. -

Daily problem closeout meeting: Meetings were held daily to review the status of hardware problems, certification tests, limited-life items, and other pertinent reliability concerns to assure that all potential problems had been properly evaluated and resolved. Headquarters R&QA was also represented at these meetings.

R&QA/Safety status meeting: A meeting of R&QA and Safety personnel was held on Friday evening, April 10, 1970, to review the status of all known and potential problems on Apollo 13. The meeting was chaired by the Manager, Safety and R&QA Offices. Following the meeting, the CSM Project Manager was informed of the results of the meeting. Headquarters R&QA was represented at the meeting.

Daily launch readiness problem report: This was initiated February 9, 1970, and the final report was issued on the morning of April 11, 1970, indicating no open problems against Apollo 13 hardware.

Daily bulletins: Apollo 13 bulletins were issued daily by the Control Center to keep personnel informed as to the status of Apollo 13 as it neared launch.

Countdown monitoring: Monitoring activities at MSC were initiated at T - 2 days and continued through the mission. Headquarters personnel maintained 24-hour monitoring of countdown activities at KSC up until launch.

Quality data review: MSC quality personnel at KSC reviewed IDR's DR's, etc., at KSC as the problems occurred to assure immediate evaluation of these problems.

Problem review and evaluation: Safety/R&QA participated in review and evaluation of hardware problems to determine potential mission impact. These included the lunar module cryogenic helium tank pressure rise problem and the oxygen tank umbilical quick-disconnect leakage occurrence.

Launch to accident. -

Monitoring activities: Real-time monitoring of Apollo 13 was maintained at MSC and in the GE Mission Evaluation Room offsite. A

control center was also manned by contractor personnel on a 24-hour basis to provide a central focal point for all Safety/R&QA missions activities.

Daily bulletins: Bulletins reporting the mission status were issued daily.

Flight anomalies: As suspect flight anomalies occurred, they were posted in the Control Center. R&QA personnel were requested to review and evaluate these occurrences as soon as feasible after the events were reported.

Requests for support: Requests for R&QA support for Test Division or other NASA groups were received and were worked as required. Three such requests were received prior to the accident. These requests were for failure histories, failure mode evaluations, etc., on the cryogenic helium tank pressure rise problem, the ECS suit pressure transducer, and on the oxygen tank no. 2 quantity gaging probe problem.

Postaccident.-

Safety/R&QA activities immediately following the Apollo 13 accident concentrated on compilation of subsystem data to determine the factors involved in the safe return of the crew--including single failure points. It included:

Safe-return factors: Each spacecraft subsystem was reviewed to identify those areas and concerns affecting the safe return of the crew in the emergency Apollo 13 configuration. A "Safe Return Factors" book was compiled and made available for reference in the Planning Room (GE).

Quality data: The quality control data on the CSM 109 oxygen tank no. 2 was compiled and a search of these records for any questionable items was initiated.

Historical data: The historical data, including failures, on similar oxygen tanks were searched for evidence of significant problem areas, as was the test and checkout history of the CSM 109 cryogenic and EPS systems.

Flight data review Safety/R&QA: Personnel participated in the review of flight data as a part of a team.

Configuration review: A review of the equipment and its relative location in bay 4 of the SM was made.

Single failure points: A study was prepared listing all Criticality I SFP's in both the CSM and the LM based upon the emergency configuration of Apollo 13.

Unexplained anomalies: A review was made of each of the explained anomalies approved for Apollo 13 to determine any potential connection with the Apollo 13 accident.

Daily review meeting: An R&QA/Safety Review meeting was held daily at 4 p.m. c.s.t. on April 14-17, 1970, to review the status and progress of the activities listed in the preceding paragraphs. The Manager, Safety and R&QA, strongly emphasized during these meetings the need to concentrate on those activities affecting the safe return of the astronauts. The activities designed to determine the cause of the accident were pursued only when they did not interfere with this primary concern.

CONCLUSION

The MSC Safety/R&QA plans and procedures appear to be adequate and complete for their assigned responsibilities. Their maintenance of equipment and system records, identification of suspect and failure areas, and followup corrective actions through the Government and contractor organization are adequate. Monitoring of contractors is presently accomplished with onsite personnel and visits rather than by formal audits. This appears adequate at present but should be supplemented by formal audit visits whenever possible.

The preflight System Safety Assessments made for each flight of the Apollo Program are thorough and timely and the flight monitoring support of Safety/R&QA is good. The postflight anomaly identification and tracking system is good.

The Safety/R&QA area appears to be generally adequate with proper procedures, good organization, and well-motivated personnel.

This page left blank intentionally.

PART E10

SECURITY

Security surveys were conducted at Beech Aircraft Corporation, Boulder Division, and North American Rockwell Corporation, Downey, California, during the time period of April 27, 1970, through May 5, 1970.

The purpose of these investigations was to evaluate the adequacy of the security programs at each location during the time periods that the Apollo oxygen tanks were in custody at the respective industrial plants. An extension of the accident investigation involved reconstructing the security systems and procedures applicable to the oxygen tanks from the time of shipment from NR to KSC and through launch of Apollo 13 on April 11, 1970. To fulfill the stated purpose of this inquiry involved evaluation of security programs at Beech, NR, and KSC from April 1, 1966, through April 11, 1970.

The security programs at each contractor location were found to be satisfactory and adequate to provide for the physical protection of the oxygen tanks. The security procedures provided at KSC were found excellent and assured the integrity of all Apollo 13 hardware from initial receipt on June 26, 1969, through launch on April 11, 1970.

Federal and local agencies acquainted with the security programs at NR and Beech were contacted and gave favorable evaluations of each contractor's performance during the pertinent time period.

Industrial security files were reviewed for incidents involving the oxygen tanks at Beech and spacecraft 106 and 109 at NR. The results at Beech were negative, and the incidents located at NR have been reported for technical evaluation in the preliminary report submitted May 8, 1970, to the Review Board Chairman and Manager, Apollo Spacecraft Program Office.

The determination reached as the result of this survey is that no evidence was discovered that the failure of the Apollo 13 oxygen tanks was the result of any willful, deliberate, or malicious act on the part of an individual at the contractor facilities surveyed or at KSC. Physical security measures were sufficiently designed, implemented, and monitored so as to preclude unauthorized access to the hardware associated with this investigation.

REFERENCES

1. Anon.: MSC/Apollo Program Management. MSCM 8020, Manned Spacecraft Center, Nov. 27, 1967.
2. Anon.: Apollo Spacecraft Program Configuration Management Manual. SB07-C-001, Manned Spacecraft Center, Dec. 15, 1967.
3. Anon.: Apollo Configuration Management Manual. NPC 500-1, MSC Supplement No. 1, Revision B, April 26, 1965.
4. Anon.: Engineering Changes to Weapons, Systems, Equipment, and Facilities. Air Force-Navy Aeronautical Bulletin No. 445, July 12, 1963.
5. Anon.: Test and Checkout Requirements Document for KSC CSM 108 and Subsequent Vehicles. Manned Spacecraft Center, July 28, 1969.
6. Anon.: Storage Subsystem--Cryogenic. Specification No. MC 901-0005, North American Aviation, Inc., March 16, 1966.
7. Anon.: End-Item Acceptance Data Package Book. CM-A-0499B, Beech Aircraft Corp.
8. Anon.: Apollo 13 CGSS Oxygen Tank Fluid Detank Analysis. Beech Memorandum Report 15230, Beech Aircraft Corp., April 2, 1970.
9. Anon.: Apollo Spacecraft Nonmetallic Materials Requirements. MSC-PA-D-67-13, Addendum No. 1, Manned Spacecraft Center, Nov. 7, 1969.
10. Anon.: Procedures and Requirements for the Evaluation of Spacecraft Nonmetallic Materials. MSC-A-D-66-3, Revision A, Manned Spacecraft Center, June 5, 1967.
11. Anon.: Quality Program Provision for Space Systems Contractors. NPC 200-2, NASA Headquarters, April 1962.