

Errata  
sheets



# **REPORT OF APOLLO 204 REVIEW BOARD**

**TO**

**THE ADMINISTRATOR**

**NATIONAL AERONAUTICS AND SPACE ADMINISTRATION**

## **APPENDIX G**

**PART 2**

169 pp.

### **APOLLO SPACECRAFT**

The spacecraft (S/C) consists of a launch escape system (LES) assembly, command module (C/M), service module (S/M), and the spacecraft/lunar module adapter (SLA). The LES assembly provides the means for rapidly separating the C/M from the S/M during pad or suborbital aborts. The C/M forms the spacecraft control center, contains necessary automatic and manual equipment to control and monitor the spacecraft systems, and contains the required equipment for safety and comfort of the crew. The S/M is a cylindrical structure located between the C/M and the SLA. It contains the propulsion systems for attitude and velocity change maneuvers. Most of the consumables used in the mission are stored in the S/M. The SLA is a truncated cone which connects the S/M to the launch vehicle. It also provides the space wherein the lunar module (L/M) is carried on lunar missions.

### **TEST IN PROGRESS AT TIME OF ACCIDENT**

Spacecraft 012 was undergoing a "Plugs Out Integrated Test" at the time of the accident on January 27, 1967. Operational Checkout Procedure, designated OCP FO-K-0021-1 applied to this test. Within this report this procedure is often referred to as OCP-0021.

### **TESTS AND ANALYSES**

Results of tests and analyses not complete at the time of publication of this report will be contained in Appendix G, Addenda and Corrigenda.

### **CONVERSION OF TIME**

Throughout this report, time is stated in Greenwich Mean Time (GMT). To convert GMT to Eastern Standard Time (EST), subtract 17 hours. For example, 23:31 GMT converted is 6:31 p.m. EST.

**Addenda and Corrigenda**

**Appendix G Part 2**

**Section 1**  
**Chronology of Board Activities**  
**April 1, 1967 to May 24, 1967**

**Section 2**  
**Congressional Correspondence**

**Section 3**  
**Final Report of Panel 18**

**Section 4**  
**Errata Sheets**

**Section 5**  
**Report of Test Results**

**Section 6**  
**Report to Deputy Administrator, NASA**

**Section 7**  
**Correspondence**



SECTION 1

CHRONOLOGY OF BOARD ACTIVITIES

(April 1 - May 24, 1967)



CHRONOLOGY OF APOLLO 204 REVIEW BOARD ACTIVITIES SUBSEQUENT TO  
THE LAST GENERAL SESSION OF MARCH 31, 1967

April 1 - 2, 1967

The Board Members and Counsel to the Board began the final draft of the Board's Report to the Administrator.

April 3 - 8, 1967

The Board Members and Counsel to the Board reviewed, and corrected as necessary, the final drafts of all the Panel Reports to be included in the Board's Report. The Report to the Administrator was completed noon, April 8, 1967.

April 5, 1967

The Hon. George P. Miller, Chairman, Committee on Science and Astronautics, House of Representatives, met briefly with the Chairman of the Apollo 204 Review Board and was introduced to the Members of the Board and Counsel. Colonel Frank Borman was asked by the Chairman to escort Mr. Miller in the Display Area in the Pyrotechnics Installation Building, KSC.

April 8, 1967

At 3 p.m. Board Members (less Colonel Borman) and Board Counsel departed KSC for LRC.

April 9, 1967

The Board Members (less Colonel Borman and White) and Board Counsel departed LRC for NASA Headquarters. At 4 p.m. the entire Board and Counsel met with the Administrator, the Deputy Administrator, the Associate Administrator for Manned Space Flight, the Apollo Program Office and the Functional Managers of NASA Headquarters. The Board explained its findings, determinations and recommendations to the Administrator and to other members of NASA Headquarters.

Also on this date delivery of the Report was made to the Administrator, less Appendices D 1-4, D 6-10.

April 10, 1967

The Apollo 204 Review Board testified before the Subcommittee on NASA Oversight of the House Committee on Science and Astronautics in morning, afternoon and evening sessions. Appendices D 1-4 and D 6-10 were delivered to the Administrator.

April 11, 1967

The Apollo 204 Review Board testified before the Senate Committee on Aeronautical and Space Sciences in morning and afternoon sessions. Following that testimony the Board convened in the Management Review Center, NASA Headquarters, to review and edit the transcript of the House Hearings conducted on April 10.

April 12, 1967

The Board convened in the Management Review Center, NASA Headquarters, to review and edit the transcripts of the Senate Hearings conducted on April 11. At twelve noon, the Board was recessed by the Chairman subject to being reconvened at the call of the Chairman, and the Members returned to their respective offices to resume their normal duties.

April 14, 1967

The Chairman by TWX delegated Board Member Colonel Frank Borman to act in the Chairman's behalf when the Subcommittee on NASA Oversight visited KSC on April 21, 1967. Preparation of errata sheets to the Report began.

April 18, 1967

The errata sheets were completed and delivered to NASA Headquarters. The first shipment of official Board files was sent from KSC to LRC.

April 21, 1967

The Subcommittee on NASA Oversight of the House Committee on Science and Astronautics visited KSC. The following members were in attendance: Congressmen Teague, Hechler, Daddario, Fulton, Gurney, Wydler, Vander Jagt. Subcommittee Staff Members in attendance were: Messrs. Ducander, Gerardi, Wilson. Dr. Mueller was represented by Messrs. Freitag and Holcomb; Mr. Callaghan was represented by Mr. Cramer. After visiting LC 34 and the VAB, the Subcommittee spent approximately one hour in



the PIB. Board Member Colonel Frank Borman conducted the briefing held in the PIB. At the request of Chairman Teague the Subcommittee viewed a display of the astronauts' suits in Room 106 of the PIB. Following luncheon in the KSC Director's conference room, the Subcommittee (and various members of NASA Management) convened in Room 1814 MSOB to hear the last six minutes (approximately) of the S-Band voice transmission prior to and at the time of the accident. Colonel Frank Borman provided necessary explanations of sounds and answered questions. At the conclusion of this session (approximately fifteen minutes duration) the Subcommittee began open hearings in the Mission Briefing Room, MSOB. The Subcommittee departed KSC at 3:30 p.m.

April 25, 1967

Shipment of the remaining Official Board Files, including the Photo Library Files, to LRC from KSC was accomplished.

May 9 - 10, 1967

The Chairman, at the request of the Administrator, attended the hearings before the Subcommittee on NASA Oversight on May 9 and the Senate Aeronautical and Space Sciences Committee on May 10 covering the response of the Administrator and the Apollo Program Management to the Board's Report.

May 12 - 16, 1967

By TWX dated May 12, 1967, the Chairman appointed a subcommittee to examine the final report of Panel 18 and prepare recommendations regarding its acceptability for inclusion in Appendix G of the Board's Report. The membership of the subcommittee consisted of:

Dr. Maxime A. Faget, Chairman  
Colonel Frank Borman  
Mr. George C. White, Jr.  
Mr. E. Barton Geer

The subcommittee was also requested to review the comments of the North American Aviation, Inc. relative to the validity of the findings, determinations and recommendations of the Board and its Panels. The subcommittee met at Manned Spacecraft Center, Houston, on May 16, 1967, and after review of the Panel 18 reports, recommended that they be accepted by the Board; and secondly, after review of the comments of North American Aviation, advised the Chairman that none of the Board's or Panel's findings, determinations and recommendations need be withdrawn or modified.

May 22, 1967

The Chairman, in a telephone conversation with Dr. Robert W. Van Dolah, briefed him on the progress of completion of the work of the Board, particularly with regard to the acceptance of the final reports of Panel 18 to be published in Appendix G. The Chairman advised Dr. Van Dolah that, with the concurrence of all Board Members, he will advise Dr. Seamans by letter that the work of the Board has been completed and request that the Board be dissolved.

May 23, 1967

The Chairman, in a telephone conversation with Colonel Charles F. Strang and John J. Williams briefed each of them on the progress of completion of the work of the Board particularly with regard to the acceptance of the final reports of Panel 18 to be published in Appendix G. The Chairman advised Colonel Strang and John Williams that, with the concurrence of all Board Members, he will advise Dr. Seamans by letter that the work of the Board has been completed and request that the Board be dissolved.

May 24, 1967

The materials in the Official Board's File at Langley Research Center are being indexed and catalogued. It is anticipated that this will be accomplished by the end of June 1967.

SECTION 2

CHRONOLOGY OF CONGRESSIONAL CORRESPONDENCE



I. CHRONOLOGY OF CORRESPONDENCE SUBMITTED TO THE  
AERONAUTICAL AND SPACE SCIENCES COMMITTEE, UNITED  
STATES SENATE

On April 14, 1967, the Chairman of the Apollo 204 Review Board addressed a letter to the Chairman, Aeronautical and Space Sciences Committee, United States Senate answering a request from Senator Smith to submit for the record the Chairman's own opinion as to where the NASA's management structure the major deficiency lies with respect to the failure to recognize and to correct the serious deficiencies noted in the Board's Report. Attachment 1 is the letter to the Committee in response to that request.

Another request by Senator Smith was for the Board to submit to the Senate Aeronautics and Space Sciences Committee a summary of the report furnished to the Board by a former North American Aviation, Inc. employee, Thomas R. Baron. The requested summary was furnished the Committee by letter dated April 18, 1967, with enclosure, Attachment 2.

At the end of the Hearings held on April 11, the Committee Staff Director requested the Counsel to the Board to furnish him the organizational structure of North American Aviation. This was furnished by letter dated April 18, 1967, Attachment 3.

These three submittals constitute all the submissions requested by the Senate Committee for inclusion in the record of the Hearings.

II. CHRONOLOGY OF CORRESPONDENCE SUBMITTED TO THE COMMITTEE  
ON NASA OVERSIGHT, COMMITTEE ON SCIENCE AND ASTRONAUTICS,  
HOUSE OF REPRESENTATIVES

In response to requests by Congressman Ryan to submit correspondence from the Safety Office, Kennedy Space Center, pertaining to timely submittals of operational checkout procedures for review, the requested correspondence was submitted to the Chairman by letter dated April 19, 1967, Attachment 4.

The letter transmitting the correspondence requested by Congressman Ryan for the record also furnished data requested by Congressman Winn with respect to the time lag in recording Engineering orders, Attachment 4.

During the course of the Hearings before the Subcommittee, Congressman Fulton desired that the previous history of electrical arcing be put in the record and also what the inferences and responses were from that history. By letter dated April 19, 1967, Counsel to the Review Board furnished the Associate Administrator for Legislative Affairs the requested history with a letter of transmittal to the Chairman of the Subcommittee signed by the Chairman of the Review Board, Attachment 5.

During the Hearings held on April 10, 1967, Congressman Rumsfeld requested the Board to submit information as to who was responsible for the various elements of ground emergency procedures that were stated in the Findings and Determinations on Pages D-13-11 to D-13-13 of Appendix D to the Board's Report. By letter dated April 27, 1967, the Chairman of the Apollo 204 Review Board transmitted the requested information to the Chairman of the Subcommittee on NASA Oversight. This letter was transmitted to NASA Headquarters, Code C by the Counsel of the Review Board on April 27, 1967, Attachment 6.

These three submittals constitute all the submissions requested by the Subcommittee on NASA Oversight for inclusion in the record of the Hearings.



NATIONAL AERONAUTICS AND SPACE ADMINISTRATION

APOLLO 204 REVIEW BOARD

April 14, 1967

IN REPLY REFER TO

Honorable Clinton P. Anderson  
Chairman, Aeronautical and Space Sciences Committee  
United States Senate  
Washington, D. C.

Dear Senator Anderson:

During hearings held on April 11, 1967, before your Committee, Senator Smith asked me to submit for the record my own opinion as to where in NASA's management structure the major deficiency lies with respect to the failure to recognize and to correct the serious deficiencies noted in the Board's report.

In my opinion, the overall organization structure of the Apollo program, both Government and Contractor, is sound. What I, personally, and the other Board members were concerned about were the procurement/inspection/checkout/acceptance processes of Apollo spacecraft at lower levels of management. I felt that this was a weakness within the structure that should be looked into by the top management of NASA. The accomplishment of this objective must face the difficulties of dealing with the dynamic requirements of a fast moving program. When you consider that two NASA Centers, Manned Spacecraft Center and Kennedy Spacecraft Center, and two Contractor facilities, North American Aviation, Downey and North American Aviation, Florida facility must, of necessity, coordinate the total effort, it is not difficult to discover areas where the administrative, engineering, and operational procedures may show defects.

The Board described the management and organization of the Apollo program in Appendix E of its report to the Administrator, NASA. In its report, the Board set out in considerable detail

the management and responsibility levels. However, no attempt was made to ascertain the actual working relationships as they currently exist between the various management levels. The Board did not consider itself to be charged with the responsibility of management analysis. Furthermore, if it had, the investigation would have taken several more months.

If any management level is to be charged with the failure to recognize and correct the deficiencies noted in the Board's report, it would be the design and layout engineering level. I pointed out in my testimony and it is a matter of record that the Board and I were seriously concerned with the electrical wiring and soldered joints. I specified the material to you in my testimony and referred you to page 6 of Appendix D-9 of the Report. I believe that when the wiring and plumbing joint problem is solved by the Apollo Program Office, coupled with the recommended reduction of flammable material, the reliability of the Apollo spacecraft will be increased to an acceptable level not only for safety, but for mission success.

Sincerely yours,

Original signed by

Floyd L. Thompson  
Chairman, Apollo 20<sup>4</sup> Review Board



April 18, 1967

Honorable Clinton P. Anderson  
Chairman, Aeronautical and Space Sciences Committee  
United States Senate  
Washington, D. C.

Dear Senator Anderson:

During the hearings held on April 11, 1967, before your Committee, Senator Smith asked me if I would be able to get a summary of Baron's report and give it to the Committee. I assured Senator Smith that I would. Attachment No. 1 is the requested summary.

Sincerely yours,

Floyd L. Thompson  
Chairman, Apollo 204  
Review Board

Enclosure

FLT)  
GTM):scw 4-18-67

ATTACHMENT NO. 1

During the course of the Apollo 20<sup>4</sup> Review Board investigation, a 58-page document called "An Apollo Report" was furnished to the Board by a Mr. Thomas R. Baron, a former North American Aviation, Inc., Quality Control Inspector and Receiving Inspection Clerk. This document was severely critical of North American Aviation's conduct of the Apollo project. Mr. Baron was requested to testify to the Board about his allegations which he did on February 7, 1967. In addition, he furnished a 275-page document entitled "The Baron Report." The testimony before the Board and the 275-page document reiterated and set out in more detail the allegations originally made against North American Aviation, Inc., in the 58-page document.

The criticisms levied by Mr. Baron at his former employer, North American Aviation, Inc., can be grouped into five (5) categories: (1) quality control, (2) safety, (3) records and documentation, (4) personnel, and (5) operations. These allegations are summarized in the following:

1. QUALITY CONTROL:

Throughout the report, allegations are made of generally poor workmanship observed by Baron. Because of faulty quality control procedures, unacceptable workmanship was often missed by inspectors. When he himself observed defects which he was unwilling to pass, Baron would report these to his supervisors. The report details various instances where nothing was done to correct the deficiencies he noted. Specific examples of poor quality workmanship discussed in the report are faulty installation of spacecraft 012 heat shield; faulty installation of spacecraft 009 rendezvous window; poor workmanship in splicing on the quads; and unsatisfactory water glycol operations in ground support.

The report is also critical of test and inspection procedures, alleging that tests were frequently conducted by unqualified personnel using equipment not suited for the particular test being conducted. The failure of NASA personnel to participate in many of these tests and to maintain a general cognizance of the daily workings on the project has, in Baron's opinion, made such lax procedures possible.

## 2. SAFETY:

Baron alleges that the general level of safety on the project site was low. Lack of sufficient standards was a factor, which together with supervisory and employee carelessness contributed to the hazards he observed in the operations. Among the particular hazards he details are permitting smoking during and immediately after hazardous operations; conducting fuel operations to diesel power unit when oxidizer transfer unit operation was being conducted; leaving open drains at various levels of pad 34; absence of nets and chain rails to safeguard men working at different levels of the gantry; nonoperating elevators for emergency egress; falling objects endangering personnel on the ground; and operating of high pressure valves without proper protection.

## 3. RECORDS AND DOCUMENTATION:

In several areas, there are no procedures established for uniform record keeping. Where records are maintained, they vary from technicians notes to standard printed forms. Because of this lack of uniformity, it is possible to initiate relatively major alterations on the systems without these alterations ever being documented for future reference. An example of this situation is seen in the removal and replacement of parts in the coolant system without proper documentation. Where record keeping procedures are fairly well established, the procedures are often grossly inefficient. Parts distribution is an example of this inefficiency. Forms used for this are printed in two copies. One copy is torn off and thrown away without ever being used.

## 4. PERSONNEL:

Personnel working on the project are shifted from one job to another before acquiring extensive familiarization with the particular project on which they are working. This prevents technicians from becoming "professional" and hinders their opportunities for advancement in the company.

Personnel control is generally poor; technicians at times standing around with nothing to do, while at other times, there was a lack of technicians for a given task. Work that should have been done by experienced mechanics was done by NASA Quality Control personnel and engineers would from time to time perform functions that the technicians should have been performing. Some phases of the work were improperly supervised, there being no qualified engineer on the project site.

These and several other personnel problems contributed to the lowering of morale among North American Aviation employees and a resultant reduction of efficiency.

5. OPERATIONS:

The Baron Report alleges a "Lack of coordination between people in responsible positions" and a "lack of communication between almost everyone." More specifically, he alleges a failure to provide official tie in periods for work; scheduling of work in areas so nearby as to cause almost certain contamination; and difficulty in determining whether meter calibrations are up to date.

April 18, 1967

James J. Gehrig, Esq.  
Staff Director, Aeronautical and Space Sciences Committee  
Room 231, Senate Office Building  
United States Senate  
Washington, D. C.

Dear Jim:

Transmitted herewith is the North American Aviation, Inc., organizational structure together with a brief narrative of the organization and management of the Apollo Command and Service Module Program. I finally received the package at 1:20 p.m. I hope you get it in time for the Committee print.

Sincerely yours,

George T. Malley  
Counsel, Apollo 20<sup>4</sup> Review Board

Enclosure

## DIRECTION AND CONTROL OF

### APOLLO COMMAND-SERVICE MODULE (CSM) PROGRAM

#### I. Organization and Management of Apollo CSM Program

North American Aviation (NAA), by the nature of its organization and the policy of its management, makes available to the customer the full resources of the company in support of the Apollo CSM Program. Program management has been assigned to direct and control the Program to satisfy customer technical, schedule, and cost requirements.

##### A. Corporation

The Space and Information Systems Division (S&ID), which is responsible for the Apollo CSM and Saturn II Programs is one of seven NAA operating divisions supported by corporation administrative organizations. Each division is headed by a division president who is also a vice president of the corporation responsible to NAA President, J. L. Atwood. Mr. Atwood is also Chairman of NAA's Board of Directors. The corporation establishes and administers the broad policies which constitute the framework within which each operating division functions. Chart "X" shows the NAA corporate organization.

##### B. S&ID

S&ID is headed by Division President, H. A. Storms. This division is responsible for the Apollo CSM and Saturn II Programs which are being carried out under separate program managers. The Apollo CSM Program is directed by Apollo CSM Program Manager and S&ID Vice President, D. D. Myers, who is responsible to both NASA and Division President, H. A. Storms. Advanced Programs Development, and Research, Engineering and Test furnish special technical support as needed. Other S&ID functions provide administrative support - Chart "Z" shows the S&ID organization.

##### C. Apollo CSM

As shown in Chart "L," the Apollo CSM Program Manager, D. D. Myers, is assisted by Deputy Program Manager, C. H. Feltz, and four Assistant Program Managers. Directors of four functional areas report directly to the Program Manager. The Director of Quality and Reliability Assurance is responsible to the Program Manager in technical matters although reporting administratively to the S&ID Director of Quality and Reliability Assurance. The Director of Apollo CSM Operations, Florida, J. L. Pearce, is responsible to the Apollo CSM Program Manager although he reports administratively to the NAA General Manager of the Florida Facility, W. S. Ford. This organizational plan gives the Apollo CSM Program

Manager direct control and responsibility over all phases of the Program including all subcontracting, which is administered by Apollo material.

D. Florida Facility

The overall Florida Facility organization is shown in Chart "Q," and the Apollo CSM Florida organization, in Chart "E." The Apollo CSM Florida Director, J. L. Pearce, is supported by three managers, the Chief Project Engineer, R. W. Pyle, and the Technical Support Chief, R. E. Franzen. The three managers have separate areas of responsibility: Test Operations, J. M. Moore; Test Sites, R. E. Barton; and Quality and Reliability Assurance, J. L. Hansel. Very close liaison and control between Downey and Florida Apollo CSM operations is maintained.

II. Program Hardware Responsibility

S&ID is responsible, with NASA concurrence, for the overall development, design, manufacture, and test of Apollo CSM hardware.

A. Spacecraft Configuration

The Apollo CSM configuration is shown in Chart ZZ. S&ID is responsible for the command and service modules, the launch escape system, the spacecraft/lunar module adapter, and most subsystems pertaining to these modules. S&ID is responsible for coordinating the physical and operating interfaces of these modules and systems with the Associate Contractors (shown in Chart LC), and NASA.

B. Ground Support Equipment (GSE)

NAA supplies GSE as directed by NASA to support Apollo CSM test and checkout operations at all test sites. This GSE consists of checkout equipment, auxiliary equipment, servicing, and handling equipment. NAA is responsible for the design, manufacture, and checkout of this GSE.

C. Subsystems

The following Apollo CSM subsystems and modules are being produced inhouse at NAA:

<u>Subsystem or Module</u>	<u>Division</u>
Command and Service Modules (Complete)	S&ID
SLA (Complete)	S&ID
Launch Escape System Structure	Los Angeles Division
Sequencer System	Autonetics
Command Module Reaction Control System	Rocketdyne

Units that are made at other NAA divisions are designed, manufactured, and tested under S&ID supervision and control.

D. Subcontractors

Major and minor subcontractors are selected with NASA concurrence by S&ID, and are under S&ID surveillance. The subsystems they fabricate are designed, manufactured, and tested under S&ID supervision and control. Chart R shows the Apollo CSM major subcontractors and the systems for which each is responsible.

E. Suppliers

S&ID buys hardware for the Apollo CSM Program directly from over 12,000 first-tier suppliers of which 9,600 represent small business; and the remainder, large business. All such hardware must be bought from S&ID approved sources and the hardware must be certified and tested as required to meet applicable specifications. Suppliers of these first-tier suppliers represent many thousands of additional firms.

III. Program Control Procedures

- A. The baseline for NASA and NAA management of the program is contained in the contract. The particular control baselines are the technical, master end item and specific end item specifications, the contract plans, and contract change notices which become incorporated into the baselines by specification and supplemental agreements. The controlling plans are the Manufacturing Plan, the Quality Control Plan, the Configuration Management Plan, the Ground Operations Requirement Plan and the Reliability Plan.

B. Control Tools - Cost, Schedule and Quality

Program control procedures are implemented only after formal Joint NASA/NAA interface agreements. These interfaces consist of contractual, technical and schedule meetings and documentation. Contractual direction is given by NASA to NAA through (bilateral) Supplemental Agreements and Contract Specification Change Notices and through (unilateral, by NASA) Contract Change Authorizations, Technical direction is given by NASA through Program Management Meetings, letters and wires to the NAA contracting officer and in formal reviews and Interface Control Documents. Formal joint reviews are Preliminary and Critical Design Reviews (PDR's and CDR's), First Article Configuration Inspection (FACI), Customer Acceptance Readiness Reviews (CARR) and Flight Readiness Reviews (FRR).

Through the S&ID Apollo CSM Program Manager's Office, control is exercised over CSM program costs, schedule and quality. The control media include the following:



1. Cost Control is provided primarily through Joint NASA/NAA negotiated and approved "work packages" with individual work package managers assigned to control costs, schedule achievements and quality. The choice of work package breakdown structure has enabled individual cost control of functional elements within S&ID as well as major subcontractors which supply CSM subsystems. NASA, NAA division and corporate policies assure proper make or buy decisions, subcontractor bid selection, and the like.
2. Schedule Control is provided by use of a "Master Development Schedule," a formal schedule change system, a PERT reporting system of scheduled milestones and formal critical problem reports. Major schedule changes receive concurrence of the NASA Program Manager prior to NAA implementation. The selection of schedule milestones, monitored by PERT are also identified in the cost control work packages, yielding an integrated cost/schedule measuring device.
3. Control of Quality is provided by (a) jointly approved hardware qualification test-selection, criteria, test surveillance and test report approval, (b) Joint NASA/NAA mandatory inspection point assignments and surveillance, and (c) step-by-step inspections (NASA/NAA) through manufacture, checkout and prelaunch operations. A failure reporting system assures follow-up on potentially discrepant hardware. Control of subcontractor quality is provided in a similar fashion, with NAA and NASA approvals obtained as described in paragraph E.

#### C. Management Control Documents

Management control documents for Apollo CSM hardware exist at both the program level and at the first-line level of NAA S&ID management. The top documents serve to record design and product certification and flight readiness. These are the jointly approved minutes of PDR, CDR, FACI, CARR, Design Certification Review (DCR) and FRR.

The first-line level management control documents are:

1. Design - Master Change Records (MCR), drawings, process specifications, interface control documents and measurement lists.
2. Manufacturing - Fabrication and inspection record tickets, tool orders and parts replacement requests.
3. Material (Purchasing) - Purchase order, purchase order change notice and specification control documents.

4. Test and Operations - Operational test plan, operational checkout procedure, not satisfactory report, test preparation sheet, development test procedure.
5. Quality and Reliability Assurance - Inspection test instructions, material review disposition and quality control specifications.

D. Configuration Management

Configuration Management is practiced through compliance with the NASA Apollo Configuration Management Manual and NAA Division Policies as implemented by the Apollo CSM Change Control Board, chaired by the Assistant Program Manager. Configuration changes with major program impact are resolved at Joint Change Control Board meetings between the NASA and S&ID Program Managers.

Changes imposed on program baselines originate from both NASA and NAA. NASA directed changes are processed by Contracts through the Change Control Board for preparation of proposals. Inhouse changes are processed by the Apollo CSM chief project engineer also through the Board for evaluation and direction. Change control documentation is in the form of a Master Change Record (MCR) which defines the change and is the basis of an order to the functional departments to provide cost and schedule information for necessary evaluation, prior to final implementation. The MCR can be used, as above, to determine details of a change prior to implementation; however, for urgent changes the purpose of the MCR is to initiate action, which is accomplished upon MCR approval by Program Management for "Release to Production."

Configuration records are maintained in mechanized records of released engineering drawings and specifications. These records provide indentured drawing lists, parts lists and alpha-numeric parts or drawing lists. The manufacturing planning system assures drawings and engineering order (E.O.) compliance utilizing Fabrication and Inspection Records (FAIR) and a Change Verification Record (CVR) for each end item. The FAIR provides both fabrication instructions and inspection verification; the CVR provides E.O. records and verification of compliance.

During Downey, Houston and Florida testing, a Test and Inspection Record (TAIR) system provides identical configuration and inspection information.

- E. Subcontractor control baselines consist of (a) approved design specifications, drawings, components, qualification test plans and reports, acceptance test plans, critical process specifications, and component failure histories. A FACI is conducted for complex

(major) procurements by S&ID with an NASA audit. Other procurements are subjected to FOCI at NAA, utilizing subcontractor data. All baselines are reverified to NASA at the SC 101 (Block II lunar capable vehicle) FOCI.

Conformance of the subcontractors is controlled by "freezing" component changes at FOCI, strict part number control, identification and reidentification, source or receiving inspection to formally approved drawings and baselines and component repair or overhaul, controlled to the configuration specified in the approved baseline.

Changes are justifiable only for NASA or NAA requirements modifications; failure in qualification, during production or in operational tests; or for significant cost reduction. Change controls parallel the NASA-S&ID change control procedures. This method of subcontractor control is in effect at such major subcontractors as Honeywell, AiResearch, Beech, and Pratt and Whitney.

#### F. Field Site Control

Apollo CSM Program Field Site efforts with activities at Florida, MSC-Houston, White Sands, New Mexico, and El Centro, California, are managed as are similar efforts in Downey. The management differences are caused by the fact that hardware at field sites has usually been transferred to NASA owned, and also is governed by NASA field site management procedures, rather than NAA or NASA-MSA.

Hardware flow through the field site is controlled by the Ground Operations Requirement Plan (GORP) contractual document, as modified by operational changes and deviations approved by the NASA-KSC or other field site change board.

Hardware changes evolving from NASA and NAA sources, identified previously, are processed through the Downey system for incorporation in a similar manner to other changes.



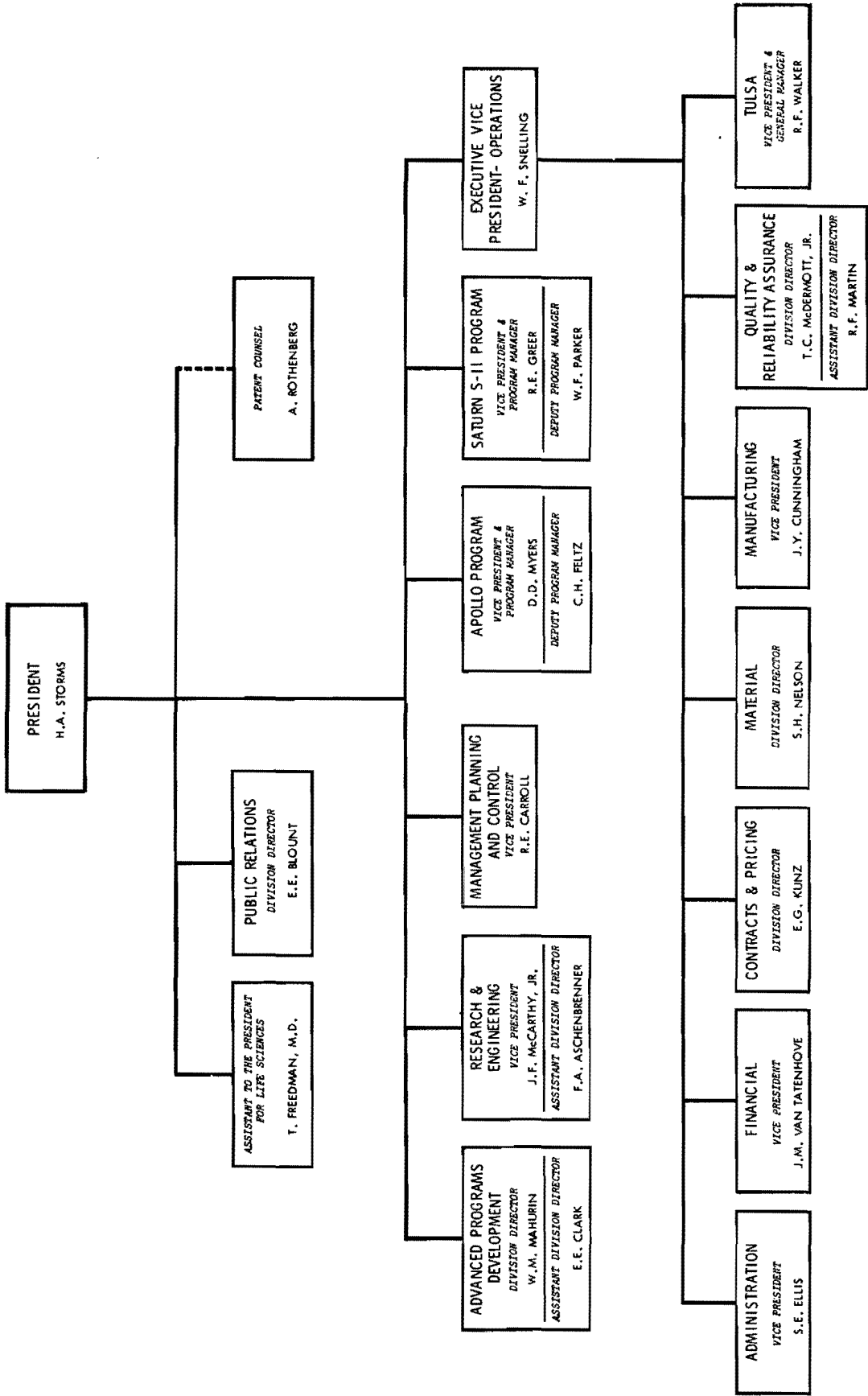



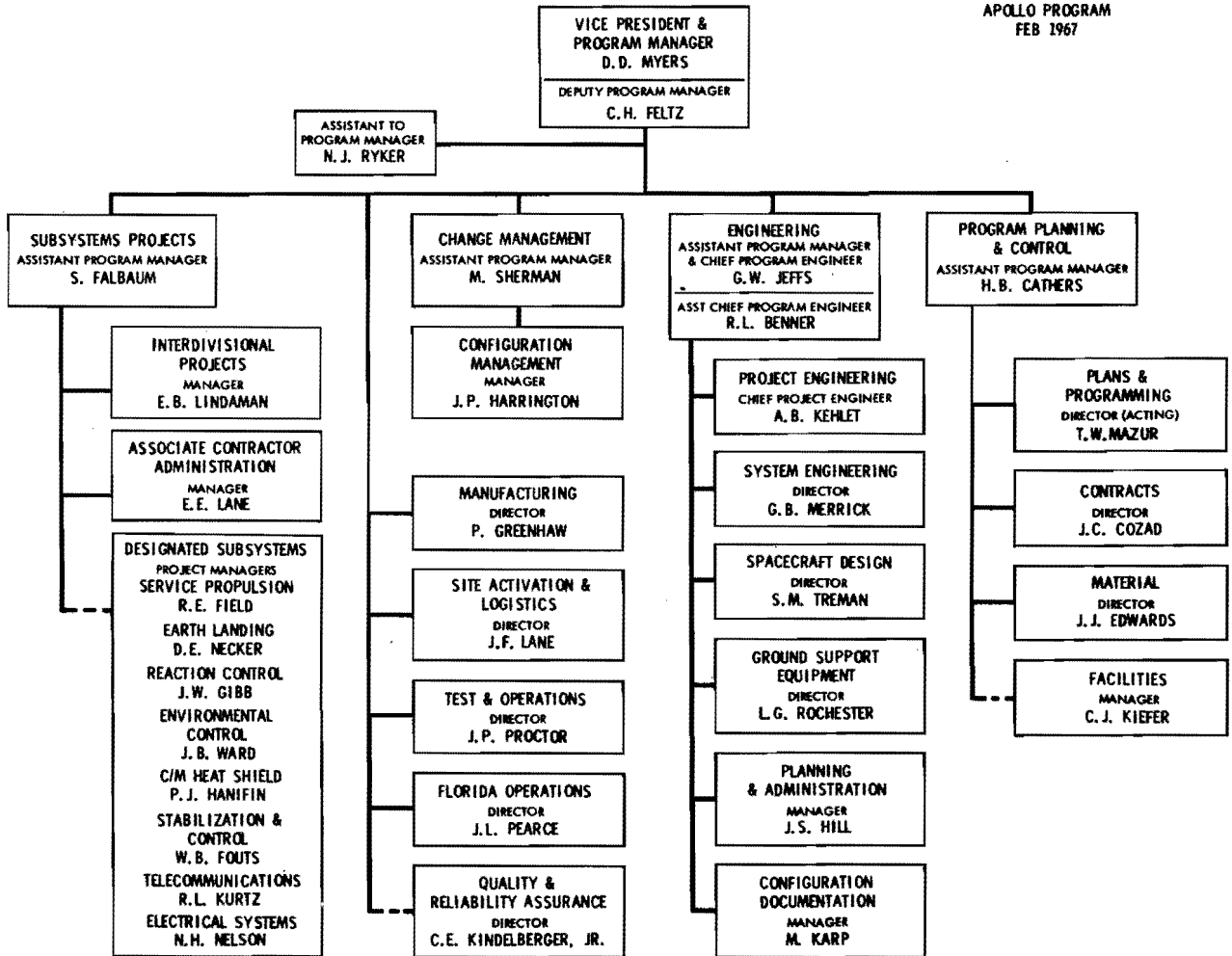

## APOLLO ASSOCIATE CONTRACTORS

MIT	GUID & NAV EQUIP. - TECH MGMT
AC ELECTRONICS	GUID & NAV EQUIP. - MFG
CHRYSLER	S-I
BOEING	S-IC
NAA S&ID	S-II
DOUGLAS	S-IV & S-IVB
GENERAL ELECTRIC	ACCEPTANCE CHECKOUT EQUIP.
GRUMMAN	LUNAR MODULE
HAMILTON	
STANDARD	SPACESUIT & PORTABLE EQUIP.



# APOLLO SPACECRAFT

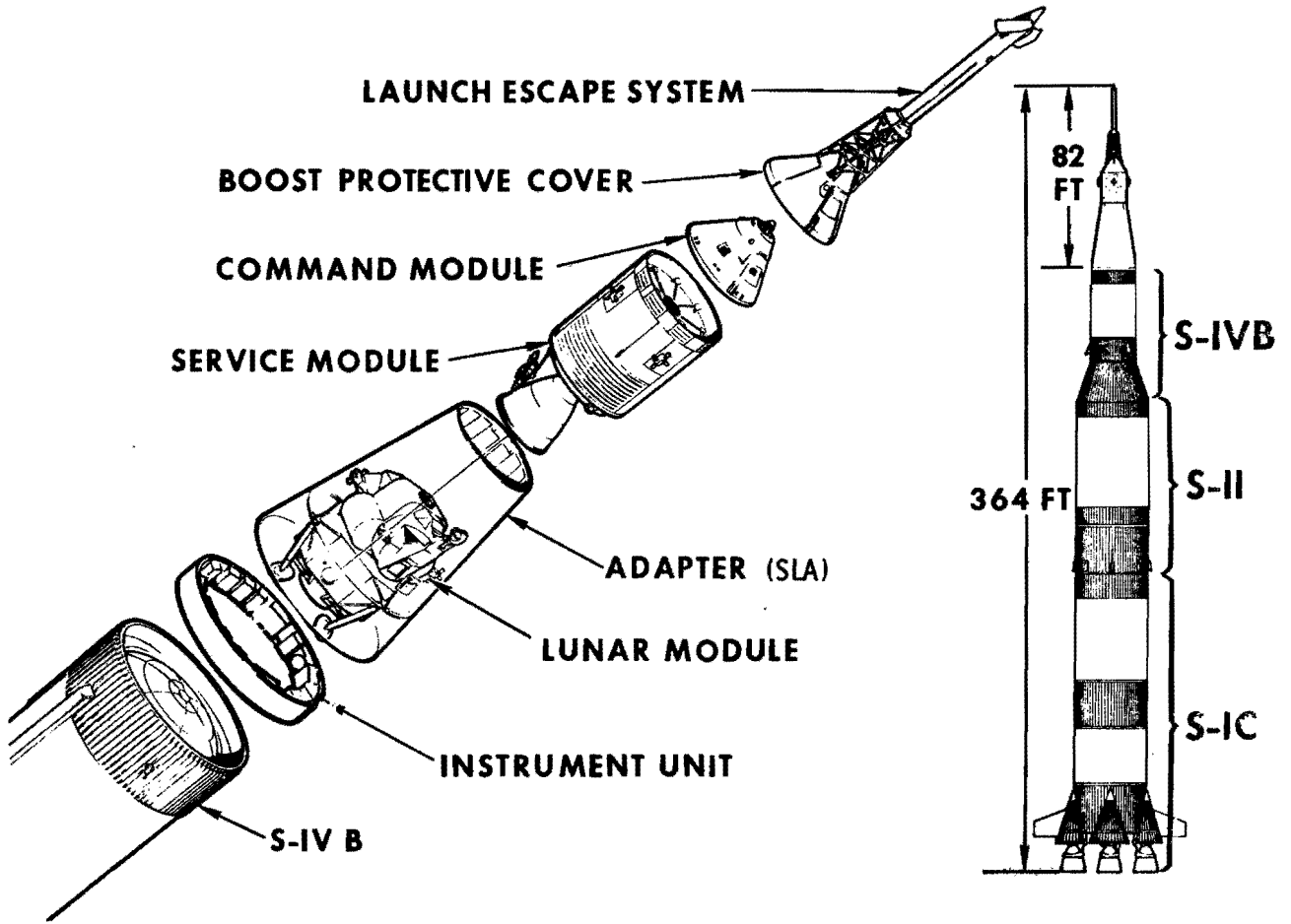

## APOLLO MAJOR SUBCONTRACTORS

### SUBSYSTEM

SERVICE MODULE PROPULSION MOTOR

CM HEATSHIELD BRAZED STRUCTURE  
PANELS

ABLATIVE HEATSHIELD

SUPER CRITICAL GAS STORAGE

COMMUNICATIONS AND DATA

ENVIRONMENTAL CONTROL

MISSION SIMULATOR TRAINER

STABILIZATION AND CONTROL

LAUNCH ESCAPE AND PITCH CONTROL  
MOTORS

REACTION CONTROL MOTORS (SERVICE  
MODULE)

EARTH LANDING

ESCAPE TOWER JETTISON MOTOR

FUEL CELL

### SUBCONTRACTOR

AEROJET-GENERAL CORPORATION

AERONCA MFG CORPORATION

AVCO CORPORATION, RESEARCH & ADVANCED  
DEVELOPMENT DIVISION

BEECH AIRCRAFT CORPORATION

COLLINS RADIO COMPANY

GARRETT CORPORATION, AIRESEARCH MFG.  
DIVISION

GENERAL PRECISION, INC. LINK DIVISION

HONEYWELL

LOCKHEED PROPULSION COMPANY

THE MARQUARDT CORPORATION

NORTHROP CORPORATION, VENTURA DIVISION

THIOKOL CHEMICAL CORPORATION, ELKTON  
DIVISION

PRATT & WHITNEY AIRCRAFT, DIVISION OF  
UNITED AIRCRAFT CORPORATION

April 19, 1967

TO: NASA Headquarters, Code C  
Attention: Richard L. Callaghan

FROM: Counsel, Apollo 204 Review Board

SUBJECT: Correspondence regarding Safety Office review of tests

Pages 198, 200-202, Volume 1-A of the stenographic transcript of the hearings before the NASA Oversight Subcommittee concern themselves with Congressman Ryan's questions with regard to Kennedy Space Center Safety Office correspondence relating to review of tests, and the Chairman's request that the correspondence be furnished for the record. The enclosure is all the available correspondence sent up by Kennedy Space Center to me for transmission to the Oversight Subcommittee.

On page 255 of the transcript, lines 22 and 23, Congressman Winn was told that the time lag in recording engineering orders would be furnished. The answer is provided in the text of the letter to the Chairman.

George T. Malley

Enclosure

GTMalley:scw 4-19-67

April 19, 1967

Honorable Olin E. Teague  
Chairman, Committee on Science and Astronautics  
Subcommittee on NASA Oversight  
House of Representatives  
Washington, D.C. 20515

Dear Mr. Chairman:

During the course of the hearings, Congressman Ryan stated that it would be helpful for the record to show correspondence from the Safety Office, Kennedy Space Center, pertaining to timely submittals of operational check out procedures for review. The Chairman then requested that such information be furnished for the record. In compliance with that request the correspondence is transmitted herewith.

Later on Congressman Winn wanted to know the time lag in recording engineering orders, originating at North American, Downey, in the Configuration Verification Record Book maintained at Kennedy Space Center. The best recorded time for a North American spacecraft engineering order to be received and recorded in the Configuration Verification Record Book is two days after release in Downey. The average time is between five and seven days.

Sincerely yours,

Floyd L. Thompson  
Chairman, Apollo 204 Review Board

Enclosure

GTMalley:scw 4-19-67

Chief, Test and Operations Management Office, KE

Chief, Safety Office, RE

RE-1/471/Barnett:mr  
867-3973

Operations Checkout Procedures for KSC Safety Review

1. Review of NAA S/C 017 OCP status dated September 16, 1966, indicates that the allowable time between OCP publication and test date is only 6 days.
2. KSC Safety has repeatedly requested 30 days for review of procedures, but to date, a workable solution has not been established to assure our receiving the procedures by the required date.
3. The present schedule for S/C 017 OCP publication is not acceptable to KSC Safety. RE-1 must have a minimum of 14 working days to give the procedures proper review.
4. RE requests that your office initiate action to eliminate the aforementioned problem.

Original signed by  
John R. Atkins

May 2, 1966

Chief, Operations Safety Branch, QAS-23

QAS-23/131/Barnett:mr  
867-4317

OCP-PO-K-4620, GO<sub>2</sub> Servicing System Test, and OCP-PO-K-4621, GH<sub>2</sub> Servicing System Test

1. Subject procedures were received on the morning of May 2, 1966, with the cover letter stating that the tests were scheduled for May 2 and 4, 1966.
2. It is not normal for this office to approve a flimsy copy of the checkout procedures. We can make comments on flimsy copies, but it appears that most procedures are changed before they are published in the hardback copy.
3. The two subject procedures do not have a NASA Systems Engineer's signature, so we must assume that the NASA Systems Engineers do not approve the procedures.
4. By receiving these procedures with only one day to review them, this office cannot review them properly.
5. These two procedures will not be reviewed nor approved until a NASA Systems Engineer's signature has been affixed.
6. Further flimsy copies of any procedure will not be approved by this office. We will submit comments only to flimsy copies.
7. These two tests do not have KSC Safety approval at this time, and KSC Safety will not condone the running of these tests with GO<sub>2</sub> and GH<sub>2</sub> in the MSO until we have received and reviewed the proper procedure.

Original signed by  
John T. McGough

Requirements & Analysis Branch, KG-1

Chief, Operations Safety Branch, RE-1

RE-1/460/Barnett:mr  
867-3973

Apollo S/C 017 OCP Request for KSC Safety Review

1. Please submit the attached List (Encl. #1) of Operations Checkout Procedures to KSC Safety for review and approval. Encl. #2 contains a list of OCPs which RE-1 requires for update.
2. Review of NAA S/C 017 OCP Status dated September 16, 1966, indicates that the allowable time between OCP publication and test date is only 6 days. KSC Safety has repeatedly asked for 30 days for review of procedures, but a workable solution has not been established to get those procedures to us by the required date.
3. The present schedule for S/C 017 OCP publication is not acceptable to KSC Safety. RE-1 must have a minimum of 14 working days to give the procedures proper review. Request your office initiate action to get those procedures to RE-1 with sufficient time allowed for proper Safety review.

Original signed by  
John T. McGough

Enclosures  
as stated in para. 1

cc:  
R. Walker, BEN-3

KG-1 (559)

North American Aviation, Inc.  
Manned Spacecraft Operations Building  
Kennedy Space Center, Florida

Attention: Mr. J. L. Pearce

Gentlemen:

Subject: Apollo S/C 017 OCP Safety Review

The following listed Apollo S/C 017 OCP's are requested for KSC and Range Safety approval:

<u>OCP #</u>	<u>TITLE</u>
0005	Integrated Test with Launch Vehicle Simulator
0007	Countdown
0033	Countdown Demonstration
0038	S/C Hypergolic Loading
3112	LES/BPC to C/M Mate/Demate & Thrust Vector Alignment Verification
3116	S/C Transportation to VAB and Mate
4070	C/M RCS Functional and Leak Test
4074	SPS Functional and Leak Test
4617	S/C Ordnance Installation and Removal
4736	Fuel Cell Cryogenic Servicing, LC-39
4747	Propulsion GSE Leak Check
K-5114	Water Glycol Servicing System Test, VAB
K-4720	Helium Servicing System Test, ACE Control, MSS
K-4721	Helium Servicing System Test, Manual Control, MSS
K-4723	SPS Fuel Servicing System Test, Manual Control, MSS
K-4725	C/M RCS Fuel Servicing System Test, Manual Control, MSS
K-4727	SPS Oxidizer Servicing System Test, Manual Control, MSS
K-4729	S/M RCS Fuel Servicing System Test, Manual Control, MSS
K-4731	CSM RCS Oxidizer Servicing System Test, Manual Control, MSS
K-4732	LH <sub>2</sub> Servicing System Test, ACE Control, MSS
K-4733	LH <sub>2</sub> Servicing System Test, Manual Control, MSS
K-4734	LO <sub>2</sub> Servicing System Test, ACE Control, MSS
K-4735	LO <sub>2</sub> Servicing System Test, Manual Control, MSS



<u>OCP #</u>	<u>TITLE</u>
K-9187	LO <sub>2</sub> Mobile Storage Unit (SL4-065)
K-9188	LH <sub>2</sub> Mobile Storage Unit (SL4-066)
K-9885	Loading and Unloading SPS Propellant Unit (SL4-059) for Propulsion Test Complex and Launch Complexes
K-9886	Loading and Unloading SPS Propellant Unit (SL4-058) for Propulsion Test Complex and Launch Complexes
K-9941	Calibration of Propellant Mass Measuring System Using Oxidizer
K-9942	Calibration of Propellant Mass Measuring System Using Fuel
K-10027	GSE Evacuation and Reinstallation - LC-39, Pad A

The following listed Apollo S/C 017 OCP's are required for KSC Safety information and update:

<u>OCP #</u>	<u>TITLE</u>
3045	LES Build-up
3071	C/M - S/M Mate
3116	CSM/SLA Mating
4058	Electro Explosive Devices Receiving, Inspection, Storage and Pre-installation Checkout
4072	S/M RCS Functional and Leak Test
4079	SLA Ordnance Installation and Removal
4738	Pyro Verification Test

The North American Aviation, Inc. S/C 017 OCP status dated September 16, 1966, shows six (6) days between OCP publication and test date. This schedule is not acceptable to KSC Safety. For proper review of tests conducted at KSC, KSC Safety will require a minimum of fifteen (15) working days.

It is requested that NAA initiate action to assure KSC/SCO that the above listed procedures required for Safety approval be submitted with sufficient time for proper Safety review.

Your cooperation is appreciated.

Sincerely yours,

Ernest N. Sizemore  
Chief, Planning & Technical  
Support Office

cc:

G. Schrooder, NAA Safety

KSC copies only, noted: W. E. Williams, KE  
J. Janokaitis, KE-1  
A. Morse, DJ  
A. Busch, KB  
G. Sasseen, KC

JVS:mbr 10/8/66

UNITED STATES GOVERNMENT

# Memorandum

TO : Requirements & Analysis Branch, KG-1

DATE: Sept. 30, 1966

FROM : Chief, Operations Safety Branch, RE-1

RE-1/460/Barnett:mr  
867-3973

SUBJECT: Apollo S/C 017 OCP Request for KSC Safety Review

1. Please submit the attached list (Encl. #1) of Operations Checkout Procedures to KSC Safety for review and approval. Encl. #2 contains a list of OCPs which RE-1 requires for update.
2. Review of NAA S/C 017 OCP Status dated September 16, 1966, indicates that the allowable time between OCP publication and test date is only 6 days. KSC Safety has repeatedly asked for 30 days for review of procedures, but a workable solution has not been established to get these procedures to us by the required date.
3. The present schedule for S/C 017 OCP publication is not acceptable to KSC Safety. RE-1 must have a minimum of 14 working days to give the procedures proper review. Request your office initiate action to get these procedures to RE-1 with sufficient time allowed for proper Safety review.

John T. McGough

Enclosures  
as stated in para. 1

cc:  
R. Walker, BEN-8



OCPs FOR KSC SAFETY REVIEW AND APPROVAL

OCP NUMBER	OCP TITLE
0005	Integrated Test with Launch Vehicle Simulator
0007	Countdown
0033	Countdown Demonstration
0038	S/C Hypergolic Loading
3112	LES/BPC To C/M Mate/Demate and Thrust Vector Alignment Verification
3116	S/C Transportation to VAB and Mate
4070	C/M RCS Functional and Leak Test
4074	SPS Functional and Leak Test
4617	S/C Ordnance Installation and Removal
4736	Fuel Cell Cryogenic Servicing, LC-39
4747	Propulsion GSE Leak Check
K-5114	Water Glycol Servicing System Test, VAB
K-4720	Helium Servicing System Test, ACE Control, MSS
K-4721	Helium Servicing System Test, Manual Control, MSS
K-4723	SPS Fuel Servicing System Test, Manual Control, MSS
K-4725	C/M RCS Fuel Servicing System Test, Manual Control, MSS
K-4727	SPS Oxidizer Servicing System Test, Manual Control, MSS
K-4729	S/M RCS Fuel Servicing System Test, Manual Control, MSS
K-4731	CSM RCS Oxidizer Servicing System Test, Manual Control, MSS
K-4732	LH <sub>2</sub> Servicing System Test, ACE Control, MSS
K-4733	LH <sub>2</sub> Servicing System Test, Manual Control, MSS
K-4734	LO <sub>2</sub> Servicing System Test, ACE Control, MSS
K-4735	LO <sub>2</sub> Servicing System Test, Manual Control, MSS

OCP #	OCP TITLE
K-9187	LO <sub>2</sub> Mobile Storage Unit (SL4-065)
K-9188	LH <sub>2</sub> Mobile Storage Unit (SL4-066)
K-9885	Loading and Unloading SPS Propellant Unit (SL4-059) for Propulsion Test Complex and Launch Complexes
K-9886	Loading and Unloading SPS Propellant Unit (SL4-058) for Propulsion Test Complex and Launch Complexes
K-9941	Calibration of Propellant Mass Measuring System Using Oxidizer
K-9942	Calibration of Propellant Mass Measuring System Using Fuel
K-10027	GSE Evacuation and Reinstallation LC-39, Pad A

OCPs RE-1 REQUIRES FOR UPDATE

OCP #	OCP TITLE
3045	LES Buildup
3071	C/M-S/M Mate
3116	CSM/SLA Mating
4058	Electro Explosive Devices Receiving, Inspection, Storage and Pre-Installation Checkout
4072	S/M RCS Functional and Leak Test
4079	SLA Ordnance Installation and Removal
4738	Pyro Verification Test

Chief, Safety Division, QAS-2

Manager, Apollo CSM Operations, SCO-8

Transmittal of Apollo S/C 011 Technical Information

Ref: Your memo dated April 26, 1966, same subject

1. Based upon the information contained in the referenced memo, NAA was requested to prepare a package showing documents anticipated submittal date.
2. NAA's response is enclosed. It should be noted that in most cases the scheduled transmittal dates do not comply with the 30-day pre-test safety review requirement. It should be further noted that most of these cases concern documents previously approved for S/C 009 and that the content is virtually identical.
3. Due to the advanced schedule that has been initiated for S/C 011, it is our feeling that the dates presented by the contractor in the enclosure represent the "best possible" and cannot be improved.
4. If these dates are not satisfactory then the utilization of flimsy or advance copies for KSC and ETORS safety reviews must be reconsidered.
5. If this is unacceptable, QAS should contact PPR and negotiate the resulting S/V schedule impact.
6. This office will insure delivery of the documents to KSC Safety at the earliest possible date.

George T. Sasseen

Enclosure

cc:

G. F. Page, SCO-5  
J. Simmons, SCO-63  
H. E. McCoy, PPR-1  
A. E. Morse, PPR-12

May 9, 1966

66MF323

John F. Kennedy Space Center  
National Aeronautics and Space Administration  
Kennedy Space Center, Florida 32899

Attention Manager, Apollo CSM Operations (SCO-S)

Contract NAS 9-150, Safety Significant OCP's, Status of  
Transmittal of

In order that the current status of safety significant documentat on submittal for OSM 011 may be more fully understood, enclosures (1) through (5) are submitted for your attention. It should be noted that the only areas where NAA has not met the full 30 day safety review requirements are a limited number of OCP's as can be identified from enclosure (3). The under-support of the 30 day safety review is primarily a result of a facility ORD compression of 14 days and compression of the launch schedule. You are assured that NAA is making a determined effort to recover as much of the 30 day review time as possible and will continue this effort.

It may be to the advantage of the KSC Safety Office to reconsider its position of not reviewing advanced copies of OCP's in respect to those OCP's showing under-support. An advanced review in combination with the complete file of specifications and drawings, currently in possession of KSC Safety Office, plus the knowledge that in most instances the OCP is a rerun of L/C 009 procedures, may reduce review time on the final released OCP to a degree that schedule impacts can be avoided.

The NAA Apollo Systems Safety personnel will be most happy to assist in any way possible to support your safety personnel in their reviews of procedures.

NORTH AMERICAN AVIATION, INC.

/s/ J. L. Pearce

J. L. Pearce, Director  
Apollo CSM Operations  
Florida Facility  
Space & Information Systems Division

NOW:oad

- Enc. (1) Listing of Drawings (**not included**)  
(2) Listing of Specifications(**not incl.**)  
(3) Status of Safety Significant OCP's for S/C 011  
(4) Explosive Materials Loaded in Components (**not incl.**)  
(5) Range Safety Requirements, Apollo Site Activation(**not incl.**)

cc: (PPR-1) NASA-KSC

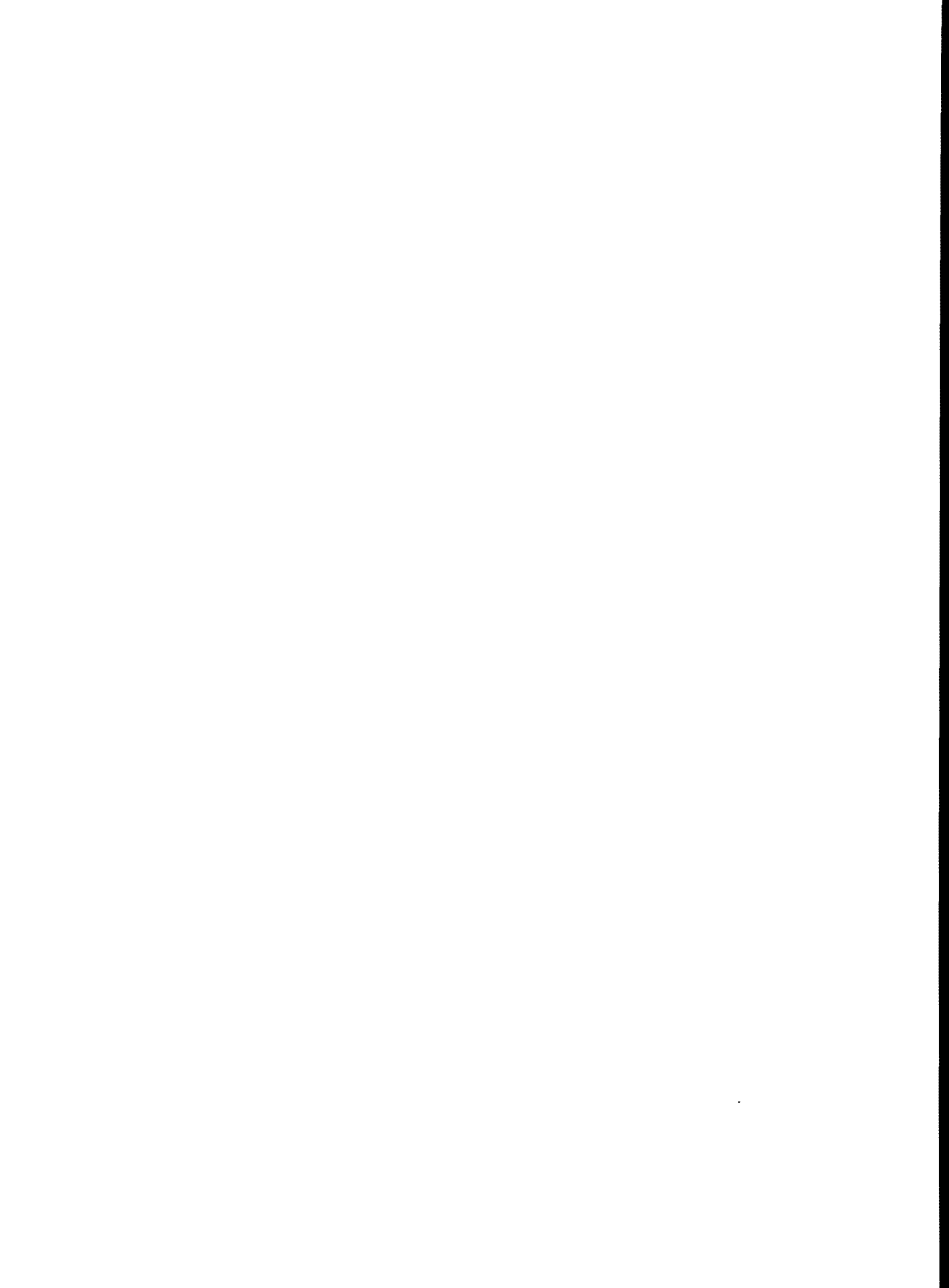



STATUS OF SAFETY SIGNIFICANT

OCPS FOR S/C 011

ITEM	OCPS	Date Transmitted to NASA Safety	Date Sched. for Transmittal to NASA Safety	REMARKS
1.	F0-K-0007 Countdown		7-30	
2.	F0-K-0033 Countdown Demonstration		7-12	7 days for safety review OCP is very similar to S/C 005 0033 except Cryo is used
3.	0034 CSM Altitude Chamber Test		6-2	7 days for safety review
4.	F0-K-0035 Combined Systems Test	5-4		16 days for safety review OCP is very similar to S/C 005 0035 except test is conducted in Alt. Chbr.
5.	F0-K-0038S/C Hypergolic Loading		7-21	7 days for safety review, OCP combines OCP's 4082, 4622, 4624 & 4700 as approved for S/C 009.
6.	F0-K-1090 Water Glycol Servicing System Test, Altitude Chamber, MS0B	4-22		Operation completed
7.	F0-K-1210 Water Glycol Servicing System Test, Cryogenic Test Facility	4-14		Operation completed
8.	F0-K-2016 Forward Compartment Buildup	4-22		Operation completed
9.	F0-K-3045 LES Buildup	4-14		Operation completed
10.	F0-K-3069 C/M, S/M, CSM or SLA Transportation and Handling	4-14		Operation completed

ITEM	OCP	Date Transmitted to NASA Safety	Date Sched. for Transmittal to NASA Safety	REMARKS
11.	F0-K-3071 C/M - S/M Mate	4-14		30 days for safety review
12.	F0-K-3071A C/M - S/M. Mate	5-6		7 days for safety review. This is an "A" revision to the basic which has had the full 30 day review period.
13.	F0-K-3112 LES/BPC to C/M mate/demate and thrust vector alignment verification	4-14		30 days plus for safety review
14.	F0 K-3113 C/M LES weight and balance and thrust vector alignment	March		30 days plus for safety review
15.	F0-K-3116 CSM/SLA Mating	4-14		30 days plus for safety review
16.	F0-K-3117 S/C Transportation to pad and mate	4-22		30 days plus for safety review
17.	F0 K-4058 Electro explosive devices receiving inspection, storage & pre-installation checkout	4-14		Operation completed
18.	F0-K-4065 LBS motor receiving, inspection storage and handling	4-14		Operation completed
19.	F0-K-4066 Pitch Control Motor, Receiving inspection, storage and handling	4-14		Operation completed
20.	F0-K-4067 Jettison Motor Receiving, inspection, storage and handling	4-14		Operation completed
21.	F0-K-4070 C/M RCS functional and Leak Test	April		OCP approved by KSC safety
22.	F0-K-4072 S/M RCS quad leak and functional test	4-22		OCP approved by KSC safety
23.	F0-K-4074 SPS functional and leak test	April		OCP approved by KSC safety
24.	F0-K-4079 SLA ordnance installation and removal	4-14		30 days plus for safety review

ITEM	OCP	Date Transmitted to NASA Safety	Date Sched. for Transmittal to NASA Safety	REMARKS
25.	F0-K-4082 Propulsion pad functional test		7-21	7 days for safety review very similar to OCP 4074 as approved by KSC Safety also used on S/C 009; all specs and drawings have been approved
26.	F0-K-4086 SPS Fuel servicing system test, manual control, LC 34	4-27		16 days for safety review similar to procedure used on S/C 009, all specs. and drawings have been approved.
27.	F0-K-4089 SPS oxidizer servicing system test, manual control, LC 34	5-3		14 days for safety review similar to procedures used on S/C 009, all specs and drawings have been approved.
28.	F0-K-4231-S/A SHMRCs Fuel servicing test, manual control, LC 34		5-13	7 days for safety review, similar to procedure used on S/C 009, all specs and drawings have been approved
29.	F0-K-4237 S/M RCS oxidizer servicing system test, manual control, LC 34		5-18	7 days for safety review, similar to OCP used on S/C 009, all specs and drawings have been approved
30.	F0-K-4243 Helium servicing system test, manual control, LC 34	4-30		10 days for safety review similar to OCP used on S/C 009, all specs. & drawings have been approved.
31.	F0-K-4249 LO <sub>2</sub> servicing system test, manual control, LC 34.		5-23	8 days for safety review, all specs. and drawings have been approved

ITEM	OCP	Date Transmitted to NASA Safety	Date Sched. for Transmittal to NASA Safety	REMARKS
32	FO-K-4252 LH <sub>2</sub> servicing system test, manual control, LC 34		5-31	8 days for safety review, all specs, & drawings have been approved. Operation completed
33	FO-K-4254 fuel servicing system test, propulsion test complex	March		Operation completed
34	FO-K-4601 oxidizer servicing system test, propulsion test complex	March		Operation completed
35	FO-K-4602 pressurization servicing systems test, propulsion test complex	March		Operation completed
36	FO-K-4615 fuel cell and cryo servicing, cryogenic test facility	5-3		OCP approved by KSC Safety
37	FO-K-4616 cryogenic storage system verification, cryogenic test facility	4-29		OCP approved by KSC Safety
38	FO-K-4617 SC ordnance installation and removal		7-8	7 days for safety review, similar to OCP used on S/C 009, specs and drawings have been approved.
39	FO-K-4618 LH <sub>2</sub> servicing system test, manual control, cryogenic test facility	4-14		Operation completed
40	FO-K-4619 L02 servicing system test, manual control, cryogenic test facility	4-14		Operation completed
41	FO-K-4622 SPS tanking/detanking LC 34 section 1 - ACE control section 2 - manual control		7-21	7 days for safety review same as approved for S/C 009 all specs and drawings have been approved.
42	FO-K-4624 C/M RCS tanking/detanking LC 34 section 1 - ACE control section 2 - manual control		7-21	7 days for safety review, same as approved for S/C 009 all specs and drawings have been approved

ITEM	OCP	Date Transmitted to NASA Safety	Date Sched. for Transmittal to NASA Safety	REMARKS
42.	FO-K-4624 C/M RCS tanking/detanking LC 34 section 1 - ACE control section 2 - Manual Control		7-21	7 days for safety review, same as approved for S/C 009, all specs. & drawings have been approved.
43.	FO-K-4700 S/M RCS tanking/detanking LC 34 section 1 - ACE control section 2 - Manual control		7-21	7 days for safety review, same as approved for S/C 009, all specs. & drawings have been approved.
44.	FO-K-4736 fuel cell cryogenic servicing, LC 34		7-12	7 days for safety review, OCP is almost identical to OCP 4615 which is approved by KSC Safety
45.	FO-K-4738 Pyro verification test		5-20	30 days plus for safety review
46.	FO-K-4741 - Fuel cell servicing, LC-34		6-9	7 days for safety review, OCP is almost identical to OCP 4615 which is approved by KSC Safety
47.	FO-K-8227A S/M RCS quantity gaging system calibration	4-22		30 days plus for safety review
48.	FO-K-8236 gas chromatograph analysis system and checkout PLA		5-11	7 days for safety review, complete package; specs., drawings and manual has been approved by KSC Safety
49.	FO-K-9179A LH <sub>2</sub> transfer unit (S14-026)	4-11		OCP approved by KSC Safety
50.	FO-K-9180A LO <sub>2</sub> transfer unit (S14-032)	4-11		OCP approved by KSC Safety
51.	FO-K-9187A LO <sub>2</sub> mobile storage unit (S14-065)	4-11		OCP approved by KSC Safety

ITEM	OCP	Date Transmitted to NASA Safety	Date Sched. for Transmittal to NASA Safety	REMARKS
52.	F0-K-9188B LH <sub>2</sub> mobile storage unit (S14-066)	4-11		OCP approved by KSC Safety
53.	F0-K-9882 ground equipment loading RCS propellant unit (S14-057) hypergolic test facility and launch complexes			Safety review not required for S/C 011 per agreement with KSC Safety; same as OCP approved for S/C 009
54.	F0-K-9883 Ground equipment loading RCS propellant unit (S14-068) hypergolic test facility & launch complexes			Safety review not required for S/C 011 per agreement with KSC Safety; same as OCP approved for S/C 009
55.	F0-K-9885 Loading and unloading SPS propellant unit (S14-059) for propulsion test complex and launch complexes	4-14		30 days plus for safety review
56.	F0-K-9886 loading and unloading SPS propellant unit (S14-058) for propulsion test complex and launch complexes	4-14		30 days plus for safety review
57.	F0-K-10004 SC installations and removals	5-3		8 days for safety review very similar to OCP approved for S/C 009.

April 19, 1967

TO: NASA Headquarters, Code C  
Attention: Richard L. Callaghan

FROM: Counsel, Apollo 204 Review Board

SUBJECT: History of Arcing in Spacecraft 012

On lines 14-16, page 105, Volume 1 of the stenographic transcript of hearings before the House Committee on Science and Astronautics, Subcommittee on NASA Oversight, Congressman Fulton stated,

"I would like to have the previous history of arcing put in the record and what the inferences and responses are from that history, if you please."

Transmitted herewith is the requested History of Arcing, together with the inferences and responses.

George T. Malley

Enclosure

GTMalley:scw 4-19-67

April 19, 1967

Honorable Olin E. Teague  
Chairman, Committee on Science and Astronautics  
Subcommittee on NASA Oversight  
House of Representatives  
Washington, D.C. 20515

Dear Mr. Chairman:

During the course of hearings before your Subcommittee, Congressman Fulton requested that the previous history of arcing in Spacecraft 012 be put in the record and what inferences and responses were made from that history.

The enclosed History of Arcing is therefore submitted for inclusion in the record of the hearings.

Sincerely yours,

Floyd L. Thompson  
Chairman, Apollo 204 Review Board

Enclosure

GTMalley:scw 4-19-67



HISTORY OF ELECTRICAL ARCING  
SPACECRAFT 012 COMMAND MODULE

Five instances of electrical arcing in the command module of spacecraft 012 were observed and recorded on Discrepancy Records.

Three arcing incidents occurred during installation and removal of the pyrotechnic batteries in the command module interior while the spacecraft was at ambient sea level conditions. The first occurred on September 14, 1966 during the installation of a pyrotechnic battery. Discrepancy Record 012-S/C-0176 states that an arc was drawn between the wrench used to install the positive battery lug and the battery mounting screw. The second occurred on September 23, 1966. Discrepancy Record 012-S/C-0248 states that an arc was drawn, while removing a pyrotechnic battery, between the positive terminal of the battery and the disconnected negative battery strap for an adjacent battery. The third occurred on October 9, 1966. Discrepancy Record 012-S/C-0408 states that during installation torquing of a battery positive terminal, an arc was drawn between the wrench handle and the elapsed time meter case corner.

In all three cases, an engineering evaluation of the arcing revealed no damage to the spacecraft. The batteries involved in the three arcing incidents were ground support test batteries, and subsequently were returned to the battery laboratory for check out.

The installation of these batteries is extremely difficult due to the limited access to and the location of the units in the spacecraft. The batteries are ceiling mounted and the two screws used to mount the front portion of the battery must be installed or removed with a tool held at an angle to avoid touching the battery terminals.

The inference drawn from the three arcing incidents during the installation and removal of pyrotechnic batteries in the command module was that the location or the design of the batteries is such that the probability of arcs from the batteries is high when conductive tools are being used to install and remove the batteries.

The response was that Kennedy Space Center reported the battery arcing problem to Manned Spacecraft Center and requested a redesign of the battery to preclude recurrence of arcing. The redesign of the battery is presently under study by the Manned Spacecraft Center.

A fourth arcing incident was discovered during removal of the pyrotechnic panel in the command module interior while the spacecraft was in an ambient sea level condition. This occurred on October 9, 1966. Discrepancy Record 012-S/C-0409 states that an arc was drawn between the top terminal of circuit breaker No. 14 located in the top row of circuit breakers on the panel and the panel mounting nut plate bracket behind the panel. The conformal coating on the circuit breaker had rubbed off during the removal of the panel.

The engineering evaluation of the damage to the circuit breaker and spacecraft was that the damage was not significant. The defect was corrected by replacing the conformal coating. In addition, personnel were cautioned to use extreme caution in installing the panel.

The inference drawn from this arcing incident was that the routing of the wire bundle connecting with the pyrotechnic panel was not properly designed.

The response was that soon thereafter an engineering order was issued which modified the circuitry of the circuit breaker so that the power side of the circuit breaker could not come in contact with the spacecraft structure during panel installation. The change eliminated the possibility of arcing.

The fifth arcing incident occurred while trouble-shooting a malfunction discovered during Operations Checkout Procedure, OCP-K-0005, when removing the C15-1A 52 spacecraft panel. This incident occurred on January 17, 1967 at launch complex 34 at ambient sea level conditions. Discrepancy Record 012-S/C-0917 states that while removing the panel an arc was observed between a screw driver being used to remove the panel and a wire bundle behind the panel. Inspection of the bundle revealed that the insulation was damaged on the wire thus exposing the conductor. The damaged insulation was repaired by wrapping the damaged area with a heat shrinkable insulating material.

The inference drawn was that a wire bundle was routed in front of the panel screws so that it was necessary, after separation of the wire bundle, to insert a screw driver through the wire bundle to reach the screws in order to remove the panel.

The Apollo 204 Review Board recommended to the Apollo Program Office that the design of wire bundle routing be reevaluated.

April 27, 1967

TO: NASA Headquarters, Code C  
Attention: Richard L. Callaghan

FROM: Counsel, Apollo 204 Review Board

SUBJECT: Information concerning organizational responsibility re  
Ground Emergency Provisions (App. D-13) Apollo 204 Review  
Board Report

During the hearings before the NASA Oversight Subcommittee of the House Committee on Science and Astronautics, Congressman Rumsfeld stated (lines 15-17, p. 231, Vol. 1-A Steno. Transcript):

"The Board should submit information as to who was responsible on pages 1311 to D-1313. By whom was it 'not considered' for example?"

The pages referred to are found in the report of Panel 13, Ground Emergency Provisions, at pages D-13-11, D-13-12 and D-13-13 setting forth the Findings and Determinations.

The information furnished to the subcommittee is based on advice received from Manned Spacecraft Center and Kennedy Space Center.

George T. Malley

GTMalley:edm 4-27-67

April 27, 1967

Honorable Olin E. Teague  
Chairman, Committee on Science and Astronautics  
Subcommittee on NASA Oversight  
House of Representatives  
Washington, D. C. 20515

Dear Mr. Chairman:

During the hearings held on April 10, 1967, Congressman Rumsfeld requested the Apollo 204 Review Board to submit information as to who was responsible for the various elements of ground emergency procedures that were stated in the Findings and Determinations on pages D-13-11 to D-13-13 of Appendix D to the Board's Report. Enclosure 1 furnishes the requested information.

The organizational elements having primary and secondary responsibilities are identified after each Finding. The term primary responsibility means documented functional responsibility for the efforts involved in either the generation, review or approval of the subject matter treated in the Finding. The term secondary responsibility means an operational or developmental participation which, as a normal function, would require an awareness or surveillance of the subject matter treated in the Finding.

At Manned Spacecraft Center the organizational responsibilities have been defined to the directorate level within the Manned Spacecraft Center. The responsibilities fall into three groups:

1. Generation of procedures
2. Review or approval of procedures or design
3. Design of spacecraft or ground systems

Manned Spacecraft Center, as an organization, had the responsibility for one or more of the three groups only in Findings 1-5 and 7.

At Kennedy Space Center, the organizational responsibilities have been defined to an Office or Division level. The detailed delineation of areas of responsibility at KSC, it is understood, will be furnished by the Associate Administrator, OMSF. Therefore, to avoid unnecessary duplication, the Offices and Divisions have only been identified as having either primary or secondary responsibility.

At North American Aviation Florida Facility, the organizational responsibilities have been defined to the Department or Office level.

Sincerely yours,

Floyd L. Thompson  
Chairman, Apollo 204 Review Board

Enclosure

GTMalley:edm 4-27-67

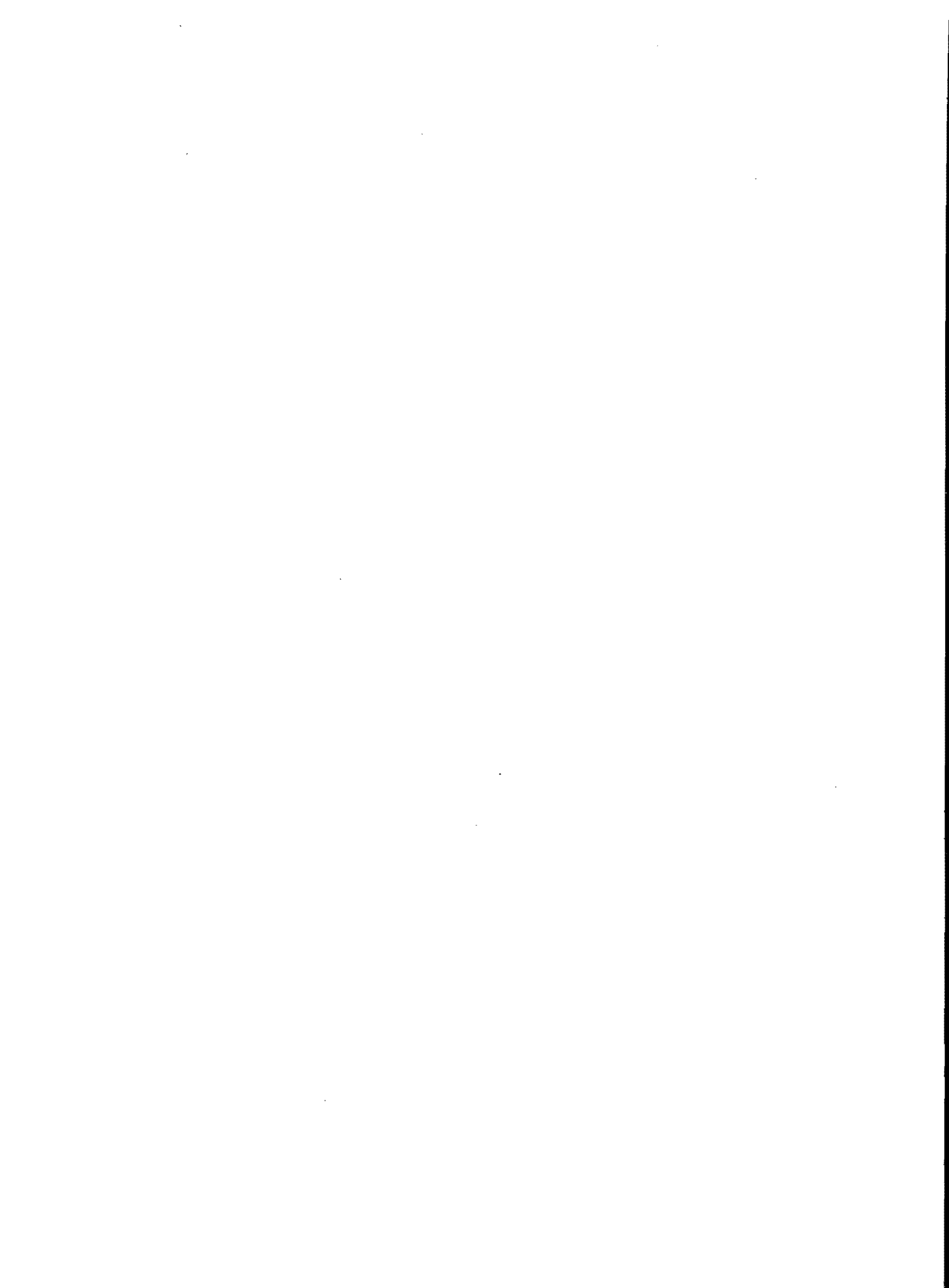

ENCLOSURE 1

FINDING NO. 1

The applicable test documents and flight crew procedures for the AS-204 Space Vehicle Plugs Out Integrated Test did not include safety considerations, emergency procedures, or emergency equipment requirements relative to the possibility of an internal spacecraft fire during the operation.

MANNED SPACECRAFT CENTER

- |                                       |        |
|---------------------------------------|--------|
| 1. Apollo Spacecraft Program Office   | Review |
| 2. Flight Crew Operations Directorate | Review |

KENNEDY SPACE CENTER

Primary Responsibility:

1. The Safety Office of the Directorate of Installation Support (DIS)
2. The Flight Systems Division of the Directorate of Spacecraft Operations (SCO)

Secondary Responsibility:

1. Test and Operations Office of the Directorate of Launch Operations (DLO)
2. SCO Test and Management Office

NORTH AMERICAN AVIATION FLORIDA FACILITY (NAAFF)

Primary Responsibility:

1. NAAFF Command and Service Module (CSM) Safety Office
2. NAAFF Spacecraft Engineering Department

Secondary Responsibility:

NAAFF Spacecraft Operations Department

FINDING NO. 2

There are no documented safety instructions or emergency procedures in existence which are applicable to the possibility of a serious internal spacecraft fire.

MANNED SPACECRAFT CENTER

- |                                       |  |
|---------------------------------------|--|
| 1. Flight Crew Operations Directorate | Generation (flight crew procedures only) |
| 2. Apollo Spacecraft Program Office   | Review/approval                          |

KENNEDY SPACE CENTER

Primary Responsibility:

1. DIS Safety Office
2. SCO Flight Systems Division

Secondary Responsibility:

1. DLO Test Operations Office
2. SCO Test and Management Office

NORTH AMERICAN AVIATION FLORIDA FACILITY

Primary Responsibility:

1. NAAFF Apollo CSM Safety Office
2. NAAFF Engineering Office

Secondary Responsibility:

NAAFF Operations Office

FINDING NO. 3

The propagation rate of the fire involved in the AS-204 accident was extremely rapid (reference report by Panel 5). Removal of the three spacecraft hatches to effect emergency egress from either the inside or outside involved a minimum of 40 and 70 seconds, respectively, under ideal conditions.

MANNED SPACECRAFT CENTER

- |  |   |
|--|---|
| 1. Apollo Spacecraft Program Office        | Determined the acceptability of the spacecraft hatch design |
| 2. Engineering and Development Directorate | Determined the acceptability of the spacecraft hatch design |



- |                                       |  |
|---------------------------------------|--|
| 3. Flight Crew Operations Directorate | Determined the accept-ability of the spacecraft hatch design |
| 4. Flight Operations Directorate      | Determined the accept-ability of the spacecraft hatch design |

KENNEDY SPACE CENTER

None

FINDING NO. 4

Procedures for unaided egress from the spacecraft were documented and available. The AS-204 flight crew had participated in a total of eight egress exercises employing those procedures.

MANNED SPACECRAFT CENTER

- |                                       |            |
|---------------------------------------|------------|
| 1. Flight Crew Operations Directorate | Generation |
| 2. Flight Operations Directorate      | Approval   |

KENNEDY SPACE CENTER

Primary Responsibility:

The Emergency Egress Working Group (EEWG) of the Apollo Launch Operations Committee (ALOC).

The EEWG is comprised of appropriate disciplines from NASA, AFETR, and NAAFF personnel. Chairman of both the EEWG and the ALOC is the Director of Launch Operations, KSC.

FINDING NO. 5

The Apollo Flight Crew Hazardous Egress Procedures Manual contains procedures relative to unaided, aided, and incapacitated flight crew egress. By scope and definition, this document is concerned only with evacuation of the flight crew from the spacecraft and the pad under hazardous conditions occurring primarily external to the spacecraft during a launch operation.

MANNED SPACECRAFT CENTER

- |                                    |            |
|------------------------------------|------------|
| Flight Crew Operations Directorate | Generation |
|------------------------------------|------------|

KENNEDY SPACE CENTER

Primary Responsibility:

Same as for Finding No. 4.

FINDING NO. 6

The spacecraft pad work team on duty at the time of the accident had not been given emergency training drills for combating fires in or around the spacecraft or for emergency crew egress. They were trained and equipped only for a normal hatch removal operation.

MANNED SPACECRAFT CENTER

None

KENNEDY SPACE CENTER

Primary Responsibility:

1. DIS Safety Office
2. DLO Test Operations Office
3. SCO Test and Management Office

NORTH AMERICAN AVIATION FLORIDA FACILITY

Primary Responsibility:

1. Apollo CSM Safety Office
2. Spacecraft Operations Department
3. Technician Support Department

FINDING NO. 7

There was no equipment on board the spacecraft designed to detect or extinguish a cabin fire.

MANNED SPACECRAFT CENTER

- |  |  |
|--|--|
| 1. Engineering and Development Directorate | Determined the acceptability of the design |
| 2. Flight Crew Operations Directorate      | Determined the acceptability of the design |

- |                                     |  |
|-------------------------------------|--|
| 3. Flight Operations Directorate    | Determined the acceptability of the design |
| 4. Apollo Spacecraft Program Office | Determined the acceptability of the design |

KENNEDY SPACE CENTER

None

FINDING NO. 8

Frequent interruptions and failures had been experienced in the overall communications system during the operations preceding the accident. At the time the accident occurred, the status of the system was still under assessment.

MANNED SPACECRAFT CENTER

Apollo Program Office

Review

KENNEDY SPACE CENTER

Primary Responsibility:

1. DIS Safety Office
2. DLO Test Operations Office
3. SCO Test and Management Office

NORTH AMERICAN AVIATION FLORIDA FACILITY

Primary Responsibility:

1. Apollo CSM Safety Office
2. Operations Office

NORTH AMERICAN AVIATION DOWNEY

Spacecraft Design Engineering

AIR FORCE EASTERN TEST RANGE

Range Safety Division

FINDING NO. 9

Emergency equipment provided at the spacecraft work levels consisted of portable CO<sub>2</sub> fire extinguishers, Rocket Propellant Fuel Handler's Gas Masks, and 1-1/4 inch diameter fire hoses.

MANNED SPACECRAFT CENTER

None

KENNEDY SPACE CENTER

Primary Responsibility:

1. Safety Office of the Directorate of Installation Support (DIS)
2. Test and Operations Office of the Directorate of Launch Operations (DLO)
3. Test and Management Office of the Directorate of Spacecraft Operations (SCO)

NORTH AMERICAN AVIATION FLORIDA FACILITY

1. Apollo CSM Safety Office
2. Operations Office

AIR FORCE EASTERN TEST RANGE

Range Safety Division

FINDING NO. 10

There are steps and doorways on the Launch Complex 34 Apollo Access Arm and in the environmental enclosure (White Room) which constitute safety hazards, particularly under emergency conditions.

MANNED SPACECRAFT CENTER

Apollo Program Office

Review

KENNEDY SPACE CENTER

Primary Responsibility:

1. Emergency Egress Working Group
2. DIS Safety Office
3. DLO Test Operations Office
4. SCO Test and Management Office

NORTH AMERICAN AVIATION FLORIDA FACILITY

1. Apollo CSM Safety Office
2. Operations Office

AIR FORCE EASTERN TEST RANGE

Range Safety Division

FINDING NO. 11

During the preparation of S/C test procedures at KSC, safety considerations for hazardous operations and documentation of applicable emergency procedures are limited in most cases to routine safety reference notations and emergency power-down instructions.

MANNED SPACECRAFT CENTER

None

KENNEDY SPACE CENTER

Primary Responsibility:

1. DIS Safety Office
2. SCO Test and Management Office

NORTH AMERICAN AVIATION FLORIDA FACILITY

1. Spacecraft Engineering and Operations Departments
2. Apollo CSM Safety Office

FINDING NO. 12

Under the existing method of test procedure processing at KSC, the cognizant Safety Offices review only those procedures which are noted in the OCP outline as involving hazards. Official approval by KSC and AFETR Safety is accomplished after the procedure is published and released.

MANNED SPACECRAFT CENTER

None

KENNEDY SPACE CENTER

Primary Responsibility:

DIS Safety Office

FINDING NO. 13

Criteria for defining hazardous test operations are not complete.

MANNED SPACECRAFT CENTER

None

KENNEDY SPACE CENTER

Primary Responsibility:

1. DIS Safety Office
2. Directorate of Spacecraft Operations

NORTH AMERICAN AVIATION FLORIDA FACILITY

Spacecraft Management Office

FINDING NO. 14

Requirements for the review and concurrence of KSC S/C test procedures by MSC are not well defined.

MANNED SPACECRAFT CENTER

Apollo Program Office

KENNEDY SPACE CENTER

Primary Responsibility:

Apollo Program Office

SECTION 3

FINAL REPORT OF PANEL 18

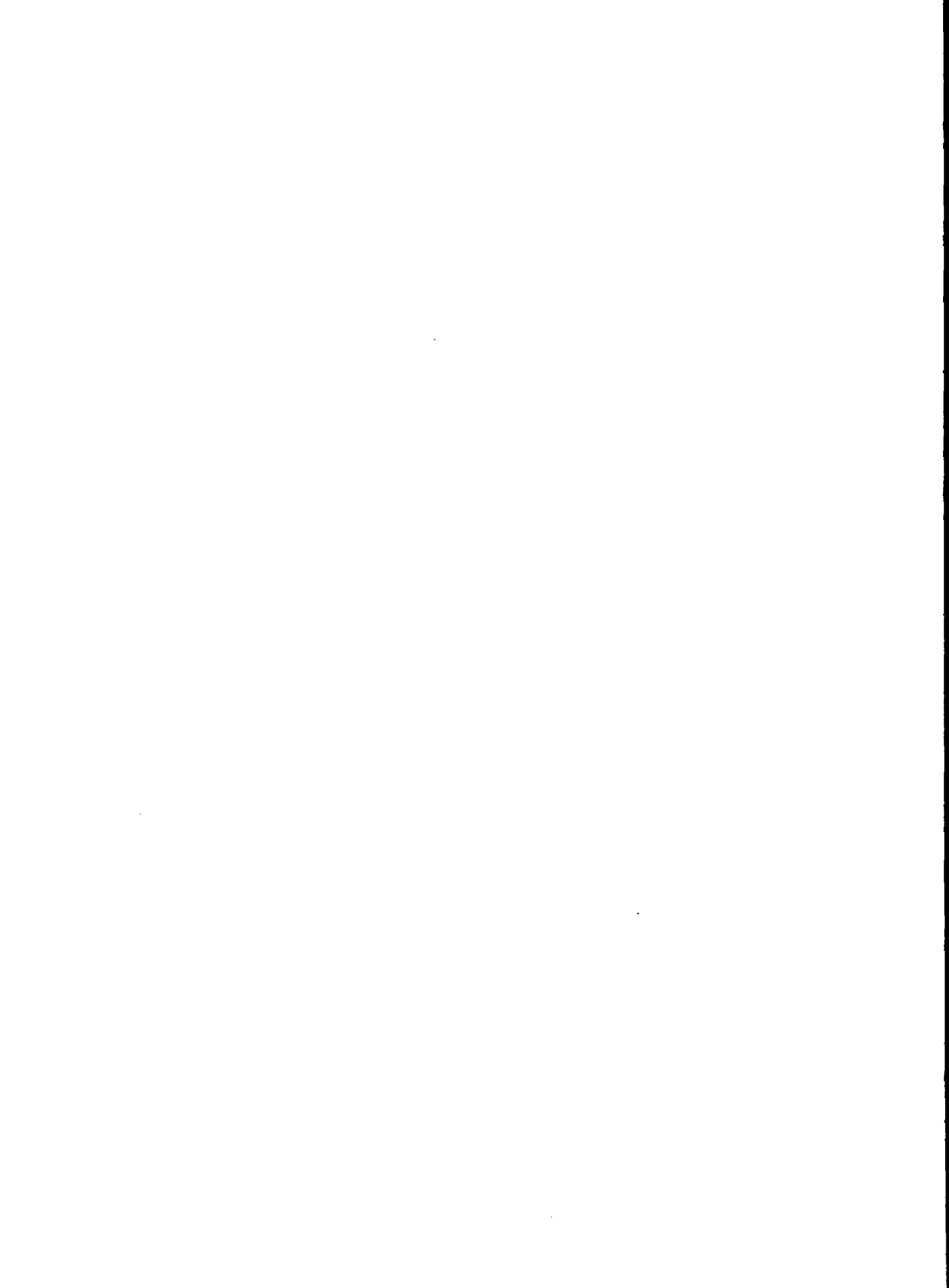



X

MANNED SPACECRAFT CENTER  
ATTENTION: DR. MAXIME A. FAGET

MANNED SPACECRAFT CENTER  
ATTENTION: COLONEL FRANK BORMAN

NASA HEADQUARTERS  
ATTENTION: MR. GEORGE C. WHITE, CODE MAR  
WASHINGTON, D. C.

IN MY CAPACITY AS CHAIRMAN OF THE APOLLO 204 REVIEW BOARD, I AM  
HEREBY APPOINTING A SUBCOMMITTEE TO EXAMINE THE FINAL REPORT OF  
PANEL 18 AND PREPARE RECOMMENDATIONS REGARDING ITS ACCEPTABILITY  
FOR INCLUSION IN APPENDIX G OF THE BOARD'S REPORT.

THE FOLLOWING MEMBERS OF THE APOLLO 204 REVIEW BOARD ARE APPOINTED  
TO MEMBERSHIP ON THIS SUBCOMMITTEE:

DR. MAXIME A FAGET, CHAIRMAN

COLONEL FRANK BORMAN

MR. GEORGE C. WHITE

MR. E. BARTON GEER

IT IS REQUESTED THAT THIS SUBCOMMITTEE MEET AND FORWARD TO ME  
AT THE EARLIEST POSSIBLE DATE ITS RECOMMENDATIONS REGARDING THE  
PANEL 18 REPORT. IT IS FURTHER REQUESTED THAT THIS SUBCOMMITTEE  
REVIEW COMMENTS OF THE NORTH AMERICAN AVIATION CORPORATION  
RELATIVE TO THE VALIDITY OF THE FINDINGS OF THE REPORT OF THE

X

BOARD AND ITS PANELS, AND IN SO DOING, DETERMINE THE VALIDITY OF ANY CLAIMS OF ERRONEOUS FINDINGS.

IT IS REQUESTED THAT THIS SUBCOMMITTEE MEET AT THE MANNED SPACECRAFT CENTER, HOUSTON, TUESDAY, MAY 16, 1967, OR AS SOON THEREAFTER AS POSSIBLE FOR THE PURPOSE OF CARRYING OUT THIS ASSIGNMENT.

SIGNED FLOYD L. THOMPSON  
CHAIRMAN, APOLLO 204 REVIEW BOARD

FLOYD L. THOMPSON, DIRECTOR

4761

2 2  
MAY 12, 1967 - 3:30 P.M.



NATIONAL AERONAUTICS AND SPACE ADMINISTRATION  
MANNED SPACECRAFT CENTER  
HOUSTON, TEXAS 77058

MAY 16 1967

IN REPLY REFER TO: EA

TO: Chairman, Apollo 204 Review Board  
FROM: Chairman, Special Subcommittee

The subcommittee appointed by you to examine the panel 18 draft for Appendix G of the Apollo 204 Review Board Report met on May 16, 1967. This draft was edited as to technical content and is being forwarded to Mr. Jesse Ross for publication.

The content of this report does not modify the validity of the narrative or findings of the 204 Review Board Report and its appendices. It does provide one significant piece of information concerning the circumstances of the accident. A complete analysis of data relative to the operation of the ECS throughout the "plug-out" tests indicates that there is substantial evidence of a small leakage of water/glycol during the test period. The location of this leak cannot be determined from data indications alone. Other considerations lead to the conjecture that this leak may have occurred within the Command Module.

Since all planned analysis and investigations relative to the purpose of the Apollo 204 Review Board are now complete, it is recommended that the S/C 012 be placed within its storage container and shipped to LRC. It is likewise recommended that all other material now being held by the board, such as S/C 014, be released to the Apollo Spacecraft Program Office.

  
Maxime A. Faget

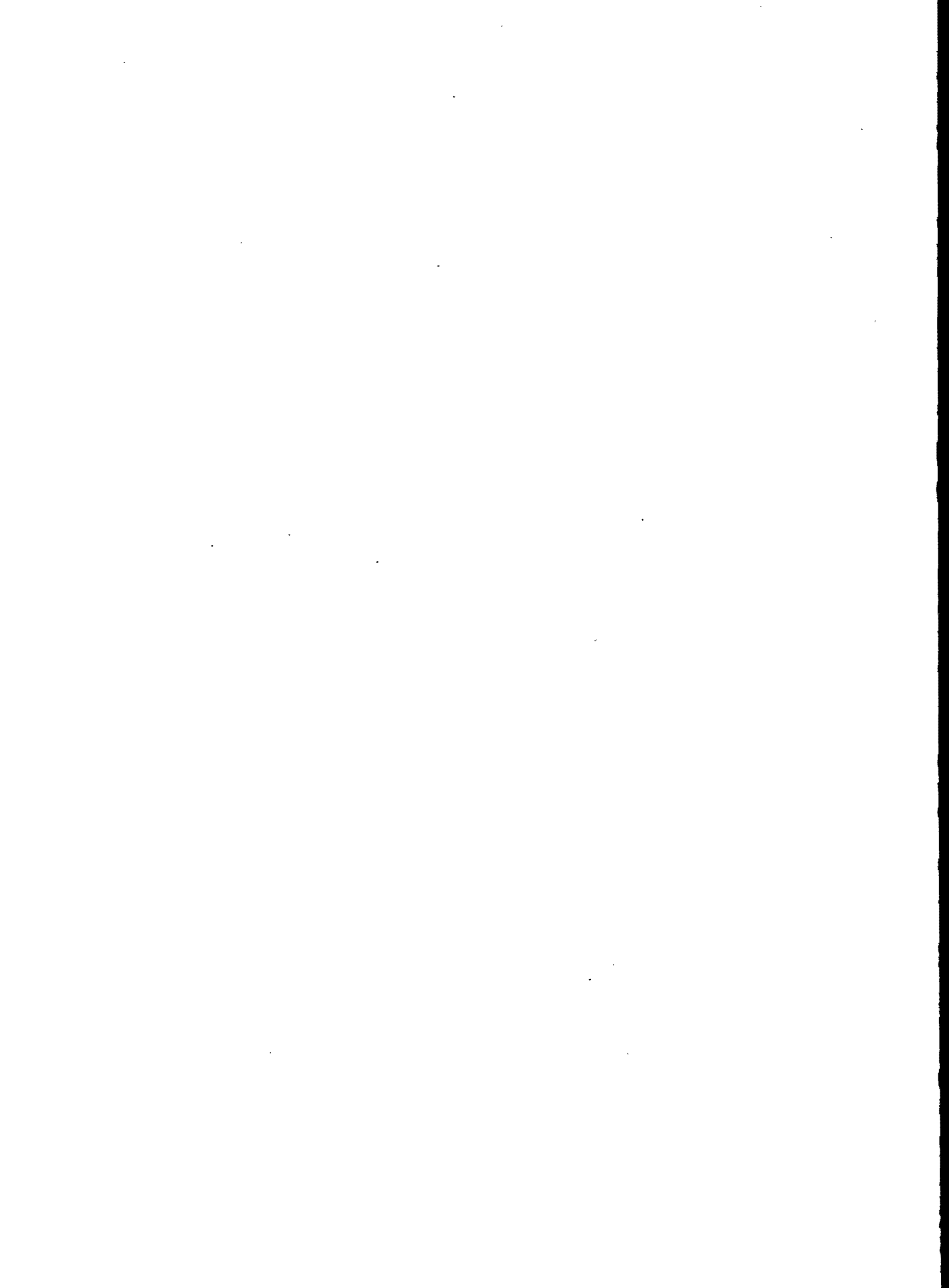

SUPPLEMENTARY  
REPORT OF PANEL 18  
INTEGRATION ANALYSIS PANEL  
APPENDIX G  
TO  
FINAL REPORT OF  
APOLLO 204 REVIEW BOARD



At the time of submission of the Panel 18 Final Report, a number of work activities were incomplete. These are summarized below and are listed in more detail in Enclosure G-1.

1. Open Circuit Breaker Analysis
2. Open Fuses Analysis
3. Electrical System Continuity Checks
4. Command Pilot Boots Examination
5. Cabin Air Fan 1 Wiring Examination
6. Octopus Cable Examination
7. Water/Glycol Data Analysis
8. Lithium Hydroxide Access Door Examination
9. Completion of "Board Action Summary"
10. Gas Chromatograph Data Interpretation
11. Water/Glycol Tests
12. Boilerplate Fire Test Analysis
13. Crushed DC Instrumentation Harness Examination
14. Analysis of Voice Tapes
15. Torque Motor Voltage Transient Analysis

The above activities have been completed. The completion did not disclose any new suspect areas which may have caused the accident. The results of these activities are summarized in this report.

In addition, two other activities which have been omitted from the above listing have been completed. These are:

16. ECS Cable Assemblies Examination
17. Completion of "Summary of Special Tests"

All Panel 18 activities are concluded with the submission of this report.

#### 1. Open Circuit Breaker Analysis

Enclosure 18-4 of Appendix D listed 33 circuit breakers that were to be closed but were found open after the accident. The causes of the open circuit breakers were not known at the time of issuance of the Board Report. It was thought that a determination as to when or why each circuit breaker opened may disclose additional suspicious wiring areas.

The Analysis has been completed. No new suspicious wiring areas resulted from this analysis. A complete list of the open circuit breakers and the associated analysis is attached as Enclosure G-2.

## 2. Open Fuses Analysis

At the time of issuance of the Board Report, the identity of all blown fuses was not established. It was thought that an analysis of when and why each fuse opened may disclose additional suspicious wiring areas.

The analysis has been completed. Fourteen fuses were found open. No new suspicious wiring areas resulted from this analysis. A complete list of the fourteen open fuses and the associated analysis is attached as Enclosure G-3.

## 3. Electrical System Continuity Checks

At the time of issuance of the Board Report, additional continuity checks were required to establish that certain suspect wiring was installed as required by manufacturing drawings.

The checks have been completed. All suspect wiring was installed as required by manufacturing drawings. Specifically, the following wiring was checked, (all other suspect wiring was checked previously):

- (a) Arc between a DC Wire and the Cover of J-Box C15-1A52: The wire was established to be tied into the DC bus A circuit.
- (b) Shorted Gas Chromatograph AC Wiring: The wiring was established to be tied into the AC bus 1 phase A circuit.

## 4. Command Pilot Boots Examination

An examination of the Command Pilot's boots was required in the Metallurgical Laboratory at KSC to check the condition of the Velcro pad screws for signs of arcing.

The examination has been completed. No arcing phenomena was observed on any of the screws. A summary of the examination follows:

The boot soles were severely charred and covered with soot. The Velcro was burned off the bottoms of the soles. The upper portions of the boots were missing. Particles of material, exhibiting a molten appearance, were present on the left boot sole. Samples of this material were removed for a chemical analysis. Infrared analysis revealed that



the material was molten nylon. The screw heads were photographed, cleaned with ethyl alcohol and examined microscopically. No signs of arcing were observed on any of the six screws.

#### 5. Cabin Air Fan 1 Wiring Examination

An examination of cabin air fan 1 AC wiring was required in the Metallurgical Laboratory at KSC to establish with complete certainty that shorting was an effect of the fire.

The examination has been completed. A summary of the examination follows:

An abraded region on one of four wires probably resulted from contact during removal of the cabin fan. Melted material found among the inner strands of another wire was solder, which flowed along the wire after heating of the connector during the fire. Thermal degradation of the wire strands was restricted to grain growth. No melting was found. It is concluded that shorting was a consequence of the fire, in which the insulation of the cabin fan wiring was destroyed in two regions.

#### 6. Octopus Cable Examination

An examination of the octopus cable was required in the Metallurgical Laboratory at KSC to establish with complete certainty that shorting was an effect of the fire.

The examination has been completed. It is concluded that shorting was a consequence of the fire, in which the twisted unshielded wires were exposed in places due to insulation melting.

#### 7. Water/Glycol Data Analysis

The data from the water/glycol cooling system has been analyzed for the time period from 20:30:00 to 23:30:00 GMT. This analysis disclosed the possibility of a small leak in the system (spacecraft and ground loop) in the order of 50cc during this time period.

Enclosure G-4 depicts the results of the analysis of the water/glycol volume change over the 3-hour period. The curves presented in this enclosure are the measured volume change, the calculated increments due to temperature and pressure effects, and the volume change which cannot be accounted for by the analysis, other than leakage. The derivation of water/glycol volume change data is somewhat complex and in-

volves a multiplicity of parameters of varying degrees of accuracy. Because of this and possibly some unknown system variable, it is difficult to establish a degree of high confidence in the water/glycol volume change data.

The water/glycol loop includes the spacecraft and GSE as one closed loop system. From all of the data available it cannot be concluded whether the indicated leakage was internal or external to the spacecraft.

#### 8. Lithium Hydroxide Access Door Examination

An examination of the bottom of the lithium hydroxide access door was required in the Metallurgical Laboratory at KSC to check for signs of arcing and traces of copper. This examination was required as an earlier visual inspection reported indications of copper on the bottom of the access door. (Reference page D-18-37 of Appendix D).

The examination has been completed. No evidence of arcing along the bottom of the door was revealed. There was no evidence of extraneous copper or nickel in the suspect area.

#### 9. Completion of "Board Action Summary"

All Spacecraft 012 hardware inspection, disassembly, test and analysis requirements were approved by the Board. The status of the implementation of these requirements was reported by means of a "Board Action Summary." Approximately 7 of 182 items report were incomplete at the time of the publication of the final report.

The physical work for all Board Action Items has been completed. The completion of this activity did not disclose any new suspect causes of ignition.

The paper work for two Board Action Items is being completed at this time:

Action 168 - Phase II ECS Test and Disassembly Plan  
(All work subsequent to Phase II comes under the purview of the Program Office).

Action 180 - Open TPS Technique to get work done after Board left KSC.

All TPS Summary paper for Action 168 will be signed off by May 19, 1967. All TPS paper for Action 180 will be signed

off when Spacecraft 012 leaves KSC. No Board or Panel activity is required to complete the paper sign-off. Following completion of these actions, the associated records will be forwarded to the Apollo 204 Review Board files.

A final "Board Action Summary" was published on May 11, 1967. (Reference G-1).

#### 10. Gas Chromatograph Data Interpretation

In Appendix D, it was stated that the gas chromatograph measurement output varied seven times in the 22:00 to 23:00 GMT time period. It then remained totally quiescent for approximately 35 minutes and at 23:30:50 GMT, approximately 14 seconds prior to the crew report of fire, it again produced an output.

Referring to Enclosure 18-7 of Appendix D, the level shifts shown in traces A, B, C, D, and E were bias shifts caused by cross-talk from adjacent telemetry channels. Tests have been demonstrated that this is normal and can be expected whenever a telemetry channel is not terminated in a signal source impedance of 5,000 ohms or less. The movements shown on traces F and G are most probably caused by crew movement. Trace H is considered to have a special meaning with respect to the accident because the trace was quiet for so long a period and an output then occurred approximately 14 seconds prior to the report of the fire.

Tests were conducted at MSC to determine what physical phenomena can cause an output on the gas chromatograph measurement. Enclosure G-6 shows the outputs of some of these tests as compared to the S/C 012 output (Trace A).

Trace B is from a S/C 008 test and shows the output which resulted from handling the gas chromatograph cable and connector. The output magnitude and polarities are similar to the S/C 012 output.

Trace C is from a S/C 008 test and shows the output resulting from striking a high current DC arc near the gas chromatograph cable. These tests revealed that short circuit currents required to duplicate the magnitude of the S/C 012 gas chromatograph output are much higher than the launch complex power supply can provide, inferring that the S/C 012 output was not caused by a DC short or arc alone.

Traces D and E are from laboratory tests with a PCM system and show the outputs resulting from locally heating the gas

chromatograph signal wire with a butane torch. The polarities and magnitudes of these outputs are similar to the S/C 012 output.

Trace F is from a laboratory test with a telemetry system and shows the output resulting from moving a one square foot grounded aluminum plate between one to twelve inches from the gas chromatograph signal wire. The output is the result of capacitive coupling between the plate and the signal wire. Certain body movements in proximity to the signal wire will produce similar capacitive effects. Output magnitudes and polarities similar to the S/C 012 output can readily be duplicated in this manner.

Laboratory tests were run on May 16 and 17 where water/glycol was dripped and sprayed on gas chromatograph wires. Both conditions produced outputs similar in magnitude and polarity to the output seen in S/C 012.

The conclusion which can be drawn from these special tests is that the S/C 012 output could have been caused by one of the following:

- (a) Crew movement near the gas chromatograph cable, or physical movement and disturbance of the gas chromatograph cable.
- (b) Application of external heat or flame to the gas chromatograph cable.
- (c) Dripping or spraying water/glycol on the gas chromatograph cable.

## 11. Water/Glycol Tests

### A. Water/glycol effects on connectors

Two tests utilizing five cable/connector assemblies were conducted at KSC in the Materials Analysis Laboratory. The purpose of these tests was to determine the effect of water/glycol on connectors. The first test consisted of briefly immersing mated connectors in water/glycol, cleaning by normal procedure, and then applying normal spacecraft electrical power through them while in a 100% oxygen atmosphere. The second test consisted of applying electrical power through the connectors while immersed in water/glycol at normal ambient atmosphere.

No evidence of electrical breakdown or degradation was noted in the cable/connector assemblies from either of the tests. Crystalline growth was barely detectable on the connector pins after 20 days immersion or vapor exposure

#### B. Water/glycol flammability

Four separate tests were conducted at KSC in the Materials Analysis Laboratory. The purpose of those tests was to determine the ignitability and flame propagation on water/glycol treated Teflon wire bundles and an aluminum plate. All tests were conducted in a 14.7 psia oxygen atmosphere. Three tests utilized 18 inch, 9 strand Teflon insulated wire bundles with a piece of Velcro attached to one end of the bundles which served as an ignition point. A piece of paper was attached to the other end of the bundles to act as a "flag" for flame propagation. The fourth test utilized a 3" x 3" x 1/8" aluminum plate wetted with water/glycol.

In the first test the wire bundle was immersed in water/glycol for ten minutes, then evacuated for 22 hours at approximately 4,000 microns pressure in a test chamber. The test chamber was then filled with oxygen and the Velcro patch ignited by a nichrome wire. The second test utilized a water/glycol solution from which essentially all the water had been evaporated. The wire bundle was soaked with this solution then placed in the test chamber without additional evacuation and the chamber filled with oxygen. The Velcro tipped-end of the bundle was ignited as in the first test. The third test was a repeat of the first test, except that the 22 hour evacuation was approximately 25 microns pressure. The fourth test was conducted by placing 50 drops of water/glycol on an aluminum plate and igniting with a paper cylinder.

On the three wire bundle tests, the Velcro patch burned to completion and slight charring of the Teflon insulation occurred in the immediate vicinity of the Velcro. No further flame propagation appeared after the Velcro completed burning, and the paper "flag" did not ignite. The fourth test resulted in ignition and burning of the water/glycol. The aluminum plate did not burn.

#### 12. Boilerplate Fire Test Analysis

Command Module Mockup Test 6B was conducted at MSC on April 4, 1967. This was planned as the closest simulation to the Spacecraft 012 accident. Material selection and the layout of the most probable zone of fire initiation were duplicated. Pro-

vision was also made for simulation of the oxygen and water/glycol lines rupture in the mockup test article.

The atmosphere at initiation of the test was 94% oxygen and 6% nitrogen at a total pressure of 16.6 psia. The fire was initiated in the debris netting traversing the floor on the left side of the Command Module at the point where the DC wiring for ECS instrumentation laid over the Waste Management System stainless steel line.

The following observations were made:

- (a) The elapsed time from actual ignition to simulated rupture was 33.3 seconds.
- (b) The first vertical propagation of fire occurred between 16 and 17 seconds after ignition on Velcro strips in the lower left-hand corner of the Command Module by the water panel.
- (c) The first flame above the Command Pilot's couch became visible between 17 and 18 seconds after ignition.
- (d) Ignition of Uralane foam in the heat exchanger panel occurred between 20 and 21 seconds after ignition.

The elapsed time between the first flame above the couch and simulated cabin rupture was 15.8 seconds. This is in close agreement with the Spacecraft 012 data where the elapsed time between the crew report of fire and cabin rupture was 14.7 seconds. The elapsed time between ignition and first flame above the couch was 17.5 seconds in the simulation. Assuming that ignition occurred at the time of the electrical abnormality on Spacecraft 012, the elapsed time to the crew report of fire was 9.8 seconds. The difference in elapsed times is almost a factor of two.

It is believed that the above variation in elapsed times is caused by different burning rates of debris netting. The percentage oxygen content was higher in Spacecraft 012 than in the test article. Special tests at KSC disclosed that the horizontal burning rates differ with oxygen content as follows:

90% oxygen at 14 psia = 1.1 inch/second rate  
100% oxygen at 14 psia = 2.1 inch/second rate

### 13. Crushed DC Instrumentation Harness Examination

An examination of a crushed wire harness for ECU instrumentation was required in the Metallurgical Laboratory at KSC to positively establish that no wires were shorted or damaged.

This cable consisted of two three-conductor and two two-conductor shielded sub-cables with an overall shielded cover. The outer copper braid and the inner braids and insulation, as exposed when the ends were stripped, appeared uninjured. Electrical continuity was established for each conductor.

### 14. Analysis of Voice Tapes

Analysis of voice tapes during the period of the fire has been concluded at MSC. The areas of additional concentration were noise and open face plate evaluation.

The noises were movement, breath, and noises not associated with any identifiable action. Even with extensive testing, simulation, analysis, etc., the probability of ever identifying the sources of the noises or the activity associated with them is considered very low. No further work will be undertaken.

In Appendix D it was stated that there was evidence of an open face plate in the time period 23:30:14 to 23:31:00 GMT. Further analysis of the data indicates no prominent energy in the ECS frequency range. The suit compressor whine was distinctive during an early open face plate time but was lacking during this time interval. It has therefore been concluded that the Command Pilot's face plate was not open immediately prior to the crew report of fire.

The details of this analysis are contained in Reference G-2.

### 15. Torque Motor Voltage Transient Analysis

The Spacecraft 012 Guidance and Navigation System Inertial Measurement Unit (IMU) outer gimbal (OG) and middle gimbal (MG) torque motor voltage measurements indicated a transient when the electrical anomaly occurred. The inner gimbal (IG) measurement did not indicate this transient. The transient was coincident with the transient on the AC bus 2 voltages at 23:30:54.85 GMT.

Test were conducted using Spacecraft 008 and a Guidance and Navigation System at MSC to try to duplicate the OG and MG torque motor voltage transients. These tests disclosed that the inverter could not cause the transients. The DC bus voltages were then adjusted so that bus B was higher than bus A, as was the case in Spacecraft 012. When DC bus B was then either opened or shorted momentarily, a transient appeared on the OG and MG torque motor voltage measurements.

The IMU gimbal servo loop schematics were examined to determine how the transient was coupled to the OG and MG torque motor voltages but not to the IG torque motor voltage. Enclosure G-7 is a schematic diagram of the gimbal servo amplifier.

Point A, on the right side of Enclosure G-7, receives unregulated power from both DC busses A and B. This power is supplied through diodes from each bus to prevent a short on one bus from drawing current from the other bus and to allow uninterrupted IMU operations in the event that one bus is disabled. An unregulated DC to DC converter takes power from the same source and supplies minus 27.5 volts DC to point B. This power supply is unregulated so that long term drifts in the DC bus voltages will not upset the bias condition in the servo amplifiers.

Point C is the first point in the signal path (going from left to right) where the DC supply voltages are not Zener diode regulated. A DC power transient will be introduced into the signal path at this point and will be amplified by subsequent stages. The same magnitude signal will be introduced into all three servo loops (IG, MG, and OG). The IG servo loop voltage gain is about one-tenth as large as that of the OG loop and one-fifth as large as the MG loop. Because of the small IG servo loop voltage gain compared to the MG and OG voltage gain, the transient such as that which occurred during the Spacecraft 012 test would not be seen in the IG servo loop voltage.

It is concluded that the torque motor voltage transients at 23:30:55 GMT were the expected result of a DC open or shorted condition.

#### 16. ECS Cable Assemblies Examination

An examination of two ECS cable assemblies providing DC power to an instrumentation temperature sensor power



supply was required in the Metallurgical Laboratory at KSC to check for conditions of arcing or shorting.

Electrical cable assembly P/N 836599-1-1: The insulation appeared to have been destroyed over much of the cable length. When the braid was cut away from a badly degraded region, no evidence of severe thermal degradation of wires (arcing or melting) was observed. This cable assembly is therefore no longer considered a suspect source of ignition.

Electrical cable assembly P/N 836602-1-1: Part of this cable assembly has been burned and was missing. The ends appear to have been melted by flame impingement. This cable assembly is still considered a suspect source of ignition.

#### 17. Completion of "Summary of Special Tests"

At the time of issuance of the Board Report, only a brief summary of significant special test results was attached as Enclosure 18-56 of Appendix D. Since that time, all but one of the special tests have been completed.

All special test results are summarized in a report "Summary of Special Tests" dated May 12, 1967 (Reference G-3).

The one special test incomplete at this time is a lithium hydroxide cartridge test being conducted at the request of Panel 11. This test is not related to the cause of the accident. Upon completion the results will be deposited in the Apollo 204 Review Board files as part of the Panel 11 activities.

#### List of Enclosures:

<u>Enclosure</u>	<u>Description</u>
G-1	Memorandum "Open work at the time of submission of Panel 18 Final Report," dated April 5, 1967
G-2	Open Circuit Breaker Analysis
G-3	Open Fuses Analysis
G-4	Water/Glycol Quantity Data
G-5	
G-6	Gas Chromatograph Trace Comparison
G-7	Gimbal Servo Amplifier Schematic
G-8	List of References





NATIONAL AERONAUTICS AND SPACE ADMINISTRATION

APOLLO 204 REVIEW BOARD

IN REPLY REFER TO PK

April 5, 1967

TO: Dr. Floyd Thompson  
Chairman, Apollo 204 Review Board

FROM: Chairman, Panel 18

SUBJECT: Open work at the time of submission of Panel 18  
Final Report

The following work activities were incomplete on March 31, 1967, at the time of submission of the Panel 18 Final Report. These activities are in process at the present time, and their completion is required to complete the analysis of the 204 accident:

1. Determine the cause for each circuit breaker found in an open condition following the accident. This requires an examination of spacecraft wiring. This activity may disclose more suspicious wiring areas.
2. Determine the status of all fuses in the spacecraft. Fuses were used in the DC power circuits for instrumentation transducers and instrumentation related equipments. Once the status is determined, then we must determine the cause for each fuse found in a blown condition. As stated above, this requires an examination of spacecraft wiring and may disclose more suspicious wiring areas. It may be necessary to check the rating of certain fuses, and to run special tests on certain fuses to determine their characteristics.
3. Conduct additional continuity checks to establish that selected suspect wiring was installed as required by manufacturing drawings.
4. Examine the Command Pilot's boots in the Metallurgical Laboratory at KSC. The area in question is the condition of the Velcro pad screws to determine if there are any signs of arcing.

**ENCLOSURE G-1**

5. Finish examination of cabin air fan 1 AC wiring in Metallurgical Laboratory at KSC to establish with complete certainty that shorting was an effect of the fire.

6. Finish examination of octopus cable in Metallurgical Laboratory at KSC to establish with complete certainty that shorting was an effect of the fire.

7. Continue water-glycol data analysis. This is required to establish factually and to reach a unified engineering judgement on integrity of the water-glycol loop.

8. Examine the bottom of the lithium hydroxide access door in the Metallurgical Laboratory at KSC to determine if there are any traces of copper.

9. Finish the "Board Action Summary." There are approximately ten TPS's for which the analysis results have not yet been received.

10. Tests are being conducted in which a wire will be sparked with a gas chromatograph connector nearby to determine if any output can be produced. Data analysis will be required after the tests are completed. Tests being conducted on Spacecraft 008.

11. Flammability characteristics of water-glycol and the inhibitor agent, and effects of water-glycol on spacecraft connectors are continuing at KSC and MSC.

12. Boiler plate mock-up fire tests are continuing at MSC.

13. Examination of crushed DC instrumentation harness in ECU must be completed in Metallurgical Laboratory at KSC to positively establish that no wires were shorted or damaged.

14. Analysis of voice tapes during period of fire is continuing at MSC.

15. Conduct of another test on Spacecraft 008 to establish with certainty the Guidance and Navigation output data differences between a DC short and a DC open condition on the supply to the inverter.

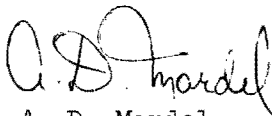
  
A. D. Mardel

**ENCLOSURE G-1**

## Open Circuit Breaker Analysis

The following determinations were made based on an analysis of telemetry data, wiring continuity checks, and visual observations:

### Panel 22 Right-hand Circuit Breaker Panel

#### CB18 Master Events Sequence Controller Arm B

This breaker supplied power to arm the pyro and logic DC B busses. Telemetry data indicated that the breaker was closed well into the fire, at least until loss of signal (LOS).

#### CB15 DC Sensor Signal Main A

This breaker supplied signal voltage to the DC under-voltage sensing unit. Whenever the breaker is opened, a caution and warning alarm is generated. This did not occur, therefore it is concluded that the breaker was closed well into the fire, at least until LOS.

#### CB117 Scientific Equipment Bay 1 Power

This breaker supplied DC bus B power to the Medical Data Acquisition System (MDAS) recorder. The MDAS recorder provided satisfactory data until after pressure shell rupture, therefore the circuit breaker opened after this time.

**ENCLOSURE G-2**

CB118 Scientific Equipment Bay 2 Power

This breaker supplied DC bus B power to Scientific Equipment Bay 2 equipment which was not installed. However, it was found that these wires were shorted in channel "H" of the Lower Equipment Bay (LEB). Analysis disclosed that the shorting was the result of external heating.

CB77 Battery Charger, Battery B

This breaker supplied power to the control circuitry for placing battery B onto the main bus. This circuitry was operative when the batteries were placed onto the main busses late in the fire. The breaker was therefore closed at the time of initiation of the fire.

CB116 Gas Chromatograph AC Power

This breaker supplied AC bus 1 phase A power to the Gas Chromatograph which was not installed for the test. Wires to this unit were found shorted in the LEB. Analysis indicates that they shorted as a result of external heating.

CB45 Telecommunications Group 5

This breaker supplied power to the Earth Landing System (ELS) telemetry indications among other loads. The ELS telemetry data indicated that the breaker was closed well into the fire, at least until LOS.

CB94 ECS H<sub>2</sub>O Accumulator Main A

This breaker supplied power to the H<sub>2</sub>O cyclic accumulator.

Visual inspection indicated that the breaker had a clean stem. The lack of sooting indicates that the breaker had opened after the fire subsided in the area of the panel.

CB76 Cabin Air Fan 1 AC1 Phase A

This breaker supplied phase A of AC bus 1 power to cabin fan 1. Wires were found shorted near the connector of the fan. Analysis has disclosed that the wires shorted as a result of external heating.

CB74 Cabin Air Fan 1 AC1 Phase C

This breaker supplied phase C of AC bus 1 power to cabin fan 1. Wires were found shorted near the connector of the fan. Analysis has disclosed that the wires shorted as a result of external heating.

CB33 ECS Suit Compressor AC1 Phase A

This breaker supplied phase A of AC bus 1 power to Suit Compressor 2. Telemetry data indicated that a compressor was running through LOS, therefore the circuit breaker was closed during the initial portion of the fire. Wires were found shorted near the connector of the compressor. Analysis has disclosed that the wires shorted as a result of external heating.

CB32 ECS Suit Compressor AC1 Phase B

This breaker supplied phase B of AC bus 1 power to Suit Compressor 2. Telemetry data indicated that a compressor

was running through LOS, therefore the circuit breaker was closed during the initial portion of the fire. Wires were found shorted near the connector of the compressor. Analysis has disclosed that the wires shorted as a result of external heating.

CB92 ECS Waste and Potable H<sub>2</sub>O Main A

This breaker supplied power to the waste and potable water tank transducers in the aft compartment. Wiring to the breaker was found to be shorted in the aft compartment area. This wiring was located in the area of pressure shell rupture, where there was extensive wiring damage.

CB91 ECS Waste and Potable H<sub>2</sub>O Main B

This breaker supplied power to the waste and potable water tank transducers in the aft compartment. Wiring to the breaker was found to be shorted in the aft compartment area. This wiring was located in the area of pressure shell rupture, where there was extensive wiring damage.

CB43 ECS Transducer Pressure Group 2, Main A

This breaker supplied DC bus A power to four ECS transducers

- CF0001P, Cabin Pressure
- CF0005P, CO<sub>2</sub> Partial Pressure
- CF0035R, O<sub>2</sub> Flow Rate
- CF0036P, O<sub>2</sub> Regulator Outlet Pressure



The transducer for CF0005P received DC bus A power only. The other three transducers were powered by both DC busses. The telemetry data from CF0005P were satisfactory well into the fire, at least until LOS, therefore, the circuit breaker did not open until after this time. The wiring harness containing power and signal leads for CF0035R and CF0036P passed under the lithium hydroxide access door and portions of it were totally destroyed by the fire. This wire harness has been previously identified as the probable cause of ignition.

CB34 ECS Transducer Pressure Group 2, Main B

This breaker supplied DC bus B power to three ECS transducers:

CF0001P, Cabin Pressure

CF0035R, O<sub>2</sub> Flow Rate

CF0036P, O<sub>2</sub> Regulator Outlet Pressure

It also supplied power to the O<sub>2</sub> high flow time delay relay. Because the master caution warning light came on at 2331:14.7 GMT, or well into the fire, it can be concluded that the circuit breaker did not open until after this time. The wiring harness containing power and signal leads for CF0035R and CF0036P passed under the lithium hydroxide access door and portions of it were totally destroyed by the fire. This wire harness has been previously identified as the probable cause of ignition.

CB11 ECS Transducer Temperature Main A

This breaker supplied DC bus A power to an instrumentation sensor power supply in the ECU. The power supply then provided power to five signal amplifiers for temperature measurements. Because the power supply also received DC bus B power, no conclusion can be reached as to when the circuit breaker opened. Part of this harness in the ECU has been previously identified as being a suspect cause of ignition.

CB10 Transducer Temperature Main B

This breaker supplied DC bus B power to an instrumentation sensor power supply in the ECU. The power supply then provided power to five signal amplifiers for temperature measurements. Because the power supply also received DC bus A power, no conclusion can be reached as to when the circuit breaker opened. Part of this harness in the ECU has been previously identified as being a suspect cause of ignition.

Panel 21 Right-Hand Side Console Bus Switching Panel

CB8 Sensor Unit AC Bus 2

This breaker supplied power to the AC bus 2 sensor. Visual inspection indicated that the breaker had a clean stem. The lack of sooting indicates that the breaker had opened after the fire subsided in the area of the panel.

Panel 25 Left-Hand Circuit Breaker Panel

CB33 SCS B and D Roll Main B

This breaker supplied power for RCS engine firing. Telemetry data indicated that the voltage was present well into the fire, at least until LOS.

CB39 SCS Pitch Main B

This breaker supplied power for RCS engine firing. Telemetry data indicated that the voltage was present well into the fire, at least until LOS.

CB31 SCS Yaw Main B

This breaker supplied power for RCS engine firing. Telemetry data indicated that the voltage was present well into the fire, at least until LOS.

CB26 Gimbal Motor Control 1 Pitch Battery A

This breaker supplied power to a gimbal motor control switch in the Service Module. Bare wiring to this breaker was found in the lower right hand area near the circuit interrupters. Telemetry data of the battery bus voltage and current indicated no anomaly before or during the fire.

CB24 Gimbal Motor Control 1 Yaw Battery A

This breaker supplied power to a gimbal motor control switch in the Service Module. Bare wiring to this breaker was found in the lower right hand area near the circuit interrupters. Telemetry data of the battery bus voltage and current indicated no anomaly before or during the fire.

CB16 RCS Propellant Isolate Main A

This breaker supplied DC bus A power to RCS propellant isolation valves in the aft compartment. Wiring to this breaker was found to be shorted in the aft compartment area. This wiring was located in the area of pressure shell rupture, where there was extensive wiring damage.

CB15 RCS Propellant Isolate Main B

This breaker supplied DC bus B power to RCS propellant isolation valves in the aft compartment. Wiring to this breaker was found to be shorted in the aft compartment area. This wiring was located in the area of pressure shell rupture, where there was extensive wiring damage.

CB52 EDS 1, Battery A

This breaker established one of the Emergency Detection System (EDS) busses. Telemetry data indicated that the breaker was closed well into the fire, at least until LOS.

CB53 EDS 3, Battery B

This breaker established one of the EDS busses. Telemetry data indicated that the breaker was closed well into the fire, at least until LOS.

Panel 203

CB3 Inverter 2 Power, Main B

This breaker supplied DC bus B input voltage to inverter 2.

Telemetry data of the output voltage of this inverter indicated that the breaker was closed well into the fire, at least until loss of data. Also, an examination of the circuit breaker stem disclosed that it was clean, indicating that the fire had subsided in the area of the panel before it opened.

Panel 150

CB14 Pyro A Seq. A

This breaker supplied pyro bus A. Telemetry data indicated that the breaker was closed well into the fire, at least until LOS.

CB17 Pyro B Seq. B

This breaker supplied pyro bus B. Telemetry data indicated that the breaker was closed well into the fire, at least until LOS.

CB20 Battery Charger, Battery C

This breaker supplied battery charging power to Battery C. Telemetry data of battery current and voltage indicated no anomalies before or during the fire. Physical inspection of this wiring, which is contained in the right-hand side of the spacecraft, revealed heat damaged insulation in the Panel 150 area. The breaker also had a clean stem indicating that it opened late into the fire.

Panel 204 Instrumentation Power Control

CB3      Essential Instrumentation

This breaker supplied DC power to instrumentation for two Service Module RCS quads. Telemetry data of pressures and temperatures for these quads indicated that the breaker was closed well into the fire, at least until LOS.

**ENCLOSURE G-2**

G-100

## Open Fuse Analysis

The following determinations were made based on an analysis of telemetry data, wiring continuity checks, and visual observations:

### EPS Fuse Box

Electrical checks on the box revealed 4 open fuses. One was Pyro Battery A, two were on AC bus 1 Telemetry, and one was on DC bus A Telemetry. Telemetry data from three of these fuses indicated that they were intact until well into the fire. A short was found in the wiring attached to the fourth fuse in a high damage area on the right-hand side at the floor.

### Instrumentation Fuse Box C28A5

This fuse box was located in the crew compartment. It contained 30 fuses. A continuity check disclosed that 4 fuses were open:

- F3      Supplied power to measurement CF0006P, Surge Tank Pressure. Telemetry data indicated that the measurement was satisfactory well into the fire, at least until Loss of Signal (LOS).
- F19     Supplied power to measurement CS0100X, CM/SM Physical Separation Monitor A. Telemetry data indicated that the measurement was satisfactory well into the fire, at least until LOS.
- F20     Supplied power to measurement CS0101X, CM/SM Physical Separation Monitor B. Telemetry data indicated that the measurement was satisfactory well into the fire, at least until LOS.

F23 Supplied power to a number of Earth Landing System (ELS) measurements. Telemetry data indicated that the measurements were satisfactory until LOS.

Instrumentation Fuse Box C28A8

This fuse box was located in the crew compartment. It contained 30 fuses. A continuity check disclosed that 3 fuses were open:

F4 Supplied power for Mission Control Programmer (MCP) functions for an unmanned configuration. Resistance checks revealed shorted wiring in the aft compartment in the area of pressure shell rupture.

F6 Supplied power to a measurement which was deleted (CF0130P). This was part of the Environmental Control System (ECS) instrumentation wiring destroyed during the fire.

F8 Supplied power to measurement CF0184T, CO<sub>2</sub> Absorber Outlet Temperature. Telemetry data indicated that the measurement was satisfactory until LOS. This was part of the ECS instrumentation wiring destroyed during the fire.

Instrumentation Fuse Box C28A6

This fuse box was located in the aft compartment. It contained 30 fuses. A continuity check disclosed that 2 fuses were open.

F4 Supplied power to measurement CR0001P, RCS Helium Pressure Tank A. Telemetry data indicated that the measurement was satisfactory until LOS.

F11 Supplied power to measurement CR2203T, Temperature on



Oxidizer Valve, Plus Y Engine System B. Telemetry data indicated that the measurement was satisfactory until LOS.

Instrumentation Fuse Box C28A9

This fuse box was located in the aft compartment. It contained 30 fuses. A continuity check disclosed that 1 fuse was open:

F22 Supplied power to two heat shield measurements. Telemetry data indicated that the measurements were satisfactory until LOS.

**ENCLOSURE G-3**



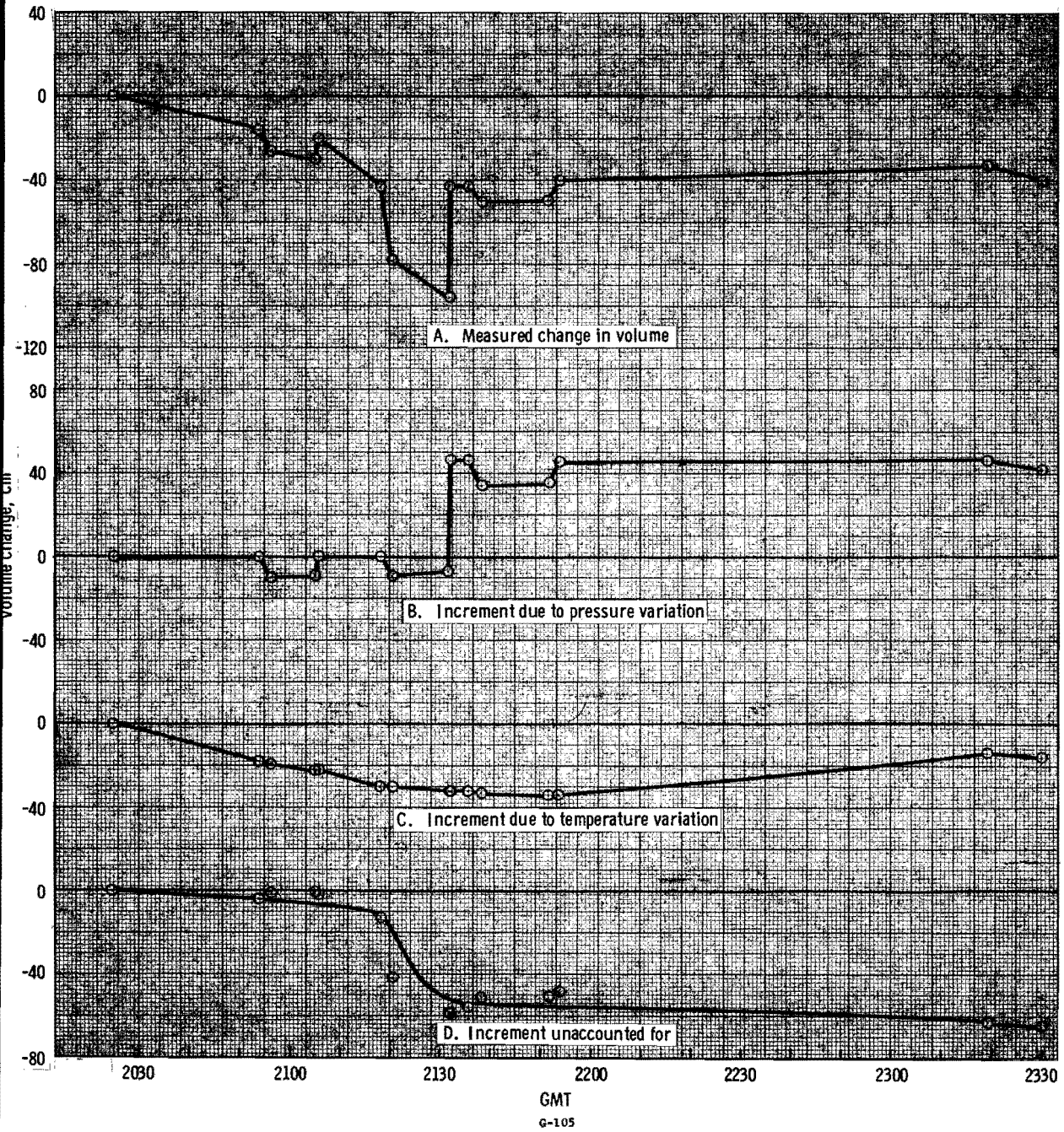

Enclosure G-4: Analysis of measured change of water/glycol volume

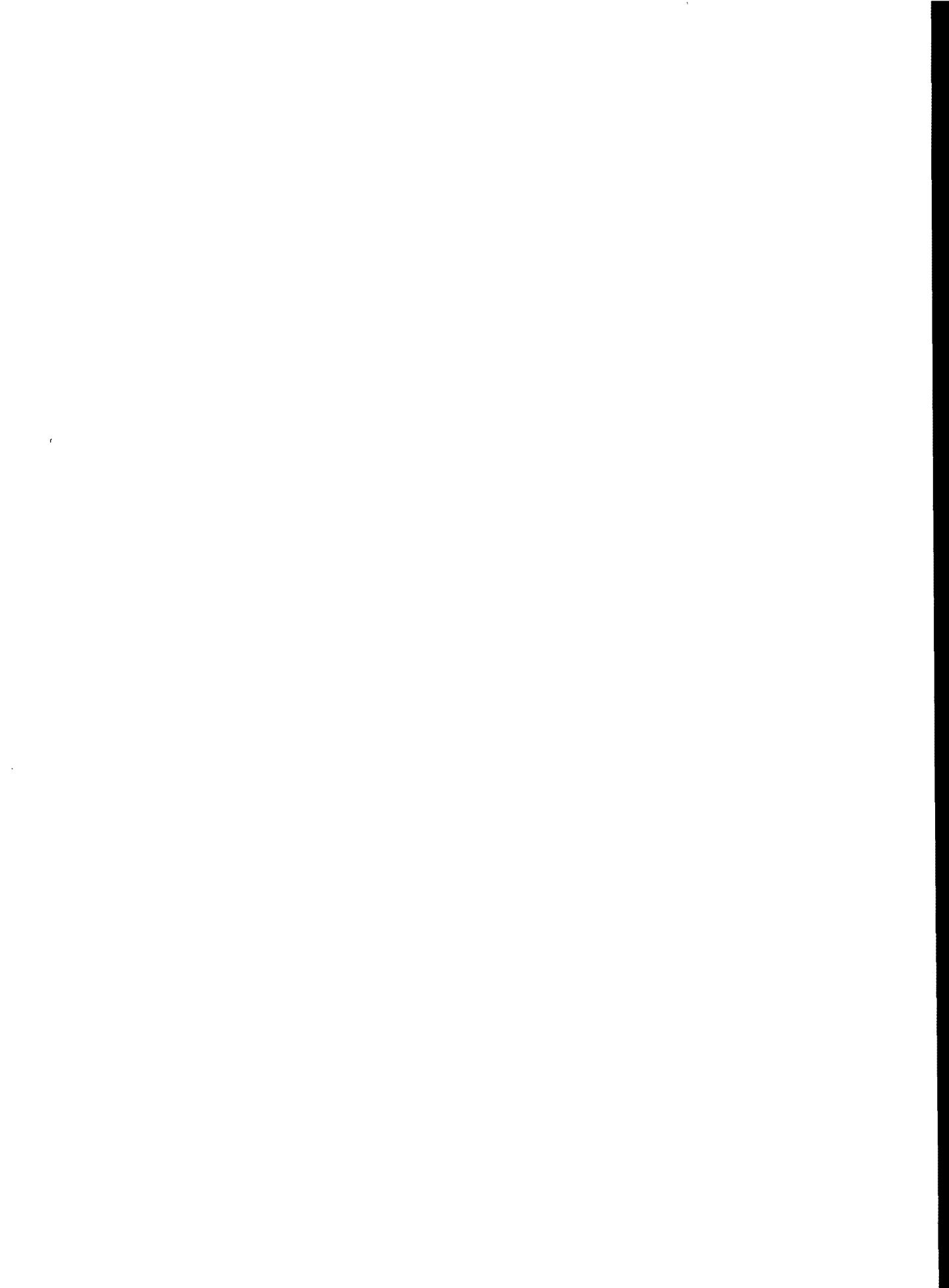

**There is no Enclosure G-5**

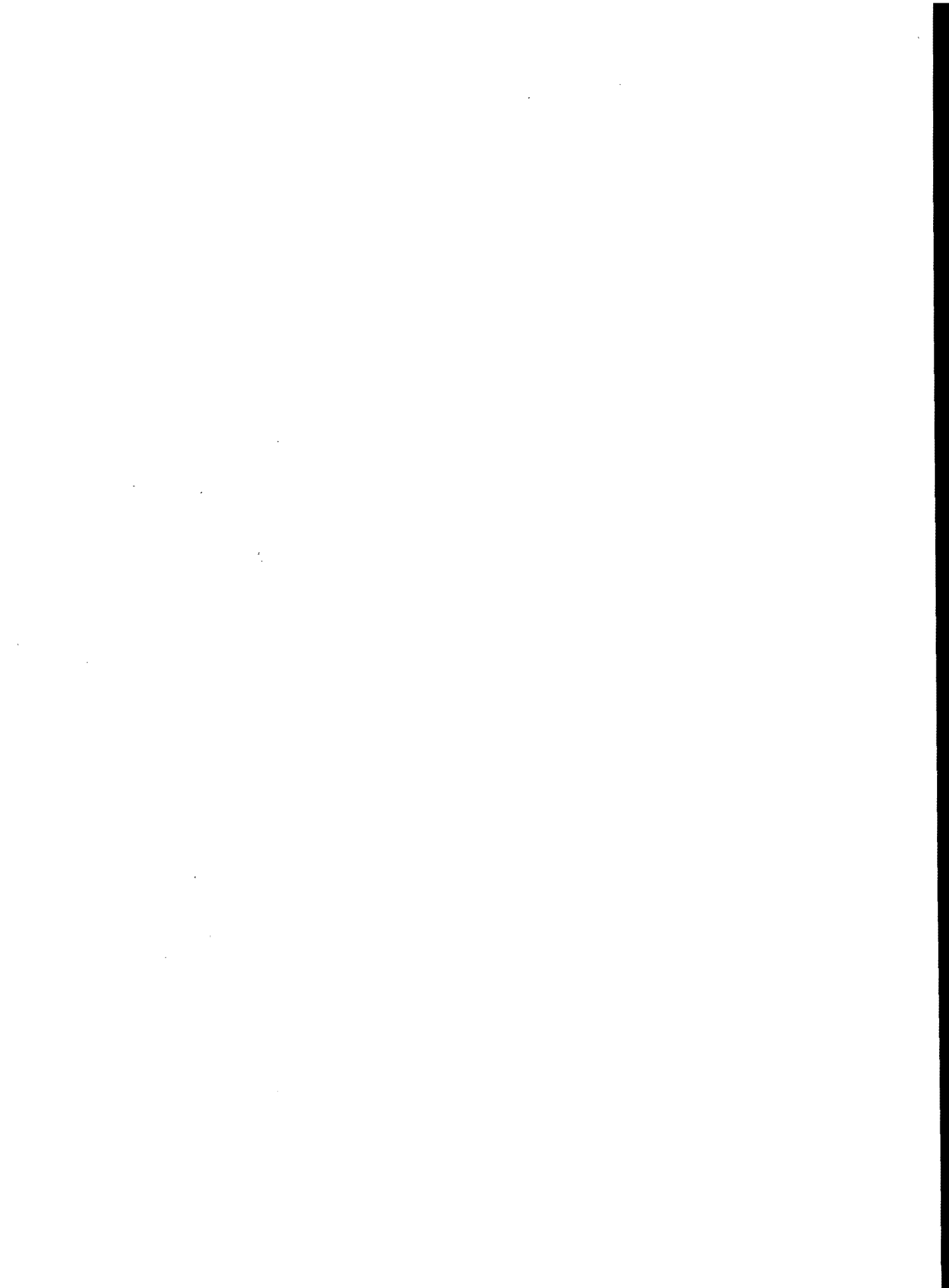

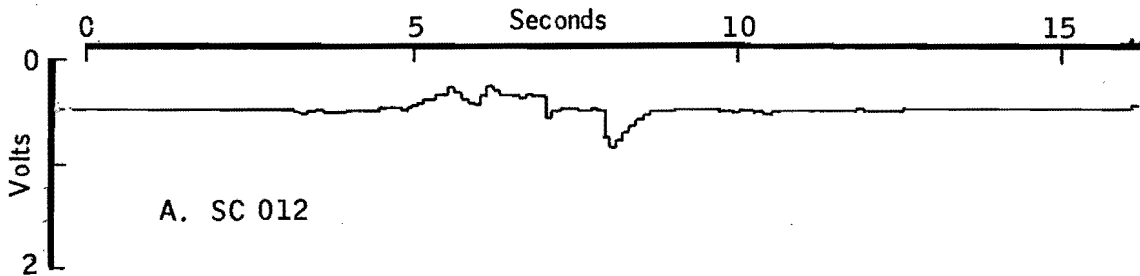

B. Test, result of handling the gas chromatograph cable.

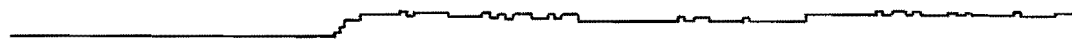

C. Test, result of striking a dc arc near the gas chromatograph cable.  
(Short circuit current greater than 200 amperes)



D. Test, result of applying localized flame on gas chromatograph signal wire.

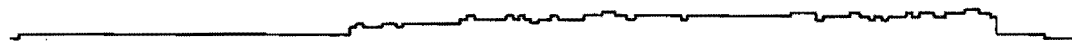

E. Test, result of applying localized flame on gas chromatograph signal wire.

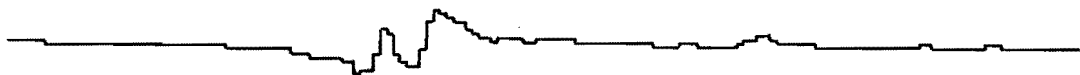

F. Test, result of moving a grounded aluminum plate between  
1 and 12 inches from the gas chromatograph signal wire.

Enclosure G-6: Gas Chromatograph Trace Comparison





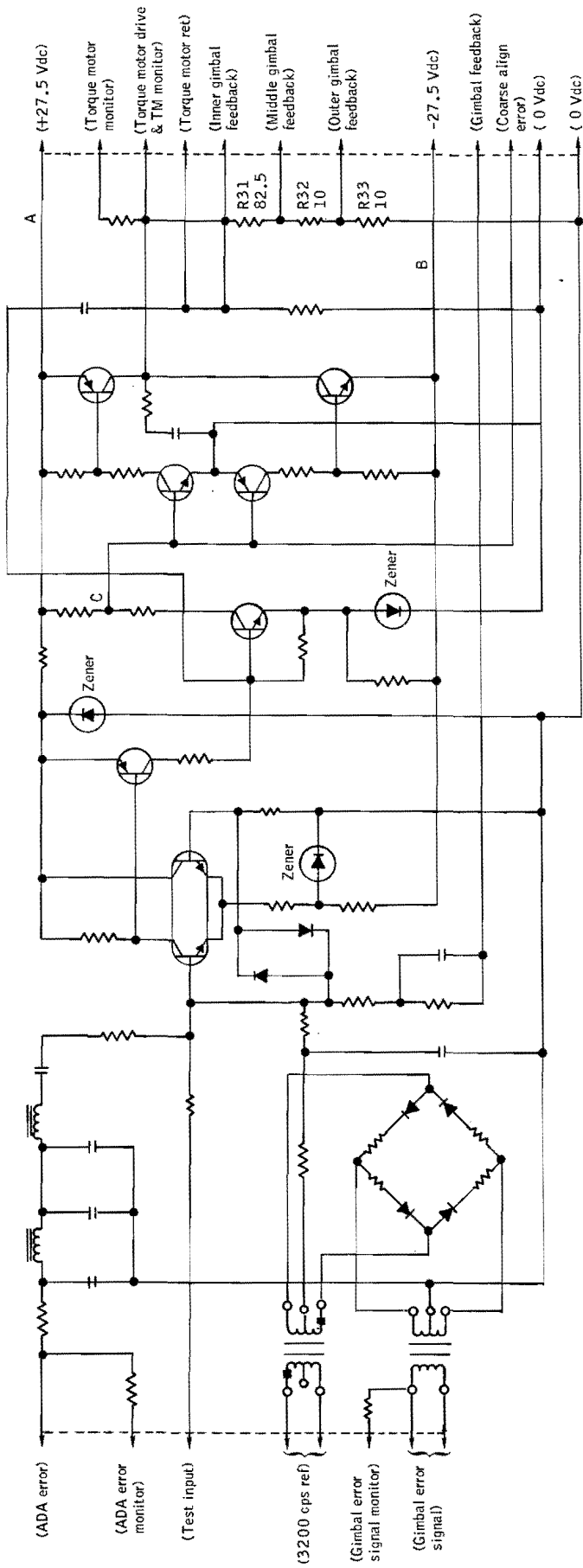

Enclosure G-7: Gimbal Servo Amplifier Schematic

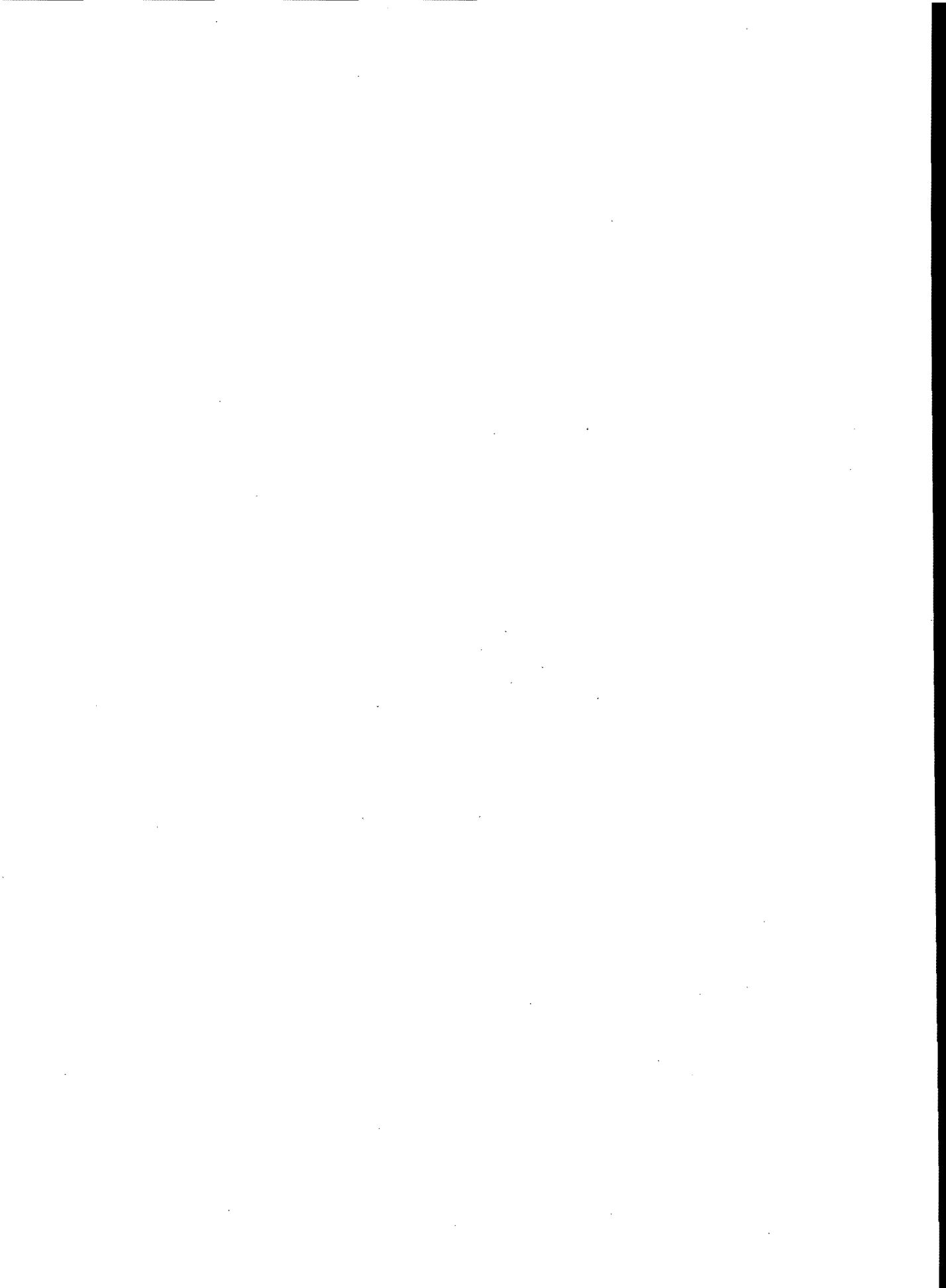

List of References:

<u>Reference</u>	<u>Description</u>
G-1	Final "Board Action Summary", dated May 11, 1967
G-2	"Analysis of Tape Recorded Trans- mission From Apollo Spacecraft 012 on January 27, 1967 Addendum No. 1", dated May 8, 1967
G-3	Complete "Summary of Special Tests", dated May 12, 1967

**ENCLOSURE - G-8**

G-113



SECTION 4

ERRATA SHEET TO APPENDIX D-18

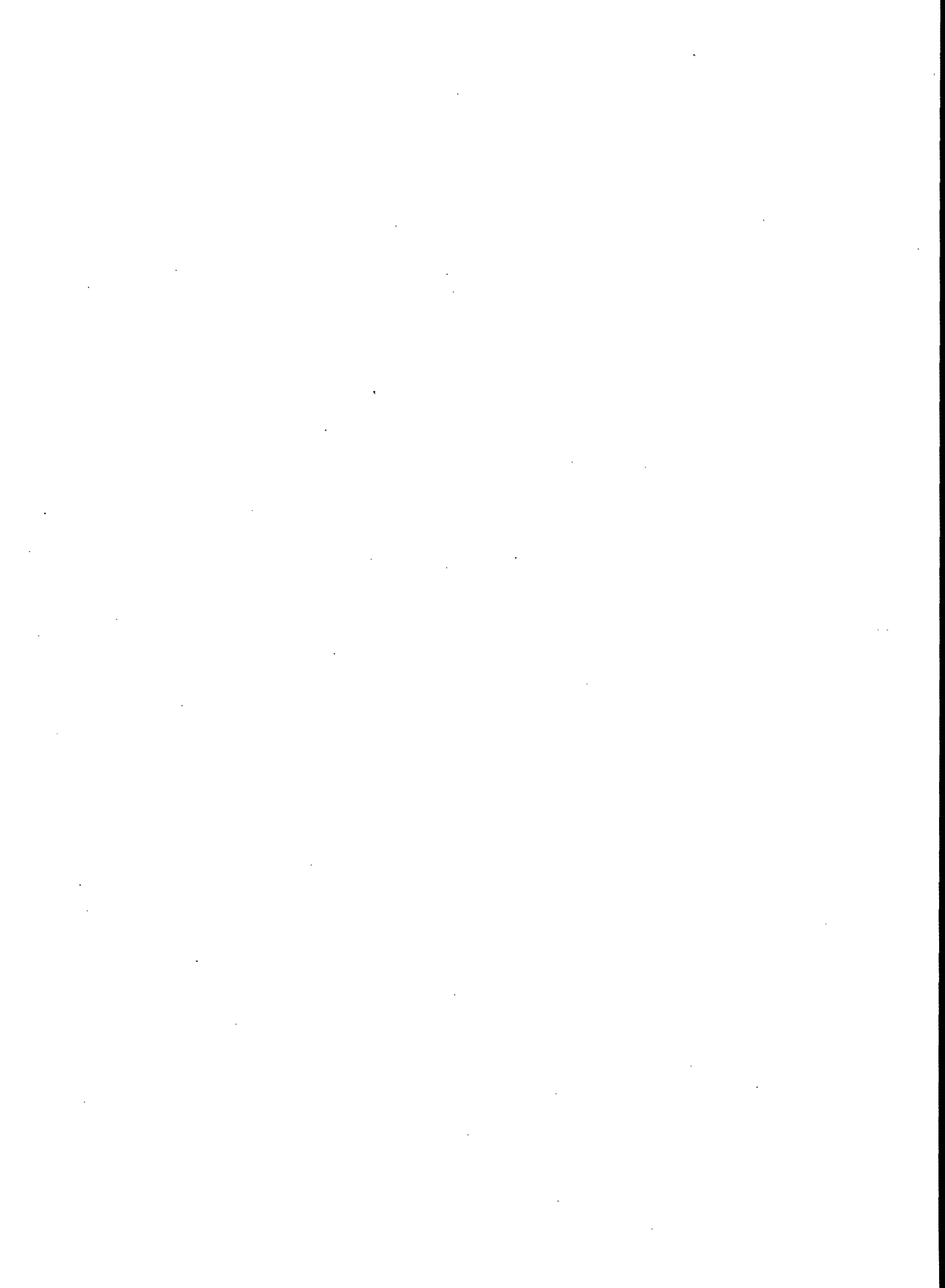



# NATIONAL AERONAUTICS AND SPACE ADMINISTRATION

## APOLLO 204 REVIEW BOARD

IN REPLY REFER TO PK

May 1, 1967

### Corrections to Appendix D-18

<u>Page</u>	<u>Change</u>
D-18-61	One circuit breaker on this page does not have a numerical identification. CB 24 should appear after CB 26.
D-18-13	Chromatograph is misspelled in the sixth line from the top.
D-18-18	Delete the last word "a" in the first line of the third paragraph.
D-18-18	Change "was" in ....respiratory rate was noted .... in the third paragraph, to "were."
D-18-19	In the last two lines on the page, write Inertial Measurement Unit like written here, instead of all capital letters.
D-18-20	In the second paragraph, change 5.5 psig to 5.5 psia.
D-18-20	In the last paragraph, change 21:31:20 GMT to 23:31:20 GMT.
D-18-21	In the last line of the second paragraph, Figure 18-18 should be changed to Enclosure 18-20.
D-18-83	Enclosure 18-22 needs a page number.
D-18-63	Enclosure 18-5 needs a page number.
D-18-33	In the last line, change 8-A to C-8.
D-18-34	Add the underlined words to the first line of the third paragraph from the bottom:  Spontaneous combustion has been considered <u>as a source</u> . <u>An</u> extensive series of tests involving .....
All	None of my black and white photographic enclosures contain any page numbers.

<u>Page</u>	<u>Change</u>
D-18-35	In the fourth line of the last paragraph, change "harness" to "harnesses."
D-18-38	In the second paragraph, add the underlined word: .....just to the left <u>of</u> inverter 3.
D-18-41	In the third paragraph, the word occasionally is misspelled.
D-18-41	In the fifth line of the second paragraph: Enclosure 18-35 should be Enclosure 18-34.
D-18-43	In the last sentence of the second paragraph, delete every word after "Enclosure 18-41 shows ....."
D-18-48	In the first line of the second paragraph, the word attributed is misspelled.
D-18-49	In the fifth line from the top, the word inadvertent is misspelled.
D-18-49	In the fourteenth line from the top, change "telemetry date is" to "telemetry data are."



SECTION 5

REPORT OF TEST RESULTS - PANEL 8





NATIONAL AERONAUTICS AND SPACE ADMINISTRATION

APOLLO 204 REVIEW BOARD

IN REPLY REFER TO PR-67-122

**JUN 13 1967**

TO : Dr. Floyd Thompson  
Chairman, Apollo 204 Review Board  
Langley Research Center, NASA  
Langley Station  
Hampton, Virginia 23365

FROM : W. M. Bland, Jr.  
Chairman, Panel 8

SUBJECT: Test Results for Appendix G to the Final Report of  
Apollo 204 Review Board (TPS MA-016)

Enclosed are the final test results covering the Cobra Cable Spark Test, TPS MA-016. These test results are for Appendix G to the Final Report of Apollo 204 Review Board.

  
William M. Bland, Jr.

Enclosure





## Test Equipment and Instrumentation

The flight equipment used came from Spacecraft 012 spares and the Spacecraft 014 vehicle. Crew equipment was supplied by NAA Crew Systems.

The associated instrumentation and test equipment were supplied by Bioinstrumentation and the Environmental Test Lab at KSC.

### S/C Flight Equipment

<u>Description</u>	<u>Part Number</u>
Audio Center	ME 473-0021-003
Audio Control Panel #26	V16-771226
Audio Warning System	S/C 014 Equipment
Cobra Cable	V16-601263-41
Experiments Tee Adapter	V16-601396
Noise Limiter	V16-601549
Pressure Garment Adapter	V16-601357-31
Skull Cap, Headset	XA-1991-000
Spacecraft Battery	4095-3A (Test Only)
Torso Harness	SL. 103120E

### Instrumentation and Test Equipment

Biomedical PIA Rack	SCG-100137
CEC, Light Beam Recorder	-
Chamber Vacuum Pump	-
Differential Voltmeter	-
Flammability Test Chamber	-
Hewlett Packard 1 kc Tone Generator	-
Physiological Simulator	SCB-1005007
Pressure Gauge	-

## Instrumentation and Test Equipment (cont'd)

<u>Description</u>	<u>Part Number</u>
Test Chamber Adapter Cable	SCC-105024
Tektronix, Oscilloscope	-
Tektronix, Time Mark Generator	-
Various interconnecting Boxes and Cabins	-
16 mm 100 frame/second Camera	-

### Test Preparation

Three operational modes were investigated during the test. Mode #1 used all possible crewman cabling, external to suit, with the exception of a sleep adapter which was not in the umbilical at the time of the S/C 012 incident. The system, Figure I, was configured such that three power circuits could be examined. The system consisted of right mike power 28.0 vdc at 4 ma, left mike power 28.0 vdc at 4 ma, and bioinstrumentation power 16.8 vdc at 60 ma. Six signal circuits were also operated. They consisted of mike, earphone, audio warning, electrocardiogram #1 and #2, and impedance pneumograph. The above power and signals were operating at the time of each separation and their levels are reflected in Table I.

The flammability test chamber was built and operated by the Material Analysis of Kennedy Space Center. The chamber design allowed two electrical feed thrus by which electrical power and the associated signals could enter. In addition to the electrical ports a mechanical feed thru allowed the disconnecting and remating of the connectors while maintaining a suitable chamber environment.

Prior to the initial separation of the connector, the cables were allowed to oxygen soak for a six hour period at  $16.4 \pm .2$  PSIA. The first separation was in an environment of 95% oxygen. Color pictures, 16 mm, 100 frame/second, were taken to record action, sparks, and ignition if it occurred.

The second disconnect was made in 0.5% MEK. MEK was introduced into the chamber by evacuating the chamber to 0.5 PSIA or less. MEK was introduced at the low pressure by a syringe through a rubber port. After completed evaporation, the chamber was back filled with 100% oxygen. With the environment established the connectors were repeatedly broken. The above procedure was repeated for each subsequent run.

Operation Mode #2, Figure II, deleted the tee adapter and the associated biomedical power and signals. The communication network was identical to that of Mode #1. The purpose of Mode #2 was to check the possible arcing or ignition from the communication circuit to the open ended bioinstrumentation circuits.

Operation Mode #3 was a failure mode. The failure mode simulated the failure found in the Spacecraft Command Pilot torso harness after the incident. (Ref. TPS CM-CA-075). Essentially, two shorts were found: mike signal, return and shield, and earphone signal, return and shield. The shorts were accomplished by physically shorting the pins inside the Microdot connector of the torso harness. The test was run with only communication circuits operating.

#### Disposition of Data and Parts

The associated data, including strip charts, waveform pictures, etc. were turned over to NASA Quality Surveillance to be filed with the buy-off copy of TPS MA-016.

Test and flight equipment were returned to the lending groups.

#### Results

Several separations and remates of the noise limiter-pressure garment adapter interface, at concentration of methyl-ethyl ketone (MEK) of 0.5%, 2.5% and 12.5% (saturation) yielded no visible arcing or ignition. The above was repeated in Mode #2 and Mode #3 operation and again no sparks were visible to the observers.

Later review of the 16 mm 100 frame/second film yielded no further information.

#### Discussion

The Final Cobra Cable Spark Test was proposed to investigate the possibility of the Spacecraft 012 fire beginning with the disconnecting or mating of a crewman's electrical umbilical. In view of the fact that the Spacecraft Command Pilot had disconnected his noise limiter-pressure garment adapter interface either before, at the onset, or during the fire, prompted the Cobra Cable Test.

A preliminary test (Ref. Preliminary Cobra Cable Spark Test Report, dated March 1, 1967) was run to investigate the power circuits. Right and left mike power circuits, along with biomed power circuits, were investigated at their normal operating levels. When normal operation failed to yield ignition the biomedical circuit was shorted and again the connectors were separated without any ignition.



Based on a value of 0.002 millijoules and operating currents of 60 ma and 10 ma, an induction of 0.111 mH for the biomedical circuit and 40 mH for the communications circuit is necessary to store enough energy for ignition. In view of the fact that the biomedical circuit is approximately 10 micro-micro farads and the communication network is less than 40 mH, it is expected that no ignition would occur.

Without ignition during the preliminary test the final test was run to investigate the possibility of the signal levels and associated power circuits igniting a flammable mixture.

The data obtained from the preliminary and final tests produced no indication that mating or separating a crewman's electrical umbilical, with the normal operating level, presented any threat to crewman safety. However, this is in no way a recommendation that the practice of mating and disconnecting connectors, with power on, should be approved or allowed.

#### Conclusion

Based on the data obtained from the Preliminary and Final Cobra Cable Spark Tests it is concluded that the disconnecting and/or mating of a crewman's electrical umbilical neither started nor contributed to the AS204 fire.

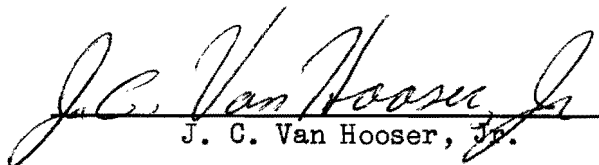
  
J. C. Van Hooser, Jr.

  
W. R. Steiges



## APPENDIX

<u>Item #</u>	<u>Description</u>
Figure #1	Mode #1 Operation
Figure #2	Mode #2 Operation
Figure #3	Mode #3 Operation
Table #1	Power and Signal Levels
Photographs (7)	Test Setup



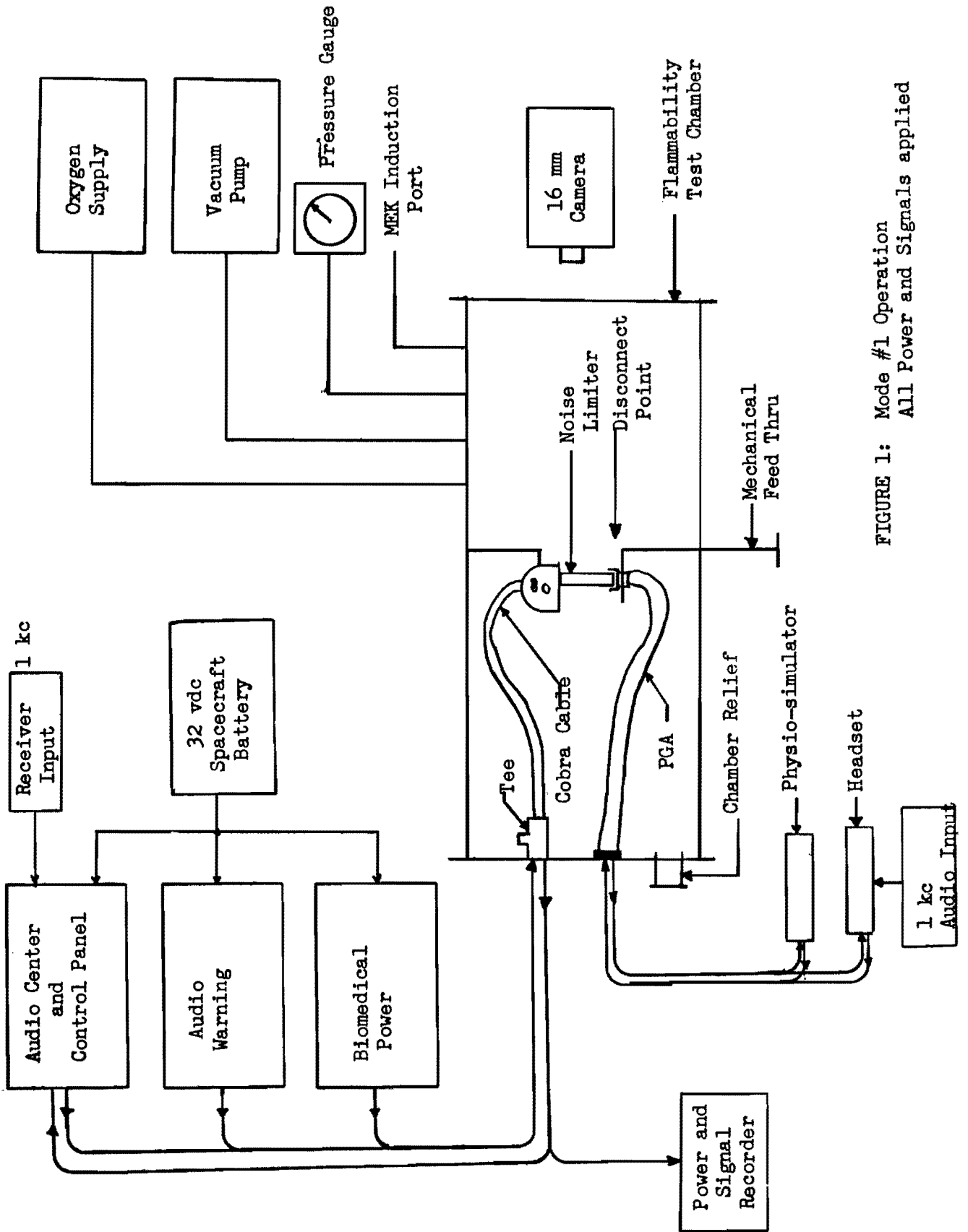

FIGURE 1: Mode #1 Operation  
All Power and Signals applied

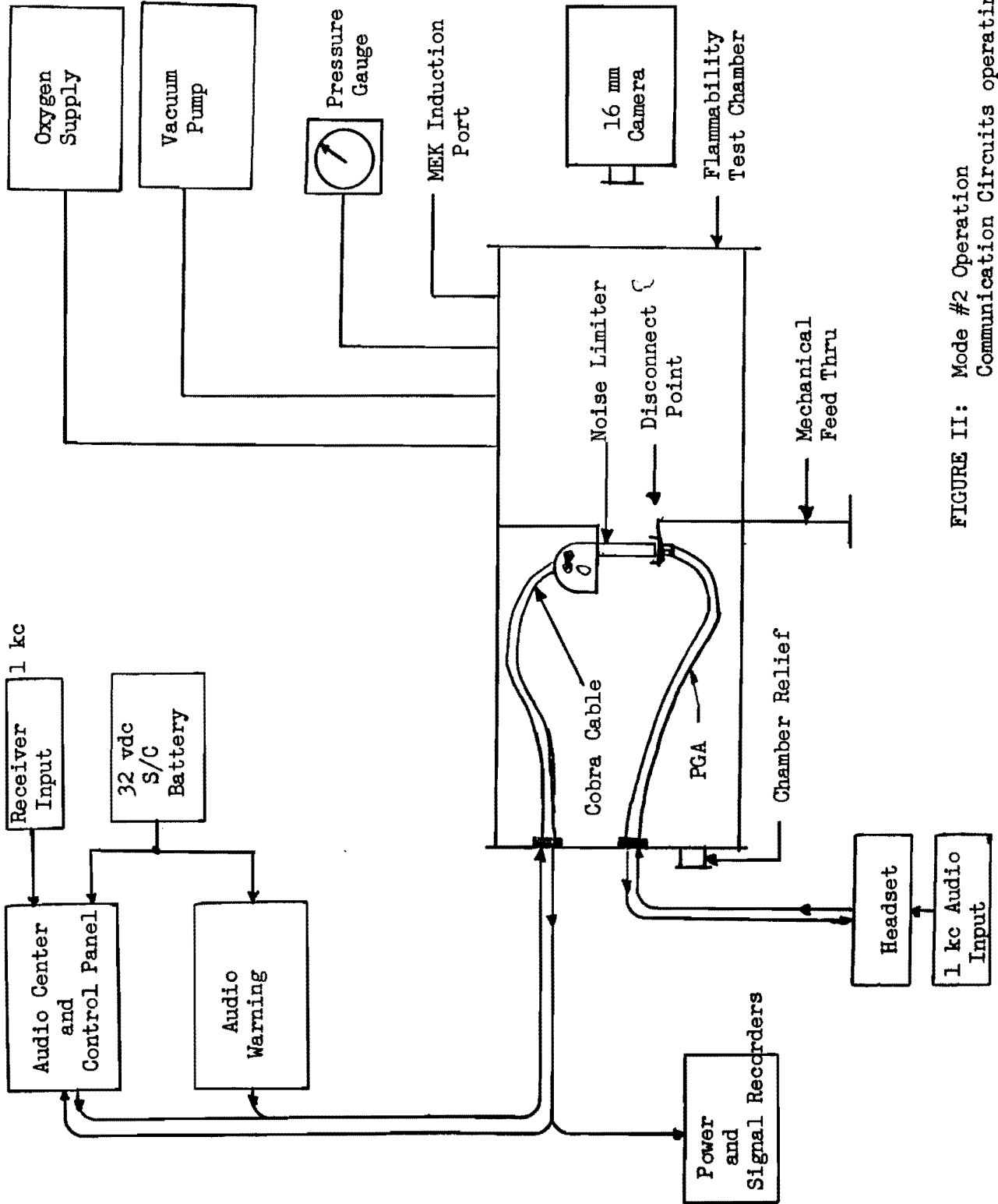

FIGURE II: Mode #2 Operation  
 Communication Circuits operating with  
 Blomedical Circuitry, open.

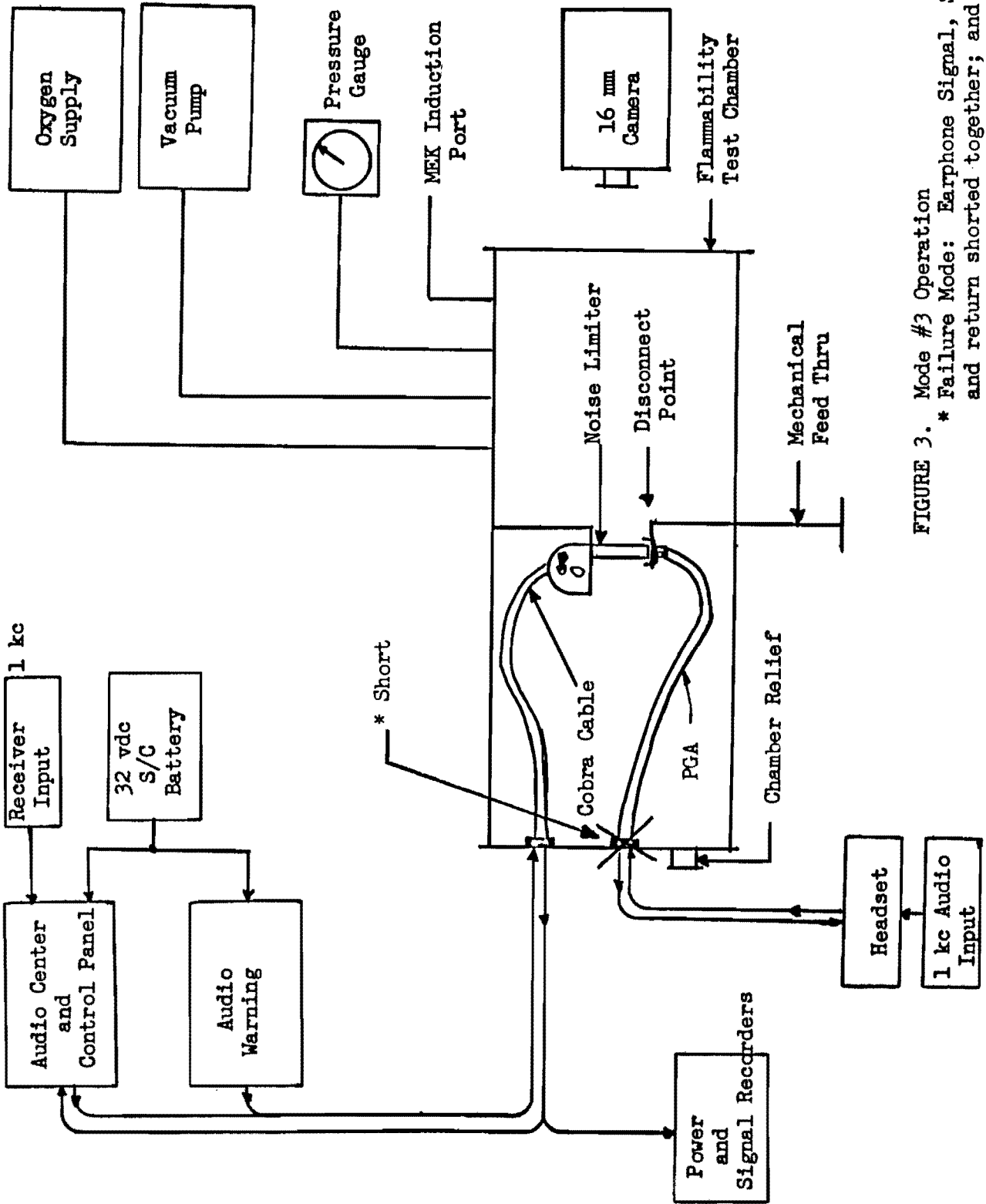
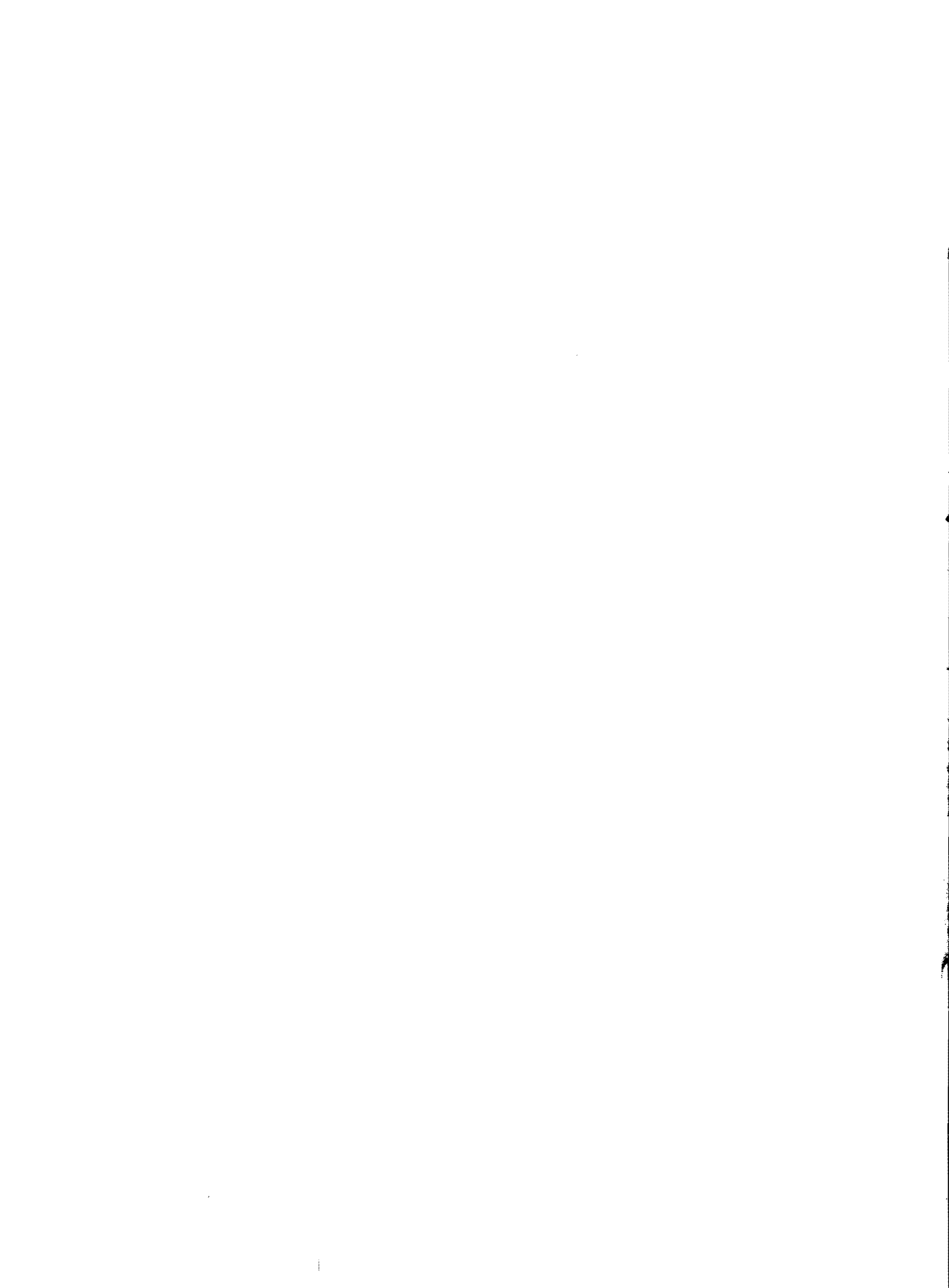

FIGURE 3. Mode #3 Operation  
 \* Failure Mode: Earphone Signal, Shield and return shorted together; and Mike Signal, Shield and return shorted together.

TABLE I

<u>Description</u>	<u>Voltage</u>	<u>Current</u>	<u>Power Level</u>
Right Mike Power	16.8 vdc	4 to 8 ma	-
Left Mike Power	16.8 vdc	4 to 8 ma	-
Biomedical Power	16.8 vdc	50 to 60 ma	-
Mike Signal	-	-	-10 dbm input to Audio Center
Earphone Signal	-	-	0 dbm
Audio Warning Signal	330 mv	-	-
ECG #1	0-5 v	-	-
ECG #2	0-5 v	-	-
Respiration rate	0-5 v	-	-





SECTION 6

REPORT TO DEPUTY ADMINISTRATOR, NASA





NATIONAL AERONAUTICS AND SPACE ADMINISTRATION

APOLLO 204 REVIEW BOARD

May 26, 1967

IN REPLY REFER TO

TO: Deputy Administrator, NASA Headquarters  
FROM: Chairman, Apollo 204 Review Board  
SUBJECT: Report of Completion of Apollo 204 Review Board Activities

As of April 9, 1967, the date of the submission of the Report of the Apollo 204 Review Board to the Administrator, seventeen tests were still being conducted and the panel charged with the analysis of the test results, Panel 18, was instructed by the Board to submit their report of the test results to the Board for approval. To review the report of Panel 18, a Special Subcommittee was appointed by the Chairman on May 12, 1967. This Subcommittee reviewed and accepted, on behalf of the Board, the final Report of Panel 18 on May 16, 1967. Panel 18's report will be incorporated in Appendix G. In addition the Special Subcommittee reviewed the comments of the North American Aviation Corporation relative to the Findings, Determinations and Recommendations of the Board and its Panels. After review, the Subcommittee concluded that no changes were necessary for the Findings, Determinations and Recommendations as originally submitted by the Board to the Administrator. This action completes the Board's Report.

During the course of the investigation, the Board received from various sources about forty items of technical material addressed to flammability and ignition in oxygen atmospheres. It is planned, after coordinating with Manned Spacecraft Center, to designate an appropriate individual within Manned Spacecraft Center to be charged with the responsibility of evaluating and assessing the technical and scientific data contained in this material and to assure that it is made available to cognizant NASA elements.

The files containing the working materials, records, films and tapes are presently being catalogued and indexed. This should be completed by the end of June 1967. The depository is located in Rooms 103 and 105, Building 1195, Langley Research Center. With regard to the Command Module 012 hardware, presently located in the Pyrotechnics Building, Kennedy Space Center, the present plan is that it will be packed for permanent storage only after advice is received that the investigation by the two cognizant congressional committees has been completed and no useful purpose would be served in continuing the display. When it is decided that the Command Module, its components, related drawings and the three spacesuits can be stored, it is planned to remove the storage container from Kennedy Space Center to Langley Research Center.

All the medical records will remain as previously decided at Manned Spacecraft Center in the custody of the Director of Medical Research and Operations.

Letters acknowledging contributions made to the work of the Board were sent to all the Panel Chairmen, representatives of major elements having an interest in the Apollo Program, consultants, and others who worked with the Board. Copies of the letters are enclosed herewith. The Chairman did not take it upon himself to direct correspondence to the agency heads that provided experts and consultants to the Board in view of the fact that the arrangements for the services of those people had been made by the Deputy Administrator.

I think it appropriate to state that the authoritative studies conducted by the OART in its program on Life Support Technology gave me and the other Board Members a great deal of confidence in the Board's position relative to the single gas versus two-gas atmosphere as stated in the Board's Report and as affirmed in our testimony before the Committees of Congress.

Another important development that I wish to emphasize is the flammability testing techniques conducted at Manned Spacecraft Center. All of the Board Members are convinced that tests conducted at Manned Spacecraft Center during the Board's investigation greatly helped the Board in arriving at its recommendations with regard to materials, configuration and wiring protection in the Command Module. More importantly, the new testing techniques constitute an important and valid basis for determining flammability of materials to be installed in the spacecraft.

I suspect that correspondence addressed to the Apollo 204 Review Board will continue for some time, and I recommend that such correspondence be classified into two groups:

1. that which can be answered without follow-on action; and
2. that which is of interest to the Apollo Program Office and requires follow-on action.

The first category could be answered by myself as Chairman of the Board; the other by the Apollo Program Office and the Office of Public Affairs.

The Apollo 204 Review Board respectfully submits that it has fulfilled all of its duties and responsibilities as prescribed by the Deputy Administrator's memorandum of February 3, 1967. Accordingly, it is requested that the Apollo 204 Review Board be dissolved.

Floyd L. Thompson

Enclosures 25



NATIONAL AERONAUTICS AND SPACE ADMINISTRATION

APOLLO 204 REVIEW BOARD

May 25, 1967

IN REPLY REFER TO

TO: Deputy Administrator, NASA Headquarters

FROM: Chairman, Apollo 204 Review Board

SUBJECT: Reply to North American Aviation Comments on Findings of Apollo 204 Review Board

I have studied the memorandum submitted by North American Aviation, Inc. to the Subcommittee on NASA Oversight, Committee on Science and Astronautics, House of Representatives commenting on the Findings, Determinations and Recommendations of the Report of the Apollo 204 Review Board and its Panels. In addition I requested the Special Subcommittee consisting of Dr. Maxime A. Faget, Chairman, Colonel Frank Borman, Mr. George C. White, Jr., and Mr. E. Barton Geer appointed to review the final report of tests from Panel 18, to also review the comments of North American Aviation relative to the validity of the findings of the Report of the Board and its Panels, and in so doing, determine the validity of any claims of erroneous findings. This they did on May 16, 1967, and my comments that follow are based on the Special Subcommittee's report to me.

This review of the North American memorandum shows they concurred in the first nine findings and the eleventh finding. North American did not concur with Finding No. 10b which stated that coolant leakage at solder joints had been a chronic problem. "Chronic" as used in the text of the finding simply means marked by long continuation or frequent recurrence. North American conceded that there had been some leakage. What the Board intended to emphasize was the degree of the leakage problem. Panel 8 made the finding, based on uncontroverted evidence, that there were 35 instances of water/glycol leakage on Block I Spacecraft involving approximately 320 ounces. The details are set out on Pages 18, 19 and 20 of Appendix D-8. It is readily apparent that the Panel 8 findings substantiate the judgment of the Board. In addition the final report of Panel 18, which was accepted on May 16,

1967, stated that there was strong evidence of an additional water/glycol leakage amounting to 50 cc. occurring about two hours prior to the accident. In my opinion, the Finding and Determination of the Board with regard to the coolant leakage at solder joints is valid.

North American Aviation also took issue with the Board Finding 10d, deficiencies in design, manufacture, installation, rework and quality control in electrical wiring. The comments of North American were directed specifically to the design deficiencies in the wiring set out by Panel 9 in Appendix D 9-6. The Special Subcommittee replied to the North American Aviation comments directed to the deficiencies in the electrical wiring as follows:

"In the cases where NAA expressed non-concurrence with the Board and or Panel they often presented incomplete information to support their position. For example, in the case of color coding of wiring (page 11 of the NAA statement) wiring was in fact not color coded in some instances and the numerical coding which NAA claims to use in place of color coding was often missing. (The type of coding and completeness that may or may not have been required by specifications does not invalidate the finding.) Identification tags mentioned on page 15 were also often missing. There were a number of instances during the investigation where no wire identification of any kind was present to permit tracing of circuits. In the question of routing wires 'across and along oxygen and water glycol lines' (item 5 on page 13 of the NAA statement) the statement avoids mention of routing of wires 'across' lines, and only justifies routing of wires along lines 'with secured clearance of one-half inch between wires and the hard lines.' Many of the other NAA statements may be countered in a similar manner.

"It is believed, however, that any statement by the Board in countering the NAA response would make no significant contribution toward clarifying the facts of the matter."

North American has introduced no new significant facts in their argument that vibration testing of Block II Spacecraft would not be of significant value. Their statement relative to



what they term vibration acceptance tests on Spacecraft 009 refers to a test consisting of vibration of this Spacecraft for three minutes along the longitudinal axis at a level of 1 g. Such a test does not replace the purpose of the test recommended by the Board. The ground testing of components to flight levels, the ground acoustic vibration tests of spacecraft elements, and such flight tests that were conducted with Block I Spacecraft are not considered a substitute for the test recommended by the Board. We find no basis for changing the Board's Recommendation.

Floyd L. Thompson

Memorandum for Committee on Science and Astronautics  
Subcommittee on NASA Oversight, of the House of Representatives

This memorandum sets forth the comments of North American Aviation, Inc., on the Findings, Determinations, and Recommendations of the Report of the Apollo 204 Review Board.

The comments follow the same numbering system used by the Board in its Findings, Determinations, and Recommendations.

Before making specific comments, North American believes it important to underscore the concern expressed by the Board in its Preface that its Report might be interpreted as a criticism of the entire manned space flight program and of the many people associated with it. The Board made it clear that this was not its intent, pointing out that it was dealing with the "most complex research and development program ever undertaken" and that the Report was not intended to present a total picture of the program.

The Board did find deficiencies, and North American accepts its share of responsibility. There have been problems in the developmental phase which led to the difficulties described in the Board Report. We believe that the Board has done an excellent job of searching these out and describing them fully. In assessing the Findings, it must be recognized, however, that in space work the standards are and must be extremely high. We have always sought improvements and are continually striving for the goal of perfection.

The Apollo Program is indeed a complex program. Great progress has been made and many outstanding accomplishments have been achieved. Until the time of the accident, the spacecraft and their subsystems had a highly successful series of ground tests to qualify them for a manned flight and there have so far been 13 flight tests of Command and Service Module systems, all of them successful.

We believe it would be a disservice to the many thousands of dedicated people who have contributed to this great project not to remind the Committee of past accomplishments and to express the confidence which North American has that the Apollo Command and Service Module Program is sound, and that a solid basis exists for moving forward to a successful completion.

#### FINDING NO. 1

North American concurs with this Finding and with the Determination as to the most probable initiator. We have noted the other nine possible ignition sources, and on the basis of our participation in the conduct of tests and analyses, concur with the Findings that the most probable initiator was an electrical arc in the sector between -Y and +Z spacecraft axes.

#### FINDING NO. 2a

North American concurs with Finding 2a that the amount and location of combustible materials in the Command Module must be severely restricted and controlled.

The Mercury and Gemini materials (nonmetallic) testing was limited to testing for toxicity and outgassing, and did not include spark ignition testing. Therefore, North American initiated the development in 1963 of criteria for testing the ignition point of individual materials in an oxygen environment. These criteria were incorporated into a North American specification which was reviewed with NASA. The criteria used by North American in this testing was "no ignition below 400° F in 14.7 psi, 100 percent oxygen environment with spark impingement." Possible materials for use in the spacecraft were divided into functional and chemical classes and 178 materials representing worst case samples of these classes were tested. Of the materials tested, 22 materials and those associated by chemical classification were rejected. The approximately 1,800 organic materials used in the spacecraft were all measured against the established criteria and the results of testing. Limited utilization of materials that did not meet these criteria was made on the basis: (a) that a small quantity was used, or (b) that there was a minimum exposed surface area, and (c) that there was no adjacent ignition source, or (d) that the material was protected from a potential ignition source.

Notwithstanding this emphasis on the potential problems created by combustibles in the spacecraft, it can be seen in retrospect that attention was principally directed to individual testing of the material. What was not fully understood by either North American or NASA was the importance of considering the fire potential of combustibles in a system of all materials taken together in the position which they would occupy in the spacecraft and in the environment of the spacecraft.

#### FINDING NO. 2b

North American concurs with Finding No. 2b and the Determination and Recommendation. However, see Finding No. 5 for our comments on "hazardous test."

North American has recommended that NASA conduct a feasibility study as to the use of air in the Command Module on the launch pad instead of 100 percent oxygen. It is recognized that there are a number of considerations involved which must be evaluated, such as the design of suits and the repressurization of the spacecraft with oxygen while in orbit.

#### FINDING NO. 3

North American concurs.

#### FINDING NO. 4

North American concurs. The Command Module inner hatch was designed with emphasis on reliability and crew operation during space flight.

A maximum allowable cabin leak rate of 0.2 pound of oxygen per hour resulted in a design utilizing internal pressure to assist in sealing the hatch. An important safety factor provided by this design was the prevention of inadvertent opening of the hatch in flight. It was decided by NASA that the hatch should permit a 90-second egress time at pressures up to 0.5 psi above ambient. The hatch on Spacecraft 012 met this requirement. It was fully recognized that in the event of an emergency, egress could not be accomplished until the cabin was depressurized, which was to be accomplished by use of a cabin pressure relief valve operated manually by the crew, and post-landing vent valves for venting cabin pressure after landing.

In reaching the final decision on the design of the inner hatch, many factors were considered, including the need for crew safety during lengthy space flights. As pointed out by the Board in its introduction to the Findings, once the Command Module has left the earth's environment, the occupants are totally dependent upon it for their safety, and design features that are intended to reduce the fire risk must not introduce other serious risks to mission success and safety. A wide range of considerations did in fact enter into the trade-off studies in the design of the spacecraft. At one point, North American did propose a hatch which could be opened quickly by use of explosive charges, which was intended for crew egress with parachutes prior to landing operations. This course was not followed because it was considered by NASA that the risk which would be created by an inadvertent opening of the hatch would outweigh the benefits.

North American concurs with the Recommendation of the Board to reduce the required egress time and is working with NASA on a new hatch design to implement this Recommendation. The new hatch includes a clearance around the heat shield which can now be accomplished as a result of flight test data from Spacecraft 011 that verifies safety during reentry when gaps are included in the ablator.

#### FINDING NO. 5

North American concurs with this Finding and Recommendation. We wish to point out, however, as noted in the report of Panel No. 13, that North American's responsibility for identifying hazardous tasks in the preparation of Operational Checkout Procedures is based upon compliance with the guidelines and criteria established in the NASA documents defining the overall safety program at the Kennedy Space Center which includes the procedures concerning the generating and approval of hazardous test documents. These guidelines and criteria had evolved out of previous spacecraft and missile program experience. In identifying "hazardous" operations, the documents are focused on those tests involving fueled vehicles, hypergolic propellants, cryogenic

systems, high pressure tanks, live pyrotechnics or altitude chamber tests. It can be seen that these criteria did not lead to the identification of the spacecraft 012 test as a "hazardous" test. With the benefit of hindsight, it is evident that the criteria were not directed to the potential risk involved in the Spacecraft 012 test. We recognize that North American might well have questioned them even though it did not have the primary responsibility for determining the criteria.

The balance of this Finding dealing with the matter of contingency preparation to permit escape or rescue of the crew relates to NASA responsibilities.

#### FINDING NO. 6

North American concurs with the Determination and Recommendation, subject to the following comment. It is understood that the communications system problems discussed in this Finding are concerned almost entirely with the Ground Communications System, which was not the responsibility of North American. The Spacecraft Communication System operated satisfactorily, with the minor exception of an open microphone condition which did not affect the quality or intensity of communications. We are investigating the open microphone problem, but feel that the Spacecraft Communication System is an effective system, and it did not contribute to the accident.

#### FINDING NO. 7

North American concurs with this Finding. However, Finding 7b requires some clarification. The Ground Test Procedures, in the form of Operational Checkout Procedures, were compatible with the In-Flight Checklists at the time the revision was made. Thereafter, further changes occurred in the In-Flight Checklists at the request of NASA. The few variations which existed between the two at the time of the initiation of the test have been reviewed and are considered to be minor in nature and in no way contributed to the accident.

However, with respect to the statement that test personnel were not adequately familiar with the test procedure, it should be pointed out that all North American test engineers were familiar with the revised procedure at the time of the accident of Spacecraft 012.

North American has already discussed with NASA the need for establishing a period of time, such as 10 days prior to the start of a test, to finalize all changes to the In-Flight Checklists, and the need to establish a 2-day lead time prior to a test for distribution of test procedures.

#### FINDING NO. 8

North American concurs. Full-scale mock-up fire tests are essential to the program from a systems point of view. It should not be the only basis for testing, however, but should be supplemented by testing at a component and/or subsystem level of materials applications as configured for installation in the spacecraft and tested in the environment to which the spacecraft is exposed during ground tests and flights.

#### FINDING NO. 9

That part of this item dealing with combustibles and full-scale mock-up tests has been previously commented on.

With respect to the balance of this item, North American concurs in the necessity of conducting studies of the use of a diluent gas, and had previously proposed in 1963 that it be authorized to conduct studies of this kind.

#### FINDING NO. 10

In the Board Report and in the underlying Report (Panel No. 9) the discussion of design, workmanship and quality control relate only to certain specific areas of the wiring and to the Environmental Control System. North American recognizes the problems which did exist in the wiring and the Environmental Control System. The basic cause of these problems, as discussed in the Panel Report, was that the criteria which established the requirements for North American's design continued to evolve after the design had been started and in fact continued after release of the design to manufacture. We do not believe that a basis exists for construing this Finding as an indictment of the overall design, workmanship, and quality control of the Command Module.

#### FINDING NO. 10a

Environmental Control Systems (ECS) for spacecraft application must meet very demanding performance requirements and are extremely complex. The ECS systems for all previous manned spacecraft programs have experienced developmental problems, the resolution of which was difficult and time-consuming. In the Apollo Program, the requirements both for earth orbit and for deep space operations impose new and more difficult requirements than previously. In developing this system, the developmental subcontractor (the same subcontractor who developed the ECS systems for the Mercury and Gemini Programs) has encountered problems.

Many of the problems were encountered late in the subcontractor's development program. The solution to these problems required modifications to the equipment installed in Spacecraft 012 which required removal and replacement of components in the assembled condition. The Environmental Control System for future missions was being improved to permit easier installation and maintenance. In addition, the improvements will allow some of the tests, which were formerly conducted in the spacecraft, to be conducted at the manufacturer's plant, thereby reducing the number of removals from the spacecraft.

We concur with the Recommendation for a review of the ECS, and NASA and North American have conducted such a review. We are confident that the corrective measures taken will resolve the problems.

FINDING NO. 10b

North American does not concur that coolant leakage at solder joints has been a "chronic" problem, although there has been some leakage. At the time the decision was made to use solder joints one of the considerations was to use aluminum tubing in order to save weight. The most reliable way known to join aluminum tubing was by soldering, taking into account experience and data which had been accumulated in aircraft and other space programs with respect to the use of welds or B nuts. Solder joints have a safety factor of 20 times that of normal working pressure. Care had been taken to eliminate stress in solder joints. It has been found that after installation the tubes can be stressed by external sources causing "creep" which might result in small leaks. "Armoring" and shielding are being designed to strengthen and protect joints in susceptible areas.

FINDING NO. 10c

North American believes that a major change involving testing and selection of a new coolant is not required in view of the very minor combustible properties of the coolant. As the underlying Panel Finding points out, no evidence of deleterious corrosion or corrosion products was noted in examination of test hardware and in post-flight examination of Spacecraft 011.

We believe that armoring and shielding of the solder joints will meet the Board's Recommendation.

FINDING NO. 10d

In order to properly respond to this Finding, which is general in nature, it is appropriate to consider the specific Findings made by the underlying Panel Report (Panel 9) with respect to Spacecraft 012.



As to the cited design deficiencies in wiring:

1. (The wiring in the lower equipment bay was routed through narrow channels having many 90-degree bends.) The design of the wiring in the lower equipment bay was dictated by the "modular concept" approach that was used for the equipment. The channel design, as such, is a standard practice that is followed for the modular concept, and the 90-degree bends are necessary due to the compact design. The bends are within the minimum design tolerance (4 times the diameter of the individual wire) and the corners of the channels are insulated to provide additional protection for the wiring around these bends. Recent test data on teflon cold flow characteristics is resulting in further protection of bends and other pressure points. The reported damage to the protective sleeving, which covers the shield on the wire in these areas, is not detrimental to the wiring insulation or the circuit functional integrity.

2. (Wire color coding practices were not always adhered to as evidenced by the enclosed photograph.) This is an erroneous Finding. Multiple conductor cables are identified with a cable identification number. Individual wires within the cable are color coded while they remain in cable form. Once the cable terminates and branches out as individual conductors, then the connected individual conductors are identified by individual wire numbers and the color coding is no longer applicable. Some instrumentation components purchased, or delivered to us by NASA, have colored wire. The specifications allow them to be used as delivered.

3. (Some areas of wiring showed a dense, disordered array.) This Finding refers to appearance and not to the functional integrity of the wire. It must be recognized that all of the wiring that connects to the Service Module must leave the Command Module structure at a single location to eliminate the need for more than one umbilical. These wires, of necessity, come from all areas of the Command Module. The original installation of the wiring to these feed-through connectors was orderly but due to changes which were ordered after the original installation, disarray did occur in some areas.

This Finding also notes instances of wires being looped back and forth to take up the slack. This is a valid wiring practice. In some cases excessive lengths of wire had to be stored or looped back into the bundle because they were to calibrated resistances for the instrumentation functions, and the instrumentation would be affected if these wires were not to the calibrated lengths. In other cases due to changes which were ordered, equipment was relocated, thereby leaving lengths which could either have been cut and spliced or looped. It was considered that looping was as fully acceptable a practice as cutting and splicing.

There is no evidence that the disarray, which resulted from the conditions described above, affected the integrity of the wiring or in any way attributed to the accident.

4. (A circuit breaker panel was pressed close to a wire harness.) The original design provided sufficient tolerance between close-out panels and wire harnesses behind the panels so that touching would not occur. Our technicians were instructed not to close out panels if there were obstructions or other indications that the wire harnesses may touch the panel. Although there is no indication of shorting or arcing in this panel, or any evidence that it contributed to the accident, it did indicate insufficient clearances of the wiring after panel installation.

5. (There were wires routed across and along oxygen and water-glycol lines.) Routing of wires along hard lines is acceptable with secured clearance of one-half inch between wires and the hard lines. This is a standard and acceptable design practice.

6. (The floor wiring and some connectors in the LEB were not completely protected from damage by test personnel and the astronauts.) The design of the wire harnesses routing and protection in the Block I crew compartment was based upon certain constraints imposed by the combination of weight, lift-to-drag ratio, entry thermal protection for the umbilical connection, and the importance of these factors on safety and reliability in reentry.

The unitized couch provides natural protection during flight and manned ground testing for that portion of the wire harness under the couch. Moreover, while the spacecraft is in orbit there are no weight loads imposed by the astronauts. The basic protection for the wire harness was tough antichaffing teflon wrap. In addition, during the manufacture and check-out of the spacecraft, protective devices in the form of work floors and thick padding were used. In the Block II spacecraft it was possible, because of a relocation of the umbilical, to shorten the wire harness runs and locate them around the sides of the floor where they are protected by metal covers.

As to the cited deficiencies in manufacturing and quality control:

1. (Lack of attention during manufacturing and/or rework is evidenced by foreign objects found in the spacecraft harnesses.) Two instances are cited by Panel 9 of foreign objects in the spacecraft harnesses. There are no indications, however, in the Board Report that these two foreign objects are anything but isolated instances. Such instances indicate, however, the great importance of maintaining the highest standards of quality of workmanship and inspection. North American has recognized that the standards which it has followed in its other programs would, adequate though they may have been for these

programs, have to be brought as close to perfection as possible for manned space work. North American's objective, therefore, has been to seek improvements both in the procedures for workmanship and inspection and in the means of insuring compliance with them.

Improved methods of tracking and retrieving tools and equipment that could possibly be left in the spacecraft are being instituted and a Planned Change Grouping Method has been implemented to accumulate and package changes to be installed at specified periods of the manufacturing and test cycles. These packages of changes are mocked-up, accumulated, and approved and delivered at a scheduled time along with a sequential quality control approved procedure.

2. (Some wiring did not have identification tags.) Some wiring did not have identification tags, but it should be pointed out that this was not an omission. By specification, multiple conductor cables or wires carry identification tags. All single conductor wires are numbered. So far as we can determine, there is no evidence that identification tags were not used at all terminating ends. These methods of identification are very satisfactory.

3. and 4. (Two Hughes connectors were found to be broken or chipped.) This condition on these two connectors might have been caused by improper installation, but they could have chipped from thermal shock and sooted during the fire. There is no evidence in the Board Report that indicates that the connectors were not functioning properly or contributed to the accident.

As to Recommendation 10d, North American had been fabricating wire harnesses by three-dimensional method since March 1966. In the manufacture of wire harnesses for Block II spacecraft North American utilizes three-dimensional jigs which accurately represent a dimensionally correct spacecraft and assures that the harnesses will be built exactly to that configuration. Specifications and drawings have been reviewed and in Block II are verified by computer and design reviews. As Panel Findings have noted, Block II wire harnesses contain flexibility for change and spare wires have been provided to allow for "splice areas" which provides for ease of incorporating changes with least disruption to the basic harness either functionally or in appearance.

#### FINDING NO. 10e

As the underlying Panel Report (Panel 2) has pointed out, the vibration levels for qualification testing of components were originally established on the basis of data from other programs. These data were used to define a spectrum of flight vibration levels which would be expected along each axis of the spacecraft throughout a frequency range

of 20 to 2,000 cycles per second. The components were qualified by subjecting them to a random vibration within this frequency range at the expected flight level. The length of these tests, 15 minutes along each axis, was several times the expected duration of vibratory excitation during atmospheric flight. Some component vibration tests were conducted using an electromagnetic shaker and the remaining components were tested with acoustic excitation.

Unmanned Spacecraft 009 and 011 were actual flight vehicles which, during their suborbital flights, were exposed to boost, orbital and entry vibration conditions. Their primary mission was to qualify the spacecraft for manned flight, complementing an extensive ground acoustic vibration test program which was conducted on representative portions of the entire spacecraft and its subsystems.

North American did conduct vibration acceptance tests on Spacecraft 009 and, based upon the results, agreed with NASA to stop such tests. Structural vibration tests were conducted on Spacecraft 004, and acoustic tests were conducted on the 180-degree sector of the Service Module.

Because of previous tests of flight configured spacecraft and because of the rigorous qualification and acceptance vibration tests conducted on subsystems, our view is that vibration testing of a Block II spacecraft is not of significant value.

#### FINDING NO. 10f

With one exception the spacecraft design and operating procedures do not require the disconnection of electrical connections while powered. The one exception was the "cobra cable," which is the cable by which the crew connects to the spacecraft communication and biomedical systems. Special design precautions were taken with respect to this cable. These included limiting the current to a value of 25 to 100 milliamperes by resistors in the circuit leading to the cables. In addition, the electrical connection is broken prior to disengagement of the protective shell, thus preventing exposure to external material. The safe operation of this cable is evidenced by the Panel Report which stated that in a simulated separation test neither arc nor ignition was produced. We are, however, studying the possibility of providing a switch to deenergize the cable prior to disconnection.

#### FINDING NO. 10g

Preliminary studies for fire protection in the form of fire-fighting equipment were made by North American in 1965 and reviewed by NASA. This effort was not pursued since it did not appear that feasible fire-fighting protection could be designed and installed in the spacecraft. As NASA

has explained, additional study and tests are planned to determine whether technology can be developed to permit the design of effective fire-fighting equipment.

FINDING NO. 11a

North American concurs that not all open items were listed in the DD250 shipping document that accompanied the spacecraft at the time of shipment. However, a revised DD250 was prepared by North American and accepted by NASA on September 27, 1966, which documented officially the shipped configuration.

During the preparation of Spacecraft 012 for shipment from Downey, North American had agreed with NASA to include at Downey many items previously planned for field site installation. Revised planning documents were issued calling for the incorporation at Downey of as much of this effort as possible prior to shipment.

Additional emphasis is being placed on compliance with our procedure for a 24-hour cut-off time prior to shipment for turn-in of records of work not completed. This situation related solely to the formalities of timely completion of paperwork, and there is no evidence that it contributed in any way to the accident.

FINDING NO. 11b

North American concurs. Because of the dynamic nature of the test program, certain paperwork formalities were not followed. A pretest constraints list for this test was prepared, however, and NASA and North American Test Conductors did not complete the formality of signing the document. A real-time update of the constraints to the test was made by a daily coordination meeting held by the Operation Engineers for NASA and attended by NASA and North American Systems Engineers. "The Daily Status Report, SC 012" was used to establish the original constraints list and new items that became constraints were scheduled for work during these meetings. On the morning of January 27, 1967, items were signed off of the original constraints list, and oral agreement was reached between NASA and North American that no new constraints had been discovered that were not on the original list. There is no evidence to indicate that the absence of the appropriate formalities contributed to the accident.

FINDING NO. 11c

It is our understanding that NASA has taken action to resolve this situation. This action will aid the definition of the responsibilities of the organizations involved.

FINDING NO. 11d

Of the 829 equipment items required to be certified for the Command Module, only four were not completely certified (i.e., had not completed qualification testing) at the time of the accident. In accordance with NASA requirements, these four items would have been certified prior to flight of the spacecraft. Taking into account the degree of qualification test accomplished on these items, it was considered that these items were suitable for pad testing. Insofar as we can determine from the Board Report, there has been no evidence that any of these four items related in any way to the cause of the accident. The certification or qualification testing achieved on the Apollo Program surpasses that achieved on any other manned spacecraft program at a comparable time in the development program.

FINDING NO. 11e

North American recognizes that discrepancies did exist between specifications which were included into the contract with NASA and a new specification which NASA was generating for use with all contractors. The North American specification was developed in late 1962 and early 1963 (and imposed on all of our subcontractors) to limit the use of flammable materials in the Command Module. North American and NASA engineers conducted a "walk through" of Spacecraft 008 and 012 to review the use and placement of materials. Another "walk through" was planned for Spacecraft 012 prior to launch. Neither of the specifications, however, provided for the system testing of materials which is now considered necessary for a full understanding of the hazard potential.

FINDING NO. 11f

North American concurs with this Finding. The Operational Checkout Procedure implementing the specification was prepared at Kennedy Space Center by North American personnel. As changes were required in the test requirements, Downey engineers were sent to Kennedy Space Center to provide engineering assistance in the rewrite of the Operational Checkout Procedure. The changing test requirements of the test specification in many instances was brought about because of constraints in the field such as ground support equipment or facilities problems or refinement of test procedures. While the test specification was not updated, the Operational Checkout Procedure actually represented the latest configuration of the test specification as affected by changes. We have already instituted action to clarify our specification requirements and procedures on Block II and remedy this problem.

As to the Recommendation under this item, North American concurs that every effort must be made to ensure maximum clarification and understanding of the responsibilities of all the organizations involved in the Apollo Program. It is a program of immense complexity and requires the highest degree of organizational skill, both within the government and industry, to effectively coordinate the efforts of the hundreds of thousands of people who are engaged in Apollo work.

**SECTION 7**

**CORRESPONDENCE**



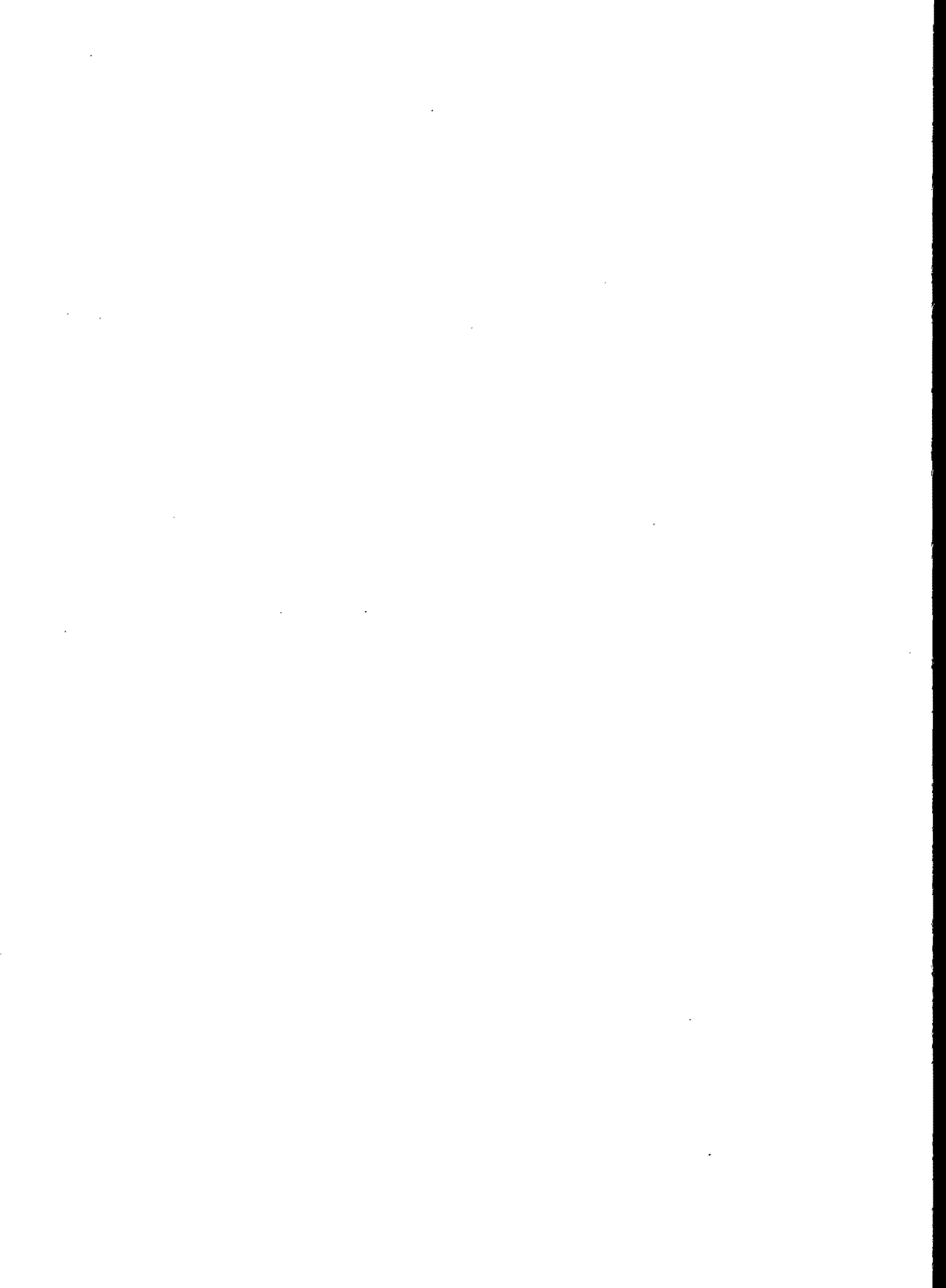



NATIONAL AERONAUTICS AND SPACE ADMINISTRATION  
MANNED SPACECRAFT CENTER  
HOUSTON, TEXAS 77058

IN REPLY REFER TO: PF2-0/260-67

JUN 19 1967

TO : Chairman, Apollo 20<sup>4</sup> Review Board  
FROM : Manager, Apollo Spacecraft Program  
SUBJECT: Release of Command Module 01<sup>4</sup>

Reference: (a) Letter, PP3-67-4/49, dated May 2, 1967, Subject:  
Release of Command Module 01<sup>4</sup>.

(b) Letter dated May 19, 1967, Subject: Request for  
release of Command Module 01<sup>4</sup>.

Reference (a) requested that consideration be given to releasing Command Module (CM) 01<sup>4</sup> for use in the Apollo Program. Reference (b), responding to this letter, stated that CM 01<sup>4</sup> was expected to be released before the end of May.

This letter is being written to reiterate the importance of CM 01<sup>4</sup> to the Apollo Program. Currently, we need to remove some additional hardware, e. g., guidance and navigation equipment.

I would appreciate it if you could release CM 01<sup>4</sup> as soon as possible.

*George M. Low*  
George M. Low



NATIONAL AERONAUTICS AND SPACE ADMINISTRATION  
WASHINGTON, D.C. 20546

OFFICE OF THE ADMINISTRATOR

JUN 21 1967

MEMORANDUM To Dr. Floyd L. Thompson  
Chairman, Apollo 204 Review Board

Subject: Disposition of Apollo 204 Related Material

Discussion with the Congressional committees indicates no further interest in the Apollo 204 related materials. Please proceed to process and store the working materials, records, films, tapes, Command Module 012, components, drawings, space-suits, and other related materials according to the procedures established by the Board.

Dissolution of the Board will be deferred until Congressional activity related to Apollo 204 is completed and there is clearly no further role for the Board. Consequently, the Board should stand as appointed, though without active assignment, until further advised.

A handwritten signature in black ink, reading "Robert C. Seamans, Jr.", is positioned above the typed name.

Robert C. Seamans, Jr.  
Deputy Administrator



NATIONAL AERONAUTICS AND SPACE ADMINISTRATION

APOLLO 204 REVIEW BOARD

June 22, 1967

IN REPLY REFER TO

TO:           Manager, Apollo Spacecraft Program Office  
              Kennedy Space Center

FROM:         Chairman, Apollo 204 Review Board

SUBJECT:      Recision of designation

By letter dated March 1, 1967, I designated the Manager, Apollo Spacecraft Program Office as the custodial agent of the Spacecraft 012 Command Module, systems, components and related drawings. In view of the fact that it has been decided to remove Spacecraft 012 Command Module, etc., from Kennedy Space Center to Langley Research Center, the designation and delegation of authority is hereby rescinded effective this date.

Floyd L. Thompson



NATIONAL AERONAUTICS AND SPACE ADMINISTRATION

APOLLO 204 REVIEW BOARD

June 22, 1967

IN REPLY REFER TO

TO: Assistant Chief, Administrative  
Services Division, Mail Stop 123

FROM: Chairman, Apollo 204 Review Board

SUBJECT: Designation of custodial agent

By letter dated March 1, 1967, you were designated custodial agent of Category 1, reports, files and working materials of the Board.

In view of the fact that Spacecraft 012 Command Module, its systems, components and related drawings are to be permanently stored at Langley Research Center, you are also designated custodial agent of Category 3, Spacecraft 012 Command Module, its systems, components and related drawings.

Floyd L. Thompson

NGASSA

PP HOUMSC KSCFLA

DE NALANG 219 1772045

ZNR UUUUU

P 221320Z JUN 67

FM NASA LANGLEY RESEARCH CENTER HAMPTON VIRGINIA

TO HOUMSC/NASA MANNED SPACECRAFT CENTER HOUSTON TEXAS

ATTENTION MR GEORGE M LOW

INFO KSCFLA/RASPO CODE HS JOHN F KENNEDY SPACE CENTER NASA

KENNEDY SPACE CENTER FLA

KSCFLA/APOLLO PROGRAM OFFICE CODE DA JOHN F KENNEDY SPACE CENTER

NASA KENNEDY SPACE CENTER FLA

BT

UNCLAS THIS IS CORRECTED COPY OF DE NALANG 197 1741512

COMMAND MODULE MOCK-UP AND C/M 014 ARE NO LONGER REQUIRED BY

APOLLO 204 REVIFW BOARD AND THEIR DISPOSITION MAY NOW BE

DETERMINED BY MANAGER, APOLLO SPACECRAFT PROGRAM OFFICE.

SIGNED FLOYD L. THOMPSON CHAIRMAN APOLLO 204 REVIEW BOARD

BT

NNNN

NGA642

RR HOUMSC KSCFLA

DE NALANG 198 1741512

ZNR UUUUU

R 221400Z JUN 67

FM NASA LANGLEY RESEARCH CENTER HAMPTON VIRGINIA

TO HOUMSC/NASA MANNED SPACECRAFT CENTER HOUSTON TEXAS

ATTENTION MR SCOTT H SIMPKINSON

INFO HOUMSC/MANAGER APOLLO SPACECRAFT PROGRAM OFFICE NASA MANNED  
SPACECRAFT CENTER HOUSTON TEXAS

KSCFLA/DIRECTOR JOHN F KENNEDY SPACE CENTER NASA KENNEDY SPACE  
CENTER FLA

KSCFLA/APOLLO PROGRAM OFFICE CODE DA JOHN F KENNEDY SPACE CENTER  
NASA KENNEDY SPACE CENTER FLA

KSCFLA/CODE BJ-3 JOHN F KENNEDY SPACE CENTER NASA KENNEDY SPACE  
CENTER FLA ATTENTION R J REED JR

KSCFLA/RASPO CODE HS JOHN F KENNEDY SPACE CENTER NASA KENNEDY SPACE  
CENTER FLA

BT

UNCLAS

CONFIRMING JUNE 20, 1967, TELECON CHAIRMAN AND R. J. REED, JR. ALTERNATE TO S. BEDDINGFIELD, INTERIM CUSTODIAN OF C/M Ø12 DISASSEMBLY. ACTION MAY BE IMMEDIATELY TAKEN TO STORE C/M Ø12 PARTS, COMPONENTS, SYSTEMS IN CONTAINER FOR SHIPMENT TO LANGLEY RESEARCH CENTER. WHEN REMOVED FROM PIB STORAGE AREA, BOARD JURISDICTION OF AREA CEASES.

DELEGATION OF INTERIM CUSTODIAL AUTHORITY TO CHAIRMAN, PANEL 4 RESCINDED UPON RECEIPT OF C/M Ø12 TO LRC. DELEGATION OF AUTHORITY TO MANAGER APOLLO SPACECRAFT PROGRAM OFFICE, DATED MARCH 1, 1967 RESCINDED.

SIGNED FLOYD L. THOMPSON DIRECTOR

BT



NNNNNGAG44

RR NASAMQ HOUMSC KSCFLA

DE NALANG 200 1741511

ZNF UNUUU

R 221415Z JUN 67

FM NASA LANGLEY RESEARCH CENTER HAMPTON VIRGINIA

TO NASAHQ/EXPLOSIVE RESEARCH CENTER BUREAU OF MINES DEPARTMENT OF  
INTERIOR PITTSBURGH PA ATTN DR ROBER W VAN DOLAH

NASAHQ/CHIEF OF MISSILES AND SPACE SAFETY DIVISION AF INSPECTOR  
GENERAL NORTON AFB CALIF ATTN COL CHARLES F STRANG

NASAHQ/DIRECTOR RELIABILITY AND QUALITY APOLLO PROGRAM OFFICE  
NASA HEADQUARTERS WASH DC ATTN MR GEORGE C WHITE JR

HOUMSC/NASA MANNED SPACECRAFT CENTER HOUSTON TEXAS  
ATTN COL FRANK BORMAN USAF ASTRONAUT

HOUMSC/DIRECTOR ENGINEERING AND DEVELOPMENT NASA MANNED SPACECRAFT  
CENTER HOUSTON TEXAS ATTN DR MAXIME A FAGET

KSCFLA/DIRECTOR SPACECRAFT OPERATIONS JOHN F KENNEDY SPACE CENTER  
NASA KENNEDY SPACE CENTER FLA ATTN MR JOHN J WILLIAMS

BT

UNCLAS

IN ACCORDANCE WITH INSTRUCTIONS RECEIVED FROM DEPUTY ADMINISTRATOR  
JUNE 20, 1967, DISPOSITION OF C/M 012 WAS EFFECTED BY FOLLOWING  
TWX TO COGNIZANT KSC AND MSC PERSONNEL:

"CONFIRMING JUNE 20, 1967, TELECON CHAIRMAN AND R. J. REED,  
JR. ALTERNATE TO S. BEDDINGFIELD, INTERIM CUSTODIAN OF C/M 012

DISASSEMBLY. ACTION MAY BE IMMEDIATELY TAKEN TO STORE C/M 012 PARTS, COMPONENTS, SYSTEMS IN CONTAINER FOR SHIPMENT TO LANGLEY RESEARCH CENTER. WHEN REMOVED FROM PIB STORAGE AREA, BOARD JURISDICTION OF AREA CEASES.

PAGE 2 NALANG 200 UNCLAS

DELEGATION OF INTERIM CUSTODIAL AUTHORITY TO CHAIRMAN, PANEL 4 RESCINDED UPON RECEIPT OF C/M 012 TO LRC. DELEGATION OF AUTHORITY TO MANGER APOLLO SPACECRAFT PROGRAM OFFICE, DATED MARCH 1, 1967, RESCINDED."

BOARD WILL NOT BE DISSOLVED UNTIL ADMINISTRATOR SATISFIED THAT ALL HEARINGS BEFORE COMMITTEES OF CONGRESS ARE COMPLETED. WILL ADVISE WHEN DISSOLUTION EFFECTED.

SIGNED FLOYD L. THOMPSON CHAIRMAN APOLLO 204 REVIEW BOARD

BT

NGAG43

RR KSCFLA

DE NALANG 199 1741511

ZNR UUUUU

R 231440Z JUN 67

FM NASA LANGLEY RESEARCH CENTER HAMPTON VIRGINIA

TO KSCFLA/DIRECTOR JOHN F KENNEDY SPACE CENTER NASA KENNEDY SPACE  
CENTER FLA

INFO KSCFLA/APOLLO PROGRAM OFFICE CODE DA JOHN F KENNEDY'SPACE  
CENTER NASA KENNEDY SPACE CENTER FLA

BT

UNCLAS

ACTION TAKEN THIS DATE AS PER INFORMATION COPY FURNISHED YOUR  
OFFICE TO STORE C/M012 PARTS, COMPONENTS, ETC. FOR SHIPMENT TO LRC.  
LETTER FOLLOWS REGARDING DISPOSITION APOLLO 204 RELATED MATERIALS  
AND RELEASE OF FURTHER RESPONSIBILITY OF KSC.

SIGNED FLOYD L. THOMPSON D, CHAIRMAN, APOLLO 204 REVIEW BOARD

BT

**June 23, 1967**

**TO: Director, Kennedy Space Center**  
**FROM: Chairman, Apollo 204 Review Board**  
**SUBJECT: Removal of Apollo 204 Review Board material**

As you know, the PIB provided storage area for the components and systems of Command Module 012. In addition a Command Module mock-up and Command Module 014 were housed in that building.

I have this date sent TWX's authorizing the removal of C/M 012 systems and components for permanent storage and shipment to Langley Research Center in accordance with instructions received from the Deputy Administrator. I also have authorized the Manager, Apollo Spacecraft Program Office to take such steps as necessary to effect disposition of the mock-up and Command Module 014.

I am furnishing this information to you so that the PIB can be made available to Kennedy Space Center as soon as possible for normal operations.

Upon completion of this action, it is anticipated that the Board will no longer need to call on Kennedy Space Center for further assistance. However, until the Board is formally dissolved by the Administrator, continued liaison with Kennedy Space Center through Mr. Ernest Swieda, Executive Secretary of the Board, would be desirable and wise.

May I once again express my appreciation, and on behalf of the other Board members their appreciation, for your kind assistance and cooperation.

**Floyd L. Thompson**

GTMalley:scw 6-23-67