



# REPORT OF APOLLO 204 REVIEW BOARD

TO  
THE ADMINISTRATOR  
NATIONAL AERONAUTICS AND SPACE ADMINISTRATION

APPENDIX D  
PANEL 18



37718

### **APOLLO SPACECRAFT**

The spacecraft (S/C) consists of a launch escape system (LES) assembly, command module (C/M), service module (S/M), and the spacecraft/lunar module adapter (SLA). The LES assembly provides the means for rapidly separating the C/M from the S/M during pad or suborbital aborts. The C/M forms the spacecraft control center, contains necessary automatic and manual equipment to control and monitor the spacecraft systems, and contains the required equipment for safety and comfort of the crew. The S/M is a cylindrical structure located between the C/M and the SLA. It contains the propulsion systems for attitude and velocity change maneuvers. Most of the consumables used in the mission are stored in the S/M. The SLA is a truncated cone which connects the S/M to the launch vehicle. It also provides the space wherein the lunar module (L/M) is carried on lunar missions.

### **TEST IN PROGRESS AT TIME OF ACCIDENT**

Spacecraft 012 was undergoing a "Plugs Out Integrated Test" at the time of the accident on January 27, 1967. Operational Checkout Procedure, designated OCP FO-K-0021-I applied to this test. Within this report this procedure is often referred to as OCP-0021.

### **TESTS AND ANALYSES**

Results of tests and analyses not complete at the time of publication of this report will be contained in Appendix G, Addenda and Corrigenda.

### **CONVERSION OF TIME**

Throughout this report, time is stated in Greenwich Mean Time (GMT). To convert GMT to Eastern Standard Time (EST), subtract 17 hours. For example, 23:31 GMT converted is 6:31 p.m. EST.

REPORT OF PANEL 18  
INTEGRATION ANALYSIS PANEL

APPENDIX D-18

TO

FINAL REPORT OF  
A P O L L O 2 0 4 R E V I E W B O A R D

This page left blank intentionally.

## A. TASK ASSIGNMENT

The Apollo 204 Review Board established the Integration Analysis Panel, 18. The task assigned for accomplishment by Panel 18 was prescribed as follows:

This task involves the review of inputs from all task groups, the correlation of all pertinent information, feedback for further study, and the final technical integration of the evidence.

## B. PANEL ORGANIZATION

### 1. Membership

The assigned task was accomplished by the following members of the Integration Analysis Panel:

Mr. A. D. Mardel, Chairman, Manned Spacecraft  
Center, NASA  
Mr. R. W. Pyle, North American Aviation, Kennedy  
Space Center  
Mr. C. B. Mars, Kennedy Space Center, NASA  
Mr. D. S. Levine, North American Aviation, Downey,  
California

### 2. Cognizant Board Member

Dr. M. A. Faget, Manned Spacecraft Center, NASA, Board Member, was assigned to monitor the Integration Analysis Panel.

### 3. Panel Consolidation

Panel 16 and 3 served as separate Panels from January 31, 1967, through February 23, 1967. These Panels were dissolved on February 23, 1967, and merged with Panel 18.

## C. PROCEEDINGS

### 1. General

In response to the direction of the Board, the Panel discharged its responsibilities to the Board by planning and executing the following major activities:

- a. Coordination of all phases of hardware inspection, disassembly, test and analysis requirements, and presentation of periodic status and summary of results to the Board.
- b. Correlation, validation, and determination of each significant finding, and presentation of periodic status and summary of results to the Board.

## 2. Hardware Inspection, Disassembly and Analysis

Inputs were solicited from all Panels with respect to hardware inspection, disassembly, test and analysis requirements. A special form, "Disassembly and Post-Disassembly Requirements," (Enclosure 18-1), was used for the logging of all requirements.

In keeping with the analysis activity, priorities for the various requirements were established. Items were then selected twice daily to be approved by the Board for proceeding with that activity of work. Board approval information was fed by the Panel back to the systems engineers so that a "Test Preparation Sheet," TPS, (Enclosure 18-2) would be originated to accomplish this work. This Panel approved all TPS's, kept current TPS files, and reported on the status of all approved requirements by means of a "Board Action Summary" prepared each Wednesday. A sample page of the latest "Board Action Summary" is attached as Enclosure 18-3. All three enclosures relate to the same item: "Removal of a cover over the junction box in the lower left-hand equipment bay."

Significant findings from hardware inspection were then correlated with the analysis effort to determine further courses of activity so as to culminate all research and work on an item and enable a determination to be made. This hardware activity was completed on March 27, 1967. All of the equipment has been removed from the spacecraft.

An examination of the electrical wiring harnesses remaining in the spacecraft in the most probable zone of fire initiation was completed on March 24, 1967. The most probable zone of fire initiation is defined as the area on the Command Pilot side of the Command Module. Looking forward through the main hatch, this area starts at the Environmental Control Unit (ECU) and progresses forward to the gas chromatograph compartment, and covers the volume from the floor to the top of the ECU and to the top of the gas chromatograph compartment. All wiring in the lower

equipment bay was also examined. The ECU wiring has been examined while the unit was in the spacecraft and after removal from the spacecraft.

Electrical Power System wiring inspection and analysis is still continuing. Work items that are active are as follows:

- a. Determination of the cause for each circuit breaker and fuse that was found open or blown after the accident. All open circuit breakers have been identified. The identity of all blown fuses has not yet been established. All circuit breakers that were to be closed but were found open after the accident are listed in Enclosure 18-4.
- b. Conduct of additional continuity checks to establish that suspect wiring was installed as required by manufacturing drawings.

The only evidence of arcs, shorted and suspicious wiring that has been found is listed below:

- (i) DC wiring completely burned through in harnesses providing power to Environmental Control System instrumentation.
- (ii) Arc between a DC wire and the cover of J-Box C15-1A52.
- (iii) Shorted AC wires providing power to the gas chromatograph connector.
- (iv) Shorted DC wires providing power to scientific equipment bay 2.
- (v) Two shorted AC phases in cabin air fan 1 wiring.
- (vi) Crushed DC harness in Environmental Control Unit providing power for instrumentation.
- (vii) Shorted DC wires providing power to the biomed recorder.
- (viii) Shorted AC wires in Environmental Control Unit providing power for suit compressor 2.
- (ix) Command Pilot suit wiring shorted.

(x) Arc on structure by side of switch S11 in back of panel 8.

All removed parts and assemblies were thoroughly reviewed by NASA and Contractor design engineers, metallurgists and Panel 5 members. Based on these reviews, they were classified either as a possible or as an improbable ignition source. A written justification was required for each item, and each item was approved by three design engineers representing NASA KSC, NASA MSC, and NAA, by the three members of the Screening Committee, by the Head of the KSC Materials Analysis Branch, and by a member of Panel 5 before it could be classified as an improbable ignition source.

The listing of all equipment totals 299 parts and assemblies. No attempt was made to list or to remove from suspicion as a possible ignition source the spacecraft wiring or devices integrally a part of that wiring such as terminal boards.

The 299 parts and assemblies were categorized as follows:

System	Number of Parts and Assemblies	Improbable Ignition Source (Cat. B)	Possible Ignition Source (Cat. A)	Remarks
Communications Instrumentation	17 22	17 12	10	9 ECS related transducers 1 harness assembly
Guidance and Navigation Stabilization and Control	16	16		
Environmental Control System	14	14		
Electrical Power System	48 32	3 30	45 2	Static Inverter 2 Panel C15-1A52 (LEB J-Box Cover)



## Continued

System	Number of Parts and Assemblies	Improbable Ignition Source (Cat. B)	Possible Ignition Source (Cat. A)	Remarks
Displays and Controls	30	29	1	Switch 11, Panel 8
Sequencers	6	6		
Reaction Control System	12	12		
Structure	18	18		
Earth Landing System and Recovery Aids	5	5		
Crew Equipment	61	59	2	Command Pilot Cobra Cable, Command Pilot Torso Harness
Experiments	4	3	1	Octopus Cable
Pyrotechnics	14	14		
TOTALS	299	238	61	

The details of the Screening Committee review are contained in the "Screening Committee Final Report," dated March 24, 1967 (Reference 18-1). Analyses of the remaining Category A items are contained in other sections of this report. Special laboratory investigations of spacecraft wiring, the ECS and Static Inverter 2 are reported in this document.

### 3. Correlation, Validation and Determination of Investigation Items

Inputs were received periodically from daily Panel meetings, daily Panel reports, special Panel reports, hardware inspection and disassembly, brainstorming sessions, technical discussions, etc.

The more significant inputs, defined as those that (a) could possibly contribute to the cause of ignition, or (b) could contribute to the propagation of the fire, were listed as investigation items. Each investigation item was

correlated with other items, studied to establish validity and meaning, and finally a determination was made as to whether the item did not cause the accident or whether it may have contributed to the accident.

To better illustrate the mechanics, the process for one investigation item will be summarized:

Investigation Item 42 - Elapsed Time Indicator burned on Spacecraft (S/C) 014. This unit was associated with the Caution and Warning System. Data were received from Panel 6 that an Elapsed Time Indicator (a non-flight item) for the Caution and Warning System was overheated as a result of a noise suppression capacitor short during factory checkout on S/C 014 at North American Aviation, Downey, California. The Command Module filled with smoke during this incident.

The following validation actions were taken:

- (a) Action to Panel 1 to determine the exact configuration of the Elapsed Time Indicator installed on S/C 012 and compared to the S/C 014 installation, and knowledge on whether this unit was installed during the accident.
- (b) Action to Panel 2 to determine the level of qualification with respect to oxygen and pressure environments. Because this unit was to be removed before flight, it was believed that the unit would not have been qualified, but this still had to be confirmed.
- (c) Action to Panel 3 to review all data from S/C 014 during the time that the incident occurred to determine if there were any electrical transients or if any circuit breakers opened, for correlation with indications during the accident.

Closure of these actions disclosed that no changes were made to the unit following the incident on S/C 014, that the unit installed on S/C 012 during the accident was of the identical configuration, and that the unit was not qualified for the environment during the time of the accident. A Board action was then requested to examine the installation on S/C 012 (Board Action No. 0035). A TPS was written (TPS 053) and an examination of the unit was made the next day. The physical

examination disclosed that the unit was in a satisfactory condition with no evidence of burning or damage. The item was then closed in the category of "did not cause the accident."

A "Status of Investigation Items" was prepared for the Board each Wednesday. The latest "Status of Investigation Items" is attached as Enclosure 18-52. Whenever an item was closed, an "Integration Analysis Summary" was prepared and presented to the Board (all are attached as Enclosure 18-53).

Output data from selected Panel activities were reviewed in detail. Examples of these outputs were discrepancy reports and open difficulties provided by Panel 6, and incomplete work or open "Engineering Orders" (EO's) and configuration differences provided by Panel 1. These outputs were reviewed by NASA and Contractor system engineers to determine which could be related to the cause of the accident. Those that could have some bearing on the cause of the accident were entered as investigation items.

#### 4. Special Reports to the Board

Formal and informal reports were prepared and presented to the Review Board. The more significant of these included:

- Review of Spacecraft Power Status
- Supplement to Review of Spacecraft Power Status
- Structural Assessment Report
- Explanation and Discussion of ECS Water/Glycol Circuit Prior to and After the Fire Report
- Spillage of Ethylene Glycol/Water (RS89-a) as a Possible Cause of Fire in S/C 012
- ECS Oxygen System Description and Interim Data Evaluation
- Communications Analysis Report
- Mock-up 2 Mobility Evaluation Test Results

These reports are briefly summarized below.

#### Review of Spacecraft Power Status

This is a summary of internal and external power descriptions and configurations applicable to S/C 012. It contains a sequential history of the DC power system. The sequential history is fully verified by data indications and S/C and Ground

Support Equipment (GSE) switch and control positions. This report was used to establish the DC power system configuration at the time of the accident, and to show that it was proper. (Enclosure 18-54a)

#### Supplement to Review of Spacecraft Power Status

This is a summary of minor internal and external power supplies applicable to S/C 012 in addition to the main DC supplies. (Enclosure 18-54b)

#### Structural Assessment Report

This is the first summary of the visual inspection of the interior of the S/C to determine the extent of damage to the structure, plastic control knobs and glass dials. (Reference 18-2).

#### Explanation and Discussion of ECS Water/Glycol Circuit Prior to and After the Fire Report

This is a summary of the internal and external water/glycol system configuration throughout the test. It also contains a sequential history of significant system parameters. (Reference 18-3)

#### Spillage of Ethylene Glycol/Water (RS89-a) as a Possible Cause of Fire in S/C 012

This report presents laboratory results on the properties of water/glycol and its inhibitor agents. It points out that the residue remaining from any spillage or leakage is hygroscopic and corrosive. It postulates a theory that fire can be produced from electric short circuits caused by glycol/water residue in electrical insulations. (Reference 18-4)

#### ECS Oxygen System Description and Interim Data Evaluation

This is a summary of the internal and external oxygen system configuration throughout the test. It also contains a sequential history of significant system parameters. (Reference 18-5)

## Communications Analysis Report

This report covers the configuration of the complete voice communications system - the Spacecraft, Spacecraft/Ground Interfaces and Ground Systems. It includes detail transmission information during the last ten minutes of the test. (Reference 18-6)

## Mock-up 2 Mobility Evaluation Test Results

This report presents the results of a crew mobility test conducted at KSC. This test was conducted to determine the capability of a crew to see certain areas of the spacecraft and to perform certain actions with respect to time. (Reference 18-7)

### 5. Brainstorming Meetings

When the initial review of data and hardware failed to disclose an obvious source of the fire, a series of brainstorming meetings was held with participation by test engineers, design engineers, astronauts, etc. The purpose of these meetings was to initiate and critique possible fire initiation and propagation theories.

A large number of potential fire initiation and propagation theories were proposed and evaluation sheets were established to build up the supporting factors for the theory, negative factors to refute it, and to delineate additional physical examinations or tests required to support or to eliminate the theory. A total of 47 potential initiation theories have been proposed and evaluated. All of these are attached as Enclosure 18-55.

Of the 47 potential initiation theories, 46 are closed as not considered likely ignition sources, and one is closed as a probable potential ignition source.

The one probable ignition source is the DC wiring completely burned through in harnesses providing power to Environmental Control System instrumentation. Two potential initiation theories of a more general nature were also considered. These are described below.

#### a. Cold flow characteristics of Teflon insulated wire:

Teflon wire was selected for the spacecraft because of excellent resistance to high temperature, good dielectric properties, lightweight characteristics, etc.

It has, however, in common with other plastic materials, cold flow characteristics which permit the insulation to flow away from localized high pressure points over long periods of time. It is possible that localized high pressure points, either between wires or between a wire and structure, could ultimately result in breakdown of the insulation. All wire bundles in the spacecraft which showed damage were carefully inspected for signs of arcing. Only those locations delineated in other sections of this report showed such signs.

b. Failure of electrical connectors due to water/glycol spillage:

The characteristics of the inhibitor used in the coolant water/glycol fluid leaves a residue that is electrically conductive, hygroscopic, and flammable. Leaks of water/glycol occurred in the lower equipment bay and Environmental Control Unit area during earlier tests on S/C 012. These leaks were mopped up and connectors and accessible wire harnesses were washed with distilled water and alcohol, and dried with nitrogen.

After the accident, all connectors were carefully disconnected, photographed, and inspected for any signs of internal burning or arcing. No evidence of internal arcing or burning was found which indicated a fire source. A few isolated cases of pin arcing were found, but these appeared unrelated to the fire since all surfaces in the vicinity were clean and without any indication of a combustion path.

## 6. Data Indications

The purpose of this section is to summarize briefly the recorded data indications that were unusual and unexpected prior to the crew report of fire, and significant data indications following the crew report of fire.

### a. Gas Chromatograph Telemetry Indication

Gas chromatograph channel output variation occurred at 23:30:50 GMT. The gas chromatograph was not installed for this test and the connector that carries the telemetry data signals and the required AC power was placed on the gas chromatograph shelf prior to the test. Power to the AC line in the connector was turned on during the test, as required by the test procedure.

A careful examination of records showed activity on this channel seven times prior to 23:30:50 GMT.

Following is a summary of the seven periods of activity (see Enclosure 18-7):

- Trace A - 22:04:45 GMT - Gas Chromatograph (GC) trace changed in exact correlation with a rise in the VHF/FM RF output when transmitter was turned on. GC output change was 2 to 3 per cent.
- Trace B - 22:06:54 GMT - This trace correlates with middle gimbal angle stabilization loop, responding to fine align mode.
- Trace C - 22:19:23 GMT - This change in the gas chromatograph trace correlates to the Guidance and Navigation System (G&N) going to coarse alignment.
- Trace D - 22:20:09 GMT - Change correlates with G&N going to fine align. The large current drawn by this change in the G&N mode also caused transients on DC bus A and DC bus B.
- Trace E - 22:34:46 GMT - Pilot turned updata link to UHF.

Trace F - 22:53:13 GMT - Environmental Control System monitor reported high oxygen flow. He asked crew if the face plates were opened. Crew said "No." Much noise in background of Spacecraft.

Trace G - 22:55:40 GMT - Command Pilot changed cobra cable and was in process of communication check at this time. Location of Pilot was not known. Pilot did get cobra cable and may have still been in the lower equipment bay.

Trace H - 23:30:50 GMT - Variation just prior to the accident.

The telemetry data line in the connector has the characteristics of an antenna, and consequently can detect changes in the electromagnetic field within the spacecraft.

b. AC Bus 2 Voltage Variation

A momentary increase in AC bus 2 voltage was noted at approximately nine seconds before the crew report of fire, and at the same time the recorded parameters monitoring the equipment powered from AC bus 2 showed abnormal indications. Enclosure 18-3 shows the parameters and changes, with the times of sampling by the telemetry system. These were:

- (1) Rise in AC bus 2 voltage phases A, B and C
- (2) 1.7 second dropout of C-band decoder and transmitter outputs
- (3) Momentary dropout of VHF-FM carrier
- (4) Fluctuation of rotation controller null outputs
- (5) Gas chromatograph telemetry signal transient

Other equipment connected to AC bus 2 at this time had no telemetry monitoring capability that would detect effects of voltage variation.

The associated changes which occurred at the time of the AC bus variation are individually discussed:



(1) The C-band beacon parameters dropout occurred for approximately 1.7 seconds. The 1.7 second dropout observed is the minimum recovery time of the protective circuit internal to the beacon to prevent magnetron damage. Possible causes of the C-band beacon dropout are:

(a) Interruption of AC bus 2 power would cause the C-band beacon dropout as verified by special tests on a C-band beacon similar to the one used in S/C 012.

The test indicated that interruptions of the AC power, all three phases, or phases A and B, or phases B and C, for 10 milliseconds or more created a dropout.

(b) Momentary drop of range interrogation; however, the range C-band station log shows no report of interrogation dropout at this time.

The most probable cause of the beacon dropout was a momentary loss of AC input power to the beacon, particularly since the transponder dropout was coincident with the variation of the AC bus and the beacon performed normally after the recovery from the dropout until loss of the data.

(2) VHF-FM transmitter signal dropout occurred for approximately 30 milliseconds. A dropout of this nature has been duplicated by special tests conducted by Collins Radio Company with a transmitter under similar conditions. These tests show that the received video signal during the noted time can be matched very closely by a momentary dropout on the AC supply (all three phases) to less than 50 volts, or a dropout of DC supply to less than 6.5 volts for a period of 15 to 20 milliseconds. Since the VHF-FM transmitter recovered, as did the C-band beacon, the most likely cause of the dropout was a momentary interruption of the AC input power.

(3) Rotation controller null outputs showed momentary transients in each of the three control axes. The rotation controller outputs which were reading slightly off null just prior to the voltage variation (the controller was pinned) are supplied by phase A of AC bus 2. Special tests have shown that the null

output transients can be duplicated by a momentary interruption of AC bus 2 phase A input power.

(4) The gas chromatograph telemetry signal showed a sharp transient coincident with the voltage variation. The character of the transient is indicated in Enclosure 13-7.

The AC bus 2 voltage increase appeared on all three phases momentarily. The AC bus voltages are sampled ten times a second by the instrumentation system. It is, therefore, impossible to determine the actual variation of AC bus 2 voltages for 100 milliseconds prior to or after the observed voltage increase. In addition, special tests indicate that there is an inherent delay and stretching of the AC voltage signal conditioner output due to rectification and filtering. Consequently, an AC voltage transient occurred several milliseconds prior to the time indicated in the S/C 012 data. However, the AC bus voltages are connected to an overvoltage and undervoltage sensor which will trip if the voltage on any phase exceeds 135 volts AC or drops below 90 volts AC for  $32.5 \pm 7.5$  milliseconds. Main bus A and B voltages are also monitored by an undervoltage sensor which will trip if the voltage drops below 26 volts DC for  $70 \pm 30$  milliseconds. Any one of these conditions would cause a master alarm. The master alarm did not occur during the period of the AC bus 2 voltage variation.

#### c. High Oxygen Flow Rate

At 23:30:59 GMT the oxygen flow rate measurement went to a saturated condition of 1.03 pounds per hour. Fifteen seconds later the caution and warning system master alarm was triggered. The oxygen ( $O_2$ ) flow stayed in a saturated condition until loss of signal (LOS). Oxygen flow rate and associated data are shown in Enclosure 18-9.

There were 10 other periods during this test in which an unexplained saturated flow rate condition existed. A correlation of relevant data for these unexplained periods is shown in Enclosure 18-10. The actual flow rates for several of the times listed were computed using measured surge tank pressure.

Four possible conditions can cause a high oxygen flow indication. These are:

(1) H<sub>2</sub>O Cyclic Accumulator Activation - The cyclic accumulator is actuated every 10 minutes for a ten second duration by the Spacecraft Central Timing Equipment (CTE). The diaphragm pump is actuated when the CTE triggers the circuit. During the 10 seconds in which the solenoid is open, the O<sub>2</sub> flow transducer will saturate and energize circuitry which could trigger the Caution and Warning System high-O<sub>2</sub> flow indication; the system is, however, equipped with a 15 second time delay to prevent the 10 second high flow condition from triggering the system.

(2) Suit Leakage - Crew suits are not designed for the very low delta pressures that were present during this test. The joint seals, etc., are not adequately effective at low differential pressures and therefore crew movements can induce suit leakages which result in high-O<sub>2</sub> flow rates.

(3) Open Helmet Visor - Enclosure 18-12 shows that with an open helmet visor (23:19:13 GMT), Surge Tank Pressure responds within about 5 seconds. For this condition the surge tank pressure decayed from 739 to 480.6 psig (see Enclosure 13-13 which shows the history of surge tank pressure for the entire test). During the last high-O<sub>2</sub> flow condition the surge tank does not start decreasing for 12 seconds.

(4) Crew Movement - During five of the ten unexplained high oxygen flow rates, listed in Enclosure 13-10, the voice tapes indicate the crew was troubleshooting the communications problems. During the last three high-O<sub>2</sub> flow rates the Guidance and Navigation System gimbal angle movements have been correlated with crew motion and biomed data. Of particular interest is the time period of 23:24:03 to 23:24:06 GMT. Five seconds prior to start of high-O<sub>2</sub> flow the biomed data indicates a deep breath and possible talking by the Senior Pilot. Biomed data are available from the Senior Pilot only. The slope at the start of high-O<sub>2</sub> flow correlates with the characteristics of the data when the Command Pilot opened his face plate at 23:19:13 GMT. Another significant period is at 23:30:59 to LOS, where the middle gimbal torque motor input shows response to motion at 23:30:24 GMT. At this time the O<sub>2</sub> flow starts a gradual rise. At 23:30:39 GMT the gimbal torque motor inputs reflect a distinct vehicle motion. The biomed data from the Senior Pilot, shown in Enclosure 13-14, show the start of motion which is

also reflected in the continued increase of O<sub>2</sub> flow. At 23:30:59 GMT the O<sub>2</sub> flow rate reached saturation with motion still being indicated on the inner gimbal.

d. Live Microphone Condition

Voice tape analysis and instrumentation data records show that a live microphone constant-keying condition existed from the Command Pilot position during a considerable portion of the final test period.

The live microphone condition was evidenced in a real time during the test at 22:25:53 GMT, when the crew selected the VHF/AM T/R mode. Data analysis using the Merritt Island Launch Area Open-Loop Communication (MOLC) tape (S-band and VHF/AM voice) showed that the first indication of the live microphone was at 22:18:49 GMT.

However, a review of the Mission Control Center-KSC (MCC-K) tape showed that the MOLC tape recorder was stopped between 20:57:19 and 22:13:49 GMT. Further analysis of the MOLC tape established no evidence of the live microphone condition prior to 20:57:19 GMT. It is concluded therefore that the live microphone condition began between 20:57:19 and 22:13:49 GMT.

The crew became aware of the live microphone condition at 22:26:48 GMT, and started a series of troubleshooting exercises. These exercises, plus voice tape analyses and data records, indicated that the live microphone condition existed in the Command Pilot communication system. The known exercises were:

- (1) The Command Pilot switched from the "normal" connector to the "emergency" connector of his cobra cable.
- (2) The Command Pilot and Senior Pilot interchanged cobra cables.
- (3) The Command Pilot and Senior Pilot placed their cables back in the original configuration.
- (4) The Command Pilot replaced his cobra cable with a flight spare.
- (5) Various audio control panel modes were tried.

The live microphone condition continued to exist after the above exercises and was in evidence through the crew report of fire.

e. Crew Movement

Crew activity was evident for about the last 30-second period just before the crew report of fire. The data that indicates movement is shown in Enclosure 13-14 where several parameters support the indications. The crew was not required to perform any operation or function during this time. The Enclosure shows changes in the torquing voltage to the gimbal torque motors indicating significant spacecraft motion.

Activity of the Senior Pilot was interpreted from respiration rate, heart rate and phonocardiogram data. The Senior Pilot was essentially at a resting baseline until 23:30:21 GMT, when slight increases in pulse and respiratory rate was noted. At 23:30:30 GMT, there was a 4.5 second burst of noise on the electrocardiogram trace indicating some muscle activity. A similar burst occurs at 23:30:39 GMT accompanied by maximum noise on the phonocardiogram. The data are consistent with increased activity, but are not indicative of an alarm response. By 23:30:45 GMT all biomed parameters have begun to revert toward baseline levels.

The Command Pilot's live microphone condition on the S-band voice loop indicated considerable amounts of brushing and tapping-type noises during the 30 second time period prior to the crew report of fire. Noises on the S-band voice loop prior to this time were not of this magnitude or density.

Additional indication of crew activity was the onset of increasing oxygen flow to the suit circuits during this relative time span.

f. Cabin Pressure Rise

A determination of the pressure the cabin attained and the approximate time of structural rupture is included in this section. The analysis is based on observations from previous tests and certain known facts of the hardware design.

The installation of the optics system and INERTIAL MEASUREMENT unit on the navigation base is shown in

Enclosure 13-15. The navigation base is shock mounted on the Command Module structure. The optics system penetration through the pressure vessel is a set of bellows which forms the crew compartment seal. Navigation base displacement is most significant in the spacecraft pitch axis. The inertial reference and spacecraft axes are not coincident, therefore, gimbal angles must be transformed to reflect navigation base motion (refer to Enclosure 13-16).

A finer detail of the navigation base is shown in Enclosure 13-17. The single lower shock mount acts as a pivot point. The optics bellows mounted at the upper extreme end of the navigation base allows motion of the base about that pivot. A pressure differential across the optics and bellows assembly results in a force which will tend to rotate the upper end of the navigation base outboard. Any rotational motion or angular displacement of the navigation base will be reflected in the Inertial Measurement Unit (IMU) gimbal torque motor currents and gimbal angles. Deflection of the navigation base has been correlated with differential pressure across the optics and bellows assembly through data acquired during the altitude chamber test of S/C 012. The results are shown in Enclosure 13-18. With the cabin pressurized to 5.5 psig, the upper navigation base was deflected outboard. An approximate linear movement of the navigation base was noted as a function of decreasing cabin pressure.

Variations of temperature on the Command Module RCS "A" engine, CR 4561T, and on the Aft Heat Shield thermocouple, CA 5493T, are displayed in Enclosure 13-19 during the time of the accident. Cabin pressure and the three gimbal angles are also included for correlation. The variation of cabin pressure is shown from telemetry data which reached saturation at 21.3 psia. For comparison a second curve is shown which was developed from results of a digital simulation performed at AC Electronics, Milwaukee, Wisconsin, which determined the cabin pressure required to attain the gimbal angles observed during the accident.

The gimbal angles in Enclosure 13-19 change with the cabin pressure and reach an apparent maximum at 21:31:20 GMT, then reverse direction, indicating a decrease in cabin pressure. Because of the low sample rate of these measurements, the actual peak deflection and time of gimbal angle reversal is unknown. The RCS

thruster chamber temperature CR 4561T displays a sharp rise in temperature starting at 23:31:19.86 GMT. Assuming the sharp rise in temperature is the result of hot gas impingement, a rupture in the pressure vessel must have occurred prior to start of temperature rise because of the insulation surrounding the RCS thruster transducer and the response time of the transducer. Therefore, the rupture must have occurred between 23:31:18 and 23:31:19.86 GMT. The time of rupture was estimated at 23:31:19.4 GMT by Panel 10. The time of 23:31:18 GMT was the last gimbal angle data point prior to the sharp temperature rise at 23:31:19.86 GMT. Following the rupture, the cabin pressure would decrease allowing the navigation base to move toward its initial position. Results of a digital simulation indicate the cabin pressure reached at least 29 psia.

g. Suit Flow Dropout

At 23:31:09.62 GMT the suit flow rate of the Senior Pilot was at the upper limit of the transducer (saturated) of 25.27 lb/hr. The flow rate per man was actually higher and was approximately 64 lb/hr per man. One-tenth of a second later, at 23:31:09.72 the flow rate had dropped to the lower limit of the transducer (6.15 lb/hr) and stayed there until 23:31:11.82 GMT. It then returned to the upper limit at 23:31:11.92 GMT. The other two suit flow rates remained at the upper limit during this period (see Figure 18-18).

There are three possibilities that could explain the suit flow drop-off. These are:

- (1) A momentary short in the suit flow transducer wires would explain the suit flow transducer going to the lower limit and returning to saturated flow again. However, the suit delta pressure and compressor delta pressure show a marked change coincident with the drop in suit flow, indicating that the suit flow in fact changed.
- (2) If the suit outlet hose was disconnected, the suit outlet has a check valve in the suit which stops the flow to the suit giving an indication of no flow. The suit delta pressure and suit compressor delta pressure should increase and, in fact, did as shown in Enclosure 18-20. The decrease in these parameters within about 2 seconds after the increase can only be interpreted as suit burn-through

and/or subsequent reconnection of the outlet hose. Disconnection and reconnection of the outlet hose within a 2 second time period is highly unlikely. If this argument is to hold, the suit must have burned through to re-establish flow and sometime later the outlet hose was reconnected to the suit. The outlet hose was found connected after the accident, which tends to weaken the argument in light of possibility (3) which follows.

(3) The suit inlet hose was found disconnected from the Senior Pilot's suit. An explanation of this could be that the Senior Pilot disconnected his suit inlet for emergency egress.

h. Water/Glycol System Integrity

Pressure and temperature measurements in the water/glycol system were examined to determine if any line rupture or leak might have occurred prior to or during the early phase of the fire.

No indications of a leak were found. It should be recognized that very slight leakages (less than about 0.5 cubic inches) could not reliably be determined with the information available.



## 7. Data Analysis and Correlation

The purpose of this section is to treat each data indication prior to the crew report of fire in combination with engineering tests and analyses, and correlate with other available information to provide an integrated technical evaluation.

### a. Gas Chromatograph Data Interpretation

In the preceding section it was reported that the gas chromatograph measurement output varied seven times in the 22:00 to 23:00 GMT time period. It then remained totally quiescent for approximately 35 minutes, and at 23:30:50 GMT approximately 14 seconds prior to the crew report of fire, it again produced an output.

The last output is considered to have a special meaning with respect to the accident, because the trace was quiet for so long a period, and because an output occurred within seconds of the fire.

Tests were conducted at MSC and at the Contractor's facility to determine what physical phenomena can cause an output to be produced from a powered and open gas chromatograph electrical connector. Enclosure 18-21 shows the variations from two of these tests compared with the output from S/C 012. Trace A shows the output from a S/C 008 test at MSC, during the period of time when a plastic bag was being removed from the connector, where the wiring and connector were touched with bare hands. Trace C shows the output from a North American Aviation, Downey, California, test during the period of time when the wiring and the connector were subjected to an external flame. The composite data from all special test indicate that an output from the connector can be produced by the following:

- (1) Physical movement or disturbance of the wiring and/or the connector
- (2) Application of external heat to the wiring and/or the connector
- (3) Changes in the electro-magnetic field, affecting the antenna characteristics of the wiring and/or connector

Tests are being conducted in which a wire will be sparked with a gas chromatograph connector nearby to determine if any output can be produced.

b. AC Bus 2 Transient

The AC bus 2 over-voltage condition observed at approximately nine seconds before the crew report of fire is a characteristic inverter response attributable to one of the following conditions:

- (1) Momentary short or interruption of DC bus B input power to inverter 2
- (2) Momentary short on one or more phases of inverter 2 output
- (3) Removal of a major portion of the load from inverter 2

Enclosure 18-22 shows the basic AC and DC power distribution system configuration at the time of voltage variation. Power was in a standard configuration at the time.

Special tests have been conducted on S/C 008 at MSC and at the Contractor facilities to reproduce the telemetry voltage characteristic and the associated changes in C-band beacon, VHF-FM transmitter and rotation controller outputs. These tests show that the time relationship between the over-voltage indication and associated changes can only be duplicated by a momentary short or interruption of DC bus B input power to inverter 2. The results for all three conditions are shown in Enclosure 18-23. In this figure test AC bus 2 voltages versus time have been plotted with zero time as the time of VHF-FM transmitter and C-band beacon changes. The time that AC bus 2 voltages were sampled on S/C 012 is also indicated for each test condition. The data for the output of the AC bus 2 voltage signal conditioner was available only for the inverter DC input shorting test, but the plot of the bus voltages for the other conditions shows that the over-voltage occurs earlier and for a shorter time duration.

Voltage regulation tests were run on the ground power supply at Launch Complex 34. These tests were run under similar load conditions (30 amps) to that existing on DC bus B in S/C 012 at the time of the accident

Short circuits of 0.25 ohm resistance were applied across the bus for periods of 5 to 25 milliseconds. Measurements of voltage at the umbilical interface, voltage and current at the power supply were made using a CEC recorder with response characteristics good to 5000 cps. In addition, the ACE equipment was set up to monitor power supply voltage and current in a similar manner to that used for OCP FO-K-0021-1.

These tests indicated that a short circuit in the range of 5 to 25 milliseconds drawing approximately 75 amps caused an immediate drop in bus voltage of 13 to 15 volts, recovering to about 3.6 volts below steady state conditions after 1 to 1.5 milliseconds. The voltage remained constant until the short cleared at which time it overshoot steady state conditions by about 10 volts recovering to steady state by 1 to 1.5 milliseconds.

The ACE indications of voltage and current were sporadic, depending on the time of the short relative to the ACE sample time (sample rate 1 per second). Several current measurements were obtained for the 20 and 25 milliseconds duration shorts. These current indications were quite low, from 1 to 6 amps, apparently because of the transient response characteristics of the current measurement system.

It is concluded that the probable cause of the AC bus 2 transient and associated indications was a momentary short (2 to 25 milliseconds) of DC bus B affecting the input voltage to inverter 2.

c. High Oxygen Flow Rate

Telemetered data indicate that the high oxygen flow rate conditions for the last 30 seconds before the crew report of fire can be attributed to the apparent high level of prime crew suit leakage at low suit-to-cabin differential pressure, magnified by apparent crew activity. An analysis of S-band audio data also indicates that a face plate may have been open. An analysis was also conducted to determine if the high flow could be indicative of a sensor and/or associated wiring difficulty.

It was considered improbable that any short circuit between the signal lead and a 28 volt DC supply lead could occur.

Single failures could exist within the bridge circuitry controlling the flow sensor which would indicate high flow rates on both the PCM output and the signal to a high flow alarm relay. A preliminary examination disclosed shorts to ground in the flow sensor; shorts to ground will produce a zero or no flow output indication. It should also be noted that the location of the oxygen flow sensor was a high fire damage area, and that the sensor would be expected to be damaged by the fire.

Based on the above, it is concluded that the high oxygen flow data indication was valid, and that there was no malfunction of the sensor prior to the crew report of fire.

d. Command Pilot Live Microphone

The live microphone connotation means that the microphone amplifier in the audio center has received a ground, allowing 28 volts DC to energize the amplifier electronics, and the diode gates in the audio center on the S-band audio output have been grounded, allowing audio signals to modulate the S-band transmitter. These two conditions are normally effected by a crewman pressing his Push-to-Talk (PTT) button on the cobra cable, or in the Command Pilot's case, by pressing his translation controller PTT or his cobra cable PTT button. The PTT button, in addition to the above function, provides a ground for the VHF/AM Transmitter keying relay through the audio control panel VHF/AM T/R select switch. These VHF/AM T/R switches are connected together for all three astronaut positions which would cause a ground to be transferred among all positions in VHF/AM T/R mode. See Enclosure 18-24 for logic detail.

An analysis of this problem has isolated the cause to the PTT or keying line that runs between the cobra cable, translation controller, Command Pilot audio control panel, and the audio center (circuitry shown in Enclosure 18-24). The following has been determined:

- (1) The separate components have been checked for resistance to ground. All lines measured open which is correct.
- (2) The S/C wiring was checked and a 3000 ohm resistance was measured to ground. This 3000 ohm resistance could account for the keyed microphone. However, this resistance could be a result of the fire damage to

wire bundles. Later, when an attempt was made to locate the cause of the 3000 ohm resistance, a recheck did not produce the same results. The circuit now measures open, which is normal.

(3) The translation controller PTT button was pushed and released ten times. On the fifth try the button stuck down. If the button had stuck during the S/C 012 test the microphone would remain keyed.

The audio center has successfully completed qualification testing with this line grounded for twenty-eight days.

A review of switch positions in the Command Pilot audio control panel indicates that all switches were in the positions expected. When in this configuration, current drawn by the keying line is limited to 20 milliamps at 28 volts. Tests run with a cobra cable show that no sparks were generated with 28 volts and 150 milliamps.

Based on all of the above, it is concluded that the live microphone condition was probably not a source of ignition.

e. Crew Movement

Crew movement was indicated during the last minute preceding the crew report of fire, most prominently by the torquing voltage to the gimbal torque motors. An attempt was made to determine what type of activity by the crew could produce these torquing signals by reviewing all available data from previous tests with the proper guidance mode selected. There was no consistency in the effects of crew activity such that repeatability could be shown for presumably similar activities. This may be expected since the combination of crew actions for a particular operation may never be the same. Similarly, the vigor with which an action is performed can vary. Even though the crew activity cannot be defined, the fact remains, crew motion can be detected.

f. Analysis of Tape Recorded Transmissions

The voice transmissions shown in Enclosure 18-5 were analyzed with the use of MOLC RF voice recorder tapes, oscillographs of the MOLC tapes and PCM data. This

enclosure shows the VHF/AM and S-band voice tracks oscillograph readout from 23:29:42.5 GMT to LOS.

(1) 23:29:42.5 to 23:30:14 GMT

(a) The Command Pilot was transmitting on S-band. The Senior Pilot made a voice transmission on S-band and VHF/AM. There was no voice transmission by the Pilot.

(b) The ground personnel were transmitting to the S/C on S-band. The voice of the Command Pilot was being turned around by the CAST (Astro Communicator Console) system and re-transmitted to the S/C on VHF.

(c) The live microphone noises were not evident, probably because of the higher noise level caused by the uplink S-band being patched to the MOLC RF recorder.

(2) 23:30:14 to 23:31:00 GMT

(a) There were no voice transmissions from the S/C.

(b) The ground personnel were not transmitting to the S/C on VHF.

(c) There was no change in the live microphone condition. Considerable amounts of noise similar to those obtained when a microphone is brushed or tapped, including breathing sounds, were evident. Some of the louder noises appear to have had sufficient amplitude to trigger the uplink VHF/AM via CAST.

(d) There is evidence of an open visor.

(3) 23:31:00 GMT to LOS

(a) There were two series of voice transmissions on S-band. The times for these two transmissions are detailed in Enclosure 18-5. No voice communications on VHF were made from the S/C during this time period.

(b) The ground personnel were not transmitting to the S/C on VHF. The voice transmissions

from the S/C were being turned around by the CAST system and were retransmitted to the S/C on VHF.

(4) Analysis of Voice Tapes During the Period of Fire

The tape transcripts of the voice tapes from the C/M during the time period of the fire (referred to as the first and second transmission, on Enclosure 18-6), have been extensively analyzed. This analysis included a review of all transmissions prior to the fire that were made by the crew during the test in an attempt to aid in the determination of who made these last two transmissions and what was said. This analysis was made by NASA personnel familiar with the communication systems, the crew and their voice characteristics, the sequence of events before, during and after the fire as determined during the accident investigation. Experts at the Bell Telephone Laboratories performed extensive analysis of the tape record. The Board also reviewed these transmissions. Review by other experts is currently in progress. Any new findings from these additional reviews will be included in Appendix G of the Final Report.

Except for a portion of the first transmission, which is quite clear, it is impossible to define exactly what was said by the crew. Two points made by the Bell Telephone Laboratory experts, however, should be noted:

(a) The present state-of-the-art of analyses of voice records is such that little, if anything, can be determined as to what was said if the recording is not sufficiently clear to be intelligible by listening alone. Analyses under these circumstances can provide some clues to determine which crew member initiated the transmission. These clues cannot however establish definite identity.

(b) When the recording of the transmission is not clear, there will be nearly as many interpretations of what was said as there are qualified listeners. Many interpretations of what was said have been made. A summary of these interpretations is made in the following paragraphs.

The analysis of the first voice transmitted is as follows:

This transmission began at 23:31:04.7 GMT with an exclamatory remark. This transmission is not clear. Most listeners believe this initial remark was one of the following:

"Hey"

"Fire"

"Break"

Most listeners believe, and laboratory analysis supports this belief, that this transmission was made by the Command Pilot. This remark is followed by a short period of noise (bumping sounds, etc.).

The second portion of this first transmission begins at 23:31:06.2 GMT with an unclear word. Most listeners believe the first to be one of the following:

"I've"

"We're"

The remainder of this transmission is quite clear and is: "...Got a fire in the cockpit", followed by a clipped word sounding like "vheh", which ended at 23:31:10 GMT. Many listeners believed this transmission to have been made by the Pilot. Some believe it could have been made by the Command Pilot or the Senior Pilot. However, laboratory analyses indicate the greatest probability that it was made by the Pilot, but the results of the analyses do not negate the possibility that one of the other crew members could have made the transmission.

The analysis of the second voice transmission is as follows:

Following a 6.8 second period of no transmission, the second transmission began at 23:31:16.8 GMT and ended at 23:31:21.8 GMT.



The entire second transmission is somewhat garbled. This second transmission, therefore, is subject to wide variation of interpretation as to content and as to who was making the transmission or transmissions. The general content is what appears to be three separate phrases and it has been interpreted several ways by many listeners. The following is a list of some of the interpretations that have been made:

1. "They're fighting a bad fire - Let's get out....Open'er up."
2. "We've got a bad fire - Let's get out .... We're burning up."
3. "I'm reporting a bad fire....I'm getting out....Oh, aah."

Many listeners believe this transmission was made by the Pilot. It should be noted that:

- a. The total time duration of these two transmissions was brief, lasting 17.1 seconds; the first lasted 5.3 seconds and the second lasted 5.0 seconds, with a 6.8 second period of no transmission between.
- b. The transmissions provide evidence only of the time the crew first transmitted a report of the existence of the fire and do not provide any direct information as to the cause of the fire.

Two analyses of tape recorded transmissions were completed. The detailed findings are contained in references to this document. The first, Reference 18-8, is a report prepared by Bell Telephone Laboratories. The second, Reference 18-9, is a report prepared by NASA MSC.

#### g. Related Tests and Analyses

The purpose of this section is to cover special tests, analyses, additional data and other information that is essential to complete the investigation of the accident.

A brief summary of significant special test results is attached as Enclosure 18-56.

(1) Onboard Records Analysis

Items of onboard procedures, log books, switch lists, etc. found in S/C 012 after the accident were delivered to the Federal Bureau of Investigation for reconstruction and spectrographic examination. All of the items have been positively identified. Written remarks were either changes to the OCP switching lists or crew comments in the crew log books. None of the comments are significant with respect to the accident and no other information was found pertinent to the cause of the fire.

(2) Status of Inverter 2 Investigation

Inverter 2 (Part No. ME 495-0001-0004, serial No. 88) was returned to Westinghouse facility in Lima, Ohio, for investigation relating to the S/C 012 accident.

The results of the initial electrical tests conducted on the inverter disclosed that a pair of transistors in the booster stage was shorted and a fuse was open. The other four transistors in the inverter's booster stage were removed and checked out satisfactorily. The good transistors and new replacements were reinstalled. The inverter was again electrically checked and operated satisfactorily. Replacement of the fuse was not required for this check.

It is concluded that the inverter was not the source of the fire and that the transistors failure was due to thermal stresses induced by high temperatures external to the inverter. The fuse was probably damaged during the effort to remove the foam in order to gain access to the internal test points. It is also concluded that the inverter could not have caused the AC bus 2 transient at 23:30:54:86 GMT for had the transistors failed at that time the inverter would have dropped out and stayed out.

(3) Status of ECS Parts and Assemblies Investigation

The Screening Committee Report listed 54 Environmental Control System parts and assemblies as possible ignition sources. Further investigative work has placed 52 of these into the improbable ignition source

category. The two remaining suspect items are still being analyzed and are identified as follows:

Electrical Cable Assembly P/N 836599-1-1  
Electrical Cable Assembly P/N 836602-1-1

The two cables assemblies are connected in series. Both carry DC power to an instrumentation temperature sensor power supply. The power supply then provides power to five signal amplifiers.

Both DC bus A and DC bus B power wires were contained in these cables and both were protected by 5 amp circuit breakers. The circuit breakers were found open after the accident. Anomalies were not observed on the data from the five measurements. A short in one of the above cables would not show an anomaly on the data since the redundant power would continue to supply power necessary to maintain the integrity of the measurements.

Post-fire tests did establish a grounded condition in both harnesses and visual inspection revealed that a considerable amount of one of the cables was completely consumed by fire. These harnesses are covered in more detail in section 8-A of this report.

## 8. Technical Discussion of Possible Ignition Sources

The specific cause or the trigger that initiated the fire in S/C 012 has not been determined. A number of potential causes have been identified and actions have been implemented to validate each one, so as to determine which will remain as likely possibilities.

The family of possible sources of ignition that apply to the Command Module includes:

- (a) Spacecraft electrical power
- (b) Overheating of mechanical equipment
- (c) Electrostatic spark discharges
- (d) Spontaneous combustion

The most likely cause of ignition is in the Spacecraft Electrical Power System. This may provide an ignition source from electric arcs that can be produced by making or breaking electric circuits, or by physical failure of a current-carrying wire. This most likely supposition is supported by the fact that the AC bus 2 power system exhibited a transient ten seconds prior to the crew report of fire, indicating an electrical power abnormality just prior to any awareness of fire by the crew.

Spontaneous combustion has been considered extensive series of test involving all known combustible materials in the spacecraft in combination with all known contaminants has been completed. The spontaneous ignition temperatures of these materials were all found to be in excess of the maximum test temperature of 400°F. All areas in the S/C should be well below this temperature unless there is a malfunction or electrical short. Therefore, the possibility of spontaneous combustion is ruled out.

Chemicals that are highly reactive can produce sufficient heat to start a fire. There are two sources of highly reactive chemicals in the spacecraft. These are the batteries and the lithium hydroxide for the Environmental Control System. Analysis of data and post-fire examination of these objects indicates that they were probably not involved in the start of the fire.

Electrostatic discharge from one of the suits to adjacent material, initiating a fire in Velcro pile or other easily combustible material, has been considered a source. Tests conducted in S/C 014 indicate that insufficient energy is generated for ignition to occur, (refer to Panel 8 Report).

The probable cause of ignition follows:

a. DC Wiring for Environmental Control System  
Instrumentation Burned Through

Three separate harnesses providing DC power for Environmental Control System instrumentation have been found burned through. Two of these harnesses are shown in Enclosure 18-25 as they appeared before the accident. The harness lying over the Waste Management System bare stainless steel line contained both DC bus A and DC bus B power wires. The harness lying on the floor under the plumbing contained DC bus B power wires only. The total complement and identification of all wires in each of these two harnesses is shown in Enclosure 18-26.

The third harness that was burned through provided DC bus A and DC bus B power for an instrumentation sensor power supply. The power supply then provided power to five signal amplifiers. The harness that mates with this harness at an electrical panel near the ECU also is suspect at this time. The total complement and identification of all wires in each of these two harnesses (both similar because connected in series) is described below:

- (1) Twenty-three wires total
- (2) All wires were 24 gauge
- (3) Wires were identified as:

28 volt DC bus A and bus B power leads (2 wires)  
28 volt DC return (1 wire)  
5.4 volt DC, power supply output (5 wires)  
18 volt DC, power supply output (5 wires)  
-0.5 volt DC, power supply output (5 wires)  
common returns, power supply output (5 wires)

Enclosure 18-27 illustrates the nature of the installation of two of the harnesses on S/C 014. The lower edge of the aluminum access door to the lithium hydroxide holders contacts one of the harness when the door is opened and closed. It is inferred that the installation in S/C 012 was similar to that in S/C 014. Enclosure 18-28 shows the remains of these two harnesses after the accident. Sections six to twelve inches in length of each harness are missing. If a short occurred in either of the harnesses, the evidence is gone. In this same enclosure, the third harness that was burned through is shown. This third harness is located within a one inch radius of the center of the photograph, connected to the lower electrical connector on the panel shown at the left.

Splices were made at KSC in the wires of the harness lying over the steel line in the DC bus B power and return wires on September 12, 1966. These splices were made in the wires about four inches away from the point at which the harness ran over the line. The splices are still contained in the harnesses. They have been examined, and all are in a satisfactory condition.

Debris netting lay over the harnesses traversing the complete left side of the Command Module at the floor. If a short did occur in these harnesses, ignition and fire propagation could take place.

The harness lying over the line contained instrumentation power for two measurements, Oxygen Flow Rate and Oxygen Regulator Outlet Pressure. DC bus A and bus B 28 volt power was provided to each instrumentation sensor. Twenty-two gauge wires were used throughout this harness. Two 5 amp circuit breakers were provided for these circuits. Bus B power for both sensors was protected by one breaker, and bus A power by the second breaker. Both circuit breakers were found in an open condition after the accident. Both measurements provided proper output signals until the loss of all data, some 17 seconds after the crew report of fire.

The harness lying under the plumbing contained instrumentation power for the CO<sub>2</sub> Absorber Outlet Temperature. It also carried power to a discontinued measurement. DC bus B 28 volt power was provided for both measurement circuits. Twenty gauge wire was used for all power circuits in this harness. Each circuit was protected by a 1/4 amp fuse. Both fuses were found in a blown condition following the accident. Since the one active measurement circuit provided proper output signals until the loss of all data, some 17 seconds after the crew report of fire, it is concluded that the fuse for this circuit did not blow until after this time. Because no data exists from the discontinued measurement, it cannot be concluded when this fuse blew.

The third and fourth harnesses at the electrical panel contained power for five temperature measurements. Two 5 amp circuit breakers were provided for these circuits; bus B power was protected by one breaker, and bus A power by the second breaker. Both circuit breakers were found in an open condition after the accident. All five measurements provided proper output signals until the loss of all data some 17 seconds after the crew report of fire.

A momentary shorting condition could have occurred in any of the power wires in any of these harnesses without being seen in the telemetered data and without affecting the measurement circuits.

Indications of copper have been found on the bottom of the lithium hydroxide access door. Indications of copper and pit marks have also been found on the stainless steel line over which one of the harnesses lay. The stainless steel line has been examined in the Metallurgical Laboratory at KSC and it has been determined that there are no pit marks indicative of arcing. Two modes of copper deposits were evident. One was apparently caused by molten copper dropping onto a heated line resulting in alloying and diffusion between the copper and stainless steel elements. The other was due to dropping of molten copper onto a relatively cool stainless steel line indicated by molecular diffusion at the bead-tube interface.

It has been determined that the harness containing DC bus B power wires protected by fuses was probably not the fire initiator, as current flow is very limited prior to the fuses blowing. The other three harnesses, each containing both DC bus A and DC bus B power wires, remain as probable causes of ignition.

## 9. Technical Discussion of Other Suspicious Wiring

A physical examination of wiring and equipment for arcs, shorted and suspicious wiring has disclosed ten specific items, as mentioned in section C-2 of this report. The first was covered in the preceding section as the probable cause of ignition. The remaining nine are not considered probable ignition sources, and each one is discussed in this section.

### a. Arc Between a DC Wire and the Cover of J-Box C15-1A52

An arced point was discovered between a wire in a bundle and a metal cover at the lower left corner of the lower equipment bay just to the left inverter 3. The installed cover is illustrated in Enclosure 18-29. The back side of the cover showing the arced point on the cover and the wire is illustrated in Enclosure 18-30.

It was determined that the arc occurred between a wire in the Reaction Control System/Stabilization Control System (RCS/SCS) and the cover protecting the C15-1A52 J-Box. The wiring was traced to a circuit from DC bus A, a 16 gauge wire, protected by a 20 amp circuit breaker. The wire supplied 28 volt DC power to the RCS plus-yaw engine solenoids. The circuit breaker was not opened by the short circuit.

Enclosures 18-31 and 18-32 illustrate the arced point on the cover and the wire magnified many times.

An arc was produced in this bundle when a technician was removing J-Box C15-1A52 on January 17, 1967, and the wire was repaired. The wire which arced against the cover at the time of the accident is a different wire in the same bundle. The wire harness installation had obscured access to two cover plate mounting bracket screws. This was corrected on January 19, 1967, by separating the harness into two bundles for a short distance. With this slight relocation, one of the bundles was adjacent to a portion of the cover not protected by a nylon grommet edging. This is also illustrated by Enclosure 18-30.

An additional interesting point for this cause possibility is that the gas chromatograph wiring harness and the bus B 28 volt DC power harness for the biomed recorder, which might be associated with pre-accident data variations, are attached to the harness that contained the arced wire.



Supporting factors for this ignition cause possibility include the definite evidence of an arc, previous water/glycol spillage in the general area three months before, the flammability of the adhesive for the nylon grommet edging, and the proximity of debris trap netting.

Negative factors include the preventative washing and drying of the wire bundles in the area after the water/glycol spillage and the lack of any telemetry transient indication on that function prior to the crew report of fire. A measurement sampled 200 times per second, which would show a drop below approximately 10 volts, shows no change until shortly after the pressure shell rupture, at which time some evidence of a short is indicated.

Preliminary tests have been conducted on the flammability characteristics of water/glycol and the water/glycol inhibitor at Kennedy Space Center (KSC), Manned Spacecraft Center (MSC), and Raychem Corporation, Redwood City, California. These tests support the possibility of a fire propagation path along wiring that has been exposed to water/glycol spillage or leakage.

A test was conducted at MSC on a simulated cover plate with adjacent flammable materials configured as in S/C 012 with the same oxygen/pressure environment. When the adhesive/nylon grommet edging was ignited with a nichrome wire at the arced point, there was a fire propagation along the adhesive/nylon grommet edging spreading above to the Velcro on the flight qual recorder and to the left to the debris netting in the lower left-hand equipment bay corner.

A test was conducted on a duplicate cover plate at KSC to determine if an electrical arc would ignite the adhesive/nylon grommet edging in the oxygen/pressure environment as existed in S/C 012 at the time of the accident. During this test, ignition from an arc did occur, the fire progressed faster along the adhesive than along the nylon edging, and a section of debris netting on the opposite end of the nylon edging ignited in approximately 9 seconds.

In all tests of flammability of adhesive/nylon grommet edging combinations conducted to date, there was a complete burning of the nylon grommet edging material to the point where it was indistinguishable after the fire. A review of Enclosure 18-30 shows clearly

that all of the nylon material in S/C 012 did not burn, but that a decomposition took place. A test applying external flame to the front face of the panel more closely duplicates the melting characteristic of the nylon edging as illustrated in the same photograph. This test indicates that if this arc was the ignition source, then the fire propagation path would not be along the adhesive/nylon grommet edging; the fire propagation path would thus be inferred to be along wiring that had previously been exposed to water/glycol.

A hardness analysis conducted on the aluminum cover disclosed that the left edge was exposed to much higher temperatures than the right edge. The cover was fabricated from 2024-T6 aluminum alloy. The extreme left edge was in a T3 aged condition, while the right edge was in the original T6 condition. The left edge was, therefore, subjected to a temperature in the range of 800 to 885 degrees Fahrenheit. A physical examination also disclosed that the fire progressed from the left side to the right side of the panel cover.

The Velcro on the "flight-qual" recorder panel does not appear to have sufficient fire damage to indicate that the fire was initiated at this point. A hardness and conductivity analysis was performed on this panel. The analysis disclosed that all areas of the panel were exposed to the same level of external heating.

A simulated flight-qual recorder panel used during a special fire propagation test conducted at MSC was sent to KSC for comparison with the S/C 012 panel. It was determined that this panel was of a lighter gauge, and that the Velcro was applied with a different adhesive. The MSC results are therefore considered inconclusive.

Special tests were conducted at KSC in an oxygen/pressure environment to determine the current required to produce a similar arc on a wire and cover as that evident from S/C 012 hardware. A test conducted on March 28, 1967, disclosed that the nylon edging/adhesive combination was ignited when an arc was produced approximately 1-1/2 inches away.

It is highly probable that the nylon edging/adhesive combination would be totally burned away if this arc was the initiator of the fire.

b. Shorted Gas Chromatograph AC Wiring

The gas chromatograph was not installed on S/C 012 at the time of the accident. The gas chromatograph connector was placed on the shelf of the gas chromatograph (GC) compartment. The connector was not bagged, and AC bus 1 phase A power was applied to the connector through a closed circuit breaker. Twenty-two gauge wire was used, protected by a 2 amp circuit breaker. The circuit breaker for the GC was found to be open following the accident, with a heavily sooted condition. It cannot be determined when the circuit breaker opened. The harness was not tied down in a flight configuration because the GC was not installed.

Two physical peculiarities were noted concerning the GC wiring and the connector. After the accident, the harness and connector were found on the floor. This is illustrated by Enclosure 18-33. It should be noted that the GC connector lay on a big harness. Enclosure 18-35 shows two spot ties that were unblackened as a result of being protected by the GC connector. Enclosure 18-35 shows the side of the connector that lay against the big harness and protected the two spot ties. This side appears burned and the potting at the back of the connector is melted. The GC connector was stuck to the big harness and had to be pried loose with a tool. It is concluded that the connector was burning in a different location, but fell or otherwise moved to its final location prior to the time the fire swept across that portion of the floor. It can also be concluded that the connector either protruded beyond the GC compartment shelf and was burned in that location, or that it was burned while it lay inside the gas chromatograph compartment before it fell to the floor.

Secondly, the two GC AC wires exhibited peculiar melting characteristics. The output signal leads from the connector were fed through a fiberglass sleeve. One hundred fifteen volt AC power was carried to the connector through a twisted pair of Teflon-insulated conductors. These power conducting wires were run along the signal leads and were occasionally tied together. The power wires show a number of copper balls attached to their surfaces. This condition is illustrated in Enclosures 18-36 and 18-37.

All attempts to simulate this condition by either short circuits or by application of external heat have not resulted in a similar appearance of the AC wires. It is concluded that the beading was caused by localized

external heating, with Teflon insulation degradation followed by shorting of the wires, causing molten copper to flow through defects in the wire nickel plating. It has been estimated that the external heat to produce this condition was in the order of 2500<sup>o</sup>F for less than one second. It is inferred that this condition resulted as the harness fell through the flame to the floor.

X-rays and continuity tests of the connector pins and input wiring showed no evidence of arcs or short circuits. For this reason, this is not a suspect fire initiator.

c. Shorted DC Wires to Scientific Equipment Bay 2

Wires providing DC bus B power to scientific equipment were found to be shorted. These are 22 gauge wires protected by a 20 amp circuit breaker. The circuit breaker was found to be open following the accident and to be in a heavily sooted condition. The scientific equipment was not installed, therefore, no information is available as to when the circuit breaker was opened.

The wires that are shorted are located at the edge of a compartment shelf directly over the entry batteries. The location of the wires is illustrated in Enclosure 18-38.

The pattern of battery swelling and the scorching of the batteries indicates that they were exposed to a source of considerable heat centered at the face of Battery B, and that very high heat flow occurred in front of and in the spaces between the three batteries.

Tape was applied to protect the battery terminals during this test. The spots of scorched residue on the batteries was determined to be similar in all respects to the tape. The burning of this tape could have burned the wiring insulation off, and thereby caused the shorted condition.

Enclosure 18-39 illustrates the shorted wires projecting beyond the shelf. It is concluded that these wires shorted as a result of the fire from the floor (the same heat source that affected the batteries). Tests in the Metallurgical Laboratory at KSC have substantiated that the shorting was the result of external heat.

d. Cabin Air Fan 1 AC Wiring Shorted

The cabin air fan 1 circuit breakers for phases A and C were found to be open after the fire, and electrical tests of the fan circuitry in the spacecraft indicated shorted phases. Cabin air fan 2 was in a satisfactory condition. Cabin air fan 1 is powered by AC bus 1 and fan 2 by AC bus 2. Twenty-two gauge wires are used and each phase is protected by a 2 amp circuit breaker. The circuit breaker for AC bus 1 phase A was found with a very light-sooted condition, and the AC bus 1 phase C circuit breaker was found with a sooted condition.

Enclosure 18-40 shows the location of the cabin fans. They are located on the Command Pilot side of the Command Module. It is not known whether the short circuit occurred before or after initiation of the fire. However, because there is a lack of fire propagation material, it is inferred that the shorting occurred as a result of the fire. A physical inspection of the fan and the fan area for fire damage does not indicate this to be a fire initiation area. Enclosure 18-41 shows the conditions of the fans following the accident.

An inspection of the fans after removal from the S/C shows that both rotors were frozen as a result of melting of epoxy on the stators. No shorted condition has been found in fan 1. The electrical harness was examined and insulation was found burned off in one area. The electrical harness is being checked to verify that the damage was an effect and not a cause of the fire.

e. Crushed DC Instrumentation Harness in Environmental Control Unit

A wire harness for the Compressor Differential Pressure and Glycol Accumulator Quantity instrumentation transducers has been found in a crushed condition. This is an Environmental Control Unit harness that was crushed between a lithium hydroxide canister and the cyclic accumulator control during the assembly process. The harness contained ten 24 gauge wires, and contained both DC bus A and DC bus B power.

The circuit breakers for these circuits were found closed following the accident. The sleeving is intact and does not indicate any ruptures. For these reasons the harness is not considered an initiating source of the fire.

f. Shorted DC Wires Providing Power to the Biomed Recorder

Short circuits have been found on the octopus cable near connector J185. This connector is located directly above the gas chromatograph compartments, and is illustrated in Enclosure 18-42. This wiring has been identified as 28 volts DC bus B power for the biomed Medical Data Acquisition System (MDAS) recorder. Twenty-two gauge wires were used, protected by a 20 amp circuit breaker. The circuit breaker was found to be open following the accident, with a heavily sooted condition. The MDAS recorder provided satisfactory data until after pressure shell rupture, therefore, the circuit breaker opened after this time. The octopus cable was not in a flight configuration as the connectors were not potted.

Enclosures 18-43 shows a closeup of the connector, and Enclosure 18-44 illustrates the shorted condition of the DC wires.

Enclosure 18-45 illustrates the layout of the power wiring to the J185 connector. This wiring runs down a channel alongside the right edge of the chromatograph compartment, then along the edge of the floor of the chromatograph compartment, then down to the floor along the left edge of inverter 3. At the floor, it is tied to the same harness that shows the presence of an arc with the cover of J-Box C15-1A52. This power wiring to the J185 connector is also adjacent to the gas chromatograph harness at all locations from the arced point to the channel entry point. This harness and the gas chromatograph harness were tied together but were not tied down in a flight condition; they were laid up against the gas chromatograph compartment. Both harnesses were found on the floor after the accident.

In addition to the shorted condition on the octopus cable between the J185 connector and MDAS recorder, the DC wires are also shorted at a point near the left end of the gas chromatograph compartment floor. The shorted condition at this location does have a bubbled copper appearance, similar to that noted on the gas chromatograph AC wires.

Preliminary examination of both sets of harnesses have been made in the Metallurgical Laboratory at KSC. The shorting on the octopus cable was found to be superficial and the result of fire damage. The DC power harness to the J185 connector, because of the similar appearance to the gas chromatograph wires, was also the result of fire damage; it is concluded that the harness was subjected to both a short and to external heating from the fire.

g. Shorted AC Wires Providing Power for Suit Compressor 2

Wiring in the four conductor wire harness to suit compressor 2 appeared shorted, with suspected evidence of arcing.

AC power to each of two suit compressors is provided by 24 gauge wires. Each phase for each suit compressor is protected by a 2 amp circuit breaker. The harness for each compressor can provide either AC bus 1 or AC bus 2 power, dependent on the switch position selected by the Pilot.

The switch position following the accident shows that the suit compressor switch was in the compressor 1, AC bus 1 position. The circuit breakers for phases A and B for compressor 1 were found open with heavy soot on the breaker stems. Telemetry data indicates that a compressor was operating until loss of data; therefore the circuit breakers opened after this time.

Enclosure 18-46 illustrates the location of the wiring and suit compressors in the Environmental Control Unit on Spacecraft 012 after the accident.

Suit compressor 2 was not to be operated during the test. A re-examination of the harness disclosed that the connectors for compressors 1 and 2 were reversed from the expected interconnect. With the connectors being reversed, compressor 2 would then have power and the wires could short, and the compressor 1 circuit breakers would open when the shorting would occur. Enclosure 18-47 illustrates the harness for compressors 1 and 2. The connector for compressor 1 was disconnected, and the wires were cut at the connector for compressor 2. Note the metal band with the number "2" for the wires providing power for compressor 1.

A closer examination of the wires disclosed that the shorted appearance was the result of fire damage.

h. Command Pilot Suit Wiring Shorted

Short circuit damage has been found in the Command Pilot's suit wiring. No shorts were noted either in the Senior Pilot or Pilot suit wiring.

Four shorted wires were found in the communications wiring between the suit connector and the helmet communications connector. The wire insulation was discovered to be brittle, discolored and cracked. The wires were identified as microphone signal, microphone signal return, earphone signal and earphone return. Enclosures 18-48 and 18-49 illustrate the shorted condition of the wires.

An intermittent condition was also noted in the 16.8 volt DC biomed power wire in the torso harness between the suit connector and the biomed connector. This condition is considered to be not relevant to the cause of the accident, in that no biomed power was being supplied to the Command Pilot's suit.

The vendors of the torso harness materials have provided the following information:

- (1) The nylon sock around the ribbon cable melts at 480 degrees Fahrenheit.
- (2) The silicone, of which the ribbon is made, melts at 600 degrees Fahrenheit.
- (3) The Milene insulation around the wires cracks at 430 degrees Fahrenheit and melts at 480 degrees Fahrenheit.

From the above information, it is probable that the exterior of the ribbon cable around the area of the damaged wiring was subjected to localized and superficial heat. This would cause damage to the internal wiring insulation without damaging the silicone ribbon.

i. Arc on Structure by Side of Switch S11 in Back of Panel 8

On removal of panel 8 from S/C 012 it was observed that there was an area of damaged conformal coating on wire terminal 2 of switch S11. Continuity checks showed that a potential short existed from the wiring through the damaged conformal coating to the substructure behind the panel. Supplemental examination of the substructure



was made to determine the extent of any arcing from panel 8 switch S11 to the substructure. Minute arc pits were found in the substructure which indicate that low power arcing did occur, and could more properly be described as sparking. The lack of silicone dioxide deposits indicates that the temperature generated by the arcing was not high enough to cause significant deterioration of the silicone rubber conformal coating material.

The panel and switch location and substructure appearance is illustrated in Enclosures 18-50 and 18-51. Switch S11 serves as an enable function for Service Module Quads A and C Roll. The wire terminal in the area of damaged conformal coating carried DC bus B power. An analysis of circuit conditions disclosed that this circuit was not powered before or during the fire. It was determined that the switch was in the "OFF" position before and after the fire. Continuity checks have been performed to confirm that the switch was wired properly. Refer to Enclosure 18-41 for a schematic description of switch wiring.

Examination of the wire terminal and pit on the bracket are inconclusive as to existence of an arc and indicate that the observed damage most likely occurred from a mechanical abrasion while the panel was being installed. From the appearance of the area surrounding the pit on the bracket, and the contact area on the wire terminal, it is deduced that any possible sparking generated by the short circuit current was confined under the conformal coating.

From the above it is concluded that, while an arc or short circuit current may have occurred in the contact area of S11 wire terminal and bracket V16-335126-85, this circuit was not energized during this test, and this condition must have resulted from a prior test. Further the evidence indicates that the potential current level through any such fault would have been so low that it would not have caused any significant disturbance on the power bus.

## 10. Technical Summary

For the last few minutes of the test all recorded test data indicated that all systems were operating satisfactorily with no indication of any malfunctions, with one exception - the communication system. Communications were poor between the ground and the Spacecraft and a live microphone condition was present in the Command Pilot voice loop.

The cause of the live microphone has been attributed to picking up a ground somewhere in the Command Pilot Push-to-Talk circuit in the Spacecraft. The specific source of the ground has not been established. This malfunction, electrical in nature, is not considered to be a fire initiation source.

The overall inputs and outputs of Spacecraft systems were measured and recorded. There is no reason to believe that possible malfunction or abnormality would have been indicated had more detailed measurements been obtained from each system.

For approximately the last thirty seconds prior to the crew report of fire many measurements reflect crew motion in the Spacecraft. There is no way in which crew activity can be derived from these measurements.

An electrical power system abnormality was indicated at approximately ten seconds prior to the crew report of fire. This electrical abnormality occurred in the AC bus 2 power portion of the system. All AC bus 2 voltage measurements were affected. The data from equipment powered by AC bus 2 shows that they were also affected. The composite of these data and special tests conducted after the accident point to the conclusion that the AC bus 2 problem was caused by a momentary loss of inverter 2 output.

The momentary loss of inverter 2 output should not be implied to constitute an inverter failure. The inverter was returned to the supplier for teardown and analysis to positively establish whether it could or could not have malfunctioned in a manner reflected by the data. This has been completed and it has been concluded that the inverter did not cause the AC bus 2 dropout, and that it was not the cause of the fire.

It is believed that the momentary loss of output to inverter 2 was caused by an interruption in the DC power being supplied to inverter 2. This DC power was being supplied from DC main bus B. The most likely cause of an

interruption in DC bus B power is a momentary short in a conductor carrying this power or by a malfunction of equipment being supplied from this power source.

The most likely phenomena that would produce such a momentary short is an inadvertent electric arc either within electrical equipment or between a power conductor and the Command Module structure. Such an arc is nominally the result of electrical insulation failure.

No data recorded during the interval of the electrical abnormality shows any variance that could be interpreted as a momentary short in DC bus B power, or DC bus A power. Tests show that a drop in DC voltage to a level below 19 volts for as short a time as two milliseconds is sufficient to affect the inverter and the AC bus. Because all telemetry data is sampled at discrete intervals, a short of two milliseconds duration probably would not appear in the data.

All equipment and wiring has been examined for any and all evidence of arcs, shorts and suspicious appearance, to help explain the electrical abnormality. All items of equipment, except for specific wiring, have been placed into an improbable ignition source category.

Ten cases of arced, shorted and/or suspicious looking wiring have been identified. Tests and analyses are being conducted on a number of these at this time. From this listing, however, only one is considered suspect as being the cause of the electrical abnormality. It can also be the trigger or source of ignition that caused the accident.

The one suspect is wiring providing instrumentation power for some Environmental Control System instrumentation. This wiring contains both DC bus A and DC bus B power, and is located on the Command Pilot side of the Command Module in the vicinity of the Environmental Control Unit and the Lithium Hydroxide Units.

A momentary short could occur in any of four DC bus B or four DC bus A power wires in this wiring. A short would not affect the equipment being powered by these wires, and would not be reflected in any of seven measurement outputs of transducers being provided power because of redundant power with diode isolation for each equipment.

Tests have shown that a short in any of the four DC bus B wires could cause a drop in DC bus B voltage to a level low enough to cause an interruption to inverter 2. A test

has been conducted at Launch Complex 34, with an inverter, to simulate this shorting.

Debris netting traversing the floor on the left side of the C/M was within inches of the wire harnesses. If ignited, the netting would burn along the floor toward a vertical flammable material. The vertical material on the left was the polyurethane foam on the Environmental Control Unit evaporator, approximately 7 inches away from the wires. The vertical material on the right, was the debris netting in the corner of the S/C by the water panel, approximately 13 inches away from the wires. The average burning rate of debris netting in a 14.5 psi oxygen environment in a horizontal direction has been determined to be 2 inches per second.

Assuming that this burning rate is valid, it can be postulated that the polyurethane foam on the evaporator would ignite at about 4 seconds and the vertical debris netting in the corner at about 8 seconds after the initial netting ignition. The front cover of the ECU was not installed and the netting on the floor was a couple of inches away from the polyurethane foam on the evaporator. Because of this, it is inferred that the vertical netting in the corner would be the first instance of vertical burning. Vertical burning would occur at about 23:31:03 GMT. Allowing one second for the flames to reach the couch level, the first voice transmission of trouble from the Command Pilot at 23:31:04.7 GMT occurs at the proper time. Unfortunately, there is no physical evidence to support a conclusive determination. This wiring was located in the area where burning was at the highest intensity. Sections of these wires, six to twelve inches long, in the suspect location have been completely burned away.

#### D. FINDINGS AND DETERMINATIONS

##### 1. Findings:

Several arcing indications were observed in the Command Module -Y +Z sector and a voltage transient was noted in all three phases of AC bus 2. This transient was most closely simulated by a power interruption or short circuit on DC bus B.

Physical evidence and witness statements indicated the progress of the fire to be from the left side of the Spacecraft.

Simulations and tests indicate that combustion initiation due to electrostatic discharge or chemical action is not probable.

No physical evidence of pre-fire overheating of mechanical components or heating devices was found.

Determinations:

No single ignition source could be conclusively identified.

The most probable initiator is considered to be electrical arcing or shorting in the sector between the -Y and +Z Spacecraft axis.

The location best fitting the total available information is that where ECS instrumentation power wiring runs into the area between the ECU and the oxygen panel.

2. Finding:

All Spacecraft records have been reviewed by the various Panels and the results were screened by Panel 18.

Determination:

No evidence has been found to correlate previously known discrepancies, malfunctions, qualification failures or open work items with the source of ignition.

3. Finding:

At the time of the observed fire, data including telemetry and voice communications indicate no malfunctioning Spacecraft systems (other than the live microphone).

Determination:

Existing Spacecraft instrumentation was insufficient by itself to provide data which would identify the source of ignition.

E. SUPPORTING DATA

List of Enclosures

<u>Enclosure</u>	<u>Description</u>
18-1	Sample of Disassembly and Post-Disassembly Requirements Form
18-2	Sample of Test Preparation Sheet
18-3	Sample of Board Action Summary Page
18-4	Listing of Open Circuit Breakers
18-5	VHF/AM and S-Band Voice Recordings
18-6	Transcript of Voice Channel for Last 27 Seconds
18-7	Gas Chromatograph Trace
18-8	AC Bus 2 Data and Associated Changes
18-9	Oxygen Flow Rate and Associated Data
18-10	Oxygen Flow Rate Correlation
18-11	Not used
18-12	ECS Data Correlation
18-13	Surge Tank Pressure Profile
18-14	Motion Indications
18-15	Navigation Base Installation
18-16	Spacecraft and IMU Stable Member Axes
18-17	Navigation Base Installation Detail
18-18	Navigation Base Pitch Angle Change Versus Cabin Pressure

<u>Enclosure</u>	<u>Description</u>
18-19	Selected Temperature, Pressure, and Inertial System Measurements Versus Time
18-20	Suit O <sub>2</sub> Flow Rates
18-21	Gas Chromatograph Trace Comparison
18-22	Electrical Power System
18-23	AC Bus 2 Special Tests
18-24	Audio Key Lines
18-25	Environmental Control System Instrumentation Harnesses Before Accident
18-26	Environmental Control System Instrumentation Harness Wiring Identification
18-27	Spacecraft 014 Environmental Control System Instrumentation Harnesses
18-28	Environmental Control System Instrumentation Harnesses After Accident
18-29	Cover of J-Box C15-1A52
18-30	Arced Point on Wire and Cover of J-Box C15-1A52
18-31	Arc Point on Cover of J-Box C15-1A52
18-32	Arc Point on Wire Related to Cover of J-Box C15-1A52
18-33	Undisturbed Location of Gas Chromatograph Connector
18-34	Area Under Gas Chromatograph Connector
18-35	Side of Gas Chromatograph Connector Which Protected Spot Ties on Harness on Floor

<u>Enclosure</u>	<u>Description</u>
18-36	Copper Droplets on Gas Chromatograph Wires
18-37	Copper Flow and Nickel Pipe Effect on Gas Chromatograph AC Wires
18-38	Shorted DC Wires Above Entry Batteries
18-39	Detail of Shorted Wires Above Batteries
18-40	Location of Cabin Fans
18-41	Main Display Console Panel Number 8 Switch S-11 Wiring
18-42	Location of Octopus Cable J185 Connector
18-43	Detail of J185 Connector
18-44	Shorting on Octopus Cable
18-45	Power Harness to J185 Connector
18-46	Suit Compressor Wiring After Accident
18-47	Not Used
18-48	Command Pilot's Suit Wiring
18-49	Detail of Command Pilot's Communication Harness
18-50	Location of Switch S11 on Panel 8
18-51	Short to Structure by Terminal of Switch S11
18-52	Complete "Status of Investigation Items" dated April 1, 1967
18-53	"Integration Analysis Summary" for each investigation item as available on April 1, 1967
18-54a	"Review of Spacecraft Power Status", dated February 6, 1967, prepared by Panel 18



Enclosure

Description

18-54b	"Supplement to Review of Spacecraft Power Status", dated February 23, 1967, prepared by Panel 1.
18-55	Complete set of "Potential Initiation Theories Evaluation Sheets", dated March 28, 1967.
18-56	Brief Summary of Significant Special Test Results
18-57	List of References

This page left blank intentionally.

SAMPLE OF DISASSEMBLY AND POST-DISASSEMBLY REQUIREMENTS FORM

<p><u>NO.0060 REMOVE COVER C15-1A 52 JUNCTION BOX</u></p>	
<p><u>DESCRIPTION of TASK</u> 2/9                  REMOVE MECHANICAL COVER ON                  C15-1A 52 JUNCTION BOX                  INSPECT WIRING WHERE SCREWDRIVER                  INCIDENT OCCURRED</p>	<p><u>SUBSYSTEM</u>                  ELECT.</p>
<p><u>CONSTRAINTS</u>                  NONE</p>	<p><u>PRIME REASON</u>                  INSPECTION</p>
<p><u>URGENCY - RATIONAL</u>                  MAY HAVE CONTRIBUTED TO CAUSE</p>	

# INVESTIGATION

NON-CONFIGURATION & DOWNY OPERATIONS	
--------------------------------------	--

TRIPLE E AVIATION, INC.  
SERVICE AND INFORMATION SYSTEMS DIVISION

TR. NO. <u>SC012-SC002</u>		
S/C	CAT.	NO.

MOD. SHEET NO. \_\_\_\_\_ TEST PREPARATION SHEET PAGE 1 OF 1

INSTALLING ORGANIZATION <u>SYSTEMS ENGINEERING</u>			
PROJECT NO. <u>VIA-3</u>	DATE <u>2-10-67</u>	TIME <u>1300</u>	NEED DATE <u>AS SCHEDULED</u>
DRAWING(S), DOCUMENTS, OTPO, & PART NO. <u>V16-880225</u>			
PARTS WITHING REQ. <u>N/A</u>		S/N	
SYSTEM <u>EPS</u>			
T/S SUBJECT TITLE <u>REMOVE COVER</u>			
REASON FOR WORK <u>TO INSPECT AREA BEHIND CLOSE OUT PANEL OVER C15-1A52</u>			

DESCRIPTION (Print or Type)	TECH	NAA	INSP. NASA
VERIFY EO NO. _____ EO LOG RECORD CLEARED			
NOTE: BEH'D TO BE WORKED ON SC014			
CONSTRAINED BY SC012-SC009			
1. PHOTOGRAPH C15-1A52, PNL LOWER EXP. BAY.			
2. CAREFULLY BACKOUT 4 MTR. SCREWS AND WASHERS FROM C15-1A52 HOLDING PANEL V16-441802 (REF V16-880225), TO PREVENT IT FROM FALLING.			
3. PLACE PANEL AND MOUNTING HARDWARE IN PLASTIC BAG IDENTIFY BAG AS TO CONTENTS.			
4. SEND BAG TO PLB BOND ROOM FOR STORAGE.			

PART WEIGHED & RECORDED, IF REQUIRED	
PREPARED BY <u>J. Amores 748</u>	FINAL ACCEPTANCE DATE _____
Refer to local procedures for specific approvals	Refer to local procedures for specific approvals
<u>W. H. (Hodges) 10278 1067</u> <u>W. H. (Hodges) 10278 1067</u> <u>W. H. (Hodges) 10278 1067</u> <u>W. H. (Hodges) 10278 1067</u>	<u>W. H. (Hodges) 10278 1067</u> <u>W. H. (Hodges) 10278 1067</u> <u>W. H. (Hodges) 10278 1067</u> <u>W. H. (Hodges) 10278 1067</u>

ENCLOSURE 18-2: SAMPLE OF TEST PREPARATION SHEET

BOARD ACTION SUMMARY

ACTION	DESCRIPTION	REASON	BRD APP DATE	TPS #	RESULT SUMMARY
0057 CLOSED B	Remove Pyro Batteries	Only active power source still in C/M	2/8	109	TPS complete 2/15/67. C/M batteries removed. Terminals in good condition. Slight coating of soot.
0058 CLOSED B	Disconnect SM Jettison Controller Batteries.	Remove Active power source on S/M.	2/8	087	TPS complete 2/10/67. Electrical power was removed and battery terminals insulated.
0059 CLOSED A	Inspect ECU Wiring (Non-destructive)	Routine check. Summary required for each S/C entry.	2/8	062	Inspection indicated burned and bare wires. Low level continuity checks and engineering analysis will be performed under Action #0179.
0060 CLOSED	Remove mechanical cover on C15-1A52 Junction Box  ENCLOSURE 18-3:	Inspect wiring where screwdriver incident occurred.  SAMPLE OF BOARD ACTION SUMMARY	2/8	082	TPS complete 2/12/67. See Action 0037 for summary and/or analysis. Reference Investigation Item 47.

LIST OF OPEN CIRCUIT BREAKERS

PANEL 22 RIGHT-HAND CIRCUIT BREAKER PANEL

<u>No.</u>	<u>Identification</u>	<u>Rating</u>	<u>Condition</u>
CB18	Master Event Seq. Controller Arm B	5 Amp	HS
CB15	DC Sensor Signal Main A	5 Amp	HS
CB117	Scientific Equipment Bay 1 (J185)	20 Amp	HS
CB118	Scientific Equipment Bay 2 (above batteries)	20 Amp	HS
CB77	Battery Charger Batt B	10 Amp	BS
CB116	Gas Chromatograph AC1	2 Amp	HS
CB45	Telecommunications Group 5	7.5 Amp	HS
CB94	ECS H <sub>2</sub> O Accumulator Main A	5 Amp	NS
CB76	Cabin Air Fan 1 AC1 Phase A	2 Amp	VLS
CB74	Cabin Air Fan 1 AC1 Phase C	2 Amp	S
CB33	ECS Suit Compressor AC1 Phase A	2 Amp	HS
CB32	ECS Suit Compressor AC1 Phase B	2 Amp	HS
CB92	ECS Waste and Potable H <sub>2</sub> O Main A	5 Amp	HS
CB91	ECS Waste and Potable H <sub>2</sub> O Main B	5 Amp	S
CB43	ECS Transducer pressure group 2 Main A	5 Amp	B
CB34	ECS Transducer pressure group 2 Main B	5 Amp	VLS
CB11	ECS Temperature Main A	5 Amp	MS
CB10	ECS Temperature Main B	5 Amp	LS

PANEL 21 RIGHT-HAND SIDE CONSOLE BUS SWITCHING PANEL

CB8	Sensor Unit AC Bus 2	5 Amp	NS
-----	----------------------	-------	----

PANEL 25 LEFT-HAND CIRCUIT BREAKER PANEL

CB33	SCS B and D Roll Main B	20 Amp	VLS
CB39	SCS Pitch Main B	20 Amp	NS
CB31	SCS Yaw Main B	20 Amp	MS
CB26	Gimbal Motor Control 1 Pitch Battery A	15 Amp	HS
	Gimbal Motor Control 1 Yaw Battery A	15 Amp	HS
CB16	RCS Propellant Isolate Main A	15 Amp	LS
CB15	RCS Propellant Isolate Main B	15 Amp	MS
CB52	EDS 1 Battery A	5 Amp	MS
CB53	EDS 3 Battery B	5 Amp	MS

PANEL 203

CB3	Inverter Power No. 2 Main B	70 Amp	NS
-----	-----------------------------	--------	----

PANEL 150

CB14	Pyro A Seq. A	20 Amp	NS
CB17	Pyro B Seq. B	20 Amp	S
CB20	Battery Charger Battery C	5 Amp	NS

PANEL 204 INSTRUMENTATION POWER CONTROL

CB3	Essential Instrumentation	7 Amp	
-----	---------------------------	-------	--

Condition Code:

B - BURNED

S - SOOTY

NS - NO SOOT

MS - MEDIUM SOOT

HS - HEAVY SOOT

LS - LIGHT SOOT

BS - BURNED SOOT

VLS- VERY LIGHT SOOT



TRANSCRIPT OF VOICE CHANNEL FOR LAST 27 SECONDS

MOLC VHF/AM TRACK TRANSCRIPT	MOLC S-BAND TRANSCRIPT
23:30:58.5 (Short noise 0.6 sec.)	23:30:55.5 (Noise)
23:31:10.0 (First voice transmission)	23:30:56 (Breathing sound)
23:31:10.0 (End of first transmission)	23:30:56.5 (Noise)
23:31:17.1 (Second voice transmission)	23:30:58.1 (Noise)
23:31:21.8 (End of second transmission)	23:31:04 (Breathing sound)
	23:31:04.7 (First voice transmission of Spacecraft problem)
	23:31:10.0 (End of transmission)
	23:31:16.8 (Second voice transmission of Spacecraft problem)
	23:31:21.8 (End of second transmission)
	23:31:22.4 (LOS)

# GAS CHROMATOGRAPH TRACE

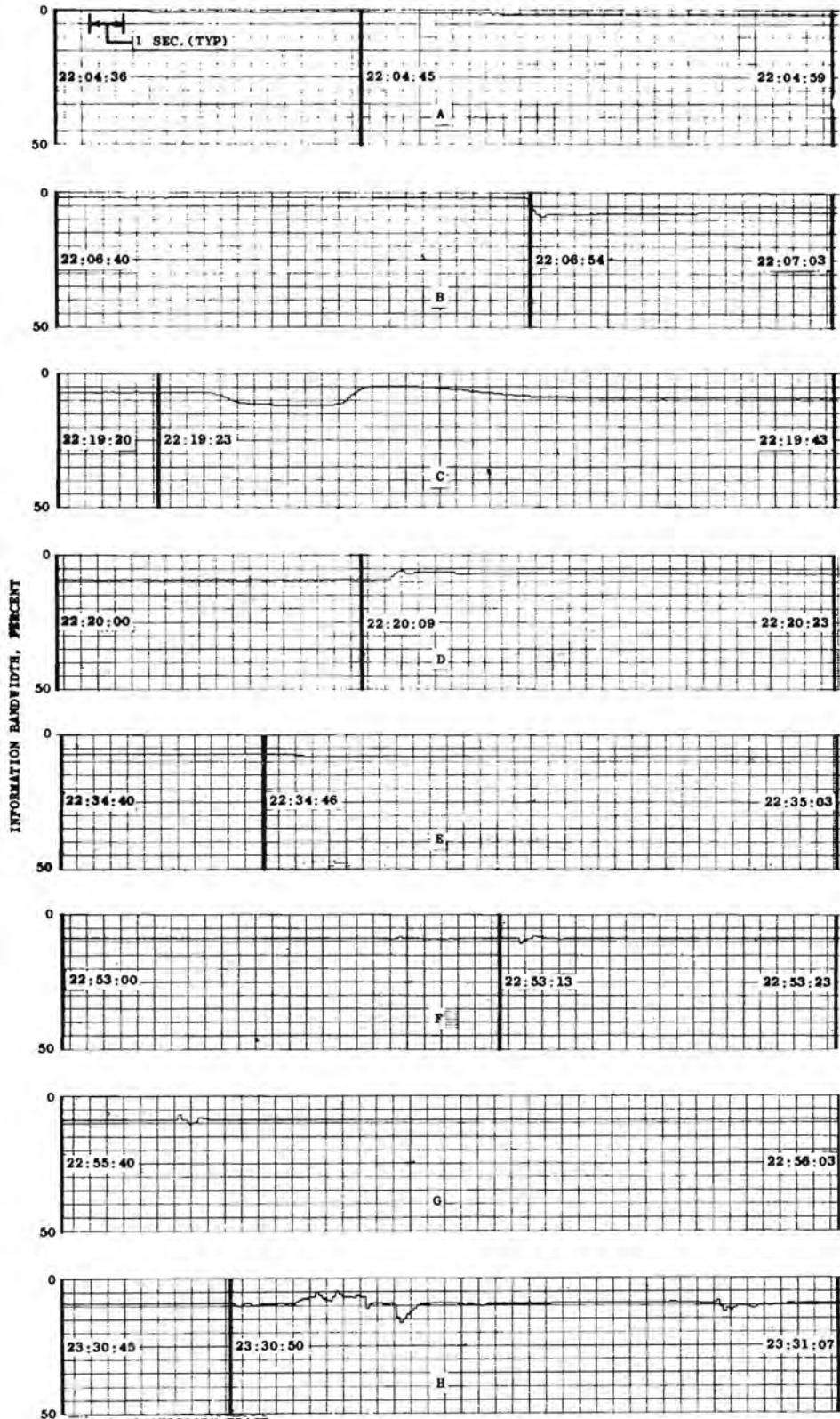

GAS CHROMATOGRAPH TRACE  
MEAS. NO. CT0108E  
RECORD SPEED 10MM/SEC.  
2.5V - FULL SCALE

ENCLOSURE 18-7

D-18-66

# AC BUS 2 DATA AND ASSOCIATED CHANGES

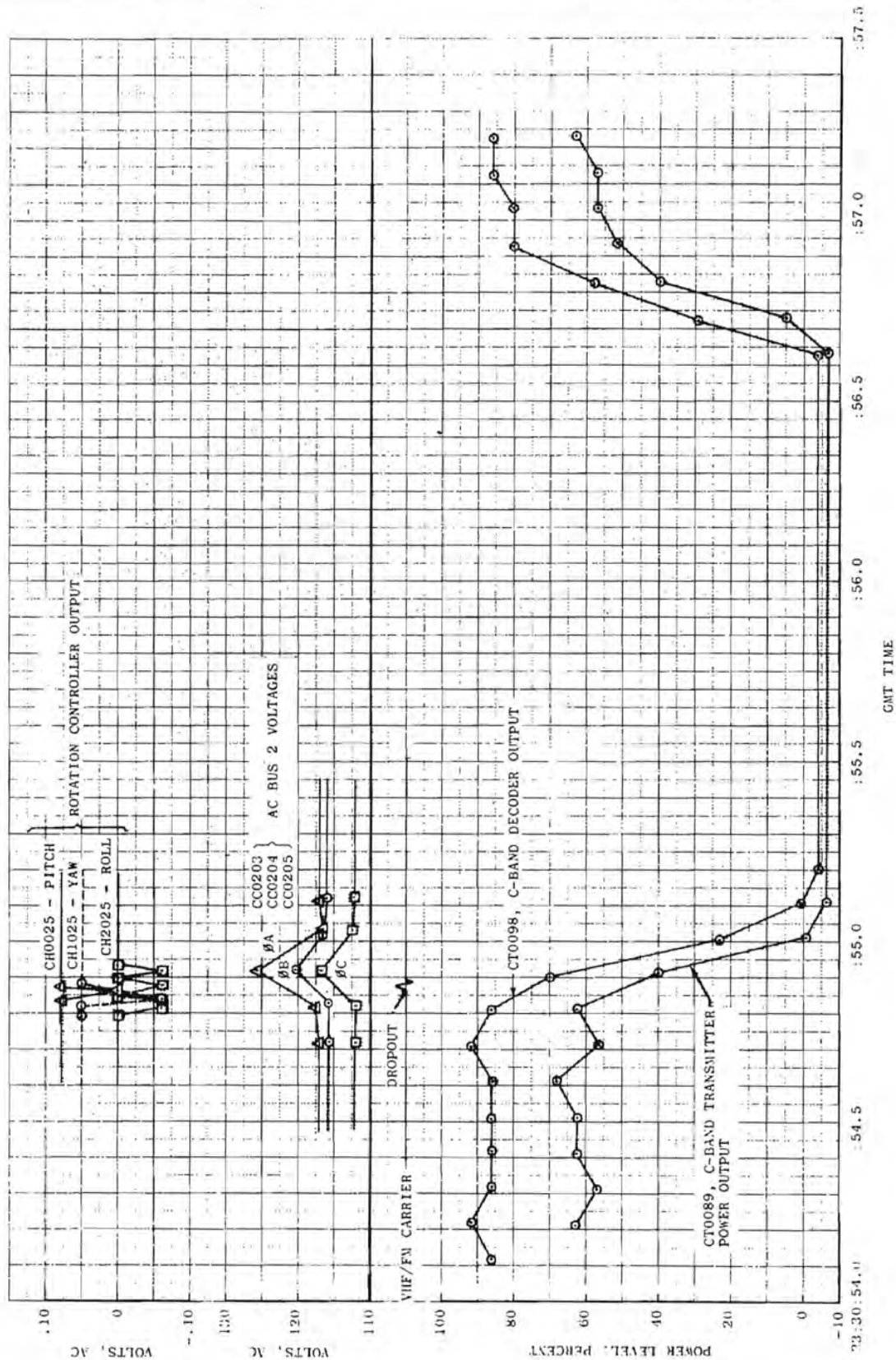

# OXYGEN FLOW RATE AND ASSOCIATED DATA

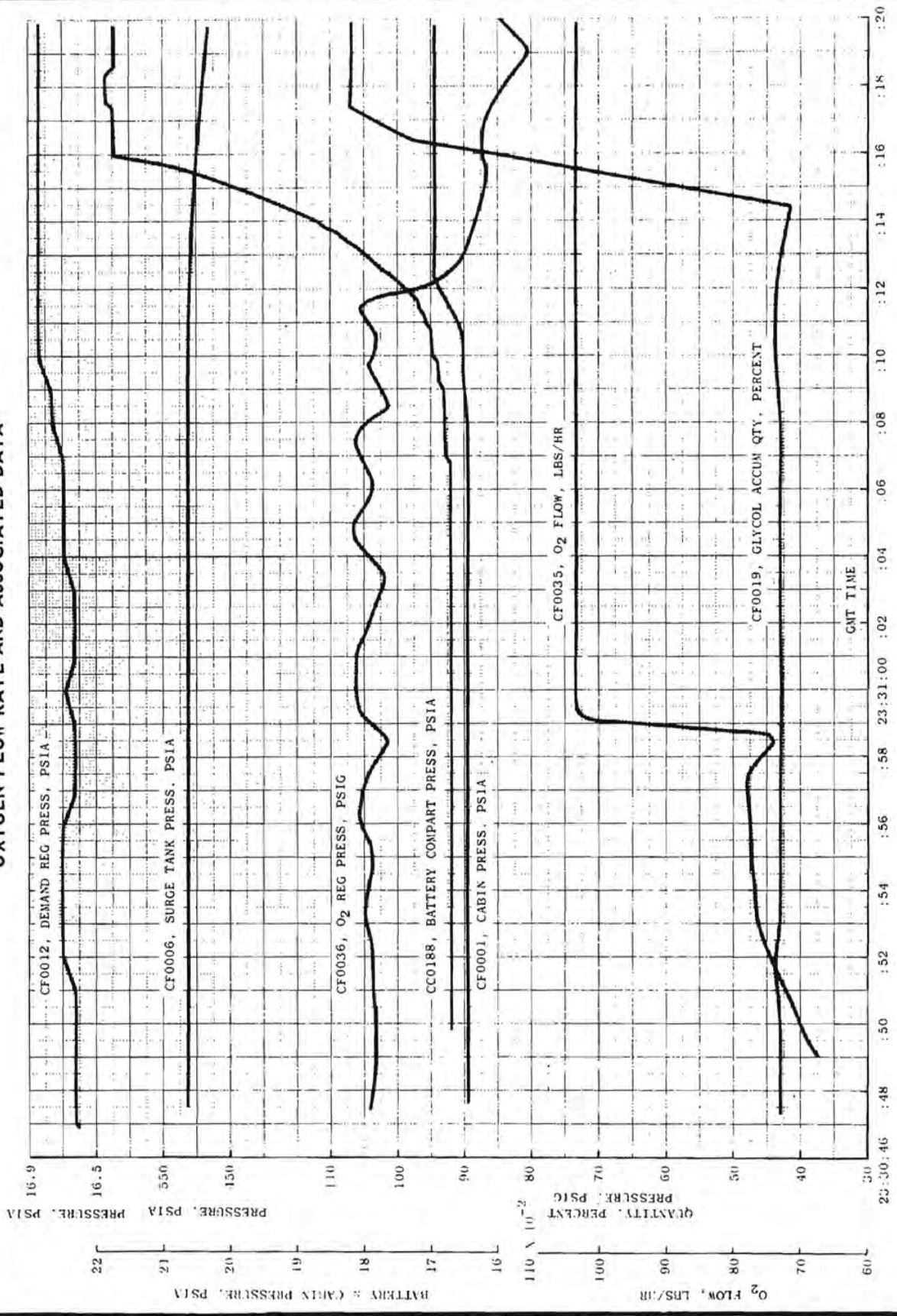

**OXYGEN FLOW RATE CORRELATION**

(Correlation of relevant data for unexplained periods when oxygen flow rate (CF0085R) indicates maximum value of 1.033 lb./hr.)

TIME (start/end)	DURATION (min:sec)	C&W INDICATION (on/off)	SURGE TANK PRESSURE CHANGES (psia-start/end)	AVERAGE FLOW (lb./hr.)	MAX RATE OF FLOW INCREASE (lb./hr./sec.)	SUIT PRESSURE CHANGES
1. 20:20:30/ 20:20:41	00:10	None	None	≥1.033	0.09	Yes
2. 21:27:43/ 21:27:51	00:08	None	None	≥1.033	0.12	Yes
3. 21:28:34/ 21:28:40	00:06	None	None	≥1.033	0.14	Yes
4. 21:45:54/ 21:46:29	00:35	21:46:/ 21:46:26	None	≥1.033	0.11	No
5. *22:46:07/ 22:46:24	00:17	22:46:22/ 21:46:24	None	≥1.033	0.24	Yes
6. *22:52:07/ 22:53:18	01:11	22:52:22/ 22:52:48	734.7/730.5	3.80	0.09	Yes
7. *22:53:47/ 22:54:16	00:29	22:54:01/ 22:54:05	None	≥1.033	0.06	Yes
8. *22:54:24/ 22:54:24	00:16	None	None	≥1.033	0.03	Yes
9. **23:19:13/ 23:23:14	04:01	23:19:28/ 23:19:34	739/480.6	≥22.28	0.33	Yes
10. 23:24:03/ 23:24:06	00:03	None	None	≥1.033	0.33	Yes
11. *23:30:59/LOS		23:31:15/LOS	514.5/484.8	64.3	0.29	Yes

NOTE: Average flows computed from surge tank pressure data. \*Voice tape indicates crew activity. \*\*Command Pilot face plate open.

ECS DATA CORRELATION

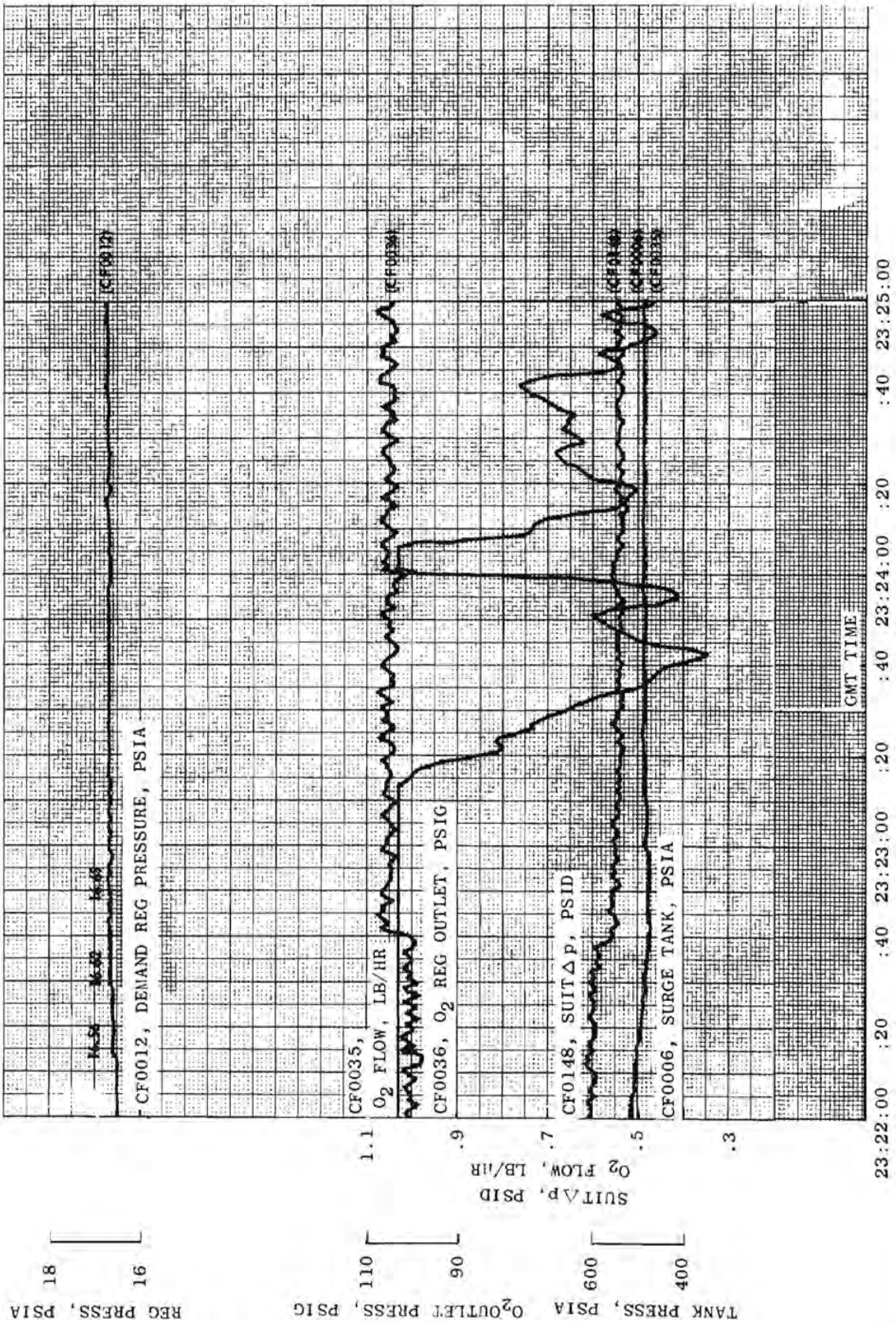

# ECS DATA CORRELATION

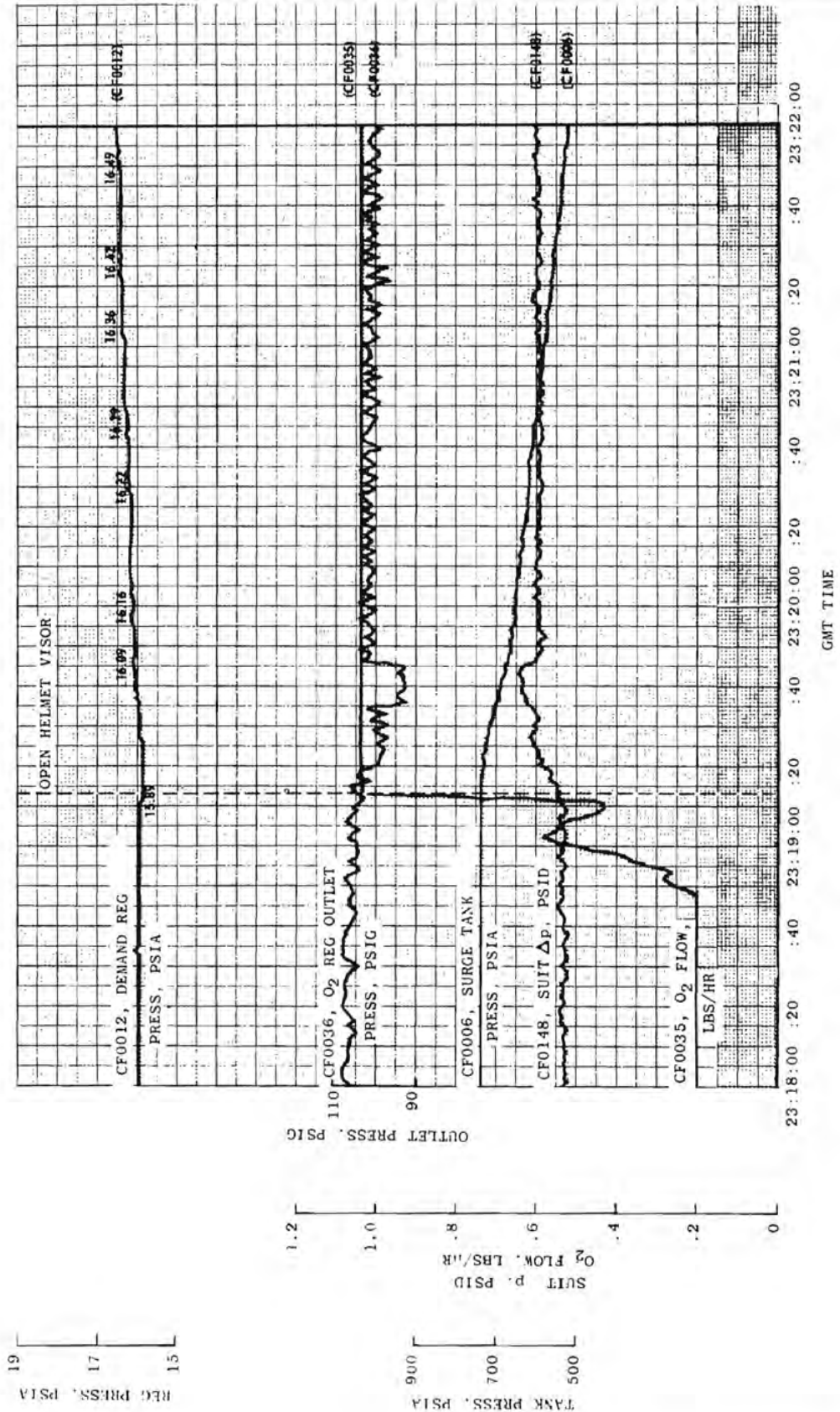

# ECS DATA CORRELATION

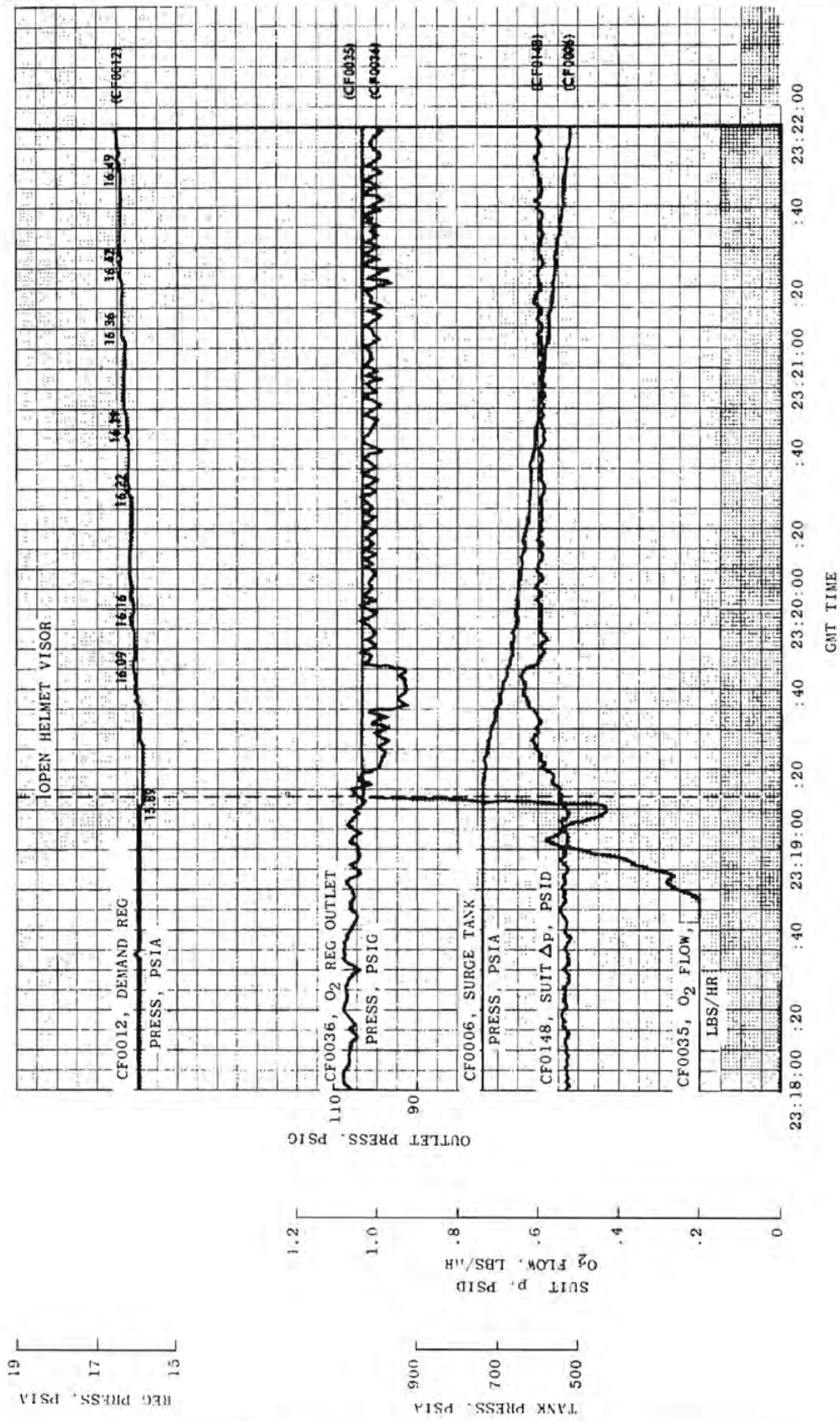



SURGE TANK PRESSURE PROFILE

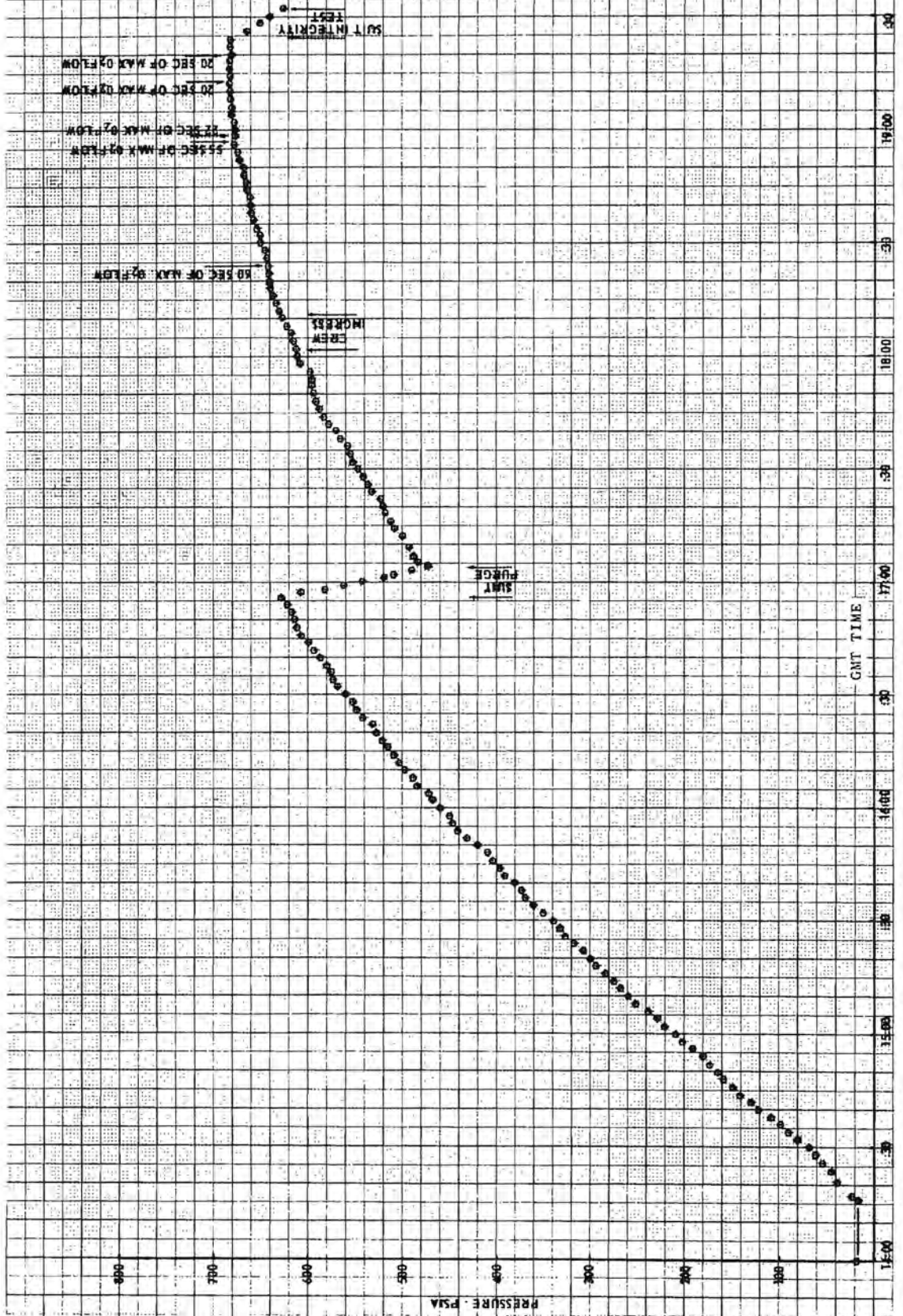

SURGE TANK PRESSURE PROFILE

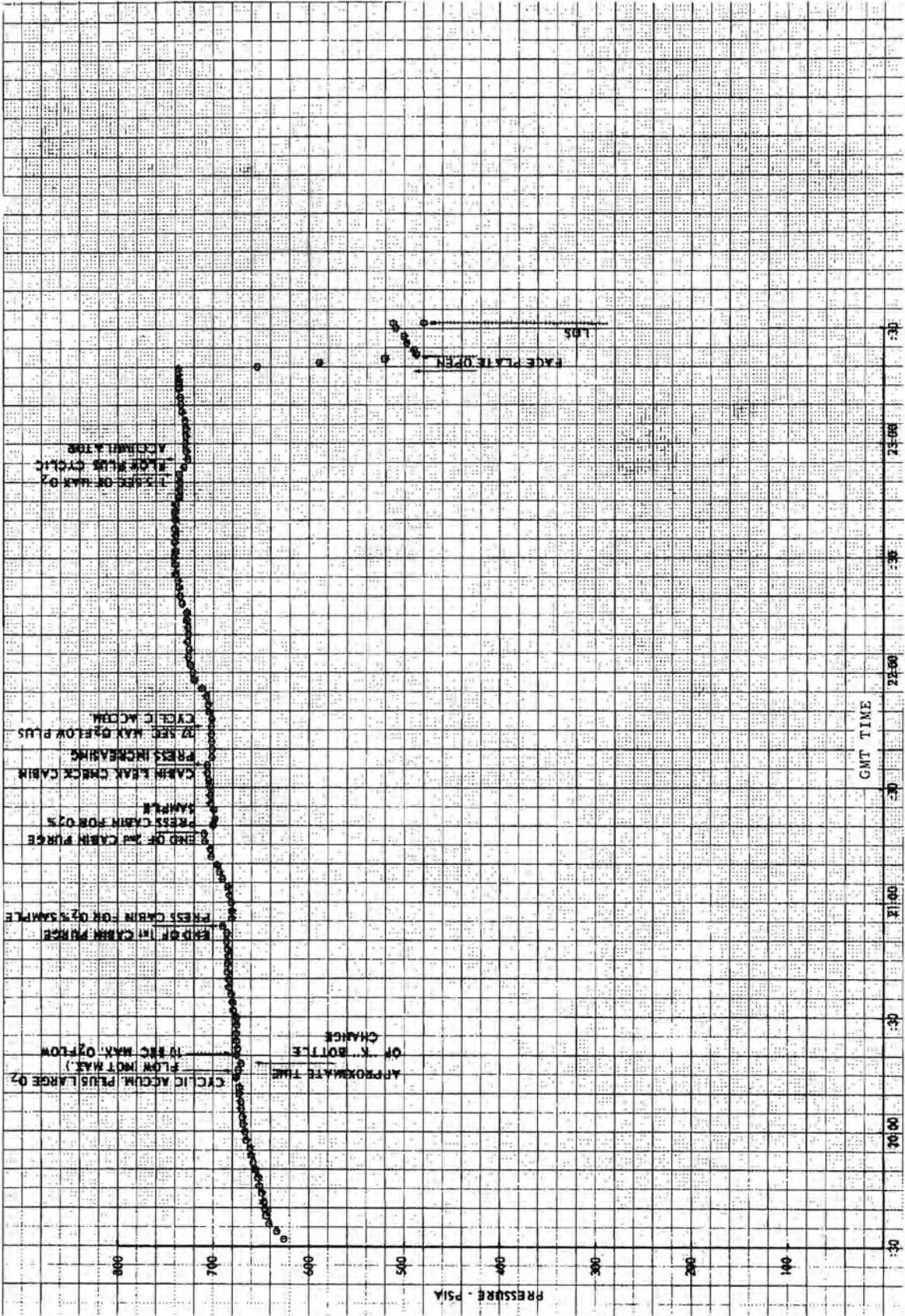

# MOTION INDICATIONS

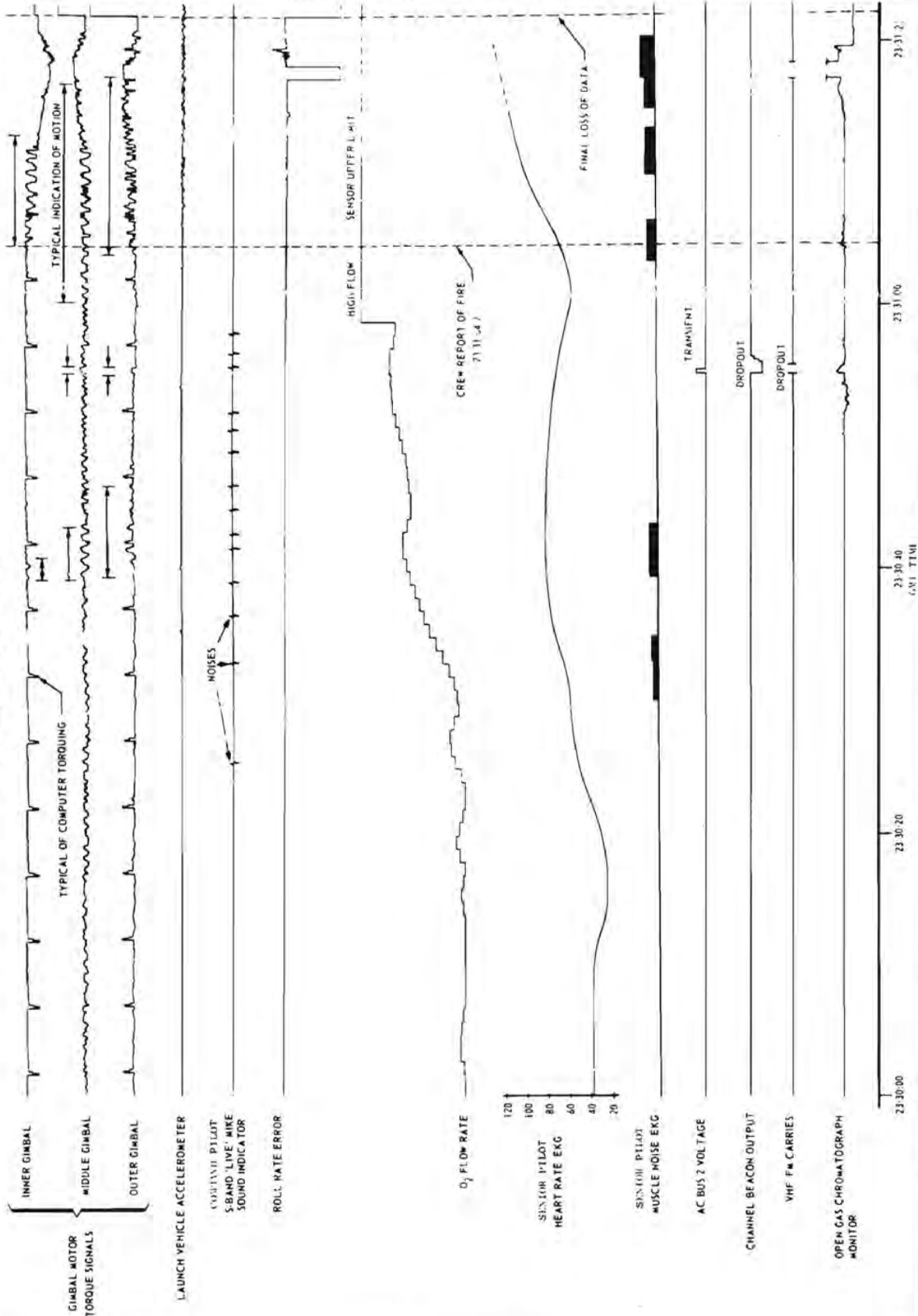

# NAVIGATION BASE INSTALLATION

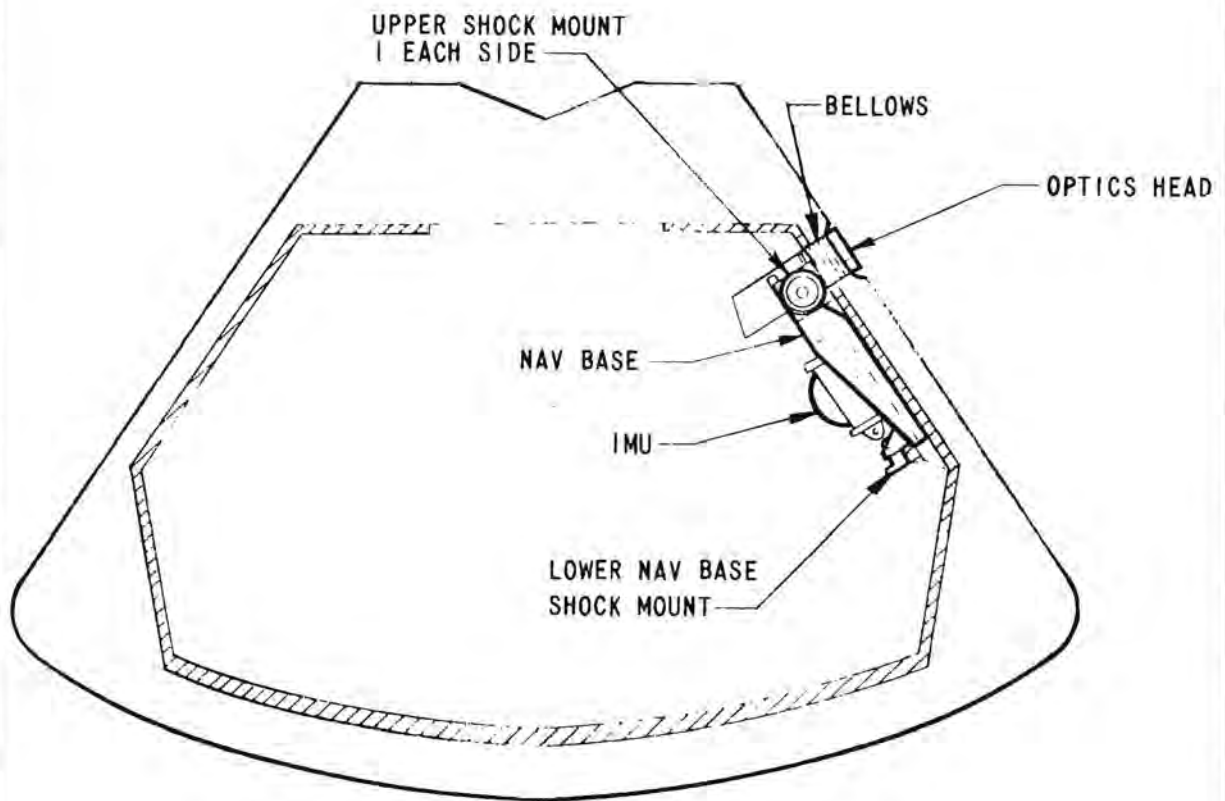

ENCLOSURE 18-15

D-18-75

SPACECRAFT AND IMU STABLE MEMBER AXES

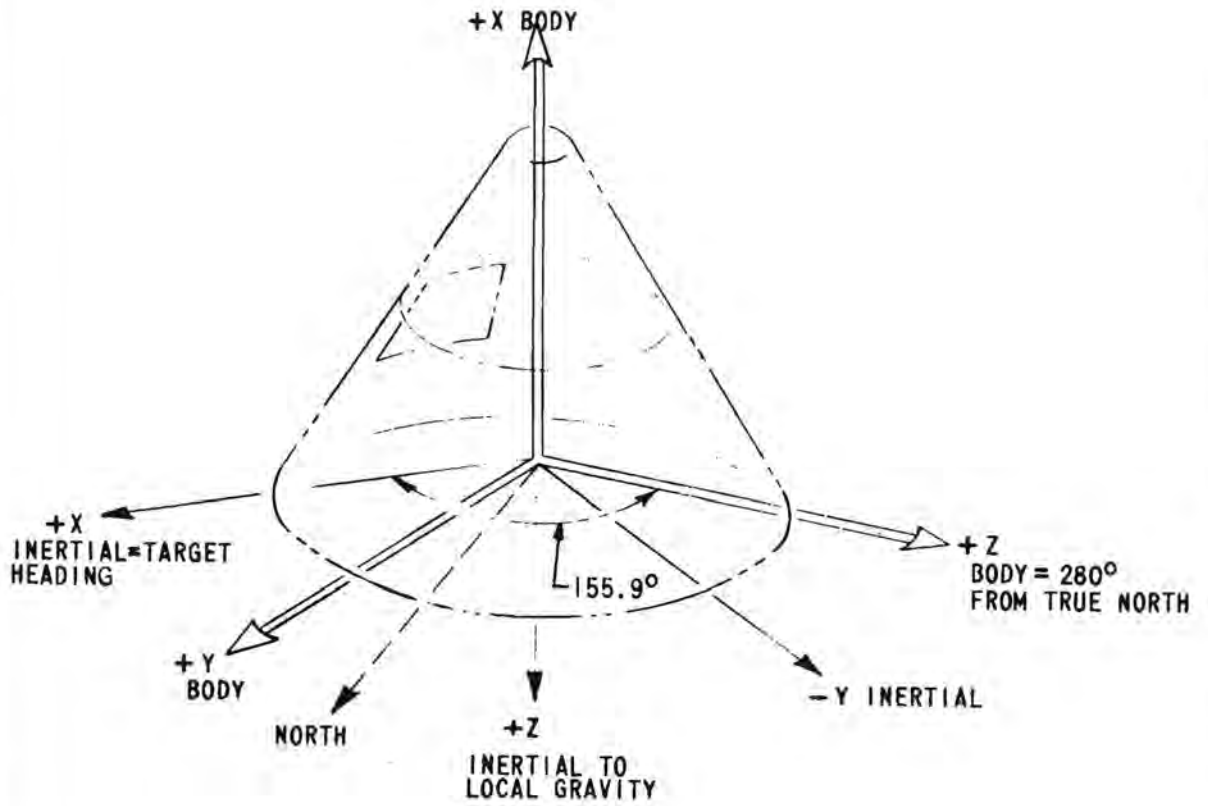

# NAVIGATION BASE INSTALLATION DETAIL

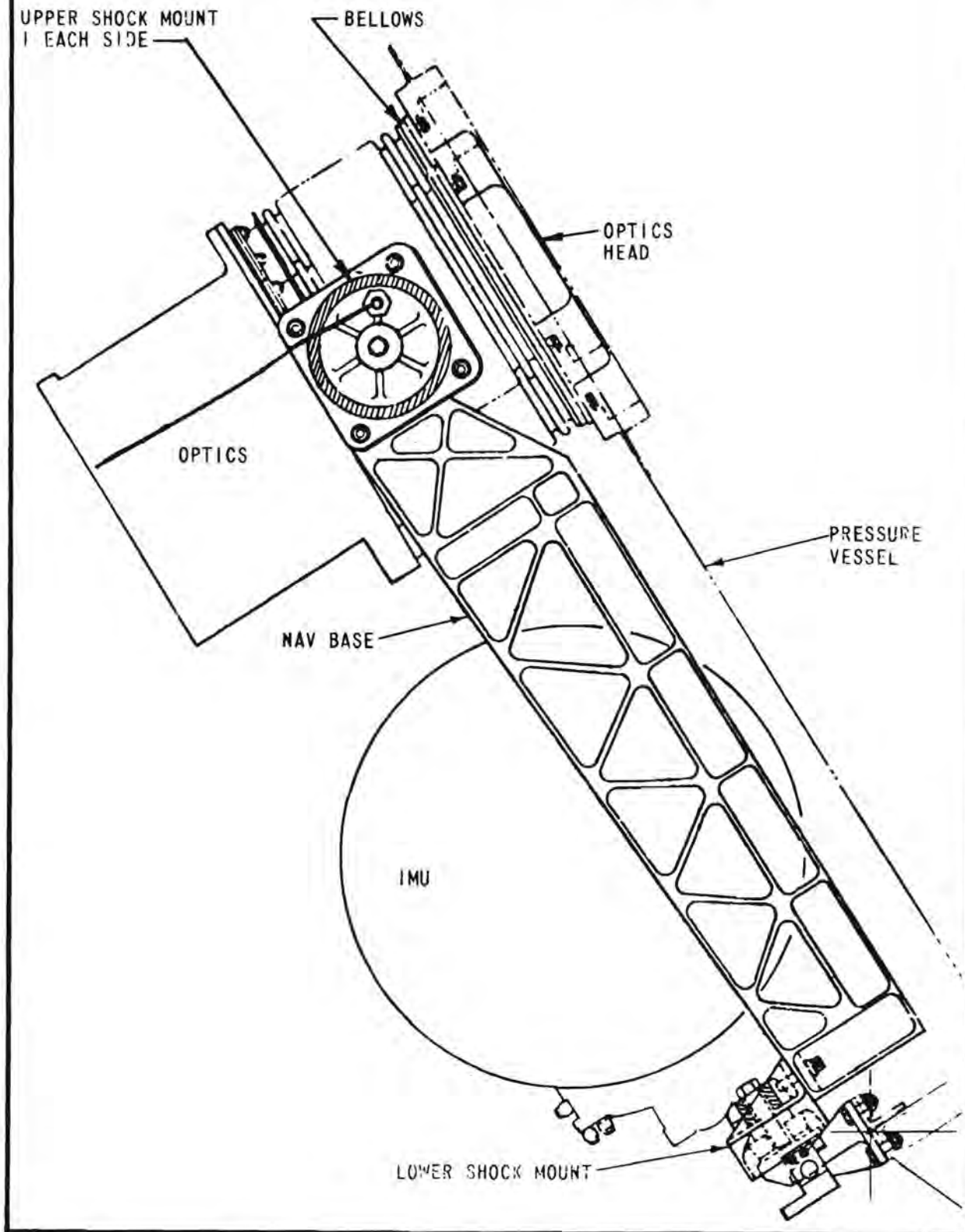

ENCLOSURE 18-17

D-18-77

# NAVIGATION BASE PITCH ANGLE CHANGE VERSUS CABIN PRESSURE

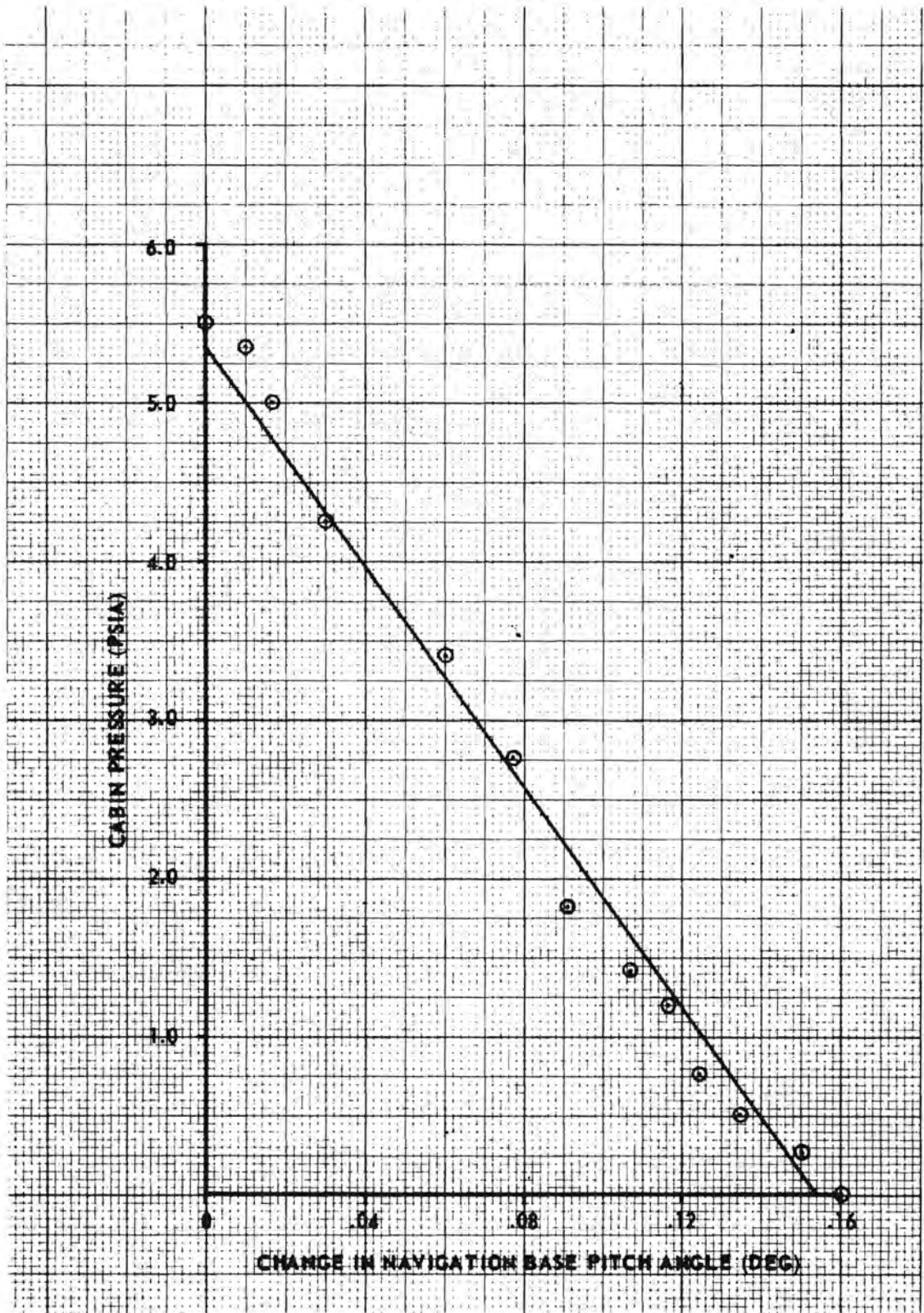

ENCLOSURE 18-18

D-18-78

## SELECTED TEMPERATURE, PRESSURE, AND INERTIAL SYSTEM MEASUREMENTS VERSUS TIME

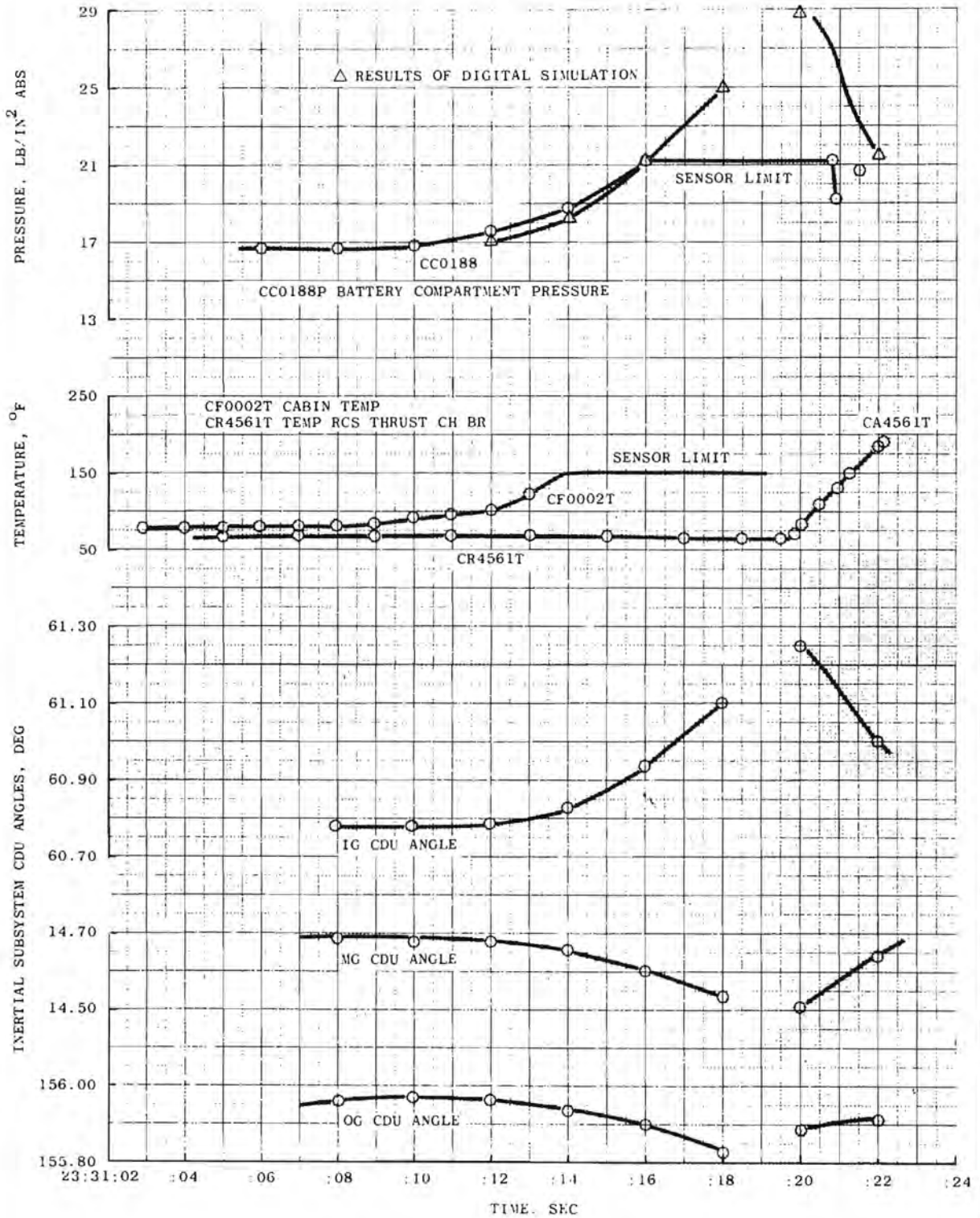



# SUIT O<sub>2</sub> FLOW RATES

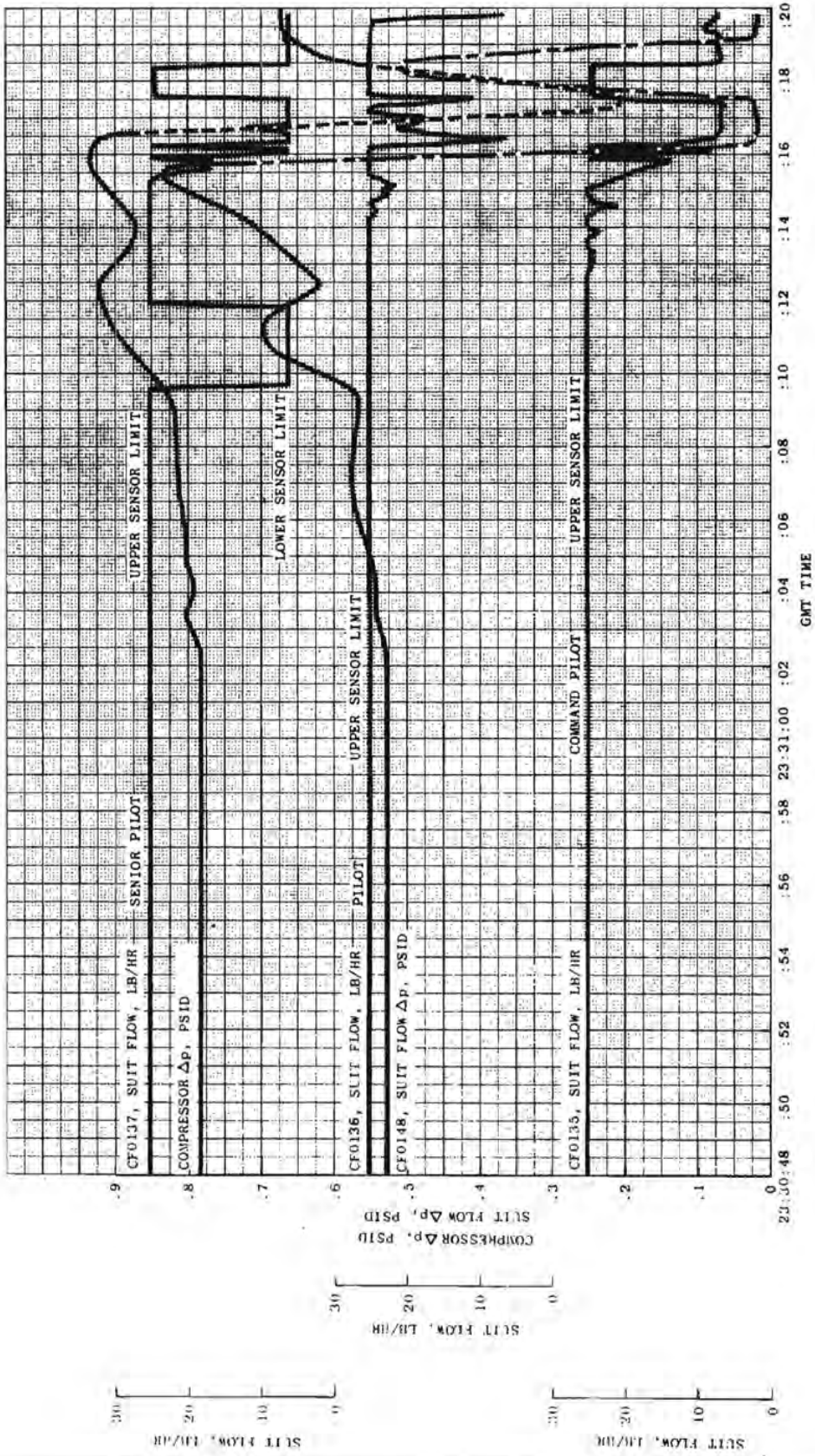

GAS CHROMATOGRAPH TRACE COMPARISON

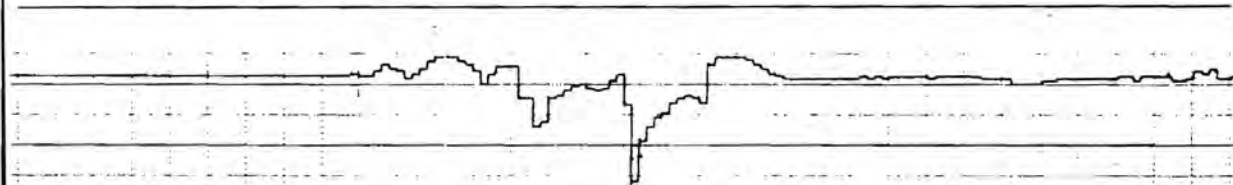

A. S/C 008 AT MSC

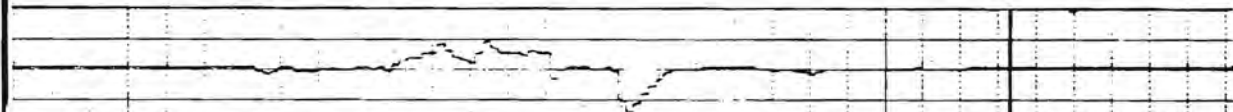

23:31:00

B. S/C 012 AT KSC



C. DOWNEY TEST

GAS CHROMATOGRAPH TRACE  
MEAS. NO. CT0108K  
RECORD SPEED 10MM/SEC.  
2.5V = FULL SCALE

This page left blank intentionally.

**POWER CONFIGURATION DURING ELECTRICAL ANOMALY**

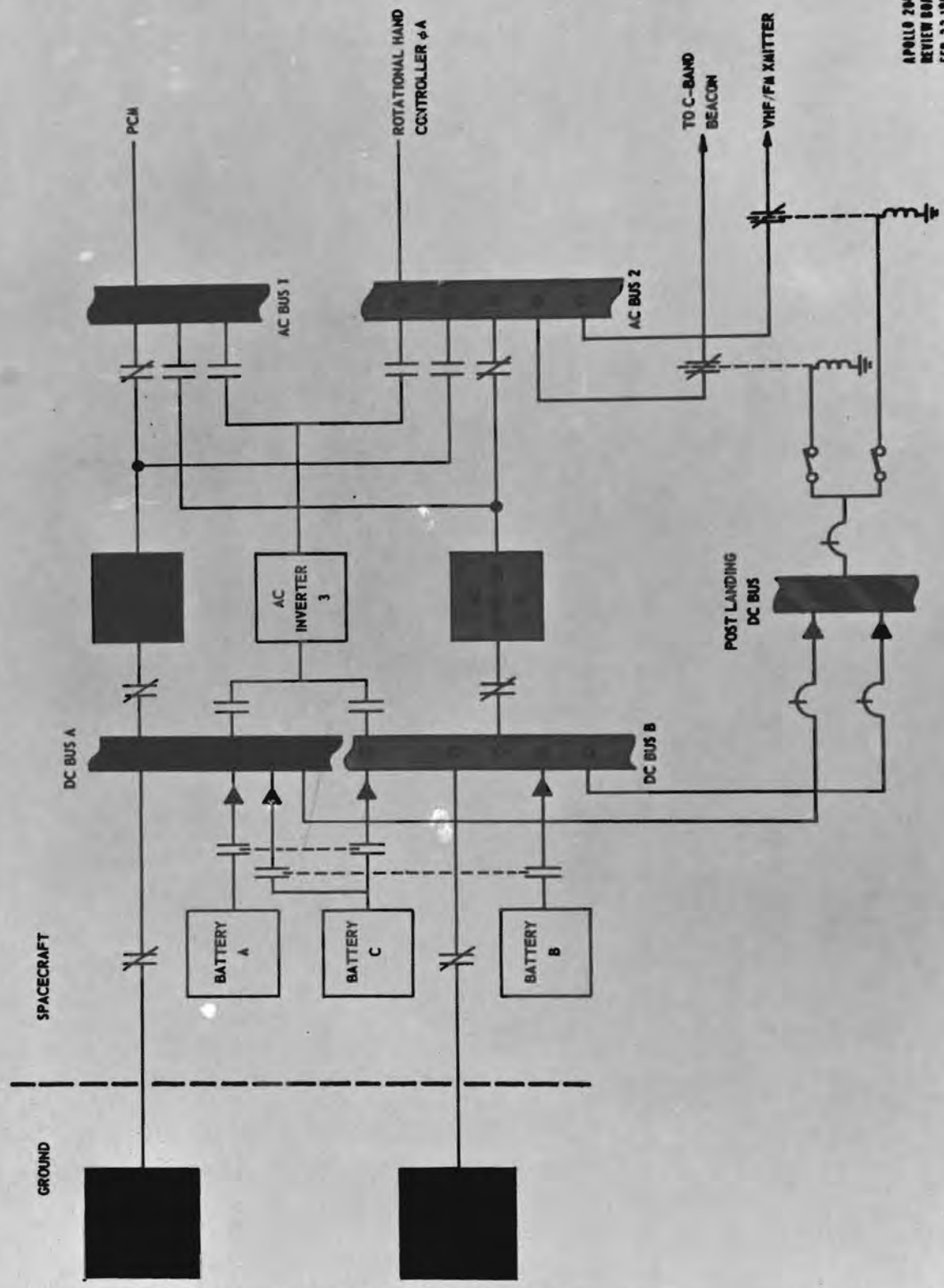

APOLLO 204  
 REVIEW BOARD  
 FEB. 22, 1967  
 5 5

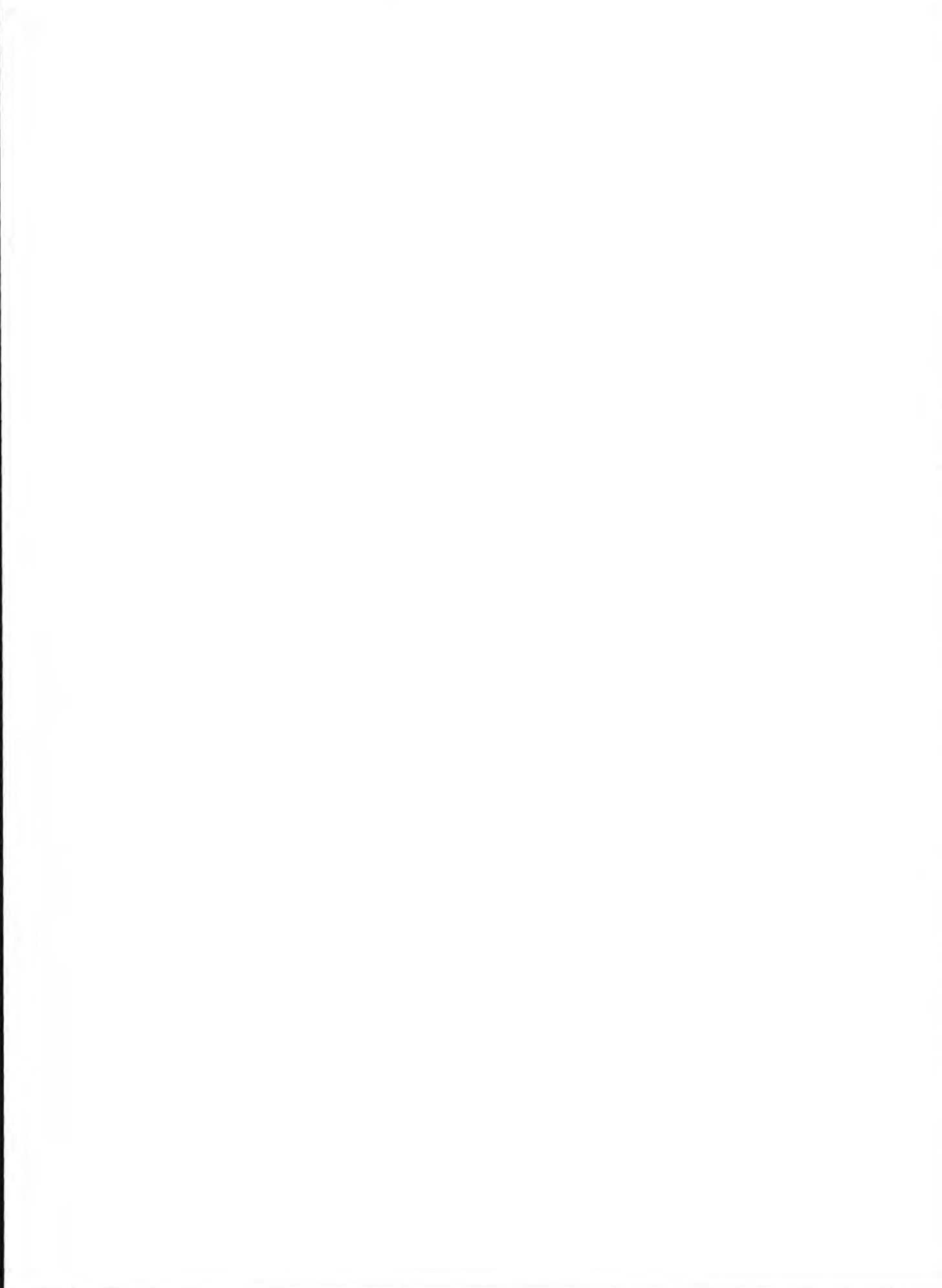

### AC BUS 2 SPECIAL TESTS

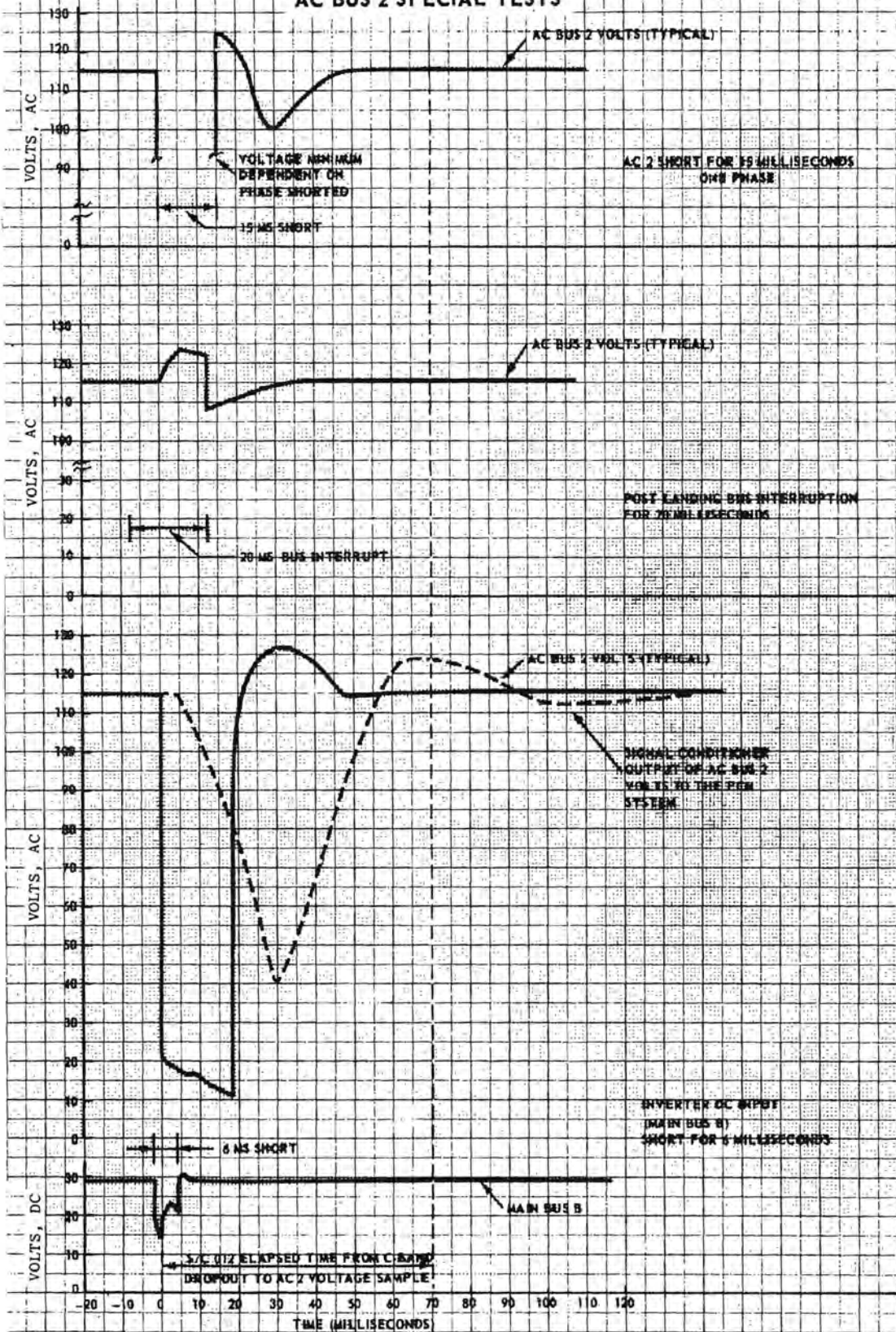

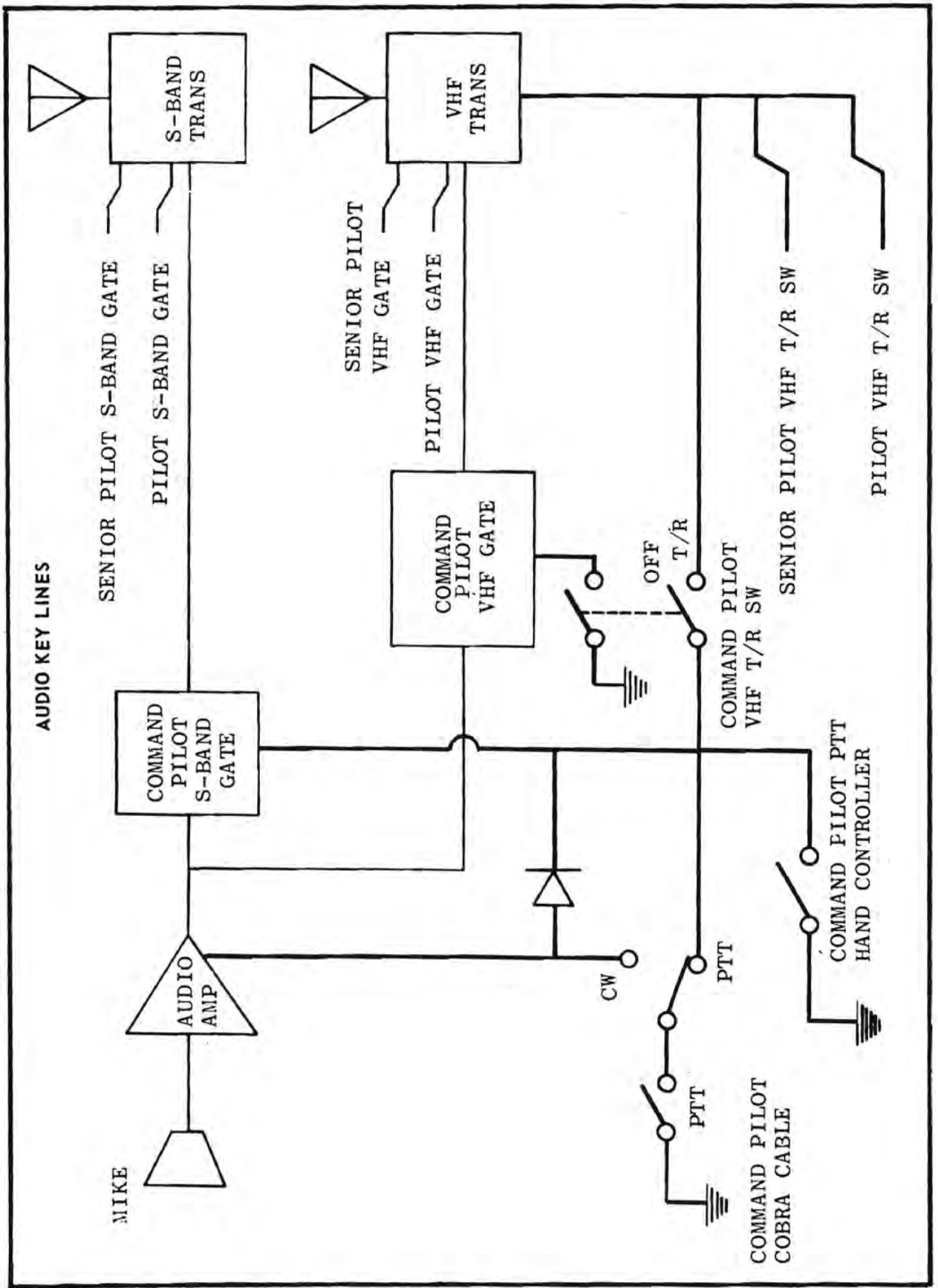

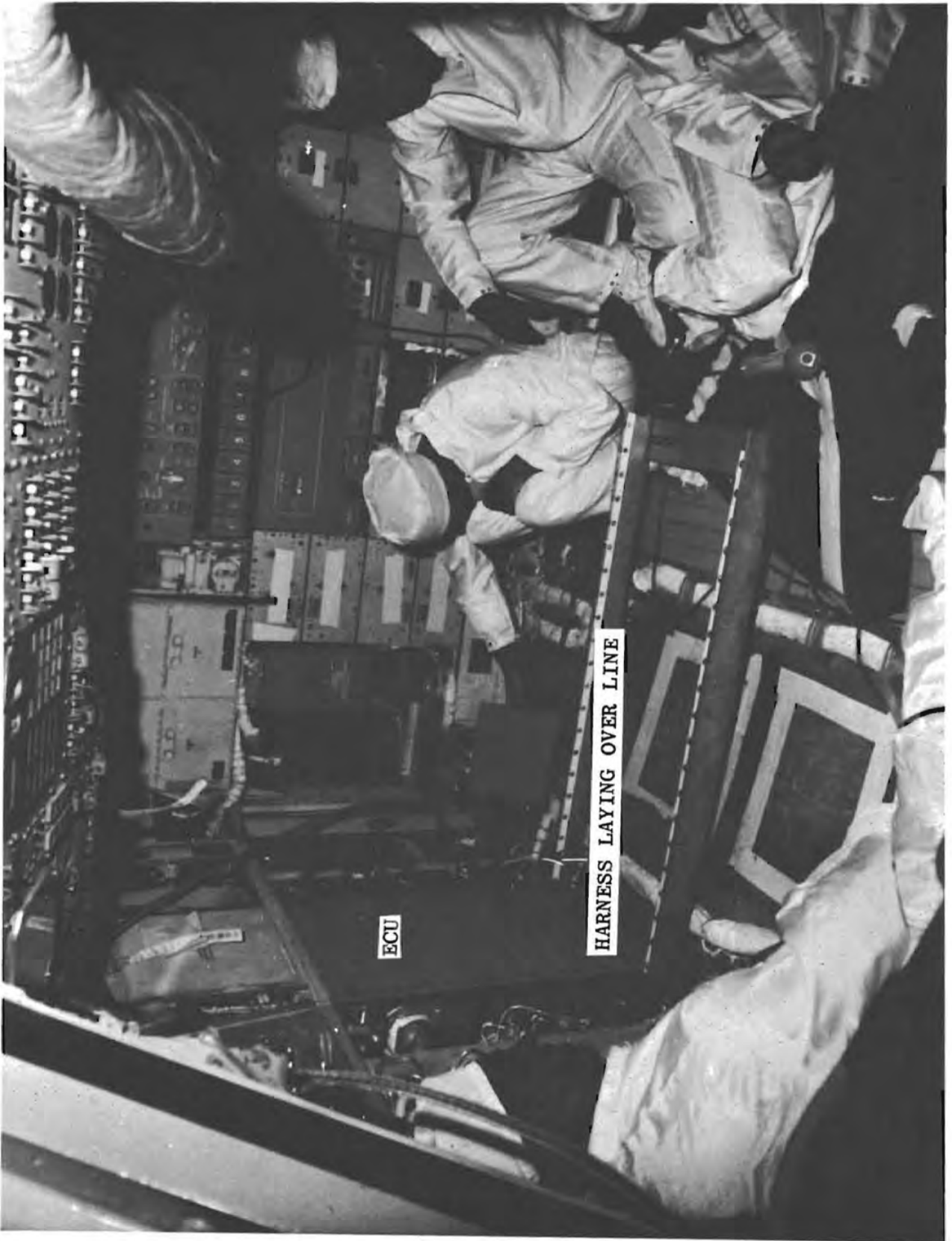

ECU

HARNES LAYING OVER LINE

ENVIRONMENTAL CONTROL SYSTEM INSTRUMENTATION HARNESSES BEFORE ACCIDENT.



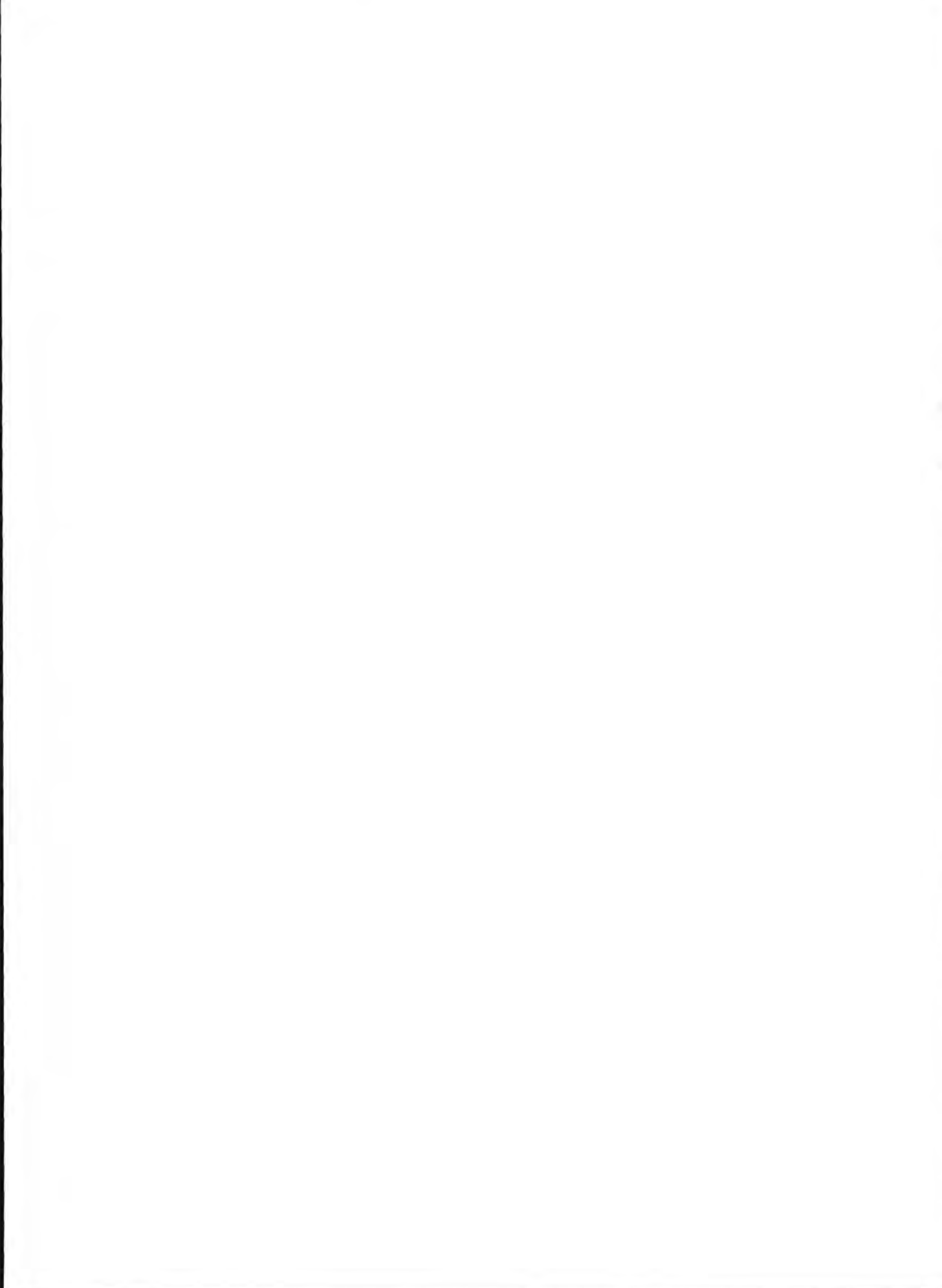

# ENVIRONMENTAL CONTROL SYSTEM INSTRUMENTATION HARNESS WIRING IDENTIFICATION

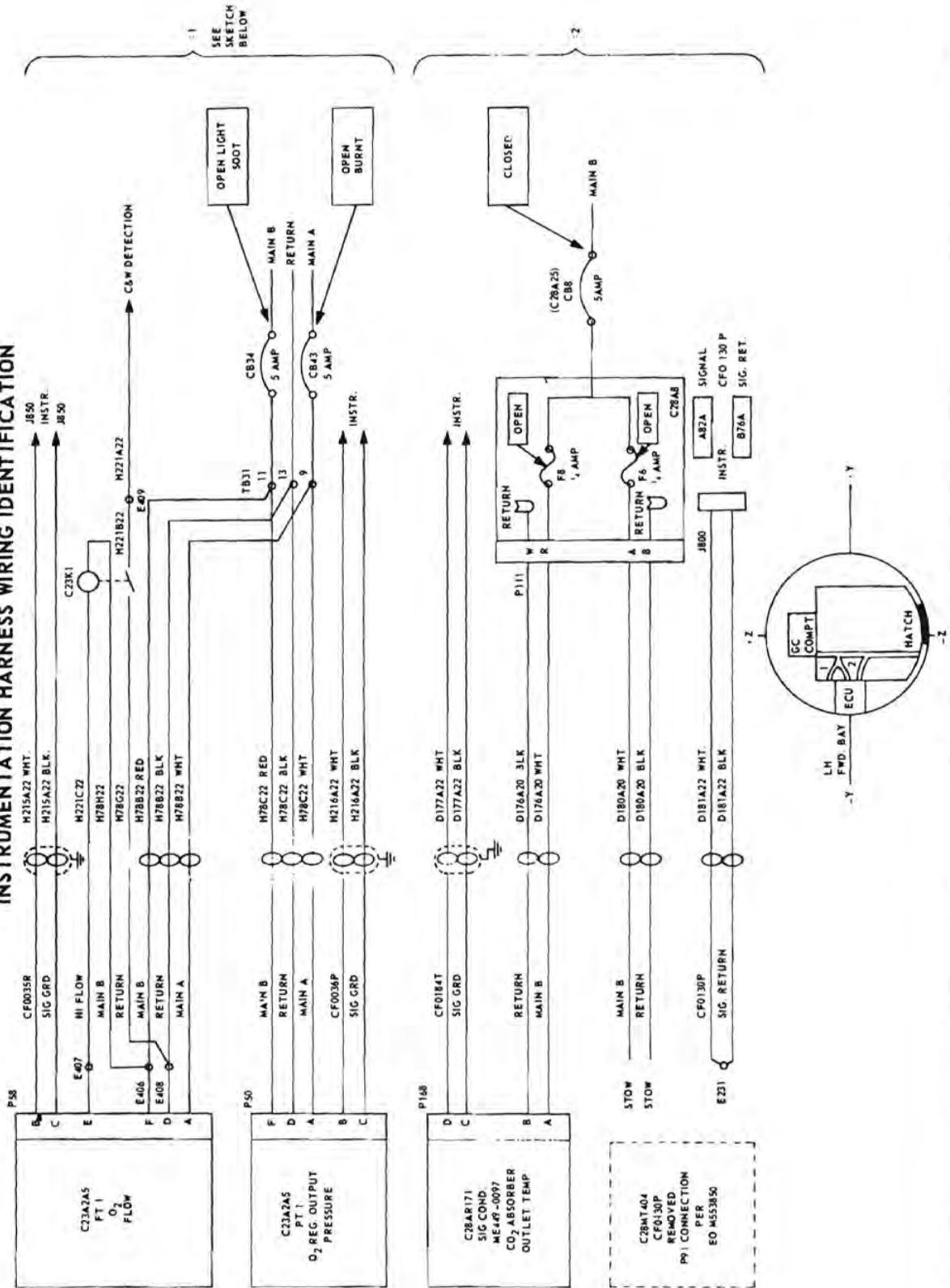

This page left blank intentionally.

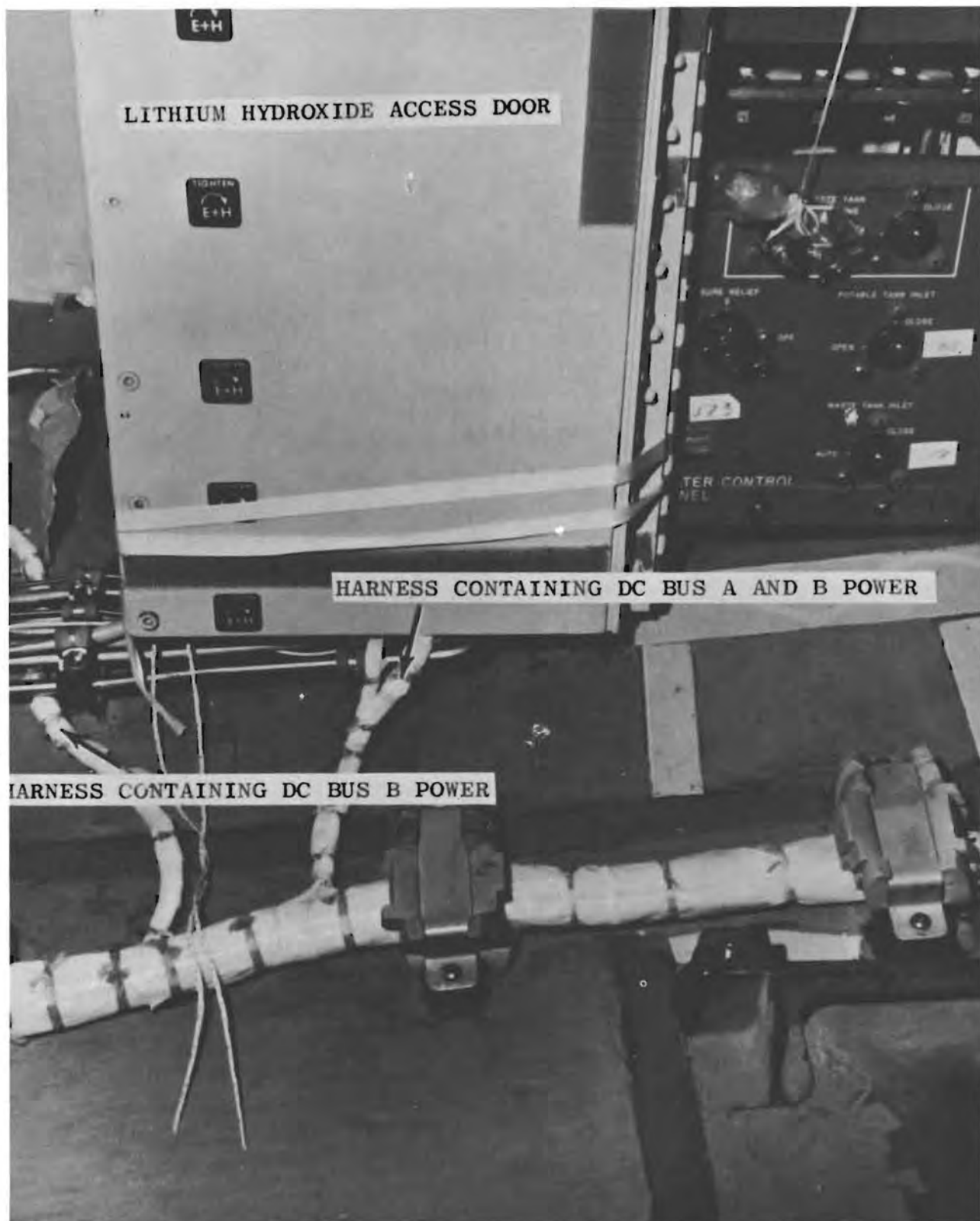

SPACECRAFT 014 ENVIRONMENTAL CONTROL SYSTEM INSTRUMENTATION  
HARNESS





ENVIRONMENTAL CONTROL SYSTEM INSTRUMENTATION HARNESSES  
AFTER ACCIDENT



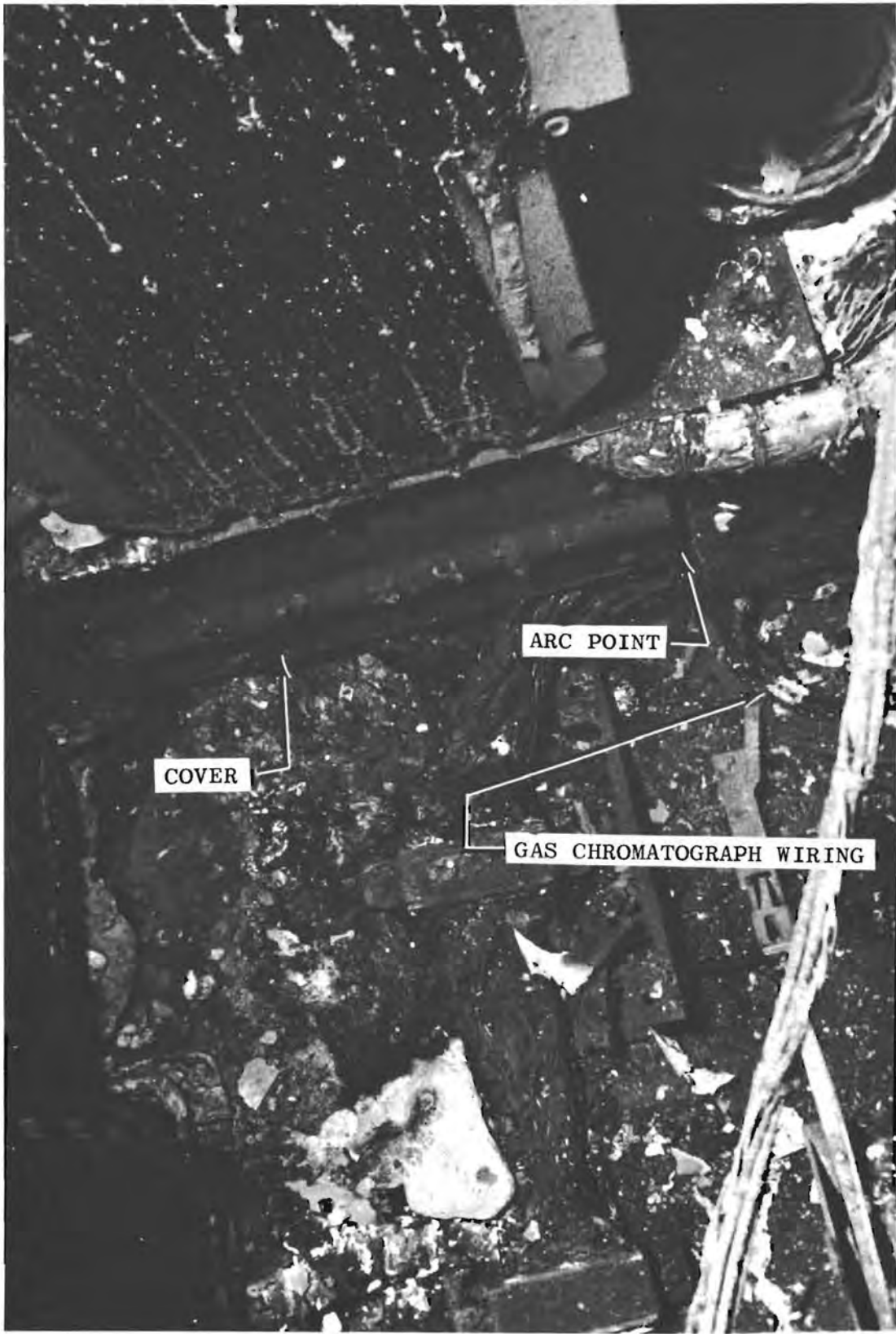

COVER OF PANEL C15-1A52





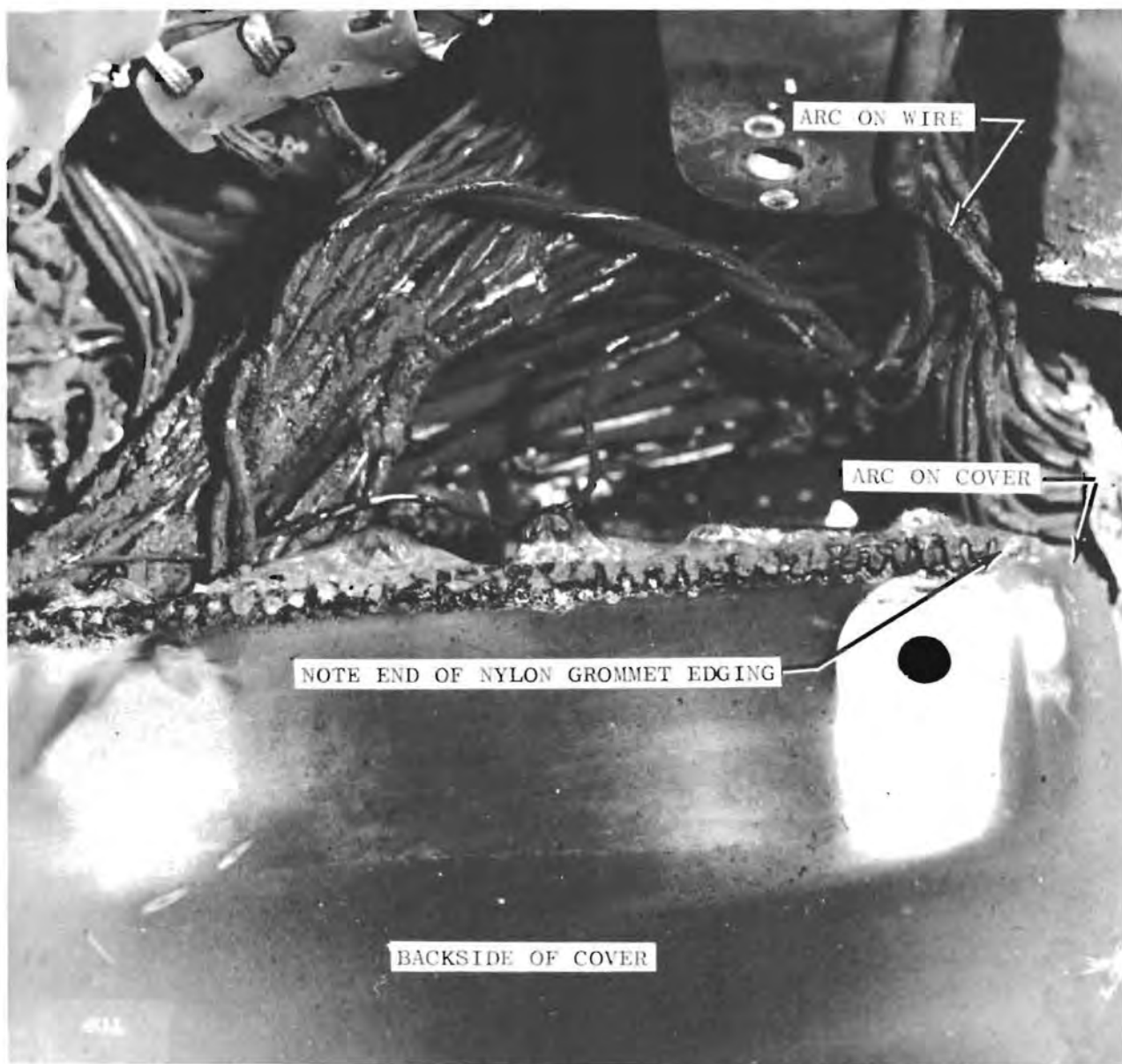

ARCED POINT ON WIRE AND COVER OF JUNCTION BOX C15-1A52



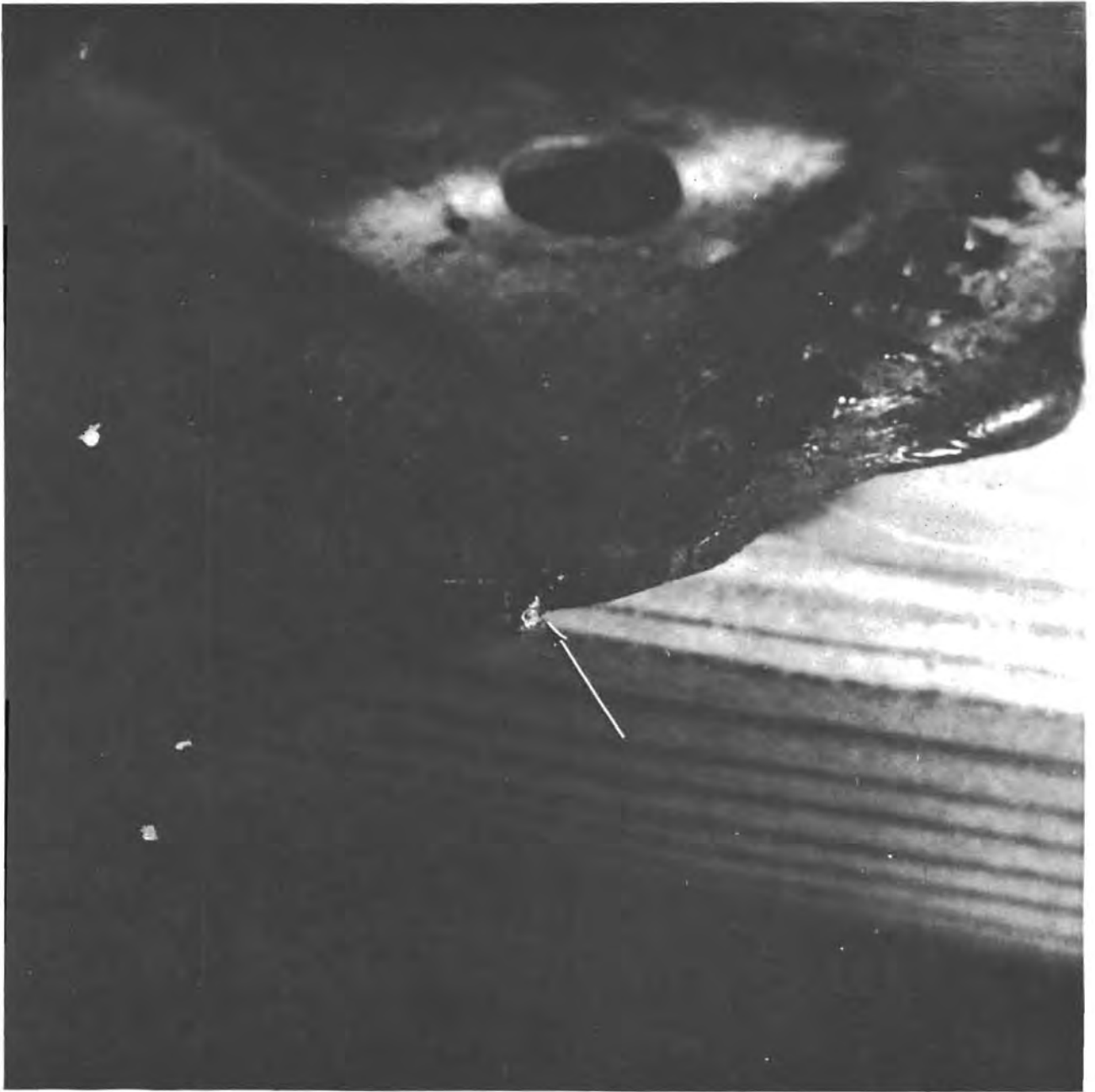

ARC POINT ON COVER OF JUNCTION BOX C15-1A52

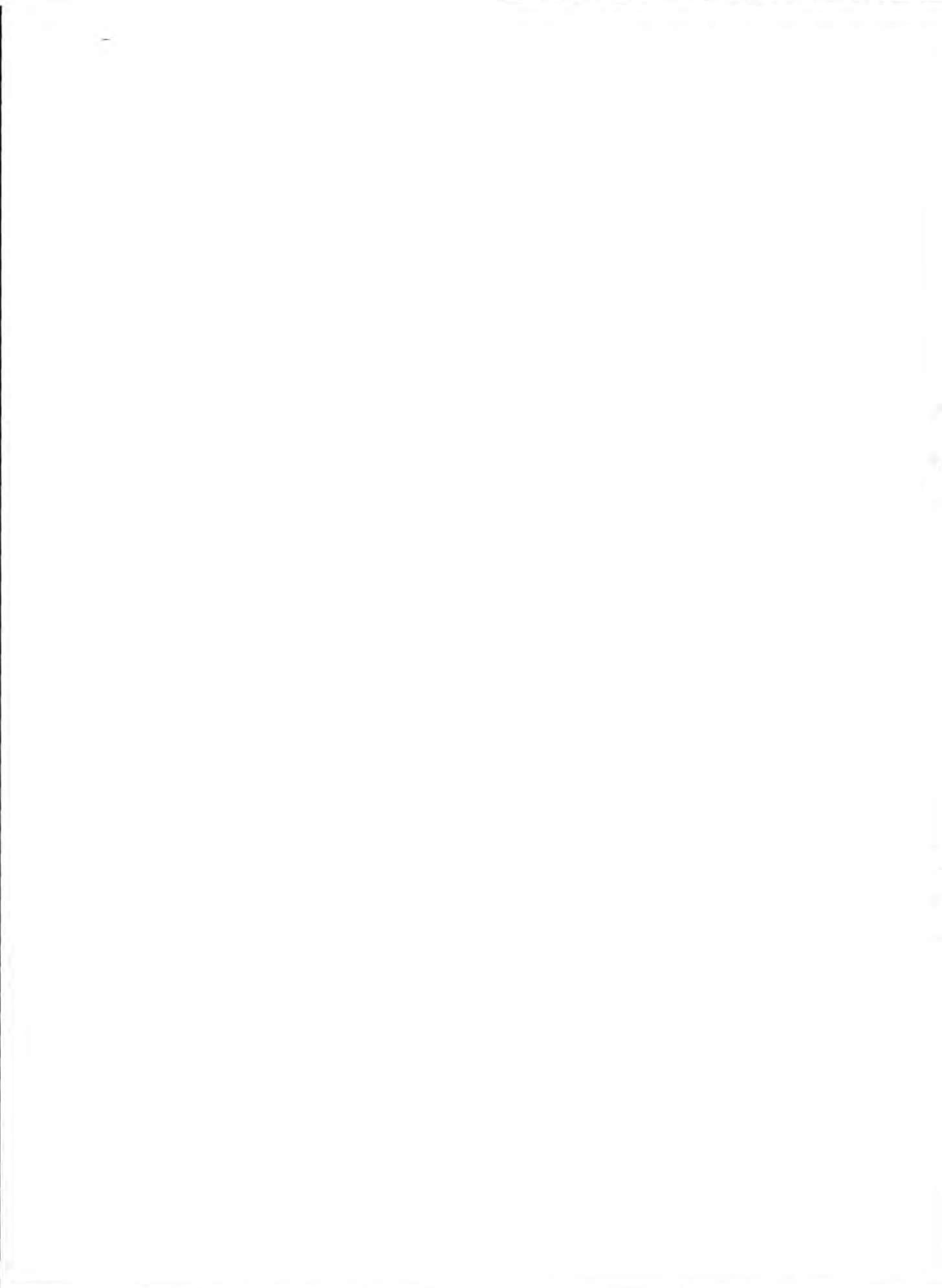



ARC POINT ON WIRE RELATED TO COVER OF JUNCTION BOX  
C15-1A52





ORIGINAL POSITION WAS SOMEWHERE  
ON THIS SHELF

ORIGINAL PHOTO OF GAS CHROMATOGRAPH  
CONNECTOR ON FLOOR ( NOTE: TWO SPOT TIES  
BLACKENED ON BIG HARNESS

UNDISTURBED LOCATION OF GAS CHROMATOGRAPH CONNECTOR







NOTE UNBLACKENED SPOT TIES  
PROTECTED BY GAS CHROMATO-  
GRAPH CONNECTOR

AREA UNDER GAS CHROMATOGRAPH





SIDE OF GAS CHROMATOGRAPH CONNECTOR WHICH PROTECTED SPOT TIES  
ON HARNESS ON FLOOR.



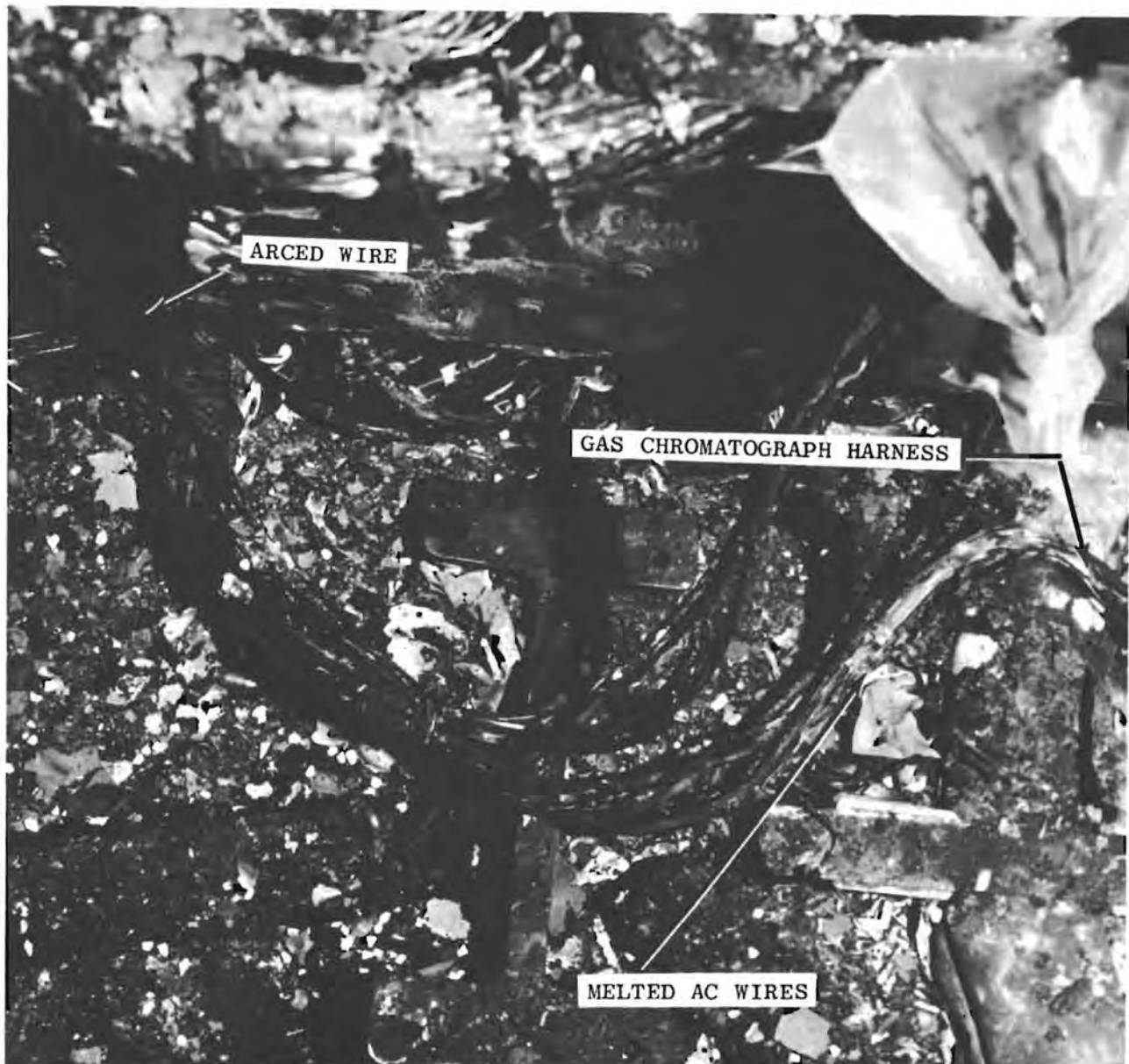

COPPER DROPLETS ON GAS CHROMATOGRAPH WIRES



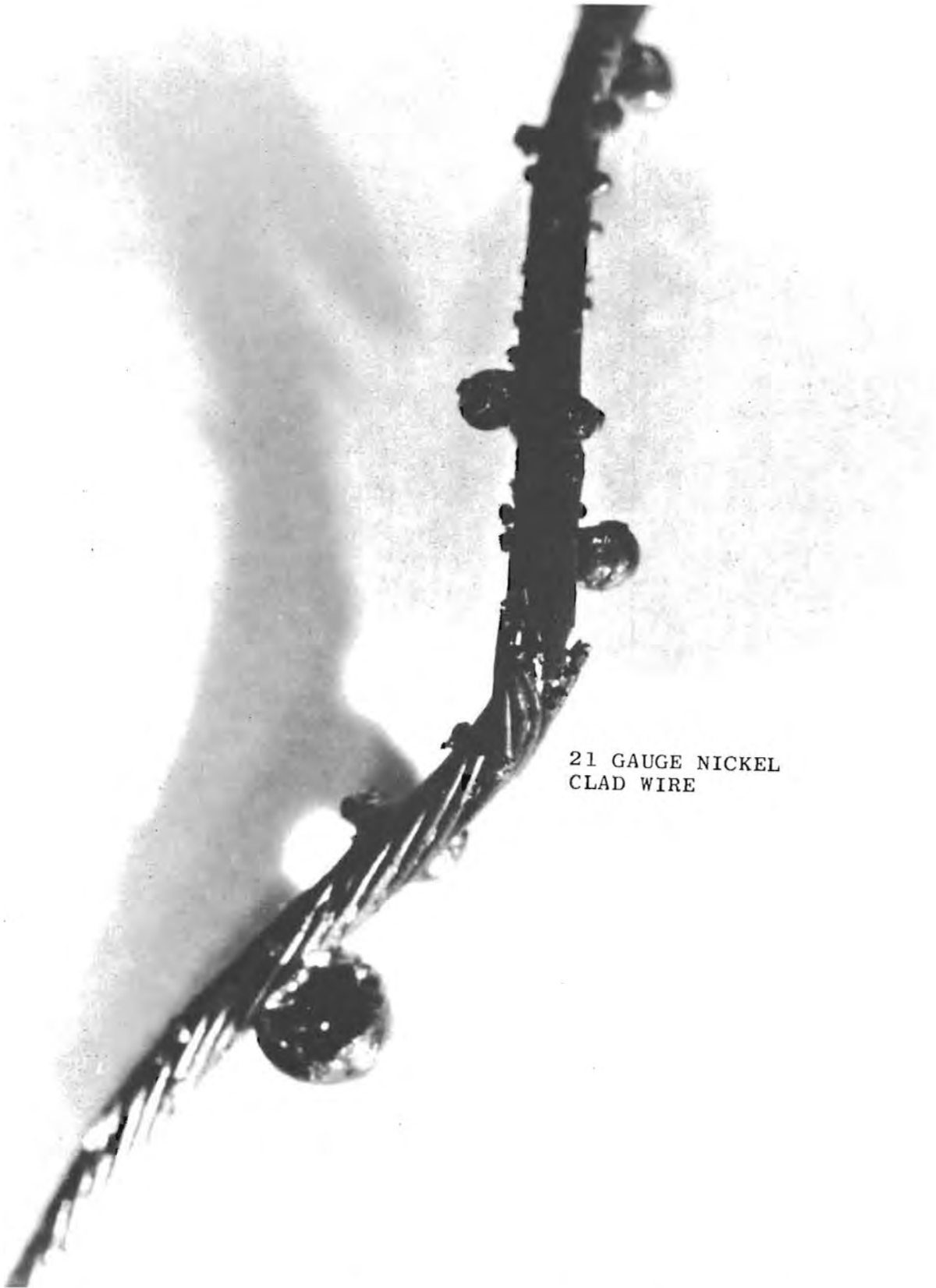

21 GAUGE NICKEL  
CLAD WIRE

COPPER FLOW AND NICKEL PIPE EFFECT ON GAS CHROMATOGRAPH AC WIRE

ENCLOSURE 18-37





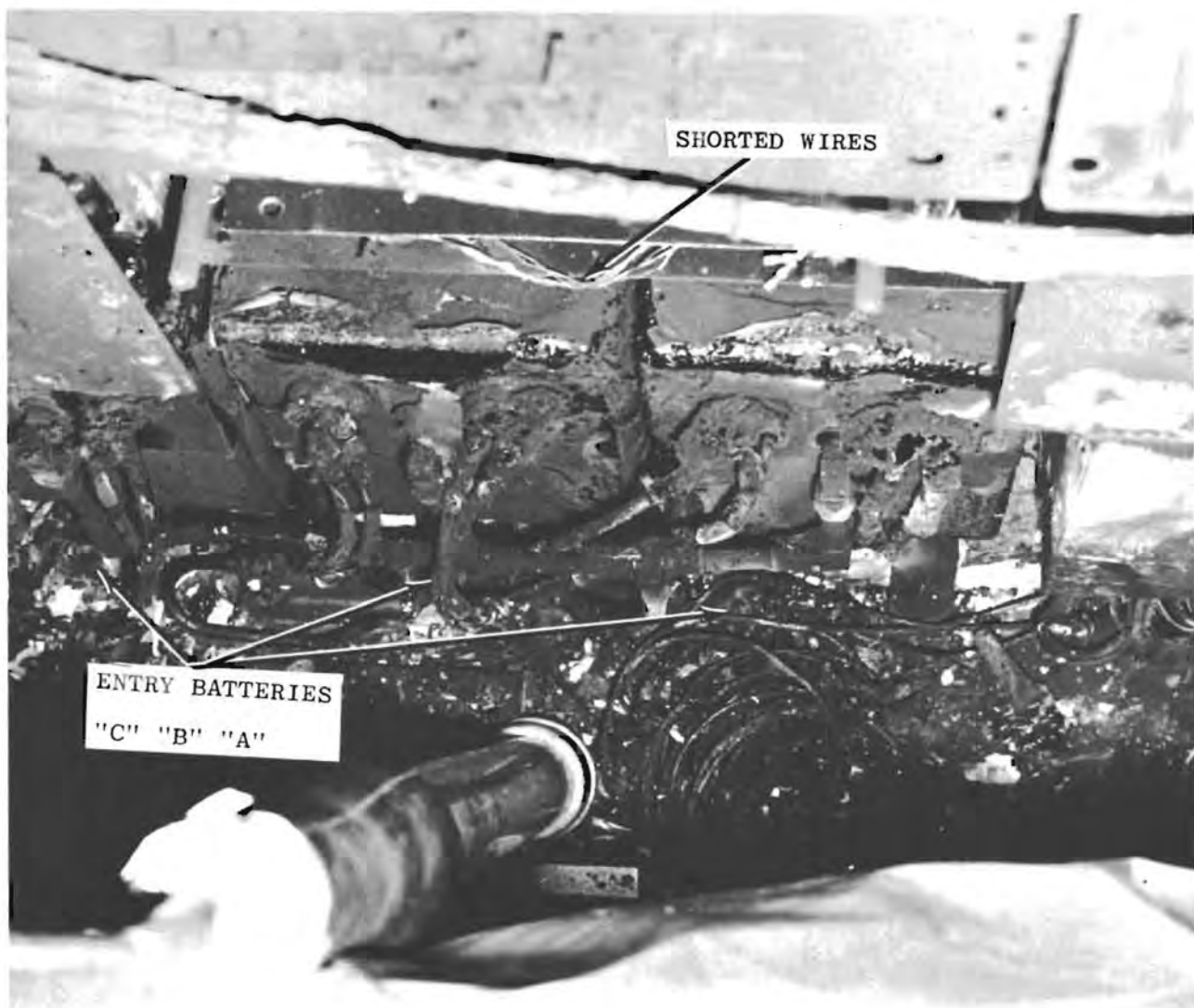

SHORTED DC WIRES ABOVE ENTRY BATTERIES



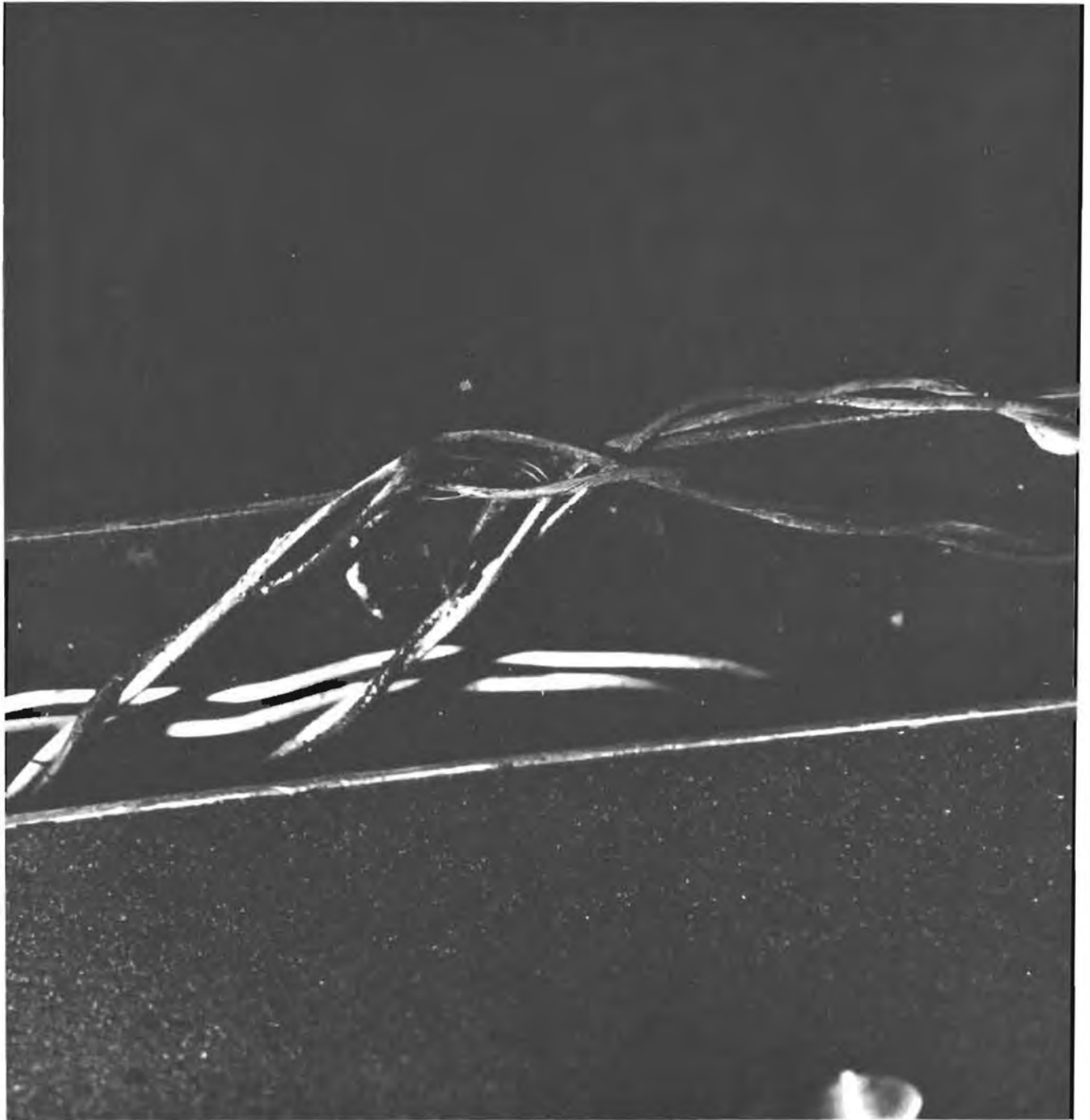

DETAIL OF SHORTED WIRES ABOVE BATTERIES





LOCATION OF CABIN FANS



MAIN DISPLAY CONSOLE PANEL NUMBER 8

SWITCH S-11 (SCS A&C ROLL)

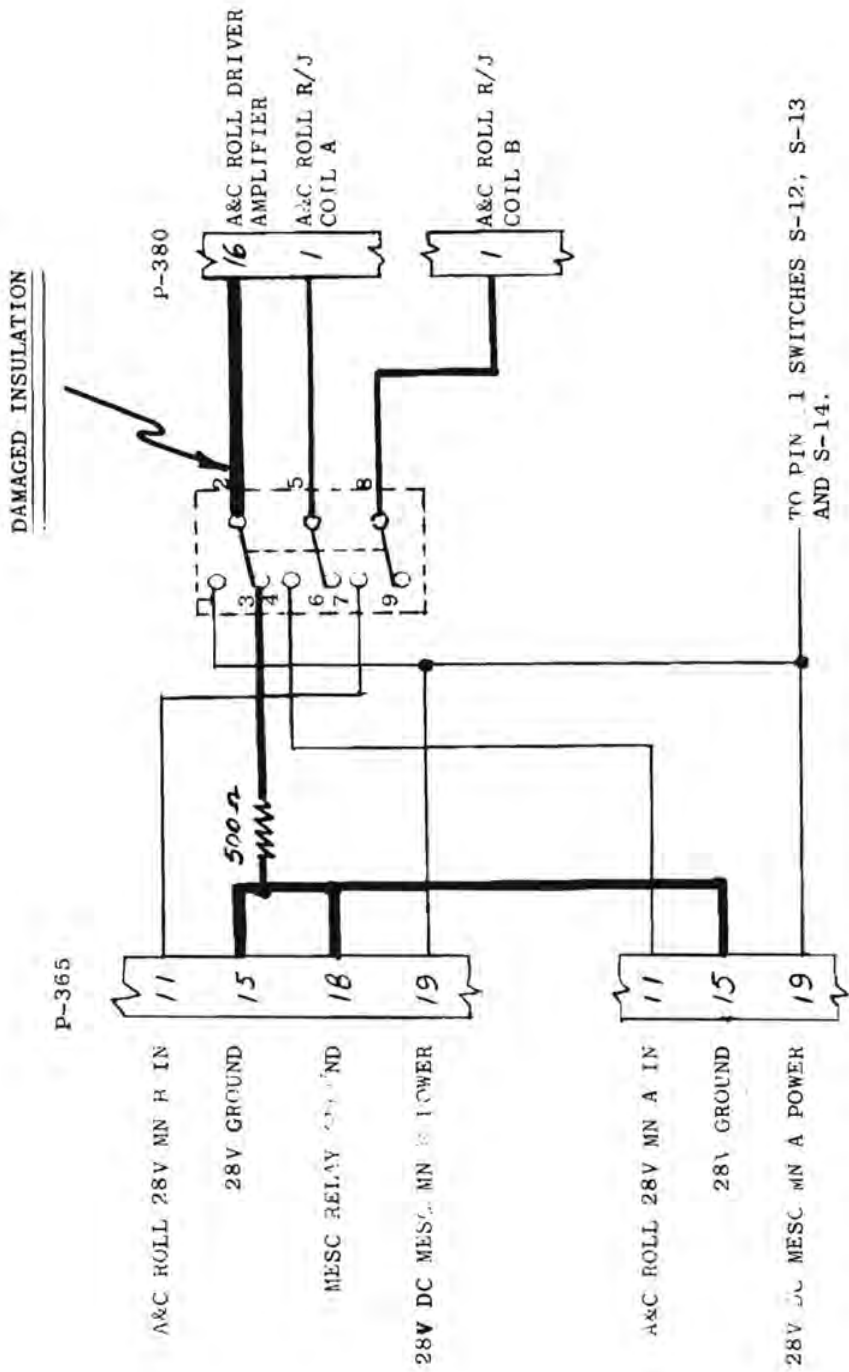

Enclosure 18-41: Main Display Console Panel Number 8 Switch S-11 Wiring



This page left blank intentionally.

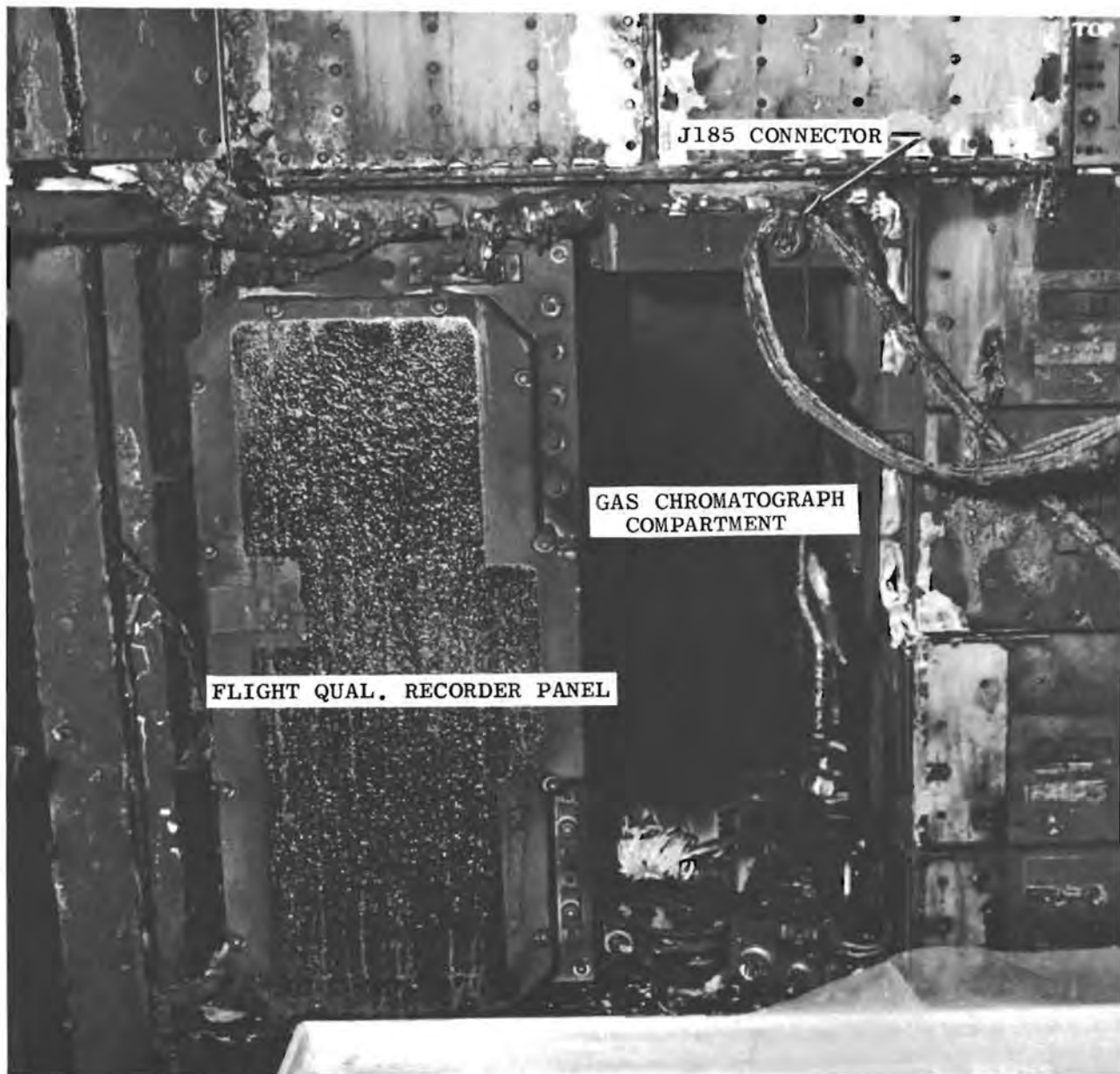

LOCATION OF OCTAPUS CABLE J-185 CONNECTOR



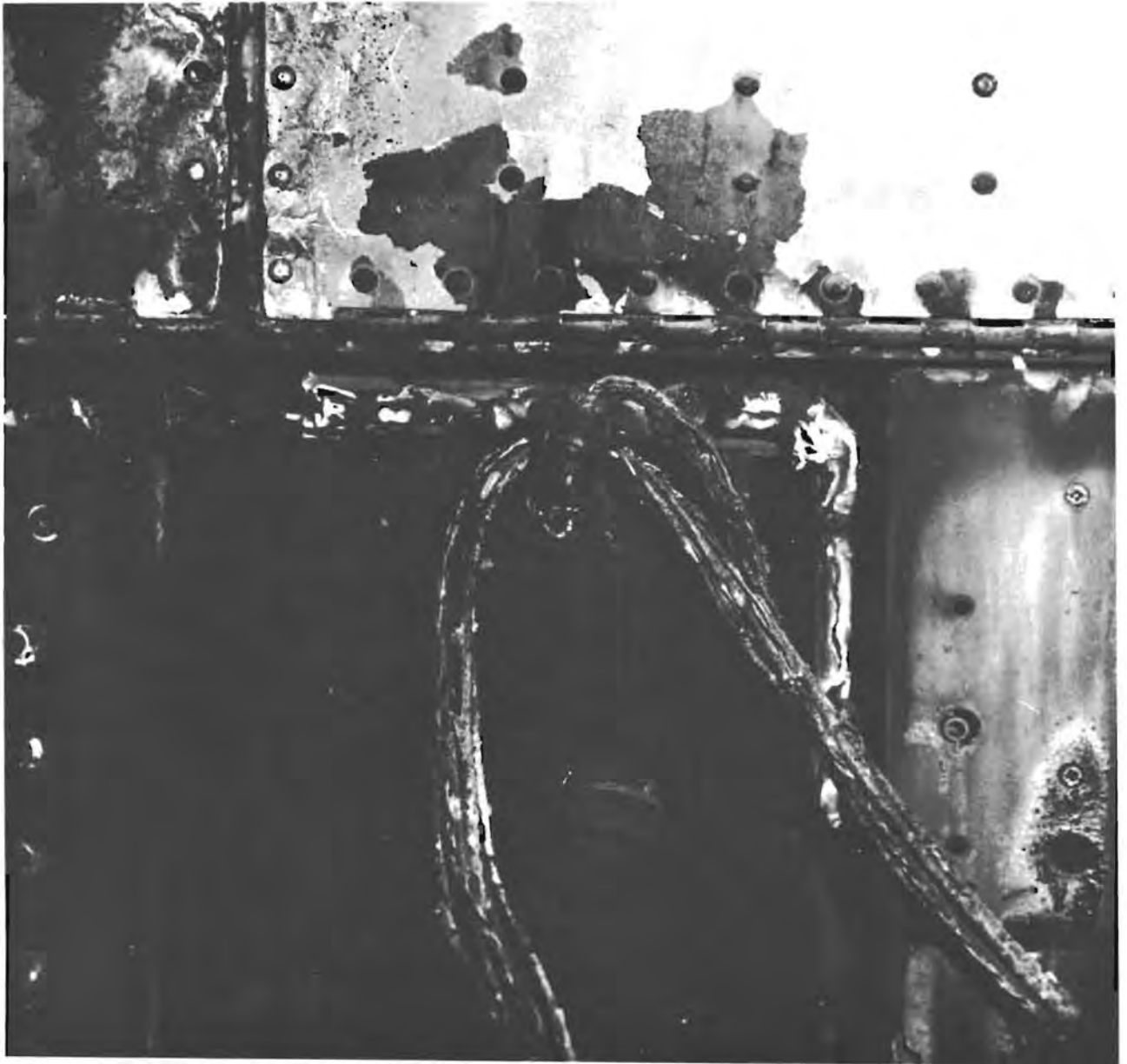

DETAIL OF J-195 CONNECTOR



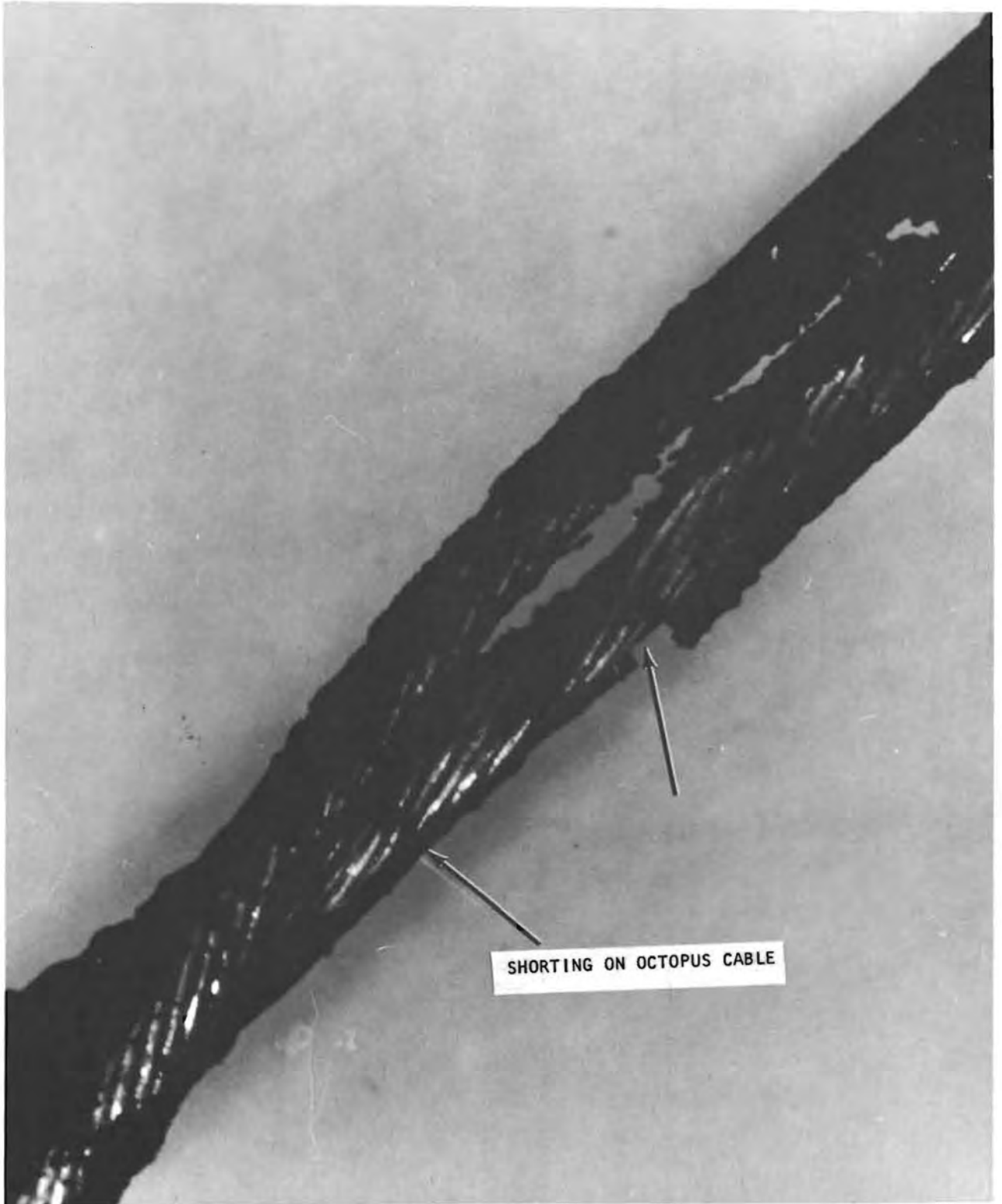

SHORTING ON OCTAPUS CABLE

ENCLOSURE 18-44



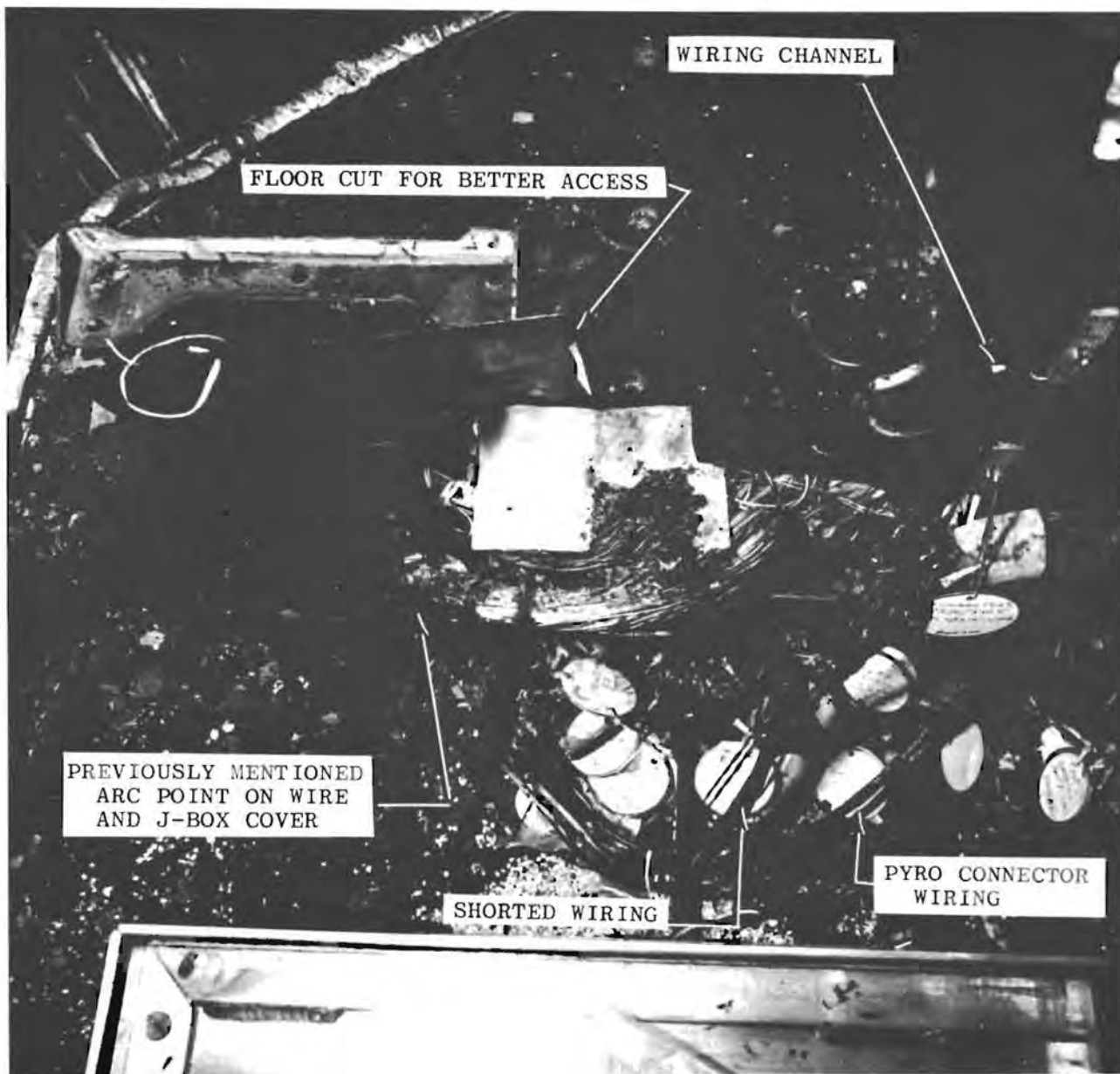

POWER HARNESS TO J-185 CONNECTOR





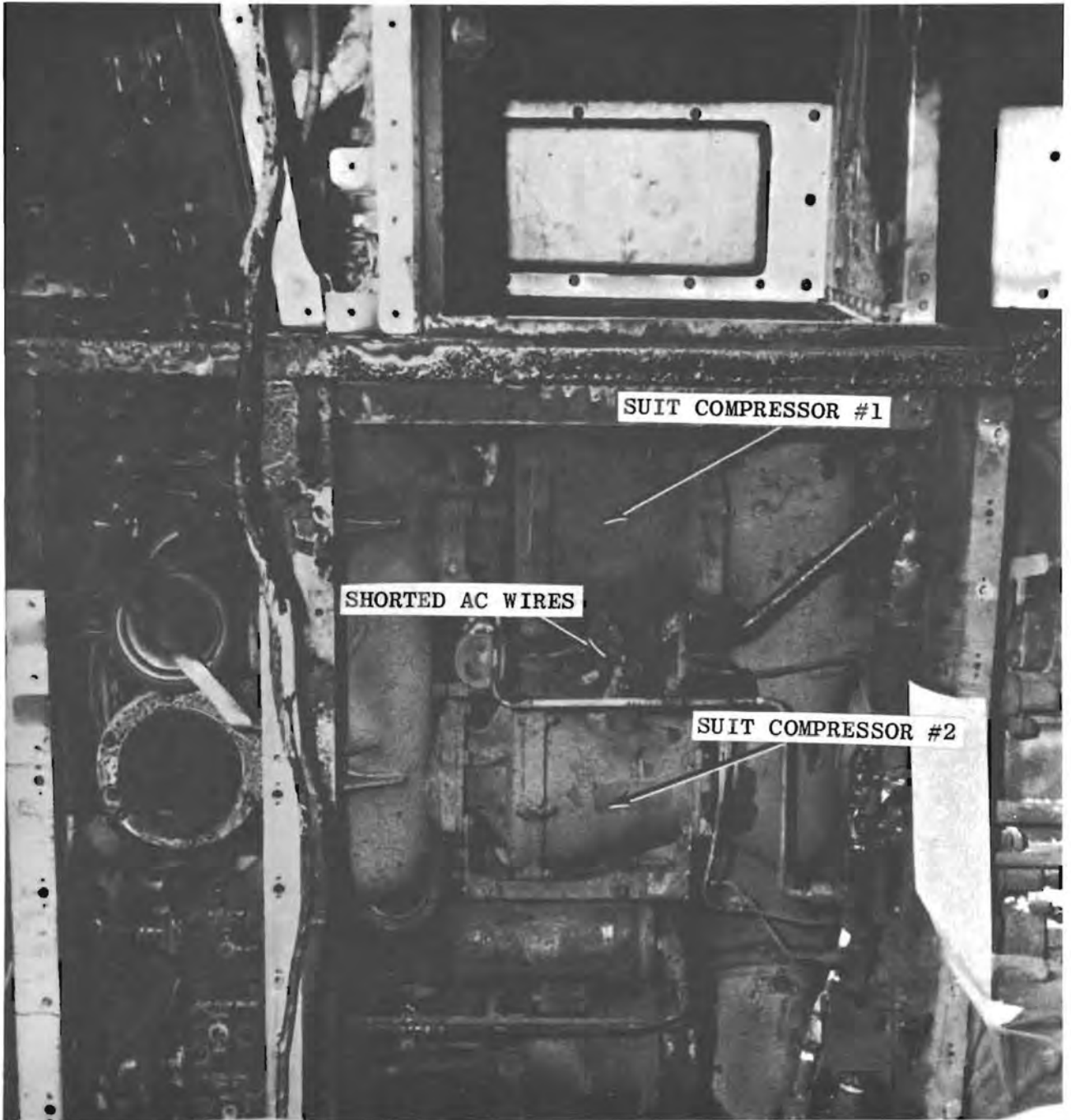

SUIT COMPRESSOR WIRING AFTER ACCIDENT



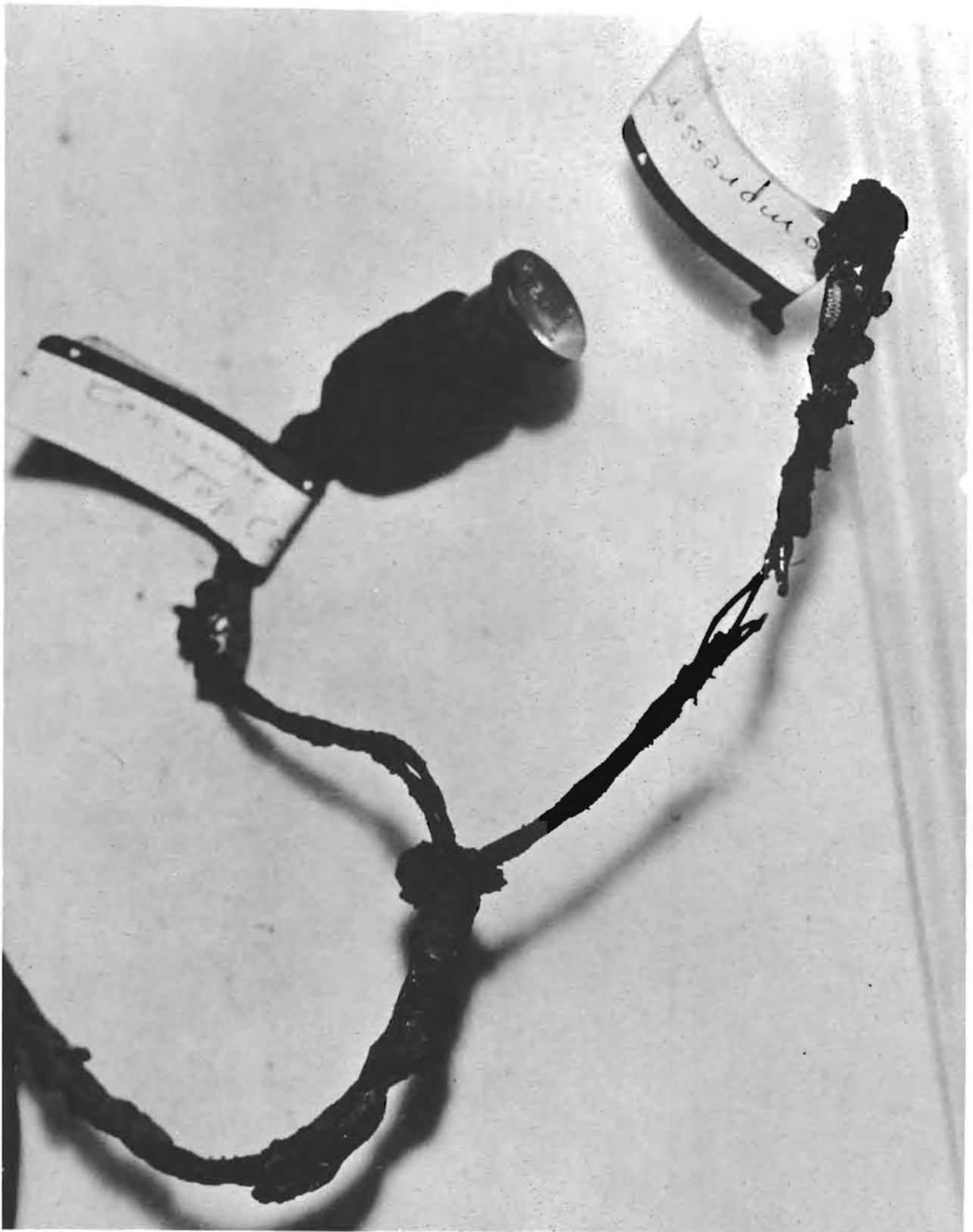

Enclosure 18-47



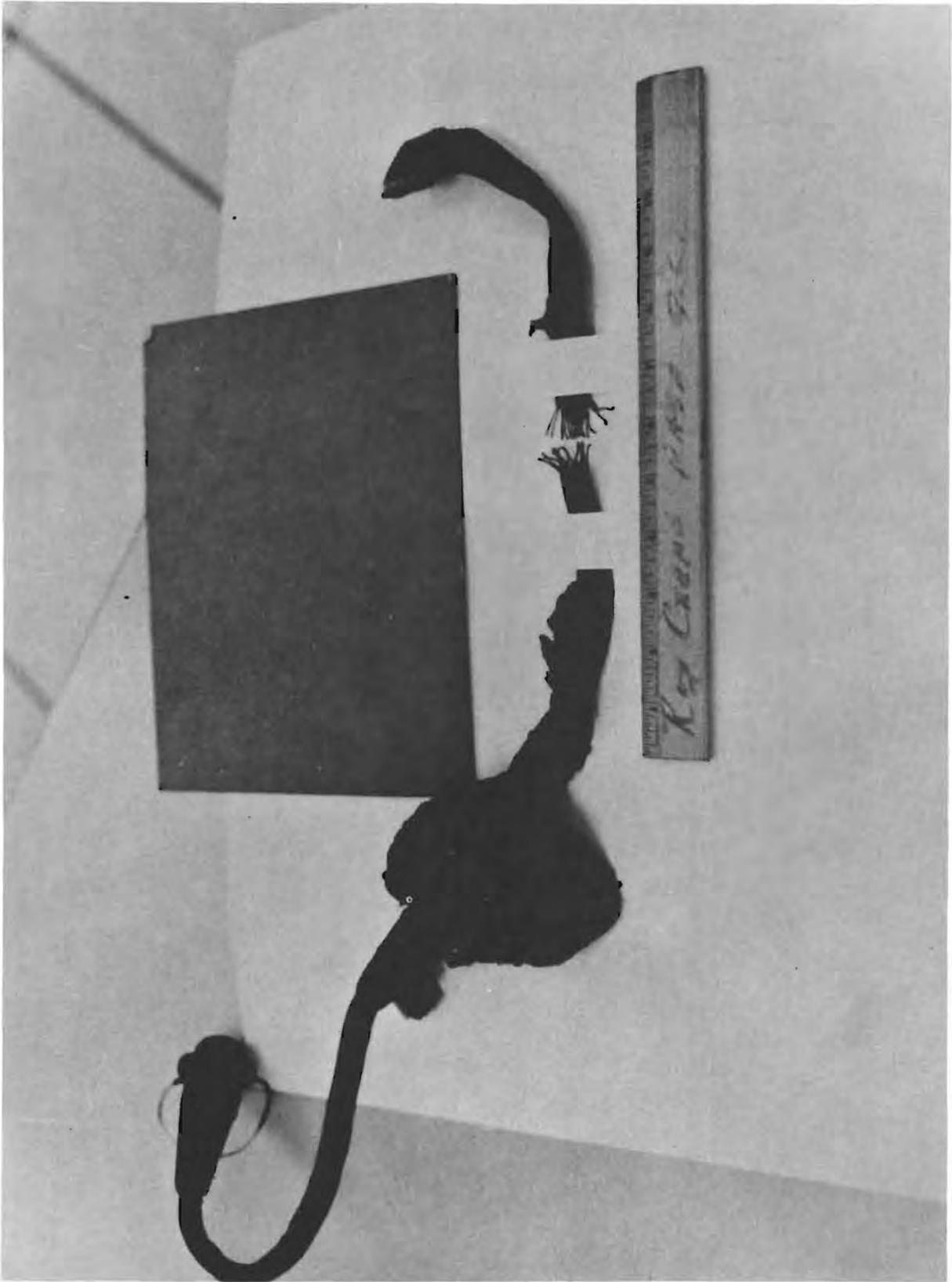

COMMAND PILOT'S SUIT WIRING



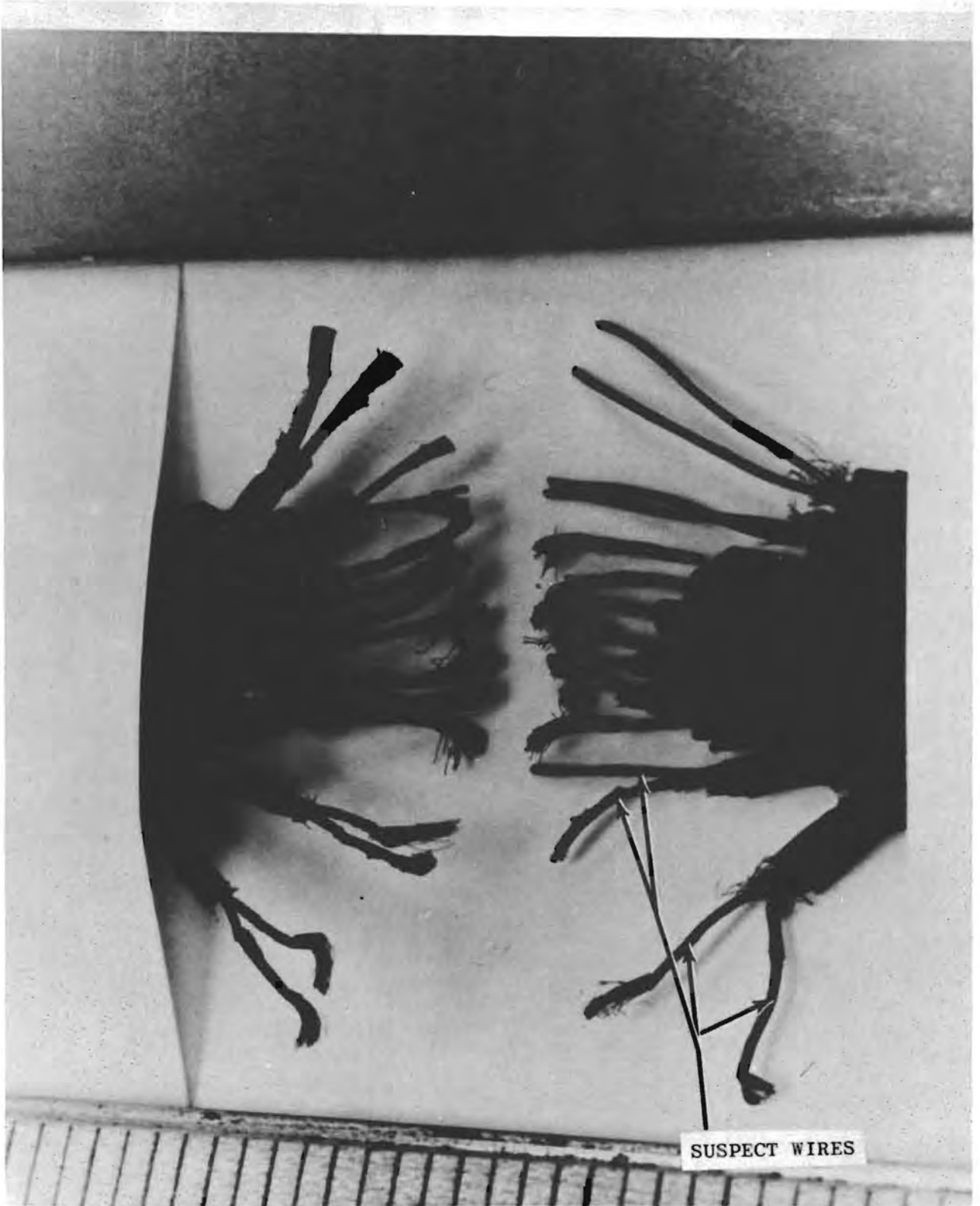

DETAIL OF COMMAND PILOT'S COMMUNICATION HARNESS

ENCLOSURE 18-49





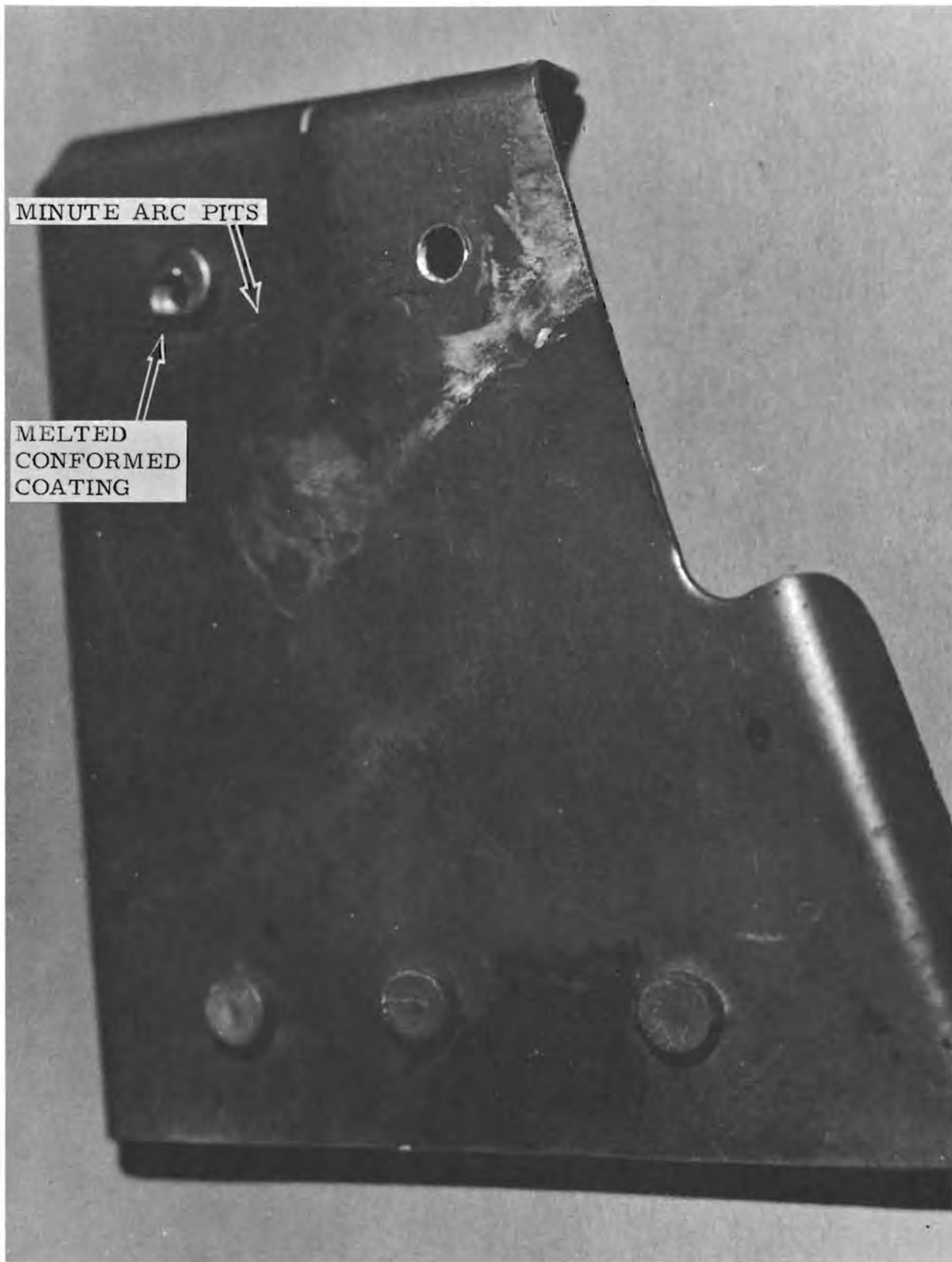

LOCATION OF SWITCH SII ON PANEL 8



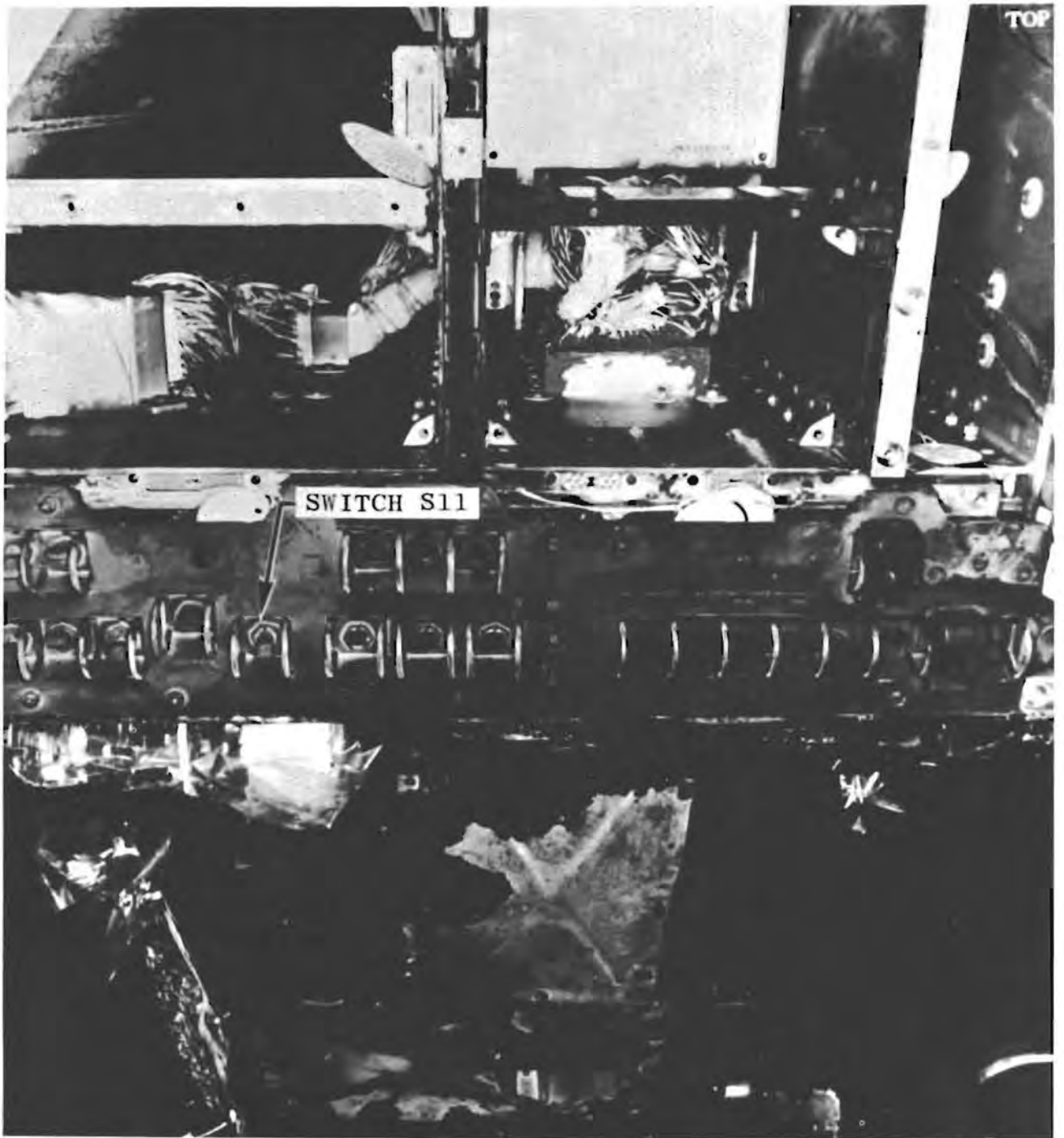

SHORT TO STRUCTURE BY TERMINAL OF SWITCH S11



STATUS OF INVESTIGATION ITEMS

ITEM NO.	ITEM	STATUS		ANALYSIS
		Investigation/Validation Action In Work	Validation Completed	
1	<p>Last voice from crew before fire 2330:03</p> <p>Baseline information only. No Analysis Summary required.</p>	3-3	3-14	<p>Did Not Cause Accident 3-14</p> <p>May have Contributed to Accident</p> <p>Bell Labs preliminary report received. Information of significance will be covered under appropriate items.</p>
2	<p>Noise on S-Band voice channel 2330:39.5 to 2330:58.5</p>	3-20	3-31	<p>3-31</p> <p>Bell Labs and MSC preliminary reports received. Their determination on these noises is inconclusive. However, the sounds were similar to those of tapping and brushing a microphone.</p> <p>ITEM CLOSED</p>
3	<p>IMU gimbal angle data indicates movement: 2330:39 to 2330:44, 2330:54.9 2331:00 to Loss of Data</p>	3-3	3-21	<p>3-21</p> <p>Data have been reviewed to determine if correlation of definitive movement can be established from gimbal torque motor signals. It was determined that no repeatability or consistency could be established other than gross indications of motions.</p> <p>ITEM CLOSED</p>
4	<p>Ground DC power supply number 2 shows a 4 amp increase for a one second sample 2326:30.5</p>	3-3	3-16	<p>3-16</p> <p>3-17</p> <p>An analysis of the data has been completed. It has been concluded that power supplies A and B may have momentarily shifted their shared loads or another load may have been added at this time. Considering the time, it has been concluded that this event could not have contributed to the cause of the accident.</p> <p>ITEM CLOSED</p>

STATUS OF INVESTIGATION ITEMS

ITEM NO.	ITEM	STATUS		ANALYSIS	
		Investigation/Validation Action In Work	Validation Completed	Did Not Cause Accident	May have Contributed to Accident
5	Gas chromatograph output starts movement from this time to loss of data 2330:50	3-5	3-20	3-21	The gas chromatograph (GC) was not installed in S/C 012 at the time of the accident. It has been determined, however, that the GC cable acted as an electromagnetic radiation detector. Changes in the GC data trace are an indication of changes of state in the Command Module.
6	VHF-FM video drops out for 30 milliseconds 2330:54.85	2-10	2-10	2-10	ITEM CLOSED Tests conducted showed that the received video signal will drop out if the AC supply drops to less than 50 volts or the DC supply drops to less than 6.5 volts for a period of 15 to 20 milliseconds. This is an effect of an AC bus 2 power interruption.
7	AC bus 2 voltages transient on all three phases 2330:54.85	3-20	4-1	4-1	ITEM CLOSED The AC voltage transient appeared as a rise of 5 to 8 volts for one data sample. Testing has determined that a momentarily interruption of bus B DC power to inverter 2 will cause this type of AC transient.
8	C-band transponder drops to zero volts for two seconds 2330:54.85 to 2330:56.9	2-10	2-10	2-10	ITEM CLOSED AC drop out for very short intervals of time causes the C-Band transponder to go to a protective mode. Normal recovery time is approximately 1.7 seconds. This is an effect of an AC bus 2 power interruption.

STATUS OF INVESTIGATION ITEMS

ITEM NO.	ITEM	STATUS		ANALYSIS	
		Investigation/ Validation Action In Work	Validation Completed	Did Not Cause Accident	May have Contributed to Accident
9	O <sub>2</sub> flow rate increases to measurement limit 2330:59.4	2-20	3-20	3-20	
		Telemetered data and engineering analysis of failure modes and circuitry, and an inspection of the flow sensor, leads to the conclusion that the high oxygen flow indication was valid, and that there was no malfunction of the sensor and/or associated wiring prior to the crew report of fire.			
10	Voice data "fire" 2331:04.7  Baseline information only. No Analysis Summary required.	3-21	3-27	3-27	
		Bell Labs and MSC preliminary reports received. Details of their analyses are contained in Section C-7 of the Panel 18 Final Report.			
11	Witnesses report bright glow moving from left to right after fire call  Baseline information only. No Analysis Summary required	2-13	2-14	3-17	
		A TV simulation test was performed utilizing S/C 008 Video tape playback were shown to the primary witnesses to verify their observation and time correlations, and no changes in statement resulted. The only positive summary statement is that after the fire call observation of the TV monitor showed flame progressing inside the crew compartment from the left corner of the porthole to the upper right area. ITEM CLOSED			
12	Data indicates the initial cabin temperature increase at 2331:06.4	2-14	4-1	4-1	
		Test conducted by the transducer's vendor (AIResearch) showed that the sensor response time was approximately 300 milliseconds. It is concluded that the time of cabin temperature rise is accurate to within ±1 second. ITEM CLOSED			



STATUS OF INVESTIGATION ITEMS

ITEM NO.	ITEM	STATUS		ANALYSIS	
		Investigation/Validation Action In Work	Validation Completed	Did Not Cause Accident	May have Contributed to Accident
13	Cabin pressure increase began at 2331:06.818 (battery pressure transducer)	2-10	2-14	2-14	
	Response time of the transducer has been determined. Response time plus measurement sampling rate defines the accuracy of this data to be within ± 100 milliseconds.				
					ITEM CLOSED
14	Cabin pressure increase began at 2331:08.417 (measurement CF0001P)	2-10	2-14	2-14	
	Response time of the transducer has been determined. Because this measurement is sampled only once per second, the battery pressure transducer (Item 13) should be used for cabin pressure data.				
					ITEM CLOSED
15	IMU gimbal angle data shows ramp starting at approximately 2331:10	2-10	2-10	2-15	
	The IMU gimbal ramp is attributed to an increase in Command Module pressure. This data has been substantiated by data obtained during the second vacuum chamber test on Spacecraft 012 and on special tests performed on Spacecraft 008 at MSC.				
					ITEM CLOSED
16	Entry battery B transferred to Main Bus B 2331:12.4	2-10	2-10	2-10	
	Two ground and six PCM measurements showed that the entry battery B was transferred to the Main Bus B. Also post test investigation substantiated the position of switch S-10 on panel 22 which is indicative of Pilot action. Refer to Item 17 for corollary information on Battery A.				
					ITEM CLOSED

STATUS OF INVESTIGATION ITEMS

ITEM NO.	ITEM	STATUS		ANALYSIS	
		Investigation/ Validation Action In Work	Validation Completed	Did Not Cause Accident	May have Contributed to Accident
17	Entry battery A transferred to Main Bus A 2331:13.6	2-10	2-10	2-10	Four PCM measurements showed that the Entry Battery A was transferred to Main Bus A. This was further substantiated by the post test inspection of switch S-9 on panel 22 which is indicative of Pilot action.
					ITEM CLOSED
18	Master caution warning light came on 2331:14.7	2-10	2-10	2-10	This light was the result of a high oxygen flow rate indication. Whenever the oxygen flow rate increases to its maximum and stays at a maximum transducer saturated level for 15 seconds, the master alarm will come on.
					ITEM CLOSED
19	Temperature of oxygen supply began to increase 2331:16.0	2-10	2-14	2-14	Post test observations indicate that loss of pressure suit circuit integrity occurred in the Command Pilot's pressure suit and/or return hose. Such an opening would allow warm cabin air to be drawn into the suit compressor. The CO <sub>2</sub> absorber outlet temperature indicates that the CO <sub>2</sub> absorber acted as a heat sink until this time, when it and the suit manifold temperature began to increase.
					ITEM CLOSED
20	Momentary interruption in VHF-FM and S-Band data 2331:17.398 to 2331:17.659	2-10	3-10	3-10	This loss of data is attributed to soft short circuits occurring in the communications system wiring.
					ITEM CLOSED

STATUS OF INVESTIGATION ITEMS

ITEM NO.	ITEM	STATUS		ANALYSIS	
		Investigation/Validation Action In Work	Validation Completed	Did Not Cause Accident	May have Contributed to Accident
21	Biomed recorder timing trace inspection for DC dropout.	3-3	3-16	3-16	
		Tests showed that the timing trace amplitude changes were caused by imperfections and dust on the tape. There were no interruptions indicative of a short on DC bus B, on Biomed recorder data from the accident.			
22	Additional (seven) gas chromatograph data variations 2204:45 to 2255:43	3-6	3-16	3-16	
		An analysis of the data at these times has been conducted and correlations with other systems changes were seen. It has been concluded that the gas chromatographs cable acted as an electromagnetic radiation detector.			
23	Loss of all communications data 2331:21.0 to 2331:22.42	2-14	3-10	3-10	
		This is due to the burning and shorting of wire harnesses during the fire, attributed to a loss of power or loss of a coax cable.			
24	MTVC Pitch Rate Command observed at 2330:54,847	2-14	2-23	2-23	
		This happened at the same time as the AC Bus 2 transient. A re-analysis disclosed this was a one bit change in the data which occurred frequently. No significance is therefore attributed to this item.			

ITEM CLOSED

ITEM CLOSED

ITEM CLOSED

ITEM CLOSED

STATUS OF INVESTIGATION ITEMS

ITEM NO.	ITEM	STATUS		ANALYSIS	
		Investigation/Validation Action In Work	Validation Completed	Did Not Cause Accident	May have Contributed to Accident
25	Senior Pilot suit flow dropped to lower limit then returned to normal flow indication 2331:09.6 to 2331:11.9	3-6	4-1	4-1	
	It is inferred that the Senior Pilot disconnected his suit inlet hose for emergency egress (Reference Item No. 102).				
26	O <sub>2</sub> surge tank pressure started to decrease 2331:12.4	3-3	3-20	3-20	ITEM CLOSED
	It is concluded that the oxygen surge tank pressure decay was the result of high O <sub>2</sub> flows into the suit loop.				
27	Command Pilot suit flow started fluctuating at 2331:12.9 and Senior Pilot suit flow started fluctuating at 2331:15.4	2-13	2-27	2-27	ITEM CLOSED
	Characteristic of suit flow indications with restricting caused by Command Pilot movements or physical activity. The time period for fluctuations in the Senior Pilot suit flow coincides with increase muscular activity indicated by physiological data.				
28	Suit compressor inlet temperature starts increasing 2331:13.2	2-13	2-14	2-14	ITEM CLOSED
	Post-test observations indicate that loss of pressure suit circuit integrity occurred in the Command Pilot's pressure suit and/or return hose. Such an opening would allow warm cabin air to be drawn into the suit compressor.				

STATUS OF INVESTIGATION ITEMS

ITEM NO.	ITEM	STATUS		ANALYSIS
		Investigation/ Validation Action In Work	Validation Completed	
29	RCS jet action, data questionable 2329:40	2-14	2-23	2-23 A more detailed analysis of the data during this period has been completed. The indicated RCS action was found to be erroneous.
30	Rotation controller output transient of 1.5% 2330:54.85	3-2	3-31	3-31 ITEM CLOSED This happened at the same time as the AC Bus 2 transient. Special tests have shown that the null output transients can be duplicated by a momentary interruption of AC Bus 2 phase A input power. This is therefore an effect of the AC Bus 2 transient.
31	Electrical short due to cold flow characteristics of Teflon wire insulation	2-24	4-1	4-1 ITEM CLOSED All wire bundles in the spacecraft which showed damage were carefully inspected for signs of arcing. Due to the considerable fire damage and the possibility that shorting could have been a result, evidence of Teflon "cold-flow" is considered inconclusive.
32	SCS roll rate oscillations starting at 2331:03.85	2-19	2-23	2-23 ITEM CLOSED Indicates movement in the command module during this period. Nothing more can be inferred from the data other than movement.

STATUS OF INVESTIGATION ITEMS

ITEM NO.	ITEM	STATUS		ANALYSIS
		Investigation/ Validation Action In Work	Validation Completed	
33	Launch Vehicle pitch and yaw accelerometers start oscillation 2331:04 to loss of data	2-14	2-15	2-15 No indications in data during cobra cable change (crew movement). Data shows slight oscillations starting at 2331:04 with maximum activity at 2331:20
34	Arcing noted on Junction Box cover plate	3-14	4-1	4-1 No positive identification has been made to indicate that this arc occurred prior to the fire. Burning noted in this area does not appear as severe as would be expected had the fire started due to this arc.
35	Suit differential pressure begins to increase 2331:06.4	2-13	3-20	3-20 The oxygen demand regulator senses cabin pressure. An increase in cabin pressure will cause the diaphragm of the regulator to be opened allowing oxygen flow into the suit loop.
36	Saturn I engine 8 anomaly 2052:23.039	2-22	3-31	3-31 All launch vehicle data pertaining to this circuit has been reviewed and no anomalies have been found. An intermittent condition could exist somewhere within this system to cause this anomaly. Based on the time of this happening, it has been concluded that this is unrelated to the accident.

ITEM CLOSED

ITEM CLOSED

ITEM CLOSED

ITEM CLOSED

STATUS OF INVESTIGATION ITEMS

ITEM NO.	ITEM	STATUS		ANALYSIS	
		Investigation/Validation Action In Work	Validation Completed	Did Not Cause Accident	May have Contributed to Accident
37	Water-glycol accumulator quantity starts decreasing 2331:13.0	2-13	2-13	3-14	
		Attributed to increasing cabin pressure, since accumulator diaphragm is vented to cabin pressure. The water-glycol accumulator transducer sensed the increase in cabin pressure and interpreted this as a decrease in water-glycol quantity.			
38	Pilot suit flow starts to fluctuate 2331:14.3, but violently at 2331:16.2	2-13	2-13	2-27	
		Characteristic of suit flow indications with restrictions caused by pilot movements or physical activity.			
39	GSE DC power commanded off 2332:46.4	2-10	2-10	2-10	
		ACE data shows that the ground DC power was commanded off at 2332:46.4 and that the power was off at 2332:47.7. This is in accordance with the emergency procedures.			
40	Glycol pump discharge pressure starts increasing 2331:14.4	2-13	3-14	3-14	
		Attributed to boiling of water-glycol within the lines when subjected to intense heat.			

ITEM CLOSED

ITEM CLOSED

ITEM CLOSED

ITEM CLOSED

STATUS OF INVESTIGATION ITEMS

ITEM NO.	ITEM	STATUS		ANALYSIS	
		Investigation/Validation Action In Work	Validation Completed	Did Not Cause Accident	May have Contributed to Accident
41	Use of loose equipment in chromatograph compartment	3-3	3-10	3-14	
		The storage of loose items has been established prior to crew ingress and all were found still in the compartment after the test. However, some of the equipment may have been moved but there is no evidence to support this belief. No films were contained in any of the cameras.			
		ITEM CLOSED			
42	Elapsed time indicator burned on Spacecraft 014 at Downey (unit associated with caution warning system).	2-10	2-10	2-10	
		The elapsed time indicator was physically examined on Spacecraft 012 and found to be satisfactory with no evidence of burning. (Reference TPS 053).			
		ITEM CLOSED			
43	Internal-external power history during entire test ----- Baseline information only. No Analysis Summary required.	2-22	2-23	2-23	
		A supplement to the electrical power history has been completed and was presented to the Board on 2-24.			
		ITEM CLOSED			
44	Bottle of MEK found in White Room.	3-3	3-22	3-22	
		Chemical analysis of the bottle has been obtained and it was determined to be MEK. Also a history of cleaning, painting and bonding in Spacecraft 012 has been completed. Use of the bottle on the day of the last test cannot be determined. (Reference Board Action 0147 and TPS MA-003)			
		ITEM CLOSED			



STATUS OF INVESTIGATION ITEMS

ITEM NO.	ITEM	STATUS		ANALYSIS	
		Investigation/ Validation Action In Work	Validation Completed	Did Not Cause Accident	May have Contributed to Accident
45	Two broken pressure transducers on ECU	2-22	3-31	3-31	
	The two transducers have been identified (suit supply inlet pressure and water glycol pump outlet pressure). Radiographic examination indicated no evidence of damage within these units. Also there were no visual fire paths from within the transducers.				
	ITEM CLOSED				
46	Couch resistance measurements and status of bonding straps	2-10	2-10	2-14	
	Two bonding straps from the floor to the S/C wall were installed but the two from the Z struts to the center couch were not installed due to parts shortage. Resistance checks were made on the crew couches which indicated an 1 ohm resistance. While this is high (normal 0.03 ohms) it is low enough to prevent any static charge buildup.				
	ITEM CLOSED				
47	Screwdriver caused arc in wire harness (Ref. DR 0917 dtd 1/23/67)	3-4	3-16	3-16	
	Inspection of the arced wire (No. 1C50A16 RCS Quad B + Roll Normal Control) has been completed and nothing suspicious was noted. However, an arc spot was noticed on the cover plate which is located in a different area. Reinspection of the area in which the screwdriver drew an arc has shown that it did not contribute to the fire. (Ref: Item No. 34)				
	ITEM CLOSED				
48	ACE control and computer room configuration	2-18	2-10	2-10	
	The ACE Control Room No. 1 and Computer No. 1 configuration have been defined. All indications are that the system operated properly, that no spurious commands were transmitted and in no way contributed to the accident.				
	ITEM CLOSED				

STATUS OF INVESTIGATION ITEMS

ITEM NO.	ITEM	STATUS		ANALYSIS	
		Investigation/Validation Action In Work	Validation Completed	Did Not Cause Accident	May Have Contributed to Accident
49	Review of past floodlight failures and floodlight examination and testing.	3-3	3-10	3-14	
		The exact configuration of floodlights during the last test has been reviewed. All six floodlights have been removed and have been examined and tested, and were found to be satisfactory. (Reference TPS 028, 029, 032, 033 and 059).			
50	$H_2$ tank fan motor variation 2:26:30.4	2-10	3-10	3-10	
		GSE access connector J 22 which normally carries this measurement has been verified as not connected during the accident. Re-analysis of this data variation has been completed. The variation is attributed to random noise in the ACF station.			
51	Hole in translation controller	2-10	2-15	2-15	
		The Fire Analysis Panel has completed their investigation of the translation hand controller. There is no evidence that an explosion occurred inside the controller. It was probably hit by a foreign object. (Reference TPS 022).			
52	Waste management system blower motor failure on Spacecraft 008	2-13	2-15	2-15	
		The WMS blower selector switch has been determined to have been in the OFF position immediately prior to the incident (T-10 min.) per OCP. Post test switch list shows the selector switch in the OFF position. Examination of the blower motor showed no evidence of any electrical difficulty.			

ITEM CLOSED

ITEM CLOSED

ITEM CLOSED

ITEM CLOSED

STATUS OF INVESTIGATION ITEMS

ITEM NO.	ITEM	STATUS		ANALYSIS	
		Investigation/Validation Action In Work	Validation Completed	Did Not Cause Accident	May have Contributed to Accident
53	Review of heater failures and hardware examination.	3-1	4-1	4-1	
		History data has been received and has been evaluated. There are six different uses for heaters. The review of the failure history of the heaters concluded that no significant problem could be associated with the 204 accident.			
		ITEM CLOSED			
54	Review of ECS water-glycol leakage on O12	3-3	4-1	4-1	
		A detailed survey of all leakage has been completed. After the accident all connectors subject to past water-glycol spills. No evidence of internal arcing was found that could be attributable to prior water-glycol contamination.			
		ITEM CLOSED			
55	RCS thruster temperature sensor indicates cabin rupture, 2331:19.8	2-10	2-10	2-14	
		This time correlates with the time indicated by the C&N and cabin measurements for the pressure shell rupture. (Response time for this measurement system being obtained.)			
		ITEM CLOSED			
56	Lithium hydroxide canisters non-flight type	2-17	3-8	3-10	
		A detailed analysis of the data associated with the oxygen suit loop indicates normal temperatures until approximately 10 seconds after the fire call. It has been concluded that the canister damage was a result and not a cause of the accident.			
		ITEM CLOSED			

STATUS OF INVESTIGATION ITEMS

ITEM NO.	ITEM	STATUS		ANALYSIS
		Investigation/Validation Action In Work	Validation Completed	
57	Analysis of gas from 2 Beckman oxygen analyzers	2-13	2-15	2-15 Neither of the O <sub>2</sub> analyzers contained significant gaseous materials (more than 500 ppm) of anything other than air components. Trichloroethylene was found in the silica gel of the analyzer used for the last sample. This could result from any previous use. (Ref. TPS 007).
58	On board recording equipment and electrical connector configuration.	3-6	3-14	3-14 Post test physical verification indicates that the DSEA (LEM recorder) was not connected electrically; however, the cable was "hot" per the switch configuration. Electrical wiring has been inspected and no indications of arcing or other damage were noted. (Ref. Board Action No. 0153 and TPS CM-IV-041).
59	Structural assessment report ----- Baseline information only. No Analysis Summary required.	2-10	2-10	2-19 The results of Panel 10 preliminary visual inspection have been prepared and forwarded to the 204 Review Board.  ITEM CLOSED
60	History of all Apollo Program fires ----- Baseline information only. No Analysis Summary required.	2-13	4-1	4-1 Data received and has been reviewed for applicability. No correlation with past fires and the AS-204 accident were noticed.  ITEM CLOSED

STATUS OF INVESTIGATION ITEMS

ITEM NO.	ITEM	STATUS		ANALYSIS
		Investigation/Validation Action In Work	Validation Completed	
61	Spark ignition possibility	3-20	4-1	4-1 May have Contributed to Accident Electrostatic spark ignition testing determined that ignition by electrostatic discharge is not probable explanation of a ignition source. For details see panel 8 final report.
62	Water Glycol pump failure on Spacecraft 008	2-22	3-16	3-17 ITEM CLOSED Pump cap configuration on S/C 008 was plastic. It has been determined that the configuration S/C 012 utilized an inconnel cap. This has been validated during tear-down of the ECU. Inspection showed that the inconnel cap allowed no leakage into the pump motors and that the pumps were in satisfactory condition. ITEM CLOSED
63	Oxygen flow rate sharp increase to measurement limit 2224:03	2-13	2-23	2-23 ITEM CLOSED Tests and data have determined that O <sub>2</sub> flow rates are affected by crew activity. Crew activity has been correlated to the rise in O <sub>2</sub> flow.
64	Oxygen flow master alarm time excessive, 27 instead of 15 seconds 2145:54	2-13	2-23	2-23 ITEM CLOSED It can be inferred that this was not a malfunction because this period of high O <sub>2</sub> flow was interrupted by cyclic accumulator action, and because the time delay worked properly at all other times including during the accident.

STATUS OF INVESTIGATION ITEMS

ITEM NO.	ITEM	STATUS		ANALYSIS
		Investigation/Validation Action In Work	Validation Completed	
65	ECS water glycol system history during test ----- Baseline information only. No Analysis Summary required.	2-10	2-10	Did Not Cause Accident May have Contributed to Accident
				2-19
		Input provided to Board. Action completed.		
66	Oxygen system history during test ----- Baseline information only. No Analysis Summary required.	2-13	2-15	
		Input provided to Board. Action completed.		
		ITEM CLOSED		
67	Communication System history during test. ----- Baseline information only. No Analysis Summary required.	2-14	2-15	
		Input provided to Board. Action completed.		
		ITEM CLOSED		
68	Review of all elapsed time indicators used on S/C 012 of type to be removed before flight.	2-10	2-15	
		A check was made of all of these indicators on S/C 012 and found to be satisfactory with no evidence of short circuits or burning. (Ref. TPS S/C 012-054).		
		ITEM CLOSED		
		ITEM CLOSED		

STATUS OF INVESTIGATION ITEMS

ITEM NO.	ITEM	STATUS		ANALYSIS
		Investigation/Validation Action In Work	Validation Completed	
69	ECS Fire at AiResearch	2-19	3-7	Did Not Cause Accident May have Contributed to Accident
		<p>The fire which occurred on April 28, 1966 during the mission life qualification test of the ECS was attributed to ignition of electrical heater tape which was installed as part of the test equipment. No such commercial grade tape was used on Spacecraft 012.</p>		
70	VHF-AM Receiver failure encountered on Spacecraft 008	2-13	2-15	2-17
		<p>This was not a transceiver failure but was caused by a cut in a wire. This failure has no applicability to S/C 012.</p>		
71	Suit loop return valve leak encountered on Spacecraft 008	2-13	3-6	3-7
		<p>Failure data obtained from NAA and applicability of failure reviewed with respect to 204 accident. It has been determined that the leakage problem encountered on S/C 008 cannot be associated with the cause of S/C 012 accident.</p>		
72	MTVC (Manual Thrust Vector Control) engage came on during earlier tests of Spacecraft 012 (Ref. DR 0868 dated 12 28 66).	2-10	3-6	3-6
		<p>After an inspection of the SCS wiring schematics associated with the MTVC mode and a review of all its associated data, it is concluded that the MTVC signal was a "False" signal. The malfunction was probably in the harness between the SCS and the PCM system.</p>		

ITEM CLOSED

ITEM CLOSED

ITEM CLOSED

ITEM CLOSED

STATUS OF INVESTIGATION ITEMS

ITEM NO.	ITEM	STATUS		ANALYSIS
		Investigation/Validation Action In Work	Validation Completed	
73	Identify all AC wires going to ECU ----- Baseline information only. No Analysis Summary required.	2-10	3-3	Did Not Cause Accident 3-3  All wires identified for two interface connectors.
74	AC Bus 2 phase C short during prior test on spacecraft 012 (Ref. DR 0903 dated 1/13/67)	2-10	3-19	3-19  ITEM CLOSED  This short occurred while obtaining a voltage measurement. A 1/8 amp fuse was blown in the instrumentation circuits. It was determined that the fuse protected the AC 2 instrumentation system and this short had no relation to the accident.
75	Relay terminal wires exposed on 15 second timer on Spacecraft 012 (Ref. DRS 692 dated 11/27/66)	2-23	2-24	2-24  ITEM CLOSED  Permanent Installation and Removal Record shows relay was potted and properly reinstalled. Post test evaluation shows potting on relay is intact and relay was properly installed. Test data shows relay performed its function properly.
76	Review of Panel 24 difficulties on 012	3-3	3-14	3-14  ITEM CLOSED  Thirteen DR actions were noted. The major problem was wire insulation damage because of the very tight envelope allotted to this panel. Tests have shown that electrical continuity was present after the fire and that no damage of any significance has been incurred by the switches, panel wiring or connectors.



STATUS OF INVESTIGATION ITEMS

ITEM NO.	ITEM	STATUS		ANALYSIS	
		Investigation/Validation Action In Work	Validation Completed	Did Not Cause Accident	May have Contributed to Accident
77	Three Saturn S-IVB measurement anomalies 2325:44	2-14	4-1	4-1	
		The reason for this data change has not been found, but at this time, 2325:44, it is considered to be unrelated to the incident.			
78	"Buttermilk Odor" in Suit Circuit G-5 1810	2-14	3-7	3-7	
		An evaluation of the reported odor has been completed. No impurities were noted from the K-bottle source; also no particular suspect item was identified as emitting a "sour milk" odor, although some RTV potting compounds have a pungent odor, that may fit this odor description.			
79	SCS Yaw ECA Female Connector J95 Blackeden Areas	3-3	3-14	3-14	
		Other ECA connectors and mating connector show no similar damage. Pins 4, 42, 80, 81, 82 have a blackened area. The area around pins 80, 81, and 82 has been shown to be a previous repair. The mating connector was perfectly clean. Pins 4 and 42 were spares. It was concluded that the connector had nothing to do with the fire.			
80	+Roll Output 2331:14.5 to 2331:15.0	2-13	2-23	2-23	
		Tests at MSC have shown that the rotational controller will produce an output when hit, even though the handle is pinned and locked. The handle was found pinned and locked, and the data therefore indicates a physical blow to the controller by one of the crew members.			

ITEM CLOSED

ITEM CLOSED

ITEM CLOSED

ITEM CLOSED

STATUS OF INVESTIGATION ITEMS

ITEM NO.	ITEM	STATUS		ANALYSIS	
		Investigation/Validation Action In Work	Validation Completed		Did Not Cause Accident
81	Gassing characteristics of Pyro batteries	3-6	3-7	3-9	Preliminary tests have been completed at MSC. Results indicate that is only a 2 psi pressure increase at normal room temp. during a 16 day period. Another battery was tested at 105 + 5 degrees F. and under worst conditions, H <sub>2</sub> venting would occur after approximately four days. Post test inspection of batteries showed them to be in satisfactory condition. (Ref. Board Action 0112). ITEM CLOSED
82	MTC was engaged at 2:37:18.5	2-14	2-23	2-23	For some unknown reason, the T-handle of the translation controller was turned to a full clockwise position. There can be much speculation as to how and why it was turned, but the answers are not considered significant. ITEM CLOSED
83	Start Senior Pilot activity (slight increase in heart rate and change in respiration) 2330:22	2-23	3-1	3-1	A moderate increase in heart and respiratory rates at this time. These data do not indicate the degree of activity that would be expected had the Senior Pilot been aware of an emergency situation. ITEM CLOSED
84	Senior Pilot heart rate increase, aware of danger 2331:04	2-23	3-1	3-1	A marked change in the Senior Pilot's respiratory and heart rate was seen at this time and continued until loss of signal. This physiological response is compatible with the realization of an emergency situation. ITEM CLOSED

STATUS OF INVESTIGATION ITEMS

ITEM NO.	ITEM	STATUS		ANALYSIS	
		Investigation/Validation Action In Work	Validation Completed	Did Not Cause Accident	May have Contributed to Accident
85	Shorting in MDAS octopus cable and connectors	2-25	4-1	4-1	
	Shorts were found on the octopus cable which provided power to the MDAS. The MDAS was still operating until LOS. The shorting was found to be superficial and a result of the fire.				
86	Astronaut shocked during Spacecraft 101 Crew Compartment Fit and Functional Check	2-24	2-27	3-7	
	ITEM CLOSED				
87	Accumulator quantity and glycol pump inlet pressure start increasing to upper limit 2331:15.4	2-13	3-14	3-14	
	ITEM CLOSED				
	Accumulator quantity change attributed to change in water-glycol pressure. Pressure change attributed to boiling of water-glycol within the lines when subjected to intense heat.				
88	CO2 absorber outlet temp. starts increasing 2331:16.0	2-13	2-14	2-14	
	ITEM CLOSED				
	Post test observations indicate that loss of pressure suit circuit integrity occurred in the Command Pilot's pressure suit and/or return hose. Such an opening would allow warm cabin air to be drawn into the suit compressor. The CO2 Absorber Outlet Temp. indicates that the CO2 Absorber acted as a heat sink until this time when it and the suit manifold temp. began to increase.				
	ITEM CLOSED				

STATUS OF INVESTIGATION ITEMS

ITEM NO.	ITEM	STATUS		ANALYSIS	
		Investigation/Validation Action In Work	Validation Completed	Did Not Cause Accident	May have Contributed to Accident
89	Q Ball circuit integrity	3-6	4-1	4-1	
		The Q-Ball was not electrically mated for the plug-out test (OCP-0021). However, the cable was "hot" up to the Q-Ball connector. Resistance checks revealed no anomalies in the Q-Ball cable.			
90	Suit flow indication at low limit for Command Pilot from 2331:18.5 through LOS. Senior Pilot from 2331:18.5 through LOS. and Pilot from 2331:19.6 through LOS.	2-22	4-1	4-1	
		When cabin pressure rises rapidly, the increase in pressure results in restricting or stopping the flow. In addition, loss of integrity of inlet side of the suit circuit causes a drop in suit flow indication.			
91	Accumulator quantity reached upper limit 2331:17.1	2-22	3-14	3-14	
		Indicates beginning of overpressurization in the water-glycol circuit due to thermal expansion of the fluid.			
92	Glycol evaporator liquid temperature increasing 2331:17.5	2-22	3-14	3-14	
		Heating in the area to the left of, or within, the ECU. Supported by water-glycol pump inlet and outlet pressure and accumulator quantity.			

ITEM CLOSED

ITEM CLOSED

ITEM CLOSED

ITEM CLOSED

STATUS OF INVESTIGATION ITEMS

ITEM NO.	ITEM	STATUS		ANALYSIS	
		Investigation/ Validation Action In Work	Validation Completed	Did Not Cause Accident	May have Contributed to Accident
93	Command Pilot's Live Mike from approximately 22:18 to some time during the incident	2-23	3-18	3-18	
		Data indicates that the live mike condition began at approximately 22:18 and continued through the time the fire was first reported. An investigation on the Command Pilot's audio circuit has been completed. Based on the findings, it has been concluded that the live mike condition cannot be considered a source of ignition.			
		ITEM CLOSED			
94	Initial investigation determined that cabin air fan no. 1 shorted.	2-22	4-1	4-1	
		Post test inspection of Cabin Fan No. 1 has indicated shorting in Phase A and C circuits. Continuity checks of the cabin fan were satisfactory. The shorts were determined to be in the power cable. Due to the lack of fire propagation material and physical inspection, it is concluded that these shorts were not the cause of the accident.			
		ITEM CLOSED			
95	Etching of Teflon wire insulation a. FCU harness b. Gas chromatograph connector	3-17	4-1	4-1	
		All teflon insulated wiring is required to be etched before potting. Pretest records were examined to determine whether they show that these cable connectors were etched as required. Etching of the gas chromatograph wires was accomplished. Etching of the FCU harnesses was not required as it was the latest configuration.			
		ITEM CLOSED			
96	Suit current limiter panel short to teleflex cable	2-22	3-13	3-14	
		Terminal board 61 to be examined for evidence of shorting and 82556 resistors and conformal coating for overheating. A more detailed examination disclosed that there was no actual contact between the teleflex cable and the terminal board, and that there was no evidence of shorting or overheating.			
		ITEM CLOSED			

STATUS OF INVESTIGATION ITEMS

ITEM NO.	ITEM	STATUS		ANALYSIS	
		Investigation/ Validation Action In Work	Validation Completed	Did Not Cause Accident	May have Contributed to Accident
97	Panel 150 not installed and lying loose	2-22	3-14	3-14	
		Panel 150 has been inspected for arcing as part of the Spacecraft disassembly plan. (Reference Board Action Item 0120). There was no evidence of arcing or material outflow from any components on the panel.			
98	Command Pilot cobra cable and PCA connectors suspect	2-22	4-1	4-1	
		Cobra cable connector and pressure garment assembly (PCA) connectors have been examined for arcing and condition of pins. No arcs were found. Tests were conducted simulating the disconnections of these connectors while "hot". No ignition occurred in a gaseous mixture of oxygen and methyl ethyl ketone (MEK). ITEM CLOSED			
99	BMAG Power Switch Position During Accident Indeterminate	2-22	3-8	3-14	
		BMAG switch was examined to determine position during test, when position was changed, possibility of false detent position, and effect of this switch being in test position and also being in false detent position. Switch determined to have been in proper position before crew report of fire. ITEM CLOSED			
100	Close-out found on battery terminals and other equipment	2-22	4-1	4-1	
		The flash and firepoint of this polyvinyl chloride tape was established as 4850F. Inspection of the areas in which the tape was used has determined that the tape did not start the fire but did support combustion. ITEM CLOSED			

STATUS OF INVESTIGATION ITEMS

ITEM NO.	ITEM	STATUS		ANALYSIS	
		Investigation/Validation Action In Work	Validation Completed	Did Not Cause Accident	May Have Contributed to Accident
101	ECU back pressure controller	2-22	3-21	3-21	
		Back pressure controller examination revealed that motor rotates satisfactorily, and that all electrical continuity was within spec limits.			
		ITEM CLOSED			
102	Senior Pilot inlet hose disconnected	2-24	4-1	4-1	
		The inlet hose of the Senior Pilot was found disconnected. Investigation by Panel 11 revealed a sooting pattern which could have been made if the Senior Pilot's inlet hose was disconnected. It is inferred that the Senior Pilot disconnected his hose in preparation for emergency egress.			
		ITEM CLOSED			
103	Service propulsion system chamber pressure data IX drop	2-22	3-18	3-18	
		The service propulsion system SPS chamber pressure is sampled 100 times a second. The circuitry has been reviewed to determine if this data would show any significant DC power changes. No significant change was noticed during the period of the AC glitch at 2330:54.85.			
		ITEM CLOSED			
104	Battery B Loading	2-22	3-2	3-9	
		Battery B Loading was indicated at 3.52 amps compared to 1.76-1.9 amps for batteries A and C and 2 amps. A detailed evaluation of the data showed the difference was due to a PCM zero shift and not real data.			
		ITEM CLOSED			

STATUS OF INVESTIGATION ITEMS

ITEM NO.	ITEM	STATUS		ANALYSIS	
		Investigation/Validation Action In Work	Validation Completed	Did Not Cause Accident	May have Contributed to Accident
105	Suit wiring short circuit	3-8	3-28	3-28	
		Short circuit damage has been uncovered in part of the communications cabling on the Command Pilot's suit. Detailed inspection of the shorted wires revealed that the shorting and damage was due to external heat and burning.			
106	DC wiring for the Environmental Control System instrumentation was found burned through	3-23	3-31		3-31
		ITEM CLOSED			
		The probable cause of the accident is in the wiring providing instrumentation power for some of the ECS instrumentation.			





NATIONAL AERONAUTICS AND SPACE ADMINISTRATION  
APOLLO 204 REVIEW BOARD

IN REPLY REFER TO

March 31, 1967

INTEGRATION ANALYSIS SUMMARY

System Affected: Communications Subsystem

Item #2  
TPS N/A

Observation: Between 23:30:30 to 23:30:58, 5 GMT noise sounds were received on S-band

Discussion and Analysis:

The noise sounds were analyzed by Bell Labs and MSC. The results are not conclusive as to what caused the sounds. The sounds were similar to those of tapping and brushing a microphone. During the time period the microphone was "live," noises of this nature occasionally were received; however, the frequency of the noises during the period of 23:30:39 to 23:30:58 GMT was much higher. A relaxed breathing cadence was superimposed on the sounds. The sounds were recorded on both the S-band and VHF voice tracks, although the crew was on S-band. This is as expected, due to the ground communication system which retransmits the S-band through a VOX controller circuit over a VHF transmitter. These transmissions are received by the VHF receiver on the ground and are recorded. The ground receiver does not differentiate between transmissions from the spacecraft VHF transmitter and the ground VHF transmitter. The proof that the noises were generated through the S-band is the fact that the noise sounds appear on the S-band track first and, with a short delay, then appear on the VHF track. The delay is the time required for the retransmissions through the VOX controller circuit. Further, some of the sounds were not of sufficient level to trigger the VOX and, therefore, were not recorded on the VHF voice track.

ENCLOSURE 18-53

D-18-166



NATIONAL AERONAUTICS AND SPACE ADMINISTRATION

APOLLO 204 REVIEW BOARD

IN REPLY REFER TO

March 21, 1967

INTEGRATION ANALYSIS SUMMARY

System Affected: Guidance and Navigation Subsystem Item #3  
TPS N/A

Observation: Gimbal angle data indicates movement just prior to fire call

Discussion and Analysis:

Analysis of telemetered data from past testing of S/C 012 has shown the following signals are indicators of torque or angular disturbances of the G&N Navigation Base with respect to an inertially stabilized IMU:

1. Gimbal Torque Motor Input
2. Gimbal Angle Resolvers
3. AGC Registers Recording Gimbal Angles.

The recordings of the ten (10) sample per second gimbal torquer input from S/C-012 OCP's 0034, 0034A, 0005 and 0021 were reviewed by personnel from NASA G&N - ACED-MIT in an attempt to correlate individual crew member movement within the S/C to disturbances noted on the gimbal torquer inputs.

The analysis indicated that definite individual crew movement could not be determined.

The gimbal torquer input indicated S/C disturbance but cannot distinguish between left, right or center crewman caused motion, and/or disturbances caused by forces external to the spacecraft.

The AGC CDU registers are telemetered once every two seconds and can only be used to indicate the angular relationship which existed at the sample time. Changes which take place faster than the sampling rate will not be indicated.

ENCLOSURE 18-53

D-18-167

Item #3 (Cont'd)

Based on the above, it has been concluded that only gross indication of Command Module motion can be determined and correlated.



NATIONAL AERONAUTICS AND SPACE ADMINISTRATION  
APOLLO 704 REVIEW BOARD

IN REPLY REFER TO

March 11, 1967

INTEGRATION ANALYSIS SUMMARY

System Affected: Electrical Power Subsystem

Item #4-  
TPS N/A

Observation: Increase on Ground Power Supply B at  
2321:20.5 GMT

Discussion and  
Analysis:

The four bit increase (1/2 amps) was observed on the ACE Control Room real time recorder and also on a playback from track 5. The interim output is recorded also on track 3. Track 3 did not show the 1/2 bit increase. Analysis of the interleaver wave train output at this period of time indicate that the magnitude of the wave train (track 3) output did decrease slightly at this time although the bit stream was readable and the 1/2 bit increase on power supply B was there.

During this period of time, there was VHF/AM transmitter keying which draws 1.1 amps with no modulation and an additional 0.5 amp with modulation. The VHF/AM transmitter is powered from the Post Landing Bus which is powered from both Main A and B buses in the CM thru isolating diodes. There was no other activity going on in the S/C at this time that could be detected from the data. Although the data is questionable, there are several factors that could have caused this indication.

- (1) The power supplies A & B could have momentarily shifted their shared load (Post Landing Bus Load) due to the power supply regulation characteristics. This could have occurred

Item #1. (Cont'd)

without being detected in the data since PSA current is sampled 100 milliseconds prior to Power-Supply B current. This phenomenon had been seen for longer periods of time where one power supply current would show a few bits increase and the other decrease.

(:) Another load could have been placed on at this time but since the data shows no other parameter activity during this period, there is no way this can be verified.

With the analysis that has been made and considering the time (2326:29.5 GMT) of this happening, it is concluded that this event could not have contributed to the cause of the fire.



NATIONAL AERONAUTICS AND SPACE ADMINISTRATION  
APOLLO 204 REVIEW BOARD

IN REPLY REFER TO

March 21 1977

INTEGRATION ANALYSIS SUMMARY

System Affected: Environmental Control Subsystem      Item #5  
TPS N/A

Observation: Gas Chromatograph output started to change  
from 2330:50 GMT until loss of data.

Discussion and Analysis: It has been determined that the gas chromatograph (GC) cable acted as an electromagnetic radiation detector (Ref. Item No. 22).

The gas chromatograph (GC) was not installed in Spacecraft 012 at the time of the accident. The GC connector was placed on the shelf of the gas chromatograph compartment. The connector was not bagged, and AC bus 1 phase A power was applied to the connector through a closed circuit breaker. Twenty-two gauge wire was used, protected by 2 amp circuit breaker. The circuit breaker for the GC was found to be open following the accident, with a heavily sooted condition which is indicative of opening during the early portion of the fire. The harness was not tied down in a flight configuration because the GC was not installed.

Two physical peculiarities were noted concerning the GC wiring and the connector. After the accident the harness and connector were found on the floor with the GC connector laying on a big harness. Two spot ties of this harness were found unblackened as a result of being protected by the GC connector.

ENCLOSURE 18-53

D-18-171

Item #5. (Cont'd)

The side of the connector that lay against the big harness and protected the two spot ties is badly burned and the potting at the back of the connector is melted. The GC connector was stuck to the big harness and had to be pried loose with a tool. It can be inferred that the connector was burning in a different location but fell or otherwise moved to its final location prior to the time the fire swept across that portion of the floor. It can also be inferred that the connector protruded beyond the GC compartment shelf and was burned in that location before it fell to the floor.

Secondly, the two GC AC wires exhibited peculiar melting characteristics. The output signal leads from the connector were fed through a fiberglass sleeve. One hundred-fifteen volt AC power was carried to the connector through a twisted pair of teflon-insulated conductors. These power conducting wires were run along the signal leads and were occasionally tied together. The power wires show a number of copper balls attached to their surfaces. This is the only instance that wires in this condition have been found in Spacecraft 012. The shorted DC wires to the J185 connector do show a couple of droplets; these are still being examined.

All attempts to simulate this condition by either short circuits or by application of external heat have not resulted in a similar appearance of the AC wires. It is inferred that these wires were subjected to both a short and to external heating from the fire. It is also inferred that this condition resulted as the harness fell through the flame to the floor.

X-ray and continuity tests of the connector pins and input wiring showed no evidence of arcs or short circuits. For this reason, this is not a suspect fire initiator.



NATIONAL AERONAUTICS AND SPACE ADMINISTRATION

APOLLO 204 REVIEW BOARD

IN REPLY REFER TO

February 10, 1967

INTEGRATION ANALYSIS SUMMARY

System Affected: Communications Subsystem Item # 0  
TPS N/A

Observation: VHF-FM video drops out for 30  
milliseconds at 2330:54.85 GMT

Discussion and  
Analysis: Tests completed at Collins Radio Company on  
a similar VHF-FM transmitter (reference  
Collins Radio Company report dated 2-7-67)  
show that the received video signal during  
the noted time can be matched very closely  
by a momentary dropout of the AC supply  
(all three phases) to less than 50 volts  
or a dropout of DC supply to less than 0.5  
volts for a period of 15 to 20 milliseconds.  
Comparison with Investigation Items 7 and 8  
leads to the conclusion that this was an  
effect of an AC bus 2 power interruption.

ENCLOSURE 18-53

D-18-173





Item #7 (Cont'd)

It is concluded that the probable cause of the AC bus transient and associated indications was a momentary short (1 to 5 milliseconds) of DC bus B affecting the input voltage to inverter 2.



NATIONAL AERONAUTICS AND SPACE ADMINISTRATION  
APOLLO 204 REVIEW BOARD

IN REPLY REFER TO

February 13, 1967

INTEGRATION ANALYSIS SUMMARY

System Affected: Communications Subsystem Item #8  
TPS N/A

Observation: C-band transponder drops to zero volts  
for approximately two seconds from  
2330:54.85 to 2330:56.0 GMT

Discussion and  
Analysis:

Tests by Collins Radio Company (reference  
TWX dated 1-30-67) indicate that the trans-  
ponder output characteristics can be matched  
by a drop in 3 phase AC voltage or phases A  
and B, or B and C. One phase loss would not  
cause the effect.

Dropout for very short intervals causes the  
C-band transponder to go to a protective  
mode to prevent magnetron damage. Normal  
recovery time for the C-band transponder is  
approximately 1.7 seconds.

Comparison with Investigation Items 6 and 7  
leads to the conclusion that this was an effect  
of an AC bus 2 power interruption.



NATIONAL AERONAUTICS AND SPACE ADMINISTRATION  
APOLLO 204 REVIEW BOARD

IN REPLY REFER TO

March 19, 1970

INTEGRATION ANALYSIS SUMMARY

System Affected: Environmental Control Subsystem

Item #:  
TPS N/A

Observation: Oxygen Flow Rate increased to off-scale high at 133:30.4 GMT

Discussion and Analysis:

Telemetered data indicate that the high oxygen flow rate conditions for the last 30 seconds (133:30.4) before the fire call can be attributed to the apparent high level of prime crew suit leakage at low suit-to-cabin differential pressure, magnified by apparent crew activity.

There has been considerable speculation as to whether the high flow could be indicative of a sensor and/or associated wiring difficulty.

The oxygen flow sensor circuit includes two separate outputs. The signal circuit going to the Pulse Code Modulation Telemetry System (PCM) is conducted to the PCM system through a twisted shielded pair of wires. A short circuit between the signal lead and either the return wire or the shield braid would cause a zero output (no flow) reading on the oxygen flow indication. It is highly improbable that any short circuit between the signal lead could occur without a prior short circuiting to the ground lead or shield lead.

ENCLOSURE 18-53

Item #7 (Cont'd)

The second output from the oxygen flow sensor circuit goes to a time delay relay to indicate high flow alarm. It is on the ground circuit return side of the relay. A ground circuit completion is required to indicate high oxygen flow. This is supplied from a separate circuit from that going to PCM, and a ground on this line could not affect the PCM flow rate indication.

Single failures could exist within the bridge circuitry controlling the flow sensor which would indicate high flow rates on both the PCM output and the signal to the relay. These, however, will require examination of the oxygen flow sensor box to confirm or deny this possibility. A preliminary examination disclosed shorts to ground in the flow sensor; shorts to ground will produce a zero or no flow output indication. The flow sensor box is being torn down at the present time. It should also be noted that the location of the oxygen flow sensor was a high fire damage area, and that the sensor would be expected to be damaged by the fire.

Based on the above, it is concluded that the high oxygen flow data indication was valid, and that there was no malfunction of the sensor and/or associated wiring prior to the fire call.



IN REPLY REFER TO

NATIONAL AERONAUTICS AND SPACE ADMINISTRATION  
APOLLO 204 REVIEW BOARD

April 1, 1967

INTEGRATION ANALYSIS SUMMARY

System Affected: Environmental Control System Item #12  
TPS N/A

Observation: Data indicate initial cabin temperature increase at 2331:06.4 GMT

Discussion and Analysis: The initial cabin temperature increase (measurement CF0002T) was observed at 2331:06.4 GMT.

This measurement is sampled one time per second on PCM.

Preliminary data determined that the cabin temperature transducer response time is approximately 5 seconds to 63.3 percent of full scale for a step increase; however, initial response time was unknown.

Tests conducted at AiResearch determined that the cabin temperature sensor would show an initial response of .25°F within 200 to 300 milliseconds when subjected to air at 130°F. In addition, the sensor output increased to 63.3 percent of full scale (125°F) in four seconds when subjected to an air temperature of 130°F.

It is, therefore, determined that the time of cabin temperature increase start is accurate to within  $\pm 1$  second.



NATIONAL AERONAUTICS AND SPACE ADMINISTRATION  
APOLLO 204 REVIEW BOARD

IN REPLY REFER TO

February 14, 1967

INTEGRATION ANALYSIS SUMMARY

System Affected: Environmental Control Subsystem      Item #13  
TPS N/A

Observation: Cabin pressure increase began at 2331:06.818  
GMT (battery pressure transducer)

Discussion and  
Analysis:

This measurement, CC0188P, was not installed in its final configuration since the flight batteries were not installed. The transducer lay on the floor of the cabin and, therefore, sensed cabin pressure instead of battery compartment manifold pressure.

The transducer has a 0 to 20 psia range and a response time of 1 millisecond. No additional filtering occurs on its PCM input circuit.

The measurement is sampled ten times a second on PCM.

It is, therefore, determined that the time of cabin pressure increase start is accurate to within  $\pm 100$  milliseconds.



NATIONAL AERONAUTICS AND SPACE ADMINISTRATION

APOLLO 204 REVIEW BOARD

February 14, 1967

IN REPLY REFER TO

INTEGRATION ANALYSIS SUMMARY

System Affected: Environmental Control Subsystem      Item #14  
TPS N/A

Observation: Cabin pressure increase began at 2331:08.417  
GMT (measurement CF0001P)

Discussion and  
Analysis: The transducer has a 0 to 17 psia range and  
a response time of 100 milliseconds. The  
measurement is sampled once a second on PCM.  
  
Because of the low sampling rate and limited  
range of this measurement, the most accurate  
time and value of cabin pressure increase  
should be from measurement CC0188P (Item #13).





NATIONAL AERONAUTICS AND SPACE ADMINISTRATION  
APOLLO 204 REVIEW BOARD

IN REPLY REFER TO

February 19, 1967

INTEGRATION ANALYSIS SUMMARY

System Affected: Guidance & Navigation Subsystem      Item #15  
TPS N/A

Observation: The inertial guidance gimbals angles measurements showed a change starting at approximately 2331:10 GMT to a maximum value between 2331:18 and 2331:19 GMT.

Discussion and Analysis: It has been determined that the change in gimbals angles data is attributed to the increase in command module pressure. Following 2331:19 GMT, the gimbals angles data started to return to their original levels. This change in the data traces is determined to be the relief of the pressure or rupture of the pressure vessel. This determination has been substantiated by data obtained during the vacuum chamber test.



NATIONAL AERONAUTICS AND SPACE ADMINISTRATION  
APOLLO 204 REVIEW BOARD

IN REPLY REFER TO

February 10, 1967

INTEGRATION ANALYSIS SUMMARY

System Affected: Electrical Power Subsystem Item #10  
TPS N/A

Observation: Entry battery B power transferred to main bus B and simultaneously entry battery C power transferred to main bus A at 2331:12.4 GMT

Discussion and Analysis: Two ground measurements and six PCM measurements show that the above occurred. These data are further substantiated by the position of switch S10 on panel 22. The switch position is indicative of pilot action to place the batteries on the buses. This action took place approximately eight seconds after the fire call.

It is conjectured that pilot action may have resulted from smoke obscuring the floodlights, giving the impression of loss of ground power, or the desire to keep power on the suit compressors in the event of loss of ground power because of the fire.



NATIONAL AERONAUTICS AND SPACE ADMINISTRATION  
APOLLO 204 REVIEW BOARD

IN REPLY REFER TO

February 10, 1967

INTEGRATION ANALYSIS SUMMARY

System Affected: Electrical Power Subsystem

Item #17  
TPS N/A

Observation: Entry battery A power transferred to main bus A and simultaneously entry battery C power transferred to main bus B at 2331:13.6 GMT

Discussion and Analysis:

Four PCM measurements show that the above occurred. These data are further substantiated by the position of switch S9 on panel 22. The switch position is indicative of pilot action to place the batteries on the buses. This action took place approximately nine seconds after the fire call.

It is conjectured that pilot action may have resulted from smoke obscuring the floodlights, giving the impression of loss of ground power or the desire to keep power on the suit compressors in the event of loss of ground power because of the fire.

ENCLOSURE 18-53

D-18-184



NATIONAL AERONAUTICS AND SPACE ADMINISTRATION  
APOLLO 204 REVIEW BOARD

IN REPLY REFER TO

February 10, 1967

INTEGRATION ANALYSIS SUMMARY

System Affected: Environmental Control Subsystem      Item #18  
TPS N/A

Observation: The master caution warning light came  
on at 2331:14.7 GMT

Discussion and  
Analysis:

This light was the result of a high oxygen ( $O_2$ ) flow indication. The oxygen flow rate measurement increased to the upper band limit of 1.06 lbs./hr. or five volts at 2330:59.4 GMT. Whenever the  $O_2$  flow rate instrumentation voltage reaches 5.3 volts or greater and stays at this voltage level continuously for 15 seconds, the master alarm will come on. A time delay was added to inhibit the alarm because of periodic action of the cyclic accumulator every 10 minutes for a 10-second interval.

ENCLOSURE 18-53

D-18-185





NATIONAL AERONAUTICS AND SPACE ADMINISTRATION  
APOLLO 204 REVIEW BOARD

IN REPLY REFER TO

April 1, 1967

INTEGRATION ANALYSIS SUMMARY

System Affected: Communications Subsystem

Item #20  
TPS N/A

Observation: A momentary interruption was observed in  
VHF-FM and S-Band data between 2331:17.398  
and 2331:17.659 GMT

Discussion and  
Analysis: The momentary interruption in VHF-FM and S-Band  
between 2331:17.398 and 2331:17.659 GMT is  
attributed to a soft short circuit occurring in  
the communication wiring.

ENCLOSURE 18-53

D-18-187



NATIONAL AERONAUTICS AND SPACE ADMINISTRATION  
APOLLO 204 REVIEW BOARD

IN REPLY REFER TO

March 16, 1967

INTEGRATION ANALYSIS SUMMARY

System Affected: Crew Biomedical Equipment

Item #21  
TPS(s) S/C-011  
S/C-056  
S/C-076  
S/C-085

Observation: Inspection report of Biomed Recorder

Discussion and Analysis:

The Medical Data Acquisition System (MDAS) was removed from the spacecraft and physically inspected. MDAS was found to be in exceptionally good condition with only minor smoke damage.

The data tape was reduced and valid data obtained except for several noise glitches which appeared on the biomed data channels. These glitches occurred randomly. The first one at 1828:02 GMT and the last one at 2324:00 GMT. These glitches or noise spikes are believed to be caused by RFI which has been duplicated by post test bench checks.

From the MDAS data playbacks, time code amplitude variations were noticed. Representatives from the MDAS tape recorder and tape vendors stated that these variations may be caused by handling (fingerprints, etc.) and by dust.

The MDAS time trace was also inspected for indications of a DC dropout. No dropouts were found. From the time the MDAS was turned on and the timer reset (1736:02 GMT) until LOS of the timer (2331:21.2 GMT), the timer operated normally with no loss or change in timing. Special tests were conducted to determine the effect on the timer from a main DC bus voltage transient. Voltage

Item #21 (cont'd)

2

transients from 24 volts to 8 volts and 5 volts for 1.5 ms to 8.8 ms showed no effects on the timing. The only transient that effected the timing was a voltage drop from 28 volts to zero for a duration of 10 ms to 25 ms.

Based on the PCM and the MDAS data, there are no indications that the MDAS contributed to the cause of the fire.





NATIONAL AERONAUTICS AND SPACE ADMINISTRATION  
APOLLO 204 REVIEW BOARD

IN REPLY REFER TO

March 10, 1967

INTEGRATION ANALYSIS SUMMARY

System Affected: Gas Chromatograph Item #22  
TPS N/A

Observation: Seven gas chromatograph variations observed  
in the time period 2204:45 to 2255:43 GMT.

Discussion and  
Analysis:

The gas chromatograph (CG) was not installed for this test (OCP-K-0021). The connector which carries the telemetry data signals and the required AC power was open ended and was placed on the GC shelf prior to the test. Power to the AC line in the connector was turned on during the test per the test plan.

Examination of records show variations on the GC trace seven (7) times prior to 2330:50 GMT. Further investigation of SC-012 data measurements showed that the GC trace variations correlated with power changes in various SC systems.

It was determined that the telemetry data line in the connector has the characteristics of an antenna, and consequently can detect changes in electromagnetic radiation within the spacecraft.

This phenomenon was verified by tests conducted in SC-008 CM at MSC.

The time of the aforementioned trace variations and correlation to system power changes are listed below:

1. 2204:45 GMT. GC trace changed in exact correlation with a rise in the VHF/FM RF output (CT0330V) when the transmitter was turned on. The GC output change was 2 to 3%.

2. 2206:54 GMT. This trace variation correlates with middle gimbal angle stabilization loop, GC 2147, responding to a fine align mode.

3. 2219:23 GMT. This change in the GC trace correlates to G&N going to coarse align.

4. 2220:90 GMT. This change in GC trace correlates with G&N going to fine align.

5. 2234:46 GMT. The Pilot turned update link to UHF.

6. 2253:13 GMT. ECS reported high O<sub>2</sub> flow and asked the crew if their face plates were open. The crew reported 'No'.

During their transmissions much SC background noise was encountered.

7. 2255:40 GMT. Spacecraft commander (CMD) had just changed cobra cables and was in the process of communications check at this time.

Conclusions drawn from the above data is that GC telemetry data line acted as an electromagnetic radiation detector.



NATIONAL AERONAUTICS AND SPACE ADMINISTRATION  
APOLLO 204 REVIEW BOARD

IN REPLY REFER TO

March 14, 1967

INTEGRATION ANALYSIS SUMMARY

System Affected: Communication Subsystem

Item #23  
TPS N/A

Observation: Final loss of all spacecraft data observed  
2331:21.0 to 2331:22.42 GMT

Discussion and  
Analysis:

The final loss of all spacecraft data is attributed to a loss of power or loss of a coax cable due to the burning and shorting of wire harnesses during fire.



NATIONAL AERONAUTICS AND SPACE ADMINISTRATION  
APOLLO 204 REVIEW BOARD

IN REPLY REFER TO

February 23, 1967

INTEGRATION ANALYSIS SUMMARY

System Affected: Stabilization & Control Subsystem      Item #24  
TPS N/A

Observation:      MTVC Pitch Rate Command observed at  
2330:54.847 GMT

Discussion and Analysis:      This command was seen on CH0074 (MTVC pitch rate) and CH1074 (MTVC yaw rate) as a one (1) bit change-of-state. The SCS frequently sees one (1) bit changes on measurements which are attributed to noise.

All data indicated that the SCS operated normally at the above time and did not contribute to the accident.



compressor delta pressure should increase and, in fact, did increase. The decrease in these parameters within about 2 seconds after the increase can only be interpreted as suit burn-through and/or subsequent reconnection of the outlet hose. Disconnection and reconnection of the outlet hose within a 2 second time period is highly unlikely. If this argument is to hold, the suit must have burned through to re-establish flow and sometime later the outlet hose was reconnected to the suit. The outlet hose was found connected after the accident, which tends to weaken the argument in light of possibility (c) which follows.

- (c) The suit inlet hose was found disconnected from the Senior Pilot's suit. An explanation of this could be that the Senior Pilot disconnected his suit inlet for emergency egress at the dropout of the suit flow.

Testing at MSC has confirmed that disconnecting a suit inlet hose will produce a dropout in suit flow similar to that which occurred at 2331:09.618 GMT. In addition the Senior Pilot's inlet hose was found disconnected and sooting was found on the inlet hose connector which infers it was disconnected during the fire.

Based on the above it is concluded that the Senior Pilot's hose was disconnected at 2331:09.618 GMT and caused the dropout in suit flow.



NATIONAL AERONAUTICS AND SPACE ADMINISTRATION  
APOLLO 204 REVIEW BOARD

IN REPLY REFER TO

March 20, 1967

INTEGRATION ANALYSIS SUMMARY

System Affected: Environmental Control Subsystem

Item #26  
TPS N/A

Observation: Oxygen surge tank pressure started to decrease at 2331:12.4 GMT

Discussion and Analysis:

High oxygen flow rates were encountered for 30 seconds prior to the report of fire. These flow rates are attributed to suit leak rates and crew activity which placed a demand on the suit pressure regulator to supply oxygen at a rate causing a decay in the surge tank pressure.

Test data have shown that flows in excess of 2.63#/hr. will result in a decay in the surge tank pressure.

It is concluded, therefore, that the oxygen surge tank pressure decay at 2331:12.4 GMT was the result of high oxygen flows into the suit loop and did not contribute to the initiation of the fire.







NATIONAL AERONAUTICS AND SPACE ADMINISTRATION  
APOLLO 204 REVIEW BOARD

IN REPLY REFER TO:

February 23, 1967

INTEGRATION ANALYSIS SUMMARY

System Affected: Stabilization & Control Subsystem

Item #29  
TPS N/A

Observation: Indication of RCS action at 2329:40 GMT

Discussion and  
Analysis:

The data during this period has been reviewed in detail and indicated RCS action was found to be erroneous. The variation does not appear on the digital data from CIF VHF-FM which is best at this time.

ENCLOSURE 18-53

D-18-198



NATIONAL AERONAUTICS AND SPACE ADMINISTRATION  
APOLLO 204 REVIEW BOARD

IN REPLY REFER TO

April 1, 1967

INTEGRATION ANALYSIS SUMMARY

System Affected: Stabilization and Control System

Item #30  
TPS PIB-004  
CM-1V-077

Observation: Rotation Controller output data indicates a transient of 1.5% at 2330:54.85 GMT

Discussion and Analysis:

The Rotation Controller (R/C) was charred, and the pistol grip handle badly burned. The boot at the pistol grip input to the device was partially burned away. The cover of the lid was buckled outward between the attachment screws on each side, evidently due to thermal stresses. The lower left rear corner (nearest astronaut's right knee) of the cover was disfigured and cracked.

A dark residue, apparently foreign to the pistol grip, was observed sticking to the right side of the grip. This residue was removed and determined to be a mixture of nylon and a terephthalate ester by chemical analysis.

The locking pin visually appeared to be intact; however, about one-sixteenth of an inch of unsooted pin was observed at the pin's exit point from the device which indicated that the pin had been slightly pulled out subsequent to soot deposition.

On the bundle, the polyethylene zipper tubing and the silicone rubber shrink sleeving were burned through from the cable egress point for approximately one foot. The cable and zipper tubing were not as badly burned over the remaining length left attached to the unit.

The insulation of four wires approximately one inch from the egress point of the cable from the device was nicked or split for about one quarter of an inch, or had the insulation burned and/or blasted away. Magnified examination of the exposed wiring indicated no arcing or shorting. Functionally these four wires are associated with the R/C direct rotation switch outputs and were not armed with 28 VDC for at least twenty minutes prior to the accident. Also the locking pin was installed at least twenty minutes prior to the accident which would not allow these switches to be actuated.

The radiographs indicated no anomalies in the R/C internal metal parts. In particular, the locking pin was determined to be intact.

The R/C cover was removed and no evidence of foreign material inside the device was observed. The potting on the terminal board in the lower rear corner of the device was darkened and appeared melted on both sides. Charring and crystalization of spot ties, and sooting of internal wire bundles was observed in the lower rear and middle rear of the device. The internal heat pattern appeared to be most intense in the lower rear left side of the device and then progressed upward and to the rear right side through the wires and components. Examination of the cover, which was bulged out (by thermal expansion) when attached to the controller, indicated that a hot gas flow pattern came from above the controller into the case through the cover bulges. The inside of the cover showed very definite indications of a hot gas flow

Item #30 (Cont'd)

3

pattern where the hot gas came in from outside the controller, was deflected by heavy internal components, and then flowed through the wires and components to the other side of the mechanism.

The review of the data, the continuity check and the insulation check have shown no evidence that the rotation controller or the associated wiring were a cause or propagator of the fire.

Special tests have shown that the null output transients can be duplicated by a momentary interruption of AC Bus 2 Phase A input power. It is therefore concluded that the AC interruption caused the rotation control transient. Information concerning AC interruption is contained in Integration Analysis Summary Item #7.





NATIONAL AERONAUTICS AND SPACE ADMINISTRATION  
APOLLO 204 REVIEW BOARD

IN REPLY REFER TO

February 23, 1967

INTEGRATION ANALYSIS SUMMARY

System Affected: Stabilization & Control Subsystem      Item #32  
TPS    N/A

Observation:      SCS roll rate oscillations starting at  
2331:03.85 GMT.

Discussion and  
Analysis:      The SCS roll rate oscillations at 2331:03.85 GMT  
are an indication of crew movement in the space-  
craft. This item correlates with launch vehicle  
accelerometer data, IMU gimbal angle data, and  
nothing more can be gained from additional study  
to try to determine the degree of crew movement.



NATIONAL AERONAUTICS AND SPACE ADMINISTRATION  
APOLLO 204 REVIEW BOARD

IN REPLY REFER TO

April 1, 1967

INTEGRATION ANALYSIS SUMMARY

System Affected: Launch Vehicle

Item #33  
TPS N/A

Observation: Launch Vehicle (LV) pitch and yaw accelerometers (DPIAOV-01-02 and CPIBOV-01-04) showed slight oscillation starting at 2331:04 GMT and increasing with maximum oscillation at 2331:20 GMT.

Discussion and Analysis:

The LV pitch and yaw accelerometers output data were reviewed to determine relationship with crew movements during the conduct of OCP-K-0021 (i.e., changing of cobra cables). No correlation was seen except during the above period. It is, therefore, determined that these data only indicate movement of the spacecraft after the accident.

ENCLOSURE 18-53

D-18-204





Item #34 (Cont'd)

2

The glycol spillage had been corrected by washing.

No change was noted in high sample rate data (200 samples per second), which should have indicated such a short, until after the time of spacecraft rupture.

Burning noted in the area of the junction box does not appear as severe as would be expected had the fire started here.



NATIONAL AERONAUTICS AND SPACE ADMINISTRATION  
APOLLO 204 REVIEW BOARD

IN REPLY REFER TO

March 1, 1967

INTEGRATION ANALYSIS SUMMARY

System Affected: Environmental Control System

Item #35  
TPS N/A

Observation: Suit differential pressure begins to increase at 2331:04.4 GMT

Discussion and Analysis:

The cabin pressure began to increase at 2331:04.4 GMT.

The oxygen demand regulator senses cabin pressure. An increase in cabin pressure or a decrease in suit pressure will cause the diaphragm of the O<sub>2</sub> demand regulator to be opened allowing O<sub>2</sub> to flow into the suit loop.

The suit differential pressure ( $\Delta P$ ) also began to increase at 2331:06.4 GMT since it tends to follow the trend of cabin pressure. Crew movement at this time will also add to the increase in suit  $\Delta P$ .

It is determined that the general rise in suit differential pressure was caused by increased cabin pressure and crew movement.

The rapid rise in the slope of suit  $\Delta P$  curve at 2331:09.6 GMT is attributed to the dropout of the Senior Pilots (SPLT) suit flow.

The drop in the suit  $\Delta P$  at 2331:11.5 GMT is attributed to the resumption of flow in the SPLT's suit inlet hose. The rapid rise in the suit  $\Delta P$  starting at 2331:12.4 GMT was caused by the rapid increase in cabin pressure.

Item #3 (Cont'd)

Information concerning the drop of crew suit flow to lower limits at 2331:1.4: GMT is discussed in Integration Summary Analysis Item #3.

It is concluded that the initial crew suit differential pressure increase was caused by crew activities and the latter increase was caused by the rapid rise in cabin pressure.



NATIONAL AERONAUTICS AND SPACE ADMINISTRATION  
APOLLO 204 REVIEW BOARD

IN REPLY REFER TO

March 31, 1967

INTEGRATION ANALYSIS SUMMARY

System Affected: Sequential System Item #36  
TPS N/A

Observation: Emergency Detection System (EDS) "Engine 8 out" light went out and came back on 8 seconds later, during the EDS tests at 20:52:23 GMT

Discussion and Analysis:

During the time of the anomaly the launch vehicle "attitude reference fail" check was being performed. EDS bus 1 was turned off and the astronaut was to verify no change in the panel 5 status light. However, he stated that the "Engine 8 out" light went off. This light came back on 8 seconds later as reported by the astronaut and verified on the voice tape. Data review showed no switching in the cockpit from the time the EDS bus 1 went off for approximately 39 seconds. No further information is available since this is the "B" side of the light and is not instrumented. The "Engine 8 out" light wiring has been checked for continuity both in the spacecraft and the launch vehicle with no abnormalities detected. An intermittent condition of this nature could be located anywhere in the system, however, the event could not have caused the fire.

ENCLOSURE 18-53



Items 37, 40, 87, 91, 92 (cont'd)

2

Increase in cabin pressure and interpreted this as a decrease in W/G quantity in the same manner as if the cabin pressure had remained constant and the W/G pressure had decreased.

The accumulator quantity continued to show a decrease until the W/G pressure (recorded at the pump inlet) began to increase at a very accelerated rate (2331:15.4 GMT).

The W/G accumulator quantity transducer again sensed the change in pressure differential and interpreted this as an increase in W/G quantity.

The accelerated rise of W/G pressure is attributed to boiling of the liquid within the lines when subjected to the intense heat of the fire. This phenomenon has been duplicated by testing.

A pressure rise at a slow rate was initially detected at both the inlet and outlet sides of the W/G pumps at 2331:14.4 GMT.

The rate of pressure increase and final pressure measurement for the outlet side of the W/G pumps were less than those recorded at the inlet side. This is attributed to the pumps acting as a restrictor since they are only designed to supply a 29 to 30 psi pressure to the system.

The late sensing of a temperature increase at the glycol evaporator (2331:17.5 GMT) is attributed to system lag. The normal flow sequence of the W/G subsystem during this test is from the pumps through the SM glycol radiators, GSE cooling equipment, W/G reservoir and finally to the glycol evaporator.

In summary, none of the above findings are considered to have contributed to the original cause of the fire but were initiated as a result of the fire. Data indicate that the W/G subsystem continued operating as an integral unit until after CM and line rupture at which time the glycol then acted as a fuel for the fire.





NATIONAL AERONAUTICS AND SPACE ADMINISTRATION  
APOLLO 204 REVIEW BOARD

IN REPLY REFER TO

March 14, 1967

INTEGRATION ANALYSIS SUMMARY

System Affected: Crew Equipment Item #41  
TPS N/A

Observation: Loose equipment which was stowed in the gas chromatograph compartment

Discussion and Analysis:

TPS 583 (checkout TPS) on S/C 012 specified that the following loose items were to be stowed in the gas chromatograph compartment at crew ingress:

1. 2 each - 16 mm seq. cameras
2. 1 each - 16 mm power cable
3. 1 each - hygrometer control unit
4. 1 each - hygrometer sensor cable and sensor
5. 1 each - hygrometer power cable

These items were stowed in plastic bags. The bags were removed by the Spacecraft Technician and passed out of the spacecraft after Command Pilot ingress and prior to hatch close-out.

The six items listed above were still in the Gas Chromatograph Installation Area as of February 10, 1967. The aforementioned spacecraft technician believes that the items have been moved within the area, but there is no evidence to support this belief. The cables were still neatly coiled as they were before the test.

In addition to these six items, the gas chromatograph pyro cable connector and power/sensor cable



connector are believed to have been placed on the floor of the compartment. After the incident, the pyro cable connector was in place on the floor of the compartment; however, the power/sensor connector was found on the aft bulkhead.

The primary area of interest was to determine if the crew had utilized any of the above equipment thereby causing the gas chromatograph cable and connector to fall on the aft bulkhead, therefore providing an explanation for the final location of the chromatograph connector.

Follow-up investigation showed that cameras' lenses and film had not been stowed for this test. It is therefore concluded that no final determination can be made as to crew activity into this compartment.



NATIONAL AERONAUTICS AND SPACE ADMINISTRATION  
APOLLO 204 REVIEW BOARD

IN REPLY REFER TO

February 10, 1967

INTEGRATION ANALYSIS SUMMARY

System Affected: Caution and Warning Subsystem      Item #42  
TPS S/C 053

Observation: Elapsed time indicator failure on S/C 014  
and ETI inspection on S/C 012

Discussion and Analysis: The elapsed time indicator for the Caution and Warning System was overheated and charred as a result of a capacitor short during a test on S/C 014 during factory checkout at NAA/Downey.

This time indicator and associated noise suppression capacitor for the Caution and Warning System were physically examined on S/C 012 and found to be satisfactory with no evidence of burning.



NATIONAL AERONAUTICS AND SPACE ADMINISTRATION  
APOLLO 204 REVIEW BOARD

IN REPLY REFER TO

March 22, 1967

INTEGRATION ANALYSIS SUMMARY

System Affected:

None

Item #44  
TPS MA-003

Observation:

Bottle of MEK found in white room

Discussion and  
Analysis:

A chemical analysis of the Methyl-ethyl Ketone (MEK) bottle found in the white room was completed in accordance with Board Action 0147.

The analysis determined that the material in the squeeze bottle was a very high quality MEK. The vaporization rate through the neck of the squeeze bottle in a controlled environment similar to the white room was established as seven milligrams per hour.

Use of the MEK bottle on the day of the accident could not be determined.



NATIONAL AERONAUTICS AND SPACE ADMINISTRATION

APOLLO 204 REVIEW BOARD

IN REPLY REFER TO

March 31, 1967

INTEGRATION ANALYSIS SUMMARY

System Affected:

Environmental Control System

Item #45  
TPS CM-CA-135  
CM-CA-137

Observation:

Two broken pressure transducers were noted on the ECU during post fire inspection

Discussion and Analysis:

The two transducers were identified as the suit inlet pressure and water glycol pump outlet pressure transducers. Both transducer connectors and associated wiring were damaged and electrical continuity checks showed all circuits open. No visual evidence of a fire path from within the transducers was found following removal of the covers. In addition, radiographic examination indicated no evidence of damage within the units.

The cabin pressure and water glycol outlet pressure transducer data indicated normal operation both before and after the fire.

The cabin pressure exceeded maximum operating range (17 psia) of the cabin temperature sensor transducer at 23:31.13.4 GMT while the water glycol loop exceeded the transducer maximum operating range (60 psia) at 23:31.15.4 GMT.

It is concluded that the transducer damage did not contribute to but was the result of the accident.



NATIONAL AERONAUTICS AND SPACE ADMINISTRATION  
APOLLO 204 REVIEW BOARD

IN REPLY REFER TO

February 14, 1967

INTEGRATION ANALYSIS SUMMARY

System Affected: Crew Equipment

Item #41  
TPS N/A

Observation: Bonding Straps on Crew Couches missing

Discussion and  
Analysis:

There are four crew couches grounding straps in the spacecraft, two from the floor to the spacecraft wall and two from the Z-strut to the center couch. The two from the floor to the wall were installed, and the other two were missing. They had not been installed due to parts shortage.

Bonding checks on the crew couches made after the test indicate resistances in the order of 1 ohm. While this is high compared with normal bonding requirements of 0.03 ohms, it is low enough to prevent any static charge buildup. It is thus determined that lack of bonding straps did not increase the possibility of a static charge buildup on the couch relative to the command module structure.



NATIONAL AERONAUTICS AND SPACE ADMINISTRATION  
APOLLO 204 REVIEW BOARD

IN REPLY REFER TO

March 16, 1967

INTEGRATION ANALYSIS SUMMARY

System Affected: Electrical Power Subsystem

Item #47  
TPS S/C-082

Observation: Screwdriver caused an arc in wire harness  
(Ref. DR 0917 dated January 23, 1967)

Discussion and  
Analysis:

Investigation of this Item was performed in accordance with Board Action 0060.

Discrepancy Report (DR) 0917 dated 1-23-67 states, arc drawn on technicians screwdriver during removal of cover panel for C15-1A52 J-Box.

Panel C15-1A52 is a wire junction panel located in the LEB, just left of the #3 Inverter and below the gas chromatograph installation.

The technician was requested to remove the panel to allow for trouble shooting behind it. He removed the cover and the two holding screws on the left side of the panel and the bottom screw on the right side. To gain access to the top right screw, he removed bundle spot ties, separated the wires, and inserted the screwdriver between them. In the process of trying to remove the screw, the screwdriver drew an arc. An inspection was made of all the wires in the immediate bundle and one temporary wire repair was made with "mystic" tape. Since the screw head was so badly wallowed out, the screw was finally removed with a pair of vise grip pliers. Because of the offset of the plier jaws, it was not necessary to go between the wires for the screw removal. After the panel was unfastened, it was left ajar for access to accomplish the original purpose of the removal.

The next day a permanent fix of the damaged wire was made with heat shrinkable teflon tubing. The technician then redressed the wire bundle. He then re-installed the panel with the two screws on the left side of the panel plus the left bracket which holds the cover. The technicians on the next shift installed the two screws on the right side, plus the cover holding bracket, and the cover. Because new screws were used and the way the wires were dressed, it was possible to tighten the screws with the screwdriver at a slight angle without going between wires. No tests or reverification checks were made on the wires in the affected bundle.

To get a better understanding of the work which took place, a simulation was made on SC 014 with the same technicians who did the initial work on SC 012.

Inspection February 12, 1967 of SC 012 cover on C-15-1A52 J-Box revealed the following:

1. One wire adhered to the melted plastic on the bottom of the cover plate.
2. The unprotected bottom of the harness badly burned.
3. The portion of the harness behind the cover plate was in good condition.
4. The relay wires were scorched.
5. Nothing suspicious was noted at this time of the wire associated with screwdriver arcing incident.

Re-examination of the cover plate on March 3, 1967 revealed signs of possible arcing caused by another wire.

A final inspection on March 4, 1967 of the wires in the area involved with the screwdriver arcing incident found no evidence which can be attributed to initiation of the fire.

Item #47 (cont'd)

3

It is concluded that the area in which the wire was damaged by the screwdriver incident during the removal of the cover on C-15-1A52 did not contribute to the accident. However, the splitting of the wire bundles into two bundles and consequent re-routing of part of this bundle created the possibility for damaging adjacent wires in the wire bundle.





NATIONAL AERONAUTICS AND SPACE ADMINISTRATION

APOLLO 204 REVIEW BOARD

IN REPLY REFER TO

February 10, 1967

INTEGRATION ANALYSIS SUMMARY

System Affected: Ground Support Equipment

Item #48  
TPS N/A

Observation: Configuration of ACE Control Room #1 and  
ACE Computer Room #1

Discussion and  
Analysis: ACE configuration established.

The ACE Control Room #1 and Computer Room #1 configurations have been defined and studied. All of the data indicate that the system operated properly, that no spurious commands were transmitted, and in no way contributed to the accident.



NATIONAL AERONAUTICS AND SPACE ADMINISTRATION

APOLLO 204 REVIEW BOARD

IN REPLY REFER TO

March 14, 1967

INTEGRATION ANALYSIS SUMMARY

System Affected: CM Floodlights

Item #49  
TPS(s) CM-CA-054  
CM-CA-053

Observation: Review of past floodlight failures and floodlight examination and testing

Discussion and Analysis:

Board Action 0169 directed the removal and investigation of the SC CM floodlights.

Removal and inspection of the floodlights were conducted in accordance with TPS CM-CA-053. Testing and evaluation of test results were conducted in accordance with TPS CM-CA-054.

Six qualified CM Interior Light Circuits were installed in SC 012 CM. These included the Left Hand Overhead (LHOH), Right Hand Couch (RHC), Left Hand Couch (LHC), Right Hand Strut (RHS), Left Hand Strut (LHS) and Right Hand Overhead (RHOH).

All interior lighting floodlights gave physical indications of having sustained extensive fire damage.

Of the six circuits that were known to be operating prior to the fire, three survived and functioned normally within the specification current limits following removal from the SC. The secondary circuits were not energized during the fire. All six of these circuits survived and functioned normally within specification current limits.

The three non-functioning circuits were the LHOH, RHOH and RHS primary circuits. These circuits were open and did not draw an input voltage up to 28 VDC.

ENCLOSURE 18-53

D-18-223

Visual examination of the aforementioned 3 lights indicated that they had been exposed to higher external temperatures than the other lights.

Tests performed by the vendor indicate that the inverter circuit of the lights will cease commutation at temperatures between 230 and 250°F. Failure of the circuit to commutate results in approximately 10 amps current drain and opening of a fuse is approximately 500 microseconds at six amps. After fuse opening, the circuit is open and does not draw current.

Since the lights that contained the non-functioning circuit were the same ones which sustained the higher heat damage it is deduced that their circuits reached temperatures above 230°F and de-commutation caused their associated fuses to open.

In summary it is concluded that the floodlights were not an initiator or major propagator of the fire. In addition, the damage to their exterior surfaces and opening of the three primary circuits were caused by exposure to the CM fire.



NATIONAL AERONAUTICS AND SPACE ADMINISTRATION

APOLLO 204 REVIEW BOARD

IN REPLY REFER TO

March 10, 1967

INTEGRATION ANALYSIS SUMMARY

System Affected: Cryogenic Gas Storage Subsystem      Item #50  
TPS    N/A

Observation:      H<sub>2</sub> tank fan motor variation at 2326:30.4 GMT

Discussion and Analysis:      Variations similar to those noted at 2326:30.4 GMT appeared periodically prior to the accident.

Test Procedure for OCP-K-0021 requires that all GSE access connectors be disconnected during this test.

It was verified that GSE access connector J22 was not connected at the time of the accident. Connector J22 normally carries the H<sub>2</sub> Fan Motor measurement (SF0363V).

Verification was accomplished by physical checks at LC34, 2030 GMT, February 2 and by review of Quality Control LC34 checklist, FO-K-10011, for OCP-K-0021.

The H<sub>2</sub> tank fan motor variation noted at 2326:30.4 GMT is attributed to random noise. This incident did not contribute to the S/C 012 accident.

ENCLOSURE 18-53



NATIONAL AERONAUTICS AND SPACE ADMINISTRATION  
APOLLO 204 REVIEW BOARD

IN REPLY REFER TO

February 15, 1967

INTEGRATION ANALYSIS SUMMARY

System Affected: Stabilization Control Subsystem      Item #51  
TPS S/C-022

Observation: Hole in the translation hand controller

Discussion and  
Analysis:

The translation control was mounted on CM 012 at the L/H side of the L/H couch and was noted after the accident to have a relatively large part of the upper R/H rear corner missing.

The translation control was inspected for fire damage at the MAB laboratory with the following results:

a. In general, the damage due to fire and intensity of charring and sooting is most evident at the upper right rear corner. Charring and sooting diminishes from that corner in general toward the bottom front area and the bottom rear area where little evidence of soot or heat searing is visible.

In this initial inspection, it did not appear that heating came from within the device. It also appears that the missing cover corner has been caused by a blow from the outside after the cover had heated above an embrittling temperature (greater than 1000°F). (Ref. Summary Report of TPS PIB-002)

b. The translation control was functionally tested and verified to be functioning normally. This indicates that the fire damage did not degrade the functional performance of the device. (Ref. Summary Report of TPS PIB-005.)

Item #51 (cont'd)

2

It is determined that the hole in the translation controller did not result from an action which may have contributed to the accident.



NATIONAL AERONAUTICS AND SPACE ADMINISTRATION

APOLLO 204 REVIEW BOARD

IN REPLY REFER TO

February 15, 1967

INTEGRATION ANALYSIS SUMMARY

System Affected: Waste Management Subsystem Item #52  
TPS N/A

Observation: Waste Management Subsystem blower failure  
(S/C 008)

Discussion and  
Analysis:

The Waste Management Subsystem (WMS) blower motor failed on S/C 008 after approximately three hours of continuous operation. Normal operation of the blower is for short periods (approximately five minutes or less) to provide gas flow only for the vacuum cleaner. Previously, the blower was used to provide gas flow during collection of urine and feces. Due to a design change, the WMS blower is no longer utilized during these operations and the hard lines involved connecting the blower to the selector valve have been disconnected and plugged. However, the electrical control of the blower by the selector valve has not been changed. Therefore, when the selector valve is moved to either the urine or feces position, the blower is started and forced to operate against a dead headed system. S/C 012 Waste Management Subsystem configuration was the same as S/C 008.

The WMS blower selector switch per recorded configuration was off at pre-ingress of the crew. Review of the OCP-K-0021 shows that the WMS blower selector switch was off immediately prior to the accident. Also, post test switch check list shows the WMS selector switch in the off position. Therefore, it is determined that WMS blower did not cause the accident.







NATIONAL AERONAUTICS AND SPACE ADMINISTRATION

APOLLO 204 REVIEW BOARD

IN REPLY REFER TO

April 1, 1967

INTEGRATION ANALYSIS SUMMARY

System Affected: Environmental Control Subsystem      Item #54  
TPS    N/A

Observation:                      Leakage of Water/Glycol

Discussion and Analysis:

There has been a history of water/glycol leakage and spillage in spacecraft 012. Some of this occurred during tests at the factory and some occurred before and during the removal of the ECU at KSC. The characteristics of the inhibitor used in the coolant water/glycol fluid leaves a residue that is electrically conductive, hygroscopic and flammable. Leaks of water/glycol occurred in the lower equipment bay and Environmental Control Unit area during earlier tests on Spacecraft 012. These leaks were mopped up and connectors and accessible wire harnesses were washed with distilled water and alcohol, and dried with nitrogen.

After the accident, all connectors were carefully disconnected, photographed, and inspected for any signs of internal burning or arcing. No evidence of internal arcing or burning was found which indicated a fire source. However, if the leakage or spillage had not been adequately cleaned up, it would provide a flame propagation path.



NATIONAL AERONAUTICS AND SPACE ADMINISTRATION  
APOLLO 204 REVIEW BOARD

IN REPLY REFER TO

February 14, 1967

INTEGRATION ANALYSIS SUMMARY

System Affected: CM Reaction Control Subsystem Item #55  
TPS N/A

Observation: CM Reaction Control Subsystem (RCS) thruster  
temperature indicates pressure shell rupture

Discussion and  
Analysis: Measurement CR 4561T CCW engine wall "A" system CM  
RCS showed nominal outside air temperatures (67.7°F)  
until 2331:19.8 GMT.

This time matches well the time indicated by G&N  
measurements and pressure measurements for pressure  
shell rupture (approximately 2331:18 to 2331:19 GMT).  
It is determined that the high temperature indicated  
by the RCS engine is an effect of the release of flame  
in the area by the pressure shell rupture.



NATIONAL AERONAUTICS AND SPACE ADMINISTRATION  
APOLLO 204 REVIEW BOARD

IN REPLY REFER TO

March 20, 1967

INTEGRATION ANALYSIS SUMMARY

System Affected: Environmental Control Subsystem

Item #56  
TPS S/C-061  
CM-MA-005  
CM-MA-006

Observation: Lithium Hydroxide Canisters utilized were non-flight configuration

Discussion and Analysis:

The lithium hydroxide (LiOH) canisters utilized during the conduct of OCP-0021 were unqualified, non-flight configuration and did not contain the 50% bypass provisions incorporated in the improved flight canisters.

A detailed review of the data associated with the crew oxygen suit loop indicates normal temperatures and circuit integrity until approximately 10 seconds after the "fire" call. At 2331:16 GMT both the suit supply temperature and LiOH canister outlet temperature started increasing which indicates loss of pressure suit circuit integrity, thus allowing warm gasses to be drawn into the suit compressor and thru the LiOH canister.

From the above it has been concluded that integrity of the LiOH canister remained until after the start of the fire. Also damage to the canisters was a result and not the cause of the accident.

ENCLOSURE 18-53

D-18-232



NATIONAL AERONAUTICS AND SPACE ADMINISTRATION

APOLLO 204 REVIEW BOARD

IN REPLY REFER TO

February 15, 1967

INTEGRATION ANALYSIS SUMMARY

System Affected: Environmental Control Subsystem      Item #57  
TPS S/C-007

Observation: Analysis of gas from the two Beckman Analyzers

Discussion and Analysis:

Two (2) Beckman Oxygen Analyzers were located in the Pad 34 S/C White Room to extract cabin and suit gas samples. Serial No. 4 analyzer was utilized in extracting the first cabin gas sample after a twenty (20) minute purge. S/N 3 analyzer was utilized in extracting the suit gas sample and the second cabin gas sample after a ten (10) minute additional purge.

The MAB performed a lab analysis of gas samples taken from the analyzers to determine the presence of contaminants which would be indicative of cabin contamination (reference TPS S/C 012-007).

The determinations of the MAB lab analysis are as follows (reference Report MAB-101-67, dated February 6, 1967):

1. Neither of the analyzers contained significant gaseous materials (more than 500 ppm) of anything other than air components. The S/N 3 analyzer did contain trichlorethylene, most of which was absorbed in the gel cartridge.
2. The air in the analyzers can be accounted for by one and probably both of the following:
  - a. The bulbs were squeezed by someone before being impounded.

b. The time delay (approximately one week) between use and analysis resulted in air leakage into the system and/or sample loss.

Upon completion of the lab analysis, both analyzers were checked by measuring their response to ambient air, 100% aviators breathing oxygen and 100% nitrogen. The results are as follows:

1. Serial No. 3 analyzer

- a. Ambient air - 20% O<sub>2</sub> reading
- b. 100% O<sub>2</sub> - 100% O<sub>2</sub> reading
- c. 100% N<sub>2</sub> - 0% O<sub>2</sub> reading

2. Serial No. 4 analyzer

- a. Ambient air - 14% O<sub>2</sub> reading
- b. 100% O<sub>2</sub> - 100% O<sub>2</sub> reading
- c. 100% N<sub>2</sub> - Below O<sub>2</sub> reading

It is determined that the analysis of gas samples taken from the two (2) Beckman Oxygen Analyzers has given no indication of cabin contamination which may have contributed to the accident.



NATIONAL AERONAUTICS AND SPACE ADMINISTRATION

APOLLO 204 REVIEW BOARD

IN REPLY REFER TO

March 14, 1967

INTEGRATION ANALYSIS SUMMARY

System Affected:      Communication Subsystem      Item #58  
TPS    N/A

Observation:      On-board recording equipment and electrical  
connector configuration

Discussion and  
Analysis:

The following recording devices were on-board  
S/C 012 at the time of the incident:

- a. FQ Recorder, V16-75410Z, S/N Flt 12  
This recorder was loaded with tape, the cover was installed and the recorder was electrically connected. The recorder was not on at the time of the incident and would not have been turned on until into the mission run section of the test.
- b. DSE Recorder, V16-714385, S/N BAD0003  
This recorder was loaded with tape, the cover was installed and the recorder was electrically connected. The recorder was not on at the time and would have been turned on immediately prior to liftoff.
- c. MDAS, Part #511076, Serial #6721A  
This system was connected to the Senior Pilot, after crew ingress and was in operation from ingress through the incident.
- d. DSEA Recorder S/N 104  
Note that only one DSEA recorder was installed on the spacecraft. This recorder was installed in the #2 slot, the alternate slot, and existing paperwork indicates the recorder was connected. Physical verification on 4 February indicated that a DSEA recorder was located in the

Item #58 (cont'd)

2

alternate position, but that neither the power cable was connected to the recorder nor was the adapter cable connected to the recorder. The power cable at the DSEA end was not capped. Due to the activation of S13 and CB49 on Panel 22 AC power was present at the DSEA end of the cable and DC power was present due to the activation of CB 96 on Panel 22.

Inspection of the DSEA cable showed no evidence of arcing.

There is no indication that any of the on-board recording equipment was the cause of the fire.



NATIONAL AERONAUTICS AND SPACE ADMINISTRATION  
APOLLO 204 REVIEW BOARD

IN REPLY REFER TO

April 1, 1967

INTEGRATION ANALYSIS SUMMARY

System Affected: Crew Equipment Item #61  
TPS N/A

Observation: A survey should be made to evaluate the potential magnitude of electrostatic energies in the Command Module.

Discussion and Analysis: Exploratory tests with suit materials and other nonconducting materials used in the spacecraft indicated that large electrostatic energies could be generated, retained and discharged. As a result of the exploratory tests a detailed test program was generated to evaluate the potential magnitude of electrostatic charge buildup and the possibility of a discharge igniting materials or gases in the area of the discharge. Details of these tests can be found in the Panel #8 Final Report.

The electrostatic testing determined that ignition of solid materials by electrostatic discharge is not a probable explanation of an ignition source for the accident.

It is concluded that electrostatic energies from the Command Module non-conducting materials did not contribute to or cause the accident.





NATIONAL AERONAUTICS AND SPACE ADMINISTRATION  
APOLLO 204 REVIEW BOARD

IN REPLY REFER TO

March 17, 1967

INTEGRATION ANALYSIS SUMMARY

System Affected: Environmental Control Subsystem      Item #62  
TPS CM-CA-121

Observation: Investigate water glycol pump failure on  
S/C 008 and inspect S/C 012 pumps

Discussion and  
Analysis:

The plastic pump cap configuration on S/C 008  
water glycol pump allowed leakage which con-  
tributed to the pump motor failure.

The S/C 012 water glycol pumps utilized an  
Inconel cap between the magnet side and the  
magnetic motor side.

Investigation of the ECU water glycol pump was  
conducted in accordance with Board Action Item  
#0168.

Tear-down of the pumps revealed that the Inconel  
caps had allowed no leakage and that the motors  
were in satisfactory condition. It is noted that  
the water glycol pumps operated satisfactorily  
before, during and after the fire.

It is concluded the S/C 008 water glycol pump  
failure was not duplicated on S/C 012 and that  
the S/C 012 water glycol pumps did not con-  
tribute to the initiation of the fire.



NATIONAL AERONAUTICS AND SPACE ADMINISTRATION  
APOLLO 204 REVIEW BOARD

IN REPLY REFER TO

March 21, 1967

INTEGRATION ANALYSIS SUMMARY

System Affected: Environmental Control System      Item #53  
TPS    N/A

Observation: Sharp increase in oxygen flow rate, to measurement limit at 2324:03 to 2324:06 GMT.

Discussion and Analysis: Communications and bio-medical data indicates crew activity at this time.

It has been determined from previous tests and early in this test that oxygen flow rates are affected by crew movement and activity.

It is concluded that the sharp increase in oxygen flow rate was caused by crew activity.



NATIONAL AERONAUTICS AND SPACE ADMINISTRATION

APOLLO 204 REVIEW BOARD

IN REPLY REFER TO

February 23, 1967

INTEGRATION ANALYSIS SUMMARY

System Affected: Environmental Control Subsystem      Item #64  
TPS N/A

Observation: Excessive alarm time observed following high oxygen flow indication at 21:45:54 GMT

Discussion and Analysis: The oxygen ( $O_2$ ) flow transducer assembly, C23A2A5, has two outputs; an analog to the data system (PCM and cabin meter), and an event to the 15 second time delay associated with the input to the caution and warning system. The PCM system saturates (reads full scale) at a transducer output of 5.0 volts. Information from AIRsearch acceptance testing of this particular transducer assembly indicates the event output does not trigger until the analog output reaches 5.3 volts.

At 21:46:21.5 GMT the master caution was triggered by the 15 second time delay. This was 15 seconds after the  $H_2O$  cyclic accumulator assembly had cycled. It is assumed that the accumulator step  $O_2$  flow (the PCM input was saturated at 5 volts as previously noted at 21:45:54 GMT) and was sufficient (above 5.3 volts with a step requirement) to immediately close the "reed" relay (event output) in the  $O_2$  flow transducer assembly. The original high  $O_2$  flow was at a sufficient level or had increased to a sufficient level during the  $H_2O$  accumulator cycle to hold the "reed" relay in when the accumulator cycle was complete.

ENCLOSURE 18-53

D-18-240

Item #64 (Cont'd)

2

It can be inferred that this was not a malfunction because this period of high  $O_2$  flow was interrupted by cyclic accumulator action,<sup>2</sup> and because the time delay worked properly at all other times including during the accident. It is concluded that this delay system had nothing to do with the cause of the accident.



NATIONAL AERONAUTICS AND SPACE ADMINISTRATION

APOLLO 204 REVIEW BOARD

IN REPLY REFER TO

February 15, 1967

INTEGRATION ANALYSIS SUMMARY

System Affected: Instrumentation Subsystem Item #18  
TPS 054

Observation: Elapsed Time Indicators, post test inspection

Discussion and  
Analysis:

All Elapsed Time Indicators (ETI's) used on S/C 012 which are not qualified as flight hardware and were to be removed prior to flight were inspected after the accident. (Reference TPS S/C 012-054).

Excessive external heat indications were observed on all ETI's but there were no visual indications of short circuits. There were no ETI's installed on the C-band transponder, VHF-FM transmitter or HF transceiver and covers were not installed on the connectors. There were no shorting indications observed in the open connectors.

It is determined that the ETI's inspected did not cause or contribute to the accident.

ENCLOSURE 18-53

D-18-242



NATIONAL AERONAUTICS AND SPACE ADMINISTRATION  
APOLLO 204 REVIEW BOARD

IN REPLY REFER TO

March 7, 1967

INTEGRATION ANALYSIS SUMMARY

System Affected: Environmental Control Subsystem      Item #69  
TPS N/A

Observation: ECS Fire at AiResearch

Discussion and Analysis:

A fire occurred on April 28, 1966 in the AiResearch altitude chamber used to simulate the Command Module while the Apollo Environmental Control System (ECS) was undergoing a mission-life qualification test. The incident took place after completing 480 hours of a scheduled 500 hour test.

The most probable cause of the fire was a failure of the commercial-quality strip heater used to add heat to the steam duct to preclude freezing of water in the duct. A number of commercial grade electrical heater tapes were wrapped around a number of lines as part of the test or support equipment. Heating tape was being used to raise the steam duct temperatures when the incident occurred. The heater tape wire was demonstrated to extrude through the insulation and a fire was initiated under simulated conditions.

It is determined from the above that the ignition source encountered during the ECS qualification incident cannot be associated with the cause of the S/C 012 accident.



NATIONAL AERONAUTICS AND SPACE ADMINISTRATION  
APOLLO 204 REVIEW BOARD

IN REPLY REFER TO

February 17, 1967

INTEGRATION ANALYSIS SUMMARY

System Affected: Communications Subsystem Item #70  
TPS N/A

Observation: VHF-AM receiver failure encountered on S/C 008

Discussion and  
Analysis:

The VHF-AM receiver #1 failed during a thermal vacuum test on S/C 008. The receiver was returned to Collins Radio Company for checkout and found to function normally. Additional investigation of the spacecraft circuitry revealed that the wire harness between the MDE panel 20 receiver select switch and receiver 1 and 2 had been partially cut and some corrosion was noted on the bared conductors. The harness was spliced and additional tests run.

It is determined that this failure has no applicability to S/C 012 and the cause is attributed to a cut wire rather than a system or component.

ENCLOSURE 18-53

D-18-244



NATIONAL AERONAUTICS AND SPACE ADMINISTRATION  
APOLLO 204 REVIEW BOARD

IN REPLY REFER TO

March 7, 1967

INTEGRATION ANALYSIS SUMMARY

System Affected: Environmental Control Subsystem      Item #71  
TPS N/A

Observation: Suit loop return valve leak encountered on  
S/C 008

Discussion and  
Analysis:

During performance of Test #3 on S/C 008, it was noticed that there was atmospheric air in the suit loop (nitrogen contamination) following crew ingress. It was determined that the cabin air entered into the suit loop through the Suit Circuit Return Air Check Valve due to a low  $\Delta$ -P across this valve assembly. A check of the leak specification on the valve assembly showed that the rate of increase of  $N_2$  in the suit loop was within the allowable leakage. A procedure change was made for S/C 012 which required cracking of the Direct  $O_2$  Valve to maintain positive pressure in the suit loop after crew insertion.

It is determined from the above that the leakage problem encountered on S/C 008 cannot be associated with the cause of S/C 012 accident.





NATIONAL AERONAUTICS AND SPACE ADMINISTRATION  
APOLLO 204 REVIEW BOARD

IN REPLY REFER TO

March 4, 1967

INTEGRATION ANALYSIS SUMMARY

System Affected: Stabilization & Control Subsystem      Item #72  
TPS N/A

Observation: Manual Thrust Vector Control (MTVC) Engage  
came on for five seconds on earlier tests  
of S/C 112.

Discussion and  
Analysis:

The MTVC Engage (CH1104) Event Light was seen to  
come on without actuating the translation control  
on the following occasions:

1. During Chamber Pump-Down (40,000 ft.)  
for unmanned altitude run of OCP-K-0034A on  
December 28, 1966. Extinguished after eight  
seconds.
2. During OCP-K-0005A, apparently while the  
crew couches were being moved. The light went  
out with no activity after two seconds.
3. During OCP-K-0005A with no activity in the  
spacecraft. Light went out when SSRP moved the  
crew couches.

On the first occasion, the SCS was in the monitor  
mode with the Delta V Switch "ON". The two other  
times the light was seen, the SCS was in SCS Atti-  
tude Control (Delta V switch - OFF).

An attempt was made to activate the MTVC Engage  
while in the SCS Attitude Control Mode by turning  
the Translation Hand Controller (THC) clockwise  
without success. This action showed that MTVC  
could not have accidentally been activated to cause  
the two indications in OCP-K-0005A (2 and 3 above).

Connectors were wiggled, partially demated and wiggled, and then reconnected in an effort to make the MTVC Mode light come on, but the light stayed out.

With the SCS in the same configuration as it was in OCP-K-0034A (Monitor Mode and the Delta V switch ON), the THC was rotated to MTVC (CW). Observations were made which showed the switch could be detected by other SCS measurements (CH0074 and CH1074 and BMAG outputs). OCP-K-0034A data were reviewed and no activity on CH0074, CH1074, or the BMAG outputs was seen.

Later the Yaw ECA was removed for another problem and the MTVC Engage Signal Conditioner was tested in the Bench Maintenance area and proved to be within specifications. This ECA was then sent to Honeywell for evaluation and the spare Yaw ECA was installed in S/C 012. Threshold level of the PCM system signal conditioner was also tested and found to be in tolerance.

Based on troubleshooting data, the following conclusions have been reached:

1. The MTVC Engage indications in the three instances above were "FALSE" indications since none of the data from OCP-K-0034A or OCP-K-0005A indicated any actual engagement of MTVC (no activity on CH0074, CH1074, or the BMAG outputs.)
2. The malfunction is probably in the harness between the SCS and the PCM system. An intermittent open in a wire or connector would cause the indications.
3. The indication received during the accident in OCP-K-0021 was real. Data review showed activity on CH0074, CH1074, and the BMAG outputs which correlates with the indications received during troubleshooting.



NATIONAL AERONAUTICS AND SPACE ADMINISTRATION  
APOLLO 204 REVIEW BOARD

IN REPLY REFER TO:

April 1, 1977

INTEGRATION ANALYSIS SUMMARY

System Affected: Electrical Power Subsystem Item #14  
TPS N/A

Observation: AC Bus 2 phase C short during prior test  
on Spacecraft 012

Discussion and  
Analysis:

AC Bus 2 phase C shorted during troubleshooting of IDR 039. The short was J39/GSE Pin V to ground and happened while trying to make a voltage measurement on AC Bus 2 phase C. The shorted instrumentation circuit contains a 1/8 amp instrumentation fuse (F5, C14A12). The blown fuse was removed and replaced with a like unit.

Blowing fuse F5 (1/8 amp) in the instrumentation circuit is not considered to be harmful to the AC2 power system. Therefore, it is concluded that this prior concurrence has no correlation with the accident.

ENCLOSURE 18-53

D-18-248



NATIONAL AERONAUTICS AND SPACE ADMINISTRATION  
APOLLO 204 REVIEW BOARD

IN REPLY REFER TO

February 24, 1967

INTEGRATION ANALYSIS SUMMARY

Systems Affected: Sequential Subsystem Item #75  
TPS N/A

Observation: DRS692 dated 11-27-66 indicated that the terminal wires were exposed on the 15 second timer C23K1 relay

Discussion and Analysis: The permanent installation and removal record shows that the time delay module was removed from the C15-1A52 panel; and, without violating electrical connections, the exposed wires were potted, and the module remounted. Since the electrical connections were not violated functional retest of the unit was not required.

Post accident evaluation of the relay has shown that the potting on the relay is intact and that the relay was properly installed.

Data review shows that the relay performed its function (15 second time delay from the time of Oxygen High Flow Rate to Caution and Warning Light Function) properly several times during OCP K-0021-1.



NATIONAL AERONAUTICS AND SPACE ADMINISTRATION  
APOLLO 204 REVIEW BOARD

IN REPLY REFER TO

March 14, 1967

INTEGRATION ANALYSIS SUMMARY

System Affected: Displays and Controls Subsystem

Item #76  
TPS(s) CM-CA-030  
CM-CA-031  
CM-IV-041

Observation: Review of Main Display Console (MDC) Panel  
24 difficulties on S/C 012

Discussion and  
Analysis:

The investigation of MDC Panel #24 was carried out as directed by Board Actions 0145, 0153 and 0160 and in accordance with TPS (s) CM-CA-030, CM-CA-031 and CM-IV-041.

Review of the summary of difficulties which were encountered during fabrication and installation showed that all had been properly dispositioned.

When the MDC Panel #24 was removed and inspected, two areas were observed to require special investigation. These areas were the wire bundles between the Emergency Detection Subsystem (EDS) Power Switch and the Sequence Arm Switches, which showed heat damage and the positioning of the Body-Mounted Attitude Gyro (BMAG) Switch. Discussion and analysis of the BMAG Switch is contained in Integration Analysis Summary Item #99.

Inspection of the wire bundles revealed no visible damage from the burned area to the connectors.

Continuity tests of the panel in the as-found condition showed all normal continuity and circuit resistances. The continuity tests in all other switch positions for Panel 24 also showed normal continuity and circuit resistances.

ENCLOSURE 18-53

D-18-250

Item #76 (cont'd)

2

Analysis of these tests showed that electrical continuity was present after the fire and that no damage of a significant nature had been incurred by the switches, panel wiring or connectors.

It is concluded, accordingly, that the charring of the EDS switch and associated wiring was caused by an external flame source and not by heat generated internally in the switch. In addition, the components of the panel were not a source or a major propagator of the fire.



NATIONAL AERONAUTICS AND SPACE ADMINISTRATION

APOLLO 204 REVIEW BOARD

IN REPLY REFER TO:

April 1, 1967

INTEGRATION ANALYSIS SUMMARY

System Affected: Launch Vehicle Item #77  
TPS N/A

Observation: Three Saturn S-1VB measurement anomalies were noted at 2325:44

Discussion and Analysis: The measurements were:

- (1) LOX tank ullage pressure. EDS #2
- (2) External aft skirt pressure, POS #2
- (3) 5 volt excitation voltage aft

The level of (1) and (2) increased to 100%. (3) increased to the 100% level more rapidly.

The reason for this data change has not been found, but at this time it is felt to be unrelated to the incident. One of the Meas., LOX tank ullage pressure, EDS #2, does interface with the IU and is terminated and open ended in the IU/Spacecraft interface plug.

Due to the large time difference between the time of these transients and the Fire Report, it is unlikely that they have any relation to the accident.

ENCLOSURE 18-53

D-18-252



NATIONAL AERONAUTICS AND SPACE ADMINISTRATION  
APOLLO 204 REVIEW BOARD

IN REPLY REFER TO

March 7, 1967

INTEGRATION ANALYSIS SUMMARY

System Affected: Environmental Control Subsystem      Item #78  
TPS S/C-013

Observation: "Buttermilk Odor" was detected in the Suit Circuit

Discussion and Analysis:

The evaluation of the "buttermilk odor" involved the review of the K-bottle analyses of the O<sub>2</sub> source, the Beckman Analyzer analyses, the gas sample (Watermelon 101) taken at the crew mouthpiece and earlier sample analyses from 8-29-66 to 1-23-67.

The review of the K-bottle analyses revealed no unusual impurities and the gas analyses met specifications as required.

The analyses of gas from the two Beckman Oxygen Analyzers revealed no significant information on "buttermilk odor" and the gas was essentially air.

The gas sample taken at the crew mouthpiece (Watermelon 101) had two analyses. The first analysis revealed approximately 400 ppm of unidentified hydrocarbons which could contribute to an odor condition. A second analysis of the same Watermelon 101 sample was run by the Materials Analysis Branch (KSC) in an effort to identify the hydrocarbons with hopes of isolating suspect materials. This second analysis revealed no useful information due to the dilution of the sample and time span since the sample was taken.



Item #78 (cont'd)

A summary of previous analyses, including earlier manned altitude testing samples, revealed no significant information to identify any "buttermilk odor".

No particular suspect item was identified as emitting a "buttermilk odor" although some of the RTV potting compounds have unique, pungent odors that probably come closest to fitting this odor description. These materials are RTV 510, 577, and 732 which have been used in the spacecraft.

None of the reports of odors discloses any area of suspicion relating to the origin of the odor.



NATIONAL AERONAUTICS AND SPACE ADMINISTRATION  
APOLLO 204 REVIEW BOARD

IN REPLY REFER TO

March 14, 1967

INTEGRATION ANALYSIS SUMMARY

System Affected: Stabilization and Control Subsystem      Item #79  
TPS CM-IV-052

Observation:      SCS Yaw ECA Female Connector J95 had Blackened Areas

Discussion and Analysis:

Spacecraft connector J95, which attached to Yaw ECA mating connector P283, had blackened areas around the receptacles for pins 80, 81 and 82 which appeared to have resulted from arcing. None of these pins saw voltage at the time of the accident.

Connector J95 has been closely examined and the receptacles show to be perfectly clean with no indications of soot.

Mating connector P283 has been closely examined and the interior around the pins shows to be perfectly clean with no indications of soot, arcing burned spots or degradation of the rubber humidity seal.

The history of connector J95 was investigated and it was found that the section which appears to be blackened had been chipped and potted prior to the fire. This potting was done only to continue the humidity seal and was not required electrically.

It has been determined that the potting compound used on connector J95 became heated and discolored during the fire, thus appearing to have been the result of an arcing condition. Two (2) other pins indicated hot spots around the receptacles. These pins were 4 and 42 which are both spares and see no voltage.

The suspected connector had nothing to do with the fire.





NATIONAL AERONAUTICS AND SPACE ADMINISTRATION  
APOLLO 204 REVIEW BOARD

IN REPLY REFER TO

March 9, 1967

INTEGRATION ANALYSIS SUMMARY

System Affected: Electrical Power Subsystem                      Item #81  
TPS    N/A

Observation:                      Gassing characteristics of the pyrotechnic batteries

Discussion and  
Analysis:

The battery complement in the command module consists of three entry batteries and two pyrotechnic batteries. The entry batteries have their individual vents manifolded to an overboard vent line while the pyrotechnic batteries vent into the cabin through their relief valves (cracking pressure set at  $30 \pm 5$  psi).

A preliminary test has been conducted utilizing two pyro batteries, one at normal room temperatures and one at  $105 \pm 5^\circ\text{F}$ . Pressure increase data indicated only a two psi rise during a sixteen (16) day period on the battery at room temperature. The pressure increase on the battery at  $105 \pm 5^\circ\text{F}$  had an estimated worst case rise of approximately 21 psi. (This pressure increase had to be estimated due to an instrumentation malfunction during the first 24 hours of the test.) Based on the above pressures increase and adding 10 psi to simulate flight conditions (15 psia ground level to 5 psia in orbit), only the battery at  $105 \pm 5^\circ\text{F}$  would have vented.

Post test inspection of S/C 012 batteries showed they were electrically functional and there was no physical evidence to indicate the existence of an electrical defect, arcing, or self-provided hot spots.

ENCLOSURE 18-53

D-18-257

Item #81 (cont'd)

2

As the cabin temperature in Spacecraft 012 during the conduct of OCP-K-0021-1 was normal throughout the test until the fire, it is concluded that the pyrotechnic batteries relief valve did not relieve and therefore did not cause the incident.

ENCLOSURE 18-53

D-18-258



NATIONAL AERONAUTICS AND SPACE ADMINISTRATION  
APOLLO 204 REVIEW BOARD

IN REPLY REFER TO

February 23, 1967

INGEGRATION ANALYSIS SUMMARY

System Affected: Stabilization & Control Subsystem      Item #82  
TPS N/A

Observation:      MTVC engaged: 2331:18.5 GMT

Discussion and  
Analysis:

MTVC (manual thrust vector control) is initiated by a clock-wise rotation of the translation controller T-handle. For some unknown reason, the MTVC was engaged at 2331:18.5 GMT. There has been speculation as to how and why it was turned, but the answers are not considered significant. Nothing more can be gained from a study of this item.



NATIONAL AERONAUTICS AND SPACE ADMINISTRATION  
APOLLO 204 REVIEW BOARD

IN REPLY REFER TO

March 1, 1967

INTEGRATION ANALYSIS SUMMARY

System Affected: Crew Station Item(s) #83 & 84  
TPS N/A

Observation: Moderate increase in the Senior Pilot's heart rate at 2330:22 GMT followed by a high increase rate starting at 2331:04 GMT.

Discussion and Analysis:

At 2330:22 GMT there was some change in the respiration pattern and a moderate increase in heart and respiratory rates. These data are consistent with some increase in the Senior Pilot's activity, but do not indicate the degree of activity that would be expected had the Senior Pilot been aware of an emergency situation. At 2330:50 to 2330:55 GMT this data had started returning toward baseline levels.

At 2331:04 GMT there was a marked change in the Senior Pilot's respiration and heart rate. There was also evidence of muscle activity in the EKG trace and evidence of motion in the phonocardiogram. The heart rate continued to climb until loss of signal. This physiological response is compatible with the realization of an emergency situation.

The data obtained from the on-board MDAS tape correlates with the above.



NATIONAL AERONAUTICS AND SPACE ADMINISTRATION  
APOLLO 204 REVIEW BOARD

IN REPLY REFER TO

April 1, 1967

INTEGRATION ANALYSIS SUMMARY

System Affected:

Electrical Power System and  
Scientific Equipment

Item #85  
TPS V16-001-093(MSC)  
CM-CA-074

Observation:

Shorting in the MDAS octopus cable and  
connectors.

Discussion and  
Analysis:

Short circuits were found on the octopus cable near connector J 185. The wiring to this connector provides power and bio-medical instrumentation signals to the Medical Data Acquisition System (MDAS). This cable was subjected directly to the flame within the command module and therefore was badly burned. The power circuit breakers were found open after the fire, however, the MDAS was still operating until cabin rupture. The shorted condition on the octopus cable was between the J 185 connector and the MDAS recorder. The DC wires were also shorted near the left end of the gas chromatograph compartment floor. The shorting on the octopus cable was found to be superficial and a result of the fire.

ENCLOSURE 18-53

D-18-261





NATIONAL AERONAUTICS AND SPACE ADMINISTRATION  
APOLLO 204 REVIEW BOARD

IN REPLY REFER TO

March 7, 1967

INTEGRATION ANALYSIS SUMMARY

Systems Affected: Crew Biomedical - Communications

Item #86  
TPS N/A

Observation: Astronaut shocked during S/C 101 Grw  
Compartment Fit and Functional (C<sup>2</sup>F<sup>2</sup>)

Discussion and  
Analysis:

The subject short circuit experienced in S/C 101 C<sup>2</sup>F<sup>2</sup> at Downey occurred within the crewman's biomedical communications torso harness rather than the cobra cable assembly. This failure occurred because of the following conditions:

1. The torso harness used was of Block I configuration and was in poor condition due to previous usage.
2. The electrical wiring of the Block I harness was not compatible with the Block II biomedical conditioners used. Although the two systems (harness and signal conditioners) will operate properly, a short such as the one which occurred will cause the 16.8 VDC biomed power to be routed to the chest ground electrode on the crewman.
3. The condition of the harness caused a shield to short 16.8 VDC power due to a break in the shield wiring and the ribbon encasing the wiring.

If the same short had occurred in the S/C 012 configuration, the voltage could not have been transferred to the crewman's chest electrode due to these shields not being carried through the harness and signal conditioners on Block I hardware. The only shields on Block I hardware are floating at the DC-DC converter signal conditioner inputs (16.8 VDC power).





NATIONAL AERONAUTICS AND SPACE ADMINISTRATION  
APOLLO 204 REVIEW BOARD

IN REPLY REFER TO

April 1, 1967

INTEGRATION ANALYSIS SUMMARY

System Affected: Environmental Control Subsystem      Item #90  
TPS N/A

Observation: Suit flow indication at low limit for Command Pilot from 2331:18.5 GMT through loss of signal (LOS), Senior Pilot from 2331:18.5 GMT through LOS, and Pilot from 2331:19.6 GMT through LOS

Discussion and Analysis:

Initial review of suit flow PCM data indicated that the final suit flow for the crew members dropped to the lower limit at 2331:18.5 GMT and 2331:19.6 GMT. Further review of the data has revealed that a LOS occurred from 2331:17.4 to 2331:18.4 and that actually all the crew suit flows dropped to the lower limit starting at 2331:16.2 GMT. All suit flows remained at these lower readings until total loss of all S/C communication data. Information concerning crew suit flow indications from 2331:12.9 GMT to 2331:16.2 GMT is contained in Integration Analysis Summary Items #27 and 38.

S/C telemetry data and analytical analysis has determined that the cabin to ECS suit loop differential pressure had increased to 2 psid. This was caused by extremely rapid rate of rise in cabin pressure between 2331:12.4 GMT and 2331:16.2 GMT.

The high differential pressure between the cabin and the suit loop caused the Command Pilot's and Pilot's suit material to be forced against their bodies thereby stopping suit flow.

The Senior Pilot's suit inlet hose was found disconnected following the accident. (Refer to Integration Analysis Summary Items #25 and 102). The aforementioned differential pressure caused cabin atmosphere to reverse the normal flow path and flow back into the ECS suit loop via

the Senior Pilot's disconnected suit inlet hose.

The arresting of suit flow in the Command Pilot's and Pilot's suit and the reverse flow in the Senior Pilot's suit inlet hose caused the suit loop differential pressure (measurement CF 0148) to drop to zero and the suit compressor differential pressure (measurement CF0137) to drop to a low telemetry reading.

The suit loop differential pressure is measured from a point on the suit supply line above the suit flow limiters to a point on the suit return line above the suit compressor. Telemetry data indicated a sharp rise in suit loop differential pressure starting at 23:31.12.4 GMT until 23:31.15 GMT at which time the restricted suit flow caused the suit loop differential pressure to drop to zero.

Based on the above it is concluded that the ECS system continued to operate in the abnormal environment and that the suit flow telemetry data is valid.



NATIONAL AERONAUTICS AND SPACE ADMINISTRATION

APOLLO 204 REVIEW BOARD

IN REPLY REFER TO

March 18, 1967

INTEGRATION ANALYSIS SUMMARY

System Affected: Communication Subsystem

Item #93  
TPS N/A

Observation: Command Pilot had a live microphone

Discussion and  
Analysis:

The actual cause of the open microphone is not known at this time. Analysis was made of voice recordings taken during on-board troubleshooting by the crew and compared with schematic diagrams. This analysis has isolated the cause to the push-to-talk (PTT) or keying line that runs between the Cobra Cable, translation controller, Command Pilot audio control panel and audio center.

1. The separate components have been checked for resistance to ground. All lines measured "open" which is correct.
2. The spacecraft wiring was checked and a 3000 ohm resistance was measured to ground. This 3000 ohm resistance could account for the keyed microphone. However, this resistance could be a result of the fire damage to wire bundles. Later, when an attempt was made to locate the cause of the 3000 ohm resistance, the measurement could not be duplicated. The circuit now measures "open", which is normal.
3. The translation controller PTT button was pushed and released ten times. On the fifth try the button stuck down. If the button had stuck during the S/C-012 test the microphone would remain keyed.

ENCLOSURE 18-53

D-18-266

Post incident review of switch positions in Command Pilot's audio control panel indicate that all switches were in the positions expected. When in this configuration current drawn by the keying line is limited to 20 milliamps at 28 volts. Tests run with a cobra cable show that no sparks were generated with 28 volts and 150 milliamps.

The cause of the live microphone has been attributed to picking up a ground somewhere in the Command Pilot Push-to-Talk circuit in the Spacecraft. The specific source of the ground has not been established. This malfunction, electrical in nature, is not considered to be a fire initiation source. This malfunction may have contributed to the accident, by prompting the crew to be doing some activity to assist in clearing up the overall communications problem.



IN REPLY REFER TO

NATIONAL AERONAUTICS AND SPACE ADMINISTRATION

APOLLO 204 REVIEW BOARD

April 1, 1967

INTEGRATION ANALYSIS SUMMARY

System Affected: Environmental Control Sybsystem

Item #94  
TPS S/C-116  
CM-CA-179

Observation: Initial investigation determined cabin air Fan No. 1 shorted

Discussion and Analysis:

The cabin air Fan No. 1 circuit breakers for AC phases A and C were found to be open after the accident. Also electrical tests of the fan in the spacecraft indicate the shorted phases. Cabin air Fan No. 2 was found to be in satisfactory condition.

Cabin Fans No. 1 and No. 2 are powered by AC bus 1 and AC bus 2, respectively. Twenty-two gauge wires are utilized, and each phase is protected by a 2 amp circuit breaker. The fans are located in the left-hand forward equipment bay.

Continuity tests of the cabin air Fan No. 1 after removal verified that all pin to pin and pin to ground readings at nominal values. The suspected shorts were determined by tests and inspection to be in the power on plug cable.

Based on the above it is concluded that the cabin air Fan No. 1 did not contribute to the cause of the fire. This determination is based upon the lack of fire propagation material in the area. The physical inspection of the fan itself does not indicate it to be the fire initiation source.

ENCLOSURE 18-53

D-18-268



NATIONAL AERONAUTICS AND SPACE ADMINISTRATION  
APOLLO 204 REVIEW BOARD

IN REPLY REFER TO

April 1, 1967

INTEGRATION ANALYSIS SUMMARY

Systems Affected: Electrical Power Subsystem                      Item #95  
Environmental Control Subsystem                                      TPS N/A

Observation: Determine if the teflon wire insulation for the Environmental Control Unit harnesses and the gas chromatograph connector had been etched.

Discussion and Analysis: All teflon insulated wiring is required to be etched prior to potting. Pre-test records were reviewed of the gas chromatograph connector and Environmental Control Unit (ECU) harnesses to determine if they contained teflon wires and if the required etching had been accomplished.

It was determined that etching of the gas chromatograph wires was accomplished. The ECU harness had the latest configuration harnesses which did not require etching.

ENCLOSURE 18-53

D-18-269





NATIONAL AERONAUTICS AND SPACE ADMINISTRATION  
APOLLO 204 REVIEW BOARD

IN REPLY REFER TO

March 14, 1967

INTEGRATION ANALYSIS SUMMARY

System Affected: Electrical Power Subsystem

Item #~~96~~  
TPS CM-IV-110

Observation: Sult current limiter panel short to teleflex cable.

Discussion and Analysis:

An early inspection report disclosed that the teleflex cable may have contacted and shorted the sult current limiter panel. Terminal board 61 was then examined in more detail for evidence of shorting, and the 82556 resistors and conformal coating for overheating. This more detailed examination disclosed that there was no actual contact between the teleflex cable and the terminal board, and that there was no evidence of shorting or overheating.

ENCLOSURE 18-53

D-18-270



NATIONAL AERONAUTICS AND SPACE ADMINISTRATION  
APOLLO 204 REVIEW BOARD

IN REPLY REFER TO

March 14, 1967

INTEGRATION ANALYSIS SUMMARY

System Affected: Electrical Power Subsystem Item #97  
TPS CM-IV-149

Observation: Panel 150 was not properly installed, but lying loose in the Lower Equipment Bay (LEB)

Discussion and Analysis:

Spacecraft panel 150 was electrically mated but not physically installed for the conduct of OCP-K-0021. The panel was inspected as part of the spacecraft disassembly plan (Reference Board Action #0120). The inspection showed that the panel was exposed to high heat as evidenced by considerable sooting and burned wiring. The first three or four inches of wiring from the circuit breakers was burned with exposed conductors on some of the smaller gage wires. The wiring beyond the proximity of the circuit breakers was in good condition, indicating the absence of any sustained overloads. Two wire lugs were bent slightly. There was no evidence of arcing anywhere on the panel or of any material outflow from the components. All physical damage appears to have been caused by the fire. TM data (battery voltages and currents) indicate nominal conditions with the battery system, of which Panel 150 is an integral part. There is, therefore, no evidence which indicates that this panel was a fire cause or propagator.

ENCLOSURE 18-53

D-18-271



NATIONAL AERONAUTICS AND SPACE ADMINISTRATION  
APOLLO 204 REVIEW BOARD

IN REPLY REFER TO

April 1, 1967

INTEGRATION ANALYSIS SUMMARY

Subsystem Affected: Communications Subsystems

Item #98  
TPS CM-CA-002  
005  
61  
65

Observation: Examine cobra cable and pressure garment assembly connectors for arcing and condition of pins.

Discussion and Analysis:

The following cobra cables (V16-601623) were in the spacecraft for OCP-K-0021-1

V16-601623 - 41 S/N 8238 Command Pilot  
- 41 S/N 7384 Senior Pilot  
- 51 S/N 7389 Pilot  
- 51 S/N 0806 Stowed at start of test  
- 51 S/N 0807 Stowed at start of test

During the test cables S/N 0806 and 0807 were unstowed and one was used by the Command Pilot. After the accident one cable was in use at each crew position, one was between the Senior Pilot and Pilot's couches, and one was on the Command Pilot's leg pan. The S/N's cannot be read.

After the accident, the condition of the cable connectors near the dust covers and lanyards was relatively the same condition as the surrounding areas. Connector shells and pins were not fused or otherwise distorted.

A post test check of the cobra cable in use by the command pilot at the start of the test showed that all wiring was in accordance with the drawing and wire list. A microscope examination of the pins showed them to be pitted and corroded.

ENCLOSURE 18-53

D-18-272

Item #98 (Cont'd)

2

A post test check of the cobra cable to which the command pilot switched during the test showed that the wiring was continuous but three shields were missing. A microscope examination showed no pitting or corrosion on the pins.

The sooting of this cobra cable indicated that the command pilot disconnected the cable from the PGA during the accident.



NATIONAL AERONAUTICS AND SPACE ADMINISTRATION

APOLLO 204 REVIEW BOARD

IN REPLY REFER TO

March 14, 1967

INTEGRATION ANALYSIS SUMMARY

System Affected: Stabilization and Control Subsystem Item #99  
TPS CM-CA-030

Observation: Investigation was required to determine  
BMAG Power Switch Position

Discussion and  
Analysis:

The body-mounted attitude gyros (BMAG) power switch, S-19 on panel 24, was found to be in the OFF position after the accident.

To establish the initial position of the BMAG switch, the OCP was reviewed. The switch position was verified during three steps C14-013, -014, and -015 in the OCP to be in its proper (full detent) position at Main Bus B/AC 2.

Post accident inspection of the switch's soot shadow shows evidence of a double position; one faint shadow in the full detent position, and a denser shadow in the false detent position. From these soot shadows it is deduced that the BMAG was in the full detent at the start of the fire and was moved during the fire into the false detent (most likely during attempted egress).

A fingerprint was found on the BMAG switch in the soot. Had the switch been repositioned to OFF during the fire, high temperature, melting and flowing of the switch surface would have destroyed the fingerprint. Therefore, it is concluded that the switch was most probably positioned to OFF by the pad crew during power-down of the spacecraft.

ENCLOSURE 18-53

D-18-274



NATIONAL AERONAUTICS AND SPACE ADMINISTRATION  
APOLLO 204 REVIEW BOARD

IN REPLY REFER TO

April 1, 1967

INTEGRATION ANALYSIS SUMMARY

System Affected: Electrical Power Subsystem

Item #100  
TPS CM-CA-003

Observation: Closeout tape was found on the re-entry battery terminals and other LEB equipment.

Discussion and Analysis: A white closeout tape was placed over the recessed area around the battery terminals to prevent entry of debris.

The tape brand name is "Scotch Cal" manufactured by the 3M Company in accordance with NAA Specification MA-0160-081 and Department of Defense Specification MIL-P-6906.

The flash and fire point of this polyvinyl chloride tape was established by test as 485<sup>o</sup>F. This tape is not included in approved list of spacecraft materials.

Inspection of areas in which the tape was used has determined that the tape did not cause the accident, however, it did support the combustion.

ENCLOSURE 18-53

D-18-275



NATIONAL AERONAUTICS AND SPACE ADMINISTRATION  
APOLLO 204 REVIEW BOARD

IN REPLY REFER TO

March 21, 1967

INTEGRATION ANALYSIS SUMMARY

System Affected: Environmental Control Subsystem      Item #101  
TPS CM-CA122

Observation: Investigation was required to determine if the ECU back pressure control drive motor was installed

Discussion and Analysis: Inspection of the ECU back pressure controller revealed the following:

1. Continuity of the wires, motor and switch checked within specification limits.
2. The switch was verified to be operational.
3. The motor rotates satisfactorily.
4. The motor was covered with soot and corrosion was noted on the glycol fittings.

It is concluded that the ECU back pressure controller did not contribute to the initiation of the fire.



NATIONAL AERONAUTICS AND SPACE ADMINISTRATION  
APOLLO 204 REVIEW BOARD

IN REPLY REFER TO

March 18, 1967

INTEGRATION ANALYSIS SUMMARY

System Affected: Service Propulsion Subsystem      Item #103  
TPS      N/A

Observation:      SPS Chamber Pressure Data showed DC drop

Discussion and  
Analysis:

As the service propulsion subsystem (SPS) chamber pressure, SPO661P, was sampled at a high rate (100 samples per second) during OCP-K-0021, a review of the transducer's circuit response characteristic was made. The primary area of interest for this review was to determine what DC voltage change would cause a perceivable change in the chamber pressure data trace.

The following represents the characteristics of this circuit:

<u>DC Bus Voltage Change</u>	<u>Pc* Output</u>
28V to 17V	No change
28V to 15V	2-10% decrease
28V to 10V for 200ms	No change
28V to 0V for 3ms	glitch
28V to 0V for 10ms	6ms dropout

\*Pc: Chamber Pressure

The data was reviewed in detail during the time of the known AC glitch at 2330:54.85 GMT for correlation of a possible DC voltage dropout. No significant change was noticed.





NATIONAL AERONAUTICS AND SPACE ADMINISTRATION  
APOLLO 204 REVIEW BOARD

IN REPLY REFER TO

March 9, 1967

INTEGRATION ANALYSIS SUMMARY

System Affected: Electrical Power Subsystem      Item #104  
TPS N/A

Observation: Main Battery B loading was indicating at 3.52 amps compared to 1.76 amps and 1.96 amps for batteries A and C.

Discussion and Analysis: Strip chart and tape runs printout of the PCM data relating to the main batteries were reviewed in detail. Pertinent observation was that the early PCM data, when the batteries were known to be on open circuit, showed the following battery currents:

Battery A	0.4 amps
Battery B	1.6 amps
Battery C	0.4 amps

The above values are considered as PCM zeroes.

By subtracting the above indicated PCM zeroes from the data obtained during the test, normal battery behavior data is obtained. It is therefore concluded that the batteries' voltage/current characteristic were normal.



NATIONAL AERONAUTICS AND SPACE ADMINISTRATION  
APOLLO 204 REVIEW BOARD

IN REPLY REFER TO

April 1, 1967

INTEGRATION ANALYSIS SUMMARY

System Affected: Biomed-Communications Suit Wiring      Item #105  
TPS CM-CA-034

Observation: Four shorted wires were found in the communications wiring between the Command Pilot's suit connector and the helmet communications connector.

Discussion and Analysis: Four shorted wires were found in the communications wiring between the suit connector and the helmet communications connector. The wire insulation was discovered to be brittle, discolored and cracked. The wires were identified as microphone signal, microphone signal return, earphone signal and earphone return. Enclosures 18-48 and 18-49 illustrate the shorted condition of the wires.

An intermittent condition was also noted in the 16.8 volt DC biomed power wire in the torso harness between the suit connector and the biomed connector. This condition is considered to be not relevant to the cause of the accident, in that no biomed power was being supplied to the Command Pilot's suit.

The vendors of the torso harness materials have provided the following information:

- (a) The nylon sock around the ribbon cable melts at 480 degrees Fahrenheit.
- (b) The silicone, of which the ribbon is made, melts at 600 degrees Fahrenheit.
- (c) The milene insulation around the wires cracks at 430 degrees Fahrenheit and melts at 480 degrees Fahrenheit.

ENCLOSURE 18-53

D-18-279

Item #105 (Cont'd)

2

From the above information, it is probable that the exterior of the ribbon cable around the area of the damaged wiring was subjected to localized and superficial heat. This would cause damage to the internal wiring insulation without damaging the silicone ribbon.

ENCLOSURE 18-53

D-18-280



NATIONAL AERONAUTICS AND SPACE ADMINISTRATION

APOLLO 204 REVIEW BOARD

IN REPLY REFER TO:

April 1, 1977

INTEGRATION ANALYSIS SUMMARY

System Affected: Electrical Power Subsystem & ECS

Item #106  
TPS CM-IV-068

Observation: DC wiring for environmental system instrumentation burned through

Discussion and Analysis:

The one suspect is wiring providing instrumentation power for some Environmental Control System instrumentation. This wiring contains both DC bus A and DC bus B power, and is located on the Command Pilot side of the Command Module in the vicinity of the Environmental Control Unit and the Lithium Hydroxide Units.

A momentary short could occur in any of four DC bus B or four DC bus A power wires in this wiring. A short would not affect the equipment being powered by these wires, and would not be reflected in any of seven measurement outputs of transducers being provided power because of diode isolation of redundant power for each equipment.

Tests have shown that a short in any of the four DC bus B wires could cause a drop in DC bus B voltage to a low enough level to cause an interruption to inverter 2. Sufficient current could be drawn through any of the eight wires to create an arc of sufficient energy which could ignite debris netting in the immediate vicinity of the wiring.

ENCLOSURE 18-54a

REVIEW OF SPACECRAFT POWER STATUS

I. POWER SOURCES

A. Internal

There are two basic sources of primary electrical power contained in the spacecraft. One is the entry batteries in the command module, and the other is the fuel cells in the service module.

The entry batteries provide power during the entry and landing period of the flight when the command module has separated from the service module. They are also used to augment the other power sources at times when heavy loads are switched on.

The fuel cells are the principal source of internal power for the spacecraft. They provide the main DC power during most of the mission. For much of the ground testing a simulator is used for the fuel cells. This simulator is composed of battery packs which are connected to the fuel cell circuits in the service module by test cables. It simulates the internal power of the fuel cells.

In addition, there are two pyro circuit batteries in the command module for providing power to the pyro devices in the spacecraft. These batteries and battery busses are isolated from the main spacecraft busses. A bus tie switch is provided to permit application of main bus power to the pyro bus in event of pyro battery loss.

B. External

In addition to the internal power system described above, the spacecraft can be powered by a ground power supply via the service module launch umbilical. This source is normally used for all pre-flight testing with a transfer from this external source to the internal source made during the final minutes of the count down.

II. SPACECRAFT DC POWER SEQUENTIAL HISTORY

The spacecraft was powered up at the beginning of the test using a ground power supply connected to the spacecraft via the launch umbilical in the normal external operating mode.

The system for transfer from the ground power supply to the spacecraft fuel cell power supply was tested and operated normally to internal and back to external power at 0938 EST (1438 GMT). Activation and operation of the fuel cells was not a part of this test. A battery pack simulating fuel cells was used in their place.

Fuel cells are not normally used in ground testing because of their limited life. From a DC power point of view, no differences in functions could be expected because of this.

Following the power transfer test, the spacecraft operations were continued using external power. At 2331:12.4GMT and 2331:13.6GMT the command module internal power entry batteries were applied to the command module main DC busses B & A respectively. The batteries were then in parallel with the ground power input in a configuration similar to the normal flight situation where the batteries supplement the fuel cells. Refer to the attached diagram. Command module pressure and temperature instrumentation had previously indicated the presence of the fire.

At 2332:46.4GMT DC ground power was switched off. Various command module systems continued to operate on entry battery power until about 0530GMT (12:30 am EST) on Saturday, when the batteries ran down. Later detailed examination of the spacecraft interior showed the entry battery switches on the control panel in the "on" position.

### III. VERIFICATION OF POWER SEQUENCE

Referring to the diagram, the basic power switching was as follows:

#### Switch "A"

Closed at approximately 10 sec after the crew report of fire. This is verified by an analysis of entry battery and GSE supply voltage and current measurements CC0206V, CC0207V, CC0210V, CC0211V, CC0212V, CC0222C, CC0223C, CC0224C, GC5025C, and GC5029C.

Post inspection verified the switch to be in the Closed position.

Switch "B"

Closed at approximately one hour prior to the crew report of fire (2234:32GMT). This is normal procedure.

Switch "C"

Open since the power transfer test performed about 9 hours earlier. Verified by fuel cell current measurements SC2113C, SC2114C, and SC2115C.

Switch "D"

Closed until approximately 1½ minutes after the crew report of fire (2332:46.4GMT). This was determined by verification of measurement SC2410X.

Switch "E"

Open throughout the test. This switch would only be closed in the event of a pyro battery loss. Post inspection verified the switch to be in the open position.

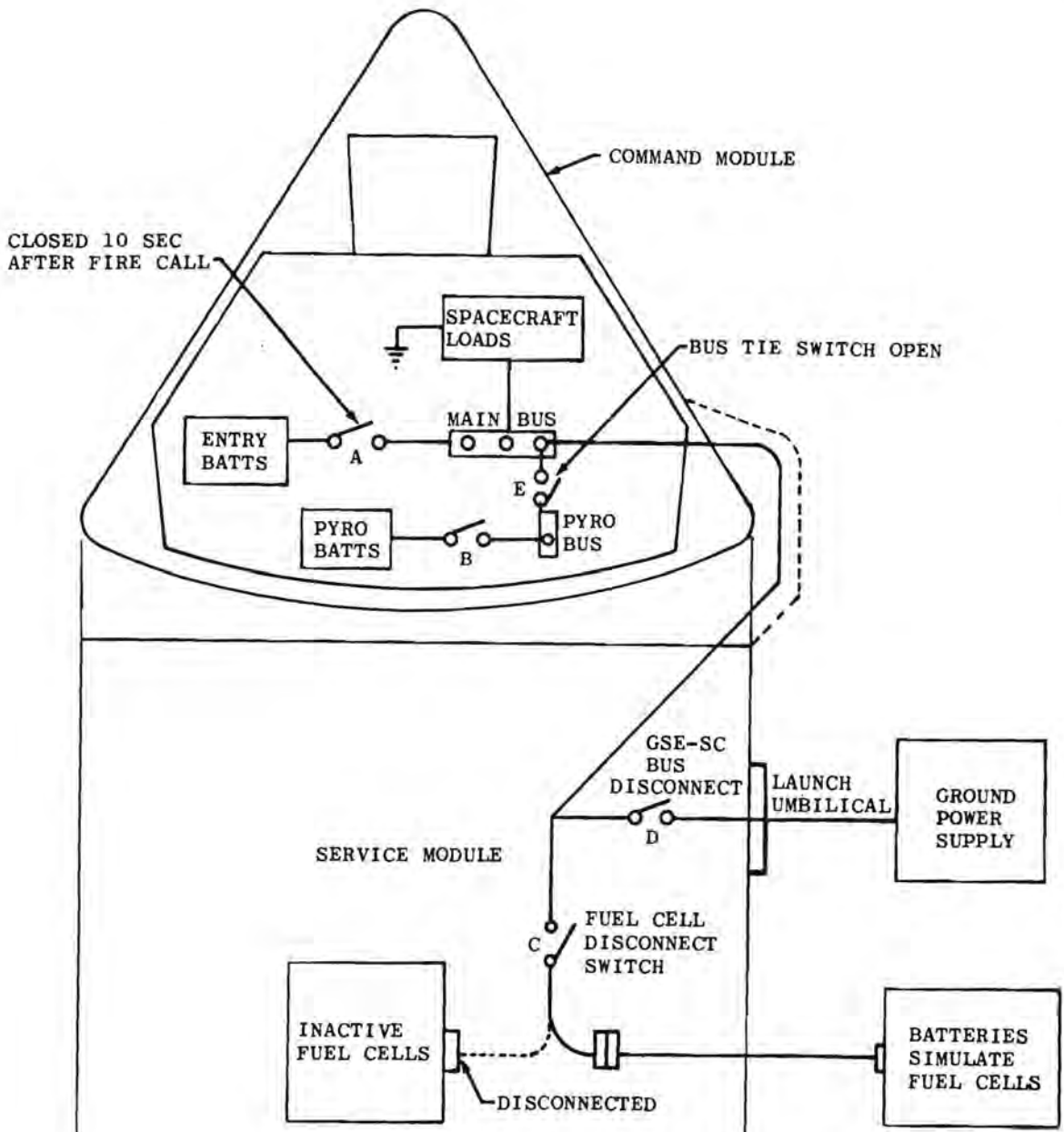

CONFIGURATION OF SWITCHES  
 AT TIME OF FIRE CALL  
 (SIMPLIFIED FOR CLARIFICATION)





NATIONAL AERONAUTICS AND SPACE ADMINISTRATION

APOLLO 204 REVIEW BOARD

IN REPLY REFER TO

February 23, 1967

TO: Panel 18  
FROM: Panel 1  
SUBJECT: SC 012 Electrical Configuration  
(Action Item No.43)

1. At the time of the incident, SC 012 SM jettison controller batteries were installed and electrically connected to the X00-004 circuit breaker box. The two circuit breakers (A&B) were open and consequently there was no power to the jettison controller itself.
2. The following "Q" ball power from the IU stage was turned on at T-45 minutes and remained on through the incident.
  - a. "Q" ball power (+28VDC) - from IU bus 6D21.
  - b. "Q" ball power (+28VDC) - from IU bus 6D41.
3. The following "Q" ball heater power from the IU stage was turned on at T-45 minutes and remained on through the incident.
  - a. "Q" ball heater power (115VAC, 60 cycle).
4. Power (28VDC) at the time of the incident was being applied to the ECS glycol shut-off valve in the SM through the Y00-085 cable from a Harrison lab power supply.
5. MESC indicates power was supplied from the GSE power supply (power supply #5) to the sequential control unit DC bus (28VDC) through the IU umbilical to the spacecraft.
6. SC 012 battery relay bus power at the time of the incident was fed from GSE power supplies #3 and #4 (bus A and bus B power supplies).

ENCLOSURE 18-54B

D-18-286

7. Other power derived from the IU stage:
- a. 6D110 (+28VDC) used to supervise EDS safe A and B in SC.
  - b. 6D91 (+28VDC) used for EDS and is supplied from IU bus 6D11.
  - c. 6D92 (+28VDC) used for EDS and is supplied from IU bus 6D31.
  - d. 6D93 (+28VDC) used for EDS and is supplied from IU bus 6D41.
  - e. Plug supervision bus (+28VDC) supplied by an isolated supply and is used to supervise the mating connectors at the SLA/IU interface (confidence loop).

NOTE: All the above buses were turned on prior to and were on at the time of the incident.

Jesse F. Goree  
Chairman, Panel 1

SUMMARY

<u>SYSTEM</u>	<u>TOTAL</u>	<u>OPEN</u>	<u>CLOSED</u>	<u>DUPLICATE</u>	<u>DELETED</u>
ECS	14	0	14		
G&N	3	0	3		
SCS	3	0	3		
SEQ	1	0	1		
RCS	1	0	1		
COMM	8	0	8		
EPS	16	0	16	8	2
CREW SYSTEMS	<u>1</u>	<u>0</u>	<u>1</u>		
	47	0	47		

SUMMARY OF ECS

POTENTIAL INITIATION THEORIES

ECS-1	WMS Blower as an Ignition Source	Closed
ECS-2	Water Glycol Pumps as an Ignition Source	Closed
ECS-3	Suit Compressor(s) as an Ignition Source	Closed
ECS-4	Cabin Fan(s) as an Ignition Source	Closed
ECS-5	Sponge Material in Waste Management Urine Disposal Lock	Closed
ECS-6	Odor in LEB on 1/25/67 Reported by Technician Changing Flight Qual Recorder Tapes	Closed
ECS-7	Glycol Evaporator Temp Sensor as an Ignition Source	Closed
ECS-8	Suit & Glycol Heat Exchangers' "Sponge" Material as an Ignition Source	Closed
ECS-9	LiOH Absorber Element(s) as Ignition Source	Closed
ECS-10	Plumbing Line Appears "Eaten" through	Closed
ECS-11	Heaters within ECS	Closed
ECS-12	Water Glycol Sample Analyses to Determine Contents	Closed
ECS-13	Crushed "Red Wire" at LiOH Diverter Valve Handle	Closed
ECS-14	O <sub>2</sub> Measurement Sensor	Closed

<u>Total</u>	<u>Open</u>	<u>Closed</u>
14	0	14

POTENTIAL INITIATION THEORIES EVALUATION SHEET ECS-1

SUBJECT WMS Blower as an Ignition Source

SYSTEM OR COMPONENT Waste Management (ECS)

IGNITION SOURCE AND PROPAGATION AC short causing insulation burning.

SUPPORTING FACTORS Difficulty during Spacecraft 008 tests.

NEGATIVE FACTORS Blower not operated during test. Switch "OFF" per  
switch list and found "OFF" following accident.

CONCLUSION WMS Blower removed and visually inspected. Minor sooting  
noted on blower outlet. No evidence of arcing. Blower to be analyzed  
per TPS SC012-CM-CA-242 in MAB. Analysis complete, WMS Blower reclassified  
as non-initiator.

DATE: 3-22-67 STATUS: Non-initiator - Closed

ENCLOSURE 18-55

D-18-290

POTENTIAL INITIATION THEORIES EVALUATION SHEET ECS-2

SUBJECT Water Glycol Pumps as an Ignition Source

SYSTEM OR COMPONENT ECS

IGNITION SOURCE AND PROPAGATION AC short, or AC overload due to  
friction igniting water glycol or insulation.

SUPPORTING FACTORS On last test of spacecraft 008, phases B and C of  
Pump #1 were shorted to ground, and the pump had a cracked cap and  
glycol in the motor.

NEGATIVE FACTORS Data on water glycol subsystem, CF0016, CF0018, CF0019,  
CF0550, CF0549, CF0481, CF0482, CF0483, CF0484, and GSE measurements do  
not support the subject as a source. Plastic pump caps used on 008,  
Inconel on 012.

CONCLUSION Inspection and disassembly show that pumps were  
non-initiator.

DATE: 3-21-67 STATUS: Non-initiator - Closed.

ECS-2

TPS SC012-CM-CA-121 W/G pumps inspection and disassembly has been worked in sufficient depth to enable subject pumps to be reclassified as a non-initiator. Electrical insulation resistance and pin to pin resistance values all were within reasonable limits. Internally the unit was clean. Removal of the motor housing enabled verification of the existence of an inconel bearing housing on both pumps, and also enables verification of the dry condition of the external area thereto.

(This preceding constitutes an interim summary to  
TPS SC012-CM-CA-121)

Rev. 3-22-67

ENCLOSURE 18-55

D-18-292

POTENTIAL INITIATION THEORIES EVALUATION SHEET

ECS-3

SUBJECT Suit Compressor(s) as an Ignition Source

SYSTEM OR COMPONENT ECS

IGNITION SOURCE AND PROPAGATION AC short or bearing overheat due to friction,  
consequently electrical overload.

SUPPORTING FACTORS None

NEGATIVE FACTORS Suit measurements CF0184T and CF1053T do not support the  
suit compressors as an ignition source.

CONCLUSION Suit compressors have been investigated per TPS's SC012-CM-CA-096 &  
098. They are both electrically sound and have been classed as non-initiators.

DATE: 3-21-67 STATUS: Non-initiator - Closed.



POTENTIAL INITIATION THEORIES EVALUATION SHEET ECS-4

SUBJECT Cabin Fan(s) as an Ignition Source

SYSTEM OR COMPONENT ECS

IGNITION SOURCE AND PROPAGATION AC Short burning insulation.

SUPPORTING FACTORS AC short in cabin air fan #1 supply wiring: (1)

Cabin air fans #1 and #2 motor frozen as found during TPS SC012-CM-CA-178

and -179. (2) Motor of fans #1 and #2 frozen to stator due to melted

epoxy used to coat stator.

NEGATIVE FACTORS No shorts in cabin fans. Wiring to cabin fan was

found to have insulation burned off, but did not show evidence of arcing.

CONCLUSION Visual examination showed no evidence of combustion.

Units are classified as non-initiators.

DATE: 3-27-67

STATUS: Non-initiator

- Closed.

POTENTIAL INITIATION THEORIES EVALUATION SHEET

ECS-5

SUBJECT Sponge Material in Waste Management Urine Disposal Lock

SYSTEM OR COMPONENT Waste Management Disposal

IGNITION SOURCE AND PROPAGATION Low auto ignition point of sponge material,

Approx. 240° F.

SUPPORTING FACTORS None

NEGATIVE FACTORS None

CONCLUSION Removed disposal lock is discolored only and has minor sooting on top, apparently from soot settling. Visual inspection reveals no apparent burning from within. UDL has been disassembled, sponge material is undamaged and UDL has been classified as a non-initiator. Ref. TPS SCO12-CM-CA-245.

DATE: 3-21-67 STATUS: Non-initiator - Closed

POTENTIAL INITIATION THEORIES EVALUATION SHEET

ECS-6

SUBJECT Odor in LEB on 1/25/67 Reported by Technician  
Changing Flight Qual Recorder Tapes

SYSTEM OR COMPONENT Unknown (Assigned to ECS)

IGNITION SOURCE AND PROPAGATION Spark igniting volatile O<sub>2</sub> + odor

mixture or spontaneous.

SUPPORTING FACTORS None.

NEGATIVE FACTORS The technician was interviewed and he reported that the

odor similar to ether was detected two days prior to the accident.

No reports of an odor similar to ether were made during the test on

1/26/67 or the day of the accident. A report of MEK (Methyl Ethyl Ketone  
cleaning solvent) was made on the day of the accident at the overboard  
vent.

CONCLUSION No substantiating evidence by physical evidence. Cleaning

solvents could be an initial combustible substance; however, they

would require an initiator.

DATE: 3-27-67

STATUS: Non-initiator

- Closed.

ENCLOSURE 18-55

D-18-296

POTENTIAL INITIATION THEORIES EVALUATION SHEET

ECS-7

SUBJECT Glycol Evaporator Temp Sensor as an Ignition Source

SYSTEM OR COMPONENT ECS (Item 2.49)

IGNITION SOURCE AND PROPAGATION DC short - arc, igniting evaporator wicking.

SUPPORTING FACTORS None

NEGATIVE FACTORS Conflagration in this area should cause CF0018 to rise.

CF0018 did not rise until very late - after fire crew call of fire.

CONCLUSION Sensor has been investigated per TPS SC012-CM-CA-116. Resistance check

is ok and sensor has been determined a non-initiation, TPSSC012-CM-CA-115

investigated evaporator wicking and the sponge material is unburned, and

damp from condensation. Pressure test of evaporator was good. Interim

summaries to these TPS's are written.

DATE: 3-21-67 STATUS: Non-Initiator - Closed

POTENTIAL INITIATION THEORIES EVALUATION SHEET ECS-8

SUBJECT Suit & Glycol Heat Exchangers' Sponge  
Material as an Ignition Source

SYSTEM OR COMPONENT ECS

IGNITION SOURCE AND PROPAGATION Spontaneous - sponge material and  
glycol and/or oxygen.

SUPPORTING FACTORS None.

NEGATIVE FACTORS

CONCLUSION Glycol evaporator sponge material undamaged, damp from  
condensation only, classified as non-initiator. Suit heat exchanger  
visually ok, pressure decay performed, no decay in ten minutes. X-rays  
taken.

DATE 3-21-67

CLASSIFICATION Non-initiator

STATUS Closed.

ENCLOSURE 18-55

D-18-298

POTENTIAL INITIATION THEORY EVALUATION SHEET

ECS-9

SUBJECT LIQH Absorber Element(s) as Ignition Source

SYSTEM OR COMPONENT ECS

IGNITION SOURCE AND PROPAGATION Heat plus volatile gases (methane) retained  
by absorber elements.

SUPPORTING FACTORS

RELEVANT FACTORS CF0184T, Absorber outlet temperature did not rise until very  
late after crew call of fire.

CONCLUSIONS Analyze remains of LIQH absorbers. Absorber elements to be  
investigated locally per TPS SC012-CM-CA-213 and 214. These elements  
are considered low probability initiators.

DATE 3-21-67

STATUS: Non-initiators - Closed

POTENTIAL INITIATION THEORIES EVALUATION SHEET

ECS-10

SUBJECT Plumbing Line Appears "EATEN" Through

SYSTEM OR COMPONENT Within ECU

IGNITION SOURCE AND PROPAGATION \_\_\_\_\_  
\_\_\_\_\_  
\_\_\_\_\_

SUPPORTING FACTORS \_\_\_\_\_  
\_\_\_\_\_  
\_\_\_\_\_

RE FACTORS Line is "Burned" through and is in area of intense heat.

Line previously thought to be elsewhere.

REASON "Line" is on aluminum W/G line not associated with electrical

connection or interface. The fact that it is open in no way can be

considered an initiation source. This item closed as it is an effect,

not a cause.

DATE 3-21-67

STATUS: Non-initiator - closed.

POTENTIAL INITIATION THEORIES EVALUATION SHEET

ECS-11

SUBJECT Heaters Within ECS

SYSTEM OR COMPONENT ECS (General)

IGNITION SOURCE AND PROPAGATION Electrical spark, material unknown.

SUPPORTING FACTORS None

NEGATIVE FACTORS Three ECS heaters (potable H<sub>2</sub>O, steam duct, and urine dump) were all de-energized for this OCP (K-0021). Circuit Breakers for steam duct and urine dump were open per switch list, and found open after fire.  
Steam duct and urine dump heaters are external to pressure vessel.

CONCLUSION No visual evidence found on urine dump or steam heaters to support initiation theory. Potable H<sub>2</sub>O assembly was investigated per TPS SC012 CM-CA-220 and revealed connector pins were corroded but no signs of arcing. thing abnormal was found upon examination of X-Rays. No evidence was found that would indicate the assembly was a potential initiator.

DATE: 3-27-67 STATUS: Non-initiator - Closed



POTENTIAL INITIATION THEORIES EVALUATION SHEET ECS-12

SUBJECT Water Glycol Analyses to Determine Contents

SYSTEM OR COMPONENT ECS

IGNITION SOURCE AND PROPAGATION Water Glycol

SUPPORTING FACTORS

NEGATIVE FACTORS

CONCLUSION TPS #SC012-CM-MA-004 written to perform sample analyses of  
Water Glycol obtained from various sources in the S/C. W/G in itself cannot  
be construed as an initiation source, but certainly a propagator or fuel  
for fire. The W/G fluid is therefore classified as non-initiator.

DATE: 3-21-67 STATUS: Non-initiator - Closed

POTENTIAL INITIATION THEORIES EVALUATION SHEET

ECS-13

SUBJECT Crushed "Red Wire" at LiOH Diverter Valve  
Handle

SYSTEM OR COMPONENT ECS

IGNITION SOURCE AND PROPAGATION \_\_\_\_\_  
\_\_\_\_\_  
\_\_\_\_\_

SUPPORTING FACTORS None  
\_\_\_\_\_  
\_\_\_\_\_

NEGATIVE FACTORS Item mentioned is not a "Red Wire". It is the nylon  
braided cloth handle used to remove the LiOH cartridge.  
\_\_\_\_\_  
\_\_\_\_\_

CONCLUSION This item considered closed.  
\_\_\_\_\_  
\_\_\_\_\_

DATE: 3-21-67

STATUS: Non-initiator - Closed

POTENTIAL INITIATION THEORIES EVALUATION SHEET

ECS-14

SUBJECT O<sub>2</sub> Flow Rate Sensor

SYSTEM OR COMPONENT ECS

IGNITION SOURCE AND PROPAGATION Component DC short, burning wire and propagating therefrom.

SUPPORTING FACTORS Hi O<sub>2</sub> flow indication.

NEGATIVE FACTORS Data analysis of CF0035, CF0036, CF0135, CF0136, and CF0137 indicate Hi demand of O<sub>2</sub> flow.

CONCLUSION See attached.

DATE: 3-21-67 STATUS: Non-initiator - Closed  
(For associated wiring see EPS-3)

ECS-14 O<sub>2</sub> Flow Rate Sensor:

Crew movement and apparent suit leakage has been correlated for 3 periods of Hi O<sub>2</sub> flow with gimbal angle and biomed data. Fire periods of Hi O<sub>2</sub> flow have been definitely correlated with periods of great crew activity (Cobra cable for instance).

The final Hi O<sub>2</sub> flow has been correlated with gimbal angles and biomed data, and the conditions analyzed lead to the conclusion that the O<sub>2</sub> flow transducer was giving valid data and that there was indeed a demand on the oxygen by the crew due to increased activity. The fact that a C&W signal was obtained from Hi O<sub>2</sub> flow 15 seconds after CF0035Q reached saturation at 23:30:59.4 GMT substantiates the conclusion that the flow transducer did not fail and was giving valid data at the time of C&W stimulation at 23:31:15 GMT.

B. High Oxygen Flow Rate

Telemetered data indicate that the high oxygen flow rate conditions for the last 30 seconds before the fire call can be attributed to the apparent high level of prime suit leakage at low suit-to-cabin differential pressure, magnified by apparent crew activity.

There has been considerable speculation as to whether the high flow could be indicative of a sensor and/or associated wiring difficulty.

The oxygen flow sensor circuit includes two separate outputs. The signal circuit going to the Pulse Code Modulation Telemetry System (PCM) is conducted to the PCM system through a twisted shielded pair of wires. A short circuit between the signal lead and either the return wire or the shield braid would cause a zero output (no flow) reading on the oxygen flow indication. It is highly improbable that any short circuit between the signal lead and a 28 volt DC supply lead could occur without a prior short circuiting to the ground lead or shield lead.

The second output from the oxygen flow sensor circuit goes to a time delay relay to indicate high flow alarm. It is on the ground circuit return side of the relay. A ground circuit completion is required to indicate high oxygen flow. This is supplied from the signal circuit going to PMC, and a ground on this line could not affect the PCM flow rate indication.

Single failures could exist within the bridge circuitry controlling the flow sensor which would indicate high flow rates on both the PCM output and the signal to the relay. These, however, will require examination of the oxygen flow sensor box to confirm or deny this possibility. A preliminary examination disclosed shorts to ground in the flow sensor; shorts to ground will produce a zero or no flow output indication. The flow sensor box is being torn down at the present time. It should also be noted that the location of the oxygen flow sensor was a high fire damage area, and that the sensor would be expected to be damaged by the fire.

Based on the above, it is concluded that the high oxygen flow data indication was valid, and that there was no malfunction of the sensor and/or associated wiring prior to the fire call.

SUMMARY OF G&N

POTENTIAL INITIATION THEORIES

G&N-1	Crew Member Motion Striking Electrical Component, Such as Panel, Connector	Closed
G&N-2	Eye Piece Stowage Unit, Heater Wire Routing G&N, LEB, Optics Stowage & Cond. Enunciator Panel	Closed
G&N-3	PSA Tray Short Circuit	Closed

<u>Total</u>	<u>Open</u>	<u>Closed</u>
3	0	3

POTENTIAL INITIATION THEORIES EVALUATION SHEET

G&N-1

SUBJECT Crew Motion Striking Electrical Component  
Such as Panel, Connector, Etc.

SYSTEM OR COMPONENT Unknown

IGNITION SOURCE AND PROPAGATION Electrical short circuit - many potential  
fuel sources.

SUPPORTING FACTORS IMU gimbal T/M voltages CG2140 and 2170 reflect  
sharp vehicle motion at 23:30:54.9 coincident with AC-2 Glitch and Gas  
Chromatograph trace deflection.

NEGATIVE FACTORS

CONCLUSION Crew activity data are being utilized as supporting data in  
the evaluation of event time line. May be the cause of initiation. Physical  
evidence of arcing or wire damage is reported on specific items.

(Reference EPS-2, EPS-3, EPS-14, EPS-22, EPS-26, COMM-1)

DATE: 3-21-67 STATUS: Non-initiator - Closed



POTENTIAL INITIATION THEORIES EVALUATION SHEET G&N-2

SUBJECT Eye Piece Stowage Unit, Heater Wire Routing

SYSTEM OR COMPONENT Optics Heaters or Heater Wires

IGNITION SOURCE AND PROPAGATION Possible failure of heater thermostat,

short in heaters or wiring, initial fuel ESU Royalite cover, decal & foam.

or failure related to enunciator lights.

SUPPORTING FACTORS (1) Materials are combustibile with a propagation rate greater

than 2.5 inch/second from flammability test results. (2) SCT Eye piece

cover found on C/M floor. (3) Scratches on Optics shroud. (4) Eye

piece heater blanket and storage area damage. (5) G&N verb code decals

were added to S/C configuration the morning of the incident.

(6) Condition enunciator gimbal lock lite reads 3 ohms.

NEGATIVE FACTORS Eye piece heaters and thermostats checked ok, with no

Propagation path.

Condition enunciator gimbal lock lite resistance value

was verified to be nominal.

SCT eye piece cover may have been attached to Velcro by splt

prior to incident. The cover dropped from Velcro after fire started.

CONCLUSION Close this item as an initiator. No source of ignition could

be found in the electrical wiring or heaters and lights.

DATE: 3-23-67

STATUS: Non-initiator - Closed

POTENTIAL INITIATION THEORIES EVALUATION SHEET

G&N-3

SUBJECT PSA Tray Short Circuit

SYSTEM OR COMPONENT G&N PSA

IGNITION SOURCE AND PROPAGATION Nickel ribbon wire in module assembly

of PSA, potted in urethane foam.

SUPPORTING FACTORS Previous experience of PSA tray short circuit causing

ignition of foam (ambient air).

NEGATIVE FACTORS Inspection of PSA trays indicates no internal ignition

of tray modules.

CONCLUSION Item closed after visual inspection of trays verified no

ignition source in the modules.

DATE: 3-21-67 STATUS: Non-initiator - Closed

SUMMARY OF SCS, SEQ, & RCS

POTENTIAL INITIATION THEORIES

SCS-1	Rotation Control Electrical Short	Closed
SCS-2	Translation Control Electrical Short	Closed
SCS-3	BMAG Power Switch Panel #24 Short	Closed

<u>Total</u>	<u>Open</u>	<u>Closed</u>
3	0	3

SEQ-1	Panel 10 and 11 Component Failure	Closed
-------	-----------------------------------	--------

<u>Total</u>	<u>Open</u>	<u>Closed</u>
1	0	1

RCS-1	Panel 12 RCS C/M-S/M Indicator Switch Failure	Closed
-------	---	--------

<u>Total</u>	<u>Open</u>	<u>Closed</u>
1	0	1

POTENTIAL INITIATION THEORIES EVALUATION SHEET

SCS-1

SUBJECT Rotation Control Electrical Short

SYSTEM OR COMPONENT SCS

IGNITION SOURCE AND PROPAGATION Electrical short.

SUPPORTING FACTORS Case was warped and the cable was badly burned

near the rotation control.

NEGATIVE FACTORS Data review, continuity check, visual and physical  
examination of the rotation control and associated wiring show no anomalies  
as a fire cause. Ref. TPS PIB-004, 007; CM-IV-077

CONCLUSION No evidence has been found from hardware or data examination  
that would indicate this component or its associated wiring was a cause or  
propagator of the fire.

DATE: 3-21-67 STATUS: Non-initiator - Closed

POTENTIAL INITIATION THEORIES EVALUATION SHEET

SCS-2

SUBJECT Translation Control Electrical Short

SYSTEM OR COMPONENT SCS

IGNITION SOURCE AND PROPAGATION Electrical short

SUPPORTING FACTORS Problems during test with push-to-talk communications  
circuit. Also fracture in case,

NEGATIVE FACTORS Data review, continuity and insulation resistance check,  
and physical examination show no anomalies as a fire cause (ringout  
of associated S/C wiring showed no anomalies). Ref. TPS PIR-002,  
003, 005, C/M-IV-058

CONCLUSION No evidence has been found from hardware or data examination  
that would indicate this component or its associated wiring was a cause  
or propagator of the fire.

DATE: 3-21-67 STATUS: Non-initiator - Closed



NATIONAL AERONAUTICS AND SPACE ADMINISTRATION  
APOLLO 10 REVIEW BOARD

IN REPLY REFER TO

March 9, 1967

TO: A. D. Mardel, Chairman, Panel 18  
FROM: C. L. Creech, Displays & Controls Subsystem Manager  
SUBJECT: Main Display Console Panel Number 24

Detailed investigation of the subject panel was conducted in accordance with TPS CM-CA-030 and TPS CM-CA-031.

The Analytic Report of the above is forwarded herewith for your information and retention.

*Carlton L. Creech*  
Carlton L. Creech  
Integration and Analysis Panel  
(Panel 18)

Enclosure

ENCLOSURE 18-55

D-18-315

POTENTIAL INITIATION THEORIES EVALUATION SHEET

SCS-3

SUBJECT BMAG Power Switch Short

SYSTEM OR COMPONENT SCS - Panel #24

IGNITION SOURCE AND PROPAGATION AC short, DC short, or arcing

SUPPORTING FACTORS Switch found in OFF position - S/B AC-2. Also light  
area on panel indicates a possible "false detent" position.

NEGATIVE FACTORS Data review and performance of TPS CM-CA-030 and -031  
showed no anomalies as a fire cause. See attached report for complete  
analysis of BMAG Switch and Panel #24.

CONCLUSION No evidence has been found from hardware or data examination  
that would indicate this component was a cause or propagator of the fire.

DATE: 3-21-67 STATUS: Non-initiator - Closed

ENCLOSURE 18-55

D-18-316

AS 204 ANALYTIC REPORT  
MAIN DISPLAY CONSOLE PANEL #24

References:

1. TPS CH-CA-030
2. TPS CH-CA-031
3. V16-771424 - Panel Assembly Drawing
4. V16-976716 - Panel Schematic Drawing
5. Photographs - E-5C-21  
62-107C-4 through 6  
122-306C-12  
122-308C-1  
123-307C-5, 6  
123-309C-1 through 6

  
C. W. Fischer  
Systems Engineer  
MAA/SH1D

  
G. L. Creech  
Systems Engineer  
NASA/HSC



#### Abstract

Main Display Console Panel #24, Mission Sequence Control, as removed from S/C 012, presented two areas of special interest for detailed investigation. Soot shadowing on the panel gave evidence that the BMAG power switch, S-39, had been moved after the fire. Charring was present on one corner of the EDS power switch, S-1, and immediately associated wiring. Additionally, the integrity of all other switches and wiring on the panel was of interest.

Conclusions are that the BMAG switch was moved by accidental contact during the fire and again after the fire during power shut off; the EDS switch was charred by externally applied, locally concentrated, heat; the switch and associated wiring are electrically sound and functional; all other switches and wiring on the panel are electrically sound and functional.

#### Introduction

As removed from S/C 012, MDC Panel No. 24 was observed to have two areas requiring special investigation. The EDS Power switch, S-1, and its attached wiring were charred at one corner. The BMAG Power switch, S-39, was in OFF position as removed but the scot outline of the knob on the panel indicated that the switch had been in the AC-2 position in either the full, or "false", detent position (Ref. Photograph E-5C-21). Additionally, it was desirable to investigate the electrical and functional integrity of all of the switches and panel wiring.

#### Description of Tests

Tests were performed in accordance with TPS CM-CA-030 and TPS CM-CA-031 to determine the electrical integrity of all switches, panel wiring, and connectors in all positions of all switches. Special tests were performed to determine the effect of placing the rotary switches in "false" detent positions.

Detailed examination was made of the BMAG Power switch to determine the actual position of the switch during the various phases of the fire.

Record: was made of a fingerprint found on the BMAG Power switch knob. (Ref. Photograph 123-309C-6.)

#### Test Results

The continuity tests of the panel in the as-found condition showed all normal continuity and circuit resistances.

The continuity tests in all other switch positions showed all normal continuity and circuit resistances.

The continuity tests of the rotary switches in the "false" detent positions showed that, with the exception of the BMAG Power switch, all continuities and circuit resistances were the same as in the full detent positions. In the AC-1 "false" detent position, the BMAG Power switch continuity and circuit resistances were the same as the full detent position. In the AC-2 "false" detent position, the AC circuits were closed through the switch but the DC circuit was open.

During initial examination of the soot shadow of the BMAG Power switch, a fingerprint in soot was noted on the switch knob (Ref. Photograph 123-309C-6). Prior to any manipulation of the switch, the fingerprint was photographed and "lifted" by the FBI.

The soot shadow of the BMAG Power switch knob was compared with those of other rotary switch knobs on Panel #24 (Ref. Photograph E-5C-21). It was noted that the TVC-1, Partial SCS Power, and Rate Gyro switch knobs had soot patterns that are broad in outline at the indexing point of the knob and follow the knob contour closely. The BMAG switch knob outline is pointed at the indexing point of the knob and smaller in outline than the knob. There is evidence of a double shadow of the BMAG Power switch knob. (See Photographs E-5C-21 and 123-309C-6.)

#### Analysis of Tests

The panel electrical continuity and resistance measurements showed that electrical continuity was present after the fire and that no damage of significant nature had been incurred by the switches, panel wiring, or connectors.

In analyzing the BMAG Power switch positions, several areas were investigated.

To establish the initial condition of the switch, Operational Check-out Procedure (OCP) K-0021 was examined. During performance of Steps 14-013 of this procedure, a Master Alarm is obtained when the BMAG switch is turned to AC-2. This was obtained thus indicating that the DC circuit was closed through the switch. Simultaneously, an indication of AC circuit switch closure appeared as Step 14-014 on the T/M record. Step 14-015 indicated satisfactory operation after warmup by confirming that the AGAP Temperature Indication in the Caution & Warning Annunciator Matrix on Panel #10 did extinguish.

As noted above, the BMAG, DC heater circuit is not closed through the switch in the "false" detent position.

The soot shadow of the knob on the panel shows evidence of a double shadow with one faint shadow in the full detent position and a denser shadow in the "false" detent position (Ref. Photograph 123-309C-6). When the switch is placed sequentially in these positions, the pointed shadow conforms closely to the overlapped outlines of the knob.

From these facts, it is deduced that the switch was in the full detent position at the initiation of the fire and was later, during fire, moved to the "false" detent position.

In considering the difference between the switch position as indicated by the panel soot shadow, and the OFF position, in which it was found when removed from the spacecraft, the fingerprint on the knob is of significance. The surface of the mylar knob was melted and bubbled indicating that the temperature at its surface had been over 500°F. The high temperature and melting and flowing of the knob surface would have destroyed any fingerprint made prior to the fire. The fingerprint on the knob was in soot and, as determined in the process of "lifting" it, entirely on the surface of the knob material.

It is deduced from this that the switch was operated after the fire to move it from the AC-2 "false" detent position to the OFF position. This action was most probably taken by the pad crew during power-down of the spacecraft.

#### Conclusions

It is concluded that operation and functioning of all switches on Panel #24 were normal throughout the fire. The components of the panel were not a source or a major propagator of the fire.

The charring of the EDS switch, S-1, and associated wiring, was caused by an external flame source and not by heat generated internally to the switch.

The different positions of the BMAG Power switch have been determined, or are deduced, to be:

1. Full detent AC-2 - at fire initiation.
2. "False" detent AC-2 - sometime during the fire.  
NOTE: It is postulated that during the fire the commander contacted the switch with his left foot during attempted egress. During the Mockup #2 exercises, it was noted that the commander's left foot did come very close to Panel #24 during the egress maneuver.
3. OFF - after fire during power-down.

POTENTIAL INITIATION THEORIES EVALUATION SHEET

SEQ-1

SUBJECT Panel 10 and 11 Component Failure

SYSTEM OR COMPONENT Sequencers

IGNITION SOURCE AND PROPAGATION Spontaneous - heat and glycol

SUPPORTING FACTORS Digital Event Timer (DET) on Panel 11 as experienced running hot during operations. If a glycol leak developed from the cold plate, leaking on the DET, it could cause fire.

NEGATIVE FACTORS See attached sheet

CONCLUSION The DET, or other components mounted on Panels #10 and #11 was neither an ignition source nor a propagator for the fire.

DATE: 3-21-67 STATUS: Non-initiator - Closed

PANEL 10 AND 11NEGATIVE FACTORS

Panels #10 and #11 were visually inspected. There is no evidence that the Digital Event Timer (DET) on Panel #11 was running hot. This instrument normally dissipates approximately 4 Watts and consequently has a temperature rise of only 2-3 degrees F. The backpotting of the DET was inspected and found to be sound. It is lightly sooted but still transparent enough to allow the wire connections to the header to be seen. The wire harness has no evidence of overheating and has only a light soot deposit. The panel connector is clean and the pins are straight and clean. The DET is hermetically sealed. There is no evidence that the seal is broken. The digit wheels are visible through a light soot deposit on the cover glass. There is evidence of water glycol drip on the DET case behind the panel. However, the water glycol drip has washed away some of the soot deposit and appears to have occurred late in the progress of the fire. The C&W matrices on Panels #10 and #11 were examined. The backs of these matrices were lightly sooted but had no evidence of overheating. The cable harnesses and connectors were clean and in good condition. The legend plates on the panel side of the matrices were sooted but the glass covers were all intact and the legends legible. Some deterioration of the RTV Silicone rubber potting material is evident on the matrix around the panel openings where a flue effect allowed hot gases to pass between the panel edge and the matrix edge. However, the matrix bodies are intact and are not distorted. There is no evidence of water glycol drip in the matrices.

POTENTIAL CAUSATION THEORIES EVALUATION SHEET

RCS-1

SUBJECT Panel #12 RCS C/M-S/M Indicator Switch

SYSTEM OR COMPONENT RCS

IGNITION SOURCE AND PROPAGATION Spark or heat plus glycol. DC short or  
spontaneous.

SUPPORTING FACTORS (1) Panel #12 switch (S-2) just completed potting still in  
cure cycle. (2) Official last switch moved per OCP prior to fire.  
(3) This switch is located in a heavy fire damaged path looking at the  
exterior of the MDP to the command pilots couch.

NEGATIVE FACTORS See attached sheet

CONCLUSION The Panel #12 S-2 switch was neither an initiator or a propagator of  
the fire.

DATE: 3-21-67

STATUS: Non-initiator

- Closed

## PANEL #12 RCS C/M-S/M INDICATOR SWITCH

NEGATIVE FACTORS

Visual examination of Panel #12 S-2 back potting showed no damage other than light soot deposit. Potting material is still transparent and wire connections to switch terminals are visible through the potting material. The switch is hermetically sealed and all make and break contacts are within the sealed enclosure. The terminals are brought out through a metal-glass header to which the wiring is soldered. The solder connections are then covered with the potting material to protect the joints and terminals from exposure to the C/M atmosphere. The wire harness to S-2 and the associated connector are in good condition with only light soot deposits and no evidence of overheating. The connector interface is clean and the pins are all straight and clean. There is no evidence that the switch, or its associated wiring, were overheated. There is nothing to indicate that the switch, or associated wiring, were ignition source of a propagator of the fire.

SUMMARY OF COMM

POTENTIAL INITIATION THEORIES

COMM-1	MDAS Octopus Cable Connector Short	Closed
COMM-2	Teleflex Cable Short to TB 61-7	Closed
COMM-3	Overheating of Crewman's Electrical Assembly	Closed
COMM-4	Disconnect Spark on 0.020 Milliamp Lines	Closed
COMM-5	RF Power	Closed
COMM-6	USBE Potting Burned	Closed
COMM-7	Shorts in Biomed-Comm Suit Wiring	Closed
COMM-8	MDAS-LEM Recorder Signal Wires Short	Closed

<u>Total</u>	<u>Open</u>	<u>Closed</u>
8	0	8



POTENTIAL INITIATION THEORIES EVALUATION SHEET COMM-1

SUBJECT MDAS Octopus Cable Connector

SYSTEM OR COMPONENT Biomed - Experiments

IGNITION SOURCE AND PROPAGATION Octopus cable 28 VDC shorting to ground caused  
by crewman deforming P-185 connector on scientific compartment "A" panel.

Propagation via material on crewman's shoe, connector insert, sleeve,  
wire insulation.

SUPPORTING FACTORS 28 VDC from Bus B is available at J185 connector. CB 117  
on panel 22 open and heavily sooted. This is CB feeding MDAS power.

NEGATIVE FACTORS MDAS data would have indicated a short if power had dropped  
below 19 VDC for 25 milliseconds or longer. Data does not indicate this  
occurred.

CONCLUSION Arcing was superficial, appears to be a result of the fire  
and not a cause.

DATE: 3-21-67 STATUS: Non-initiator - Closed

POTENTIAL INITIATION THEORIES EVALUATION SHEET

COMM-2

SUBJECT Teleflex Cable Short to TB 61-7

SYSTEM OR COMPONENT EPS

INITIATION SOURCE AND PROPAGATION Cable shorts TB 61-7 to ground causing 28 volt  
drop thru 825 ohms wire wound 2 watt resistor. Propagation via resistor  
heating up and igniting conformal coating which in turn ignites debris  
trap net.

SHORTING FACTORS

NEGATIVE FACTORS (1) Continuity check TB 61-7 to ground.  
(2) Visual examination of resistor R7

CONCLUSION TPS CM-IV-110 dated 3-14 references TB 61-7. Resistance checks and  
visual inspection concluded no shorting or grounds on terminal board. The  
soot was brushed away from the connector and physical inspection resulted  
in no indication of short.

DATE: 3-22-67 STATUS: Non-initiator - Closed

POTENTIAL INITIATION THEORIES EVALUATION SHEET      COMM-3

SUBJECT Overheating of Crewman's Electrical Assembly  
(Cobra Cable, T Adapter, Noise Eliminator & PGA)  
SYSTEM OR COMPONENT      COMM

IGNITION SOURCE AND PROPAGATION      Short inside umbilical could cause  
overheating of assembly. Propagation from potting compound of crewman's  
umbilical or portions of crewman's suits.

SUPPORTING FACTORS      1. Suits appear burned.  
2. Crewman had changed umbilical to attempt to  
repair live mike condition.

NEGATIVE FACTORS      1. Replacing to new cable did not repair live mike  
condition.  
2. All leads into umbilical are current limited.

CONCLUSION      TPS CA-075, CM-CA-002, 005, 065, 061. These TPS's tested for  
shorts, grounds, material analysis, and x-rays. All Showed no anomalies  
that could cause incident. Physical examination did not disclose any  
evidence of arcing or fire initiation.

DATE:      3-21-67      STATUS:      Non-initiator      -      Closed

POTENTIAL INITIATION THEORIES EVALUATION SHEET

COMM-4

SUBJECT Disconnect Spark on .020 Millamp Lines

SYSTEM OR COMPONENT Telecommunications

ON SOURCE AND PROPAGATION Connector of crewman umbilical was

disconnected to replace umbilical cable. Propagation from connector

insert or umbilical potting compound

SUPPORTING FACTORS Crew thought they were having trouble so they replaced

umbilical. The new umbilical did not clear fault symptom.

NEGATIVE FACTORS 1. Disconnect was approximately 20 minutes prior to fire call.

2. Tests ran in O<sub>2</sub> atmosphere showed no appreciable spark

at even higher currents.

CONCLUSION As a result of above test, the conclusions are that no appreciable

spark caused by disconnect can be determined as cause of incident.

DATE 3-21-67 STATUS: Non-initiator - Closed

POTENTIAL INITIATION THEORIES EVALUATION SHEET COMM-5

SUBJECT RF Power

SYSTEM OR COMPONENT RF Systems

IGNITION SOURCE AND PROPAGATION RF radiated energy produces adequate  
temperature rise to ignite materials. Requires an open RF lead  
inside the cockpit. Propagation via any combustible near or around  
the S/C RF coax lines.

SUPPORTING FACTORS Very few, if any. However, adequate RF energy was  
available in the UHF/FM system and the C-Band system coaxes.

NEGATIVE FACTORS It would require a broken coax. It would require a  
combustible material in the broken coax area. It would require a  
unique set of conditions to produce a temperature rise in the material.  
PCM data indicates normal operation.

CONCLUSION Visual inspection of S/C coax, Ant's and coax switches show  
no evidence of arcing or shorting. C-Band, S-Band, and VHF/FM  
continued to radiate after LOS period.

DATE: 3-22-67 STATUS: Non-initiator - Closed

POTENTIAL INITIATION THEORIES EVALUATION SHEET

COMM-6

SUBJECT USBE Potting Burned

SYSTEM OR COMPONENT Telecommunications

IGNITION SOURCE AND PROPAGATION ISBE (Unified S-Band Transponder) may have

had internal short. Propagation via potting material inside USBE.

SUPPORTING FACTORS USBE potting is burned in blow hole fashion.

NEGATIVE FACTORS USBE transmissions continued well into general fire time.

Carrier continued after voice and data terminated.

CONCLUSION Visual, resistance, and functional tests of USBE completed.

No anomalies observed that could cause incident . USBE classified to

"B" category.

DATE: 3-21-67

STATUS: Non-initiator - Closed

ENCLOSURE 18-55

D-18-331

POTENTIAL INITIATION THEORIES EVALUATION SHEET

COMM-7

SUBJECT Shorts in Biomed-Comm Suit Wiring

SYSTEM OR COMPONENT Biomedical - Communications

IGNITION SOURCE AND PROPAGATION DC from S/C to suit to ground

Propagation via suit and suit wiring

SUPPORTING FACTORS None - Six shorted wires in communications portion of suit wiring. Possible supporting evidence in communications anomalies.

Insulation around wires was more affected by heat than cable sheathing.

NEGATIVE FACTORS Normal operation of components using these wires use only low currents of insufficient energy to create arc which would cause ignition(200<sup>o</sup> F) in suit. Type of cable used has fairly low heat resistant insulation with higher temperature (600<sup>o</sup> F) material used in the outer sheath.

CONCLUSION Shorting and damage is apparently due to external heat and burning.

DATE: 3-23-67 STATUS: Non-initiator - Closed

ENCLOSURE 18-55

D-18-332

POTENTIAL INITIATION THEORIES EVALUATION SHEET COMM-8

SUBJECT MDAS-LEM Recorder Signal Wires Short

SYSTEM OR COMPONENT Experiments - MDAS

IGNITION SOURCE AND PROPAGATION Short circuit on MDAS signal wires to LEM

voice recorder, propagation via debris traps.

SUPPORTING FACTORS None

NEGATIVE FACTORS These wires carry 100 PPS IRIG B timing of 5 Volts

peak-to-peak.

CONCLUSION TPS CM-CA-076 duplicated suspected short on signal wires which

did not draw excessive current. MDAS functioned normally.

DATE: 3-22-67 STATUS: Non-initiator - Closed



SUMMARY OF EPS  
POTENTIAL INITIATION THEORIES

EPS-1	Gas Chromatograph Cable Short (Ref. EPS-2)	Duplicate
EPS-2	Gas Chromatograph Connector Short & Cable Short	Closed
EPS-3	Damaged Wire Harness Under LiOH Door	Closed (Probable Initiator)
EPS-4	Damaged Wire (1C50A16) Near J-Box C15-1A52 (Screwdriver Incident)	Closed
EPS-5	Teleflex Cable Shorting Resistor R7 at C15A7TB61-7 (Reference to COMM-2)	Duplicate
EPS-6	Electrical Short Due to Cold Flow Characteristics of Teflon Wire	Delete (General Category)
EPS-7	Q-Ball Wiring Short	Closed
EPS-8	CB64 on Panel 25 (SCS GRP 2 MNB) Rubbing Against Wire Harness	Closed
EPS-9	Tapes on Entry Batteries (White Room Tape)	Closed
EPS-10	Pyro Batteries Vented to Cabin	Closed
EPS-11	Cabin Fan Failure (Reference ECS-4)	Duplicate
EPS-12	Suit Compressor Overloaded (Reference ECS-3)	Duplicate
EPS-13	Inverter Phase Lock Box Failure	Closed
EPS-14	Panel 150 Lying Loose	Closed
EPS-15	J185 Octopus Cable Connector (Reference COMM-1)	Duplicate

SUMMARY OF EPS POTENTIAL INITIATION THEORIES

Page 2

EPS-16	Water Glycol Corrosion of Connector(s)	Delete (General Category)
EPS-17	Glycol Pump Overloaded (Reference ECS-2)	Duplicate
EPS-18	AC Control Box V16-451136 Short	Closed
EPS-19	Evidence of an Arc on Tip of Pin 16 on Panel 20	Closed
EPS-20	Arc of Wire/Cover on J-Box C15-1A52 (Ref. EPS-22)	Duplicate
EPS-21	Wire Short to Junction Box Cover (Ref. EPS-22)	Duplicate
EPS-22	Damaged Wire J-Box C15-1A52 Cover Plate	Closed
EPS-23	Electrical Wires Routed in Front of Heater (Reference P 482 TPS 369 Step 17)	Closed
EPS-24	SPS PUGS Display Unit	Closed
EPS-25	Main Bus B Short to Substructure at S11, Panel 8	Closed
EPS-26	Wiring Arc Near Scientific Equipment Bay LEB Main Bus B 2	Closed Per Fire Board

<u>Total</u>	<u>Open</u>	<u>Closed</u>	<u>Duplicate</u>	<u>Deleted</u>
16	0	16	8	2

POTENTIAL INITIATION THEORIES EVALUATION SHEET

EPS-1

SUBJECT Gas Chromatograph Cable Short

SYSTEM OR COMPONENT \_\_\_\_\_

IGNITION SOURCE AND PROPAGATION \_\_\_\_\_

\_\_\_\_\_  
DUPLICATE - REFERENCE EPS-2

SUPPORTING FACTORS \_\_\_\_\_

NEGATIVE FACTORS \_\_\_\_\_

CONCLUSION \_\_\_\_\_

DATE: 3-23-67

STATUS: \_\_\_\_\_

DUPLICATE

ENCLOSURE 18-55

D-18-336

POTENTIAL INITIATION THEORIES EVALUATION SHEET EPS-2

SUBJECT GAS Chromatograph Connector Short & Cable Short

SYSTEM OR COMPONENT EPS

IGNITION SOURCE AND PROPAGATION Electrical spark or heat, propagation via plastic cover on connector.

SUPPORTING FACTORS Measurement CT0108 starts to vary at 23:30:49.

CB C15A5C116 found open after fire.

NEGATIVE FACTORS \_\_\_\_\_

CONCLUSION Close examination of this connector shows no evidence of arcing

at the connector or associated wiring attributable to an electrical short.

The damaged plug and wiring has been analyzed - the cause was due to external heating.

DATE: 3-22-67 STATUS: Non-initiator - Closed

ENCLOSURE 18-55

POTENTIAL INITIATION THEORIES EVALUATION SHEET

EPS-3

SUBJECT Damaged Wire Harness Under LiOH Door

SYSTEM OR COMPONENT EPS/ECS

IGNITION SOURCE AND PROPAGATION Electrical short on the DC power input  
wiring to the instrumentation on the O<sub>2</sub> panel. Propagation could  
have been along the nearby debris net.

SUPPORTING FACTORS Location in area determined as the probable initiation.  
Possible copper deposits were found on the bottom of the LiOH door.  
Material is being removed for analysis. Sections of the wire harness  
and a portion of the panel has been burnt away eliminating physical  
evidence of potential arcing.

NEGATIVE FACTORS

CONCLUSION This theory is still valid

DATE: 3-24-67 STATUS: Probable Initiator - Closed

POTENTIAL INITIATION THEORY EVALUATION SHEET

EPS-4

SUBJECT Screwdriver damage by technician 17 Jan. '67  
Damaged Wire (1C50A16) on Panel C15-1A52

SYSTEM OR COMPONENT RCS/EPS

IGNITION SOURCE AND PROPAGATION Electrical spark from DC short propagating  
along the wire covering.

SUPPORTING FACTORS On DR 0917, the exposed conductor 1C50A16 was temporarily  
repaired with 7503 Mystic Tape and permanently repaired using heat shrink  
sleeving per standard repair manual.

NEGATIVE FACTORS The harness was diligently examined by a member of the Fire  
Panel and by EPS engineering. There is no evidence of an arc from this  
source. Measurement CH2087 would have indicated zero if the wire had  
shorted. No zero indication was noted.

CONCLUSION Based on the above data and observations, reference TPS CM IV-192,  
it is concluded that this item was not the ignition source.

DATE: 3-21-67

STATUS:

Non-initiator

-

Closed

ENCLOSURE 18-55

D-18-339



NASA - KS  
DISCREPANCY RECORD

Page 1 of 2

5/0012 5/111

PART NAME <b>WIRE</b>		CONTRACT PART NO. <b>V16-440012</b>		SERIAL NO. <b>02</b>	DRAWING NO. <b>V16-000002</b>	
SUPPLIER	SUPPLIER PART NO.	REF. DOC. NO.	TIME/CYCLES IN USE		FAULT	FUNCTION
DISPOSITION	ORIGIN	SYSTEM	WITHHOLDING TAG NO.	HR.	MIN.	SEC.

ITEM NO.	DISCREPANCY
	<b>CONT Dispo.</b>

INITIATOR'S SIGNATURE <i>[Signature]</i>	STAMP NUMBER <b>1114</b>	ORGANIZATION AND LOCATION <b>NSA Lab 34</b>	DATE <b>1/17/67</b>
---	-----------------------------	--	------------------------

ENGINEERING DISPOSITION		29. CONTINUATION SHEET REQUIRED (ASC FORM 4-221)	28. SCRAP TAG NO.	27. REPLACEMENT PART NO.	26. SERIAL NO.
24. NR ACTION REQUIRED <input checked="" type="checkbox"/> YES <input type="checkbox"/> NO	25. NUMBER	<input checked="" type="checkbox"/> YES <input type="checkbox"/> NO			
34. SYSTEM RETEST REQUIRED <input type="checkbox"/> YES <input checked="" type="checkbox"/> NO	30. FAILURE ANALYSIS REQUIRED <input type="checkbox"/> YES <input checked="" type="checkbox"/> NO	31. OTHER SYSTEMS AFFECTED <b>NONE</b>	32. RETEST ACCEPTED DATE: _____ CONTR: _____ NASA: _____		

ITEM NO.	DISPOSITION	ITEM ACCEPTANCE		
		SHOP STAMP	CONTR.	NASA
<b>4.</b>	<b>CONCLUSION REFERENCE STEP 1 &amp; 2 OF DISCREPANCY, THE EXPOSED CONDUCTOR WAS FOUND AT THE SAME HEIGHT. IT WAS CONCLUDED THAT THE WIRE WAS NOTED. THE CONCLUSION IS THAT THE WIRE WAS A GOOD ITEM THE WIRE FUNCTION IS MORE THAN 105000.</b>			
	<b>That was the only wire found in the area. The wire was found in the area of the wire. The wire was found in the area of the wire. The wire was found in the area of the wire.</b>			

FOR FURTHER INFORMATION, CHANGE IN DISPOSITION, ADDITIONAL COMMENTS <b>ORC RECEIVED JAN 26 1967</b>	FINAL ACCEPTANCE	DATE <b>1-19-67</b>	SHOP STAMP 	CONTR. 	NASA 
--	------------------	------------------------	----------------	------------	----------

ASC FORM 4-21 (5/65)

RECORD COPY



POTENTIAL INITIATION THEORIES EVALUATION SHEET

EPS-5

SUBJECT Teleflex Cable Shorting Resistor R7  
at C15A7TB61-7

SYSTEM OR COMPONENT \_\_\_\_\_

IGNITION SOURCE AND PROPAGATION \_\_\_\_\_  
\_\_\_\_\_  
\_\_\_\_\_

\_\_\_\_\_  
DUPLICATE - REFERENCE COMM-2  
\_\_\_\_\_

SUPPORTING FACTORS \_\_\_\_\_  
\_\_\_\_\_  
\_\_\_\_\_  
\_\_\_\_\_  
\_\_\_\_\_

NEGATIVE FACTORS \_\_\_\_\_  
\_\_\_\_\_  
\_\_\_\_\_  
\_\_\_\_\_  
\_\_\_\_\_

CONCLUSION \_\_\_\_\_  
\_\_\_\_\_  
\_\_\_\_\_  
\_\_\_\_\_

DATE: 3-23-67

STATUS: DUPLICATE

POTENTIAL INITIATION THEORIES EVALUATION SHEET

EPS-6

SUBJECT Electrical Short Due to Cold Flow Characteristics  
of Teflon Wire

SYSTEM OR COMPONENT EPS, SPS, RCS, T/C, G&N. SEQ, C&W,  
& Scientific Experiments

IGNITION SOURCE AND PROPAGATION Electrical spark, propagation via Velcro,  
debris trap.

SUPPORTING FACTORS None

NEGATIVE FACTORS Detailed examination of harnesses in suspect areas revealed  
no evidence of shorting or arcing due to the cold flow characteristics  
of teflon. Reference TPS CM-IV-192.

CONCLUSION This item is a general statement and cannot be tied to a specific  
location or initiation theory. It will be covered by a general discussion  
in the Panel 18 report. Transferred to General Discussion.

DATE: 3-24-67 STATUS: Closed as a specific item.

POTENTIAL INITIATION THEORIES EVALUATION SHEET

EPS-7

SUBJECT Q-Ball Wiring Short

SYSTEM OR COMPONENT SEQ

IGNITION SOURCE AND PROPAGATION Electrical spark, propagation via S/C harness.

SUPPORTING FACTORS None

NEGATIVE FACTORS Pin-to-pin and pin-to-ground resistance checks revealed  
no anomalies in these circuits. Reference TPS SC012-088 which performed  
resistance checks on Q-Ball wiring.

CONCLUSION Wiring was extended to CM pressure shell. The continuity  
checks and physical evaluation of connector at Q-Ball revealed that it  
was mated with the stowage connector.

DATE: 3-22-67 STATUS: Non-initiator - Closed

POTENTIAL INITIATION THEORIES EVALUATION SHEET

EPS-8

SUBJECT CB64 on Panel 25 (SCS GRP 2 MNB)  
Rubbing against wire harness

SYSTEM OR COMPONENT SCS

IGNITION SOURCE AND PROPAGATION Electrical spark

SUPPORTING FACTORS Indications of interference between CB64 & wire harness

behind Panel 25. Indentation in Teflon insulation on wire harness

matches with "white" deposit on terminal of CB 64.

NEGATIVE FACTORS No visual indication of any arc was noted.

CONCLUSION Close this item. Detailed examination of panel revealed no  
indications of shorts or arcs.

DATE: 3-22-67 STATUS: Non-initiator - Closed

POTENTIAL INITIATION THEORIES EVALUATION SHEET

EPS-9

SUBJECT Tapes on Entry Batteries  
(White Room Tape)

SYSTEM OR COMPONENT EPS

IGNITION SOURCE AND PROPAGATION Glycol residue on tape covering battery  
terminals provides a conductive path which after a prolonged period gets  
hot and ignites.

SUPPORTING FACTORS Tape on battery terminals - flammability of material.

NEGATIVE FACTORS Location removed from Fire Panel indicated most probable  
ignition area. No mechanism to provide conductive path.

CONCLUSION Inspection shows no adjacent ignition source which would  
be a propagation path.

DATE: 3-23-67 STATUS: Non-initiator - Closed

ENCLOSURE 18-55

D-18-346

POTENTIAL INITIATION THEORIES EVALUATION SHEET EPS-10

SUBJECT Pyro Batteries Vented to Cabin

SYSTEM OR COMPONENT EPS

IGNITION SOURCE AND PROPAGATION Outgassing of Batteries

SUPPORTING FACTORS None

NEGATIVE FACTORS Venting occurs only during excessive charging or discharging.

Subsequent tests verify the pyro batteries had not been subject to any  
condition which could have resulted in venting. No indication of fire  
initiation in this area.

CONCLUSION Close this item based upon lack of supporting factors and

result of lab tests. Physical inspection of the batteries showed no  
external evidence of KOH which probably indicates no venting.

DATE: 3-22-67 STATUS: Non-initiator - Closed

POTENTIAL INITIATION THEORIES EVALUATION SHEET

EPS-11

SUBJECT Cabin Fan Failure

SYSTEM OR COMPONENT \_\_\_\_\_

IGNITION SOURCE AND PROPAGATION \_\_\_\_\_

\_\_\_\_\_  
DUPLICATE - REFERENCE ECS-4

SUPPORTING FACTORS \_\_\_\_\_

NEGATIVE FACTORS \_\_\_\_\_

CONCLUSION \_\_\_\_\_

DATE: 3-23-67

STATUS: DUPLICATE

ENCLOSURE 18-55

D-18-348

POTENTIAL INITIATION THEORIES EVALUATION SHEET

EPS-12

SUBJECT Suit Compressor Overloaded

SYSTEM OR COMPONENT \_\_\_\_\_

IGNITION SOURCE AND PROPAGATION \_\_\_\_\_  
\_\_\_\_\_  
\_\_\_\_\_

DUPLICATE - REFERENCE ECS-3

SUPPORTING FACTORS \_\_\_\_\_  
\_\_\_\_\_  
\_\_\_\_\_  
\_\_\_\_\_

NEGATIVE FACTORS \_\_\_\_\_  
\_\_\_\_\_  
\_\_\_\_\_  
\_\_\_\_\_

CONCLUSION \_\_\_\_\_  
\_\_\_\_\_  
\_\_\_\_\_  
\_\_\_\_\_

DATE: 3-23-67

STATUS: \_\_\_\_\_

DUPLICATE

ENCLOSURE 18-55

D-18-349



POTENTIAL INITIATION THEORIES EVALUATION SHEET

EPS-13

SUBJECT Inverter Phase Lock Box (Panel 208) Failure

SYSTEM OR COMPONENT EPS

IGNITION SOURCE AND PROPAGATION Heat

SUPPORTING FACTORS None

NEGATIVE FACTORS The three circuit breakers CB 1, 2, and 3 on Panel 209 which supplied all power to the phase lock box (Panel 208) was open per OCP and found open subsequent to the fire.

CONCLUSION Close this item. The phase synch box was examined and shows no indication of overheating or other evidence of ignition source. The phase lock box was not energized from switch position information.

DATE: 3-22-67 STATUS: Non-initiator - Closed

ENCLOSURE 18-55

D-18-350

POTENTIAL INITIATION THEORIES EVALUATION SHEET EPS-14

SUBJECT Panel 150 Lying Loose

SYSTEM OR COMPONENT EPS

IGNITION SOURCE AND PROPAGATION Electrical spark or heat.

SUPPORTING FACTORS Panel 150 has circuit breakers which connect directly to

the 3 entry batteries and 2 pyro batteries. This panel was not installed

in place and was "resting" on a harness.

NEGATIVE FACTORS No evidence of arcing or fire initiation in this area.

CONCLUSION Close this item. Extensive examination of panel 150 revealed

no evidence of arcing or shorting. Electrical checks substantiate

Nominal resistance and functional circuit breakers.

DATE: 3-22-67 STATUS: Non-initiator - Closed

POTENTIAL INITIATION THEORIES EVALUATION SHEET

EPS-15

SUBJECT J185 Octopus Cable Connector

SYSTEM OR COMPONENT \_\_\_\_\_

IGNITION SOURCE AND PROPAGATION \_\_\_\_\_  
\_\_\_\_\_  
\_\_\_\_\_

DUPLICATE - REFERENCE COMM-1

SUPPORTING FACTORS \_\_\_\_\_  
\_\_\_\_\_  
\_\_\_\_\_  
\_\_\_\_\_

NEGATIVE FACTORS \_\_\_\_\_  
\_\_\_\_\_  
\_\_\_\_\_  
\_\_\_\_\_

CONCLUSION \_\_\_\_\_  
\_\_\_\_\_  
\_\_\_\_\_  
\_\_\_\_\_

DATE: 3-23-67 STATUS: DUPLICATE

ENCLOSURE 18-55

D-18-352

POTENTIAL INITIATION THEORIES EVALUATION SHEET

EPS-16

SUBJECT Water Glycol Corrosion of Connector(s)

SYSTEM OR COMPONENT \_\_\_\_\_

IGNITION SOURCE AND PROPAGATION \_\_\_\_\_  
\_\_\_\_\_  
\_\_\_\_\_  
\_\_\_\_\_

SUPPORTING FACTORS \_\_\_\_\_  
\_\_\_\_\_  
\_\_\_\_\_  
\_\_\_\_\_

NEGATIVE FACTORS \_\_\_\_\_  
\_\_\_\_\_  
\_\_\_\_\_  
\_\_\_\_\_

CONCLUSION This item is very general. A discussion will be included in  
the Panel 18 Final Report.  
\_\_\_\_\_  
\_\_\_\_\_

DATE: 3-24-67 STATUS: Closed as a specific item

POTENTIAL INITIATION THEORIES EVALUATION SHEET

EPS-17

SUBJECT Glycol Pump Overloaded

SYSTEM OR COMPONENT \_\_\_\_\_

IGNITION SOURCE AND PROPAGATION \_\_\_\_\_

\_\_\_\_\_  
DUPLICATE - REFERENCE ECS-2

SUPPORTING FACTORS \_\_\_\_\_

NEGATIVE FACTORS \_\_\_\_\_

CONCLUSION \_\_\_\_\_

DATE: 3-23-67

STATUS: \_\_\_\_\_

DUPLICATE

ENCLOSURE 18-55

D-18-354

POTENTIAL IGNITION SOURCE EVALUATION SHEET

EPS-18

SUBJECT AC Control Box V16-451136 Short

SYSTEM OR COMPONENT EPS

IGNITION SOURCE AND PROPAGATION Electrical short and/or heat propagating  
via an unknown mechanism.

SUPPORTING FACTORS Burned conformal coating on terminals 13 and 23 of  
motor switch S5.

NEGATIVE FACTORS Visual examination showed no evidence that the teflon on  
the wire was damaged. Electrical tests, reference TPS CM CA-056  
indicated that the circuit was still intact.

CONCLUSION Based on the above tests and visual inspection, it is concluded  
that this item was not the ignition source. A member of the Fire Panel  
concur.

DATE: 3-21-67 STATUS: Non-initiator - Closed

POTENTIAL INITIATION THEORIES EVALUATION SHEET EPS-19

SUBJECT Evidence of an ARC on Tip to Pin 16 on Panel 20

SYSTEM OR COMPONENT T/C

IGNITION SOURCE AND PROPAGATION Electrical spark

SUPPORTING FACTORS Visual inspection indicates that the tip of Pin 16

(VHF/AM +28 VDC) has arced.

NEGATIVE FACTORS Arc is only on tip radius of pin. Tip radius is not rubbed

when connector is mated. There is no evidence of overheating or arcing

of pin or mating connector. The small mark on the tip radius of the pin

most probably occurred during panel checkout prior to installation and

was not rubbed off when the connector was mated.  
CONCLUSION

There is no evidence that this item was an initiator or the fire.

DATE: 3-22-67 STATUS: Non-initiator - Closed

POTENTIAL INITIATION THEORIES EVALUATION SHEET EPS-20

SUBJECT ARC of Wire/Cover on J-BOX C15-1A52

SYSTEM OR COMPONENT \_\_\_\_\_

IGNITION SOURCE AND PROPAGATION \_\_\_\_\_

\_\_\_\_\_

DUPLICATE - REFERENCE EPS-22

\_\_\_\_\_

SUPPORTING FACTORS \_\_\_\_\_

\_\_\_\_\_

\_\_\_\_\_

\_\_\_\_\_

NEGATIVE FACTORS \_\_\_\_\_

\_\_\_\_\_

\_\_\_\_\_

\_\_\_\_\_

CONCLUSION \_\_\_\_\_

\_\_\_\_\_

\_\_\_\_\_

\_\_\_\_\_

DATE: 3-23-67 STATUS: DUPLICATE



POTENTIAL INITIATION THEORIES EVALUATION SHEET

EPS-21

SUBJECT Wire Short to Junction Box Cover

SYSTEM OR COMPONENT \_\_\_\_\_

IGNITION SOURCE AND PROPAGATION \_\_\_\_\_

\_\_\_\_\_  
DUPLICATE - REFERENCE EPS-22  
\_\_\_\_\_

SUPPORTING FACTORS \_\_\_\_\_

NEGATIVE FACTORS \_\_\_\_\_

CONCLUSION \_\_\_\_\_

DATE: 3-23-67

STATUS: \_\_\_\_\_

DUPLICATE

POTENTIAL INITIATION THEORIES EVALUATION SHEET

EPS-22

SUBJECT Damaged Wire J-Box C15-1A52 Cover Plate

SYSTEM OR COMPONENT EPS/RCS (+Yaw Normal Power MNA)

IGNITION SOURCE AND PROPAGATION Arcing of the DC power to the  
cover plate.

SUPPORTING FACTORS High energy source (250 amp power supply through a  
20 amp circuit breaker and #16 wire). Evidence of arcing or welding on  
the panel cover plate and on the adjacent power wire. Propagation could  
have been by the wire coating glycol residue, and/or nearby debris net,  
Velcro, etc. ignited either locally or at a distance by flying sparks.  
This area matches the Fire Panel's theory about where the fire started.

NEGATIVE FACTORS No evidence of a momentary overload on Main Bus A.

CONCLUSION This theory is not prime suspect.

DATE: 3-24-67

STATUS: Non-initiator - Closed

POTENTIAL INITIATION THEORIES EVALUATION SHEET

EPS-23

SUBJECT Electrical Wires Routed in Front of Heater  
(Reference P482 TPS 369 Step 17)

SYSTEM OR COMPONENT EPS/ECS

IGNITION SOURCE AND PROPAGATION Overheated wiring in vicinity of urine

dump heater.

SUPPORTING FACTORS None.

NEGATIVE FACTORS Heaters not on per OCP. C/B's verify this configuration.

Heater located in aft compartment. No evidence of fire having originated  
in this area.

CONCLUSION Since no power was applied to this circuit and physical evidence  
indicated fire did not originate in aft compartment, close this item.

DATE: 3-28-67 STATUS: Non-initiator - Closed

ENCLOSURE 18-55

D-18-360

POTENTIAL INITIATION THEORIES EVALUATION SHEET

EPS-24

SUBJECT SPS PUGS Display Unit

SYSTEM OR COMPONENT SPS

IGNITION SOURCE AND PROPAGATION 28 VDC and 115 V, 400 Cycle, was  
present within the PUGS Display Unit at the time of accident. All PUGS  
circuit breakers were closed.

SUPPORTING FACTORS None

NEGATIVE FACTORS TPS S/C012-CM-CA-092 was performed satisfactorily  
which verified the functional integrity of the PUGS Display Panel Assembly.  
All data obtained was within specified accuracy of applicable process spec.  
MA0210-0171, Sect. 61.

CONCLUSION The only visible damage to the PUGS Display Panel Assembly  
is a cracked glass on the face of unbalance meter. This unit should  
have in no way contributed to the S/C 012 accident.

DATE: 3-24-67 STATUS: Non-initiator - Closed

POTENTIAL INITIATION THEORIES EVALUATION SHEET EPS-25

SUBJECT Main Bus B Short to Substructure at S11, Panel 8

SYSTEM OR COMPONENT Main Display Console

IGNITION SOURCE AND PROPAGATION Potential short circuit or arc through area  
of conformal coating on one terminal of S11 that contacted substructure behind  
Panel #8.

SUPPORTING FACTORS Continuity check through damaged area of conformal coating  
on S11 terminal shows potential short circuit to substructure. Microscopic examina-  
tion of substructure disclosed minute area of sparking, or arcing, in area of  
terminal contact.

NEGATIVE FACTORS Area of sparking to substructure is minute. The arc pits can  
only be observed under at least 10 power magnification. There is no evident damage  
due to overheating to the conformal coating on the switch terminal.

CONCLUSION An intermittant short to the substructure existed from S11 through the  
conformal coating. However, the size of the observed arc pits and the lack of  
heat caused decomposition of the conformal coating indicate that the heating was  
insufficient to have been the ignition source.

DATE: 3-24-67 STATUS: Non-initiator - Closed

POTENTIAL INITIATION THEORIES EVALUATION SHEET

EPS-26

SUBJECT Wiring Arc near Scientific Equipment Bay 2

LEB Main Bus B

SYSTEM OR COMPONENT EPS

IGNITION SOURCE AND PROPAGATION Electrical arc igniting battery tape.

SUPPORTING FACTORS Evidence of arcing. Battery tape was burned. A

short on Main Bus B could account for the AC Bus #2 voltage

transient.

NEGATIVE FACTORS Inspection by the Fire Board resulted in the conclusion

that the absence of a propagation path negates this theory.

CONCLUSION This theory should be closed based on the results of the

Fire Board inspection.

DATE 3-27-67 STATUS Non-initiator - Closed

POTENTIAL INITIATION THEORIES EVALUATION SHEET

SUBJECT STATIC CHARGE BUILDUP IN SUITS

SYSTEM OR COMPONENT PRESSURE GARMENT ASSEMBLY

IGNITION SOURCE AND PROPAGATION POSSIBILITY OF STATIC CHARGE BUILDUP  
AND DISCHARGE BETWEEN SUITED ASTRONAUT AND S/C.

SUPPORTING FACTORS SUIT AND COUCH PAD MATERIAL WAS BURNED.

NEGATIVE FACTORS TPS S/C 014 CM 038 WAS PERFORMED WITH A SUITED PERSON,  
VENTILATED WITH DRY AIR. READINGS OF CAPACITANCE AND VOLTAGE BETWEEN  
SUBJECT AND S/C WERE BELOW THE ENERGY REQUIREMENTS TO IGNITE ANY SOLID  
MATERIALS FOUND IN S/C.

CONCLUSION A SUITED PERSON CANNOT GENERATE SUFFICIENT ELECTROSTATIC  
ENERGY TO IGNITE ANY SOLID MATERIALS FOUND IN S/C

DATE: 3/27/67 STATUS: Non-initiator - Closed

BRIEF SUMMARY OF SIGNIFICANT

SPECIAL TEST RESULTS

1. Effect of Water-Glycol on Gas Chromatograph Cable and Connector

Tests conducted to determine the reaction of the cable and its contribution to the accident if water-glycol had contacted the gas chromatograph connector. Tests indicated that no voltages appeared at the two shielded signal leads until all connector pins were completely immersed. At that point a 400 cps, approximately 4.5 volt, signal was noted. Ignition did not occur; however, what appeared to be localized boiling was noted in the area of two 115-volt connector pins which were adjacent to each other on the connector.

2. Effects of Water-Glycol on Spacecraft Connectors

During the checkout phase of Spacecraft 012 operations, water-glycol leaks and spillages were encountered. Some of the spacecraft harnesses were wetted and subsequently cleaned with water and alcohol, and dried with nitrogen. Test conducted to determine if the cleaning procedure was adequate and to determine the effects of exposure of electrical connectors to water-glycol. Test incomplete at this time as 20-day cycle started on March 14, 1967. Tests being conducted at KSC.



3. Determine  $\Delta P$  vs CDU Gimbal Angles

A test was conducted on Spacecraft 008 at MSC to obtain data on CDU gimbal angle changes at various cabin differential pressures. This data was then used for correlation with data available from Spacecraft 012. All of the data are contained in the Panel 10 Final Report.

4. Corner Ignition Test

A test was conducted at MSC in a 14.7 psia, 100% oxygen environment to determine whether ignition of a nylon chafing strip at the left-hand portion of the lower equipment bay will ignite the remaining flammable materials in the immediate vicinity. Test disclosed that all debris netting and Velcro on flight qual recorder burned completely as a result of the nylon ignition.

5. Boilerplate Mock-up Fire Tests

Boilerplate A at MSC was mocked-up as close as possible to the Spacecraft 012 internal cabin configuration with respect to flammable materials. A fire was then started to try to reproduce the Spacecraft 012 accident. Five tests have been conducted to date, under various pressure and oxygen environments. The test results are covered in detail in the Panel 8 Final Report.

#### 6. Wet Wire Fire Ignition Test

A test was conducted at MSC to determine whether water-glycol will ultimately lead to shorting and ignition when dripped on wires with deliberate flaws. The test indicated that a conductor carrying 3 amp 28 volts DC did ignite approximately 8 hours after exposure to a water-glycol drip.

#### 7. Summary of Spacecraft 008 DC and AC Electrical Tests

The results from each of the electrical tests conducted on Spacecraft 008 are summarized in the following paragraphs. The many tests and test conditions were primarily compared to the PCM data obtained at the time of the AC electrical transient on Spacecraft 012, to establish what condition or set of conditions would duplicate that data.

(a) Effect of Rapid Switching of Non-Essential Bus from DC bus A to DC bus B

This test condition did not produce data similar to that on Spacecraft 012.

(b) Effect of Inverter Switching to Supply AC Buses

This test condition did not produce data similar to that of Spacecraft 012. The over-shoot amplitudes on the AC bus voltages were too low and too rapid.

(c) Effect of Load Switching on the AC Buses

This test condition did not produce data similar to that of Spacecraft 012. The drop in voltage on the AC bus due to switching any of the large electrical loads was

regulated by the inverter to maintain the DC bus voltage above the minimum required to cause a dropout of the VHF/FM transmitter and C-band beacon.

(d) Effects of Shorts of Various Durations and Levels on AC bus 2 Circuits

These tests did not produce data similar to that of Spacecraft 012. The prime difference was the lack of proper amplitude for the three AC bus 2 voltages. However, dropout effects of the VHF/FM transmitter and C-band beacon, and the recovery time for the AC voltages were similar to that of Spacecraft 012.

(e) Effects of Interrupting DC Power to the Control Relays which Control Switching of AC Power to the VHF/FM Transmitter and C-band Beacon

These tests did not produce data similar to that of Spacecraft 012. The dropout of the transmitter and beacon could be reproduced; however, the effect on the AC voltages was not present.

(f) Effects of DC Shorts of Various Durations and Levels on the DC bus

DC shorts of a 5 to 20 milliseconds duration for current values of about 80 amps or greater are required to drop the voltage on the DC bus sufficiently to cause the inverter to lose regulation. These tests indicated that shorts of several milliseconds duration and of sufficient current drain can closely reproduce the Spacecraft 012 data indications at the time of the AC bus 2 transient.

(g) Effects of Momentary Interruption of DC Power to the Inverter

A DC interruption of 2.5 to 20 milliseconds duration will reproduce the Spacecraft 012 data indications at the time of the AC bus 2 transient.

(h) Determine Arcing Damage to Wires of Various Sizes Used Within the Spacecraft, With Current Limited to Values Commensurate with Circuit Characteristics of the Spacecraft

The wire damage due to arcing was found to be primarily a function of the resistance at the shorting point. A relatively high current passing through a short of very low resistance would cause little or no damage as compared to a relatively low current passing through a short of several ohms resistance.

(i) Effects of Shorting Power Leads in the Octopus Cable to the MDAS Recorder

A momentary short on the octopus cable power wires would not cause a drop of voltage on the DC bus sufficiently low enough to cause the inverter to lose regulation. Also, the effect of a momentary short appeared on the biomed monitoring channels of the MDAS recorder as transients. A short of greater than 8 milliseconds duration would cause the time reference of the MDAS to lose time.

8. TV Simulation Using Spacecraft 008

Several individuals witnessed the Spacecraft 012 accident on television monitors. A test was accomplished utilizing

Spacecraft 008 to substantiate the visual resolution that one could expect over a television monitor system. No additional conclusions or observations resulted from the conduct of this test.

9. Cobra Cable Spark Ignition Tests

The minimum ignition energies of several solvents used in the Spacecraft and the problems experienced with the communications system indicated that the connect or disconnect of a cobra cable could be suspect as a spark or ignition in a simulated Spacecraft 012 environment. Separation of the cobra cable did not produce any visible sparks or ignition.

10. Suit Electrostatic Discharge Tests

Tests were conducted to determine the energy that can be transferred from a suited person when the suit is electrostatically charged. Tests conducted in Spacecraft 014 indicate that insufficient energy is generated for ignition to occur.

11. Mock-up 2 Mobility Evaluation Test

This test was conducted to determine the capability of a crew to see certain areas of the Spacecraft and to perform certain actions with respect to time.

12. Gas Chromatograph Cable and Connector Tests

Special tests disclosed that an output from the gas chromatograph connector can be produced by:

(a) Physical movement or disturbance of the wiring and/or the connector

(b) Application of external heat to the wiring and/or the connector.

13. Voltage Regulation Tests at Launch Complex 34

These tests indicated that a short circuit in the range of 5 to 25 milliseconds, drawing approximately 75 amps, caused an immediate drop in DC bus voltage of 13 to 15 volts.

14. Gas Chromatograph Cable Arcing Test

A test was conducted using Spacecraft 008 to determine whether arcing would occur if the gas chromatograph connector was dropped onto a metal surface. No arcing took place.

15. Test to Reproduce Copper Flow Found on Gas Chromatograph Cable

Tests were conducted to reproduce a copper flow condition found on the AC wires of the gas chromatograph cable. All attempts to simulate the condition by either short circuits or by application of external heat did not result in a similar appearance of the wires.

16. Pyrotechnic Battery Hydrogen Outgassing Tests

Tests have been conducted on pyrotechnic batteries to determine the outgassing characteristics at ambient and elevated temperatures. Based on these tests, it was concluded that the battery relief valves did not relieve and admit hydrogen to the Command Module.

17. Flammability Propagation Rates of Debris Netting

Tests were conducted at KSC to determine the flammability propagation characteristics of the debris netting of that type located in the Command Module floor at the ECU. Tests conducted at an ambient pressure, 100% oxygen atmosphere, produced a burning rate of approximately 2 inches per second, burning in a horizontal direction. Refer to the Panel 8 Final Report for more information on other materials' flammability test results.

18. Water-Glycol Flammability Tests

A number of water-glycol flammability tests have been conducted at KSC and at MSC, and are still continuing at this time. Some of the tests indicate that the inhibitor agent in the water-glycol coolant fluid does provide a flame propagation path along electrical harnesses exposed to leakage and spillage of water-glycol.

## List of References

<u>Reference</u>	<u>Description</u>
18-1	"Screening Committee Final Report", dated March 24, 1967
18-2	"Structural Assessment Report", dated February 8, 1967, prepared by NASA-MSC, Mr. P. C. Glynn
18-3	"Explanation and Discussion of ECS Water/Glycol Circuit Prior to and After the Fire Report", dated February 6, 1967, prepared by NASA-MSC, Mr. F. H. Samonski
18-4	"Spillage of Ethylene Glycol/Water (RS89-a) as a Possible Cause of Fire in SC204", dated February 20, 1967, prepared by NASA-MSC, Dr. W. R. Downs
18-5	"ECS Oxygen System Description and Interim Data Evaluation", dated February 9, 1967, prepared by NASA-MSC, Mr. F. H. Samonski
18-6	"Communications Analysis Report", dated February 15, 1967, prepared by NASA-MSC, Mr. O. A. Beers
18-7	"Mock-up 2 Mobility Evaluation Test Results", dated March 9, 1967, prepared by NAA-Downey, Mr. J. W. Montgomery
18-8	"Analysis of Tape Recorder Transmissions From Apollo Spacecraft on January 27, 1967", prepared by Bell Telephone Laboratories, Incorporated
18-9	"Analysis of Tape Recorded Transmission From Apollo Spacecraft 012", dated March 23, 1967, prepared by NASA-MSC, Instrumentation and Electronic Systems Division



This page left blank intentionally.