



**GLENN  
PROCEDURAL  
REQUIREMENTS**

**Directive: GLPR 7120.5.10B**  
Effective Date: **06/04/2025**  
Expiration Date: **06/04/2030**

**COMPLIANCE IS MANDATORY**

---

**THIS DOCUMENT IS UNCONTROLLED WHEN PRINTED.**

Validate prior to use at <https://nasa.sharepoint.com/sites/BMSLibrary/>

---

**Responsible Office: Code MB - Program/Project Integration Office**  
**Subject: GRC Space Flight Project Management**  
**Requirements and Best Practices w/Change 1 (05/01/2026)**

---

**TABLE OF CONTENTS**

**Preface**

- P.1 Purpose
- P.2 Applicability
- P.3 Authority
- P.4 Applicable Documents and Forms
- P.5 Measurement/Verification
- P.6 Cancellation

**Chapter 1: Introduction**

**Chapter 2: Project Management Requirements**

- 2.1 Purpose
- 2.2 Governance
- 2.3 Project Classification
- 2.4 Delegation of Management Authority
- 2.5 Required Responsibilities
- 2.6 Tailoring
- 2.7 Technical Authority and Formal Dissents

**Chapter 3: Best Practices**

- 3.1 Introduction and Summary
- 3.2 Project/Task Initiation
- 3.3 Establish Project/Task Team
- 3.4 Project/Task Planning
- 3.5 Define Work Breakdown Structure
- 3.6 Develop Acquisition (Make/Buy) Strategy

- 3.7 Define and Estimate the Work
- 3.8 Develop Budget and Schedule
- 3.9 Develop Agreements
- 3.10 Develop Formulation Agreement, Project Plan, and Task Plan
- 3.11 Establish Technical, Budget, and Schedule Baselines
- 3.12 Develop Independent Cost and Schedule Assessments
- 3.13 Perform Annual Planning, Programming, Budgeting, and Execution Process
- 3.14 Estimate Center Program Direct Assessments
- 3.15 Develop Resource Phasing Plans
- 3.16 Acquire Performance-Based Contractor Support
- 3.17 Acquire External Contractor Products and Services
- 3.18 Perform Continuous Risk Management and Risk-Informed Decision Making
- 3.19 Perform Earned Value Management (EVM)
- 3.20 Perform Budget and Schedule Variance Analysis
- 3.21 Operate Project Control Board
- 3.22 Perform Technical Management
- 3.23 Perform Periodic Reporting
- 3.24 Stoplight Variance Criteria
- 3.25 Perform Milestone Reviews
- 3.26 Process Deviations and Waivers
- 3.27 Project/Task Closeout
- 3.28 Develop and Publish Lessons Learned

## **LIST OF TABLES**

- Table 1-1. Document Content Applicability Guide for GRC Projects and Tasks
- Table 2-1. GRC Space Flight Systems Project and Task Classification Guidance
- Table 2-2. GRC Governance/Approval Authority Guidance
- Table 2-3. GRC Periodic Reporting Guidance
- Table 3-1. Project/Task Core Team Role Guidance
- Table 3-2. Project/Task Team Organization Design Principles
- Table 3-3. WBS Structure Template
- Table 3-4. Typical Control Plans Described in a Project Plan
- Table 3-5. Typical Content of Task Plan

## **LIST OF FIGURES**

- Figure P-1. Standard NASA Programmatic Hierarchy (NASA Headquarters (HQ))
- Figure 2-1. Delegation of Management Authority for Space Flight Systems Projects
- Figure 3-1. Standard Project/Task Organization Template for Space Flight Projects (Contracting Officer (CO), Contracting Officer's Representative (COR), Lead Systems Engineer (LSE), Configuration Management (CM), Information Technology (IT), International Traffic in Arms Regulations (ITAR), Discipline Lead Engineer (DLE), Control Account Manager (CAM))
- Figure 3-2. Project/Task Initial Planning Process
- Figure 3-3. GRC Lessons Learned Resources

Figure 3-4. Standard Level 2 WBS Elements for Space Flight Projects (“NASA Space Flight Program and Project Management Handbook,” Figure 5-24)  
Figure 3-5. Process to Define and Estimate the Project/Task Work  
Figure 3-6. Typical Aerospace System Product Breakdown Definition  
Figure 3-7. Schedule and Price the Work Procedure  
Figure 3-8. Thresholds for Reportable Budget Variance, and Example as Reported  
Figure 3-9. Example of Updated Schedule Status Compared with Baseline  
Figure 3-10. Example of Acumen Fuse Schedule Variance Report  
Figure 3-11. Example of Acumen Fuse Schedule Variance Management Report  
Figure 3-12. PCB Formulation Flow  
Figure 3-13. PCB Operating Flow  
Figure 3-14. Stoplight Variance Criteria for Project/Task Status Reporting

Appendix A: Definitions

Appendix B: Acronyms

Appendix C: Project Compliance Matrix and Instructions

Appendix D: Project/Task Scope Summary Template Example

Appendix E: Project Formulation Agreement Template and Instructions

Appendix F: Project Plan Template and Instructions

Appendix G: External Support Agreement Template

Appendix H: Project Milestone Products Maturity Matrix

Appendix I: Project Control Board Charter Template

Change History Log

Distribution: BMS Library

# PREFACE

## P.1 PURPOSE

- a. The purpose of this document is to set forth Space Flight Systems (SFS) Project and Task requirements established by the NASA Glenn Research Center (GRC) for Projects governed under NASA Procedural Requirements (NPR) 7120.5, NASA Space Flight Program and Project Management Requirements. It specifically responds to NPR 7120.5 requirement 1.1.2, “NASA Centers, Mission Directorates, and other organizations that have programs or projects *shall* develop appropriate documentation to implement the requirements of this... [NPR].”
- b. A key objective of this document is to emphasize the use of tailoring at the beginning of the Project or Task to minimize the risk of over management, especially on smaller efforts performed for other lead centers and funding partners. Per NPR 7120.5, all Projects are required to tailor the standard space flight project management requirements and processes to improve Project/Task efficiency. Section 2.6 is provided to aid in this process.

## P.2 APPLICABILITY

- a. The requirements of this Glenn Procedural Requirement (GLPR) apply to those Projects and Tasks that have been designated NPR 7120.5-compliant by an assigning NASA Mission Directorate and/or Program Office, or by GRC Center Management or SFS Directorate Management. This includes when the flight system effort is contracted (i.e., “buy” acquisition approach), when the flight system is a shared responsibility of GRC and a partner, and when Projects are implemented in an “in-house” (i.e., “make” approach) mode.
- b. American National Standards Institute (ANSI)/PMI 99-001-2017, “A Guide to the Project Management Body of Knowledge—PMBOK Guide,” 7th Edition, defines “Project” as follows: “A Project is a temporary endeavor undertaken to create a unique product, service, or result. The temporary nature of Projects indicates a definite beginning and end. The end is reached when the Project’s objectives have been achieved or when the Project is terminated because its objectives will not or cannot be met, or when the need for the Project no longer exists. Temporary does not necessarily mean short in duration... Every Project creates a unique product, service, or result.”
- c. For the purposes of applying the requirements and best practices in this document to work at GRC, the following definitions are used herein:
  - (1) **Project:** A funded effort that has been assigned to GRC to *lead*. These are typically Level III Projects as per the Standard NASA Programmatic Hierarchy shown in Figure P [*See next page*].
  - (2) **Task:** A funded effort that is performed in support of another NASA Center or other organization, such as a partnering federal agency or a reimbursing industry partner. These will be referred to as Tasks herein and are typically organized at the Level IV tier (or below) in Figure P.
  - (3) **Mission Directorate Support (MDS):** Work within SFS portfolio assigned by a mission directorate to support directorate administrative tasks. SFS office chiefs may assign to low-level full-time equivalent (FTE) CS/low dollar value tasks where minimal documentation and internal reporting to the program is required.

- (4) **Formulation:** The identification of how the project supports the Agency’s strategic needs, goals; and objectives, the assessment of feasibility, technology, and concepts; risk assessment; team building; development of operations concepts and acquisition strategies; establishment of high-level requirements and success criteria; the preparation of plans, budgets, and schedules essential to the success of a project; and the establishment of control systems to ensure performance to those plans and alignment with current Agency strategies. Per NPR 7120.5, Figure 2-5, Formulation occurs during Project life cycle Phase A—Concept and Technology Development, and Phase B—Preliminary Design and Technology Completion.
- (5) **Implementation:** The execution of approved plans for the development and operation of the project and for the use of control systems to ensure performance to approved plans and continued alignment with the Agency’s goals, strategic needs and objectives. Per NPR 7120.5, Figure 2-5, Implementation typically occurs during project life cycle Phase C—Final Design and Fabrication, Phase D—System Assembly, Integration and Test, Launch and Checkout, Phase E—Operations and Sustainment, and Phase F—Closeout.

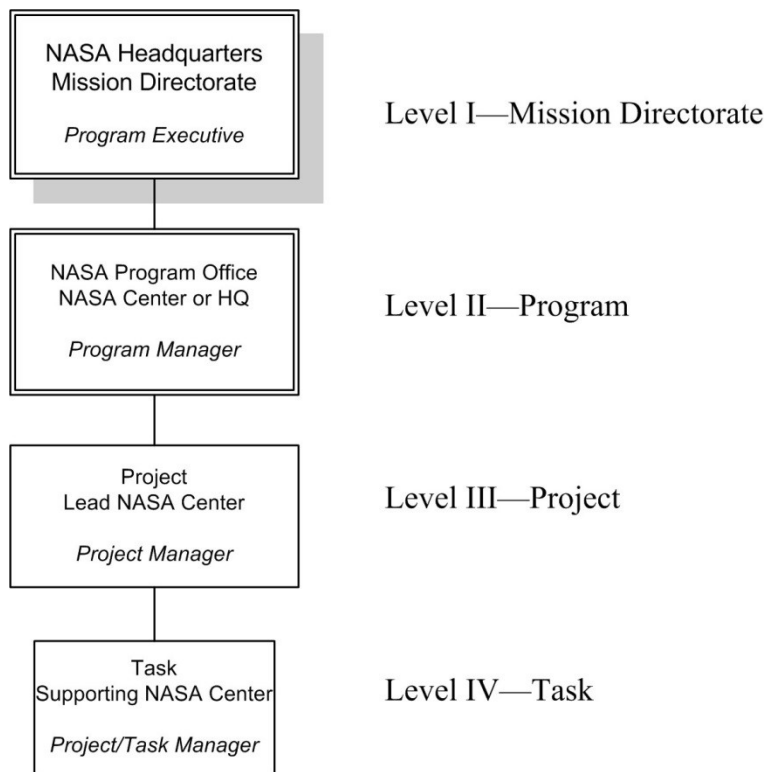

**Figure P-1. Standard NASA Programmatic Hierarchy (NASA Headquarters (HQ))**

- d. This document applies to Space flight projects performed for NASA and non-NASA sponsors governed under NPR 7120.5, including:
- (1) Flight Systems and Ground Support (FS&GS) Programs/Projects/Tasks.
  - (2) Advanced Technology Development (ATD) Programs/Projects directly funded by FS&GS Programs/Projects, or ATD Programs/Projects with outcomes directly tied to space flight mission success and schedule.

- (3) Critical technical facilities specifically developed or significantly modified for space flight systems and ground systems that are in direct support of space flight operations (see NPR 8820.2, Facility Project Requirements, for requirements for ground systems).
- e. This directive is applicable to all organizations at GRC's Lewis Field campus and Neil A. Armstrong Test Facility.
- f. This document does not apply to Level I offices or Level II programs hosted and/or managed by GRC on behalf of an Agency Mission Directorate, or to selected reimbursable aeronautics and space flight Projects performed for non-NASA sponsors, as approved by the Center Management Council (CMC). It is expected that reimbursable projects managed under this GLPR would be appropriately tailored to meet the customer's unique requirements. Refer to Section 2.6 for tailoring requirements.
- g. In this GLPR, all mandatory actions (i.e., requirements) are denoted by statements containing the term "**shall**." The term "may" denotes discretionary privilege or permission, "can" denotes statements of possibility or capability, "should" denotes a good practice and is recommended, but not required, "will" denotes expected outcome, and "are/is" denotes descriptive material.
- h. This document applies to the full life cycle of the project, from the assignment of the project to GRC to the finalization of records and archiving project results.
- i. For existing projects and tasks, the requirements of this document are applicable from the effective date of this GLPR.
- j. This directive is applicable to documents developed or revised after the effective date of this GLPR.
- k. In this GLPR, all document citations are assumed to be the latest version, unless otherwise noted.
- l. Where other NASA policies, directives, and other governing documents located in NASA On-Line Directives Information System (NODIS) conflict with this GLPR, those governing NASA documents will take precedence.
- m. If a referenced document is not found in the GRC Business Management System (BMS), Project teams should refer to NODIS and comply with the processes, procedures, and practices in the applicable NASA policy, procedural, or guidance documents.

### **P.3 AUTHORITY**

- a. NASA Policy Directive (NPD) 7120.4, NASA Engineering and Program/Project Management Policy.
- b. NPR 7120.5, NASA Space Flight Program and Project Management Requirements
- c. Glenn Policy Directive (GLPD) 1000.1, GRC Governance and Strategic Management Structure.
- d. GLPR 1280.1, NASA Glenn Research Center Quality Manual.

### **P.4 APPLICABLE DOCUMENTS AND FORMS**

- a. NPD 1040.4, NASA Continuity of Operations (COOP)
- b. NPD 1600.2, NASA Security Policy

- c. NPD 2200.1, Management of NASA Scientific and Technical Information
- d. NPD 2810.1, NASA Information Security Policy
- e. NPD 7120.6, Knowledge Policy for Programs and Projects
- f. NPD 7500.1, Program and Project Life-Cycle Logistics Support Policy
- g. NPD 8820.2, Design and Construction of Facilities
- h. NPR 1040.1, NASA Continuity of Operations (COOP) Planning Procedural Requirements
- i. NPR 1441.1, NASA Records Management Program Requirements
- j. NPR 1600.1, NASA Security Program Procedural Requirements
- k. NPR 2190.1, NASA Export Control Program
- l. NPR 2200.2, Requirements for Documentation, Approval, and Dissemination of Scientific and Technical Information
- m. NPR 2210.1, Release of NASA Software
- n. NPR 2800.1, Managing Information Technology
- o. NPR 2810.1, Security of Information and Information Systems
- p. NPR 7120.8, NASA Research and Technology Program and Project Management Requirements
- q. NPR 7120.10, Technical Standards for NASA Programs and Projects
- r. NPR 7123.1, NASA Systems Engineering Processes and Requirements
- s. NPR 7150.2, NASA Software Engineering Requirements
- t. NPR 8000.4, Agency Risk Management Procedural Requirements
- u. NPR 8705.4, Risk Classification for NASA Payloads
- v. NPR 8715.3, Requesting Relief from Agency Mission Assurance Requirements
- w. NPR 8715.5, Range Flight Safety Program
- x. NPR 8715.6, Orbital Debris Mitigation
- y. NPR 8735.2, Hardware Quality Assurance Program Requirements for Programs and Projects
- z. NPR 8820.2, Facility Project Requirements (FPR)
- aa. NPR 9250.1, Property, Plant, and Equipment and Operating Materials and Supplies
- bb. NPR 9420.1, Budget Formulation
- cc. NPR 9470.1, Budget Execution
- dd. NASA-STD-8739.8, Software Assurance Standard
- ee. GLPD 2810.1, System Security Planning for Information Technology Assets
- ff. GLPR 1440.1, Records Management
- gg. GLPR 5100.1, Procurement
- hh. GLPR 7120.5.20, GRC Project Deviation/Waiver Process

- ii. GLPR 7120.5.30, Space Assurance Requirements
- jj. GLPR 7123.35, Glenn Research Center (GRC) Project Technical Review Procedure
- kk. GLPR 7123.36, Engineering Review Board (ERB) Procedure
- ll. GLPR 8000.4, Risk Management
- mm. GLPR 8553.1, Glenn Research Center Environmental Management System
- nn. GLP-1120.1, Technical Authority Implementation Plan
- oo. GLP-LS-7123.17, Trade Study Handbook
- pp. Alberts, Christopher J., et al.: “Continuous Risk Management Guidebook,” Software Engineering Institute, Jan. 1996
- qq. ANSI/EIA-748, Earned Value Management Systems
- rr. ANSI/PMI 99-001-2017, “A Guide to the Project Management Body of Knowledge—PMBOK Guide,” Seventh Edition, Project Management Institute, Newton Square, PA.
- ss. NASA Special Publication (NASA/SP)—2016-3706, NASA Standing Review Board Handbook, <http://ntrs.nasa.gov>
- tt. NASA/SP—2011-3422, NASA Risk Management Handbook, <http://ntrs.nasa.gov>
- uu. NASA/SP—2010-576, NASA Risk-Informed Decision Making Handbook, <http://ntrs.nasa.gov>
- vv. NASA/SP—2010-3403, NASA Schedule Management Handbook, <http://ntrs.nasa.gov>
- ww. NASA/SP—2010-3404, NASA Work Breakdown Structure (WBS) Handbook <http://ntrs.nasa.gov>
- xx. NASA Cost Estimating Handbook, [http://www.nasa.gov/pdf/263676main\\_2008-NASA-Cost-Handbook-FINAL\\_v6.pdf](http://www.nasa.gov/pdf/263676main_2008-NASA-Cost-Handbook-FINAL_v6.pdf)
- yy. NASA/SP-2014-3705, NASA Space Flight Program and Project Management Handbook, September 2014.
- zz. NASA Form (NF) 1739, NASA Projects – Capitalization Determination Form (CDF)
- aaa. Form GRC 2066, Project Control Board (PCB) Directive
- bbb. NASA Federal Acquisition Agreement (FAR) Supplement (NFS) 1834, Part 1834, Major System Acquisition

## **P.5 MEASUREMENT/VERIFICATION**

- a. Evidence of compliance with this document can be found in the form of a completed Compliance Matrix (see Appendix C) appended to the Formulation Agreement (FA) for Projects in the Formulation phase per NPR 7120.5 and/or the Project Plan (PP) for Projects entering or in the Implementation phase.

*Note that a Compliance Matrix is **not** required for Tasks managed by GRC for a Level III Project customer because that Project is responsible for filling out its own version of a Compliance Matrix.*

- b. In addition to the Compliance Matrix, further evidence can be found in the form of artifacts (i.e., documents, electronic files, etc.) produced by Projects and Tasks that result from

following the requirements listed in Chapter 2 and tailoring and implementing the best practices provided in 3. Typical artifacts might include, but would not be limited to:

- (1) Evidence of Project/Task classification recommended to, and approved by, the GRC SFS Project Review Board (PRB) and concurred with by the CMC.
  - (2) Evidence of a well-understood and agreed-to technical scope of work for the Project/Task, such as might be documented in a System Engineering Management Plan (SEMP), a Safety and Mission Assurance Plan (SMAP), and appropriate requirements documents.
  - (3) Evidence of a well-defined budget and schedule performance baseline, such as a standard Work Breakdown Structure (WBS) and WBS dictionary, a cost estimate and budget phasing plan, a Resource Loaded Schedule (RLS) file, external and internal agreements, and funding authorization.
  - (4) Evidence that technical, budget, and schedule performance baselines are under configuration control.
  - (5) Evidence that Continuous Risk Management (CRM) is being performed.
  - (6) Evidence (1) that periodic reporting to both GRC and customer management authorities is being performed; (2) that, through this reporting, the key performance parameters of technical, budget, schedule, and management progress are being periodically measured; and (3) that appropriate corrective action is being taken, if necessary.
- c. Independent internal and external audits of this procedure are performed as part of the overall GRC Quality System process per GLPR 1280.1.

## **P.6 CANCELLATION**

This GLPR cancels GLPR 7120.5.10A, GRC Space Flight Project Management and Best Practices – Revalidated with Change 5 (07/30/2020), dated April 16, 2014.

**/s/Laurence A. Sivic**

Laurence A. Sivic  
Associate Director

# CHAPTER 1. Introduction

---

1.1 The objective of this document is to provide the requirements, guidance, and best practices required for successful planning and execution of SFS Projects and Tasks at GRC. It defines standards for tailoring Project governance, management oversight, and day-to-day Project management processes to meet the unique characteristics and needs of each Project and Task. This document contains information needed by Project Managers (PMs) and their teams to manage the full range of SFS Projects and Tasks, from the most complex Projects and Tasks that provide systems that fly operational missions in space, to smaller ground-based technology development Tasks that are performed in support of other lead organizations. The content herein is intended for PMs and their team members regardless of experience level.

1.2 This document is structured to allow users to quickly locate the requirements and best practices they need to manage their assigned Projects, as follows:

- a. Chapter 2: GRC Project Management requirements, which contain “*shall*” statements in **typeface**, with the word “*shall*” in bold italics.
- b. Chapter 3: GRC Project Management best practices, which contain “should” statements in normal typeface. Clarifying notes are presented in *nonbolded italics* throughout.
- c. Appendices: Standard templates for use in developing key Project management documents in fulfillment of the requirements and best practices.

1.3 See Table 1 for a quick-look guide to document content applicability to Projects and Tasks.

*Note: Table 1 begins on next page.*

**Table 1. Document Content Applicability Guide for GRC Projects and Tasks**

Table of Contents Heading	Level III Project	Level IV Task
<b>Key: A = Applicable O = Optional</b>		
Preface		
P.1 Purpose		
P.2 Applicability		
P.3 Authority		
P.4 Applicable Documents		
P.5 Measurement/Verification		
P.6 Cancellation		
CHAPTER 1 Introduction		
CHAPTER 2 Project Management Requirements		
2.1 Purpose		
2.2 Governance		
2.2.1 GRC Governance Structure	A	A
2.2.2 Governance Boards	A	A
2.3 Project Classification	A	A
2.4 Delegation of Management Authority	A	A
2.5 Required Responsibilities	A	A
2.6 Tailoring		
2.6.1 Introduction to Tailoring	A	O
2.6.2 Use of Tailoring Tools	O	O
2.7 Technical Authority and Formal Dissent	A	A
CHAPTER 3 Best Practices		
3.1 Introduction and Summary		
3.2 Project/Task Initiation		
3.3 Establish Project/Task Team	A	A
3.4 Scope the Project/Task	A	A
3.5 Define Work Breakdown Structure and Dictionary	A	A
3.6 Develop Acquisition (Make/Buy) Strategy	A	A
3.7 Define and Estimate the Work	A	A
3.8 Develop Budget and Schedule	A	A
3.9 Develop Agreements	A	A
3.10 Develop Formulation Agreement, Project Plan, and Task Plan	A	A
3.11 Establish Technical, Budget, and Schedule Baselines	A	O
3.12 Develop Independent Cost and Schedule Assessments	A	O
3.13 Perform Annual Planning, Programming, Budgeting, and Execution Process	A	A
3.14 Estimate Service Pools and Project Direct Assessments	A	A
3.15 Develop Resource Phasing Plans	A	A
3.16 Acquire Performance-Based Contractor Support	O	O
3.17 Acquire External Contractor Products and Services	O	O
3.18 Perform Continuous Risk Management and Risk-Informed Decision Making	A	O
3.19 Perform Earned Value Management (EVM)	O	O
3.20 Perform Budget and Schedule Variance Analysis	A	A
3.21 Operate Project Control Board	A	O
3.22 Perform Technical Management	A	A
3.23 Perform Periodic Reporting	A	A

3.24 Stoplight Variance Criteria		
3.25 Perform Milestone Reviews	A	O
3.26 Process Deviations and Waivers	A	O
3.27 Archive Project Information, Property Excess, and Closeout Initiation	A	AA
3.28 Develop and Publish Lessons Learned	A	AA
Appendices		
A. Definitions		
B. Acronyms		
C. Project Compliance Matrix and Instructions	A	O
D. Project/Task Scope Summary Template Example	O	O
E. Project Formulation Agreement Template and Instructions	A	O
F. Project Plan Template and Instructions	A	O
G. External Support Agreement Template	A	O
H. Project Milestone Products Maturity Matrix	A	O
I. Project Control Board Charter Template	A	O
Reference Documents		

# CHAPTER 2. Project Management Requirements

## 2.1 Purpose

Chapter 2 defines the applicable requirements for governing and managing an SFS Project or Task. It defines the governance structure and the flow down of management authority that constitute the framework within which SFS Projects and Tasks are initiated, planned, executed, and closed out at GRC. It further defines a standard Project/Task Classification Scheme and tailoring approach that all PMs and their teams are expected to utilize.

## 2.2 Governance

### 2.2.1 GRC Governance Structure

Glenn Policy Directive (GLPD) 1000.1, GRC Governance and Strategic Management Structure, establishes the strategic management and governance structure for the GRC. GLPD 1000.1 can be found in the GRC Business Management System (BMS) Library.)

### 2.2.2 Project Review Board

The GRC SFS PRB is established to support the accomplishment of the GRC mission to successfully manage and execute space flight programs and projects assigned to the Center. The purpose and objectives of the SFS PRB are stated in the PRB Charter which can be found in the GRC Business Management System (BMS Library).

## 2.3 Project/Task Classification

2.3.1 GRC has developed a GRC-unique Project/Task Classification Scheme (Table 2-1) to define expectations regarding governance, management oversight, and process tailoring. Each class (Gold, Silver, and Bronze) is defined by five criteria. To determine the recommended Project or Task class, the PM should identify the column in Table 2-1 where the preponderance of characteristics is located. The column with the most applicable cells is typically the recommended classification. The PM *shall* perform this analysis and bring forward the recommended classification for management concurrence at the PRB and for subsequent concurrence by the CMC. Classification will typically be performed during Project/Task initiation after the work assignment is captured and, subsequently, once per year during the Center’s annual budget-planning cycle. Project/Task classification may change over the course of the Project/Task life cycle if the characteristics change against the five criteria.

**Table 2-1. GRC Space Flight Systems Project and Task Classification Guidance\***  
(Applicable to Projects governed under both NPR 7120.5 and 7120.8)

Criteria†	Project/Task Class		
	Gold	Silver	Bronze
Agency/Program Assigned Role	Project (Lead)	Project (Lead) or Task (Support)	Project (Lead) or Task (Support)
Governing NPR	7120.5	7120.5 or 7120.8	7120.5 or 7120.8
Concept and Development Cost (Phases A–D, Full Cost)	>\$100M	\$20–\$100M	<\$20M
Annual Full-Cost Budget	>\$10M	\$5M–\$10M	<\$5M
Annual FTE	>30	10–30	<10

**Table 2-1. GRC Space Flight Systems Project and Task Classification Guidance\***  
(Applicable to Projects governed under both NPR 7120.5 and 7120.8)

Criteria†	Project/Task Class		
	Gold	Silver	Bronze
Examples‡	FCF (Dev.), Ares I-X, ASRG Flight, CoNNeCT Dev., CPST, ARRM-SEP	SFS Demo, FCF Ops, MDCA Dev., LMM Dev., Orion	SCaN Technology, CoNNeCT Ops, AMPS, SLS, AES Tasks, STMD Projects/Tasks, RPS Tech Adv., SSMLI, ISPT, CTS, HRP Support

**\*How to use guidance in Table 2.1:**

Assigned PM to recommend, for management concurrence, a GRC Project/Task class (Gold, Silver, or Bronze) depending upon which column contains the preponderance of Project/Task characteristics. Classification to be determined initially during Project/Task initiation then reaffirmed annually as part of PPBE process for a new fiscal year.

**†Criteria definitions:**

**Agency/Program Role:** GRC can participate in Projects as the assigned *lead* organization or in Tasks in *support* of a customer.

**Governing NPR:** SFS Projects/Tasks at GRC are governed under either NPR 7120.5 or NPR 7120.8.

**Concept and Development Cost:** This is the estimated cost of the *Concept and Technology Development, Engineering Design, and System Development* phases of the Project/Task from the beginning of Phase A through completion of Phase D. It excludes proposal development and Pre-Phase A Concept Studies as well as Operations and Decommissioning costs (Phases E–F).

**Annual Full-Cost Budget:** This is the Full-Cost Budget, which includes both labor and nonlabor (i.e., procurement) funding allocations for the Project /Task in a given fiscal year.

**Annual FTE:** This is the number of Full Time Equivalent (FTE) civil servants allocated to the Project /Task in a given fiscal year.

**‡Acronym definitions:**

<b>AES:</b> Advanced Exploration Systems	<b>HRP:</b> Human Research Program
<b>AMPS:</b> AES Modular Power Systems	<b>ISPT:</b> In-Space Propulsion Technology
<b>ARRM-SEP:</b> Asteroid Rendezvous and Redirect Mission—Solar Electric Propulsion	<b>LMM:</b> Light Microscopy Module
<b>ASRG:</b> Advanced Stirling Radioisotope Generator	<b>MDCA:</b> Multi-user Droplet Combustion Apparatus
<b>CoNNeCT:</b> Communication, Navigation & Networking Reconfigurable Test bed	<b>RPS:</b> Radioisotope Power Systems
<b>CPST:</b> Cryogenic Propellant Storage & Transfer	<b>SCaN:</b> Space Communications and Navigation
<b>CTS:</b> Compatibility Test Sets	<b>SLS:</b> Space Launch System
<b>FCF:</b> Fluids and Combustion Facility	<b>SSMLI:</b> Self-Supporting Multi-Layer Insulation
	<b>STMD:</b> Space Technology Mission Directorate

**2.3.2 During the initiation of a Project/Task, the PM shall identify the internal GRC classification that is deemed appropriate based on the criteria and classes given in Table 2-1. All Projects/Tasks managed by SFS will use this classification system, unless otherwise directed by the authorizing Mission Directorate (MD), Program Office, or lead center Project.**

- a. In cases of a conflict between the requirements and best practices contained herein and official guidance provided by the authorizing NASA MD, the Program Office for Level III Projects assigned to GRC to lead, or the Project Office (or other non-NASA customer organization) for Tasks assigned to GRC to perform, the customer guidance should take precedence. The PM is expected to identify such conflicts and proactively seek resolution by facilitating a dialogue with the customer and with the responsible GRC management authority.
- b. The PM is expected to present the recommended Project/Task classification to the PRB for approval, and then to the CMC for concurrence if delegated by responsible SFS management to do so. If the PM is not delegated this responsibility, the PRB Chairperson will obtain CMC concurrence.
- c. The SFS Directorate office chief is responsible for reviewing and concurring on the PM’s recommended Project/Task classification prior to presentation to the PRB for approval. If need be, the responsible office chief, in consultation with the Director of SFS, may change the recommended classification to consider other factors such as payload/mission risk

classification per NPR 8705.4, management priority, complexity, visibility, and Center strategy. The Project/Task classification should be reassessed annually because it may change during the life cycle of the Project/Task.

**2.3.3 For Projects led by GRC, the proposed Project/Task classification, including governance approval authority and management reporting cadence, shall be documented in the Project/Task Scope Summary document at the start of Formulation phase, and in the PP at the start of Implementation phase, for approval by the appropriate management authority.**

- a. Section 2.4 (Table 2-2) provides recommended guidance for determining the appropriate management authority at GRC, depending on the Project/Task class.
- b. The Project/Task Scope Summary is an internal GRC planning document for use in capturing the top-level Project/Task characteristics, including the proposed class, for management review and approval. See Appendix D for this template.

**2.3.4 When GRC is assigned an SFS Task for a Project led by another organization, the PM shall negotiate an agreement with the lead PM which outlines the governance hierarchy in relation to GRC Project management requirements.**

## **2.4 Delegation of Management Authority**

2.4.1 The delegation of authority to manage SFS Projects and Tasks is officially documented in a hierarchy of NPDs and NPRs as shown in Figure 2-1. The relationship of this GLPR 7120.5.10 to the higher-tier authorizing agency documents is shown in Figure 2-1.

2.4.2 The SFS Directorate at GRC is organized into customer-facing offices with chiefs who may be delegated authority over a Project/Task that is assigned to their office to manage. The authority to manage SFS Projects and Tasks at GRC is delegated by the CMC to the Director of SFS during the initiation of a Project/Task. The Director of SFS in turn assigns the Project/Task to an office within the SFS Directorate, the chief of which is then responsible for ensuring that the Project or Task is managed in satisfaction of all applicable programmatic, technical, and procedural requirements, including the following specific responsibilities:

- (1) Assign a PM to manage the Project/Task.
- (2) Approve the PP or Task Plan and other appropriate Project/Task documents as required if delegated authority to do so according to Table 2-2.
- (3) Periodically review Project/Task technical, budget, schedule, and managerial progress on behalf of the Director of SFS, as determined during the initiation of the Project/Task.
- (4) Review risks and issues to the Project/Task technical, budget, and schedule performance baselines, including—but not limited to—resource constraints, and escalate to the PRB and CMC as appropriate.
- (5) Review all major changes to Project/Task technical, budget, and schedule performance baselines and recommend whether to go forward for PRB and CMC review, as appropriate.
- (6) Review readiness of the Project/Task to enter major milestone reviews, periodic technical reviews, and Key Decision Points (KDPs).

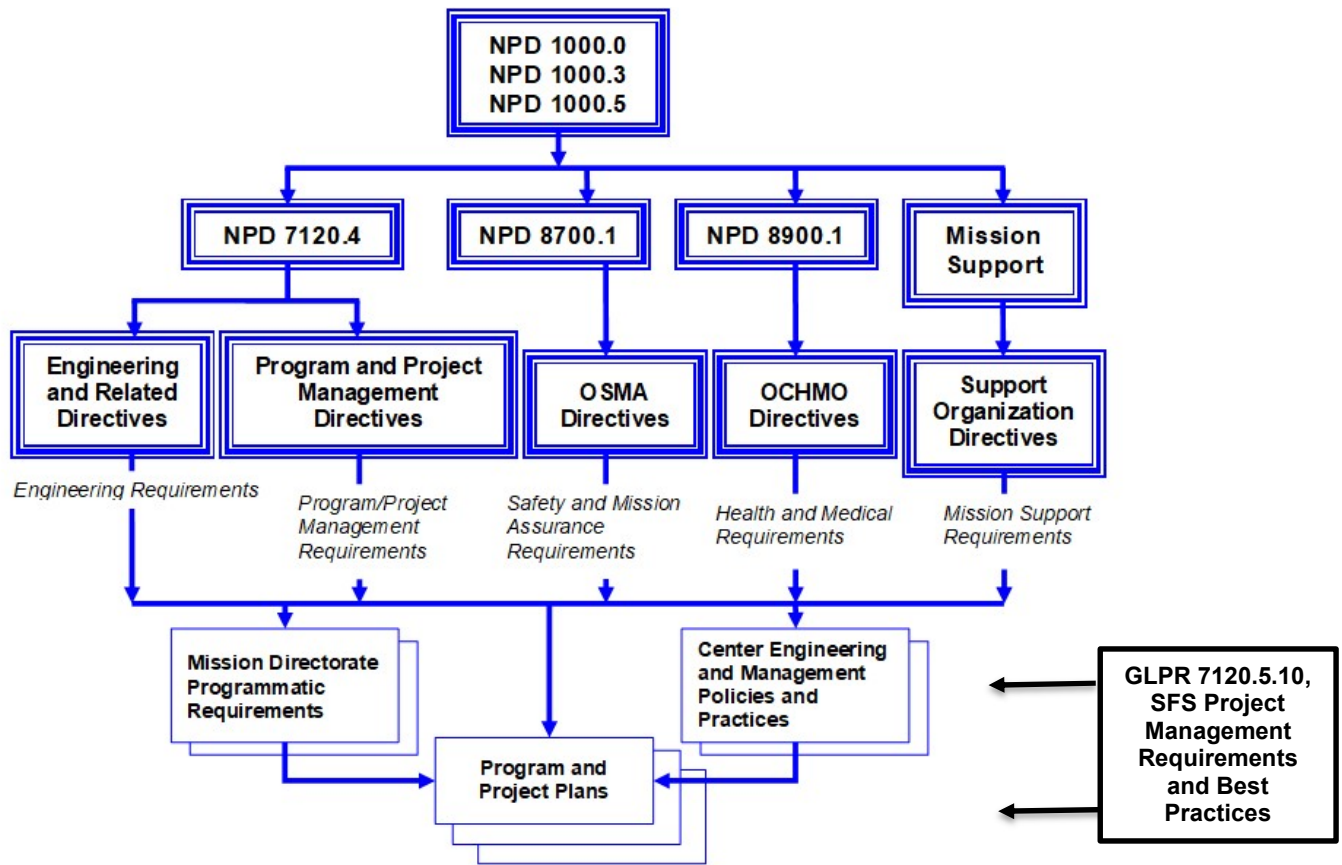

**Figure 2-1. Delegation of Management Authority for SFS Projects**

**Table 2-2. GRC Governance/Approval Authority Guidance<sup>a</sup>**

Product <sup>a</sup>	Project/Task Class <sup>b</sup>		
	Gold	Silver	Bronze
Formulation Agreement (FA), Project Plan (PP)	A <sup>c</sup>	M → M Div <sup>e</sup>	M Div
External Support Agreement (ESA)/Task Plan <sup>d</sup>	-	M Div	M Div
Systems Engineering Management Plan (SEMP)	L	L	L <sup>f</sup>
Safety and Mission Assurance Plan (SMAP)	Q	Q → Q Div <sup>e</sup>	Q Div <sup>f</sup>
Milestone Review Plan/Terms of Reference (TOR) <sup>g</sup>	M/L	M/L Div	M/L Div <sup>h</sup>
Milestone Review Readiness and Results <sup>g</sup>	A <sup>c</sup>	M/L	M/L Div <sup>f</sup>
Other Project/Task PRB Triggers per para. Section 2.2	M	M	M Div <sup>f</sup>

<sup>a</sup>Products listed are those that require approval or concurrence above the PM level.

<sup>b</sup>Key:

A = Center Director, advised by the CMC

M = Code M Director, advised by the PRB

L = Code L Director, advised by the EMB

Q = Code Q Director, advised by the Safety and Mission Assurance Board (SMB)

Div = Division/ Office Chief

<sup>c</sup>Any Gold FA, PP, and Milestone Review readiness/results requiring an approval outside of GRC (i.e., at NASA Headquarters or a Program Office located at another center) should be approved by the GRC Center Director, or his designee, prior to submitting it for approval outside the Center.

<sup>d</sup>A Task Plan is a simplified PP tailored for Silver/Bronze Class Projects/Tasks and is used when more definition is required than what the ESA in Appendix G allows for. Project/Task Plan tailoring is encouraged and should be performed in consultation with the higher-tier customer office and the responsible GRC approving authority as shown in this table.

<sup>e</sup>Indicates approval may be delegated from the director-for to the responsible division or office chief.

<sup>f</sup>As required.

<sup>g</sup>See GLPR 7123.35, Section 2.2, Convening Authorities for more details.

## 2.5 Required Responsibilities

The PM assigned to manage the Project/Task is responsible for fulfilling the following requirements over the life cycle of the Project/Task. **The PM shall:**

- a. **Provide a recommended technical, budget, and schedule performance baseline for the Project/Task to the governing authority for approval in support of the annual budget cycle, at a minimum, and at other key points in the Project/Task life cycle, such as when entering milestone reviews and at KDPs.**

*Note: Best practices for developing the initial budget and schedule estimates are provided in Section 3.7; and Section 3.11 provides guidance for establishing technical, budget, and schedule baselines.*

- b. **Manage and control the Project/Task technical, budget, and schedule performance baseline during execution using a PCB, or equivalent.**

(1) The best practices for chartering and operating a PCB are provided in Section 3.21.

(2) For smaller Projects and Tasks that do not warrant establishing a PCB, the PM may elect to provide the equivalent configuration control by issuing directives, or other guidance to the team, under his/her signature alone.

- c. **Periodically report the status of technical, budget, and schedule performance against plans to the appropriate GRC management authority.**

(1) Table 2-3 provides recommended guidance for Project/Task routine reporting depending on Project/Task class. In this context, reporting means any direct report from the PM, or designated team members, to both GRC and customer management authorities, through which the key performance parameters of technical, budget, schedule and management progress are being periodically measured and during which discussion of major risks and issues is being held.

(2) Note that the recommended reporting level and cadence in Table 2-3 is for internal GRC governance and management oversight only. It does not supersede reporting requirements established by the higher-tier programmatic customer. In addition, when a Project/Task is required to report internally to GRC management authority and externally to the programmatic customer, it is good practice for the Project/Task to report internally at GRC in advance of the external reporting, in any given period. The rationale for this is to ensure that the highest possible quality report is provided to the external customer and that any new issues since the last report are brought to GRC management's attention, and potential quick resolution, before they are released outside the Center.

(3) The Governance Council/Board listed in Table 2-3 is responsible for providing the Project/Task with the required information needed and the expected schedule for reporting.

(4) Table 2-3 is recommended guidance only. The PM is expected to proactively facilitate a dialogue with both the customer and with the GRC management authority to ensure that periodic reporting requirements are streamlined to the maximum degree possible. Once agreement is reached among all parties, the reporting requirements should be documented in the PP or equivalent.

**Table 2-3. GRC Periodic Reporting Guidance**

Governance/Management Authority	Project/Task Class		
	Gold	Silver	Bronze
CMC	Gold Project Reports Monthly	Silver Project Reports— Quarterly	(b)
SFS Directorate	Project Office Status <sup>c</sup> — BiWeekly	Project Office Status <sup>c</sup> — BiWeekly	Project Office Status <sup>c</sup> — BiWeekly
Responsible Code M Project Office <sup>d</sup>	Monthly	Monthly	(b)
EMB	Biweekly <sup>e</sup>	Biweekly-Monthly <sup>e</sup>	Monthly <sup>e</sup> → Quarterly <sup>e</sup>
SMB	Monthly	Monthly	Monthly

<sup>a</sup>Director of SFS, or his designee, typically reports summary status of key Projects/Tasks across the SFS Portfolio monthly to the CMC. In addition, Gold Projects/Tasks are expected to report monthly to the CMC, and Silver Projects/Tasks are expected to report every 3 months to the CMC.

<sup>b</sup>Determined by delegated GRC management authority, either the Director of SFS or the responsible SFS office chief.

<sup>c</sup>See Section 3.23 Periodic Reporting.

<sup>d</sup>Suggested cadence based on various Project/Task factors as determined by the EMB. Frequency may vary as determined by the EMB.

<sup>e</sup>SMA Mission Assurance Manager reports summary status of key Projects/Tasks across the SFS Portfolio monthly to the SMB. Chief SMA Officers report summary status as determined by the Safety and Mission Assurance Board (SMB).

- d. For Projects responsible for delivering flight hardware and/or software, the PM **shall** complete a System Acceptance Review (SAR) and a Pre-Ship Review (PSR), or equivalent, prior to shipment and/or delivery of the flight product(s).

*Note: While a PSR is not an Agency requirement, it is utilized at GRC as a final GRC management review of the project readiness and results in a decision by Center Management to ship. The PSR Board is chaired by a management representative from the SFS Directorate, with Board members including a management representative from the Research and Engineering Directorate and the Safety and Mission Assurance Directorate. The Board may also include a science/technology representative from the Research and Engineering Directorate as appropriate. As a result of successful completion of SAR/PSR, authorization is given to ship the hardware to the launch site or operational facility - or store the hardware - and to install software and hardware for operational use.*

*(1) The SAR will be conducted in accordance with NPR 7123.1*

*(2) The PSR will be conducted in accordance with GLPR 7123.2, section 2.10.7.*

- e. **Plan for and follow appropriate closeout procedures and best practices at the completion of the Project/Task to ensure an orderly shutdown and archiving of assets.**
  - (1) Because each Project and Task is different, the PM should determine the appropriate procedures to follow based on the Project/Task level of documentation, assets, and facility usage.
  - (2) Section 3.27 provides a reference for some of the common activities that the PM should consider as part of closeout.

## 2.6 Tailoring

### 2.6.1 Each Project *shall* complete and attach a Compliance Matrix (see Appendix C) to the FA for Projects in Formulation or to the PP when Projects reach Implementation.

- a. Projects should follow the tailoring process in NPR 7120.5, Section 3.5, at the start of the Project. Tailoring is used to lean out the needed programmatic procedural requirements and processes, and associated costs, to perform the functions necessary to manage the Project/Task.
- b. It is NASA policy that all prescribed requirements (requirements levied on a lower organizational level by a higher organizational level) be complied with unless relief is formally granted. Policy also recognizes that each Project has unique aspects that should be accommodated to achieve mission success in an efficient and economical manner. Tailoring is the process used to adjust or seek relief from a prescribed requirement to meet the unique needs of a specific Project/Task. Tailoring is both an expected and accepted part of establishing proper requirements.
- c. GRC recommends using the process described in NPR 7120.5, Section 3.5.3. Other acceptable methods to submit deviations or waivers for approval are described in NPR 7120.5, Sections 3.5.4, 3.5.5, and 3.5.6.

*Note: The discussion above relates to programmatic procedural requirements tailoring. A different process is to be followed for processing Deviations and Waivers (DWs) to engineering and other technical requirements. That process is described in Section 3.26 of this GLPR.*

### 2.6.2 Use of Tailoring Tools

GRC has developed a Requirement/Document Tailoring Tool that uses a Microsoft (MS) Access database to aid in identifying appropriate requirements based on Technology Readiness Levels (TRLs), risk classification, cost, and other factors that may be used to aid in tailoring.

Documents associated with those requirements are identified. The tool can be found here:

<https://nasa.sharepoint.com/sites/SFS-ePMS/SitePages/SFS-Tailoring-Tool.aspx>

## 2.7 Technical Authority (TA) and the Formal Dissent Process

GRC Projects and Tasks, as represented by the PM, *shall* follow the TA and Formal Dissent process established in GLP-1120.1.

# CHAPTER 3. Best Practices

---

## 3.1 Introduction and Summary

This chapter contains a series of procedural descriptions and best practices that constitute the processes that GRC has established for PMs and their teams to implement in order to ensure sound management of space flight systems Projects and Tasks assigned to GRC. These best practices are derived from NASA agency and aerospace industry standard practices that have proven highly effective over many years of use. They also reflect current GRC business practices. Although not considered mandatory procedural requirements, GRC PMs are highly encouraged to tailor and apply these practices as appropriate to their Projects and Tasks. The best practices are organized into four generic functional groupings derived from ANSI/PMI 99-001-2021: initiation, planning, execution, and closeout. Note that these generic groupings are not intended to correspond to the standard NASA project life-cycle phases because any given best practices process described in the rest of this document may be used more than once during a Project/Task life cycle. In fact, many are intended to be used continuously as the Project/Task is managed daily, or on an annual basis in conjunction with the annual NASA budget cycle.

## 3.2 Project/Task Initiation

### 3.2.1 Capture Project/Task

3.2.1.1 Purpose: The purpose of this section is to describe the two primary ways that a new SFS Project/Task assignment is captured by GRC: directed work and formal competition.

#### 3.2.1.2 Rationale

- a. This section provides background information on how new SFS work assignments are captured by GRC using standard best practices.
- b. This section is for GRC standard operating practice and does not satisfy any requirements in the Compliance Matrix (Appendix C).

### 3.2.2 Capture Project/Task Process

3.2.2.1 Space flight Projects/Tasks are captured in one of two ways, either via directed work or formal competition:

- a. **Directed Work.** SFS Projects are typically initiated within a NASA MD and/or Program Office after a period of early concept studies referred to as Pre-Phase A. Depending on the technical and programmatic complexity of the conceptual mission, Pre-Phase A can extend for multiple years before new start funding is programmed and Authority to Proceed (ATP) is successfully obtained. NASA MDs and their Program Offices typically direct a majority of programmatic assignments (i.e., Projects and Tasks) to NASA centers without requiring a formal competitive process. Work is directed to a given center based on a variety of factors, such as technical core competency, management experience, and past track records. Although a formal competition may not be conducted before a Project/Task assignment is finalized, an informal proposal process may be utilized by the MD/Program Office to obtain cost and schedule estimates and to ascertain the level of management commitment between centers competing for the directed work. Thus, capturing directed work requires the establishment and maintenance of healthy working relationships at both the organizational and personal levels. The capture team may also benefit from utilizing elements of a formal

competition proposal process as described in paragraph b of this subsection, together with cost and schedule estimating best practices outlined in Sections 3.7 and 3.8.

- b. **Formal Competition.** The SFS Directorate has created a process for winning competitive space flight assignments that NASA solicits via formal Announcements of Opportunity (AOs). The information is contained on the SFS New Business Web site. The Web site provides resources and tools for identifying prospective opportunities, developing competitive proposals, and capturing new work assignments. Past proposal efforts and cost and schedule planning tools can be obtained on the Web site.

*Note: This information is competition sensitive and may not be downloaded directly. Contacts have been listed to aid in locating and obtaining information. The Enterprise Project Management System (ePMS) Web site can be found here: <https://nasa.sharepoint.com/sites/SFS-ePMS/SitePages/New-Business-Proposal-Development.aspx>.*

3.2.2.2 Once a new Project/Task work assignment is captured by GRC, it will typically be documented via an approved Formulation Authorization Document (FAD) (if a Level III Project executed for a NASA Level II Program Office) or some other written documentation from the Project/Task customer.

### 3.2.3 Additional Resources

A general description of Pre-Phase A activities is provided in Section 4.3.1 of the “NASA Space Flight Program and Project Management Handbook” available on NODIS.

## 3.3 Establish Project/Task Team

**3.3.1 Purpose.** This section provides guidance for defining the “multi-organizational” Project/Task team by function, and for recruiting core team members to fulfill key leadership roles.

### 3.3.2 Rationale

- a. Defining and documenting a “multi-organizational ” Project/Task team structure enables the PM to use sound organization design principles (listed in Table 3-2 in Section 3.7) in assigning clear Roles, Responsibilities, Authorities, and Accountability (RRAA) to Project/Task team members. It also allows the PM, the team members, and key stakeholders external to the Project/Task to visualize how the team is organized and to understand the nature of the interrelationships between functions and/or roles (i.e., the “boxes” on the organizational chart).
- b. This section relates to Number 12 (NPR 7120.5 requirement 2.2.1) in the Compliance Matrix (Appendix C).

### 3.3.3 Team Establishment Process

#### a. Define Project Task Team Organization

GRC has defined a standard organization structure for SFS Project/Task multi-organizational teams, as shown in Figure 3-1. Key features of this structure that are important for PMs to implement in their teams follow:

- (1) Top-level leadership of the Project/Task is performed by a triumvirate of three roles that must be filled by different individuals to maintain separation of programmatic and technical authorities:
  - (a) PM, typically from the SFS Directorate (Code M)
  - (b) Chief Engineer (CE) or a PLE (Product Lead Engineer), typically from the Research and Engineering Directorate (Code L). The GRC projects and programs relying on Code L for Technical leadership will be assigned either a CE or a PLE by Directorate management. Determination of whether CE or PLE is assigned for technical leadership of a project is determined by management considering, primarily, the project's technical scope, risk, and mission criticality. Project specific factors are also considered in making this determination. CEs are typically assigned to larger, complex, multi-disciplinary programs/projects. PLEs are typically assigned as technical leads for smaller, discipline focused projects or the leads for a subsystem for a larger project.
  - (c) Chief SMA Officer (CSO), typically from the SMA Directorate (Code Q). For smaller projects or tasks, an SMA Lead is assigned in lieu of the CSO.
- (2) The CE maintains an independent relationship with the Center and Agency Engineering TA. Likewise, the CSO maintains an independent relationship with the Center and Agency SMA TA, as shown by the dashed lines up and out of the team organization chart.
- (3) Portfolio Integration Lead is shown in Figure 3-1 as lead for the Project Planning and Control (PP&C) functions. Portfolio Integration Lead is defined in Section 3.3.3.

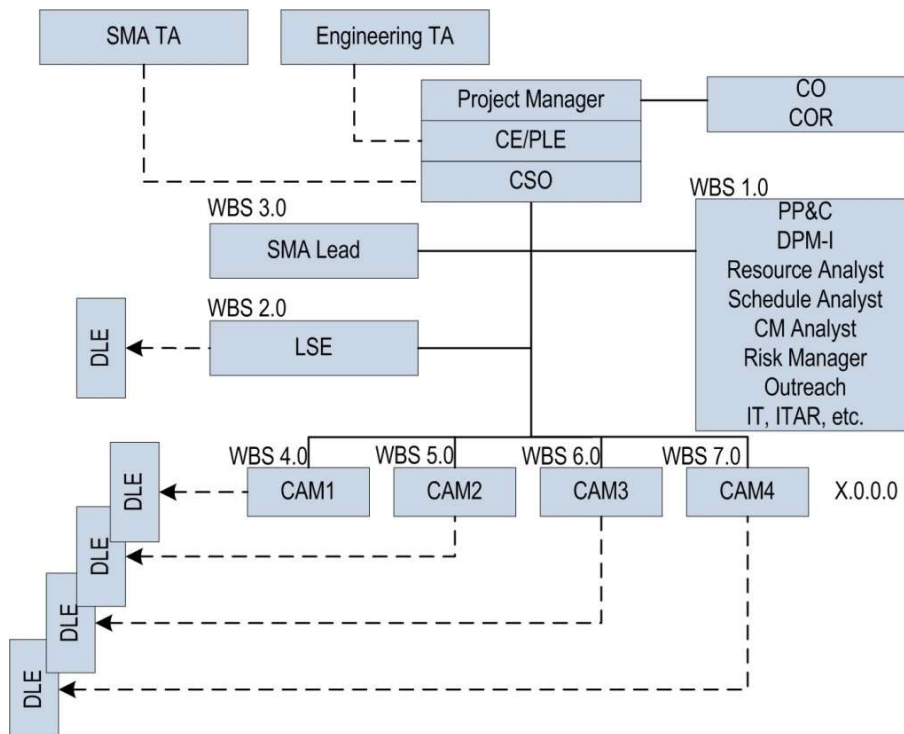

**Figure 3-1. Standard Project/Task Organization Template for Space Flight Projects**

(Contracting Officer (CO), Contracting Officer's Representative (COR), Lead Systems Engineer (LSE), Configuration Management (CM), information technology (IT), International Traffic in Arms Regulations (ITAR), Discipline Lead Engineer (DLE), Control Account Manager (CAM))

(4) Leadership of each WBS element 4.0 through 11.0 should be assigned to a Control Account Manager (CAM). This best practice also enables strong planning and control by allowing the PM to assign work planning and budget and schedule estimating to the CAM responsible for a specific WBS element. Similarly, control and routine reporting of progress and issues flows back up to the PM from the CAM.

(a) Each CAM should maintain a matrix reporting relationship with a respective Discipline Lead Engineer (DLE) to ensure line management and peer review of engineering deliverables produced within the CAM’s team.

(b) See Section 3.3 for the NPR 7120.5 standard WBS element definitions.

*Note: For any Class Project or Task, a single person may perform multiple functions and assume multiple leadership roles in the multi-organizational team. The key exception to this is the PM, CE, and CSO, who must be separate individuals coming from the program management, engineering, and SMA organizations, respectively.*

**b. Assign Core Team**

(1) The PM, in close consultation with the CE and CSO, should utilize the standard Organization Template shown in Figure 3-1 to develop the Project/Task organizational structure, using both the Project/Task WBS and the guidance provided in Table 3-1 depending on the Project/Task Class. This structure should be documented and described in the FA and PP when those documents are drafted.

**Table 3-1. Project/Task Core Team Role Guidance**

Project/Task Role Key: * A = Applicable O = Optional	Project/Task Class		
	Gold	Silver	Bronze
Project Manager (PM)	A	A	A
Deputy Project Manager (DPM)	A	O	
Principal Investigator (PI)	†	†	†
Chief Engineer (CE)	A	A	O
Product Lead Engineer (PLE, in lieu of CE)		O	A
Lead Systems Engineer (LSE)	A	A	O
Chief Safety and Mission Assurance (SMA) Officer (CSO)	A	A	
SMA Lead (in lieu of CSO)			A
Integration Manager (IM)	A	O	
Risk Manager	A	A	O
Configuration/Data Manager (C/DM)	A	A	A
Scheduler	A	A	A
Budget/Resource Analyst (RA)	A	A	A
Control Account Managers (CAMs)/WBS Element Leads	A	A	O

\*A = Applicable: Function is typically needed and may be performed by full-time or part-time/shared staff tailored to the unique needs and available budget of each Project/Task.

O = Optional: Function may or may not be needed or may be fulfilled without directly assigning a Project/Team member. † If required for Projects/Tasks with science or advanced technology development content.

(2) The PM, CE, and CSO should lead the effort to define the required core team roles and to work with line management to recruit individuals to fill those roles necessary to complete Project/Task planning activities defined in Sections 3.2, 3.3 and 3.4.

*Note: Project/Task team roles and staffing levels are expected to evolve over the life cycle of the Project/Task, and the changes should be documented in any revisions to the PP that are issued at appropriate KDPs or other milestone points in the Project/Task.*

- (3) Key responsibilities of each core team leadership role listed in Table 3-1 are summarized as follows:
- (a) **Project Manager (PM)**—The PM is the leader of the multi-organizational Project/Task team and, in this leadership role, serves as the decision-making authority over all aspects of the project, both programmatic and technical. In addition to the required responsibilities in Sections 2.2 and 2.5, the PM is delegated the following responsibilities for managing the SFS Project/Task, including but not limited to:
    - (i) Defining the Project/Task scope, content, and key stakeholder requirements and expectations during initiation per Sections 3.2, 3.3 and 3.4, 3.5 and documenting them in the Project Scope Summary (see Appendix D) or equivalent document for review and approval by the responsible management authority.
    - (ii) Obtaining ATP with the Project/Task, developing the FA, and providing input for the Decision Memorandum issued by the Program Office or equivalent next higher tier programmatic authority, documenting the outcome of KDP reviews.
    - (iii) Establishing the technical, budget, and schedule performance baseline plan per Section 3.11, against which Project/Task progress is measured.
    - (iv) Maintaining configuration control of the technical, budget, and schedule performance baseline, and specific artifacts that constitute that baseline, using a PCB per Section 3.21 or equivalent.
    - (v) Ensuring that the principles of CRM and Risk-Informed Decision Making (RIDM) are implemented across all Project/Task activities per Section 3.18.
  - (b) **Deputy Project Manager (DPM)**—The DPM serves as the deputy to the PM to carry out RRAAs delegated by the PM. Manages Project/Task activities, and makes decisions with the authority of the PM when acting in the absence of the PM.
  - (c) **Principal Investigator (PI)**—The PI serves as the lead scientist or researcher on the Project/Task team responsible for defining science requirements, preparing and maintaining the science requirements documents, and advising the PM on science-related matters throughout the Project/Task life cycle.
  - (d) **CE**—The CE serves as the technical lead of the program/project engineering team and the delegated system-level Engineering Technical Authority (ETA) for the program/project. The CE is responsible for: (a) leading the program/project technical team in concert with the PM; (b) developing the approaches, methods, responsibilities and processes for implementing the technical effort; (c) developing and approving deviations/waivers for engineering requirements; (d) facilitating the Formal Dissent process; and (e) ensuring that the Project and technical planning is consistent with Agency and Center engineering design processes, specifications, rules, best practices, and other guidelines, necessary to fulfill mission performance requirements for the Project/Task.
  - (e) **PLE**—The title of PLE may be substituted for CE for Projects/Tasks that are characterized by a limited technical scope, such that the overall technical leadership typically performed by a CE can be performed by a PLE coming from a core competency division rather than by the

GRC Office of the Chief Engineer (OCE). The PLEs are funded by the Project/Task so they do not have that ETA responsibility: the assigned DLE of the PLE serves as ETA for the Project/Task.

- (f) **Lead Systems Engineer (LSE)**—The LSE leads the Project/Task systems engineering and integration (SE&I) activities and serves as the CAM for WBS element 2.0. The LSE is responsible for the initiation and implementation of the assigned Project/Task SE&I element including: the technical integrity, performance, and mission success of the SE&I element while meeting cost and schedule commitments.
- (g) **CSO**—The CSO serves as the Project/Task level SMA TA. The CSO ensures that the technical planning is consistent with Agency and Center SMA design processes, specifications, rules, best practices, and other guidelines necessary to fulfill mission performance requirements for the Project/Task.
- (h) **SMA Lead**—The SMA Lead serves as the CSO for Bronze Class Projects/Tasks, and also serves as the CAM for WBS element 3.0 and is typically provided to the team from GRC's OSMA.
- (i) **Portfolio Integration Lead** – The Portfolio Integration Lead is shown in Figure 3-1 as the lead for a set of PP&C functions. The Portfolio Integration Lead is typically assigned to a particular customer-facing project office within the SFS Directorate. As such, the Portfolio Integration Lead will have multiple Projects/Tasks to oversee and so will not be dedicated to a single Project/Task. As an alternative, a dedicated Project/Task Integration Manager (IM) position may be established for Projects that have been classified as Gold or selected Silver per Section 2.3 that require and can afford full-time PP&C leadership. The PP&C functions have been defined by HQ to include:
  - (i) Cost estimation.
  - (ii) Resource management and budget analysis.
  - (iii) Schedule planning and analysis.
  - (iv) Configuration and Data Management.
  - (v) Acquisition and contract management.
  - (vi) Risk management.
  - (vii) User needs assessment.
  - (viii) Other, such as compliance with International Traffic in Arms Regulations (ITAR) requirements, information technology (IT) and public outreach and media management.
- (j) **Configuration/Data Manager (C/DM)**—The C/DM will implement GRC Configuration and Data Management processes to control all required documentation and Project/Task records. In addition, the C/DM may serve as Executive Officer of the PCB. See Section 3.21 for more information.
- (k) **Scheduler**—The Scheduler is responsible for performing schedule planning, tracking, and variance analysis and reporting using standard tools and best practices defined by the Program/Project Integration Office of the SFS Directorate. The Scheduler is expected to work closely with the PM, the CE, the CSO, Resource Analyst, (RA) and each CAM to assist them in defining the step-by-step work tasks and capturing this detail in the standard

scheduling software tool. The Scheduler is required to be expert in critical path analysis technique, Resource Loaded Schedule development, all scheduling best practices as defined in the “NASA Schedule Management Handbook,” and the standard tools defined for use on SFS Projects/Tasks. See Sections 3.8 and 3.20 for additional key Scheduler responsibilities.

- (l) **RA**—Roles and responsibilities of the RA have been established via a Service Level Agreement (SLA) between the SFS Directorate and the Office of the Chief Financial Officer (OCFO). The following summarizes the key RA responsibilities defined in the SLA:
  - (i) Receiving and distributing funds from the customer Program Office or HQ.
  - (ii) Assisting with CS workforce labor utilization planning, and monitoring, analyzing, and reporting labor actuals versus plan for periodic reporting.
  - (iii) Ensuring funding is obligated in advance of costing on all contracts.
  - (iv) Assisting with budget development, including supporting the annual Planning, Programming, Budgeting, and Execution (PPBE) submissions to the center OCFO and external customer organizations, and related phasing plan submissions in coordination with the PM and scheduler (depending on the project size and organization).
  - (v) Monitoring of Purchase Requisitions (PRs) to ensure timely obligation of funding.
  - (vi) Tracking, pulling reports, and performing variance analysis on the utilization of the following resources, by Project/Task WBS element:
    - (1) CS Full Time Equivalent (FTE) heads
    - (2) Performance Based Contractor (PBC) Work Year Equivalent (WYE) heads
    - (3) Funding (for FTE labor and travel, WYE labor and travel, procurements, and Other Direct Costs (ODCs) such as GRC program direct assessments (PDAs)).
- (m) **IM**—The IM serves as the PP&C lead for, coordinating and integrating the functions shown in the PP&C box in Figure 3-1 and described under the Portfolio Integration Lead in item (9) in this section. The IM essentially serves as the Portfolio Integration Lead for Projects that have been classified as Gold or selected Silver per Section 2.3. In addition, the IM may perform key programmatic and technical integration functions, such as working with the GRC Procurement Office to lead major acquisitions or serving as the Contracting Officer’s Representative (COR) for key contracts.
- (n) **CAM/WBS Element Lead**—The CAM or WBS element lead (synonymous) is responsible for the leadership of an assigned Project/Task WBS element. The PM, working in partnership with the CE and CSO, should identify the appropriate core competency organizations to supply the needed CAMs. CAMs may also come from any other organization provided that the organization has the primary responsibility for completing the work. Specific CAM/WBS lead responsibilities include:
  - (i) Plan and manage the technical scope of work assigned to his or her Control Account (CA).
  - (ii) Develop Statements of Work (SOWs), oversee and review contractor progress and deliverables, and serve as the COR, as appropriate.
  - (iii) Identify and report potential risks and issues associated with work in his or her assigned CA.

- (iv) Oversee planning and implementation of Project/Task assignments within his or her CA.
- (v) Plan, coordinate, review, submit, and defend budget requests and related documents.
- (vi) Proactively identify budget threats and opportunities and create and submit lien requests to the PCB.
- (vii) Plan out Tasks, durations, and logic for incorporation into and maintenance of schedules and Earned Value Management (EVM) databases.
- (viii) Participate in weekly schedule integration meetings.
- (ix) Monitor budget and schedule execution against the baseline performance plan, and report progress to satisfy weekly, monthly, and quarterly reporting requirements.
- (x) Serve as a member of applicable Project/Task governance boards, panels, and working groups, if and when invited to do so.

### 3.3.4 Additional Resources

NASA field centers are typically organized as matrix organizations in which PMs are assigned by a Program/Project Management Office to lead individual Projects/Tasks that are staffed by personnel with required technical skills needed by line management of “performing” organizations. In this sense, PMs lead multi-organizational teams, not discrete teams with organizational standing or supervisory authority. The design of the multi-organizational Project/Task team should be performed with appropriate planning and attention to the principles of sound organization design as listed in Table 3-2.

**Table 3-2. Project/Task Team Organization Design Principles**

Principle	Typical Application
<b>Develop and document an Organizational Breakdown Structure (OBS)</b>	A written OBS dictionary should be developed to describe the key Roles, Responsibilities, Authorities, and Accountability (RRAAs) assigned to each functional box and/or staff position.
<b>Assign clear RRAAs</b>	Clearly written RRAAs should be defined for each functional box and/or leadership role. This helps to eliminate any potential duplication or overlap between the functions and serves as a key educational or team training document.
<b>Ensure OBS alignment with the WBS</b>	In general the OBS should mirror the WBS. This is reflected in the organizational structure template in Figure 3-1 by the assignment of WBS element numbers to specific functional boxes. A Responsibility Assignment Matrix, which documents the assignment of OBS elements to WBS elements, can also be developed for more complicated Gold Class Projects, if needed.
<b>Differentiate between functional and product RRAAs</b>	Both the OBS and WBS element definitions should differentiate between boxes on the team organization chart for personnel and groups that perform ongoing continuous functions (e.g., Project planning and control or Project integration) and those which produce and deliver the space flight hardware or software “system” and its subsystems and/or elements. For large or complex systems, the product-delivery boxes can also be further defined using a Product Breakdown Structure (PBS).
<b>Establish a manageable span of control</b>	The team should be organized in a way that balances the managerial span of decision making and control at each level. This avoids potential bottlenecks in data flow and decision making at any one functional box. For example, a Gold Class Project may establish multiple deputy positions at key levels, such as assigning separate Deputy Project Managers (DPMs) for flight hardware and ground operations.
<b>Provide for independent TA lines</b>	The Project/Task organization chart should identify independent TA reporting flows as dashed lines flowing up and out of the Project. At a minimum, an engineering TA and an SMA TA line of independent reporting should be shown for the typical GRC space flight Project. The template shown in Figure 3-1 also shows a technical DLE reporting relationship typical of GRC’s approach to Engineering TA for SFS Projects. Other TAs may apply to certain Projects/Tasks to meet unique customer requirements.
<b>Show external relationships</b>	In addition to TAs, other important external stakeholder relationships should be explicitly shown. This serves to both identify the point of entry into the Project/Task team and/or box with primary responsibility to manage the organizational interface and to emphasize to all viewers that the team recognizes the

	importance of managing external relationships. These could include key customers, other Government agencies or universities, a Standing Review Board (SRB) advising the Project, commercial partners, or prime and subcontractors involved with the Project/Task.
<b>Match the organization design to the Project/Task and mission needs</b>	In general, the multi-organizational Project/Task team should be as simple and as leanly staffed as required to get the job done. Positions should <i>not</i> be created with an individual in mind, but rather with the needed functions and role requirements in mind. Only then, should the recruiting and selection of candidates to fill the functional roles be undertaken.

### 3.4 Project/Task Planning

This section defines the procedures to be used by GRC SFS Projects and Tasks to scope the Project/Task, develop the make/buy acquisition strategy, define a WBS and WBS dictionary, define and estimate the work, develop the initial budget and schedule, develop external and internal work agreements, develop control plans, and document this information in appropriate project documentation. A general explanation of planning is provided in the “NASA Space Flight Program and Project Management Handbook” (available in NODIS), Sections 4.3.2 to 4.3.7 (end of Pre-Phase A through Phase B).

*Note: Several of the sections herein utilize the “swim lane” format to show the procedural workflow, which assigns each activity in the process to a function/role (e.g., swim lane) on the Project/Task team. The format also defines the interactions with GRC governance and management authorities at appropriate steps in the process, such as the PRB, EMB, CMC, and line management.*

#### 3.4.1 Scope the Project/Task

3.4.1.1 Purpose. The purpose of this section is to define the inputs, outputs, activities, and roles for core team leadership to initially plan out the Project/Task.

3.4.1.2 Rationale

- a. The PM should perform this process to carefully scope out a new Project/Task, thereby getting the endeavor off to a strong start with a well-developed set of planning documents that have been reviewed and approved by GRC and customer management authorities.
- b. This section provides procedures that comply with requirements 2.3a, 2.3b, and 2.3c. It relates to Numbers 12 and 36 through 43 (NPR 7120.5 requirement 2.2.1 and Table I-4, “Project Management, Planning, and Control Products,” Items 1 through 5) in the Compliance Matrix (Appendix C).

#### 3.4.2 Project/Task Scoping Procedure

**Figure 3-2** shows the initial planning process for an SFS Project or Task at GRC. Each of the activities is described in more detail in this section.

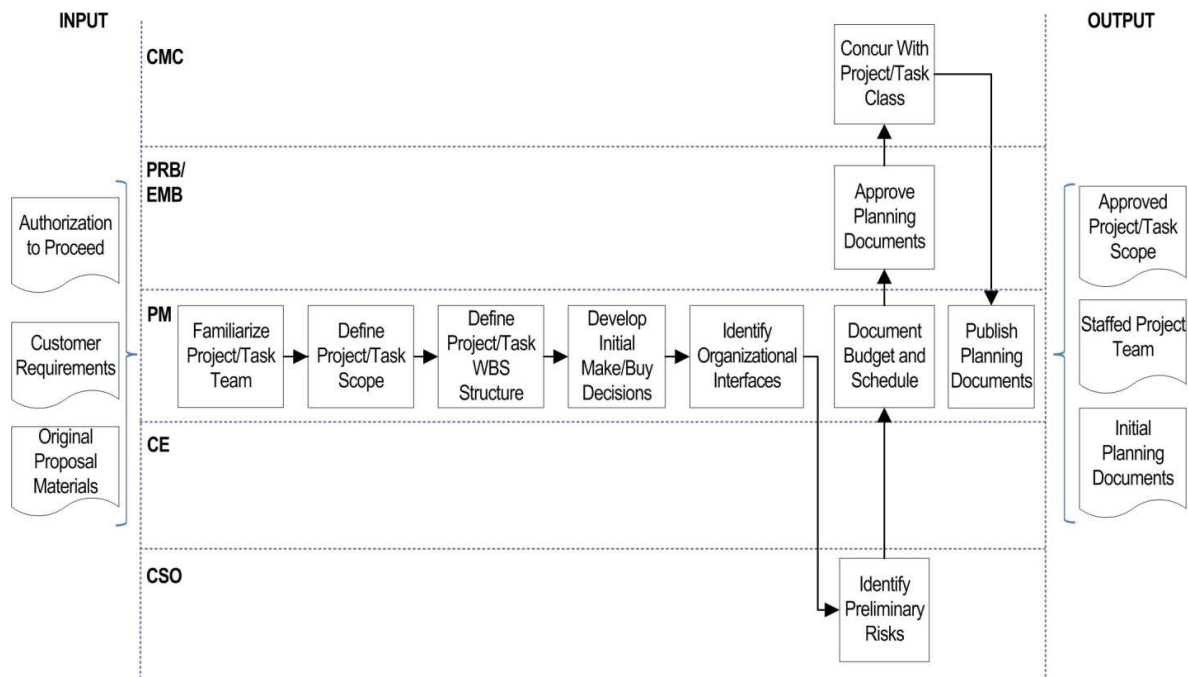

**Figure 3-2. Project/Task Initial Planning Process**

### 3.4.3 Familiarize the Project/Task Core Team

3.4.3.1 Once the core team has been established and assigned per Section 3.3, the PM should collect and provide them all prior developed planning materials including, but not limited to, the following typical products:

- Customer requirements, such as customer needs, goals, and objectives for the Project/Task, top-level requirements and constraints, and mission architectures or system concepts
- ATP and/or initial funding documentation
- Original proposal materials, if developed per Section 3.3 and 3.4.

3.4.3.2 The PM should identify any lessons learned (LL) or best practices applicable to the current effort by using the NASA Engineering Network’s (NEN) Lessons Learned Information System (LLIS), consulting with the GRC Chief Knowledge Officer (CKO)/Knowledge Management (KM) Program, and/or contacting a NASA GRC librarian. (See Figure 3-3.) If applicable lessons are found, they should be shared with the team at this point in the planning process. A best practice for this would be to hold a focused LL “brown bag” or workshop with the core team members to review the lessons and discuss how to apply the learning in the new Project/Task at hand.

*Figure 3-3 on next page*

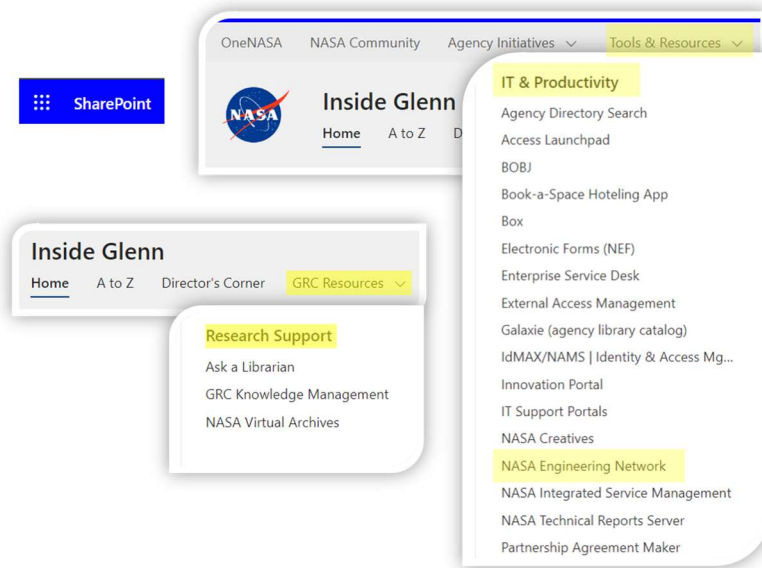

**Figure 3-3. GRC Lessons Learned Resources**

### 3.4.4 Define Scope of Project/Task

The PM should:

- a. Utilize the Project/Task Scope Summary template (Appendix D) to document the key characteristics of the new Project/Task to concisely capture this information on a single page. This summary should be reviewed frequently during the preliminary planning activities as key characteristics may change as the project scope is defined. Typical key characteristics follow:
  - (1) Customer (NASA Mission Directorate, Theme, Program, and Project (for supporting Tasks))
  - (2) Governing NPR (7120.5 or 7120.8)
  - (3) Project class per Section 2.3 herein
  - (4) Customer/stakeholder expectations, such as a Mission Statement, list of needs, goals, and objectives; top-level requirements; and key constraints
  - (5) Reference Mission or System Architecture
  - (6) Key project deliverables
  - (7) Project partners and other external stakeholders
- b. Partner closely with the CE, CSO, and PI to draft the information listed above, so that he/she can proactively engage the customer in a dialogue about these characteristics, with a goal of firming them up as early as possible during preliminary planning of the Project/Task. As drafted and captured on the Scope Summary, these will be high-level scoping statements that describe the proposed Project/Task concept, and they will be further refined during later planning iterations.

### 3.4.5 Define Work Breakdown Structure and Dictionary

The PM, in partnership with the CE, CSO, LSE, the IM (for Gold Class Projects), and the PI (for Projects/Tasks with science content), should develop the first-tier WBS using the process and model SFS WBS defined in Section 3.5. The WBS serves as the backbone of the Project, so

effort and attention to detail is required from the outset of the Project/Task to get this defined accurately. This should include the development of a first-draft WBS dictionary as well. These documents are expected to evolve and grow increasingly detailed during subsequent planning iterations, particularly after all the CAMs have joined the Project/Task team and taken ownership for their respective WBS elements.

### **3.4.6 Develop Initial Acquisition Strategy**

The PM, in partnership with the CE, CSO, LSE, and IM (for Gold Class Projects) and with the PI (for Projects/Tasks with science content), should develop an initial proposed acquisition (make vs. buy) strategy using the process defined in Section 3.6. It is recommended that the PM engage with the Office of Procurement at this point. Specifically, deciding the top-level approach to acquiring the system or other products is an important decision to make early in the planning process because it can drive many subsequent decisions. For example, if the system/product will be made primarily in house, that will strongly influence staffing needs from the GRC engineering and other organizations. At the other end of the spectrum, if the system/product will be bought from an aerospace prime contractor that will require a long procurement timeline, there will be a need to involve the Procurement Office (Code PP) early in the planning process.

### **3.4.7 Identify Organizational Interfaces**

The PM, in partnership with the CE, CSO, LSE, IM (for Gold Class Projects) and with the PI (for Projects/Tasks with science content), should identify key external organizational interfaces across which Project/Task direction, guidance, reporting, and other information will flow over the life cycle of the project. The management of these interfaces should be carefully planned, and they should be explicitly identified on the team organization chart, as discussed in Section 3.2. In addition to the key relationship with the next higher tier Program Office or customer, typical external interfaces might include engineering and SMA TAs, a Standing Review Board (SRB), partners such as PIs or Co-PIs at universities, or Government agencies.

### **3.4.8 Identify Preliminary Risks**

3.4.8.1 The CSO, working closely with the PM, CE, and CAMs, should identify preliminary risks using the risk management approach provided in Section 3.18. Preliminary risks should be identified and documented for each major Project/Task area, including, but not limited to:

- a. Budget
- b. Schedule
- c. Technology maturation and system development approach
- d. Integration, Assembly, Test, and Verification approach
- e. Science

3.4.8.2 If not otherwise provided by the customer, the PM, with the CE and CSO, should also identify a recommended Payload Risk Category per NPR 8705.4 and NPR 7150.2 and document it in the Project Scope Summary, FA, PP, or Task Plan, as appropriate.

### **3.4.9 Estimate Preliminary Budget and Schedule**

3.4.9.1 The PM should obtain the initial total cost and annual fiscal year budget marks from the customer, as well as top-level schedule targets for major system/product deliverables and KDPs. If these are not available from the customer at ATP, then the PM in partnership with the core leadership team should develop draft or proposed marks to initiate the planning process. These will be refined during subsequent planning iterations. In addition, target dates for milestone reviews and KDPs should be proposed. The budget marks and milestone schedule will be used to compare against more detailed budget and schedule estimates developed per Section 3.8.

3.4.9.2 The preliminary budget and schedule marks should be documented in the Project/Task Scope Summary template provided in Appendix D.

### **3.4.10 Review, Approve, and Publish Planning Documents**

The PM should request a decisional review at the PRB to obtain review and approval of the initial planning documents.

### **3.4.11 Establish Configuration Control**

Once the initial project planning documents are approved by the PRB, and the proposed Project/Task Class has been concurred on by the CMC, the PM should publish the planning documents and put them under configuration control as appropriate to the needs and class of the Project/Task. This is an appropriate point to establish the PCB.

### **3.4.12 Additional Resources**

The KM Program/CKO is available to help PMs with KM planning. KM planning includes project **succession/continuity planning** (planning for employee attrition situations like retirees, deployment, long-term leave, even AL) and integrated **LL** collection.

## **3.5 Define Work Breakdown Structure and Dictionary**

**3.5.1 Purpose.** This section describes the process used to define the Project/Task WBS and develop the WBS dictionary, tailored from the Agency standard WBS for space flight projects and a corresponding GRC model WBS dictionary.

- a. Agency standard WBS can be found in NASA WBS Handbook (<http://ntrs.nasa.gov>).
- b. NASA/SP-2014-3705 NASA Space Flight Program and Project Management Handbook provides additional guidance on WBS development.

### **3.5.2 Rationale**

- a. Defining a WBS is a critical function of Project/Task planning and provides the foundation for all subsequent planning by defining all the work elements necessary to deliver the system/product for the customer. The WBS provides a single unifying framework with which to align the budget, schedule, and team organization. It simplifies the organizational interfaces and lines of authority, and it enables accurate accountability and reporting.
- b. This section relates to Numbers 12 and 13 (NPR 7120.5 requirements 2.2.1 and 2.2.2) in the Compliance Matrix (Appendix C).

### 3.5.3 Work Breakdown Structure Development Procedure

3.5.3.1 The PM, with the CE and CSO, should define the WBS using the standard space flight WBS shown in Figure 3-4 as the point of departure. The WBS should be consistent with this WBS model unless the customer requires a different model.

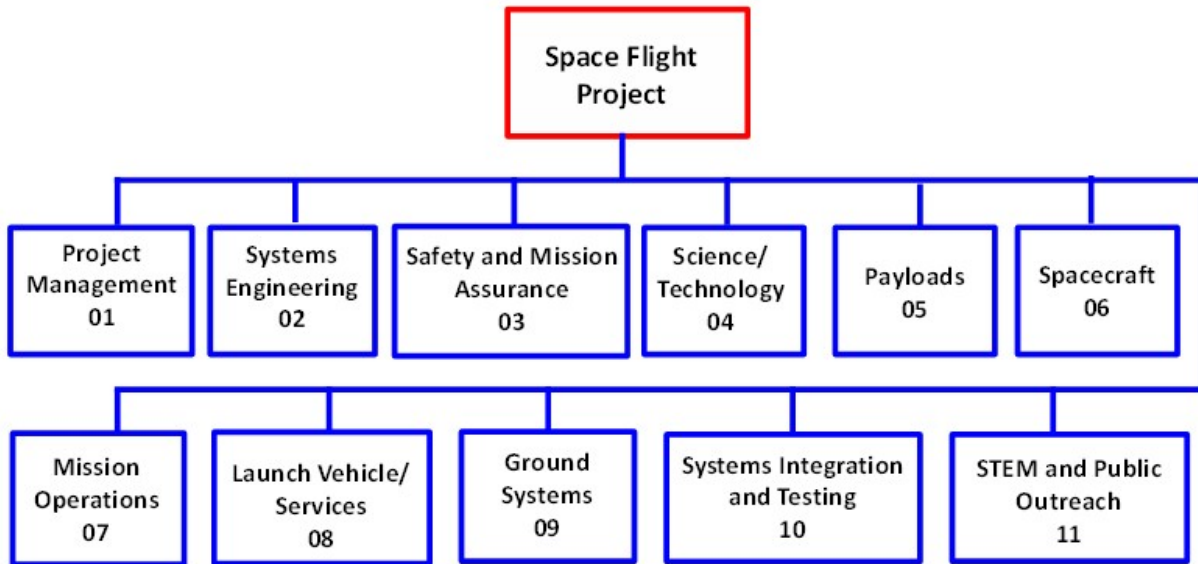

**Figure 3-4. Standard Level 2 WBS Elements for Space Flight Projects (“NASA Space Flight Program and Project Management Handbook,” Figure 4.10).**

3.5.3.2 The following best practices should be followed in developing the WBS:

- a. The Project/Task name is the WBS Tier 1 element.
- b. The title of each WBS Tier 2 element may be modified to facilitate Project/Task-unique titles, but the content of each needs to remain the same. If the linkage of the unique title to the standard title is not intuitive, the unique title is cross-referenced to the standard.
- c. If the set of standard WBS Tier 2 elements does not comprise an exhaustive set of WBS elements, additional WBS elements may be added horizontally (i.e., at Tier 2) as long as their content does not fit into the content of any existing standard WBS elements.
- d. For each standard WBS Tier 2 element, the subordinate (children) WBS elements at Tier 3 and lower will be defined by the Project/Task team.
- e. The standard WBS template in Figure 3-4 assumes a typical spacecraft flight development Project with relatively minor ground or mission operations elements. For major ground development activities, which are viewed as Projects unto themselves, the WBS may be modified appropriately. For example, the spacecraft element may be changed to reflect the major deliverable product (such as a facility) of a ground Project. The elements such as payload, launch vehicle/services, ground system(s), and mission operations (system) that are not applicable may be deleted.

### 3.5.3.3 The Space Flight Project Standard WBS Dictionary definitions are as follows:

- a. Element 1—Project Management: This element accounts for the business and administrative planning, organizing, directing, coordinating, analyzing, controlling, and approval processes used to accomplish overall Project objectives that are not associated with specific hardware or software elements. It includes Project internal reviews and life-cycle reviews (LCRs), as well as documentation and non-Project-owned facilities. It excludes costs associated with technical planning and management and costs associated with delivering specific engineering, hardware, and software products.
- b. Element 2—Systems Engineering: This element accounts for the technical and management efforts of directing and controlling an integrated engineering effort for the Project. It includes defining the Project space flight vehicle(s) and ground system; conducting trade studies; and performing integrated planning and control of the technical Project efforts of design engineering, software engineering, specialty engineering, system architecture development and integrated test planning, system requirements writing, configuration control, technical oversight, control and monitoring of the technical Project, and risk mitigation activities. Documentation products include requirements documents, the SEMP, Interface Control Documents (ICDs), and the master Verification and Validation (V&V) plan. This element excludes any design engineering costs.
- c. Element 3—Safety and Mission Assurance: This element accounts for the technical and management efforts of directing and controlling the SMA elements of the Project. It includes design, development, review, and verification of practices and procedures and mission success criteria intended to ensure that the delivered spacecraft, ground systems, mission operations, and payload(s) meet performance requirements and function for their intended lifetimes. These SMA requirements, practices, and procedures should be documented in the SMAP. This element also includes mishap contingency response and operations. This element excludes mission and product assurance efforts directed at partners and subcontractors other than a review/oversight function, as well as the direct costs of environmental testing.
- d. Element 4—Science/Technology: This element includes the managing, directing, and controlling of the science investigation aspects, as well as leading, managing, and performing the technology demonstration elements of the Project. The costs incurred to cover the PI, project scientist, science team members, and equivalent personnel for technology demonstrations are included. Specific responsibilities include defining the science or demonstration requirements; ensuring the integration of these requirements with the payloads, spacecraft, ground systems, and mission operations; providing the algorithms for data processing and analyses; and performing data analyses and archiving. This element excludes hardware and software for onboard science investigative instruments and payloads.
- e. Element 5—Payload(s): This element includes the equipment provided for special purposes in addition to the normal equipment (i.e., Ground Support Equipment (GSE)) integral to the spacecraft. This includes leading, managing, and implementing the hardware and software payloads that perform the scientific experimental and data-gathering functions placed on board the spacecraft, as well as the technology demonstration for the mission.
- f. Element 6—Spacecraft: The spacecraft serves as the platform for carrying payload(s), instrument(s), humans, and other mission-oriented equipment in space to the mission destination(s) to achieve the mission objectives. The spacecraft may be a single spacecraft or

multiple spacecraft/modules (i.e., cruise stage, orbiter, lander, or rover modules). Each spacecraft/module of the system includes the following subsystems, as appropriate: Crew; Power; Command and Data Handling (C&DH); Telecommunications; Mechanical; Thermal; Propulsion; Guidance, Navigation, and Control (GN&C); Wiring Harness; and Flight Software. This element also includes all design, development, production, assembly, test efforts, and associated GSE to deliver the completed system for integration with the launch vehicle and payload. This element does not include integration and test with payloads and other Project systems.

- g. Element 7—Mission Operations System: This element accounts for the management of the development and implementation of personnel, procedures, documentation, and training required to conduct mission operations. It includes tracking, commanding, receiving/processing telemetry, analyses of system status, trajectory analysis, orbit determination, maneuver analysis, target body orbit/ephemeris updates, and disposal of remaining end-of-mission resources. The same WBS structure is used for Phase E Mission Operation Systems but with inactive elements defined as “not applicable.” However, because of NASA cost reporting requirements, different accounts should be used for Phase E. This element does not include integration and test with the other Project systems.
- h. Element 8—Launch Vehicle/Services: This element accounts for the management and implementation of activities required to place the spacecraft directly into its operational environment or on a trajectory toward its intended target. This element includes launch vehicle, launch vehicle integration, launch operations, any other associated launch services (frequently includes an upper-stage propulsion system), and associated GSE. This element does not include the integration and test with the other Project systems.
- i. Element 9—Ground System(s): This element accounts for the complex of equipment, hardware, software, networks, and mission-unique facilities required to conduct mission operations of the spacecraft systems and payloads. The complex includes the computers, communications, operating systems, and networking equipment needed to interconnect and host the Mission Operations software. This element includes the design, development, implementation, integration, test, and associated support equipment of the ground system, including the hardware and software needed for processing, archiving, and distributing telemetry and radiometric data and for commanding the spacecraft. It also includes the use and maintenance of the Project test beds and Project-owned facilities. This element does not include integration and test with the other Project systems or the conducting of mission operations.
- j. Element 10—Systems Integration and Testing: This element includes the hardware, software, procedures, and Project-owned facilities required to perform the integration and testing of the Project’s systems, payloads, spacecraft, launch vehicle/services, and mission operations.
- k. Element 11—STEM and Public Outreach: This element provides for the STEM and Public Outreach responsibilities of NASA’s missions, Projects, and programs in alignment with NASA’s Strategic Plan for Education. This includes management and coordinated activities, formal education, informal education, public outreach, media support, and Web site development.

### **3.5.4 Work Breakdown Structure Template for Space Flight Systems Projects**

Table 3-3 provides a standard template for a WBS.

**Table 3-3. WBS Structure Template**

Project Title	
Elements	Lower Level Elements
<b>1.0 Project Management</b>	
1.1 Project Management, Administration, and Reporting	<ul style="list-style-type: none"> <li>• Project Management Plan and Performance Metric Development</li> <li>• Internal/External Project and Peer Review</li> </ul>
1.2 Business Management	<ul style="list-style-type: none"> <li>• PM Reviews, Performance Metrics, and Periodic Reporting</li> <li>• Cost Performance Reports</li> </ul>
1.3 Configuration and Data Management	<ul style="list-style-type: none"> <li>• Resource (Budget and Workforce) Management</li> <li>• Integrated Baseline Reviews (IBRs)</li> </ul>
1.4 Information Technology (IT)	<ul style="list-style-type: none"> <li>• System Development and Maintenance</li> <li>• Meeting and Review Support</li> </ul>
1.5 Integrated Scheduling Management	<ul style="list-style-type: none"> <li>• Project IT Requirements</li> <li>• IT Purchase and Implementation</li> <li>• IT Maintenance</li> <li>• IT Security Plan</li> </ul>
1.6 Earned Value Management (EVM)	<ul style="list-style-type: none"> <li>• Resource Loaded Schedule (RLS) Development</li> <li>• RLS Maintenance and Reporting</li> <li>• Meeting Support</li> <li>• Review Support</li> </ul>
1.7 Risk Management	<ul style="list-style-type: none"> <li>• EVM System Development</li> <li>• EVM Maintenance</li> <li>• EVM Assessment and Reporting</li> <li>• Meeting and Review Support</li> </ul>
1.8 Cost Estimation and Assessment	<ul style="list-style-type: none"> <li>• Risk Management System Development</li> <li>• Continuous Risk Management (CRM) Review and Reporting</li> </ul>
1.9 External Relationships	<ul style="list-style-type: none"> <li>• Life-Cycle Cost (LCC) Estimating</li> <li>• Independent Government Cost Estimating (for contracts)</li> <li>• Contractor Management</li> <li>• Other NASA Centers, Commercial Partners, and Government Agencies</li> </ul>
<b>2.0 System Engineering and Integration (SE&amp;I)</b>	
2.1 Systems Engineering Management	
2.2 Integrated Models and Simulations	
2.3 Open Architecture	
2.4 Software Engineering	
2.5 Mission and System Analysis	
2.6 Integrated Logistics Support (ILS)	
2.7 Systems Test, Verification, Validation, and Certification Planning	
2.8 Human Engineering	
2.9 Specialty Engineering	<ul style="list-style-type: none"> <li>• Electromagnetic Compatibility</li> <li>• Natural and Induced Environments</li> <li>• Electrical, Electronic, and Electromechanical (EEE) Parts Engineering</li> </ul>
2.10 Project Integration	
2.11 Requirements Definition and Management	
<b>3.0 Safety and Mission Assurance (SMA)</b>	
3.1 SMA Management and Administration	
3.2 System Safety	
3.3 Industrial, Environmental, Processing Site, Launch Site, and Range Safety	
3.4 EEE and Mechanical Parts Control	
3.5 Materials and Processes	
3.6 Reliability and Probabilistic Risk Assessment	
3.7 Hardware Quality Assurance	
3.8 Software Safety and Assurance	
<b>4.0 Science/Technology Development</b>	
4.1 Individual Science/Technology Development Project WBS	
4.2 Individual Science/Technology Development Project WBS	
<b>5.0 Payload(s) Product Breakdown Structure (PBS)</b>	
5.1 Avionics Subsystem	<ul style="list-style-type: none"> <li>• Flight Software</li> <li>• C&amp;DH</li> <li>• Communication and Tracking (C&amp;T)</li> <li>• Displays and Controls</li> </ul>
5.2 Electrical Power Subsystem	
5.3 Mechanical Subsystem	
5.4 Thermal Control Subsystems	
5.5 Structural Subsystem	
5.6 Propulsion Subsystem	
5.7 GN&C Subsystem	
5.8 Government Furnished Equipment	

**Table 3-3. WBS Structure Template**

Project Title	
Elements	Lower Level Elements
5.9 Payload Production, Assembly, and Integration	
<b>6.0 Spacecraft Product Breakdown Structure (PBS)</b>	
6.1 Avionics Subsystem	<ul style="list-style-type: none"> <li>• Flight Software</li> <li>• C&amp;DH</li> </ul>
6.2 Electrical Power Subsystem	<ul style="list-style-type: none"> <li>• C&amp;T</li> <li>• Displays and Controls</li> </ul>
6.3 Mechanical Subsystem	
6.4 Thermal Control Subsystem	
6.5 Structural Subsystem	
6.6 Propulsion Subsystem	
6.7 Suits, Extravehicular Activity (EVA) and Survival Crew Equipment Support Systems	
6.8 Environmental Control and Life Support Subsystem (ECLSS)	
6.9 Crew Health and Habitation Accommodations Subsystem	
6.10 Pyrotechnics Subsystem	
6.11 Landing and Recovery Systems	
6.12 GN&C Subsystem	
6.13 Government Furnished Equipment	
6.14 Spacecraft Production, Assembly, and Integration	
<b>7.0 Mission Operations</b>	
7.1 Operations Management and Administration	
7.2 Operational Analyses Supporting Design	
7.3 Ground Operations	<ul style="list-style-type: none"> <li>• Requirements Development Support</li> <li>• Ground Operations Support</li> </ul>
7.4 Flight Operations	<ul style="list-style-type: none"> <li>• Flight Operations Preparation</li> <li>• Flight Operations Execution</li> </ul>
7.5 Range Safety	
7.6 Training	<ul style="list-style-type: none"> <li>• Training Requirements Development Support</li> <li>• Training Support</li> </ul>
<b>8.0 Launch Vehicle/Services</b>	
8.1 Launch Vehicle/Services Management and Administration	
8.2 Launch Vehicle Processing and Support Activities	
8.3 Launch Vehicle Procurement	
<b>9.0 Ground System(s)</b>	
9.1 Ground System(s) Management and Administration	
9.2 Ground Facility	<ul style="list-style-type: none"> <li>• Facility System Requirements Development</li> <li>• GSE Development</li> <li>• Capital Improvement</li> </ul>
9.3 Training	<ul style="list-style-type: none"> <li>• Minor Construction of Facilities</li> <li>• Construction of Facilities (CoF)</li> <li>• Facility Operation Support</li> </ul>
9.4 Storage	<ul style="list-style-type: none"> <li>• Training System Requirements Development</li> <li>• Training System Equipment Development</li> <li>• Storage Facility Requirements Development</li> <li>• Storage Facility Operation</li> <li>• Storage Facility Preparation</li> </ul>
<b>10.0 Systems Integration and Testing</b>	
10.1 Systems Integration and Testing Management and Administration	
10.2 Integration, Test, Verification, Validation, and Certification Execution	
10.3 Ground Test	
10.4 Flight Test	<ul style="list-style-type: none"> <li>• Flight Test Requirements Development</li> <li>• Flight Test Article Design and Production</li> <li>• Test Article GSE</li> <li>• Flight Test Support</li> </ul>
<b>11.0 STEM and Public Outreach</b>	
11.1 STEM and Public Outreach Management and Administration	
11.2 Outreach Activities	<ul style="list-style-type: none"> <li>• Requirements Development</li> <li>• Outreach Activity Support</li> <li>• Development or Purchase of Outreach Materials</li> </ul>

### 3.5.5 Additional Resources

More guidance for developing WBSs can be found in the “NASA Work Breakdown Structure Handbook” <http://ntrs.nasa.gov>.

## **3.6 Develop Acquisition (Make/Buy) Strategy**

**3.6.1 Purpose.** This section provides guidance to the Project/Task team for developing the acquisition strategy for the system/product which the Project/Task is chartered to develop and deliver for the customer.

### **3.6.2 Rationale**

- a. The PM should determine the approach for acquiring system hardware and/or software optimized across the spectrum of “buy,” contracting with external suppliers to “make,” utilizing internal GRC staff and other resources, or an appropriate combination of the two.
- b. This section relates to Numbers 36 through 49 (requirements Table 1-4, “Project Management Planning and Control Products,” Items 1 to 5) in the Compliance Matrix (Appendix C).

### **3.6.3 Acquisition Strategy Development Process**

3.6.3.1 The PM, with support from the CE, LSE, CAMs, the Procurement Office, and Office of the General Counsel, should meet to identify, evaluate, and select make/buy strategy options.

- a. “Buy” options need not be limited to external industry contractors procured via new prime contract solicitations. “Make” providers could also be external partners such as universities or national laboratories managed by other federal agencies. External participants may be incorporated into the acquisition strategy when they can offer particular expertise, or if the needed skill is not available at GRC, or as otherwise directed by the Project customer.
- b. “Make” options should be coordinated with GRC’s Manufacturing Division, which maintains a right of first refusal for the manufacturing of SFS hardware.

3.6.3.2 For specific procurement instructions, see GLPR 5100.1, Procurement. GLPR 5100.1 provides specific information about the GRC purchasing process. This GLPR 7120.5.10 explains the overall process.

3.6.3.3 The PM, with the Chief Financial Officer (CFO), determines if purchase acquisitions meet capitalized equipment criteria. If acquisitions meet criteria, the PM completes NF 1739, with capital assets, unique WBSs, and asset indicator types identified.

3.6.3.4 Once the proposed acquisition strategy is finalized, it should be documented in the Project/Task Scope Summary document for review and approval at the PRB and should be subsequently documented in greater detail in the PP.

## **3.7 Define and Estimate the Work**

**3.7.1 Purpose.** The purpose of this section is to describe the inputs, outputs, activities, and roles for the Project/Task team to perform to define and estimate the work required to execute the Project/Task.

### **3.7.2 Rationale**

3.7.2.1 Carefully decomposing and estimating all the work necessary to deliver the Project/Task system/hardware/software is critical to providing a sound and defensible Basis of Estimate (BOE) to underpin the development of the budget and schedule during subsequent planning.

3.7.2.2 This section relates to Numbers 40 through 49 (NPR 7120.5 requirement Table 1-4, “Project Management, Planning, and Control Products,” Item 44, including 44.a through j), in the Compliance Matrix (Appendix C).

### 3.7.3 Define and Estimate the Work Process Description

As shown in Figure 3-5, the PM should work closely with the CAMs to decompose the WBS elements defined in Section 3.5 down to the point where individual work tasks can be defined and the resources and time durations required to execute them can be estimated. Each step in this process is summarized as follows.

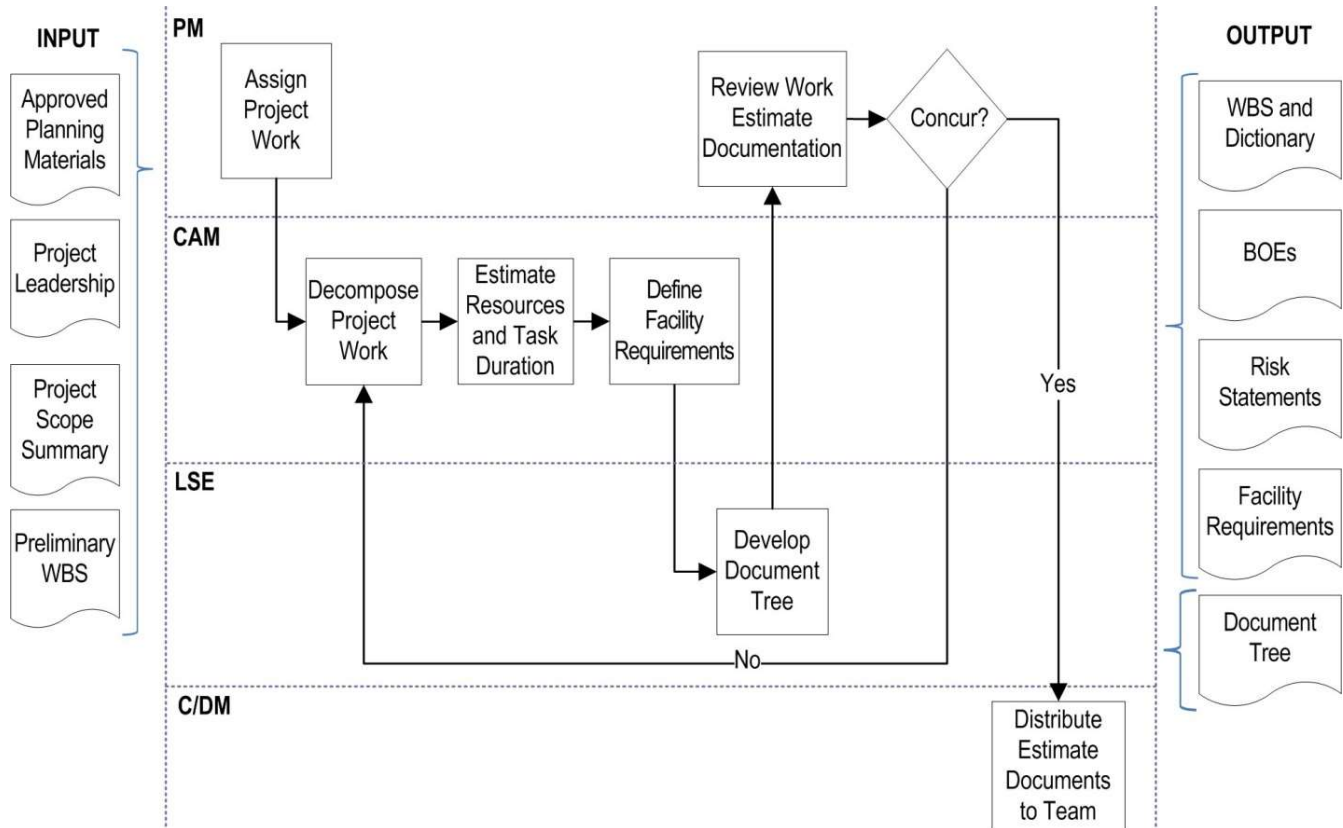

Figure 3-5. Process to Define and Estimate the Project/Task Work

### 3.7.4 Assign Project Work

The PM, with the CE and CSO, assigns the WBS elements to the CAMs. The CAMs should work with the WBS dictionary developed during initial Project/Task scoping per Section 3.3 as a starting point for further decomposition of the work.

### 3.7.5 Decompose Project Work

The CAMs should decompose their WBS elements into lower-level work packages, and further decompose each work package into discrete tasks. These task definitions should be captured in suitable planning tool, such as the GRC Cost Model or another BOE template of the CAMs choosing, selected in consultation with the PM, CE, and IM (for Gold Class Projects).

- a. The GRC Cost Model has been developed for use during the project preliminary planning process.
- b. The GRC Cost Model can be found on the OCFO website:  
<https://nasa.sharepoint.com/sites/grc-ocfo/SitePages/Estimated-Price-Report.aspx>
  - (1) CAMs that are responsible for WBS elements that produce systems/subsystem hardware/software deliverables should define a Product Breakdown Structure (PBS) within their assigned element. The PBS is analogous to the WBS in that it captures the logical product breakdown from higher-tier deliverables into lower-tier ones down to the point at which they can be accurately estimated. Figure 3-6 shows a typical aerospace system product breakdown definition:



**Figure 3-6. Typical Aerospace System Product Breakdown Definition**

- (2) The PM should ensure that external partnerships responsibilities and deliverables are identified in the WBS dictionary.
- (3) CAMs, with the CE and Risk manager, should identify and document any candidate risks associated with their plan. All candidate risks associated with the plan will be provided to the CSO for review by the PM, such as a presentation to the Project/Task Risk Management Board (RMB), PCB, or equivalent.

### 3.7.6 Estimate Work Resources and Duration

3.7.6.1 Once the work packages and lowest tier task definitions have been defined, the resources required to execute each task, and deliver each product, should be estimated, and the BOE for each resource estimate should be documented in the Cost Model. The following parameters are typically estimated in this process:

- a. CS labor by skill/discipline, usually identified by GRC organization code.
- b. CS service labor in direct labor hours
- c. PBC labor by skill/discipline, usually identified by contract name. (See Section 3.16, for the PBC contracts.).
- d. PBC labor in direct labor hours
- e. Procurement costs in dollars. Any potential long-lead procurements should be identified.
- f. CS costs in dollars, typically estimated bottoms-up by estimating number of planned trips, number of travelers, and worst-case cost per trip. The PM should provide the CAMs with standard assumptions for estimating travel costs.
- g. Discrete work task duration (time from start to finish) in direct work hours or days, as appropriate.

3.7.6.2 Estimates can be developed using one or more of the following typical bases:

- a. Management or engineering experience

- b. Past Project/Task historical experience
- c. Vendor quote or catalog cut sheet.
- d. Parametric estimating relationship

3.7.6.3 The fully populated Cost Model or other documentation of the work tasks and resource estimates will then be used to develop the Project/Task RLS per Section 3.8.

*Note: When estimating work task schedule-related parameters, it is better practice at this stage in the process to estimate the task duration rather than discrete start and end dates because these dates should be expected to vary once all the tasks are transferred into MS Project, or a similar scheduling software tool, and the predecessor-successor logic is linked between the tasks.*

3.7.6.4 CAMs should obtain concurrence from the DLEs or their supervising managers that the WBS element definition and resource estimates are appropriate and consistent with the available workforce in the required core competency organizations.

### **3.7.7 Define Facility Requirements**

The CAMs:

- a. With the CE, Chief Technologist (CT), and appropriate DLEs/supervising managers, should estimate test or manufacturing facility utilization needed for the Project/Task, to include the specific test, the facility name, setup time (hours), test run time (hours), and breakdown time (hours), plus a preliminary identification of any facility modifications that might be required.
- b. Should consult with representatives from Code F to complete a preliminary business case analysis for any infrastructure or other real property investments consistent with NPD 8820.2 and NPR 8820.2.

### **3.7.8 Develop Document Tree**

At this point in the planning flow, the LSE should develop a preliminary draft of the Project/Task document tree referencing the BOE or Cost Model and tailoring tools for document deliverables.

### **3.7.9 Review Work Estimate Documentation**

The PM, with the CE, CSO, LSE and CAMs, should review:

- a. Each WBS and PBS element decomposition in the WBS dictionary, along with the associated work task resource and duration estimates captured in the Cost Model or BOE tool for completeness. Any changes should be addressed prior to pricing and scheduling the work in Section 3.8.
- b. The Risk Information Sheets (RISs) for understanding and completeness, prior to formally accepting them and putting them under configuration control.

### **3.7.10 Distribute Estimate Documentation to Team**

If the PM, CE, CT, and CSO concur with the WBS dictionary, BOE, candidate RISs, long-lead procurement list, and facilities requirements, these items should then be put under configuration control per the Project/Task CM process and distributed to the full Project/Task team for future use.

## **3.8 Develop Budget and Schedule**

**3.8.1 Purpose.** The purpose of this section is to define the process to be used by the Project/Task team to develop the budget and schedule associated with the work defined in Section 3.7. This process may be used several times over the life cycle of the Project/Task.

### **3.8.2 Rationale**

- a. Accurate cost and schedule estimates are critical to successful project execution, and these estimates must have a sound, defensible, and documented basis. The PM should lead the team in performance of this process to develop the budget and schedule plan (and supporting artifacts) that can become the performance baseline at the appropriate point in the Project/Task life cycle, as per Section 3.8.
- b. This section provides procedures that will enable requirement 2.5.a of GLPR 7120.5.10 to be complied with. This section relates to Numbers 44, 47, 78 through 80, and 91 through 95 (NPR 7120.5 requirements, “Project Management, Planning, and Control Products,” Table 1-4; “Project Plan Control Plans Maturity Matrix,” Table 1-5, Items 5.d and 5.g; and requirements 2.2.8, 2.2.8.1, 2.2.8.2, 2.4.3, and 2.4.4.1) in the Compliance Matrix for the Project (Appendix C).

### **3.8.3 Budget and Schedule Development Process**

The PM should orchestrate the steps shown in Figure 3-7 and as described in the following paragraphs. This activity will establish the Project/Task Integrated Master Schedule (IMS) that is resource loaded, a RLS, and will establish the Project/Task budget plan. This is a bottoms-up approach to developing the Project/Task schedule and budget, which are then checked against the milestones and budget marks developed during initial project scoping per Section 3.7 for comparison.

*Figure 3-7 starts on next page.*

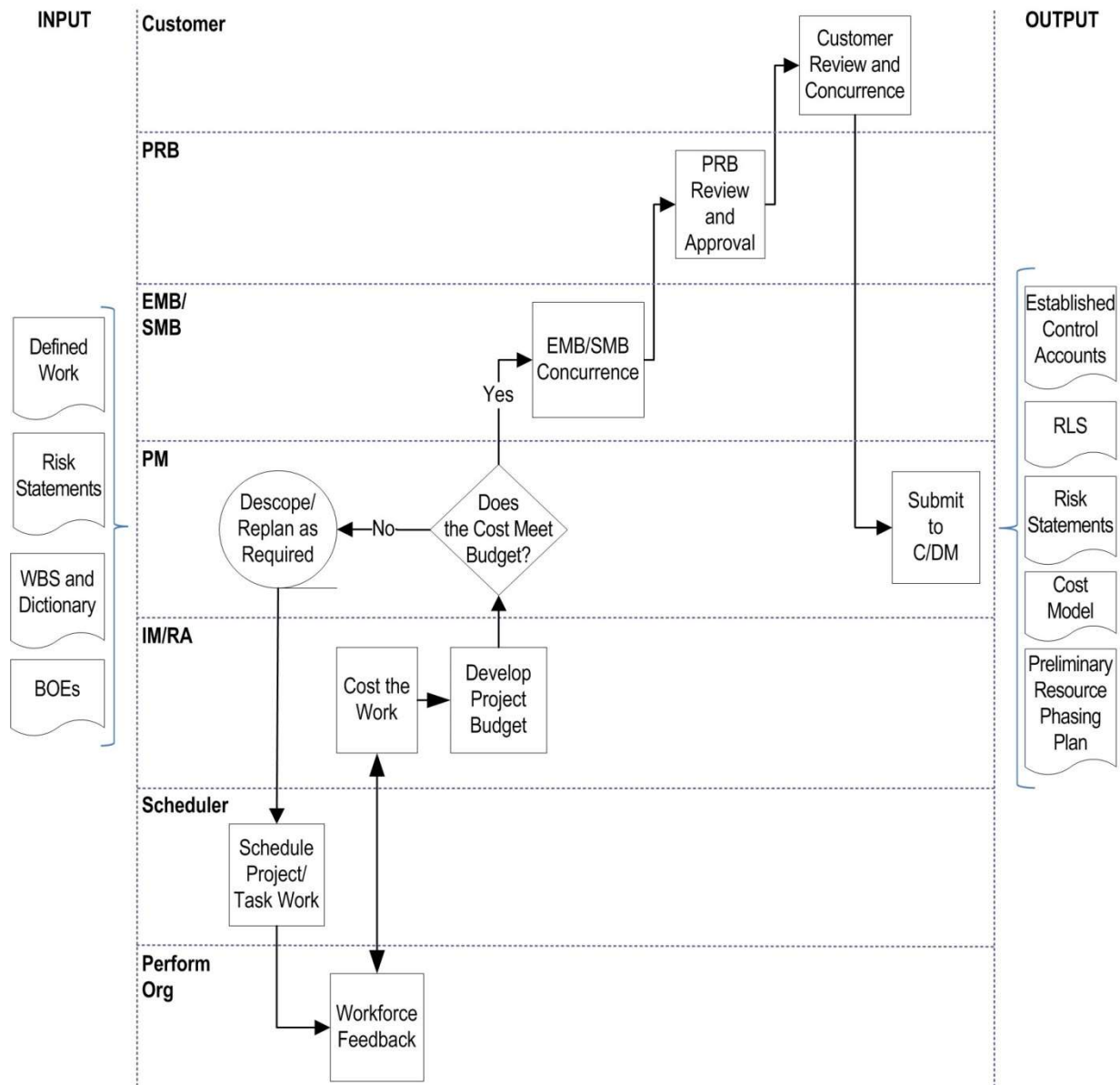

**Figure 3-7. Schedule and Price the Work Procedure**

### 3.8.4 Schedule Project/Task Work

3.8.4.1 All Projects/Tasks should develop cost estimates and planned schedules for the work to be performed in the current and following life-cycle phases. The Cost Model BOEs developed in Section 3.7 serve as a key input shown as Defined Work at the left side of Figure 3-7.

3.8.4.2 The Scheduler develops the RLS for the Project using the BOEs or Cost Model filled out by the CAMs in Section 3.7 and the milestones listed in the Project Scope Summary and/or the PP. As the Scheduler lays the individual tasks into the scheduling tool software, predecessor-successor network logic linkages should be established, working closely with the CE, LSE, and CAMs as needed to understand the overall flow of the work. Once all the work tasks, resource estimates, durations, and network logic have been loaded into the scheduling tool software, the Project/Task milestones should then be predicted from the RLS and compared with the customer expectations that were captured into the Project Scope Summary (Appendix D) per Section 3.4.

CAMS are required to develop lower-level task plans/schedules for their areas based on meeting higher level project milestones, and these inputs will be provided to the Scheduler to integrate into an overall schedule. The CAMs also need to provide continuous updates per PM guidance. These lower-level schedule inputs from the CAMs are critical to developing and maintaining a useful RLS.

3.8.4.3 The RLS must be developed from the scheduling tool software standard template found on the ePMS Web site, unless otherwise directed from the Program Office, MD, or lead center. The RLSs should be developed in accordance with the NASA/SP-2010-3403, NASA Schedule Management Handbook.

### 3.8.5 Funded Schedule Margin

3.8.5.1 All projects should include funded schedule margin along the critical path of the IMS. Guidance for the recommended funded schedule reserve margin over the lifecycle of the project is as follows:

Phase	Recommended Project Held Margin
Formulation through subsystem development	1 month per year
System I&T through delivery to launch site (or storage)	2 months per year
Delivery for launch processing through Launch	1 month per year
Launch through mission completion (Phase E), if applicable	1 month per year

3.8.5.2 Project management should work with their project scheduler to ensure that funded schedule margin is incorporated in the IMS. Additionally, projects should validate their funded schedule margin by conducting an assessment of implementation risk. Typically, this is done through a Schedule Risk Analysis (SRA). Projects should contact the GRC Program Planning & Control Office (PPCO) for guidance and support to conduct an SRA.

3.8.5.3 For more in depth information concerning Schedule Management, consult NASA/SP—2010-3403, “NASA Schedule Management Handbook” (<http://ntrs.nasa.gov>).

### 3.8.6 Workforce Feedback

Once a preliminary RLS has been developed, the PM, CE, and CSO should engage GRC line organization management to review the plans with the CAMs to identify any need for CS team staff to be supplemented by PBC staff. This support can then be acquired via the process at Section 3.16.

### 3.8.7 Cost the Work

3.8.7.1 The IM (for Gold Class Projects), or the RA for other Projects/Tasks, should work with the Scheduler to ensure that the work estimated with the GRC Cost Model agrees with the work reflected in the RLS. The Scheduler should run the GRC RLS-to-Cost Model translator to perform this verification: <https://nasa.sharepoint.com/sites/grc-ocfo/SitePages/Scheduling->

[Resources.aspx GRC RLS-to-Cost Model Translator: https://nasa.sharepoint.com/sites/grc-ocfo/SitePages/Scheduling-Resources.aspx](https://nasa.sharepoint.com/sites/grc-ocfo/SitePages/Scheduling-Resources.aspx) (About halfway down this site under “GRC Project Add-in”)

3.8.7.2 The IM (or the PM if no IM is assigned), with the Scheduler and the RA, should review the resulting costs and document existing resource conflicts and/or budget exceedances for future resolution in the next planning iteration, and/or in consultation with GRC management.

### **3.8.8 Develop Project Budget**

The RA should then develop a preliminary budget phasing plan using the RLS and Cost Model information as input, and following the process described in Section 3.8.

- a. Evaluate the Budget Estimate. The PM should check to see if the RLS and Cost Model predict a total life cycle cost, and an annual budget phasing, that meet the customer’s budget marks provided during project scoping per Section 3.8. If the budget marks are not met, the PM, CE, LSE, and CAMs should identify conflicts that are driving the cost/budget exceedances.
- b. The PM, CE, LSE, CSO, and PI (for science-related Projects/Tasks) should define a plan to resolve identified conflicts, and present and review it with GRC management for awareness and issue resolution. Relevant portions of the workflows in Figure 3-5 and Figure 3-7 should be repeated as necessary to generate a new plan to resolve the conflicts. Preliminary risks may also be identified as needed to document any descoping needed to bring the budget and/or schedule in line with the customer’s marks.

### **3.8.9 GRC Management Authority Review and Approval**

The PM should then present the Project/Task budget, schedule, and risk details to the Safety and Mission Assurance Management Board (SMB), EMB, and PRB for concurrence/approval in sequence, as shown in Figure 3-7, before submitting the budget and schedule to the external customer.

### **3.8.10 Additional Resources**

Additional guidance can be found in the NASA Schedule Management Handbook NASA/SP—2010-3403, and NASA Cost Estimating Handbook (<http://ntrs.nasa.gov>).

## **3.9 Develop Agreements**

### **3.9.1 Purpose**

The purpose of this section is to document the processes for developing internal agreements needed for obtaining resources from GRC performing organizations who provide the labor and other resources to perform the Project/Task work, as well as external agreements with organizations outside GRC for Projects/Tasks needed to either provide funds to GRC for Task work in support of other Level III lead organizations, or to formalize support that GRC is requesting from non-NASA external organizations.

### **3.9.2 Rationale**

It is considered a best practice to have a formal document between any outside entity and GRC describing the technical work, budget, and schedule. This best practice is recommended to document the agreement with the GRC internal performing organizations as to the personnel

assigned to do the work. This section is for GRC standard operating practice and does not satisfy any requirements in the Compliance Matrix (Appendix C).

### **3.9.3 Agreement Development Steps**

#### **3.9.3.1 Develop Internal Agreements**

- a. The Project RA should load the FTE, WYE, and funding requirements into the Project/Task Project Requirements Document (PRD) GRC resource database when open for entry.
- b. The Portfolio Integration Lead, in coordination with the RA and PM, should request that the OCFO civil servant (CS) budget analyst open lower-level financial WBS codes for labor, purchasing, and travel charges per the preliminary budget phasing plan developed per Section 3.8.
- c. Other documents or databases may be employed by the PM to document agreements reached with performing organization line management regarding the provision of CS staff or other resources to the Project/Task team.

#### **3.9.3.2 Develop External Customer Agreements**

- a. The PM should lead the establishment of all Project/Task external agreements. Negotiations should be initiated by the PM early in the planning phase to prevent any potential delays in obtaining funding at ATP.
- b. An External Support Agreement (ESA) (template in Appendix G) can be used as a concise document to authorize funds transfer between GRC and an external organization. This form can be used for either (or both) of the following purposes:
  - (1) For a Level III Project led by another organization to provide funding to GRC for performance of a supporting Task.
  - (2) For GRC to provide funding to an external organization, such as another federal agency, to perform work for the GRC-led Project or Task.

*Note: if the ESA is insufficient to provide all the desired tasking information, then a Task Plan may be utilized in its place. See Section 3.4.*

### **3.10 Develop FA, Project Plan, and Task Plan**

#### **3.10.1 Purpose**

The purpose of this section is to describe the expectations and process for developing the FA, PP, and Task Plan.

#### **3.10.2 Rationale**

- a. FAs and PPs apply to Level III Projects that GRC leads for the Agency or a Program Office. Figure P illustrates the differences between Projects and Tasks and provides definitions.
- b. This section provides procedures that will enable requirement 2.6.1a of GLPR 7120.5.10 to be complied with, and it relates to Numbers 36 and 37 (NPR 7120.5 requirements Table 1-4, “Project Management, Planning, and Control Products,” Items 1 and 2) in the Compliance Matrix for the Project (Appendix C).

- c. Subordinate plans, collectively called control plans, are required by the Compliance Matrix (Numbers 51 through 77, Table 1-5 of NPR 7120.5) for Level III Projects (see Figure P) unless they are determined to be not applicable during the tailoring process. Control plans implement requirements in NPDs and NPRs that affect Project planning.

### 3.10.3 Descriptions

- a. The FA represents the Project's or single-Project Program's response to the FAD. It establishes technical and acquisition work that needs to be conducted during Formulation and defines the schedule and funding requirements during Phase A and Phase B for that work.
- b. The PP defines, at a high level, the scope of the Project, the implementation approach, the environment within which the Project operates, and the baseline commitments of the Program and Project. The PP is consistent with the Program Plan and should be written early in the life cycle of the Project to cover all phases, even if an FA has previously been written and approved.
- c. Task Plans are tailored-down versions of PPs, shorter in length and description, with a concentrated focus on key aspects of a Task at GRC. Task Plans are utilized on Level IV Tasks.
- d. For both projects and tasks, describe the DA delegation path within the plan. This delegation may be from the MDAA to the center director to the SFS director for projects or to a designated management official in accordance with Section 2.4, Delegation of Management Authority and Table 2-2, GRC Governance/Approval Authority Guidance. For tasks, the DA delegation may be given to the appropriate division or branch chief or project manager.

### 3.10.4 Formulation Agreement (FA)

The FA:

- a. Focuses on the Project or single-Project program activities necessary to accurately characterize the complexity and scope of the Project or single-Project program; to increase understanding of requirements; and to identify and mitigate high technical, acquisition, safety, cost, and schedule risks. It identifies and prioritizes the Phase A and Phase B technical and acquisition work that will have the most value and enables the Project or single-Project program to develop high-fidelity cost and schedule range estimates at KDP B and high-fidelity cost and schedule commitments at KDP C.
- b. Serves as a tool for communicating and negotiating the Project's or single-Project program's Formulation plans and resource allocations with the program and MD. It allows for differences in approach for competed and assigned missions. Variances with product maturities as documented in Appendix H are identified with supporting rationale in the FA. The approved FA serves as authorization for these variances. The FA is approved and signed at KDP A and is updated and resubmitted for signature at KDP B. The FA for KDP A includes detailed Phase A information and preliminary Phase B information. The FA for KDP B identifies the progress made during Phase A and updates and details Phase B. The FA should be tailored in relation to the size of the project following the guidance in Section 2.6.

*Note: See Appendix E for more information concerning the Project FA.*

### 3.10.5 Project Plan (PP)

- a. See Appendix F for complete guidance in using the PP template to produce a PP. The PP should be tailored in relation to the size of the Project following the guidance in Section 2.6.
- b. Control plans are optional for GRC Level IV Tasks. Control plans may be incorporated into major control documents like the PP (see Table 3-), SEMP, or SMAP. The tailoring tools described in Section 2.6 provide guidance for combining control plans and the fidelity of the plans. Certain control plans—the SMAP, Risk Management Plan, SEMP, and Software Management Plan—are typically stand-alone plans with summaries and references provided in the PP. The remaining control plans can either be incorporated into the PP or developed as separate stand-alone documents referenced in the appropriate part of the PP. In the case of the latter, the PP contains a summary of and reference to the stand-alone document. The approval authority for the stand-alone control plan is the PM.
- c. Detailed descriptions of each control plan that can pertain to a Project are provided in Appendix F, the PP template. A complete list of control plans is shown in Appendix C, Numbers 51 to 79, Table 1-5, Project Plan Control Plans Maturity Matrix.

### 3.10.6 Task Plan

A Task Plan is a PP that is tailored down to meet a reduced list of contents. It will typically be used when more space is needed than is available in the ESA template (see Appendix G). See Table 3-5 for guidance pertaining to the typical minimum content of a Task Plan.

**Table 3-4. Typical Control Plans Described in a Project Plan\***

1. Technical, Schedule, and Cost Control Plan
2. Safety and Mission Assurance Plan (SMAP)
3. Risk Management Plan
4. Acquisition Plan
5. Technology Development Plan
6. Systems Engineering Management Plan (SEMP)
7. Systems Security Plan
8. Software Management Plan
9. Verification and Validation (V&V) Plan
10. Review Plan
11. Mission Operations Plan
12. NEPAN EPA Compliance Documentation
13. Integrated Logistics Support (ILS) Plan
14. Science Data Management Plan
15. Integration Plan
16. Configuration Management (CM) Plan
17. Security Plan
18. Project Protection Plan
19. Technology Transfer Control Plan
20. Knowledge Management Plan
21. Human Rating Certification Package
22. Planetary Protection Plan
23. Nuclear Safety Launch Approval Plan
24. Range Flight Safety Risk Management Process Documentation
25. Communications Plan
26. Quality Assurance Surveillance Plan
27. Orbital Collision Avoidance Plan
28. Human Systems Integration Plan

\*Numbers correspond to the item numbers in the Compliance Matrix (Appendix C), "Project Control Plans Maturity Matrix," Table 1-5.

**Table 3-4. Typical Content of Task Plan**

1.0	Project/Task Overview
2.0	Technical Approach
3.0	Requirements and Performance
4.0	Management Approach
5.0	Resource Requirements
6.0	Schedule
7.0	Safety and Risk Management
Appendices	

### **3.10.7 Project/Task Execution**

A general explanation of Project/Task execution typically performed during the Implementation phase is provided in the “NASA Space Flight Program and Project Management Handbook,” Sections 4.4 through 4.4.7 (Phase C through Phase E).

## **3.11 Establish Technical, Budget, and Schedule Baselines**

### **3.11.1 Purpose**

The purpose of this section is to describe the process to be used to establish technical, budget, and schedule performance baselines, and supporting artifacts (e.g., documents and electronic files) that provide evidence of the existence of the baseline.

### **3.11.2 Rationale**

- a. Performance baselines set the plan for expenditure of resources and completion of tasks that constitute the commitment between the PM and the customer. They are used to track the progress of the Project/Task over its life cycle. Monitoring the trends of actual budget and schedule performance against the baseline plan is a measure of the health of the Project/Task. If variance analysis during periodic reporting shows that the budget and/or schedule performance is drifting off the plan, corrective actions can be taken to prevent significant issues such as cost overruns or schedule delays.
- b. This section provides procedures that will enable requirement 2.5b of GLPR 7120.5.10 to be complied with. This section relates to Numbers 82, 89, and 91 (NPR 7120.5 requirements 2.3.1, 2.4.1.3, and 2.4.2) in the Compliance Matrix for the Project (Appendix C).

### **3.11.3 Process for Establishing Technical, Budget, and Schedule Baselines**

#### **3.11.3.1 Technical Baseline**

- a. The LSE should:
  - (1) Develop the requirements baseline to ensure that requirements from all stakeholders are captured and understood. A simple spreadsheet can be used for a Task or small Projects. Larger Tasks and Projects may require the use of requirement management tools or model-based systems engineering tools. The LSE should work with the system engineering DLE to assess the needs of the Project/Task to settle on an appropriate tool and approach, for recommendation to the CE and PM for concurrence.
  - (2) In consultation with the PM, CE, CSO, and PI (for science-related Projects/Tasks), lead the decomposition of requirements starting from the top-level needs, goals, and objectives captured in the Project Scope Summary and other information provided by

higher tier programmatic authorities, such as a higher-tier System Requirements Document (SRD), or equivalent.

- b. Proposed requirements should be carefully reviewed by the Project/Task leadership before they are agreed to. A formal process of requirements review and impact assessment should be implemented by the PM using the PCB process provided in Section 3.21, or equivalent.

### **3.11.3.2 Budget Baseline**

- a. The PM, in consultation with the higher tier programmatic customer and the GRC management authority, should determine when the preliminary budget plan developed per Section 3.8 is ready to be put under configuration control. This will constitute the establishment of the formal budget baseline.
- b. The budget baseline should be established as follows:
  - (1) Develop the Project/Task funding requirements by fiscal year using the preliminary phasing plan developed per Section 3.4. Define the required New Obligation Authority (NOA) in real-year dollars for all years—prior, current, and remaining. The funding requirements should be broken down via the WBS and include funding for all cost elements required by the Agency’s full-cost accounting procedures.
  - (2) Develop the Project’s FTE and WYE workforce requirements by fiscal year, consistent with the Project/Task phasing plan and WBS. Include the actual full-cost CS and support service contractor (SSC) workforce.
  - (3) Document key assumptions and risks associated with establishing the budget baseline.

### **3.11.3.3 Schedule Baseline**

- a. The PM, in consultation with the higher tier programmatic customer and the GRC management authority, should determine when the preliminary schedule developed per Section 3.8 is ready to be put under configuration control. This will constitute the establishment of the formal schedule baseline.
- b. The schedule baseline should be a set of key Project/Task milestones extracted from the RLS developed per Section 3.8, to which both the PM and the customer agree constitute the milestones by which acceptable Project/Task progress will be measured. Once the baseline is “struck,” the milestones are put under configuration control. Schedule progress is then tracked against these baselined milestones during periodic reporting.

*Note: There is a difference between baselining the schedule milestones agreed to with the customer versus putting the entire underlying RLS file under formal configuration control. The PM should exercise management discretion in only putting those artifacts under configuration control that will be expected to seldom change. The RLS file will be expected to be much more dynamic, and thus a lower level of control would be warranted on the actual RLS the scheduling tool software electronic file.*

## **3.12 Develop Independent Cost and Schedule Assessments**

### **3.12.1 Purpose**

The purpose of this section is to provide background information on, and a procedure for, developing independent cost and schedule assessments for a Project/Task. This same process is followed for projects requesting an advocacy estimate for any reason.

### **3.12.2 Rationale**

- a. Developing independent cost and schedule estimates can serve several beneficial purposes, such as to provide another perspective and method of estimation that the Project/Task team may not have considered, or to provide a valuable independent check and validation on the Project/Task teams budget and schedule plans prior to baselining them. They can also provide the customer with added confidence that the Project/Task team is producing accurate budget and schedule estimates and analysis in their day-to-day operations.
- b. This section relates to Number 20 (NPR 7120.5 requirement 2.2.6) in the Compliance Matrix for the Project (Appendix C).

### **3.12.3 Independent Cost and Schedule Assessments Procedure**

#### **3.12.3.1 Background Information**

- a. Independent cost and schedule assessments are usually performed to support milestone reviews as part of the Project review process (see NPR 7123.1, Appendix G). However, GRC Projects may request an independent cost and/or schedule assessment at any point in their life cycle from the GRC PPCO, Code BC.
- b. The “NASA Space Flight Program and Project Management Handbook” for NPR 7120.5 contains guidance for Project technical activities and products by phase, including requirements for independent cost and schedule estimates or assessments. At any point, a convening authority can request an Independent Cost Assessment (ICA) and/or an Independent Cost Estimate (ICE) from either the internal independent review board (e.g., the SRB) or from external organizations outside of NASA (e.g., Aerospace Corp.). These reviews typically include schedule assessments as well.

#### **3.12.3.2 Process for Developing Independent Cost and Schedule Assessments**

- a. Projects that require an independent cost and/or schedule estimate or assessment should contact the GRC PPCO, Code BC. For most Projects at GRC, the PPCO will conduct the analysis. Should Projects desire to get an estimate from an outside source, the Project can contact the PPCO for guidance on the SOW development, a list of potential contractors, and other details related to the procurement.
- b. The typical process used by the PPCO follows:
  - (1) Establish customer needs (i.e., type of analysis, Project customer, due dates, etc.).
  - (2) Establish the technical and programmatic baselines:
    - (a) Define the technical characteristics (e.g., master equipment list, layout diagrams, dimensions, software needs and lines of code, PBS, Government-furnished equipment, and test requirements and locations).
    - (b) Define the programmatic information (e.g., Project WBS, schedule, partner roles, contributions, and estimated life cycle).
  - (3) Conduct the cost analysis following these typical steps:
    - (a) Collect and analyze the technical and programmatic data.
    - (b) Determine the estimating level based on the WBS and available information.
    - (c) Identify alternative estimating approaches and evaluate them based on the appropriateness and availability of data.

- (d) Identify the primary estimating approach and possibly a secondary approach to use as a cross-check.
- (e) Develop, refine, and run the Cost Model(s)
- (4) Conduct the schedule analysis using one or more of the following methods:
  - (a) If available, summarize the schedule output of the cost-estimating tool.
  - (b) Collect and analyze analogous mission schedule data.
  - (c) Collect the data necessary to exercise available schedule-estimating relationships.
- (5) Document and present and/or defend the analysis.

### **3.13 Perform Annual Planning, Programming, Budgeting, and Execution Process**

#### **3.13.1 Purpose**

The purpose of this section is to provide background information and a process for complying with the Agency and GRC annual budget planning and execution process. NPR 9420.1 provides requirements and a general overview on how to develop, refine, justify, and submit NASA's annual request for direct budget authority to be appropriated by Congress. It includes information on establishing NASA budget estimates in the Government-wide President's Budget Request, and an overview of how the Agency monitors the Congressional appropriations process. NPR 9420.1 focuses on budget formulation, which comprises the first three phases of the Agency's four-phase PPBE process.

#### **3.13.2 Rationale**

- a. Through the NASA PPBE process, GRC Projects and Tasks negotiate and establish CS labor, travel, and procurement resources required to meet the baseline budget performance plan.
- b. This section defines a GRC standing operating practice and does not satisfy any requirements in the Compliance Matrix (Appendix C).

#### **3.13.3 Planning, Programming, Budgeting, and Execution Process**

- a. This section focuses on budget formulation, which begins at the end of the Planning Phase with the Strategic Planning Guidance (SPG) and ends with the development of the project phasing plans for execution. The guiding NPR for this activity is NPR 9420.1. For SFS Projects and Tasks, the PPBE process requires inputs to the Program Office, lead center, or customer, which in turn are used to provide inputs into the various steps of the Agency PPBE process. The Center CFO coordinates and interfaces with the HQ CFO for the PPBE milestones shown in the following section.
- b. During the PPBE cycle, the CFO Office at GRC requests that the SFS Directorate review the PPBE information to identify any disconnects or issues relative to funding or FTE support. The verifications could potentially occur at the release of the SPG, Program and Resource Guidance (PRG), Program Analysis and Alignment (PAA), and Programmatic and Institution Guidance (PaIG) milestones.
- c. Concurrently, each Project/Task works with the Program Office, lead center, or customer in the PPBE process defined by the Program Office to develop and submit their PPBE input.

During this process, each Office in the Space Flight Systems Directorate will provide an informational summary of the Projects/Tasks in their portfolio to the PRB.

- d. The Portfolio Integration Lead, RA, or PP&C lead utilizes the agreed-to data to provide workforce demand input for Center workforce planning activities and/or into the Center PRD system <https://workforce.grc.nasa.gov/prd.asp>

### 3.14 Estimate Center Program Direct Assessments (PDAs)

#### 3.14.1 Purpose

The purpose of this section is to establish the process by which the SFS Directorate estimates and collects PDAs from SFS Projects and Tasks at GRC.

#### 3.14.2 Rationale

- a. PDAs apply to all new and ongoing NASA-funded programmatic business involving the SFS Directorate at GRC, regardless of which organization sponsors the pursuit and regardless of opportunity size. The assessments apply to all organizational elements at GRC's Lewis Field campus and Armstrong Test Facility.
- b. The assessments have a limited applicability to SFS Directorate work funded via Space Act Agreements (SAAs), as follows:
  - (1) ODCs are not applied to any SAAs because those costs are collected under Center Engineering and Safety Operations.
  - (2) Test and Fabrication services assessments may be applied as appropriate to the specific technical work scope required by each SAA.
- c. Administration of this process is delegated by the SFS Directorate to the Program/Project Integration Office (Code MB), which is responsible for planning, allocating and collecting PDAs and ensuring compliance across the SFS programmatic portfolio.

#### 3.14.3 Space Flight Systems Assessment Process Definitions

- a. PDAs are a cost of doing business with GRC, distributable to GRC's NASA-funded programs, Projects, subprojects, Tasks, and research activities. PDAs are divided into two categories: GRC Center Direct Assessments (CDAs) and Test and Fabrication Services.
- b. CDAs are functional costs distributable to the programmatic portfolio by the institutional, performing, and Project management organizations. These costs are for products and services utilized by Projects. Current CDA categories follow:
  - (1) **Infrastructure Services**—Provides IT end user services. This cost includes items such as computer hardware, software support, and phones.
  - (2) **Cybersecurity Assessment & Authorization** —Provides continuous monitoring and independent reviews for IT security plans.
  - (3) **Cloud & Computer Services**—Provides Data Center, High Performance Computing and Dell Unity Storage
  - (4) **Software Licenses IT Direct (Engineering Software Licenses and Associated Hardware)**—Provides engineering software licenses, and hardware that are broadly used by multiple programmatic customers.

- (5) **Metrology**—Metrology includes Inspection, acceptance testing, calibration, repairs, and maintenance of instrumentation, measurement and test equipment, management of the Center recall system.
  - (6) **Inventory**—Provides for various purchases (non-bankcard) made through the Glenn Supply Management System (e.g., tote boxes, engineering notebooks, envelopes, gas cylinders, batteries, paper, and cans of compressed air).
  - (7) **Logistics**—Logistics Includes, Freight, Gasoline, Laundry, Motor Pool, embedded GSA leased vehicles, Move Ops, Specialty Gas Management System, Space Management, Vehicle maintenance/parts, Temporary Inactive Equipment Storage, Furniture Purchases, Airport Courier.
  - (8) **Project Management Core Capabilities**—Provides funding for cross-cutting capability development and maintenance in Project management processes, tools, training, process improvement, IT integration, and new business support.
- c. Test and Fabrication services are a method of collecting funds from the Projects/Tasks to pay for technicians/engineers and associated overhead and maintenance for testing and manufacturing activities required by the Projects/Tasks. Current services are defined as:
- (1) **Test Services**—Provides funding to pay for test facility maintenance, data systems support, and operations expenses (e.g., stock, cryogenic support, CM, and administration support). It also provides funding to pay labor costs for GRC facility test technicians and facility test engineers.
  - (2) **Fabrication Services** —Provides funding to pay for the services, support, and maintenance associated with manufacturing support and facilities.

#### 3.14.4 Direct Assessments Procedure

- a. Responsibilities for the various organizations and governance boards follows:
  - (1) The GRC Special Mission Support Council (Special MSC) is responsible for reviewing, approving, establishing, and delegating assessments for CDAs and Test and Fabrication Services to GRC programs and Projects.
  - (2) The Director of SFS is responsible for establishing policy, providing guidance, and serving as the SFS representative on the Special MSC.
  - (3) The Program/Project Integration Office is responsible for implementing the requirements and guidance in this GLPR to SFS programs and Projects. Code MB is also responsible for providing annual recommendations of assessment methods and allocations. Specific questions regarding the implementation of this policy should be addressed to the attention of the Program/Project Integration Office.
  - (4) SFS offices overseeing Projects/Tasks are responsible for paying their allocated assessments to meet funding requirements.
- b. The SFS PDA procedure follows the processes described in the following list:
  - (1) CDAs should be allocated to all NASA-funded SFS Projects based on a method of allocation approved by the Director of SFS with concurrence from SFS management prior to the start of the fiscal year.

- (2) Planning guidance will be provided at the beginning of the PPBE planning phase for each fiscal year, the allocation will be finalized at the start of each fiscal year and reviewed quarterly during the fiscal year. The allocation could be adjusted if there is a significant change to assessments or Program/Project/Task assignments.
- (3) Nonlabor revenue should be based on the most current information available as reflected in SFS's portfolio map. Allocations should be given to each office in the SFS Directorate.
- (4) Each office needs to determine the lower-level allocation down to the specific financial six-digit WBSs, or lower as applicable.
- (5) Allocations should be applied to all new NASA-funded business opportunities involving the SFS Directorate at GRC, regardless of which GRC organization sponsors the pursuit and regardless of opportunity size.
- (6) CDAs should not be applied to any non-NASA work funded via an SAA.
- (7) Test and Fabrication Services should be allocated to SFS's Projects/Tasks based on their planned utilization of the performing organizations that provide the support.
  - (a) Current planning rates can be determined using GRC's proposal Cost Model, which is maintained by the OCFO (attention Code BC, PPCO).
  - (b) Additional planning guidance to ensure that all costs are covered is provided through the PPBE.
- (8) All pass-through funds will be reviewed annually. The following pass-through funds are subject to a 2-percent assessment:
  - (a) International Space Station Research Program funds that are awarded as university grants or cooperative agreements to awardees selected by HQ.
  - (b) Any additional funds approved by the Chief of the Program/Project Integration Office (Code MB).
- (9) All SFS Assessments will be managed, maintained, distributed the Program/Project Integration Office (Code MB).

### **3.15 Develop Resource Phasing Plans**

#### **3.15.1 Purpose**

The purpose of this section is to describe the process by which Project and Tasks are expected to develop annual resource phasing plans to define the overall budget and FTE utilization plan for the upcoming/current year of execution.

#### **3.15.2 Rationale**

- a. Resource phasing plans are necessary to document the Project/Task plan for utilizing resources by month for the planned year of execution. GRC's OCFO requires these plans prior to the start of the new fiscal year to serve as the plan for budget obligations, costs, and FTE against which actual performance is then measured and reported by the PM during periodic reporting.
- b. The phasing plan should be consistent with the RLS to ensure that the Project/Task has planned, and is executing to, an integrated cost-schedule performance baseline.

- c. This section defines a GRC standard operating practice and does not satisfy any requirements in the Compliance Matrix (Appendix C).

### **3.15.3 Phasing Plan Development Process**

- a. The RA works with the PM (or IM if assigned for Gold Class Projects) and with the CAMs to develop annual phasing plans for each WBS element or the Project/Task as a whole for Silver/Bronze Classes. The RA (or IM if assigned) will utilize the Phasing Plan template. Procurements, service pools, FTE and labor dollars, and travel funds are entered into the template. The phasing plan should show obligations and costs by month and should also account for uncosted or unobligated carry-in as well as uncosted carry-out.
- b. Once the template is complete, the RA coordinates with the OCFO budget analyst to prepare the data. Typically, the phasing plan is developed for a Project in the first quarter of the fiscal year, with updates being done to reflect Project changes in the third quarter. Phasing Plan Template Location on OCFO Portal [Phasing Plan Template Location on OCFO Portal: https://nasa.sharepoint.com/sites/grc-ocfo/SitePages/Useful-Links-%E2%80%93-Cost-Estimating.aspx](https://nasa.sharepoint.com/sites/grc-ocfo/SitePages/Useful-Links-%E2%80%93-Cost-Estimating.aspx)  Cost\_Phasing.docx

## **3.16 Acquire Performance-Based Contractor Support**

### **3.16.1 Purpose**

The purpose of this section is to provide guidance for Projects/Tasks to use in acquiring staff from any one of several specialized Performance Based Contracts that the GRC Procurement Office has awarded to help performing organizations acquire additional workforce support that cannot be provided by the CS workforce, or a specialized skill that the current GRC CS workforce does not possess.

### **3.16.2 Rationale**

- a. GRC work needs to maintain its workforce flexibility, and sustain its core competencies, to respond to changing budgets without adversely affecting the CS workforce.
- b. This section defines a GRC standard operating procedure and does not satisfy any requirements in the Compliance Matrix (Appendix C).

### **3.16.3 Performance-Based Contractor Support Information**

- a. Each support service contract contains specific provisions for acquiring contract support. Consult with the Contracting Officer (CO) specifically assigned to the contract to obtain the required services based on the requirements of the contract.
- b. For a list of all On-Site contracts and their respective information, please see the “Glenn Research Center On-Site Prime Contractors” section at <https://www.nasa.gov/glenn-business-and-partnerships/>. For any further details on contractual matters, please contact the NASA GRC Office of Procurement, found at <https://nasa.sharepoint.com/sites/grc-procurement>.
- c. The PM, CAM, or other prospective user of a contract should contact either the CO or the assigned COR for more details on the specific procedures and forms to use to initiate a task or work order on the contract because these procedures will vary for different contracts.

## **3.17 Acquire External Contractor Products and Services**

### **3.17.1 Purpose**

The purpose of this section is to provide basic information about the process for procuring external contractor support for products and services which Projects/Tasks may require outside of what GRC can provide internally. This section provides the basic information for acquiring external products and services identified in the Project planning process.

### **3.17.2 Rationale**

This section relates to Number 54 (NPR 7120.5 requirement Table 1-4, “Project Plan Control Plans Maturity Matrix, Item 4) in the Compliance Matrix for the Project (Appendix C).

### **3.17.3 Procurement Process Information**

- a. Depending on the requirements of the Task or Project, acquisition of outside products and services needs to follow a strict procurement process. In accordance with Federal Acquisition Regulation (FAR) requirements, the procurement process rules and requirements become more vigorous as the costs to purchase products and services increase. Projects with higher acquisition costs and visibility document their procurement strategy in a separate Acquisition Plan, an acquisition strategy in an FA, or the acquisition section of the PP.
- b. It is important to start this process early because procurements can take from months to years, depending on the dollar value. For specific procurement instructions see GLPR 5100.1, which explains the overall process and specific information about the GRC purchasing process.

## **3.18 Perform Continuous Risk Management and RIDM**

### **3.18.1 Purpose**

The purpose of this section is to provide guidance for the Project/Task to adopt CRM and RIDM.

### **3.18.2 Rationale**

- a. Since their introduction and until recently, NASA risk management processes have been based on CRM, which stresses the management of risk during the Implementation phase of the NASA Program/Project life cycle. In December 2008, NASA issued NPR 8000.4, which introduced RIDM as a complementary process to CRM. RIDM is concerned with the analysis of important and/or direction-setting decisions. In the past, risk management was considered equivalent to CRM; now, risk management is defined as comprising both CRM and RIDM.
- b. This section relates to Number 53 (NPR 7120.5 requirement Table 1-5, “Project Plan Control Plans Maturity Matrix,” Item 3) in the Compliance Matrix for the Project (Appendix C).

### **3.18.3 Continuous Risk Management and RIDM Process**

Risk management methodology emphasizes the proper use of risk analysis in its broadest sense to make risk-informed decisions that impact the mission execution domains of safety, technical, cost, and schedule. The three main components of risk management are:

- a. Risk identification and record.
- b. Risk factor plotting onto 5-by-5 risk matrix charts for reporting purposes.
- c. Active mitigation and management of risks using CRM processes.

### 3.18.4 Continuous Risk Management and Risk-Informed Decision-Making Procedures

- a. Projects/Tasks should apply the CRM requirements from the next higher tier's Risk Management Plan, if one exists, as a priority. A Project should only create a Risk Management Plan if no higher tier plan exists.
- b. Refer to GLPR 8000.4 for general direction specific to GRC. This document follows the Risk Management Procedural Requirements described in NPR 8000.4.

### 3.18.5 Additional Resources

- a. For more in depth information concerning CRM and RIDM, consult NASA/SP—2011-3422, "NASA Risk Management Handbook" (available at <http://ntrs.nasa.gov>). This document addresses numerous specific aspects that relate to CRM and RIDM processes.
- b. NASA/SP—2010-576 (available at <http://ntrs.nasa.gov>) provides guidance for analyzing decision alternatives in a risk-informed fashion.
- c. The Risk Management Implementation Tool (RMIT) is a Web-based application developed to aid NASA PMs and Project members in performing CRM. Registration is required through NAMS/IdMax to use this application. The application follows the terminology and principles defined in the Software Engineering Institute's (SEI's) "Continuous Risk Management Guidebook." This manual is divided into two parts:
  - (1) Continuous Risk Management
    - (a) This section provides an overview of the CRM process.
    - (b) The material from this section is taken from SEI's "Continuous Risk Management Guidebook" and is just a brief overview.
  - (2) The RMIT Application

This section provides a user guide for using the RMIT Application. It describes the main pages of the application and provides a "how to" tutorial for performing the various tasks.

## 3.19 Perform EVM

### 3.19.1 Purpose

The purpose of this section is to provide guidance applicable to Projects to establish the EVM process.

### 3.19.2 Rationale

EVM is a project management process that seeks to integrate the Project technical scope with cost, schedule, and performance elements to realize optimum PP&C. The two major objectives of an EVM System (EVMS) are to: (1) to encourage PMs to use effective internal cost and schedule management control systems and (2) to produce timely data for customers to use in determining product-oriented contract status. EVM requires that all work is planned, budgeted, and scheduled in time-phased "planned value" increments constituting an integrated cost and schedule performance measurement baseline. This section relates to Numbers 78 through 80 (NPR 7120.5 requirements 2.2.8, 2.2.8.1, and 2.2.8.2) in the Compliance Matrix for the Project (Appendix C).

### 3.19.3 EVM Process

- a. EVM is performed, at the discretion of the Mission Directorate Associate Administrator (MDAA), for Projects in Phases B, C, and D that have a life-cycle cost (LCC) estimated to be greater than \$250 million. EVM also is performed when modifications, enhancements, or upgrades are made during Phase E of a Project when the estimated development costs are greater than \$250 million. LCC includes pass-through funding.
- b. EVM planning begins during Formulation. Projects should use an EVMS that complies with the guidelines in ANSI/EIA-748, and the system should be described in the PP.
- c. When appropriate, a Project flows down EVM system requirements to applicable suppliers in accordance with the NFS. This includes in-house work elements. (See Appendix A for a definition of “suppliers.”) For contracts that require EVM, a Contract Performance Report, an IMS, and a WBS with the appropriate data requirements are expected deliverables.
- d. The MDs conduct a preapproval Integrated Baseline Review (IBR) as part of the preparation for KDP C to ensure that the Project’s work is properly linked with its cost, schedule, and risk, and to ensure that the management processes are in place to conduct project-level EVM.

### 3.19.4 Additional Resources

- a. See GRC’s EVM Web site for more procurement guidance and sample data requirement document information. This website provides guidance and reference information for in-house and contract application of EVM using the Agency EVM capability.  
<https://nasa.sharepoint.com/sites/grc-ocfo/SitePages/Earned-Value-Management.aspx>
- b. Projects requiring EVM should contact the EVM focal point in PPCO for assistance in project and contract Request for Proposal (RFP) preparation.
- c. NFS 1834 is applied to contractors and subcontractors.

## 3.20 Perform Budget and Schedule Variance Analysis

### 3.20.1 Purpose

The purpose of this section is to describe the process by which Projects and Tasks should perform budget and schedule variance analysis in support of the periodic reporting process in Section 3.23.

### 3.20.2 Rationale

Although always the goal, Projects and Tasks rarely stay directly on their baselined budget and schedule performance plans. Once performance begins to vary from plan, it is critically important to analyze why this is occurring so that the PM can inform GRC and customer management authorities as soon as the variance is identified, and that early development of corrective actions can be initiated to bring performance back on plan.







### 3.20.3 Budget Variance Reporting Procedure

- a. The RA:

- (1) Is responsible for pulling resource (funding, commitments, obligations, costing, and FTE utilization) information from NASA financial systems (SAP Core Financial, Business Objects (BOBJ), and GRC OCFO Standard Reports) and analyzing them for variance against the fiscal year phasing plan.
- (2) Should perform a monthly variance analysis, at a minimum. A variance analysis should be generated whenever the thresholds shown in Figure 3-8 are exceeded. The variance analysis should address cause, impact, corrective action, and/or when the project will be back on plan.
- (3) Should contact the CAMs or other Project team personnel as required to obtain a variance explanation before providing the reports to the PM for period reporting to the GRC management authority per Section 2.2.

b. The PM is responsible for:

- (1) Reviewing the SAP Core Financial, BOBJ, and GRC OCFO Standard Reports provided by the RA and for reporting them to the responsible GRC management authority, at a minimum, using the procedures and formats described in Section 3.23.
- (2) Developing contingency budget execution tactics, as well as recovery plans to get back on the phasing plan, building on the reports and analysis provided by the RA.

<b>Obligations:</b>	
	<b>Red</b> = Negative Variance Exceeding 5% and over \$1 million
	<b>Yellow</b> = Negative Variance Less Than 5% or under \$1 million
	<b>Green</b> = No Negative Variance
<b>Costs:</b>	
	<b>Red</b> = Variance (+ or -) Exceeding 10% and over \$1 million
	<b>Yellow</b> = Variance (+ or -) Exceeding 5% and over \$500K
	<b>Green</b> = Variance (+ or -) Less Than 5% or Under \$500K

**Figure 3-8. Thresholds for Reportable Budget Variance, and Example as Reported**

### 3.20.4 Schedule Variance Reporting Procedure

3.20.4.1 The Scheduler (or PM if no Scheduler assigned):

- a. Is responsible for obtaining the status of schedule activities on a periodic basis (monthly for most Projects/Tasks) from the CAMs, then entering the updated percent complete, actual start and/or finish dates, remaining duration, and remaining work into the scheduling software tool (e.g., MS Project) monthly, at a minimum.
- b. Should:
  - (1) Perform a monthly variance analysis by comparing the updated schedule plan against the baseline schedule developed per Section 3.8. The schedule variance can be evaluated directly in the scheduling software tool by viewing baseline schedule activities in comparison to current forecasted activity dates, as shown in Figure 3-9. The schedule variance analysis should include an evaluation of the root cause of schedule deviation, such as changes in resource availability, late or early key deliveries, unexpected additional work activities, and risks. Note that thresholds for reporting schedule variances will typically vary by project size, complexity, and risk. The thresholds should be

formally defined in the PP for most projects, or in the Cost and Schedule Control Plan for Gold Class Projects and should account for the number of days activity is delayed, as well as available float.

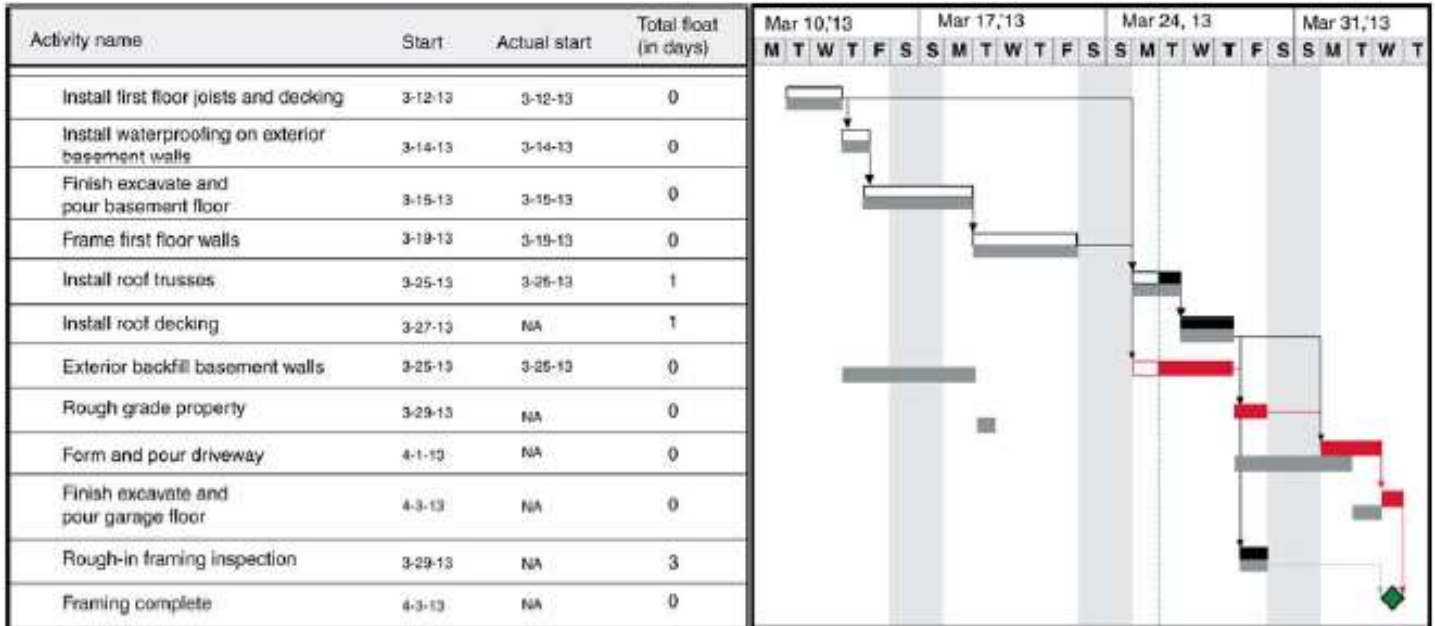
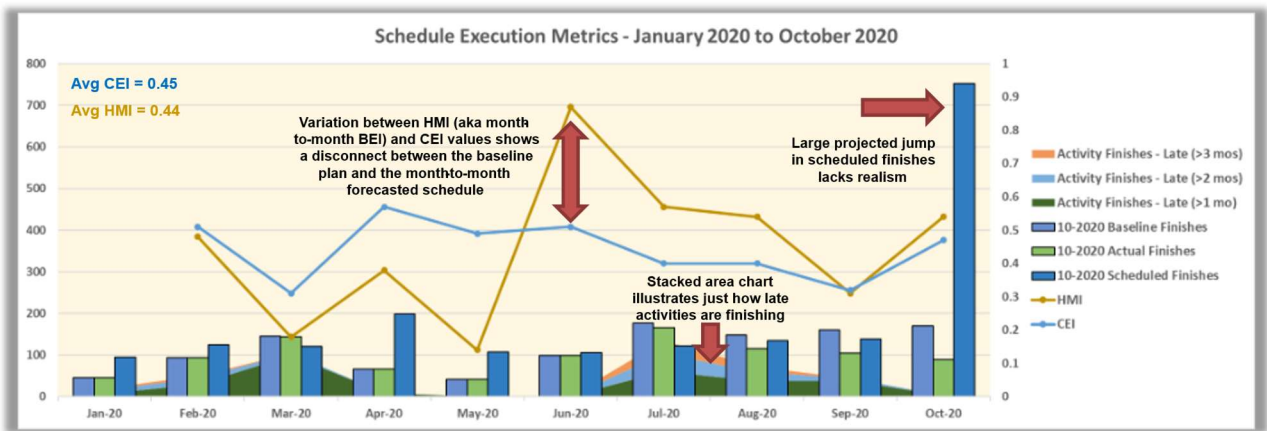

**Figure 3-9. Example of Updated Schedule Status Compared with Baseline**

- (2) Coordinate with the CAMs or other team personnel as required to obtain an explanation of the variance and should develop “what-if” options and recommended corrective actions.
- (3) Run the Agency-provided tool, Acumen Fuse, to extricate variance metrics; document the analysis results and variance explanations; and make corrective action recommendations. Examples of Acumen Fuse variance output are depicted in Figure 3-10 and Figure 3-11. The reports should be provided to the PM for period reporting to the GRC management authority per Section 2.2.

3.20.4.2 The PM is responsible for:

- a. Reviewing the reports provided by the Scheduler and for reporting them to the responsible GRC management authority, at a minimum, using the procedures and formats described in Section 3.23.
- b. Developing contingency schedule execution tactics, as well as recovery plans to get back on the schedule plan, building on the reports and analysis provided by the Scheduler.



**Figure 3-10. Example of Acumen Fuse Schedule Variance Report**

*Note: This space left intentionally blank. Figure 3-11 starts on next page.*

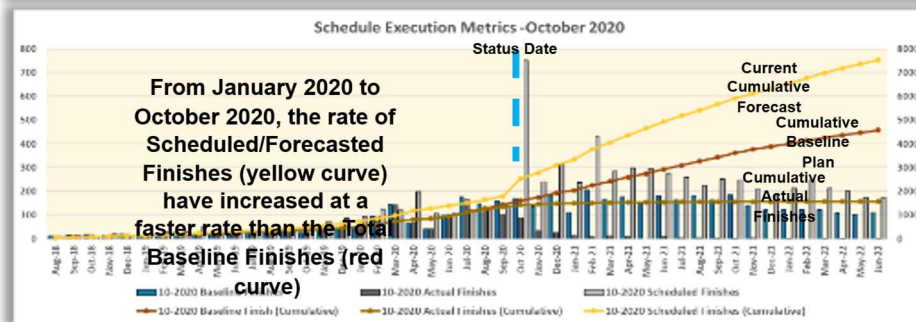
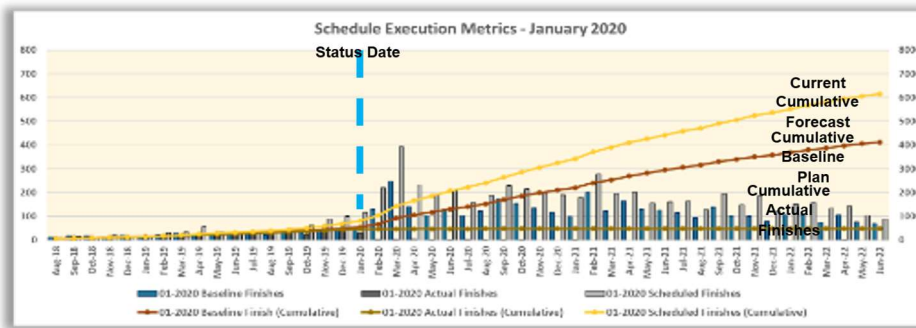
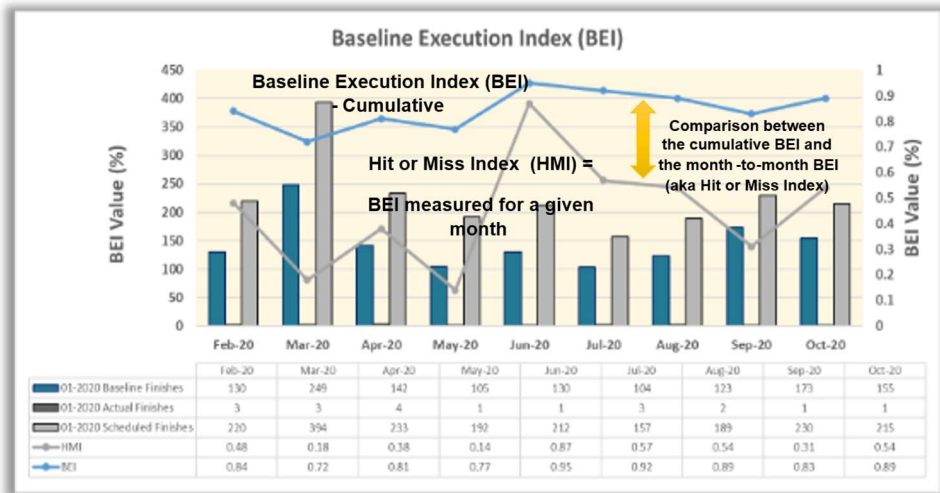
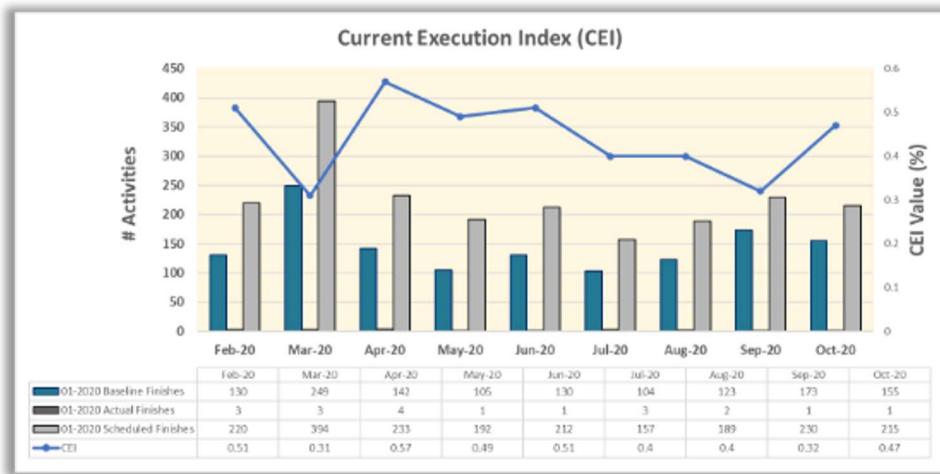

**Figure 3-11. Example of Acumen Fuse Schedule Variance Management Report**

### 3.21 Operate Project Control Board (PCB)

#### 3.21.1 Purpose

The purpose of this section is to describe the process for establishing a PCB and to outline responsibilities for the entire PCB cycle, from the original initiation of a Project/Task PCB through final recording and archiving of the PCB's results.

#### 3.21.2 Rationale

The benefit of this procedure is that it establishes a standard method for forming and convening PCBs for all GRC Project/Task activities managed by the SFS Directorate. The PCBs are typically used for the following:

- a. Approve and control the technical, budget, and schedule performance baseline of the Project/Task.
- b. Provide a leadership advisory board for the PM to obtain technical advice and expert recommendations in making decisions as the ultimate programmatic and technical authority for the Project/Task.
- c. Serve as a preboard for products, reports, and decision recommendations that are delivered to GRC management authorities and external customers and/or stakeholders, when required.

*Note: The PCB is not intended to replace or be a substitute for Project/Task technical reviews or other reviews defined by NPR 7120.5.*

#### 3.21.3 Project Control Board Procedure

##### 3.21.3.1 Project Control Board Charter

The PM, in partnership with the CE, CSO, and C/DM, should develop a written charter for the Project/Task PCB, using the template in Appendix I as a starting point. The workflow shown in Figure 3-12 should be used to develop and obtain approval for the PCB charter.

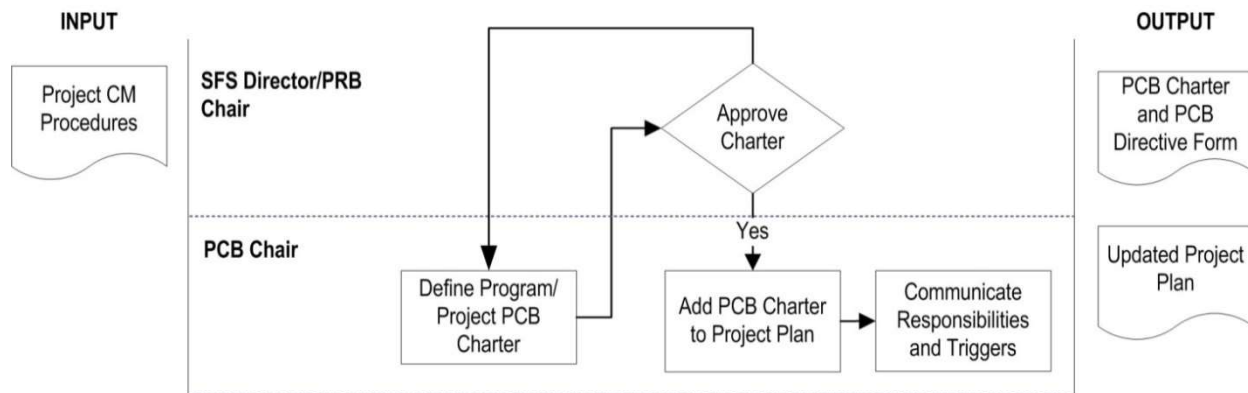

Figure 3-12. PCB Formulation Flow

##### 3.21.3.2 Roles and Responsibilities

- a. PCB Chair: The PM will serve as the chair for all PCB activities within a Project. Responsibilities of the PCB Chair are:

- (1) Define requirements for the PCB review and establish the PCB charter.
- (2) Review and approve Project PCB requests.
- (3) Convene and preside over the PCB.
- (4) Preside over PCB presentations and approve or reject recommendations, document disposition, and sign the PCB directive form. The PCB Chair will consider all input from the membership by polling the participants prior to finalizing the disposition and closing the PCB.
- (5) Identify issues and assign actions required to close the PCB, and review actions taken by assigned individuals to close identified issues.
- (6) Record liens against cost or schedule as a result of an approved change.
- (7) As required, ensure that the PCB recommendation is presented to the customer and the PRB and/or Project/Task stakeholders for final approval. Presenter is determined at the discretion of the PM.

b. PCB Executive Officer

- (1) The C/DM officer assigned to the Project/Task should serve as the PCB Executive Officer.
- (2) Is responsible for reviewing the PCB materials for completeness prior to submitting to the PCB Chair and is responsible for ensuring quality discipline products by providing opinions based on expertise and experience to help formulate the PCB recommendation.
- (3) Will administer all PCB procedures and actions and will serve as recorder at all PCB meetings.
- (4) Develops, publishes, and distributes the agendas and meeting schedules to designated members, and distributes the presentation material to board members for their review prior to meetings.
- (5) Schedules PCB meetings, documents attendance, records the minutes of each meeting, and distributes final minutes to each member within five business days of approval.
- (6) Additional Responsibilities of the PCB Executive Officer are:
  - (a) Archive all PCB inputs and outputs.
  - (b) Ensure that required coordination of changes is completed prior to implementation.
  - (c) Ensure that the PCB action is documented.
  - (d) Maintain a file of applicable regulations, policies, and correspondence.
  - (e) Take meeting notes and capture comments.
  - (f) Document all Action Items including owners and due dates.
  - (g) Keep track of unanswered questions and review them at the end of the session.
  - (h) Track completed configuration change requirements per the PCB decisions and archive the updated configuration items.

c. Permanent PCB Members: The following roles should be named permanent PCB members:

- (1) PM and DPM
  - (2) CE or PLE
  - (3) CSO or SMA Lead
  - (4) PI (for science-related projects)
  - (5) LSE
  - (6) CAMs
  - (7) C/DM
- d. Other PCB Members: Nonpermanent members participating in the PCB will depend on the subject matter and expertise required to effect sound engineering decisions and to ensure that all aspects of the design have been considered and integrated.

#### **3.21.4 Project Control Board Purpose**

- a. The following triggers for a typical PCB should be tailored as appropriate and documented in the PCB Charter:
- (1) Any change or decision that exceeds the delegated authority of lower-level boards or that cannot be adequately resolved at a lower level in the Project/Task organization.
  - (2) The discretion of the PM.
  - (3) Changes to the Project/Task budget, schedule, and technical baseline.
  - (4) Changes that impact schedule milestones.
  - (5) Changes to configuration-controlled documents.
  - (6) Requests for DWs.
  - (7) Changes that add risk to the Project/Task as determined by the Project/Task CRM/RIDM process, and/or its RMB.
  - (8) Approval of risk mitigation plans when the PCB functions as an RMB.
  - (9) Changes that impact multiple WBS elements.
  - (10) Review of major milestone deliverables.
  - (11) Liens and threats to the Project/Task budget.
  - (12) Proposals for new Project scope.
- b. The PCB Directive template (GRC form 2066; see Appendix I) should be used to document every decision made by the PCB. It will serve as an official record of PCB purpose, member votes, Formal Dissents, actions, and decisions/recommendations.

#### **3.21.5 Request and Perform PCB**

- a. The PM and Project/Task team should operate the PCB using the routine procedure shown in Figure 3-13.
- b. If a particular topic cannot be considered as part of routine PCB scheduling, the requestor will request a PCB review topic from the PCB Chair.

- c. The PCB Chair will poll the members at the end of the discussion on their positions relative to the recommendation(s) being asked of the PCB.
- d. Final decision on PCB recommendations and/or decisions will be made by the PCB Chair.
- e. Resulting additional candidate risks will be specifically asked for by the PCB Chair after the PCB recommendation is made. The PCB Secretary will capture action/assignment to document any new risks.
- f. Formal Dissents will be acknowledged as part of the PCB results. They will be reported to the customer and the PRB and documented in the PCB Directive Form.
- g. PCB Chair will issue actions with due dates required to close the PCB topic. This can include scheduling a higher-level review of the PCB recommendation.
- h. The PCB Secretary records all actions, assigned owners, and due dates for each action on the PCB Directive Form and Action Item log, as applicable.
- i. The C/DM updates Project records and verifies that change records in configured items are properly documented.
- j. The C/DM signs off on the PCB Directive to formally close the PCB topic.

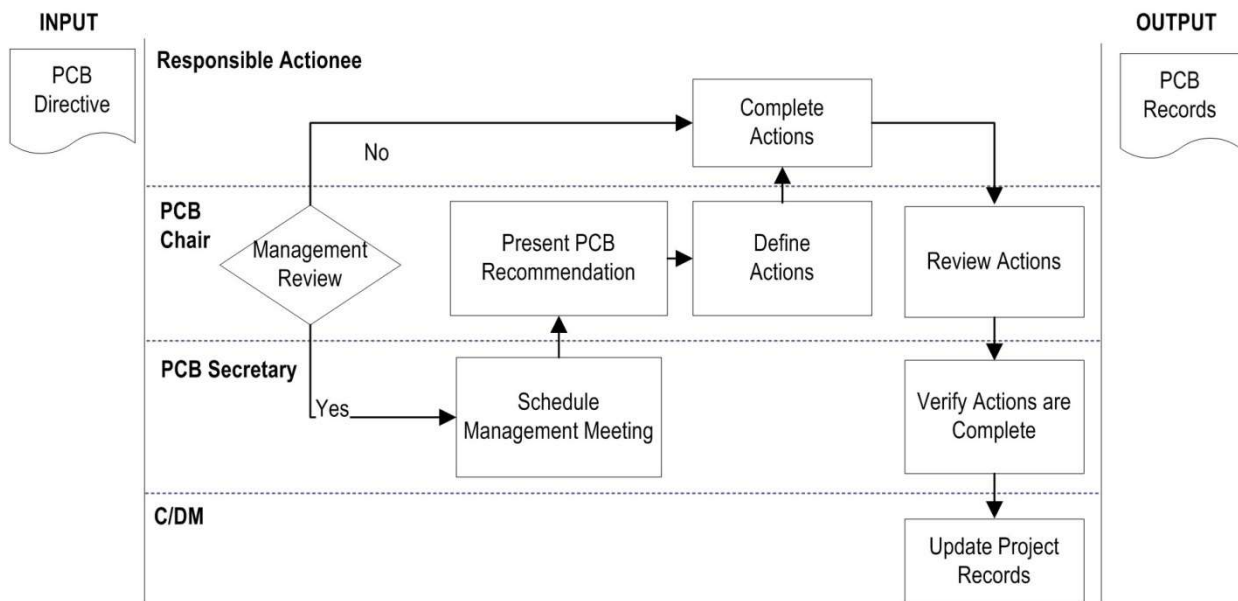

**Figure 3-13. PCB Operating Flow**

### 3.22 Perform Technical Management

#### 3.22.1 Purpose

The purpose of this section is to describe how the PM works in partnership with the CE, CSO, LSE, and the CAMs to provide day-to-day technical management of the Project/Task. It summarizes a set of key technical management functions that will be performed at various times during the Project/Task life cycle.

### 3.22.2 Rationale

- a. Every Project/Task involves a set of day-to-day activities that fall into two areas: programmatic and technical. The PM is ultimately responsible for everything that occurs in both these areas. Therefore, the PM must establish efficient management processes and close working relationships with the CE to enable effective leadership of the engineering technical aspects, and with the CSO to enable the same for the SMA technical aspects.
- b. This section provides procedures that relate to compliance with requirement 2.7a of GLPR 7120.5.10. Technical management processes are intended to supplement the management requirements defined in NPR 7120.5.

### 3.22.3 Technical Management Processes

- a. Refer to Section 3.3.3 for the standard team organization chart template (Figure 3-1). This template illustrates the relationship that exists between the PM, CE/PLE, LSE, and the CAMs. The PM is responsible for building a highly effective working relationship with every team member fulfilling a leadership role on the team. Moreover, the PM should exert management control and leadership over both the programmatic aspects (i.e., budget and schedule) and the technical aspects (i.e., requirements, designs, assembly/integration/test, verification/validation, system acceptance, and delivery of the system/product to the customer) of the Project/Task.

*Note: The PM should exert both programmatic and technical leadership and management by establishing and operating a PCB per Section 2.2, or equivalent.*

- b. There are eight technical management processes: Planning, Requirements Management, Interface Management, Technical Risk Management, Configuration Management, Data Management, Assessment, and Decision Analysis. These are summarized in more detail in the following subsections.
- c. The technical management processes work in conjunction with the system design and product realization processes to produce engineering products throughout the project lifecycle. These processes are fully described in NPR 7123.1 and in the NASA Systems Engineering Handbook (NASA/SP-2016-6105) (<http://ntrs.nasa.gov>).

### 3.22.4 Technical Planning

The technical planning process is used to plan for the application and management of each common technical process. It is also used to identify, define, and plan the technical effort applicable to the product life-cycle phase for the product layer location within the system structure and to meet project objectives and product life-cycle phase exit criteria. Detailed planning is addressed in Section 3.4.

*Note: The results of this technical planning effort should be summarized as input to the technical summary section of the PP required by NPR 7120.5.*

### 3.22.5 Requirements Management

The requirements management process is used to:

- a. Manage the product requirements identified, baselined, and used in the definition of the products of this layer during system design;

- b. Provide bidirectional traceability back to the top-product-layer requirements; and
- c. Manage the changes to established requirement baselines over the life cycle of the system products.

### **3.22.6 Interface Management**

The interface management process is used to:

- a. Establish and use formal interface management to assist in controlling system product development efforts when the efforts are divided between Government programs, contractors, and/or geographically diverse technical teams within the same program or Project.
- b. Maintain interface definition and compliance among the end products and enabling products that compose the system as well as with other systems with which the end products and enabling products should interoperate.

*Note: A less formal interface management approach can be used in conjunction with requirements management and/or CM process activities when the technical effort is collocated in the same Project/Task team.*

### **3.22.7 Technical Risk Management**

The technical risk management process is used to examine on a continuing basis the risks of technical deviations from Project/Task Plans and to identify potential problems before they occur. Technical risk management is performed across the life of the program. See Section 3.18 for recommended processes of CRM.

### **3.22.8 Configuration Management**

The CM process for end products, enabling products, and other work products placed under configuration control is used to:

- a. Identify the configuration of the product or work product at various points in time;
- b. Systematically control changes to the configuration of the product or work product;
- c. Maintain the integrity and traceability of the configuration of the product or work product throughout its life; and
- d. Preserve the records of the product or end product configuration throughout its life cycle, disposing of records in accordance with GLPR 1440.1.

### **3.22.9 Technical Data Management**

The technical data management process is used to:

- a. Provide the basis for identifying and controlling data requirements.
- b. Responsively and economically acquire, access, and distribute data needed to develop, manage, operate, and support system products over their product life.
- c. Manage and dispose of data as records.

- d. Analyze data use.
- e. If any of the technical effort is performed by an external contractor, obtain technical data feedback for managing the contracted technical effort.
- f. Assess the collection of appropriate technical data and information.
- g. Effectively manage authoritative data that defines, describes, analyzes, and characterizes a product life cycle.
- h. Ensure consistent, repeatable use of effective Product Data and Life-Cycle Management processes, best practices, interoperability approaches, methodologies, and traceability.
- i. Ensure product data accessibility and availability, including a method to archive the data.

### 3.22.10 Technical Assessment Process

The technical assessment process is used to help monitor progress of the technical effort and provide status information for support of the system design, product realization, and technical management processes.

- a. **Engineering Review Board (ERB)**— See GLPR 7123.36 for the process and requirements at GRC for conducting ERBs.
- b. **Material Review Board (MRB):** Material review is a defined process to evaluate nonconforming product using technically qualified individuals to determine the appropriate actions to correct the product nonconformance. Material review is the product corrective action activity that, together with anomaly identification and root cause corrective actions to prevent recurrence, comprises the nonconformance system. The MRB is the project board responsible for the disposition of nonconforming product, is chaired by SMA (quality), and will include as a minimum, Project engineering. The MRB may also be given responsibility for determining, or recommending to a Corrective Action Board or PCB, root cause corrective actions to prevent the nonconformance from recurring. To ensure that NASA obtains the highest level of product quality, nonconforming materials need to be adequately and systematically evaluated for their acceptability, or the products need to be made usable through the application of specified corrective actions. The standardization of the MRB process ensures that adequate engineering capabilities and personnel who are knowledgeable of product technological requirements are assembled to recommend and approve the disposition of nonconforming material.
  - (1) Each Project is required to establish and maintain a repository of Project records and products accessible by Project staff and other appropriate Project stakeholders. Each Project should include the following MRB artifacts in this repository:
    - (a) MRB minutes. MRB minutes should record the Non-Conformance Report (NCR), date, personnel present at the MRB, actions assigned, decisions made, and follow-up actions required. When using the GRC Corrective and Preventative Action Reporting (CPAR) system, the NCRs are annotated and updated as necessary to act as the MRB minutes.
    - (b) Standard Repair Procedures.
    - (c) Waivers.

(2) For in-house GRC projects, these NCRs are part of the GRC CPAR system. The following inputs may be needed to assist the MRB and become part of the MRB record. Note that these inputs may also be considered as outputs depending on the circumstance and point in the process when developed:

- (a) Technical analysis
- (b) Manufacturing Instructions
- (c) Testing Instructions

(3) The CE and CSO will jointly evaluate all product nonconformances at the time that they are identified. The nonconformance can be dispositioned as scrap, rework, repair by a standard repair procedure (SRP), repair other than by SRP, return to vendor, regrade, or use-as-is regrade. For all use-as-is and repair dispositions, a waiver should be written and approved by the MRB.

c. **On-Orbit Anomaly Process:** The anomaly process is controlled by the Operations Manual for a given Project/Task that defines the division of authority between GRC and, if used, a Contractor. The process should cover two distinct phases of anomaly resolution: Real-time Operations, and Sustaining Engineering/Post Operations. The Real Time Operations phase consists of the initial response, assessment, and optional resolution of an anomaly. The Sustaining Engineering/Post Operations phase addresses the unresolved operations issues, analyses, and review boards needed to vet and or formalize a resolution.

(1) For the purposes of this On-Orbit Anomaly Process, the following specific roles are defined:

- (a) Project/Task Scientist—Serves as the science liaison between the Project/Task PI or customer and the Project/Task team providing required science-based support in defining science requirements, preparing and maintaining the science requirements documents, and advising the PI on science-related matters throughout the project life cycle.
- (b) Task Lead—A team member who is responsible for supporting execution of on-orbit operations tasks/activities. In this context, the Task Lead should not be confused or equated with the PM of a Level IV Task, per the definitions in Section P.2.
- (c) Test Lead—A team member who is responsible for orchestrating the step-by-step conduct of a specific test which, in this context, is being conducted using on-orbit assets, such as facilities on the International Space Station.
- (d) Engineering Representative (ER)—A branch chief/Discipline Engineer or Chief Engineer from the Research and Engineering Directorate that is a subject matter expert in the anomaly discipline (e.g., power, data/comm) and/or systems engineering.

(2) During the Real Time Operations phase, the team will troubleshoot on-orbit anomalies that could be limited by allocated resources, timelines, and operational constraints. The operations team is responsible for logging all issues and anomalies associated with flight operations and executing applicable alternative or off-nominal procedures as corrective actions. The team should perform an assessment as to whether daily science or Project/Task objectives are impacted and/or on-orbit hardware is threatened. They

will coordinate directly with the GRC Project/Task Scientist, PI, console operations staff, and the Payload Operations Integration Center (POIC) staff when performing the off-nominal operations procedures and obtaining a decision to proceed. Investigation into anomalies that cannot be resolved should be guided by the Test Lead, who is typically either the on-duty Task Lead or the PM performing the Test Lead role. The Test Lead, in coordination with the Project/Task Scientist and the POIC, can authorize continued operations to investigate and resolve the anomaly or can issue an order to shut down operations. Any alternative operations that deviate from the published test procedures should be captured as log notes and/or red lines.

- (3) The sustaining Engineering Process/Post operations phase will allow for detailed engineering analysis to establish the cause of the anomaly and prepare an appropriate troubleshooting and resolution plan. During this phase, all anomalies should be tracked, and a closure plan should be formulated. The anomaly should be categorized as an anomaly or an NCR. The team should perform engineering analysis to identify the root cause and prepare an appropriate resolution plan. An Operations Board Review (OBR) can be established to be a first-level approving authority for the resolution plan. The PM should determine if resolution of the anomaly is successful. If the resolution is successful, then operations can continue, and the resolution should be reported to the OBR. If the resolution is unsuccessful, then the Operations Team should continue with higher fidelity analysis and vetting of resolution plans. If the OBR is deemed inadequate to vet the resolution plan, then an ERB should be held led by the ER. The ERB can then take the required time to develop and recommend an in-depth systems design/engineering approach. The resolution plan may need to be presented to other boards such as the Payload Safety Review Panel, Research Integration Control Board, and Space Station Program Control Board.
- (4) The OBR should review analysis of all operation issues and anomalies. The OBR membership can consist of the PM, project scientist, Task Lead, ER, and CSO/SMA Lead. The review should consist of discussions on each operating day's anomalies and analysis results. For the board discussion, e-mail exchanges can be used for small simple payloads. If a root cause analysis is approved, then the issues should proceed to NCR determination. If no approval or agreement can be reached, then an Operations ERB should be held. The CSO/SMA Lead should determine if an NCR is required for the operational issue. If an NCR is required, then it should be formally reviewed. The NCR process is intended to ensure that all elements directly and indirectly impacted by the root cause issue are sufficiently addressed and that formal documentation of anomalies and issues is produced. After the NCR is approved, the anomaly should be marked as closed in the tracking system.

### **3.22.11 Decision Analysis Process**

The decision analysis process, including processes for identifying decision criteria, identifying alternatives, analyzing alternatives, and selecting an alternative is applied to technical issues to support their resolution. It considers relevant data (e.g., engineering performance, quality, and reliability) and associated uncertainties. This process is used throughout the system life cycle to evaluate the impact of decisions on health and safety, technical, cost, and schedule performance. See GLPR 7123.17 Trade Study Handbook) for more information. Also reference NASA/SP—2010-576 (available at <http://ntrs.nasa.gov>) provides guidance for analyzing decision alternatives in a risk-informed fashion.

### 3.22.12 Additional Resources

For more information about general technical management, see Section C.3 in NPR 7123.1, Appendix C. For more information about data management, see NPD 2200.1, NPR 2200.2, and NPR 1441.1.

## 3.23 Perform Periodic Reporting

### 3.23.1 Purpose

The purpose of this section is to define the typical procedure and format for Project/Task periodic reporting to internal GRC management authorities.

### 3.23.2 Rationale

- a. Providing a period report of the status of the Project/Task progress against technical, budget, and schedule performance baselines, and highlighting current accomplishments, has several benefits, such as keeping all team members and GRC management aware of the Project/Task status and providing a means to highlight valuable contributions from team members to GRC management and to raise issues that management may be able to help resolve.
- b. This section provides procedures that will enable requirement 2.5c of GLPR 7120.5.10 to be complied with. This section relates to Numbers 83 and 84 (NPR 7120.5 requirements 2.3.2 and 2.3.3) in the Compliance Matrix for the Project (Appendix C).

### 3.23.3 Period Reporting Process



- a. Monthly Project Office Reporting. SFS Directorate management requires the chiefs of its customer-facing project offices to report office status monthly, typically at a “stand-up” meeting every Friday morning. The report is presented by the office chiefs based on input from each PM. In addition, highlights are solicited from each PM for rollup into a single submittal from each directorate at GRC that is distributed to senior management.
- b. Monthly-Quarterly Project/Task Reporting. PMs are expected to develop and present a periodic report to GRC management authority in satisfaction of requirement 2.5c of GLPR 7120.5.10. This presentation will typically be given to the responsible project office chief, on a cadence as defined in Table 2-3.

*Note: Reporting progress against the four key criteria of technical, cost, schedule, and management is typically done using a green/yellow/red “stoplight” metric, the criteria for which are shown in Figure 3-14. for SFS internal reporting.*



*Figure 3-14 starts on next page.*

## Stoplight Variance Criteria



### Cost

-  Project variance is less than 5% from current plan (+ or -) or under \$500K; No issues with Project's budget/resources.
-  Project variance is greater than 5%, but less than 10% from current plan (+ or -) and over \$500K; Project's budget/resources for current year are insufficient or reduced, and actions identified to mitigate.
-  Project variance is greater than 10% from current plan (+ or -), and over \$1 Million; Project's budget/resources for current year are significantly insufficient or reduced, and actions not identified to mitigate.



### Schedule

-  Project variance is less than or equal to 1 month from current plan; No issues with Project's schedule margin or resources.
-  Project variance is less than or equal to 3 months from current plan; Project's schedule margin for current year are insufficient or reduced, and actions identified to mitigate.
-  Project variance is greater than 3 months from current plan; Project's schedule margin for current year are significantly insufficient or reduced, and actions not identified to mitigate

### Technical

-  Major requirements are being met by the current design.
-  Major requirements are not being met, but feasible options have been identified and accepted (directed and funded) that will meet all requirements.
-  Major requirements are not being met and options for corrective action are not yet shown to be feasible and/or are not yet directed and funded.

### Management

-  Project implementation is not hampered by lack of resources, including workforce, contracts, project management tools and documentation (requirements, plans, procedures, etc.).
-  Project implementation is limited by the lack of one or more resources, but corrective action has been identified and approved.
-  Project implementation is impacted by the lack of one or more resources, with corrective action not yet identified and/or approved.

**Figure 3-14. Stoplight Variance Criteria for Project/Task Status Reporting**

### 3.24.2 Additional Resources

For Baseline Performance Review reporting for NPR 7120.5 projects in the Formulation, Development or Operations Phases, additional guidance can be found using the Project Reporting Guidance workbook.

## 3.25 Perform Milestone Reviews

### 3.25.1 Purpose

This section provides background information and points to additional resources for the planning and performance of milestone (also called “gate”) reviews and KDP reviews.

### 3.25.2 Rationale

- a. The milestone reviews are required to show that the Project is on track and performing to the technical, budget, and schedule performance baseline plan before the Project proceeds to the next phase of its life cycle.
- b. This section relates to Numbers 15, 16 through 20, 82, and 85 through 90 (NPR 7.120.5 requirements 2.2.4, 2.2.5, 2.2.6, 2.3.1, 2.3.4, and 2.4.1) in the Compliance Matrix for the Project (Appendix C).

### 3.25.3 Milestone Review Information

- a. **See NPR 7120.5 Figure 2-4 NASA Single-Project Program Life Cycle and Figure 2-5 NASA Project Life Cycle.** Each of the standard LCRs is shown in the figure. Each LCR constitutes a gate through which the project must pass an independent technical and management assessment. An independent review board typically performs this assessment. For larger Projects, a formal SRB process is used. For smaller Projects an equivalent independent review board or team is convened in place of an SRB and typically convened by the lead center. These reviews are necessary to make sure that the Project is on track technically, is on schedule, and is on budget, and to have mitigation plans in place if the Project is delinquent in any area. SRB and independent review processes are described in detail in NPR 7123.1. For projects with ‘Silver’ or ‘Bronze’ governance classification and tasks led by GRC, a summary closure report prepared by the LCR chair and submitted to the Convening Authorities (programmatic and technical) without a formal signature is sufficient documentation to allow the project/task to proceed. The Convening Authorities coordinate the subsequent recommendations with the project/task manager.
- b. **See NPR 7120.5 for Pre-Formulation Approval Letter (PAL) requirements** and template. The PAL is issued by the Mission Directorate Associate Administrator (MDAA) and provides the approval authorization to the Program/ Project Manager to initiate pre-formulation, conduct the activities, and develop the products to be completed in Pre-Phase A for a single-Project Program, Category 1 Project, or selected Category II Project.
- c. **See NPR 7120.5. The program and project managers and an independent assessment team shall conduct a Mission Concept Review (MCR).** The review is to be consistent with NPR 7123.1 and the scope contained in the PAL per NPR 7120.5 Appendix J Pre-Formulation Approval Letter Template, and any other parameters specified by the MDAA and noted in the final PAL issued to the program or project.
- d. LCRs are a joint effort between the program or Project and an independent SRB. NASA has issued NASA/SP—2013-02-026-HQ (available at NODIS). The purpose of NASA/SP—2013-02-026-HQ is to provide the philosophy and guidelines for the setup, processes, and products of SRBs in support of the Agency’s implementation of its independent LCR process. NASA/SP—2013-02-026-HQ provides guidance to the NASA program and Project communities and the SRBs regarding the expectations, processes, products, timelines, and

working interfaces with NASA MDs, centers, review organizations, and Management Councils.

### **3.25.4 Additional Resources**

See the “NASA Space Flight Program and Project Management Handbook,” Sections 4 and 5.10, for further information on LCRs.

### **3.26 Process Deviations and Waivers**

- a. GLPR 7120.5.20 explains the requirements at GRC on the implementing organization for performing, supporting, and evaluating deviations or waivers to project requirements in accordance with NPD 7120.4, NASA Engineering and Program/Project Management Policy, NPR 7120.5, NASA Space Flight Program/Project Management Requirements, NPR 7123.1, NASA Systems Engineering Processes and Requirements, NPR 7150.2, and GLPR 7120.5.10.
- b. The DW requirements in GLPR 7120.5.20 apply to projects or tasks led by GRC which have been designated NPR 7120.5 or 7120.8 compliant by an assigning NASA Mission Directorate and/or Program Office, or by GRC Center Management, or by SFS Directorate Management. This includes when the effort is contracted (i.e., “buy” approach), when the effort is a shared responsibility of GRC and a partner, or when the effort is implemented in an “in-house” (i.e., “make” approach) mode.

### **3.27 Project/Task Closeout**

#### **3.27.1 Archive Project Information, Property Excess, and Closeout Initiation**

##### **a. Purpose**

The purpose of this section is to provide the guidance that the Agency expects each Project to follow to archive its information.

##### **b. Rationale**

- (1) Archiving of data and documentation is important to meet the requirements of NPD 1440.1, NASA Records Management for a Government investigation. The documentation can also be used as a starting point for a follow-on effort.
- (2) This section relates to Numbers 34 and 50 (NPR 7120.5 requirement Table 1-4, “Project Management, Planning, and Control Products,” Items 6 and 14) in the Compliance Matrix for the Project (Appendix C).

#### **3.27.2 Project Closeout Procedure**

GRC has established the following procedure for archiving information and closeout activities:

- a. Archive all Project documentation per the CM and Data Management plans.
- b. Provide copies of all data to the program as specified in the Data Management Plan.
- c. Consult with Property and Equipment Management for Project property transfer, storage, and/or excess.
- d. Work with the responsible CO to close out any contracts.

- e. Return all facilities to their original configuration unless otherwise directed.
- f. Provide rewards and recognition to the Project team for their contributions to the Project.

### **3.27.3 Additional Resources**

A general explanation of Project closeout is provided in the “NASA Space Flight Program and Project Management Handbook,” Section 4.4.8 (Phase F).

## **3.28 Develop and Publish Lessons Learned (LL)**

### **3.28.1 Purpose**

The purpose of this section is to describe the LL process, which is a formal methodology to capture knowledge gained from the experience of the work performed over the Project life cycle.

### **3.28.2 Rationale**

- a. Capturing knowledge gained by experience in a database that is accessible to PMs improves project efficiency, performance, and outcomes; promotes validated practices; preserves institutional knowledge; and communicates project experiences in context.
- b. This section relates to Number 70 (NPR 7120.5 requirement Table 1-5, Item 20) in the Compliance Matrix for the Project (Appendix C).

### **3.28.3 LL Process**

- a. A lesson learned is knowledge or understanding gained by experience. The experience may be positive, as in a successful test or mission, or negative, as in a mishap or failure. Successes and failures are both considered sources of LL. A lesson should be significant in that it has a real or assumed impact on activities. LL databases are a rich resource for data mining and development of case studies. The GRC KM website (see Figure 3-3) provides specific instructions on the GRC LL process. The various LL activities will help:
  - (1) Project teams/individuals to reflect on and articulate their experiences, observations, and lessons learned.
  - (2) Project teams/individuals to utilize their expertise and experience to record recommendations or solutions.
  - (3) Project teams to record Project lessons for the benefit of their team, future project phases, and/or other Project teams.
- b. The PM should identify any LL or best practices applicable to the current effort by using the NEN LLIS, consulting with the GRC CKO Team, and/or contacting a NASA GRC librarian. Projects should use this information for planning, if appropriate, and during process before significant events. See Figure 3-3.
- c. As a best practice, the PM should formally plan to gather LL and conduct a workshop with all Project team members after each major project milestone review or after specific project phases. Capturing LL at various stages of the Project, particularly for larger Projects, can prove valuable in keeping the Project within budget, schedule, and technical scope. Collecting LL at the end of a project should be considered a minimum requirement.

## Appendix A. Definitions

**Acquisition.** The process for obtaining the systems, research, services, construction, and supplies that NASA needs to fulfill its missions. Acquisition—which may include procurement (contracting for products and services)—begins with an idea or proposal that aligns with the NASA Strategic Plan and fulfills an identified need and ends with the completion of the Project or the final disposition of the product or service.

**Acquisition Plan.** This plan documents an integrated acquisition strategy that enables a Project to meet its mission objectives and provides the best value to NASA. See Section 3.4 of The Project Plan Template (Appendix F) for detailed Instructions on Acquisition Plan.

**Approval (for implementation).** The acknowledgment by the DA that the Project has met stakeholder expectations and formulation requirements and is ready to proceed to implementation. By approving a Project, the DA commits the budget resources necessary to continue into implementation. Approval (for implementation) is documented.

**Baseline (document context).** This implies the expectation of a finished product, though updates may be needed, as circumstances warrant. All approvals required by Center policies and procedures have been obtained.

**Baseline (general context).** An agreed-to set of requirements, cost, schedule, designs, documents, and other project management products that will have changes controlled through a formal approval and monitoring process.

**Baseline Performance Review (BPR).** A monthly Agency-level independent assessment to inform senior leadership of performance and progress toward the Agency's mission and Project performance. The monthly meeting encompasses a review of cross-cutting mission support issues and all NASA mission areas.

**Budget.** A financial plan that provides a formal estimate of future revenues and obligations for a definite period for approved Projects, and activities. (See NPR 9420.1, Budget Formulation, and NPR 9470.1, Budget Execution, for other related financial management terms and definitions.)

**Center Management Council (CMC).** The council at a center that performs oversight of and Projects by evaluating all Project work executed at that center.

**Change Request.** A change to a prescribed requirement set forth in an Agency or Center document intended for all Projects for all time.

**Compliance Matrix.** The Compliance Matrix (Appendix C) documents whether and how the Project complies with the requirements of NPR 7120.5. It provides rationale and approvals for waivers from requirements and is part of retrievable Project documentation.

**Concept Documentation (formerly Mission Concept Report).** Documentation that captures and communicates a feasible concept that meets the goals and objectives of the mission, including results of analyses of alternative concepts, the concept of operations, preliminary risks, and potential descopes. It may include images, tabular data, graphs, and other descriptive material.

**Confidence level.** A probabilistic assessment of the level of confidence of achieving a specific goal.

**Configuration Management (CM).** A management discipline applied over the product’s life cycle to provide visibility into and control changes to performance, functional, and physical characteristics.

**Continuous risk management (CRM).** A systematic and iterative process that efficiently identifies, analyzes, plans, tracks, controls, communicates, and documents risks associated with the implementation of designs, plans, and processes.

**Contract.** A mutually binding legal relationship obligating the seller to furnish the supplies or services (including construction) and obligating the buyer to pay for them. It includes all types of commitments that obligate the Government to an expenditure of appropriated funds and that, except as otherwise authorized, are in writing. In addition to bilateral instruments, contracts include (but are not limited to) awards and notices of awards; job orders or Task letters issued under basic ordering agreements; letter contracts; orders, such as purchase orders, under which the contract becomes effective by written acceptance or performance; and bilateral contract modifications. Contracts do not include grants and cooperative agreements.

**Contract Performance Report.** Consists of five formats containing data for measuring a contractor’s cost and schedule performance on a government acquisition contract. This is a contract data requirement when EVM is required.

**Cost Analysis Data Requirement (CADRe).** A formal document designed to help managers understand the cost and cost risk of space flight Projects. The CADRe consists of Part A “Narrative” and Part B “Technical Data” in tabular form, both provided by the Project or Cost Analysis Division. Also, the Project team produces the Project life-cycle cost (LCC) estimate, schedule, and risk identification.

**Decision Authority (DA) (Project/Task context).** The individual authorized by the Agency to make important decisions on Projects under their authority.

**Decision Memorandum.** The document that summarizes the decisions made at KDPs or as necessary in between KDPs. The decision memorandum includes the Agency Baseline Commitment (if applicable), Management Agreement cost and schedule, UFE, and schedule margin managed above the project, as well as life-cycle cost and schedule estimates, as required. For single-project programs and projects that plan continuing operations and production, including integration of capability upgrades, with an unspecified Phase E end point, the initial capability cost plus the current Phase E cost estimate is used instead of the life-cycle cost.

**Decommissioning.** The process of ending an operating mission and the attendant Project because of a planned end of the mission or Project termination. Decommissioning includes final delivery of any remaining Project deliverables, disposal of the spacecraft and all its various supporting systems, closeout of contracts and financial obligations, and archiving of Project/mission operational and scientific data and artifacts. Decommissioning does not mean that scientific data analysis ceases, only that the Project will no longer provide the resources for continued research and analysis.

**Design documentation.** A document or series of documents that captures and communicates to others the specific technical aspects of a design. It may include images, tabular data, graphs, and other descriptive material. Design documentation is different from the CADRe, though parts of design documentation may be repeated in the latter.

**Development costs.** The total of costs from the period beginning with the approval to proceed to Implementation at the beginning of Phase C through operational readiness at the end of Phase D.

**Deviation.** A documented authorization releasing a Project from meeting a requirement *before* the requirement is put under configuration control at the level that the requirement will be implemented.

**Disposal.** The process of eliminating a project's assets, including the spacecraft and ground systems. Disposal includes the reorbiting, deorbiting, and/or passivation (i.e., the process of removing stored energy from a space structure at the end of mission that could result in an explosion or deflagration of the space structure) of a spacecraft.

**Earned Value Management (EVM).** A project management approach for measuring and assessing Project performance through the integration of technical scope with schedule and cost objectives during the execution of the Project. EVM provides quantification of technical progress, enabling management to gain insight into Project status and Project completion costs and schedules. Two essential characteristics of successful EVM are EVM system data integrity and carefully targeted monthly EVM data analyses (e.g., identification of risky WBS elements).

**Earned Value Management System (EVMS).** An integrated management system and its related subsystems that allow for planning all work scope to completion; assignment of authority and responsibility at the work performance level; integration of the cost, schedule, and technical aspects of the work into a detailed baseline plan; objective measurement of progress (earned value) at the work performance level; accumulation and assignment of actual costs; analysis of variances from plans; summarization and reporting of performance data to higher levels of management for action; forecast of achievement of milestones and completion of events; forecast of final costs; and disciplined baseline maintenance and incorporation of baseline revisions in a timely manner.

**Engineering Requirements.** Requirements defined to achieve programmatic requirements and relating to the application of engineering principles and best practices, design and construction standards, applied science, and industrial techniques.

**Environmental Impact.** The direct, indirect, or cumulative beneficial or adverse effect of an action on the environment.

**Evaluation.** The continual self- and independent assessment of the performance of a Project and incorporation of the evaluation findings to ensure adequacy of planning and execution according to plans.

**Final (document context).** This implies the expectation of a finished product. All approvals required by Center policies and procedures have been obtained.

**Formal Dissent.** A substantive disagreement with a decision or action that an individual judges is not in the best interest of NASA and is of sufficient importance that it warrants a timely review and decision by higher-level management.

**Formulation.** The identification of how the Project supports the Agency's strategic goals; the assessment of feasibility, technology, and concepts; risk assessment; team building; development of operations concepts and acquisition strategies; establishment of high-level requirements and success criteria; the preparation of plans, budgets, and schedules essential to the success of a Project; and the establishment of control systems to ensure performance to those plans and alignment with current Agency strategies.

**Formulation Agreement (FA).** The FA is prepared by the Project to establish the technical and acquisition work that needs to be conducted during Formulation and defines the schedule and funding requirements during Phase A and Phase B for that work.

**Formulation Authorization Document (FAD).** The document issued by the Mission Directorate Associate Administrator (MDAA) to authorize the formulation of a program whose goals will fulfill part of the Agency's Strategic Plan and Mission Directorate (MD) strategies and establish the expectations and constraints for activity in the formulation phase. In addition, a FAD or equivalent is used to authorize the formulation of a Project.

**Formulation Phase.** The first part of a program or project life cycle where Formulation activities are completed. The Formulation Phase begins at Approval for Formulation and ends at Approval for Implementation.

**Funding (budget authority).** The authority provided by law to incur financial obligations that will result in expenditures. There are four basic forms of budget authority, but only two are applicable to NASA: appropriations and spending authority from offsetting collections (reimbursables and working capital funds). Budget authority is provided or delegated to Projects through the Agency's funds distribution process.

**Health and Medical Requirements.** Requirements defined by the Office of the Chief Health and Medical Officer (OCHMO).

**Human Systems Integration.** A required interdisciplinary integration of the human as an element of the system to ensure that the human and software/hardware components cooperate, coordinate, and communicate effectively to perform a specific function or mission successfully.

**Implementation.** The execution of approved plans for the development and operation of the Project, and the use of control systems to ensure performance to approved plans and continued alignment with the Agency's strategic needs, goals, and objectives.

**Implementation Phase.** The second part of a program or project life cycle where Implementation activities are completed. The Implementation Phase begins at Approval for Implementation and continues through the end of the program or project.

**Independent assessment(s)** (includes reviews, evaluations, audits, analysis oversight, and investigations). Assessments are independent to the extent that the involved personnel apply their expertise impartially and without any conflict of interest or inappropriate interference or influence, particularly from the organization(s) being assessed.

**Industrial Base.** The capabilities residing in either the commercial or government sector required to design, develop, manufacture, launch, and service the program or project. This encompasses related manufacturing facilities, supply chain operations and management, a skilled workforce, launch infrastructure, research and development, and support services.

**Information technology (IT).** Any equipment or interconnected system or subsystem of equipment that is used in the automatic acquisition, storage, manipulation, management, movement, control, display, switching, interchange, transmission, or reception of data or information by an executive Agency. Information technology also includes computers; ancillary equipment (including imaging peripherals, input, output, and storage devices necessary for security and surveillance); peripheral equipment designed to be controlled by the central processing unit of a computer; software; firmware; and similar procedures, services (including support services), and related resources. It does not include any equipment acquired by a Federal contractor incidental to a Federal contract.

**Infrastructure requirements.** The facilities real property (buildings and/or other structures) and environmental, aircraft, personal property, collateral equipment, and associated system resources that are needed to support programs and projects. Utilization of the capability afforded by the

infrastructure includes consideration of the life-cycle cost (design, construction, commissioning, outfitting, special test equipment, utilities, operations and maintenance, and future disposal cost) and other liabilities it presents. The construction of real property infrastructure or the modification of existing infrastructure above a defined dollar amount must go through the Agency's Construction of Facilities account (CECR). (See NPR 8820.2, Facility Project Requirements and NPR 8800.15, Real Estate Management Program.)

**Initial Capability.** For single-project programs and projects that plan continuing operations and production, including integration of capability upgrades, with an unspecified Phase E end point, the initial capability is the first operational mission flight or as defined as part of the KDP B review plan. The scope of the initial capability is documented in the KDP B Decision Memorandum.

**Institutional authority.** Institutional authority encompasses all those organizations and authorities not in the programmatic authority. This includes engineering, Safety and Mission Assurance (SMA), and health and medical organizations; mission support organizations; and Center Directors.

**Institutional requirements.** Requirements that focus on how NASA does business that are independent of the particular Project. There are five types: Engineering, Project Management, Safety and Mission Assurance (SMA), Health and Medical, and Mission Support Office functional requirements.

**Integrated Baseline Review.** A risk-based review conducted by Project management to ensure a mutual understanding between the customer and supplier of the risks inherent in the supplier's Performance Measurement Baseline (PMB) and to ensure that the PMB is realistic for accomplishing all of the authorized work within the authorized schedule and budget.

**Integrated Center Management Council (ICMC).** The forum used by projects and programs that are being implemented by more than one Center and includes representatives from all participating Centers. The ICMC will be chaired by the director of the Center (or representative) responsible for program or project management.

**Integrated Logistics Support (ILS).** The management, engineering activities, analysis, and information management associated with design requirements definition, material procurement and distribution, maintenance, supply replacement, transportation, and disposal that are identified by space flight and ground systems supportability objectives.

**Integrated Master Schedule (IMS).** A logic network-based schedule that reflects the total Project scope of work, traceable to the Work Breakdown Structure (WBS), as discrete and measurable Tasks/milestones and supporting elements that are time-phased using valid durations based on available or Projected resources and well-defined interdependencies.

**Integrated Program Management Report.** The standard report format to communicate program/project monthly cost/schedule performance and status between a contractor and the Government. The IPMR consists of seven report formats that provide program/project managers information to: integrate cost and schedule performance data with technical performance measures, identify the magnitude and impact of actual and potential problem areas causing significant cost and schedule variances, forecast schedule completions, and provide valid, timely program/project status information to higher management for effective decision making. This is a contract data requirement when EVM is required.

**Integration Plan.** The integration and verification strategies for a Project interface with the system design and decomposition into the lower-level elements. The Integration Plan is structured to bring elements together to assemble each subsystem and to bring all the subsystems

together to assemble the system and/or product. The primary purposes of the Integration Plan are: (1) to describe this coordinated integration effort that supports the implementation strategy, (2) to describe for the participants what needs to be done in each integration step, and (3) to identify the required resources and when and where they will be needed.

**Interface Control Document (ICD).** An agreement between two or more parties on how interrelated systems will interface with each other. It documents interfaces between such things as electrical connectors (which type, how many pins, which signals will be on each pin, etc.), fluid connectors (type of connector, type of fluid being passed, flow rates of the fluid, etc.), mechanical (types of fasteners, bolt patterns, etc.), and any other interfaces that might be involved.

**Joint cost and schedule confidence level (JCL).** The probability that cost will be equal to or less than the targeted cost and schedule will be equal to or less than the targeted schedule date. The JCL calculation includes consideration of the risk associated with all elements, regardless of whether they are funded from appropriations or managed outside of the project (e.g., risk impacts of a foreign contribution behind schedule, risk impacts of the Launch Vehicle). JCL calculations include content from the milestone at which the JCL is calculated through the completion of Phase D activities. (See the NASA Cost Estimating Handbook for more information on JCL.)

**Key Decision Point (KDP).** The event at which the DA determines the readiness of a Project to progress to the next phase of the life cycle (or to the next KDP).

**Knowledge Management (KM).** Knowledge management is a multidisciplinary approach to sourcing and deploying knowledge assets for better work (individual and organizational) performance. It includes providing the knowledge worker the right information they need at the right time so that they can do their job well. Lessons Learned is a KM activity.

**Lessons Learned (LL).** Captured knowledge or understanding gained through experience which, if shared, would benefit the work of others. LL describes a specific event that occurred and provides recommendations for obtaining a repeat of success or for avoiding reoccurrence of an adverse work practice or experience.

**Life-cycle cost (LCC).** The total of the direct, indirect, recurring, nonrecurring, and other related expenses both incurred and estimated to be incurred in the design, development, verification, production, deployment, prime mission operation, maintenance, support, and disposal of a Project including closeout, but not extended operations. The LCC of a Project or system can also be defined as the total cost of ownership over the Project or system's planned life cycle from Formulation (excluding Pre-Phase A) through Implementation (excluding extended operations). The LCC includes the cost of the launch vehicle.

**Life-cycle review (LCR).** A review of a Project designed to provide a periodic assessment of the technical and programmatic status and health of a Project at a key point in the life cycle: that is, the Preliminary Design Review (PDR) or Critical Design Review (CDR). Certain LCRs provide the basis for the DA to approve or disapprove the transition of a Project at a Key Decision Point to the next life-cycle phase.

**Management Agreement.** Within the Decision Memorandum, the parameters and authorities over which the Project Manager (PM) has management control constitute the Project Management Agreement. A PM has the authority to manage within the Management Agreement and is accountable for compliance with the terms of the agreement.

**Margin.** The allowances carried in budget, projected schedules, and technical performance parameters (e.g., weight, power, or memory) to account for uncertainties and risks. Margins, which are allocated in the formulation process, are based on assessments of risks and are typically consumed as the Project proceeds through the life cycle.

**Metric.** A measurement taken over a period of time that communicates vital information about the status or performance of a system, process, or activity.

**Mission.** A major activity required to accomplish an Agency goal or to effectively pursue a scientific, technological, or engineering opportunity directly related to an Agency goal. Mission needs are independent of any particular system or technological solution.

**Non-Applicable Requirement.** Any requirement that is not relevant or not capable of being applied. The non-applicable requirement provision is intended to provide an efficient means to grant and document relief from a requirement not relevant or not capable of being applied to the specific mission. The need for relief from the requirement is obvious and the judgment of non-applicable is likely to be the same regardless of who makes the determination. For example, the requirement to produce a Human Rating Certification Package is non-applicable for a robotic project.

**Operations Concept Documentation.** A description of how the flight system and the ground system are used together to ensure that the concept of operation is reasonable. This might include how mission data of interest, such as engineering or scientific data, are captured, returned to Earth, processed, made available to users, and archived for future reference. The operations concept should describe how the flight system and ground system work together across mission phases for launch, cruise, critical activities, science observations, and end of mission to achieve the mission.

**Operations Handbook.** The Operations Handbook provides information essential to the operation of a spacecraft and other components of a mission. It generally includes a description of the spacecraft and other mission components and the operational support infrastructure; operational procedures, including step-by-step operational procedures for activation and deactivation; malfunction detection procedures; and emergency procedures. The handbook identifies the commands for the spacecraft and other mission components, defines the functions of these commands, and provides supplemental reference material for use by the operations personnel. The main emphasis is placed on command types, command definitions, command sequences, and operational constraints. Additional document sections may describe uploadable operating parameters, the telemetry stream data contents (for both the science and the engineering data), the Mission Operations System displays, and the spacecraft and other mission component health monitors.

**Orbital debris.** Any object placed in space by humans that remains in orbit and no longer serves any useful function. Objects range from spacecraft to spent launch vehicle stages to components and include materials, trash, refuse, fragments, and other objects that are overtly or inadvertently cast off or generated.

**Performance Measurement Baseline (PMB).** The time-phased cost plan for accomplishing all authorized work scope in a Project's life cycle, which includes both NASA internal costs and supplier costs. The Project's performance against the PMB is measured using EVM, if required, or other performance measurement techniques, if EVM is not required. It is formed by the budgets assigned to scheduled CAs and the applicable indirect budgets. For future effort, not

planned to the CA level, the PMB also includes budgets assigned to higher level WBS elements and undistributed budgets. The PMB does not include Unallocated Future Expenses (UFEs).

**Preliminary (document context).** Implies that the product has received initial review in accordance with Center best practices. The content is correct, though some to be determined (TBD) items may remain. All approvals required by Center policies and procedures have been obtained. Major changes are expected.

**Prescribed requirement.** A requirement levied on a lower organizational level by a higher organizational level.

**Principal Investigator (PI).** A person who conceives an investigation and is responsible for carrying it out and reporting its results. In some cases, PIs from industry and academia act as Project Managers (PMs) for smaller development efforts with NASA personnel providing oversight.

**Procurement Strategy Meeting (PSM).** A forum where management reviews and approves the approach for the Agency's major and other selected procurements. Chaired by the Assistant Administrator for Procurement (or designee), the PSM addresses and documents information, activities, and decisions required by the Federal Acquisition Regulation (FAR) and NASA FAR Supplement (NFS) and incorporates NASA strategic guidance and decisions from the Acquisition Strategy Meeting (ASM) to ensure the alignment of the individual procurement action with NASA's portfolio and mission.

**Program.** A strategic investment by a Mission Directorate (MD) or Mission Support Office that has a defined architecture and/or technical approach, requirements, funding level, and management structure that initiates and directs one or more Projects. A program defines a strategic direction that the Agency has identified as critical.

**Program Plan.** The document that establishes the program's baseline for implementation, signed by the Mission Directorate Associate Administrator (MDAA), Center Director(s), and Program Manager.

**Programmatic authority.** Programmatic authority includes the Mission Directorates (MDs) and their respective Program and Project Managers (PMs). Individuals in these organizations are the official voices for their respective areas. Programmatic authority sets, oversees, and ensures conformance to applicable programmatic requirements.

**Programmatic requirements.** Requirements set by the Mission Directorate (MD), program, Project, and Principal Investigator (PI), if applicable. These include strategic, scientific, and exploration requirements; system performance requirements; safety requirements; and schedule, cost, and similar nontechnical constraints.

**Project.** A specific investment identified in a Program Plan (PP) having defined requirements, a life-cycle cost (LCC), a beginning, and an end. A Project also has a management structure and may have interfaces to other Projects, agencies, and international partners. A Project yields new or revised products that directly address NASA's strategic goals. For GRC, Project is additionally defined in Section P.2 as: A funded effort that has been assigned to GRC to *lead*. These are typically Level III Projects as per the standard NASA programmatic structure shown in Figure P.

**Project Management Requirements.** Requirements that focus on how NASA and centers perform Project management activities.

**Project Plan.** The document that establishes the Project’s baseline for implementation, signed by the responsible Program Manager, Center Director, Project Manager (PM), and the Mission Directorate Associate Administrator (MDAA), if required.

**Project Protection Plan.** This plan is based on threat summaries that document the threat environment that a NASA space system, space constellation, or aircraft is most likely to encounter as it reaches operational capability.

**Project team.** All participants in Project formulation and implementation. This includes all direct reports and others that support meeting Project responsibilities.

**Rebaselining.** The process that results in a change to a Project’s Agency Baseline Commitment (ABC).

**Reimbursable project.** A Project (including work, commodities, or services) for customers other than NASA for which reimbursable agreements have been signed by both the customer and NASA. The customer provides funding for the work performed on their behalf.

**Replanning.** The process by which a program or project updates or modifies its plans.

**Request for Action/Review Item Discrepancy.** The most common names for the comment forms that reviewers submit during life-cycle reviews that capture their comments, concerns, and/or issues about the product or documentation.

**Risk.** In the context of mission execution, risk is the potential for performance shortfalls that may be realized in the future with respect to achieving explicitly established and stated performance requirements. The performance shortfalls may be related to any one or more of the following mission execution domains: (1) safety, (2) technical, (3) cost, and (4) schedule. (See NPR 8000.4, “Agency Risk Management Procedural Requirements.”)

**Risk assessment.** An evaluation of a risk item that determines: (1) what can go wrong, (2) how likely is it to occur, (3) what the consequences are, (4) what the uncertainties are that are associated with the likelihood and consequences, and (5) what the mitigation plans are.

**Risk-Informed Decision Making (RIDM).** An RIDM process uses a diverse set of performance measures (some of which are model-based risk metrics) along with other considerations within a deliberative process to inform decision making.

**Risk-Informed Probabilistic Analysis.** Analysis informed by all appropriate discrete risks and uncertainties including those that may not be discretely managed in the risk management system.

**Risk management.** Risk management includes Risk-Informed Decision Making (RIDM) and Continuous Risk Management (CRM) in an integrated framework. RIDM informs systems engineering decisions through the better use of risk and uncertainty information in selecting alternatives and establishing baseline requirements. CRM manages risks over the course of the development and the implementation phase of the life cycle to ensure that safety, technical, cost, and schedule requirements are met. This is done to foster proactive risk management, to better inform decision making through better use of risk information, and then to manage implementation risks more effectively by focusing the CRM process on the baseline performance requirements emerging from the RIDM process. (See NPR 8000.4.) These processes are applied at a level of rigor commensurate with the complexity, cost, and criticality of the program.

**Safety.** Freedom from those conditions that can cause death, injury, occupational illness, damage to or loss of equipment or property, or damage to the environment.

**Safety and Mission Assurance (SMA) Requirements.** Requirements defined by the SMA organization related to safety and mission assurance.

**Security.** Protection of people, property, and information assets owned by NASA that covers physical assets, personnel, information technology (IT), communications, and operations.

**Signature.** A distinctive mark, characteristic, or thing that indicates identity; one's name as written by oneself.

**Standards.** Formal documents that establish a norm, requirement, or basis for comparison; a reference point to measure or evaluate against. A technical standard, for example, establishes uniform engineering or technical criteria, methods, processes, and practices. (Refer to NPR 7120.10, "Technical Standards for NASA Programs and Projects.")

**Stakeholder.** An individual or organizational customer having an interest (or stake) in the outcome or deliverable of a program or project.

**Standing Review Board (SRB).** The board responsible for conducting independent reviews (life cycle and special) of a Project and providing objective, expert judgments to the convening authorities. The reviews are conducted in accordance with approved Terms of Reference (TORs) and life-cycle requirements, per NPR 7120.5 and NPR 7123.1, "NASA Systems Engineering Processes and Requirements." (See NASA/SP—2013-02-026-HQ for additional details.)

**Success criteria.** That portion of the top-level requirements that defines what is to be achieved to successfully satisfy NASA Strategic Plan objectives addressed by the Project.

**Suppliers.** Each project office is a customer having a unique, multi-tiered hierarchy of suppliers to provide it products and services. A supplier may be a contractor, grantee, another NASA center, university, international partner, or other Government agency. Each Project supplier is also a customer if it has authorized work to a supplier lower in the hierarchy.

**Supply chain.** The specific group of suppliers and their interrelationships that are necessary to design, develop, manufacture, launch, and service the Project. This encompasses all levels within a space system, including providers of raw materials, components, subsystems, systems, systems integrators, and services.

**System.** The combination of elements that function together to produce the capability required to meet a need. The elements include all hardware, software, equipment, facilities, personnel, processes, and procedures needed for this purpose.

**Systems engineering.** Per NPR 7123.1, NASA systems engineering is a logical systems approach performed by multidisciplinary teams to engineer and integrate NASA's systems to ensure NASA products meet the customer's needs. Implementation of this systems approach will enhance NASA's core engineering capabilities while improving safety, mission success, and affordability. This systems approach is applied to all elements of a system (i.e., hardware, software, and human) and all hierarchical levels of a system over the complete program/project life cycle.

**Tailoring.** The process used to adjust or seek relief from a prescribed requirement to accommodate the needs of a specific Task or activity (e.g., Project). The tailoring process results in the generation of deviations and waivers depending on the timing of the request.

**Task.** A funded effort that is performed in support of another NASA center or other organization, such as a partnering federal agency or a reimbursing industry partner. See Section P.2.

**Technical Authority (TA).** Part of NASA’s system of checks and balances that provides independent oversight of programs and Projects in support of safety and mission success through the selection of individuals at delegated levels of authority. These individuals are the TAs. TA delegations are formal and traceable to the Administrator. Individuals with technical authority are funded independently of a Project.

**Technical Authority Requirements.** Requirements invoked by OCE, OSMA, and Office of the Chief Health and Medical Officer (OCHMO) documents (e.g., NPRs or technical standards cited as program or project requirements) or contained in Center institutional documents. These requirements are the responsibility of the office or organization that established the requirement unless delegated elsewhere.

**Technical standard.** Common and repeated use of rules, conditions, guidelines, or characteristics for products or related processes, and production methods and related management systems practices; the definition of terms, the classification of components; the delineation of procedures; the specification of dimensions, materials, performance, designs, or operations; the measurement of quality and quantity in describing materials, processes, products, systems, services, or practices; test methods and sampling procedures; or descriptions of fit and measurements of size or strength. (Source: Office of Management and Budget Circular No. A-119, “Federal Participation in the Development and Use of Voluntary Consensus Standards and in Conformity Assessment Activities”) (See NPR 7120.10.)

**Technology Readiness Level (TRL).** Provides a scale against which to measure the maturity of a technology. TRLs range from 1, Basic Technology Research, to 9, Systems Test, Launch, and Operations. Typically, a TRL of 6 (i.e., technology demonstrated in a relevant environment) is required for a technology to be integrated into a flight system. (See NASA Systems Engineering Handbook NASA/SP-2007-6105 Rev. 1, p. 296 for more information on TRL levels and technology assessment, and SP-20205003605, Technology Readiness Assessment Best Practices Guide.)

**Termination Review.** A review initiated by the DA for the purpose of securing a recommendation as to whether to continue or terminate a program or project. Failing to stay within the parameters or levels specified in controlling documents will result in consideration of a termination review. (See NASA/SP-2014-3705, NASA Space Flight Program and Project Management Handbook for information on a Termination Review.)

**Terms of reference.** A document specifying the nature, scope, schedule, and ground rules for an independent review or independent assessment.

**Unallocated Future Expenses (UFE).** The portion of estimated cost required to meet a specified confidence level that cannot yet be allocated to the specific Project Work Breakdown Structure (WBS) sub elements because the estimate includes probabilistic risks and specific needs that are not known until these risks are realized.

**Validation.** The process of showing proof that the product accomplishes the intended purpose, based on stakeholder expectations. Validation may be determined by a combination of test, analysis, demonstration, and inspection. (Validation answers the question: “Am I building the right product?”)

**Verification.** Proof of compliance with requirements. Verification may be determined by a combination of test, analysis, demonstration, and inspection. (Verification answers the question: “Did I build the product right?”)

**Waiver.** A documented authorization releasing a Project from meeting a requirement *after* the requirement is put under configuration control at the level the requirement will be implemented.

**Work Breakdown Structure (WBS).** A product-oriented hierarchical division of the hardware, software, services, and data required to produce the Project's end product(s), structured according to the way the work will be performed, and reflecting the way in which Project costs and schedule, technical, and risk data are to be accumulated, summarized, and reported.

## **APPENDIX B. Acronyms**

ABC	Agency Baseline Commitment
ATD	Advanced Technology Development
AES	Advanced Exploration Systems
AMPS	AES Modular Power Systems
ANSI	American National Standards Institute
AO	Announcement of Opportunity
ARRM-SEP	Asteroid Rendezvous and Redirect Mission—Solar Electric Propulsion
ASM	Acquisition Strategy Meeting
ASRG	Advanced Stirling Radioisotope Generator
ATD	Advanced Technology Development
ATP	Authority to Proceed
BMS	Business Management System
BOBJ	Business Objects
BOE	Basis of Estimate
BPR	Baseline Performance Review
CA	Control Account
CAD	Cost Analysis Division
C&DH	Command and Data Handling
CAM	Control Account Manager
CD	Center Director
CDA	Center Direct Assessments
C/DM	Configuration/Data Manager
CDR	Critical Design Review
CE	Chief Engineer
CER	Center Export Representative
CFO	Chief Financial Officer
CKO	Chief Knowledge Officer
CM	Configuration Management
CMC	Center Management Council
CO	Contracting Officer
CoF	Construction of Facilities
COI	Conflict of Interest

CoNNeCT	Communication, Navigation & Networking Reconfigurable Test bed
COOP	Continuity of Operations
COR	Contracting Officer's Representative
CPAR	Corrective and Preventative Action Reporting
CPST	Cryogenic Propellant Storage & Transfer
CRM	Continuous Risk Management
CS	Civil Servant
CSO	Chief Safety and Mission Assurance Officer
CT	Chief Technologist
C&T	Communication and Tracking
DA	Decision Authority
DLE	Discipline Lead Engineer
DPM	Deputy Project Manager
DW	Deviation and Waiver
EAR	Export Administration Regulations
ECLSS	Environmental Control and Life Support Subsystem
ECP	Export Control Program
EEE	Electrical, Electronic, and Electromechanical
ELV	Expendable Launch Vehicle
EMB	Engineering Management Board
EMD	Environmental Management Division
EMS	Environmental Management System
ePMS	Enterprise Project Management System
ERB	Engineering Review Board
ESA	External Support Agreement
ETA	Engineering Technical Authority
EVA	Extravehicular Activity
EVM	Earned Value Management
EVMS	Earned Value Management System
FA	Formulation Agreement
FAD	Formulation Authorization Document
FAR	Federal Acquisition Regulation
FCF	Fluids and Combustion Facility
FD	Facilities Infrastructure Division

FRR	Flight Readiness Review
FS&GS	Flight Systems and Ground Support
FTE	Full Time Equivalent (civil service labor)
FY	fiscal year
GDS	Ground Data System
GLID	Glenn Interim Directive
GLP	Glenn Procedure
GLPD	Glenn Policy Directive
GLPR	Glenn Procedural Requirement
GLWI	Glenn Work Instruction
GN&C	Guidance, Navigation, and Control
GRC	Glenn Research Center
GSE	Ground Support Equipment
HEA	NASA Headquarters Export Administrator
HQ	NASA Headquarters
HRP	Human Research Program
IBR	Integrated Baseline Review
ICA	Independent Cost Assessment
ICD	Interface Control Document
ICE	Independent Cost Estimate
ICMC	Integrated Center Management Council
ID	Identification
ILS	Integrated Logistics Support
IM	Integration Manager
IMS	Integrated Master Schedule
ISPT	In-Space Propulsion Technology
IT	Information Technology
ITAR	International Traffic in Arms Regulations
JCL	Joint Cost and Schedule Confidence Level
KDP	Key Decision Point
KPP	Key Performance Parameter
KM	Knowledge Management
LCC	Life-Cycle Cost
LCR	Life-Cycle Review

LL	Lessons Learned
LLIS	Lessons Learned Information System
LMM	Light Microscopy Module
LPMO	Logistics and Property Management Office
LSE	Lead Systems Engineer
MCR	Mission Concept Review
MD	Mission Directorate
MDAA	Mission Directorate Associate Administrator
MDCA	Multi-user Droplet Combustion Apparatus
MDR	Mission Definition Review
MDS	Mission Directorate Support
MOS	Mission Operations System
MOU	Memorandum of Understanding
MRB	Material Review Board
MRR	Mission Readiness Review
MS	Microsoft
MSC	Mission Support Council
N/A	Not Applicable
NASA/SP	NASA Special Publication
NASA STD	NASA Technical Standard
NCR	Non-Conformance Report
NEN	NASA Engineering Network
NEPA	National Environmental Policy Act
NF	NASA Form
NFS	NASA FAR Supplement
NOA	New Obligation Authority
NODIS	NASA On-Line Directives Information System
NPD	NASA Policy Directive
NPR	NASA Procedural Requirements
OBR	Operations Board Review
OBS	Organizational Breakdown Structure
OCE	Office of the Chief Engineer
OCFO	Office of the Chief Financial Officer
OCIO	Office of the Chief Information Officer

ODAR	Orbital Debris Assessment Report
ODC	Other Direct Costs
OMB	Office of Management and Budget
OPS	Office of Protective Services
ORR	Operational Readiness Review
OSMA	Office of Safety and Mission Assurance
PAA	Program Analysis and Alignment
PaIG	Programmatic and Institution Guidance
PBC	Performance-Based Contractor
PBS	Product Breakdown Structure
PCB	Project Control Board
PDA	Program Direct Assessment
PDR	Preliminary Design Review
PI	Principal Investigator
PIR	Program Implementation Review
PLE	Product Lead Engineer
PM	Project Manager
PMB	Performance Measurement Baseline
PMBOK	Guide to the Project Management Body of Knowledge
PMC	Program Management Council
PO	Project Office
POIC	Payload Operations Integration Center
PP	Project Plan
PP&C	Project Planning and Control
PPBE	Planning, Programming, Budgeting, and Execution
PPCO	Program Planning & Control Office
PR	Purchase Requisition
PRB	Project Review Board
PRD	Project Requirements Document
PRG	Program and Resource Guidance
PSM	Procurement Strategy Meeting
PSR	Pre-Ship Review
RA	Resource Analyst
RFA	Request for Action

RFP	Request for Proposal
RID	Review Item Discrepancy
RIDM	Risk-Informed Decision Making
RLS	Resource Loaded Schedule
RMB	Risk Management Board
RMIT	Risk Management Implementation Tool
RPS	Radioisotope Power Systems
RRAA	Responsibilities, Authorities and Accountabilities
SAA	Space Act Agreement
SAR	System Acceptance Review
SCaN	Space Communications and Navigation
SDR	System Definition Review
SEI	Software Engineering Institute
SE&I	Systems Engineering and Integration
SEMP	Systems Engineering Management Plan
SFS	Space Flight Systems
SI	Système Internationale (or metric) system of measurement
SID	Strategic Investments Division
SIR	System Integration Review
SLA	Service Level Agreement
SLS	Space Launch System
SMA	Safety and Mission Assurance
SMAP	Safety and Mission Assurance Plan
SMB	Safety and Mission Assurance Management Board
SMD	Science Mission Directorate
SMSR	Safety and Mission Success Review
SOW	Statement of Work
SPG	Strategic Planning Guidance
SRA	Schedule Risk Analysis
SRB	Standing Review Board
SRD	System Requirements Document
SRP	Standard Repair Procedure
SRR	System Requirements Review
SSC	Support Service Contractor

SSMLI	Self-Supporting Multilayer Insulation
STMD	Space Technology and Mission Directorate
TA	Technical Authority
TAA	Technical Assistance Agreement
TBD	To Be Determined
TBR	To Be Resolved
TOR	Terms of Reference
TRL	Technology Readiness Level
UFE	Unallocated Future Expenses
V&V	Verification and Validation
WBS	Work Breakdown Structure
WYE	Work Year Equivalent (contractor labor)

# APPENDIX C. Project Compliance Matrix and Instructions

---

## C.1 Compliance Matrix and Tailoring

Compliance Matrix options have been developed to facilitate the tailoring process. Projects may use the full Compliance Matrix, or, if applicable, a pre-customized Compliance Matrix template, or a pre-approved Blanket Tailoring Compliance Matrix. (See Agency Tailoring Web site, <https://appel.nasa.gov/npr-7120-5-tailoring-resources>, for examples of these Compliance Matrices and templates.) The project manager should coordinate with the program or the Mission Directorate, respectively, to select and obtain the appropriate approval for using a Compliance Matrix other than the full Compliance Matrix. See NPR 7120.5, Appendix C.1 for details.

## C.2 Template Instructions

- a. This Compliance Matrix documents the GRC Project’s compliance with the requirements of NPR 7120.5 and this GLPR. A Microsoft (MS) Word Project Compliance Matrix Template can be found in the GRC Business Management System (BMS) **Library > Center Templates > Engineering/Program and Project Templates**.
  - (1) NPR 7120.5, paragraph reference, and/or GLPR 7120.5.10, paragraph reference.
  - (2) Requirement statement from NPR 7120.5, requirement statement, and/or the GLPR 7120.5.10 requirement statement.
  - (3) The requirement owner (the organization or individual responsible for the requirement).
  - (4) The tailoring authority (when permitted).

*Note: The organization at the level that established the requirement dispositions the request for the tailoring of that requirement unless this authority has been formally delegated elsewhere.*
  - (5) The organization or individual to whom the requirement applies (e.g., the Center Director (CD) or Project Manager (PM)).
  - (6) A “Comply?” column to describe the applicability or intent to tailor.
  - (7) The “Justification” column to justify how tailoring will be applied or why it does not apply.
  - (8) The “Approval” column when signatures are required for approval of tailoring.
- b. The “Requirement Owner” column designates which organization is responsible for maintaining the requirement for the Agency. The head of the requirement owner’s organization has the authority for tailoring unless this authority has been formally delegated. An “X” in the “Tailor” column indicates that the NASA Headquarters (HQ) requirements owner has retained approval authority for the tailoring of the requirement. When there is no “X” in the “Tailor” column, tailoring authority may have been delegated by the responsible organization. In this case, PMs should work with the Center representative of the responsible organization (e.g., the Office of Safety and Mission Assurance (OSMA)) to determine if tailoring authority has been delegated to a Center person and, if so, who is the delegated authority. Note that Office of the Chief Engineer (OCE) delegations can be found in the

“Letter of Delegation” located on the OCE tab under the “Other Policy Documents” menu in the NASA On-Line Directives Information System (NODIS).

- c. The next three columns (“MDAA,” “CD,” and “PM”) designate to whom the requirement applies. An “A” in the column indicates applicability.
- d. The “Comply?” column is filled in by the Project to identify the Project’s approach to the requirement. The Project inserts an “FC” for “fully compliant,” “T” for “tailored,” or “NA” for a requirement that is “not applicable.” The column titled “Justification” documents the rationale for tailoring, how the requirement will be tailored, or justifies why the requirement is not applicable. It is expected that much of the rationale will already have been developed in retrievable program and/or Project records and can simply be referenced (in an appropriate, accessible form). The level of documentation should be commensurate with the significance of departure from the norm and is determined by the requirements owner or as delegated. In the case where evaluation indicates that the tailoring of a requirement increases risk, evidence of official acceptance of that risk should be provided as referenced in retrievable program or Project records. Columns in the Compliance Matrix can be adjusted to accommodate the necessary information.
- e. For tailored requirements, the name, title, and signature of the responsible authority (requirement owner or delegate) goes in the “Approval” column to indicate that approval to tailor has been obtained from the head of the organization responsible for the requirement (or as delegated) with any required concurrences. The requirement owner consults with the other organizations that were involved in the establishment of the specific requirement and obtains the concurrence of those organizations having a substantive interest. The Compliance Matrix is submitted as part of the FA or PP. Redundant signatures are not required in the “Approval” column of the Compliance Matrix, if the requirements owner is already a required signatory (e.g., the Center Director (CD), Program Manager, and PM) on the FA or PP. An example of this would be OCE requirements that have been delegated to the CD (as designated by a blank in the “Tailor” column and the “Letter of Delegation”). In this case, a separate signature by the CD is not required in the “Approval” column because the CD is a signatory on the plan. However, if tailoring was proposed for a requirement by an owner who is not normally a signatory on the FA or PP (e.g., OSMA), the PM should obtain the signature of the approving official in the “Approval” column of the Compliance Matrix prior to submitting the plan for final signature.
- f. The Compliance Matrix in this appendix has been modified to include the additional GRC requirements and to gray-out those requirements from the Compliance Matrix in NPR 7120.5 that do not apply to GRC. Some requirements may be prepopulated as they pertain to GRC institutional structures already in place to support the Projects (i.e., GRC Business Management System (BMS) directives).
- g. The Compliance Matrix is provided to streamline the waiver and deviation process described in paragraph 3.5 of NPR 7120.5. If the Compliance Matrix is completed in accordance with these instructions, it meets the requirements for requesting tailoring and serves as a group submittal for waivers to NPR 7120.5. Once the FA or PP is signed, the tailoring is approved. A copy is forwarded to OCE. If the Compliance Matrix changes or if compliance is phased for existing Projects, updated versions of the Compliance Matrix are incorporated into an approved FA or PP revision.

### C.3 Approver Acronyms

Approver acronyms and symbols are defined below. All other acronyms used in the Compliance Matrix are defined in Appendix B of this GLPR.

CAD	Cost Analysis Division
EMD	Environmental Management Division
FD	Facilities Infrastructure Division
MDAA	Mission Directorate Associate Administrator
OCE	Office of the Chief Engineer
OCFO	Office of the Chief Financial Officer
OCIO	Office of the Chief Information Officer
OComm	Office of Communications
OE	Office of Education
OIIR	Office of International and Interagency Relations
OPS	Office of Protective Services
OSMA	Office of Safety and Mission Assurance
SMD	Science Mission Directorate

X = Headquarters' requirements owner has retained approval authority for tailoring of the requirement.

A = Applicability

## C.4 Compliance Matrix Template

**[Project Name]**

Number	NPR 7120.5F Paragraph no.	GLPR 7120.5.10 Paragraph no.	GLPR 7120.5.10/NPR 7120.5F, Requirement Statement	Requirement Owner	Delegated	MDAA	CD	PM	Comply?	Justification	Approval
1		2.3.2	During the initialization of a Project/Task, the PM <b>shall</b> identify the internal GRC classification that is deemed appropriate based on the criteria and classes given in Table 2.1. All Projects/Tasks managed by SFS will use this classification system, unless otherwise directed by the authorizing MD, Program Office, or lead center Project. For additional guidance see Section 3.4.								
2		2.3.3	For Projects led by GRC, the proposed Project classification, including governance approval authority and management reporting cadence, <b>shall be</b> documented in the Project/Task Scope Summary document at the start of Formulation phase, and in the PP at the start of Implementation phase, for approval by the appropriate management authority. For additional guidance see Section 3.4.								
3		2.3.4	When GRC is assigned an SFS Task for a Project led by another organization, the PM <b>shall</b> negotiate an agreement with the lead PM which outlines the governance hierarchy in relation to GRC Project management requirements. For guidance see Section 3.10.								
4		2.5.a	The PM <b>shall</b> provide a recommended technical, budget, and schedule performance baseline for the Project/Task to the governing authority for approval in support of the annual budget cycle, at a minimum, and at other key points in the Project/Task life cycle, such as when entering milestone reviews and at KDPs. For guidance see Section 3.4.								
5		2.5.b	The PM <b>shall</b> manage and control the Project/Task technical, budget, and schedule performance baseline during execution using a PCB, or equivalent. For guidance see Section 3.21.								
6		2.5.c	Each GRC Project and Task, as represented by the PM, <b>shall</b> periodically report the status of technical, budget, and schedule performance against plans to the appropriate GRC management authority. For guidance see Section 3.23.								
7		2.5.d	The PM <b>shall</b> plan for and follow appropriate closeout procedures and best practices at the completion of the Project/Task to ensure an orderly shutdown and archiving of assets. For guidance see Section 3.27.								
8		2.6.1.a	Each Project <b>shall</b> complete and attach a Compliance Matrix (See Appendix C) to the FA for Projects in Formulation or to the PP when Projects reach Implementation. For guidance see Appendix C.1.	SFS Dir. Or Center Deputy Dir.							
9		2.7.a	GRC Projects and Tasks, as represented by the PM, <b>shall</b> follow the TA and Formal Dissent processes established in GLPLN 1120.1, "Technical Authority Implementation Plan." For guidance see Sections 3.21 and 3.26.	SFS Dir. Or Center Deputy Dir.							
10	2.1.1.2		Regardless of the structure of a Project meeting the criteria of Section P.2, this NPR <b>shall</b> apply to the full scope of the Project and all the activities under it.	OCE	No			A			
11	2.1.3.1		Projects are Category 1, 2, or 3 and <b>shall</b> be assigned to a category based initially on: (1) the project life-cycle cost (LCC) estimate, the inclusion of significant radioactive material, and whether or not the system being developed is for human space flight; and (2) the priority level, which is related to the importance of the activity to NASA, the extent of international participation (or	OCE	No	A					

Number	NPR 7120.5F Paragraph no.	GLPR 7120.5.10 Paragraph no.	GLPR 7120.5.10/NPR 7120.5F, Requirement Statement	Requirement Owner	Delegated	MDAA	CD	PM	Comply?	Justification	Approval
			joint effort with other government agencies), the degree of uncertainty surrounding the application of new or untested technologies, and spacecraft/payload development risk classification.								
12	2.1.3.2		For Category 1 projects, the assignment of a project to a Center or implementing organization <b>shall</b> be with the concurrence of the NASA AA.	OCE	No	A					
13	2.1.4.1		Projects with a LCC or initial capability cost greater than \$250M <b>shall</b> be managed by program and project managers who have been certified in compliance with Office of Management and Budget (OMB)'s promulgated Federal acquisition program/project management certification requirements.	OCE	No	A					
14	2.2.1		Projects <b>shall</b> follow their appropriate life cycle, which includes life-cycle phases; life-cycle gates and major events, including KDPs; major LCRs; principal documents that govern the conduct of each phase; and the process of recycling through Formulation when program changes warrant such action. <b>For guidance see Sections 3.4, 3.10, and 3.25.</b>	OCE	Yes			A			
15	2.2.2		Project managers <b>shall</b> organize the work required for each phase using a product-based WBS developed in accordance with the Project Plan template. <b>For guidance see Section 3.7 and Appendix F.</b>	OCE	Yes			A			
16	2.2.3		The documents shown on the life-cycle figures and described below <b>shall</b> be prepared in accordance with the templates in Appendices D, E, F, G, and H of NPR 7120.5F. <b>For guidance see Appendices C.1, E, and F.</b>	OCE	Yes			A			
17	2.2.4		Each Project <b>shall</b> perform the LCRs identified in its respective figure in accordance with NPR 7123.1, applicable Center practices, and the requirements of this NPR 7120.5F. <b>For guidance see Section 3.25.</b>	OCE	Yes			A			
18	2.2.5		The Project and an independent Standing Review Board (SRB) <b>shall</b> conduct the SRR, SDR/MDR, PDR, CDR, SIR, ORR, and Program Implementation Review (PIR) LCRs. <b>For guidance see Section 3.25.</b>	OCE	No			A			
19	2.2.5.1		The Conflict of Interest (COI) procedures detailed in the NASA Standing Review Board Handbook <b>shall</b> be strictly adhered to. <b>For guidance see Section 3.25.</b>	OCE	No	A	A	A			
20	2.2.5.2		The portion of the LCR conducted by the SRB <b>shall</b> be convened by the Convening Authorities in accordance with NPR 7120.5F Table 2.2. <b>For guidance see Section 3.25.</b>	OCE	No	A	A	A			
21	2.2.5.3		The PM, the SRB Chair, and the Center Director (or designated Engineering TA representative) <b>shall</b> mutually assess the Project's expected readiness for the LCR and report any disagreements to the DA for final decision. <b>For guidance see Sections 2.2, 3.23, and 3.25.</b>	OCE	No		A	A			
22	2.2.6		In preparation for these LCRs, Project <b>shall</b> generate the appropriate documentation per NPR 7120.5F, NPR 7123.1, and Center practices, as necessary, to demonstrate that the Project's definition and associated plans are sufficiently mature to execute the follow-on phase(s) with acceptable technical, safety, and programmatic risk. <b>For guidance see Sections 2.2, 3.12, 3.23, and 3.25.</b>	OCE	No			A			
23	Table I-4		1. Concept Documentation [Approve at MCR]. [Required per NPR 7123.1] <b>For guidance see Section 2.6 and Appendix C.1.</b>	OCE	Yes			A			

Number	NPR 7120.5F Paragraph no.	GLPR 7120.5.10 Paragraph no.	GLPR 7120.5.10/NPR 7120.5F, Requirement Statement	Requirement Owner	Delegated	MDAA	CD	PM	Comply?	Justification	Approval
24	Table I-4		2. Mission, Spacecraft, Ground, and Payload Architectures [Baseline mission and spacecraft architecture at SRR; Baseline ground and payload architectures at SDR/MDR]. [Required per NPR 7123.1] <i>For guidance see Section 2.6 and Appendix C.1.</i>	OCE	Yes			A			
25	Table I-4		3. Project-Level, System, and Subsystem Requirements [Baseline Project-level and system-level requirements at SRR; Baseline subsystem requirements at PDR]. [Required per NPR 7123.1] <i>For guidance see Section 2.6 and Appendix C.1.</i>	OCE	Yes			A			
26	Table I-4		4. Design Documentation [Baseline preliminary design at PDR; Baseline detailed design at CDR; Baseline as-built hardware and software at MRR/FRR]. [Required per NPR 7123.1] <i>For guidance see Section 2.6 and Appendix C.1.</i>	OCE	Yes			A			
27	Table I-4		5. Operations Concept [Baseline at PDR]. [Required per NPR 7120.5 Appendix F FA Template] <i>For guidance see Section 2.6 and Appendix C.1.</i>	OCE	Yes			A			
28	Table I-4		6. Technology Readiness Assessment Documentation. [Required per NPR 7120.5 Appendix F FA Template] <i>For guidance see Section 2.6 and Appendix C.1.</i>	OCE	Yes			A			
29	Table I-4		7. Engineering Development Assessment Documentation. [Required per NPR 7120.5 Appendix F FA Template] <i>For guidance see Section 2.7 and Appendix C.1.</i>	OCE	Yes			A			
30	Table I-4		8. Heritage Assessment Documentation. [Required per NPR 7120.5 Appendix F FA Template] <i>For guidance see Section 2.8 and Appendix C.1.</i>	OCE	Yes			A			
31	Table I-4		9. Safety Data Packages [Baseline at CDR] [Required per NPR 8715.7]. <i>For guidance see Section 2.6 and Appendix C.1.</i>	OSMA	Yes			A			
32	Table I-4		10. ELV Payload Safety Process Deliverables [Baseline at SIR] [Required per NPR 8715.7]. <i>For guidance see Section 2.6 and Appendix C.1.</i>	OSMA	Yes			A			
33	Table I-4		11. Verification and Validation Report [Baseline at MRR/FRR]. [Required per NPR 7123.1] <i>For guidance see Section 2.6 and Appendix C.1.</i>	OCE	Yes			A			
34	Table I-4		12. Operations Handbook [Baseline at ORR]. <i>[additional information in NASA-STD-8719, App, B]</i> <i>For guidance see Section 2.6 and Appendix C.1.</i>	OCE	Yes			A			
35	Table I-4		13. Orbital Debris Assessment [Required per NPR 8715.6] [Final Orbital Debris Assessment Report (ODAR) at SMSR]. <i>For guidance see Section 2.6 and Appendix C.1.</i>	OSMA	No			A			
36	Table I-4		14. End of Mission Plans [Required per NPR 8715.6, additional information in NASA-STD 8719.14, App B [Baseline at SMSR]. <i>For guidance see Section 2.6, 3.5 and Appendix C.1.</i>	OSMA	Yes			A			
37	Table I-4		15. Mission Report. [Optional per NPR 7120.5, Table I-4 Project Milestone Products Maturity Matrix] <i>For guidance see Section 2.6 and Appendix C.1.</i>	OCE				A			
38	Table I-4		16. Decommissioning/Disposal Plan [Baseline at DR] [Required per NPR 7123.1]	OCE	Yes			A			
39	Table I-4		17. Industrial Base and Supply Chain Risk Management (SCRM) Strategy and Status [Baseline at PDR] [Required per NPR 8735.2]	OSMA	No			A			
40	Table I-4		18. Criticality Identification Method for Hardware [Baseline at PDR] [Required per NPR 8735.2]	OSMA	No			A			

Number	NPR 7120.5F Paragraph no.	GLPR 7120.5.10 Paragraph no.	GLPR 7120.5.10/NPR 7120.5F, Requirement Statement	Requirement Owner	Delegated	MDAA	CD	PM	Comply?	Justification	Approval
41	Table I-4		1. FA [Baseline for Phase A at MCR; Baseline for Phase B at SDR/MDR]. [Required per NPR 7120.5] For guidance see Section 2.6, 3.10, Appendix C.1 and Appendix E.	OCE	Yes	A	A	A			
42	Table I-4		2. PP [Baseline at PDR]. [Required per NPR 7120.5] For guidance see Section 2.6, 3.10, Appendix C.1 and Appendix F.	OCE	Yes	A	A	A			
43	Table I-4		3. Documentation of performance against Formulation Agreement (see #1 above) or against plans for work to be accomplished during Implementation life-cycle phase, including performance against baselines and status/closure of formal actions from previous KDP [Required per NPR 7120.5] For guidance see Section 2.6 and Appendix C.1.	OCE	Yes			A			
44	Table I-4		5. Project Baselines [Baseline at PDR]. For guidance see Sections 2.6, 3.11, and Appendix C.1.	NN/A	N/A						
45	Table I-4		5.a. Top technical, cost, schedule, and safety risks; risk mitigation plans; and associated resources. [Required per NPR 7120.5] For guidance see Section 2.6 and Appendix C.1.	OCE	Yes			A			
46	Table I-4		5.b. Staffing requirements and plans. For guidance see Sections 2.6, 3.7 and Appendix C.1. [Required per NPR 7120.5]	OCE	Yes			A			
47	Table I-4		5.c.i Infrastructure requirements and plans. [Required per NPR 9250.1, NPD 8800.14, and NPR 8820.2] For guidance see Section 2.6 and Appendix C.1. Business case analysis for infrastructure [Required per NPR 8800.15]	OSIOSI-FRED	No			A			
48	Table I-4		5.c.ii Capitalization Determination Form (CDF) (NASA Form 1739) [Required per NPR 9250.1]	OCFO	No			A			
49	Table I-4		5.d. Schedule [Baseline Integrated Master Schedule at PDR]. [Required per NPR 7120.5] For guidance see Section 2.6, 3.8, and Appendix C.1.	OCFO-SID	No			A			
50	Table I-4		5.e. Cost Estimate (Risk-Informed or Schedule-Adjusted Depending on Phase) [Baseline at PDR]. For guidance see Sections 2.6 and 3.7 and Appendix C.1.	OCFO-SID	No			A			
51	Table I-4		5.f. BOE (cost and schedule). [Required per NPR 7120.5] For guidance see Sections 2.6 and 3.7 and Appendix C.1.	OCFO-SID	No			A			
52	Table I-4		5.g. Baseline Joint Cost and Schedule Confidence Level(s) and supporting documentation. [Required per NPR 7120.5] For guidance see Sections 2.6 and 3.8 and Appendix C.1.	OCFO-SID	No			A			
53	Table I-4		5.h. External Cost and Schedule Commitments [Baseline at PDR]. [Required per NPR 7120.5] For guidance see Section 2.6 and Appendix C.1.	OCFO-SID	No	A		A			
54	Table I-4		5.i. CADRe [Baseline at PDR]. [Required per NPR 7120.5] For guidance see Section 2.6 and Appendix C.1.	OCFO-SID	No			A			
55	Table I-4		6. j. PMB [Baseline at PDR] [Required per NPR 7120.5]	OCFO-SID	No			A			
56	Table I-5		1. Technical, Schedule, and Cost Control Plan [Baseline at SDR/MDR]. [Required per NPR 7120.5] For guidance see Section 2.6 and Appendices C.1 and F.	OCE	Yes			A			
57	Table I-5		2. Safety and Mission Assurance Plan [Baseline at SRR] [Required per NPR]. For guidance see Section 2.6 and 8705.2 and 8705.4 Appendices C.1 and F.	OSMA	Yes			A			
58	Table I-5		3. Risk Management Plan [Baseline at SRR] [Required per NPR 8000.4]. For guidance see Section 2.6 and Appendices C.1 and F.	OSMA	Yes			A			

Number	NPR 7120.5F Paragraph no.	GLPR 7120.5.10 Paragraph no.	GLPR 7120.5.10/NPR 7120.5F, Requirement Statement	Requirement Owner	Delegated	MDAA	CD	PM	Comply?	Justification	Approval
59	Table I-5		4. Acquisition Plan [Baseline at SRR]. <a href="#">[Required per NPD1000.5]</a> For guidance see Section 2.6 and Appendices C.1 and F.	OCE	Yes			A			
60	Table I-5		5. Technology Development Plan (may be part of FA) [Baseline at MCR. <b>Per NPR 7120.5 Table I-5, this document is considered a Best Practice, not a requirement.</b> For guidance see Section 2.6 and Appendices C.1 and F.	OCT				A			
61	Table I-5		6. Systems Engineering Management Plan [Baseline at SRR]. [Required per NPR 7123.1] <a href="#">For guidance see Section 2.6 and Appendices C.1 and F.</a>	OCE	Yes			A			
62	Table I-5		7. System Security Plan [Baseline at CDR] [Required per NPR 2810.1]	OCIO	No			A			
63	Table I-5		8. Software Management Plan(s) [Baseline at SDR/MDR] [Required per NPR 7150.2, additional information information in NASA STD 8739.8]. <a href="#">For guidance see Section 2.6 and Appendices C.1 and F.</a>	OCE	No			A			
64	Table I-5		9. Verification and Validation Plan [Baseline at PDR]. [Required per NPR 7120.5, additional information in NPR 7123.1] <a href="#">For guidance see Section 2.6 and Appendices C.1 and F.</a>	OCE	Yes			A			
65	Table I-5		10. Review Plan [Baseline at SRR] ] [Required per NPR 7120.5] <a href="#">For guidance see Section 2.6 and Appendices C.1 and F.</a>	OCE	Yes			A			
66	Table I-5		11. Mission Operations Plan [Baseline at ORR]. [Required per NPR 7120.5] <a href="#">For guidance see Section 2.6 and Appendices C.1 and F.</a>	OCE	Yes			A			
67	Table I-5		12. NEPA Compliance Documentation [Baseline at SDR/MDR] [Required per NPR 8580.1] <a href="#">For guidance see Section 2.6 and Appendices C.1 and F.</a>	EMD	No			A			
68	Table I-5		13. Integrated Logistics Support Plan [Baseline at PDR] Required [per NPD 7500.1]. <a href="#">For guidance see Section 2.6 and Appendices C.1 and F.</a>	LPMO	No			A			
69	Table I-5		14. Science Data Management Plan [Baseline at ORR] [per NPD 2200.1 and NPRs 2200.2 and 1441.1]. <b>Per NPR 7120.5 Table I-5, this document is considered a Best Practice, not a requirement.</b> <a href="#">For guidance see Section 2.6 and Appendices C.1 and F.</a>	SMD	Yes			A			
70	Table I-5		15. Integration Plan [Baseline at PDR]. [Required per NPR 7120.5] <a href="#">For guidance see Section 2.6 and Appendices C.1 and F.</a>	OCE	Yes			A			
71	Table I-5		16. Configuration Management Plan [Baseline at SRR]. [Required per NPR 7120.5, additional information in NPR 7123.1 and SAE/EIA 649] <a href="#">For guidance see Section 2.6 and Appendices C.1 and F.</a>	OCE	Yes			A			
72	Table I-5		17. Security Plan [Baseline at PDR] [per NPD 1600.2 and NPRs 1600.1 and 1040.1]. <a href="#">For guidance see Section 2.6 and Appendices C.1 and F.</a>	OPS	No			A			
73	Table I-5		18. Project Protection Plan [Baseline at PDR]. [Required per NPR NPR1058.1, additional information in NASA-STD-1006] <a href="#">For guidance see Section 2.6 and Appendices C.1 and F.</a>	OCE	No			A			
74	Table I-5		19. Technology Transfer (formerly Export) Control Plan [Baseline at PDR] [per NPR 2190.1]. [Required per NPR 2190.1] <a href="#">For guidance see Section 2.6 and Appendices C.1 and F.</a>	OIIR	No			A			
75	Table I-5		20. Knowledge Management Plan [Baseline at PDR] [per NPD 7120.4 and NPDD 7120.6]. <b>Per NPR 7120.5 Table I-5, this document is considered a Best Practice, not a requirement.</b> <a href="#">For guidance see Section 2.6 and Appendices C.1 and F.</a>	OCE				A			

Number	NPR 7120.5F Paragraph no.	GLPR 7120.5.10 Paragraph no.	GLPR 7120.5.10/NPR 7120.5F, Requirement Statement	Requirement Owner	Delegated	MDAA	CD	PM	Comply?	Justification	Approval
76	Table I-5		21. Human Rating Certification Package [Baseline at SDR/MDR] [Required per NPR 8705.2]. <b>For guidance see Section 2.6 and Appendices C.1 and F.</b>	OSMA	No			A			
77	Table I-5		22. Planetary Protection Plan [Baseline at PDR]. <b>For guidance see Section 2.6 and Appendices C.1 and F.</b>	SMD	No			A			
78	Table I-5		23. Nuclear Safety Launch Approval Plan [Baseline at SDR/MDR] [per NPR 8715.3]. <b>For guidance see Section 2.6 and Appendices C.1 and F.</b>	OSMA	No			A			
79	Table I-5		24. Range Safety Risk Management Process Documentation [Baseline at SIR] [per NPR 8715.5]. <b>For guidance see Section 2.6 and Appendices C.1 and F.</b>	OSMA	Yes			A			
80	Table I-5		27. Communications Plan [Baseline at PDR]. <b>Per NPR 7120.5 Table I-5, this document is considered a Best Practice, not a requirement. For guidance see Section 2.6 and Appendices C.1 and F.</b>					A			
81	Table I-5		26. Quality Assurance Surveillance Plan [Baseline at SDR] [Required per NPR 8735.2 and NASA FAR Supplement part 1837.604]	OSMA	Yes			A			
82	Table I-5		27. Orbital Collision Avoidance Plan [Baseline at PDR] [Required per NID 7120.132]	OCE	No			A			
83	Table I-5		28. Human Systems Integration Plan [Baseline at SRR] [additional information in NASA/SP-20210010952 NASA HSI Handbook and NPR 7123.1]	OCE-OSMA-OCHMO <sup>1</sup>	No			A			
84	2.2.8		Projects with a life-cycle cost (LCC) or initial capability cost (see Section 2.4.1.3.b) estimated to be greater than \$250M <b>shall</b> perform earned value management (EVM) and comply with EIA-748, Standard for Earned Value Management Systems for all portions of work including in-house and contracted portions of the project. <b>For guidance see Section 3.19.</b>	OCFO-SID	No			A			
85	2.2.8.1		Project managers with projects subject to EVM <b>shall</b> utilize the NASA EVM Capability Process for in-house work. <b>For guidance see Section 3.19.</b>	OCFO-SID	No			A			
86	2.2.8.2		EVM system requirements for contracted work <b>shall</b> be applied to suppliers in accordance with the NASA Federal Acquisition Regulation (FAR) Supplement, independent of phase and the \$250M threshold ( <a href="https://www.hq.nasa.gov/office/procurement/regs/NFS.pdf">https://www.hq.nasa.gov/office/procurement/regs/NFS.pdf</a> <a href="https://www.hq.nasa.gov/office/procurement/regs/NFS.pdf">https://www.hq.nasa.gov/office/procurement/regs/NFS.pdf</a> ). <b>For guidance see Section 3.19.</b>	OCFO-SID	No			A			
87	2.2.8.3		Mission Directorates <b>shall</b> conduct an IBR in preparation for KDP C and for major changes that significantly impact the cost and schedule baseline.	OCFO-SID	No	A		A			
88	2.2.8.4		EVMS surveillance <b>shall</b> be conducted on contracts and programs and projects with in-house work to ensure continued compliance with EIA-748, Standard for Earned Value Management Systems.	OCFO-SID	No	A		A			
89	2.2.10		Each Project <b>shall</b> complete and attach a Compliance Matrix to the FA for Projects in Formulation or a PP when Projects reach Implementation per this section. <b>For guidance see Section 2.6 and Appendix C.1.</b>					A	Y		
90	2.2.11		Projects <b>shall</b> develop a Project Protection Plan that addresses NASA-STD-1006, Space System Protection Standard in accordance with NPR 1058.1, Enterprise Protection Program.	OCE	No			A			
91	2.3.1		Each Project <b>shall</b> have a DA who is the Agency's responsible individual who determines whether and how the program or Project proceeds through the life cycle and the key program or Project cost, schedule, and content parameters that govern the remaining life-cycle activities. <b>For guidance see Section 2.5.</b>	OCE	No			A			

Number	NPR 7120.5F Paragraph no.	GLPR 7120.5.10 Paragraph no.	GLPR 7120.5.10/NPR 7120.5F, Requirement Statement	Requirement Owner	Delegated	MDAA	CD	PM	Comply?	Justification	Approval
92	2.3.2		Each program and Project <b>shall</b> have a governing PMC. <b>For guidance see Section 2.2.</b>	OCE	No	A					
93	2.3.3		The Center Director (or designee) <b>shall</b> oversee programs and Projects usually through the CMC, which monitors and evaluates all program and Project work (regardless of category) executed at that Center. <b>For guidance see Sections 2.2 and 3.23.</b>	OCE	No		A				
94	2.3.4		Following each LCR, the independent SRB and the program or Project <b>shall</b> brief the applicable management councils on the results of the LCR to support the councils' assessments. <b>For guidance see Section 3.25.</b>	OCE	No		A	A			
95	2.3.5		Following each LCR, the independent SRB chair and the program or project manager <b>shall</b> brief the applicable management councils on the results of the LCR to support the councils' assessments.	OCE	No	A	A	A			
96	2.4.1		The decisions by the DA on whether and how the project proceeds into the next phase <b>shall</b> be summarized and recorded in the Decision Memorandum signed at the conclusion of the governing PMC by all parties with supporting responsibilities, accepting their respective roles. <b>For guidance see Section 3.25.</b>	OCE	No	A					
97	2.4.1.1		The Decision Memorandum <b>shall</b> describe the constraints and parameters within which the Agency, the Program Manager, and the PM will operate; the extent to which changes in plans may be made without additional approval; any additional actions that came out of the KDP; and the supporting data (i.e., the cost and schedule datasheet) that provide further details. <b>For guidance see Section 3.25.</b>	OCE	No	A		A			
98	2.4.1.2		A divergence from the Management Agreement that any party identifies as significant <b>shall</b> be accompanied by an amendment to the Decision Memorandum. <b>For guidance see Section 2.7.</b>	OCE	No	A		A			
99	2.4.1.3		During Formulation, the Decision Memorandum <b>shall</b> establish a target life-cycle cost range (and schedule range, if applicable) as well as the Management Agreement addressing the schedule and resources required to complete Formulation. <b>For guidance see Section 3.25.</b>	OCFO-SID	No	A		A			
100	2.4.1.3a		For projects with a LCC or initial capability cost greater than or equal to \$1B, the Decision Memorandum <b>shall</b> establish a high and low value for cost and schedule with the corresponding JCL value at KDP B.	OCFO-SID	No	A		A			
101	2.4.1.5		All Projects <b>shall</b> document the Agency's life-cycle cost estimate and other parameters in the Decision Memorandum for Implementation (KDP C), and this becomes the ABC. <b>For guidance see Section 3.25.</b>	OCFO-SID	No	A		A			
102	2.4.1.5a		For all single-project programs and projects with a definite Phase E end point, the Agency's LCC estimate and other parameters <b>shall</b> become the ABC.	OCFO-SID	No	A		A			
103	2.4.1.5b		For single-project programs and projects that plan continuing operations and production, including integration of capability upgrades, with an unspecified Phase E end point, the initial capability cost estimate and other parameters <b>shall</b> become the ABC.	OCFO-SID	No	A		A			
104	2.4.1.8		Projects <b>shall</b> be rebaselined when: (1) the estimated development cost exceeds the ABC development cost by 30 percent or more (for projects over \$250M, also that Congress has reauthorized the project); (2) the NASA AA judges that events external to the Agency make a rebaseline appropriate; or (3) the NASA AA judges that the program or project scope defined in the ABC has been changed or the project has been interrupted.	OCFO-SID	No	A		A			

Number	NPR 7120.5F Paragraph no.	GLPR 7120.5.10 Paragraph no.	GLPR 7120.5.10/NPR 7120.5F, Requirement Statement	Requirement Owner	Delegated	MDAA	CD	PM	Comply?	Justification	Approval
105	2.4.2		The program or project <b>shall</b> document the basis of estimate (BOE) for cost estimates and planned schedules in retrievable program or project records. <b>For guidance see Sections 3.7 and 3.8.</b>	OCFO-SID	No			A			
106	2.4.3.1 a		Single-project programs with an estimated LCC under \$1B and projects with an estimated LCC greater than \$250M and under \$1B <b>shall</b> provide a range of cost and a range for schedule, each range (with confidence levels identified for the low and high values of the range) established by a probabilistic analysis and based on identified resources and associated uncertainties by fiscal year. A joint cost and schedule confidence level (JCL) is not required but may be used. <b>For guidance see Section 3.8.</b>	OCFO-SID	No			A			
107	2.4.3.1b		Single-project programs and projects with an estimated LCC greater than or equal to \$1B <b>shall</b> develop a JCL and provide a high and low value for cost and schedule with the corresponding JCL value (e.g., 50 percent, 70 percent). <b>For guidance see Section 3.8.</b>	OCFO-SID	No			A			
108	2.4.3.2		At KDP C, single-project programs (regardless of LCC) and projects with an estimated LCC greater than \$250M <b>shall</b> develop a cost-loaded schedule and perform a risk-informed probabilistic analysis that produces a JCL. <b>For guidance see Section 3.8.</b>	OCFO-SID	No			A			
109	2.4.3.3		At CDR, single-project programs and projects with an estimated LCC greater than or equal to \$1B <b>shall</b> update their KDP C JCL and communicate the updated JCL values for the ABC and Management Agreement to the APMC for informational purposes.	OCFO-SID	No			A			
110	2.4.3.4		At KDP D, single-project programs and projects with an estimated LCC greater than or equal to \$1B <b>shall</b> update their JCL if current reported development costs have exceeded the development ABC cost by 5 percent or more and document the updated JCL values for the ABC and Management Agreement in the KDP D Decision Memorandum.	OCFO-SID	No			A			
111	2.4.3.5		When a single-project program (regardless of LCC) or project with an estimated LCC greater than \$250M is rebaselined, a JCL <b>shall</b> be calculated and evaluated as a part of the rebaselining approval process.	OCFO-SID	No	A		A			
112	2.4.4.1		Any JCL approved by the DA at less than 70 percent <b>shall</b> be justified and documented. <b>For guidance see Section 3.8.</b>					A			
113	2.4.4.2		When a single-project program (regardless of LCC) or project with an estimated LCC greater than \$250M is rebaselined, a JCL <b>shall</b> be calculated and evaluated as a part of the rebaselining approval process.	OCFO-SID	No	A					
114	2.4.4.3		When a single-project program (regardless of LCC) or project with an estimated LCC greater than \$250M is rebaselined, a JCL <b>shall</b> be calculated and evaluated as a part of the rebaselining approval process.	OCFO-SID	No	A					
115	2.4.4.4		When a single-project program (regardless of LCC) or project with an estimated LCC greater than \$250M is rebaselined, a JCL <b>shall</b> be calculated and evaluated as a part of the rebaselining approval process.	OCFO-SID	No	A					
116	2.4.4.5		When a single-project program (regardless of LCC) or project with an estimated LCC greater than \$250M is rebaselined, a JCL <b>shall</b> be calculated and evaluated as a part of the rebaselining approval process.	OCFO-SID	No	A					
117	2.4.5		Tightly coupled, loosely coupled, and uncoupled-programs <b>shall</b> provide analysis of the program's risk posture to the governing PMC as each new project reaches KDP B and C or when a project's ABC is rebaselined.	OCFO-SID	No	A		A			

Number	NPR 7120.5F Paragraph no.	GLPR 7120.5.10 Paragraph no.	GLPR 7120.5.10/NPR 7120.5F, Requirement Statement	Requirement Owner	Delegated	MDAA	CD	PM	Comply?	Justification	Approval
118	3.3.1		Projects <b>shall</b> follow the TA process established in Section 3.3 of NPR 7120.5F. <b>For guidance see Section 2.7, 3.26, and the "NASA Space Flight Program and Project Handbook," Section 5.2.</b>	OCE	No	A	A	A			
119	3.4.1		Projects <b>shall</b> follow the Formal Dissent process. <b>For guidance see Sections 2.7 and 3.26.</b>	OCE	No	A	A	A			
120	3.5.1		Projects <b>shall</b> follow the tailoring process in NPR 7120.5F, Section 3.5. <b>For guidance see Section 2.6 and the "NASA Space Flight Program and Project Handbook," Section 5.4.</b>	OCE	No	A	A	A			
121	3.5.5	NA	A request for a permanent change to a prescribed requirement in an Agency or Center document that is applicable to all programs and Projects <b>shall</b> be submitted as a "Change Request" to the office responsible for the requirements policy document unless formally delegated elsewhere. <b>For guidance see the "NASA Space Flight Program and Project Handbook," Section 5.4.</b>	OCE	No	A	A	A			
122	3.6.1	NA	A Center negotiating reimbursable space flight work with another agency <b>shall</b> propose NPR 7120.5F as the basis by which it will perform the space flight work. <b>For guidance see Section 2.2.</b>	OCE	No		A				
123	3.7.1	NA	Each program and Project <b>shall</b> perform and document an assessment to determine an approach that maximizes the use of SI. <b>For guidance see the "NASA Space Flight Program and Project Handbook," Section 4.3.4.3.</b>	OCE	No			A			

## APPENDIX D. Project/Task Scope Summary Template Example

Acronyms in this appendix are defined in Appendix B.

GRC Space Flight Systems Project/Task Scope Summary												
1	Project/Task Title:		2	6-digit WBS:		3	Project Document No.:		4	Date:		
5	Customer/Mission Directorate:		6	Theme:		7	Program (Level II):		8	Project (Level III):		
9	Responsible GRC Org:		10	Project Manager:								
11	Chief Engineer:		12	Chief Safety & Mission Assurance Officer:								
13	Stakeholder Expectations: Mission Statement Top Level Needs, Goals, Objectives, Constraints:											
14	Governing NPR:	7120.5	15	GRC Project/Task Classification (per GLPR Table 2-1):	Gold	16	Payload Risk Classification: (NPR 8705.4)		17	Software Classification:		
18	Ref. Mission/System Architecture:											
19	Key Project Deliverables:											
20	Acquisition (Make/Buy) Strategy: (i.e. in house, prime contract, partnership, etc)											
21	Top Level Risks: (Qualitative):											
22	Key Partners:											
23	Other External Stakeholders:											
<b>Budget Marks:</b>												
Fiscal Year												Life Cycle Total
FTE Count												0.0
WYE												0.0
Proc/Travel (\$K) (Incl WYE Cost)												\$0.00

Milestone Schedule:												
PTR# (NPR 7120.8)												
Target Date												

**Continuation Block**

Type Block Number of Items to be continued in space below, as necessary.

**Signature Block**

Requestor/Project Manager: \_\_\_\_\_ Date: \_\_\_\_\_

Approve     
  Disapprove     
  Approve with Comments

PRB Chair: \_\_\_\_\_ Date: \_\_\_\_\_

**PRB Comments:**

## APPENDIX E. Project Formulation Agreement (FA) Template and Instructions

A Microsoft (MS) Word Project FA Template can be found in the GRC Business Management System (BMS) [Library > Center Templates > Engineering/Program and Project Templates](#).

### E.1 FA Template Instructions

- a. The FA represents the Project's or single-Project program's response to the Formulation Authorization Document (FAD). It establishes technical and acquisition work that needs to be conducted during Formulation and defines the schedule and funding requirements during Phase A and Phase B for that work. The Agreement focuses on the Project or single-Project program activities necessary to accurately characterize the complexity and scope of the Project or single-Project program; increase understanding of requirements; and identify and mitigate high technical, acquisition, safety, cost, and schedule risks. It identifies and prioritizes the Phase A and Phase B technical and acquisition work that will have the most value and enables the Project or single-Project program to develop high-fidelity cost and schedule range estimates at Key Decision Point (KDP) B and high-fidelity cost and schedule commitments at KDP C.
- b. The FA serves as a tool for communicating and negotiating the Project's or single-Project program's Formulation plans and resource allocations with the program and Mission Directorate. It allows for differences in approach between competed versus assigned missions. Variances with NPR 7120.5 product maturities as documented in Appendix I of NPR 7120.5 are identified with supporting rationale in the FA. The approved FA serves as authorization for these variances. The FA is approved and signed at KDP A and is updated and resubmitted for signature at KDP B. The FA for KDP A includes detailed Phase A information and preliminary Phase B information. The FA for KDP B identifies the progress made during Phase A and updates and details Phase B.
- c. Each section of the FA template is required. If a section is not applicable to a particular Project or single-Project program, the Project or single-Project program indicates that in the appropriate section and provides a rationale. If a section is applicable but the Project or single-Project program desires to omit the section or parts of a section, then a waiver or deviation needs to be obtained in accordance with the tailoring process, Section 2.6. Approvals for waivers are documented in the Compliance Matrix (Appendix C), and the Compliance Matrix for this GLPR is attached to the FA. If the format of the completed Project or single-Project FA differs from this template, a cross-reference table indicating the location of the information for each template paragraph needs to be provided with the document when it is submitted for the Mission Directorate Associate Administrator (MDAA) signature.
- d. The approval signatures of the MDAA, Center Director, and program manager certify that the FA implements all the Agency's applicable institutional requirements or that the owner of those requirements (e.g., Safety and Mission Assurance) has agreed to the modification of those requirements in the FA.
- e. Products developed as part of, or as a result of, the FA may be incorporated into the Project or Single-Project Program Plan, if appropriate, as the Project or Single-Project Program Plan

is developed during Formulation. The Project or single-Project program may use the preliminary Project or Single-Project Program Plan to describe and control the Project's or single-Project program's execution as long as the Project or Single-Project Program Plan does not conflict with the FA.

## E.2 FA Template

*The following are basic elements the cover should contain.*

<b>[<i>Project or Single-Project Program Name</i>] Formulation Agreement</b>	
<b>[<i>short title or acronym</i>]</b>	
(Provide a title for the candidate project or single-project program and designate a short title or proposed acronym in parenthesis, if appropriate.)	
_____	_____
Mission Directorate Associate Administrator	Date
_____	_____
Center Director (as many signature lines as needed)	Date
_____	_____
Program Manager	Date
_____	_____
Project Manager	Date
By signing this document, signatories are certifying that the content herein is acceptable as direction for managing this project or single-project program and that they will ensure its implementation by those over whom they have authority.	

**Figure F-1. FA Title Page**

## CONTENTS

1.0 PURPOSE .....	5
2.0 PROJECT OR SINGLE-PROJECT PROGRAM FORMULATION FRAMEWORK .....	5
3.0 PROJECT OR SINGLE-PROJECT PROGRAM PLAN AND PROJECT OR SINGLE-PROJECT PROGRAM CONTROL PLANS .....	5
4.0 PROJECT OR SINGLE-PROJECT PROGRAM, SYSTEM, AND SUBSYSTEM REQUIREMENTS FLOW DOWN .....	5
5.0 MISSION SCENARIO, ARCHITECTURES, AND INTERFACES .....	5
6.0 TRADE STUDIES .....	6
7.0 RISK MITIGATION .....	6
8.0 TECHNOLOGY READINESS ASSESSMENT AND DEVELOPMENT .....	6
9.0 ENGINEERING DEVELOPMENT ASSESSMENT, PROTOTYPING, AND SOFTWARE MODELS .....	7
10.0 HERITAGE ASSESSMENT AND VALIDATION .....	7
11.0 ACQUISITION STRATEGY AND LONG-LEAD PROCUREMENTS .....	8
12.0 FORMULATION PHASE REVIEWS .....	8
13.0 FORMULATION PHASE COST AND SCHEDULE ESTIMATES .....	8
14.0 LEADING INDICATORS .....	9
APPENDIX A. ACRONYMS .....	10
APPENDIX B. DEFINITIONS .....	11
APPENDIX C. COMPLIANCE MATRIX .....	12

## CHANGE HISTORY

Rev./Change	Date	Description/Comments

# **[PROJECT OR SINGLE-PROJECT PROGRAM NAME]**

## **FORMULATION AGREEMENT**

*[short title or acronym]*

### **1.0 PURPOSE**

Describe the purpose of the Program/Project, including traceability from the Formulation Authorization Agreement (FAD).

### **2.0 PROJECT OR SINGLE-PROJECT PROGRAM FORMULATION FRAMEWORK**

Identify the Project or single-Project program organization chart for Formulation; identify the initial Project or single-Project program team, key personnel, and responsible centers and partnerships (as known) that will contribute during Formulation. Define major roles and responsibilities and identify any boards and panels that will be used during Formulation for decision making and managing Project or single-Project program processes.

Specifically identify the Decision Authority (DA) and governing Program Management Council (PMC) for oversight of the program or project, and any delegated DA and delegated governing PMC, per Section 2.3 of NPR 7120.5.

### **3.0 PROJECT OR SINGLE-PROJECT PROGRAM PLAN AND PROJECT OR SINGLE-PROJECT PROGRAM CONTROL PLANS**

Document the Project's or single-Project program's proposed milestones for delivery of the Project or Single-Project Program Plan and Project or single-Project program control plans on the Project or single-Project program schedule and provide rationale for any differences from requirements in product maturities as documented in Appendix H of GLPR 7120.5.10.

### **4.0 PROJECT OR SINGLE-PROJECT PROGRAM, SYSTEM, AND SUBSYSTEM REQUIREMENTS FLOW DOWN**

Document the Project's or single-Project program's proposed milestones for flow down of requirements to the Project or single-Project program, system, and subsystem levels on the Project or single-Project program schedule and provide rationale for any differences from requirements in product maturities as documented in Appendix H of GLPR 7120.5.10.

Document the Project or single-Project program schedule for development of any models needed to support requirements development.

### **5.0 MISSION SCENARIO, ARCHITECTURES, AND INTERFACES**

Document the Project's or single-Project program's proposed milestones for producing the mission concept, mission scenario (or design reference mission), concept of operations, and mission, spacecraft, payload, and ground systems architectures down to the level of subsystem interfaces. Include these milestones on the Project or single-Project program schedule and provide rationale for any differences from requirements documented in the tables in Appendix H of GLPR 7120.5.10.

Reference documentation of the feasible concept, concepts already evaluated, and plans for additional concepts to be evaluated during Formulation. Documentation should include ground rules, assumptions, and constraints used for analysis; key architecture drivers, such as redundancy; preliminary key performance parameters; top-level technical parameters and associated margins; and preliminary driving requirements. Documentation should also include feasible candidate architectures, open architecture issues and how and when those issues will be resolved, basic descriptions of each element, and descriptions of interfaces between elements.

At KDP B, update the approved concept and architecture, including a preliminary definition of the operations concept and updated description of the composition of the payload/suite of instruments. Identify the work required to close all architecture and architectural interface issues.

## **6.0 TRADE STUDIES**

Identify spacecraft and ground systems design trade studies planned during Phases A and B, including trade studies that address performance versus cost and risk.

## **7.0 RISK MITIGATION**

Document plans for managing risks during Formulation. Identify the Project's or single-Project program's major technical, acquisition, safety, cost, and schedule risks to be addressed during Formulation, including risks likely to drive the Project's or single-Project program's cost and schedule range estimates at KDP B and at KDP C. Describe the associated risk mitigation plans. Provide rationale for addressing these risks during Formulation.

Document the Project's or single-Project program's risk mitigation schedule and funding requirements. Include intermediate milestones and expected progress by KDP B and KDP C.

## **8.0 TECHNOLOGY READINESS ASSESSMENT AND DEVELOPMENT**

Identify the specific new technologies (Technology Readiness Level (TRL) less than 6) that are part of this Project or single-Project program; their criticality to the Project's or single-Project program's objectives, goals, and success criteria; and the current status of each planned technology development, including TRL and associated risks. Describe the specific activities and risk mitigation plans, the responsible organizations, models, and key tests to ensure that the technology maturity reaches TRL 6 by the Preliminary Design Review (PDR). (Refer to NASA Procedural Requirements (NPR) 7123.1 for TRL definitions and SP-20205003605, Technology Readiness Assessment Best Practices Guide for technology readiness assessment best practices.)

Identify off-ramp decision gates and strategies for ensuring that there are alternative development paths available if technologies do not mature as expected. Identify potential cost, schedule, or performance impacts if the technology developments do not reach the required maturity levels.

Provide technology development schedules, including intermediate milestones and funding requirements, during Phases A and B for each identified technology development to achieve TRL 6 by PDR. Describe the expected status of each technology development at the System Requirements Review (SRR), Mission Definition Review/System Definition Review (MDR/SDR), and PDR. Reference the preliminary or final Technology Development Plan for details as applicable. Describe how the program will transition technologies from the development stage to manufacturing, production, and insertion into the end system. Identify any

potential costs and risks associated with the transition to manufacturing, production, and insertion. Develop and document appropriate mitigation plans for the identified risks.

## **9.0 ENGINEERING DEVELOPMENT ASSESSMENT, PROTOTYPING, AND SOFTWARE MODELS**

Identify major engineering development risks and any engineering prototyping or software model development that needs to be accomplished during Phases A and B to reduce development risk. (Engineering development risks include components and assemblies that have not been previously built or flown in the planned environment or that have been significantly modified in functionality, interfaces, power consumption, size, or use of materials.) Provide rationale and potential impacts to Project or single-Project program performance, cost, and schedule if development risks are not addressed. Describe the scope of the prototyping and modeling activities and the expected reduction of cost and risk by performing this work during Formulation. Include the Project or single-Project program's testing philosophy, including functional, environmental, and qualification testing; any life testing and protoflight test plans; and rationale.

Describe the prototypes and software models to be built, their fidelity (form, fit, and function, etc.), the test environments and objectives, and test dates. Identify any design alternatives if irresolvable problems are encountered.

Provide prototype and software model development and test schedules, including intermediate milestones and funding requirements during Phases A and B. Describe expected status and accomplishments for each prototype or software model at SRR, MDR/SDR, and PDR. Focus during Phase A should be on component and subassembly prototypes built to approximately the correct size, mass, and power, with "flight-like" parts and materials, and tested in a laboratory environment over the extremes of temperature and radiation (if relevant). Focus during Phase B should be on testing form, fit, and function prototypes over the extremes of what will be experienced during flight.

Identify key performance parameters, associated modeling methodologies, and methods for tracking KPPs throughout Formulation. In addition, identify any planned investments, divestments, acquisition strategies, procurements, agreements, and changes to capability portfolio capability components in accordance with requirements and strategic guidance included in NPR 8600.1, NASA Capability Portfolio Management Requirements. (See Appendix A for definitions of capability portfolio and capability component.)

## **10.0 HERITAGE ASSESSMENT AND VALIDATION**

Identify the major heritage hardware and software assumptions and associated risks, as well as the activities and reviews planned to validate those assumptions during Formulation. Identify schedule and funding requirements for those activities. See SP-20205003605, Technology Readiness Assessment Best Practices Guide.

## **11.0 ACQUISITION STRATEGY AND LONG-LEAD PROCUREMENTS**

Identify acquisition and partnership plans during Formulation. Document the Project's or single-Project program's proposed milestones for in-house work and procurements, including completing any contract Statements of Work (SOW) and Requests for Proposal (RFP) during the Formulation phase. Identify long-lead procurements to be initiated and provide associated

rationale. Identify procurements of material and services necessary for life-cycle sustainment. Identify anticipated partnerships (other Government agencies and U.S. and international partners), if any, including roles and contributed items and plans for getting commitments for contributions and finalizing open interagency agreements, domestic partnerships, and foreign contributions. Point to the preliminary or final Acquisition Plan for details, as applicable.

Identify major acquisition risks, including long-lead procurement risks and partnership risks.

Identify funding requirements for procurement activities, long-lead procurements, and partnerships.

## **12.0 FORMULATION PHASE REVIEWS**

Identify and provide schedules for the Project or single-Project program life-cycle reviews (LCRs) (SRR, SDR/MDR) and the system and subsystem-level reviews to be held during Formulation. Include inheritance reviews, prototype design reviews, technology readiness reviews, fault protection reviews, and other reviews necessary to reduce risk and enable more accurate cost and schedule range estimates at KDP B and more accurate cost and schedule estimates at KDP C.

## **13.0 FORMULATION PHASE COST AND SCHEDULE ESTIMATES**

Document the Project's or single-Project program's Formulation phase schedule and phased funding requirements, including cost and schedule margins, aligned with the Project or single-Project program Work Breakdown Structure (WBS). Identify the critical path.

Ensure that all funding requirements in this FA are included and clearly identifiable. Summarize funding requirements both in dollars and estimated percent of total costs for Phases A–D.

Ensure that the schedules for all technology development, engineering prototyping, procurement and risk mitigation activities, and milestones identified in this FA are included and clearly identifiable. Provide schedule details to the appropriate level to justify Formulation funding requirements (typically subsystem level).

Include any additional milestones required in product maturities as documented in Appendix H of GLPR 7120.5.10, including the development of life-cycle cost and schedule ranges due at KDP B and the joint cost and schedule confidence level (JCL) at KDP C, if required.

If Earned Value Management (EVM) is required, identify the schedule for developing the Project's or single-Project program's EVM capabilities.

## **14.0 LEADING INDICATORS**

Project or single-Project programs develop and maintain the status of a set of programmatic and technical leading indicators to ensure that proper progress and management of the Project or single-Project program is achieved during Formulation. These include:

- Requirement trends (percent growth, to be determined/to be resolved (TBD/TBR) closures, and number of requirement changes).
- Interface trends (percent Interface Control Document (ICD) approvals, TBD/TBR burn down, and number of interface requirement changes).
- Review trends (Review Item Discrepancy (RID), Request for Action (RFA), and Action Item burn down per review).

- Formulation cost trends (plans, actual, Unallocated Future Expenses (UFE), and New Obligation Authority (NOA)).
- Schedule trends (slack/float and critical milestone dates).
- Staffing trends (Full-Time Equivalent (FTE) and Work Year Equivalent (WYE)).
- Technical Performance Measures (mass margin and power margin).
- Additional Project or single-Project program-specific indicators, as needed.

These indicators are further explained in the “NASA Space Flight Program and Project Management Handbook.”

## **APPENDIX A. ACRONYMS**

## **APPENDIX B. DEFINITIONS**

## **APPENDIX C. COMPLIANCE MATRIX**

## APPENDIX F. Project Plan Template and Instructions

A Microsoft (MS) Word Project Plan Template can be found in the GRC Business Management System (BMS) [Library > Center Templates > Engineering/Project and Program Templates](#).

### F.1 Template Instructions

- a. The PP is an agreement among the project manager, program manager, Center Director, and the Mission Directorate Associate Administrator (MDAA). Other Center Directors providing a significant contribution to the project also concur with the PP to document their commitment to provide required Center resources. It defines, at a high level, the scope of the project, the implementation approach, the environment within which the project operates, and the baseline commitments of the program and project. The PP is consistent with the Program Plan. The PP is updated and approved during the project life cycle in response to changes in program requirements on the project or the baseline commitments.
- b. In this PP template, all subordinate plans, collectively called control plans, are required unless they are not applicable or are marked as “Best Practice” in the applicable table in Appendix I (i.e., I-Table). (The expectation is that products marked as “Best Practice” will be developed per the I-Table as part of normal project management activities.) They are based on requirements in NASA Policy Directives (NPDs) and NASA Procedural Requirements (NPRs) that affect program/project planning. If a control plan is not applicable to a particular project, indicate that by stating it is not applicable in the appropriate section and provide a rationale. Control plans can either be a part of the PP or separate stand-alone documents referenced in the appropriate part of the PP. Considerations for determining if a control plan should be a stand-alone document include a requirement that the control plan be stand-alone in the NPR that requires the control plan; differences between when the control plan is baselined and when the PP is baselined; how frequently the control plan will be updated since updates to the PP require signatures; and how long the control plan is. When the control plan is a stand-alone document, the PP contains a reference to the stand-alone document.
- c. Each section of the PP template is required. If a section is not applicable to a particular Project, indicate by stating that in the appropriate section and provide a rationale. If a section is applicable but the Project desires to omit the section or parts of a section, then a waiver or deviation needs to be obtained in accordance with the requirement tailoring process for NPR 7120.5. If the format of the completed PP differs from this template, a cross-reference table indicating where the information for each template paragraph is needed to be provided with the document when it is submitted for signature. Approvals are documented in Part 4.0, Waivers or Deviations Log, of the PP. In addition, the Project’s Compliance Matrix for this NPR is attached to the PP.
- d. The approval signatures certify that the PP implements all of the NASA Glenn Research Center’s (GRC’s) applicable institutional requirements or that the authority responsible for those requirements (e.g., SMA) has agreed to the modification of those requirements in the PP.
- e. The red text indicates the recommendations for where to find information to incorporate into the PP, the blue text is recommended standard wording that can be used in a PP, and the black text describes what is needed in each section of a PP.

## F.2 Project Plan Template

*The following are basic elements the cover should contain.*

<b>[<i>Project Name</i>] Project Plan</b>	
<b>[<i>short title or acronym</i>]</b>	
(Provide a title for the candidate project and designate a short title or proposed acronym in parenthesis, if appropriate.)	
_____ Mission Directorate Associate Administrator	_____ Date
_____ Center Director (as many signature lines as needed)	_____ Date
_____ Program Manager	_____ Date
_____ Project Manager	_____ Date
By signing this document, signatories are certifying that the content herein is acceptable as direction for managing this project and that they will ensure its implementation by those over whom they have authority.	

# CONTENTS

1.0	PROJECT OVERVIEW .....	6
1.1	Introduction.....	6
1.2	Objectives .....	6
1.3	Mission Description and Technical Approach.....	6
1.4	Project Authority, Governance Structure, Management Structure, and Implementation Approach .....	7
1.5	Stakeholder Definition.....	8
2.0	PROJECT BASELINES .....	8
2.1	Requirements Baseline.....	8
2.2	WBS Baseline .....	8
2.3	Schedule Baseline .....	8
2.4	Resource.....	8
2.5	Joint Cost and Schedule Confidence Level .....	9
3.0	PROJECT CONTROL PLANS .....	9
3.1	Technical, Schedule, and Cost Control Plan.....	9
3.2	Safety and Mission Assurance Plan.....	11
3.3	Risk Management Plan .....	12
3.4	Acquisition Strategy.....	12
3.5	Technology Development Plan.....	13
3.6	Systems Engineering Management Plan.....	14
3.7	System Security Plan.....	14
3.8	Software Management Plan .....	15
3.9	Verification and Validation Plan .....	15
3.10	Review Plan .....	15
3.11	Mission Operations Plan.....	16
3.12	NEPAN EPA Compliance Documentation.....	17
3.13	Integrated Logistics Support Plan.....	17
3.14	Science Data Management Plan.....	17
3.15	Integration Plan.....	18
3.16	Configuration Management .....	18
3.17	Security Plan .....	18
3.18	Project Protection Plan.....	20
3.19	Technology Transfer Control Plan.....	21
3.20	Knowledge Management Plan .....	21
3.21	Human Rating Certification Package.....	21
3.22	Planetary Protection Plan.....	22
3.23	Nuclear Launch Authorization Plan.....	22
3.24	Range Flight Safety Risk Management Process Documentation .....	22
3.25	Payload Safety Process Deliverables .....	22
3.26	Communications Plan .....	23
3.27	Quality Assurance Surveillance Plan.....	23
3.28	Orbital Collision Avoidance Plan .....	23

3.29 Human systems Integration Plan ..... 23

4.0 WAIVERS OR DEVIATIONS LOG

5.0 CHANGE LOG

6.0 APPENDICES

APPENDIX A.—ACRONYMS .....24

### CHANGE HISTORY

Rev./Change	Date	Description/Comments

# [PROJECT NAME] PROJECT PLAN

[short title or acronym]

*The red text indicates the recommendations for where to find information to incorporate into the Project Plan (PP), the blue text is recommended standard wording that can be used in a PP, and the black text describes what is needed in each section of a PP.*

## 1.0 PROJECT OVERVIEW

### 1.1 Introduction

#### **From proposal text or FA**

Briefly describe the background of the Project and its current status, including results of Formulation activities, decisions, and documentation. Document the Project's category and NASA payload development risk classification (see NPR 8705.4) as stated in the program requirements on the Project.

### 1.2 Objectives

#### **From proposal text or FA**

State the specific Project objectives and high-level performance goals levied on the Project by the program. Include performance, schedule, cost, and technology development objectives, as applicable. Identify program requirements and constraints on the Project. Provide clear traceability to applicable Agency strategic goals.

### 1.3 Mission Description and Technical Approach

#### **From proposal text or FA**

Briefly describe the mission and the mission design. Include mission objectives and goals, mission success criteria, and driving ground rules and assumptions affecting the mission and mission design. Identify key characteristics of the mission, such as the launch date(s), flight plans, and key phases and events on the mission timeline, including end of mission. Use drawings, figures, charts, and other visual aids for clarification. Describe planned mission results, data archiving, and reporting.

Provide a brief description of the technical approach, including constituent launch, flight, and ground systems, operations concepts, and logistics concepts. Describe the systems to be developed (hardware and software), legacy systems, system interfaces, and facilities. Identify driving technical ground rules and assumptions, as well as major constraints affecting system development (e.g., cost, launch window, required launch vehicle, mission planetary environment, fuel/engine design, and international partners).

### 1.4 Project Authority, Governance Structure, Management Structure, and Implementation Approach

#### **From proposal text or FA. See "NASA Space Flight Program and Project Management Handbook"**

Identify the Center where the PM resides. Describe the governance structure based on the Project category and NASA Glenn Research Center (GRC) Project classification scheme. Identify the governing Program Management Council (PMC) responsible for oversight of the Project.

Describe the responsibilities, if any, of other centers. Describe the chain of accountability and decision path that outlines the roles and responsibilities of the PM, Program Manager, Center Director, Principal Investigator (PI), and project scientist, as appropriate, and other authorities as required per the Project's categorization. Describe the DA delegation path. This delegation may be from the MDAA to the center director to the SFS director for projects. For tasks, the DA delegation may be given to the appropriate division or branch chief or project manager.

Define the relationships among various elements and organizations within the Project structure, including all stakeholders, team members, and supporting organizations. (This includes the Technical Authority (TA).) Describe the Project's approach for fostering effective upward and downward communication of critical management, technical, risk, and safety information. (This includes the Formal Dissent process.) Describe the process that the Project will follow to communicate with the Center Management Council (CMC) and the Integrated Center Management Council (ICMC), if applicable. Briefly describe the process for problem reporting and subsequent decision making, clearly describing the roles and responsibilities of all organizations. Describe any use of special boards and committees. Define the percentage or amount of budget and/or schedule that a deviation or waiver is required to report to upper management.

Describe the Project management structure consistent with the Project Work Breakdown Structure (WBS), including the organization and responsibilities, the integration of the WBS with the parent program management structure, and NASA Center(s) participation. Describe clear lines of authority within the Project team and between the Project, the Program Office, the primary Center, the Mission Directorate, other participating centers, and other participating organizations. Illustrate the organization graphically.

Briefly describe the implementation approach of the Project, including any applicable guidance or direction from the Acquisition Strategy Meeting (ASM) review, the acquisition strategy (e.g., in-house, NASA centers, and contractor primes), partners, and partner contributions, if appropriate. Describe briefly other Project dependencies with NASA, other U.S. Government agencies, and international activities, studies, and agreements. Include make-or-buy decision plans and trade studies.

Describe how lessons learned and the implementation policies and practices of participating NASA centers will be utilized in the execution of the Project. Document the agreements on the use of implementation policies and practices between the PM and contributing NASA centers in this section (or in appendices to the document), along with the Project's approach to ensuring that interfaces do not increase risk to mission success.

## **1.5 Stakeholder Definition**

### **From proposal text or FA**

Describe the stakeholders of the Project (e.g., the PI, science community, technology community, public, education community, parent program, and Mission Directorate sponsor). Also describe the process to be used within the Project to ensure stakeholder advocacy.

## **2.0 PROJECT BASELINES**

Project baselines consist of a set of requirements, cost (including Project-held Unallocated Future Expenses (UFE)), schedule, and technical content that forms the foundation for Project

execution and reporting done as part of NASA’s performance assessment and governance process. (For more detail, see NASA Procedural Requirements (NPR) 7120.5, Section 2.4, on baseline policy and documentation.)

## **2.1 Requirements Baseline**

List or reference the requirements levied on the Project by the program in the Program Plan and discuss how these are flowed down to lower levels by summarizing the requirements allocation process. Reference requirements documents used by the Project.

## **2.2 WBS Baseline**

### **See “NASA Space Flight Program and Project Management Handbook” and MS Project Template**

Provide the Project’s WBS and WBS dictionary to the Level 2 elements in accordance with the standard template in Table 3-3 of GLPR 7120.5.10. The WBS will support cost and schedule allocation down to a work package level, integrate both government and contracted work, integrate well with the Earned Value Management System (EVMS) approach, allow for unambiguous cost reporting, and be designed to allow PMs to monitor and control work package/product deliverable costs and schedule.

## **2.3 Schedule Baseline**

### **Generate using MS Project Template Cost Model; Translator can be used for initial draft**

Present a summary of the Project’s Integrated Master Schedule (IMS), including all critical milestones, major events, life-cycle reviews (LCRs), and Key Decision Points (KDPs) throughout the Project life cycle. The summary of the master schedule should include the logical relationships (interdependencies) for the various Project elements and critical paths, as appropriate. Identify driving ground rules, assumptions, and constraints affecting the schedule baseline.

## **2.4 Resource**

### **Generate from MS Project IMS or Cost Model**

Present the Project funding requirements by fiscal year. State the New Obligation Authority (NOA) in real-year dollars for all years—prior, current, and remaining. The funding requirements are to be consistent with the Project WBS and include funding for all cost elements required by the Agency’s full-cost accounting procedures. Provide a breakdown of the Project’s funding requirements to the WBS Level 2 elements. Throughout the Implementation phase, cost and schedule baselines are to be based on and maintained consistent with the approved joint cost and schedule confidence level (JCL) in accordance with NASA Policy Directive (NPD) 1000.5.

Present the Project’s workforce requirements by fiscal year, consistent with the Project funding requirements and WBS. The workforce estimate is to encompass all work required to achieve Project objectives. Include the actual full-cost civil servant and support service contractor (SSC) workforce by the organizations providing them for any prior fiscal years. Include full-cost CS and SSC workforce requirements by the organizations providing them for the current fiscal year and remaining fiscal years.

Describe the Project’s infrastructure requirements (acquisition, renovations, and/or use of real property/facilities, aircraft, personal property, and information technology (IT)). Identify the

means of meeting infrastructure requirements through synergy with other existing and planned programs and Projects to avoid duplication of facilities and capabilities. Identify necessary upgrades or new developments, including those needed for environmental compliance.

Identify driving ground rules, assumptions, and constraints affecting the resource baseline.

## **2.5 Joint Cost and Schedule Confidence Level**

**Recommend following this requirement, when applicable, unless justification for waiving can be provided** Implementation and beyond of Projects with an estimated life-cycle cost (LCC) greater than \$250 million, document the Project's JCL approved by the DA and the basis for its consistency with the program's JCL.

## **3.0 PROJECT CONTROL PLANS**

### **3.1 Technical, Schedule, and Cost Control Plan**

#### **Can tailor to include in PP using Tailoring Tools**

Document how the Project plans to control Project requirements, technical design, schedule, and cost to achieve the program requirements on the Project. (If this information is best documented in other control plans, e.g., the Systems Engineering Management Plan (SEMP), then reference those control plans.) This control plan documents the following:

Describe the plan to monitor and control the Project requirements, technical design, schedule, and cost of the Project to ensure that the high-level requirements levied on the Project are met.

Describe the Project's performance measures in objective, quantifiable, and measurable terms, and document how the measures are traced from the program requirements on the Project. In addition, document the minimum mission success criteria associated with the program requirements on the Project that, if not met, trigger consideration of a Termination Review.

The Project also develops and maintains the status of a set of programmatic and technical leading indicators to ensure proper progress and management of the Project. These include:

- Requirement trends (percent growth, to be determined/to be resolved (TBD/TBR) closures, and number of requirement changes).
- Interface trends (percent Interface Control Document (ICD) approval, TBD/TBR burn down, and number of interface requirement changes).
- Verification trends (closure burn down and number of Deviations and Waivers (DWs) approved/open).
- Review trends (Review Item Discrepancy (RID), Request for Action (RFA), and Action Item burn down per review).
- Software-unique trends (number of requirements per build/release versus plan).
- Problem Report/Discrepancy Report trends (number open and number closed).
- Cost trends (in plan, actual, UFE, Earned Value Management (EVM), and NOA).
- Schedule trends (critical path slack/float, critical milestone dates).
- Staffing trends (Full Time Equivalent (FTE) and Work Year Equivalent (WYE)).

- Technical Performance Measures (mass margin and power margin).
- Additional Project-specific indicators as needed.

These indicators are further explained in the “NASA Space Flight Program and Project Management Handbook” NASA/SP-2014-3705; the NASA Project Planning and Control Handbook, NASA/SP-2016-3424; and the NASA Common Leading Indicators Detailed Reference Guide at [https://nodis3.gsfc.nasa.gov/OCE\\_rep/OCE\\_list.cfm](https://nodis3.gsfc.nasa.gov/OCE_rep/OCE_list.cfm)

Describe the approach to monitor and control the Project’s Agency Baseline Commitment (ABC). Describe how the Project will periodically report performance. Describe mitigation approach if the Project is exceeding the development cost documented in the ABC to take corrective action prior to triggering the 30-percent breach threshold. Describe how the Project will support a baseline review in the event that the DA directs one.

Describe the Project’s implementation of TA (Engineering, Health and Medical, and SMA).

Describe how the Project will implement the Système Internationale (SI) and other systems of measurement and will identify units of measure in all product documentation. Where full implementation of the SI system of measurement is not practical, hybrid configurations (i.e., a controlled mix of SI and non-SI system elements) may be used to support maximum practical use of SI units for design, development, and operations. Where hybrid configurations are used, describe the specific requirements established to control interfaces between elements using different measurement systems. (See NPR 7120.5, Section 3.7, for the SI assessment timing requirement.)

Describe the Project’s implementation of EVM including:

- How the Performance Measurement Baseline (PMB) will be developed and maintained for the Project and how UFE will be established and controlled.
- The methods the Project will use to authorize the work and to communicate changes for the scope, schedule, and budget of all suppliers; a description of how the plan is updated as make-buy decisions and agreements are made.
- The process to be used by the Project to communicate the time-phased levels of funding that have been forecast to be made available to each supplier.
- For the class of suppliers not required to use EVM, the schedule and resource information required of the suppliers to establish and maintain a baseline and to quantify schedule and cost variances; a description of how contractor performance reports will be required.
- How the cost and schedule data from all partners/suppliers will be integrated to form a total Project-level assessment of cost and schedule performance.

Describe any additional specific tools necessary to implement the Project’s control processes (e.g., the requirements management system, Project scheduling system, Project information management systems, budgeting, and cost accounting system).

Describe the process for monitoring and controlling the IMS.

Describe the process for utilizing the Project’s technical and schedule margins and UFE to meet the Management and Commitment Baselines.

Describe how the Project plans to report technical, schedule, and cost status to the program manager, including the frequency and level of detail of reporting.

Describe the Project's internal processes for addressing technical waivers and deviations and handling Formal Dissents.

Describe the Project's descope plans, including key decision dates and savings in cost and schedule; and show how the descopes are related to the Project's threshold performance requirements.

Include a description of the systems engineering organization and structure and how the Project Chief Engineer (CE) executes the overall systems engineering functions.

### **3.2 Safety and Mission Assurance Plan**

**Recommend as a stand-alone plan. Project cost and scope should be small to justify not having a separate plan.**

Develop a project Safety and Mission Assurance (SMA) Plan as required by NPR 8705.2, Human-Rating Requirements for Space Systems for crewed missions and NPR 8705.4, Risk Classification for NASA Payloads for un-crewed missions and payloads.

The SMA Plan reflects a project life-cycle SMA process perspective, addressing areas including: SMA domain management and SMA domain integration (e.g., for safety, reliability, maintainability, quality, planetary protection, etc.) with other engineering and management functions (e.g., concept and design trade-studies, risk analysis and risk assessments, risk-informed decision making, fault tolerance and contingency planning, knowledge capture, hardware and software design assurance, supply chain risk management and procurement, hardware and software design verification and test, manufacturing process design and control, manufacturing and product quality assurance, system verification and test, pre-flight verification and test, operations, maintenance, logistics planning, maintainability and sustainability, operational reliability and availability, decommissioning, and disposal). The plan reflects a Project life-cycle SMA process perspective, addressing areas including procurement, management, design and engineering, design verification and test, software design, software verification and test, manufacturing, manufacturing verification and test, operations, and preflight verification and test.

Identify the project's approach to flow down requirements as appropriate to external developers and suppliers in acquisitions (e.g., contracts and purchase orders).

Describe how the project will develop, evaluate, and report indications of SMA program maturity and effectiveness at life cycle or other executive reviews, including through the use of metrics and indicators that are not otherwise included in formal life-cycle review deliverables or are not elements of the certification of flight readiness process (e.g., satisfactory progress towards human rating).satisfactory progress towards human rating).

### **3.3 Risk Management Plan**

**Can tailor to include in PP using tailoring tools**

***Note: Project cost and scope should be small to justify not having a separate plan. Suggest consulting with a Risk Management specialist for the best approach.***

Develop a Risk Management Plan that includes the content required by NPR 8000.4, Agency Risk Management Procedural Requirements. Summarize how the Project will implement a risk

management process (including Risk-Informed Decision Making (RIDM) and Continuous Risk Management (CRM) in accordance with NPR 8000.4). Include the initial Significant Risk List and appropriate actions to mitigate each risk. Projects with international or other U.S. Government agency contributions need to plan for, assess, and report on risks due to international or other Government partners and plan for contingencies.

### 3.4 Acquisition Plan

**Can tailor to include in PP using tailoring tools.**

***Note: Project cost and scope should be small to justify not having a separate plan.***

The Project Acquisition Plan is developed by the PM, supported by the host Center's Procurement Officer, and needs to be consistent with the results of the Agency strategic acquisition process and ASM. It documents an integrated acquisition strategy that enables the Project to meet its mission objectives and provides the best value to NASA. The Acquisition Plan should include, but is not limited to, the following:

Identify all major proposed acquisitions (such as engineering design study, hardware and software development, mission and data operations support, and sustainment) in relation to the Project WBS. Provide summary information on each such proposed acquisition, including a contract WBS; major deliverable items; recommended type of procurement (competitive or an Announcement of Opportunity (AO) for instruments); type of contract (cost-reimbursable or fixed-price); source (institutional, contractor, other U.S. Government agency, or international organization); procuring activity; and surveillance approach. Identify those major procurements that require a Procurement Strategy Meeting (PSM).

Describe completed or planned studies supporting make-or-buy decisions, considering NASA's in-house capabilities and the maintenance of NASA's core competencies, as well as cost and best overall value to NASA.

Describe the supply chain and identify potential critical and single-source suppliers needed to design, develop, produce, support, and, if appropriate, restart an acquisition program or Project. The Acquisition Plan should promote sufficient Project stability to encourage industry to invest, plan, and bear their share of risk. Describe the internal and external mechanisms and procedures used to identify, monitor, and mitigate supply chain risks. Include data reporting relationships to allow continuous surveillance of the supply chain that provides for timely notification and mitigation of potential risks. Describe the process for reporting supply chain risks to the program.

Identify the Project's approach to strengthen SMA in contracts.

Describe all agreements, memoranda of understanding (MOUs), barter, in-kind contributions, and other arrangements for collaborative and/or cooperative relationships. Include partnerships created through mechanisms other than those prescribed in the Federal Acquisition Regulation (FAR) and NASA FAR Supplement (NFS). List all such agreements (the configuration control numbers, the date signed or projected dates of approval, and associated record requirements) necessary for Project success. Include or reference all agreements concluded with the authority of the PM and reference agreements concluded with the authority of the Program Manager and above. Include the following:

- (1) NASA agreements (e.g., space communications, launch services, inter-Center memoranda of agreement).

- (2) Non-NASA agreements:
  - (a) Domestic (e.g., U.S. Government agencies).
  - (b) International (e.g., MOUs).

Describe intellectual property considerations and goals for advanced technologies to protect core NASA interests during the project life cycle; the process for respecting and protecting privately developed intellectual property; the process for ensuring acquisition strategies, proposals, and contract awards reflect intellectual property considerations established for the project; the approach for ensuring that the intellectual property strategy promotes competition for post-production sustainment/modernization contracts; the approach for seeking flexible and creative solutions to intellectual property issues that meet the desires of the parties and reflect NASA's investment; the approach for ensuring procurement contracts specify both (1) the delivery of necessary technical data and computer software and (2) the license rights necessary for technical data and computer software; and the approach for ensuring the delivery of technical data and computer software under procurement contracts is marked in accordance with the contract at the time of delivery.

### 3.5 Technology Development Plan

**This plan is considered a best practice under NPR 7120.5 and is not required.**

**Can tailor to include in PP using tailoring tools.**

***Note: Project cost and scope should be small to justify not having a separate plan.***

Describe the technology assessment, development, management, and acquisition strategies needed to achieve the Project's mission objectives.

Describe how the Project will assess its technology development requirements, including how the Project will evaluate the feasibility, availability, readiness, cost, risk, and benefit of the new technologies.

Describe how the Project will identify opportunities for leveraging ongoing technology efforts.

Describe how the Project will transition technologies from the development stage to the manufacturing and production phases. Identify the supply chain needed to manufacture the technology and any costs and risks associated with the transition to the manufacturing and production phases. Develop and document appropriate mitigation plans for the identified risks.

Describe the Project's strategy for ensuring that there are alternative development paths available if/when technologies do not mature as expected. (Refer to NPR 71237123.1 for Technology Readiness Level (TRL) definitions.)

Describe how the Project will remove technology gaps, including maturation, validation, and insertion plans, performance measurement at quantifiable milestones, off-ramp decision gates, and resources required.

Describe briefly how the Project will ensure that all planned technology exchanges, contracts, and partnership agreements comply with all laws and regulations regarding export control and the transfer of sensitive and proprietary information.

Describe how the project will transition technologies from the development stage to manufacturing, production, and insertion into the end system. Identify any potential costs and

risks associated with the transition to manufacturing, production, and insertion. Develop and document appropriate mitigation plans for the identified risks.

### **3.6 Systems Engineering Management Plan**

**Can tailor to include in PP using tailoring tools.**

*Note: Project cost and scope should be small to justify not having a separate plan.*

Develop a stand-alone SEMP that includes the content required by NPR 7123.1. Include descriptions of the project's overall approach for systems engineering to include system design and product realization processes (implementation and/or integration, verification and validation, and transition), as well as the technical management processes. Reference the stand-alone plan here.

### **3.7 System Security Plan**

**Use the following generic wording unless there is a specific need to generate a plan**

The Project will follow the policies and procedures set forth in GLPD 2810.1, Glenn Procedural Requirements (GLPR) 1440.1, and NPR 2210.1, which meet the Agency requirements to acquire and use IT. These documents were reviewed, and no special processes in relation to the Project were identified to be required.

Identify and prepare a System Security Plan for each information system. The System Security Plan is a formal document that provides an overview of the security requirements for an information system and describes the security controls in place or planned for meeting those requirements.

System Security Plans are generated and stored within the NASA Risk Information and Security Compliance System (RISCS) at [https://nasa.sharepoint.com/sites/RISCS\\_C](https://nasa.sharepoint.com/sites/RISCS_C) . Multiple systems may be covered under a single System Security Plan. Controls selected within the System Security Plan are included as system requirements for the system or systems covered by the plan.

Document the project's approach to implementing cybersecurity requirements in accordance with NPR 2810.1, Security of Information and Information Systems, if there are requirements outside the scope of the System Security Plan(s).

### **3.8 Software Management Plan**

**Can tailor to include in PP using tailoring tools.**

*Note: Project cost and scope should be small to justify not having a separate plan.*

Develop a Software Management Plan that includes the content required by NPR 7150.2, Software Engineering Requirements. Additional information on the plan can be found in NASA-STD-8739.8, Software Assurance and Software Safety Standard. Summarize how the project will develop and/or manage the acquisition of software required to achieve project and mission objectives. The Software Management Plan should be coordinated with the Systems Engineering Management Plan.

### 3.9 Verification and Validation Plan

**Can tailor to include in PP using tailoring tools.**

*Note: Project cost and scope should be small to justify not having a separate plan.*

Summarize the approach for performing verification and validation of the Project products. Indicate the methodology to be used in the verification and validation (test, analysis, inspection, or demonstration), as defined in NPR 7123.1.

### 3.10 Review Plan

**Can tailor to include in PP using tailoring tools.**

*Note: Project cost and scope should be small to justify not having a separate plan. A detailed review plan can also be included in the SEMP.*

Summarize the Project's approach for conducting a series of reviews, including internal reviews and Project LCRs. In accordance with Center best practices, program review requirements, and the requirements in NPR 7123.1 and NPR 7120.5, provide the names, purposes, content, and timing of the LCRs.

Identify any deviations from these documents that the Project is planning or waivers that have been granted. Provide the technical, scientific, schedule, cost, and other criteria that will be utilized in the consideration of a Termination Review.

For projects that plan continuing operations and production, including integration of capability upgrades, with an unspecified Phase E end point, define the initial capability in the Review Plan for KDP B if the initial capability is not the first operational mission flight.

For Projects that are part of tightly coupled programs, Project LCRs and KDPs should be planned in accordance with the Project life cycle and KDP sequencing guidelines in the PP. Document the sequencing of each Project LCR and KDP with respect to the associated Program LCR and KDP. In addition, document which Project KDPs should be conducted simultaneously with the KDPs of other Projects and which Project KDPs should be conducted simultaneously with the associated program KDPs.

The sequencing of Project LCRs and KDPs with respect to program LCRs and KDPs is especially important for Project Preliminary Design Review (PDR) LCRs that precede KDP Cs. At KDP C, the Agency makes Project technical, cost, and schedule commitments to its external stakeholders at the established JCL in accordance with the requirements of NPR 7120.5. Because changes to one Project can easily impact the technical, cost, schedule, and risk baselines of other Projects, Projects and their program may need to proceed to KDP C/KDP I together.

### 3.11 Mission Operations Plan

**Can tailor to include in PP using tailoring tools.**

*Note: Project cost and scope should be small to justify not having a separate plan.*

Describe the activities required to perform the mission. Describe how the Project will implement the associated facilities, hardware, software, and procedures required to complete the mission. Describe mission operations plans, rules, and constraints. Describe the Mission Operations System (MOS) and Ground Data System (GDS) in the following terms:

- MOS and GDS human resources and training requirements.

- Procedures to ensure that operations are conducted in a reliable, consistent, and controlled manner using lessons learned during the program and from previous programs.
- Facilities requirements (offices, conference rooms, operations areas, simulators, and test beds).
- Hardware (ground-based communications and computing hardware and associated documentation).
- Software (ground-based software and associated documentation).

### 3.12 NEPAN EPA Compliance Documentation

#### Use generic wording unless there is a specific need to generate a plan

GRC has reviewed the Project requirements and processes and coordinated with all partners to ensure compliance with NPR 8580.1. GRC follows GLPD 8500.1, and GLPR 8553.1, which complies with NPR 8580.1. A separate plan is not required.

Describe the level of NEPA analysis planned to comply with NPR 8580.1, Implementing the National Environmental Policy Act, and Executive Order 12114. The NEPA Compliance Documentation should be prepared based on consultation with the appropriate NEPA manager (Center NEPA Manager or Mission Direction NEPA Liaison) and describe the project's NEPA strategy at all affected Centers, including decisions regarding programmatic NEPA documents. Insert into the project schedule the critical NEPA milestones if preparation of an Environmental Assessment or Environmental Impact Statement is planned.

### 3.13 Integrated Logistics Support Plan

#### Can tailor to include in PP using tailoring tools.

*Note: Project cost and scope should be small to justify not having a separate plan.*

Describe how the Project will implement NPD 7500.1, including a maintenance and support concept; participation in the design process to enhance supportability; supply support; maintenance and maintenance planning; packaging, handling, and transportation; technical data and documentation; support and test equipment; training; manpower and personnel for Integrated Logistics Support (ILS) functions; facilities required for ILS functions; and logistics information systems for the life of the Project.

### 3.14 Science Data Management Plan

**This plan is considered a best practice under NPR 7120.5 and is not required.**

#### Can cite Configuration Management (CM) Plan.

Describe how the project will manage the scientific data generated and captured by the operational mission(s) and any samples collected and returned for analysis. Include descriptions of how data will be generated, processed, distributed, analyzed, and archived, as well as how any samples will be collected, stored during the mission, and managed when returned to Earth. The Plan should include definition of data rights and services and access to samples, as appropriate. Identify where the preliminary science data requirements will be documented (these requirements should be documented by SRR). The Plan should be developed in consultation with the Directorate data leads and the Office of the Chief Information Officer (OCIO) early in the project life-cycle to ensure that metadata standards and data formats are appropriately considered and that infrastructure and security requirements are addressed.

Explain how the project will accomplish the information management and disposition in NPD 2200.1, Management of NASA Scientific and Technical Information; NPR 2200.2, Requirements for Documentation, Approval and Dissemination of Scientific and Technical Information; and NPR 1441.1, NASA Records Management Program Requirements, as applicable to project science data.

Explain how the project will implement NASA sample handling, curation, and planetary protection directives and rules

### **3.15 Integration Plan**

Prepare an Integration Plan that defines the integration and verification strategies for a Project interface with the system design and decomposition into the lower-level elements. The Integration Plan is structured to bring the elements together to assemble each subsystem and to bring all the subsystems together to assemble the system/product. The primary purposes of the integration plan are: (1) to describe this coordinated integration effort that supports the implementation strategy, (2) to describe for the participants what needs to be done in each integration step, and (3) to identify the required resources and when and where they will be needed.

### **3.16 Configuration Management**

**Can tailor to include in PP using tailoring tools.**

***Note: Project cost and scope should be small to justify not having a separate plan.***

Describe the configuration management (CM) approach that the project team will implement. Describe the CM planning and management function including the CM organization and tools to be used. Describe the methods and procedures to be used for configuration identification, configuration control, interface management, configuration change management, configuration verification and audit, and configuration status accounting and communications. Describe how CM will be audited and how contractor CM processes will be integrated with the project. Configuration Management should address hardware, software, and firmware. Additional information on configuration management is provided in NPR 7123.1 and SAE/EIA 649, Standard for Configuration Management.

### **3.17 Security Plan**

**Use the following generic wording unless there is a specific need to generate a plan**

The ***Project Name*** provides protection for any sensitive and accountable classified documents/materials/information, working documents, or by-products commensurate with the assigned classification level and prevents unauthorized persons from gaining access during its use, dissemination, storage, movement or transmission. However, there are no sensitive or classified documents identified by the Project. Facility access and physical security is provided to the Project by the NASA Glenn Research Center. Personnel background investigations and security awareness/education (e.g., information and technology, export control, counterterrorism, etc.) are provided as necessary by the Office of Protective Services at the respective participating centers. Information Technology (IT) security services are provided by the IT Security Office. All security processes and procedures ***shall*** be implemented in accordance with NASA and participating Center's security policies and requirements:

- NPR 2810.1, Security of Information and Information Systems
- NPR 2800.1, Managing Information Technology

- NPD 2810.1, NASA Information Security Policy
- NPR 1600.1, NASA Security Program Procedural Requirements
- NPD 1600.2, NASA Classified National Security Information (CNSI)

All program documentation/information **shall** be maintained electronically on a central server, with periodic backups, and retained in accordance with NPR 1441.1, NASA Records Management Program Requirements.

Weather- or facility-related emergencies are announced via GRC’s emergency siren system, telephone broadcast message system, and/or broadcast e-mail system. For other types of emergencies, the **Project Name shall** follow the emergency policies and directives of GRC and other participating centers. After normal duty hours, emergency instructions are provided through the news media. All emergency response procedures and processes are implemented in accordance with the emergency policies and requirements of NASA and participating centers:

- NPR 1040.1, NASA Continuity of Operations (COOP) Planning Procedural Requirements
- NPD 1040.4, NASA Continuity of Operations (COOP)

Physical and IT Security for the Project is the responsibility of the implementing organization.

The Project **shall** identify and control threats to personnel and hardware through the use of access controls and other safeguards and **shall** establish appropriate security procedures that meet the intent of NPR 1600.1. Each team member **shall** protect the integrity, availability, and confidentiality of **Project Name** information systems, software applications, data, and information generated in a manner that meets the intent of NPR 2810.1 and NPD 2810.1. Finally, the Project **shall** establish the appropriate emergency response protocols in accordance with the approved processes at the appropriate institution.

The **Project Name** personnel, who may be CSs, contractors, and partners regardless of location, **shall** comply with information, physical, personnel, and industrial counterintelligence/counterterrorism and security awareness/education requirements in accordance with NPR 1600.1.

The **Project Name** will not have its own physical security personnel. The security personnel of the participating Center will be the primary focal point for physical security issues. Any Project requirements and responsibilities will be coordinated with the appropriate GRC security personnel. Personnel, facilities, critical assets, and information protection and identification of potential threats and other vulnerabilities **shall** be performed in compliance with all NASA security requirements.

The **Project Name** will comply with NASA Information Technology (IT) security requirements per NPD 2810.1, and NPR 2810.1.

All **Project Name** team members—civil service and contractor—are charged with the responsibility for ensuring a safe and healthful workplace in accordance with NPR 1040.1, “NASA Continuity of Operations (COOP) Planning Procedural Requirements.”

Every employee, without fear of disciplinary action or any form of retaliation, is required to notify a line manager or supervisor, or the SMA Office, of any hazardous condition that may

cause or result in employee injury/illness or that may cause equipment and/or property damage. When an unsafe condition or work practice presents imminent danger to personnel or equipment/property, all CS and contractor employees are vested with the right to, and are obligated to, stop the work and then contact a line manager or supervisor, or the SMA Office.

Describe the Project's plans for ensuring security and technology protection, including:

**Security Requirements:** Describe the Project's approach for planning and implementing the requirements for information, physical, personnel, industrial, and counterintelligence/counterterrorism security and for security awareness/education requirements in accordance with NPR 1600.1 and NPD 1600.2. Include in the plan provisions to protect personnel, facilities, mission-essential infrastructure, and critical Project information from potential threats and other vulnerabilities that may be identified during the threat and vulnerability process.

**Emergency Response Requirements:** Describe the Project's emergency response plan in accordance with NPR 1040.1 and define the range and scope of potential crises and specific response actions, timing of notifications and actions, and responsibilities of key individuals.

### 3.18 Project Protection Plan

Ensure that a Project Protection Plan is completed according to the schedule identified in product maturities, as documented in Appendix I of NPR 7120.5

The project Protection Plan is approved by the Mission Directorate's designated approval authority, and the implementing Center's engineering Technical Authority.

The Project Protection Plan assesses applicable adversarial threats to the project or system (including support systems, development environments, and external resources), identifies system susceptibilities, potential vulnerabilities, countermeasures, resilience strategies, and risk mitigations. The results inform the project's or system's design and concept of operations, in context with the project's or system's requirements. The Project Protection Plan addresses NASA-STD-1006, Space System Protection Standard, in accordance with NPR 1058.1, NASA Enterprise Protection Program, and includes inputs from threat intelligence, candidate protection strategies provided by OCE, and other applicable standards. The project team assesses adversarial threats with support from the Office of Protective Services' Intelligence Division and the Office of the Chief Engineer and requires access to Classified National Security Information.

Since protection measures can be implemented either by designing the project's or system's architecture to be more resilient or by enhancing the capabilities provided by institutional security providers, it is important that the document identify to institutional security providers (both internal and external to NASA) the critical nodes and single points-of-failure in the project or system. The project System Security Plan (see Section 3.7 above) and Security Plan (see Section 3.17) should address how institutional security measures are implemented on each project to protect its critical nodes.

Risk scenarios emerging from the project Protection Plan analysis are tracked in accordance with the project's Risk Management Plan. (See Section 3.3 above.)

Project Protection Plans provide technical information on NASA space systems to specific commands and agencies in the Department of Defense and Intelligence Community to assist those organizations in providing timely support to NASA in the event of an incident involving a NASA mission.

### 3.19 Technology Transfer Control Plan

**Use the following generic wording unless there is a specific need to generate a plan**

The *Project Name* will comply with the export control policies and requirements specified in NPR 2190.1, “NASA Export Control Program.” The NASA Export Control Program (ECP) ensures that exports and transfers to foreign parties in international activities are consistent with Export Administration Regulations (EAR), International Traffic in Arms Regulations (ITAR), and NASA international activities. The NASA Headquarters Export Administrator (HEA), Center Export Administrator, Export Counsel *Project Name*, Project Manager, *Project Name* team members, and Transportation Officers are the key personnel charged with ensuring that the Project complies with U.S. export control laws and regulations. The *Project Name* has no direct Technical Assistance Agreements (TAAs) or MOUs with any foreign entities. If such contracts or agreements are established in the future, the Project *shall* coordinate these activities with the NASA HEA and the GRC Center Export Representative (CER) and *shall* comply with the requirements of NPR 2190.1. In addition, under U.S. law and regulation, spacecraft and their specifically designed, modified, or configured systems, components, parts, etc., are generally considered “Defense Articles” on the U.S. Munitions List and are, therefore, subject to the provisions of ITAR.

Describe how the Project will implement the export control requirements specified in NPR 2190.1.

### 3.20 Knowledge Management (KM) Plan

**This plan is considered a best practice under NPR 7120.5 and is not required.**

Describe the project’s approach to creating the KM strategy and processes. Strategy should include practices for identifying, capturing and transferring knowledge and capturing and documenting LL throughout the project life cycle as authorized in NPD 7120.4, NASA Engineering and Program/Project Management Policy and as described in NPD 7120.6, Knowledge Policy for Programs and Projects and other appropriate requirements and standards documentation.

### 3.21 Human Rating Certification Package

**Typically not applicable for GRC Projects**

For human space flight missions, develop a Human Rating Certification Package per NPR 8705.2. Human rating certification focuses on the integration of the human into the system, preventing catastrophic events during the mission, and protecting the health and safety of humans involved in or exposed to space activities, specifically the public, crew, passengers, and ground personnel.

### 3.22 Planetary Protection Plan

**Typically not applicable for GRC Projects**

Prepare a plan that specifies management aspects of the planetary protection activities of the Project. Planetary protection encompasses: (1) the control of terrestrial microbial contamination associated with space vehicles intended to land, orbit, flyby, or otherwise encounter extraterrestrial solar system bodies, and (2) the control of contamination of the Earth by extraterrestrial material collected and returned by missions. The scope of the plan contents and level of detail will vary with each Project.

### 3.23 Nuclear Safety Launch Approval Plan

#### Typically not applicable for GRC Projects

Prepare a nuclear safety launch approval plan for any U.S. space mission involving the use of radioactive materials. Procedures and levels of review and analysis required for nuclear launch safety approval vary with the quantity of radioactive material planned for use and potential risk to the general public and the environment. NPR 8715.3 specifies the procedural requirements for characterizing and reporting potential risks associated with a planned launch of radioactive materials into space, on launch vehicles and spacecraft, and during flight.

### 3.24 Range Flight Safety Risk Management Process Documentation

Develop documentation that details a vehicle program's Range Flight Safety Risk Management process in accordance with NPR 8715.5. This applies to launch and entry vehicle programs, scientific balloons, sounding rockets, drones, and Unmanned Aircraft Systems. This does not apply to programs developing a payload that will fly onboard a vehicle. The range flight safety concerns associated with a payload are addressed by the vehicle's range flight safety process. The focus is on the protection of the public, workforce, and property during range flight operations.

### 3.25 Payload Safety Process Deliverables

Develop the payload safety process deliverables in accordance with NPR 8715.7. This applies to uninhabited orbital and uninhabited deep space payloads that fly onboard Expendable Launch Vehicles and are managed by NASA, whether developed by NASA or any contractor or independent agency in a joint venture with NASA. The focus is on payload design, fabrication, testing, vehicle integration, launch processing, launch, and planned recovery; payload-provided upper stages; interface hardware that is flown as part of a payload; and Ground Support Equipment used to support payload-related operations. NASA Technical Standard (NASA STD) 8719.24 provides more details on payload processing for launch.

### 3.266 Communications Plan

**This plan is considered a best practice under NPR 7120.5 and is not required.**

**Can tailor to include in PP using tailoring tools.**

***Note: Project cost and scope should be small to justify not having a separate plan.***

Develop a Communications Plan in collaboration with the Associate Administrator for the Office of Communications or their designee that identifies key project milestones that will be of interest to the general public, the media, and other key stakeholders and plans to engage these audiences via audio and real and/or near real-time high-resolution video and/or imagery for each milestone including during full mission operations. Summarize how these efforts will promote understanding of and engagement with project objectives, elements, benefits, and contributions to overarching NASA goals. In collaboration with the Associate Administrator for the Office of Communications or their designee, identify resources and technical requirements for implementation of communications for the general public, media, and other key stakeholders. (See the Communications Plan Template (on the Web site for the Office of Communications, <http://communications.nasa.gov/content/nasa-comm-guidelines>

### **3.27 Quality Assurance Surveillance Plan**

Develop a consolidated set of detailed instructions for the performance of Government contract quality assurance review and evaluation for the project. The plan might include contractor documents, data, and records; products and product attributes; processes; quality system elements/attributes; and requirements related to quality data analysis, nonconformance reporting and corrective action tracking/resolution, and final product acceptance. (See NASA-STD-8709.22, Safety and Mission Assurance Acronyms, Abbreviations, and Definitions.)

### **3.28 Orbital Collision Avoidance Plan**

Describe how the project implements the design considerations and preparation for operations to avoid in-space collisions. The plan ensures the space flight mission meets the requirements of NID 7120.132, Collision Avoidance for Space Environment Protection. Include in the plan a project overview including a concept of operation, how orbit selection was performed, the spacecraft's ascent and descent plan, how the spacecraft's location tracking data will be generated, and whether there will be any autonomous flight control. Discuss how the spacecraft's design will enable it to be acquired and tracked by the Space Surveillance Network and be cataloged by the U.S. Space Command. Describe the process to routinely coordinate with other operator(s) for maneuvering. Appendix C of the NID provides a template for this plan. (See NID 7120.132, Collision Avoidance for Space Environment Protection for more detail and plan template.)

### **3.29 Human Systems Integration Plan**

Develop a Human Systems Integration (HSI) Plan that describes how human systems integration and human centered design will be integrated into the project design process and life cycle, including what types of human systems integration resources, tools, analysis, testing, and products will be employed or developed to ensure successful human systems integration, thereby reducing mission risk and total life cycle or initial capability cost, while increasing overall safety. The plan also describes roles and responsibilities related to implementation of HSI. (See the NASA Human Systems Integration (HSI) Handbook, NASA/SP-20210010952, for additional information.)

## **4.0 WAIVERS OR DEVIATIONS LOG**

Identify NPR 7120.5 requirements for which a waiver or deviation has been requested and approved consistent with project characteristics such as scope, complexity, visibility, cost, safety, and acceptable risk, and provide rationale and approvals.

## **5.0 CHANGE LOG**

Track and document changes to the Project Plan.

## **6.0 APPENDICES**

**Appendix A. Acronyms**

**Appendix B. Definitions**

**Appendix C. Compliance Matrix for this NPR**

## **APPENDIX G. External Support Agreement Template**

Acronyms in the appendix are defined in Appendix B. The form for External Support Agreement (GRC 2050) can be found in The NASA Electronic Forms System (NEF) <https://nef.nasa.gov/>

## **APPENDIX H. Project Milestone Products Maturity Matrix**

Acronyms in the appendix are defined in Appendix B. See NPR 7120.5, Table I-4 Project Milestone Products Maturity Matrix and Table I-5 Project Plan Control Plans Maturity Matrix

## **APPENDIX I. Project Control Board Charter Template**

The PCB Charter Template can be found in the GRC Business Management System (BMS).

The form for Project Control Board Directive Template (GRC 2066) can be found in The NASA Electronic Forms System (NEF) <https://nef.nasa.gov/>

*The following are basic elements the cover should contain.*

# **[PROJECT NAME] PROJECT CONTROL BOARD CHARTER**

***[short title or acronym]***

Effective Date: Month 00, 201X

Revision: Baseline

## **CHANGE HISTORY**

<b>Rev./Change</b>	<b>Date</b>	<b>Description/Comments</b>

**<PROJECT/TASK NAME>**  
**Project Control Board (PCB) Charter**  
Revision <draft>

## **1.0 PURPOSE**

Define the purpose for this charter, for example, “To establish the project PCB in accordance with GLPR 7120.5.10, “Project Management Requirements and Best Practices”....”

## **2.0 APPLICABILITY**

Identify either the GRC internal management authority Project Office that this project reports to, for example, “This charter is applicable to NASA GRC Project, which is managed by the SFS Directorate/SFS Division Office on behalf of the NASA Program/Project”; or the external customer Program or Project Office that it reports to.

Identify the triggers for holding the PCB.

## **3.0 AUTHORITY**

Briefly describe the control board hierarchy with the Project and program (internal and external to GRC) that are involved in reaching final approved decisions from this PCB. A figure depicting these relationships should also be provided.

Lower-level boards should also be described, along with their programmatic and technical authority relationships to the PCB, such as the Project/Task ERB or MRB.

## **4.0 MEETING FREQUENCY**

Describe the plan for regularly scheduled PCB meetings or state that they will be called upon on an as-needed basis.

## **5.0 MEMBERSHIP**

Identify the standing membership of the PCB, call out specifically the PCB Chair, PCB Executive Officer, C/DM, and other board members from Project/Task team leadership, such as the CE, CSO, PI, IM, and the CAMs, as appropriate or desired by the PM.

Identify ability to invite ad hoc members (driven by agenda topic).

## **6.0 RESPONSIBILITIES**

Identify the roles of the PCB Chair, PCB Executive Officer, C/DM, and board members.

State if a board member(s) cannot attend a PCB so that an alternate can be chosen as a replacement.

## **7.0 OPERATING PRINCIPLES**

Define how decisions are made on the PCB. Note that it is GRC practice to have the PCB Chair (Program/Project Manager) make the decision based on input from the board.

Identify the PCB Directive, where purpose, member votes, Formal Dissents, actions, and decisions/recommendations are recorded, as an official record for the PCB. See the PCB Directive template in APPENDIX I of GLPR 7120.5.10.

## 8.0 FORMAL DISSENTS AND APPEALS PROCESS

Describe the Formal Dissents and appeals process for the project PCB. A figure depicting these relationships can be provided. Reference GRC Engineering and SMA Formal Dissent process, with citation to the GLPR 7120.5.10, Section 2.7, as the starting point.

All “no” votes do not necessarily trigger the appeals process. If a PCB member disagrees with the decision of the PCB Chair, their vote can be cast as a “no” vote and the rationale supporting that vote is recorded on the PCB Directive. It is at the discretion of the dissenter whether to enact GRC’s Formal Dissent and Appeals Process.

## 9.0 RECORDS

Define records that should be generated as part of the project files because of the PCB, that is, completed PCB Directive, Action Log, archive of presentation, and all supporting material used during the PCB.

PREPARED BY:

---

Project Manager  
Full name

---

Date

APPROVED BY:

---

Director of SFS or designee  
Full name

---

Date

## Change History

Revision/Change	Date	Description/Comments
Basic	4/9/10	New document replacing Glenn Interim Directive (GLID) 7120.5.10
Rev. A	4/16/14	Update in response to NASA Procedural Requirements (NPR) 7120.5, is rewritten and replaces Glenn Procedural Requirement (GLPR) 7120.5.40, GLPR 7120.5.42, and GLID 7120.5.44.
Change 1	6/11/2015	Administrative changes: Updated to reflect governance changes and performed minor editing for clarification in Sections 2.6.2 and 3.3.3.3a 91) and (2). Removed Figures 3.30 and 3.31.
Change 2	6/16/2015	Administrative change: Updated Table 3.1 and Table of Content
Change 3	2/17/2017	Administrative changes: Updated to correct errors, add mission directorate support definition, correct references, removed numbering from appendices containing acronyms and definitions, align with current charters and clarify guidance.
Change 4	2/04/2019	Administrative Changes: <ul style="list-style-type: none"> <li>-Per GLPR 1410.1, Expiration date extended one year</li> <li>-Updated cited documents in P.3 and P.4 to meet current format and content requirements, including removing quotation from document titles (NPR 1400.1, 3.3.2).</li> <li>-Removed applicable document GLPR 9410.1 and citation in Section 3.4.3.3</li> </ul>
Change 5	7/30/2020	Revalidation with Administrative Changes: <ul style="list-style-type: none"> <li>-Updated documents in P.4 to add/remove documents since the last update and citations throughout the document.</li> <li>-Updated Table 2.2 to be consistent with GLPR 7123.35.</li> <li>-Added 3.3.7.3 d to better clarify Decision Authority delegation to close CPAR MB002020031601.</li> <li>-Modified 3.4.14.3 a to clarify that formal signatures are not required to close life-cycle reviews for Bronze and Silver projects.</li> <li>-Modified Appendix F.3 Section 1.4 to describe the Decision Authority delegation path.</li> <li>-Modified Appendix F.3 Sections 3.4 and 3.7 with updates provided by GRC IT security.</li> </ul>
B	6/04/2025	Updated to meet new requirements in NPR 7120.5F 2.1d Clarified SAR and PSR requirements Formatted to meet current requirements of GLPR 1410.1
Change 1	5/01/2026	Minor administrative edits to letter/number(s) in Appendices C.4 Matrix and Appendix E