



Chapter Glossary .....	2
11.0 Ground Data Systems & Mission Operations .....	303
11.1 Introduction .....	303
11.2 Ground Systems Architecture .....	304
11.2.1 Types of Communication Infrastructures .....	305
11.3 Frequency Considerations.....	306
11.3.1 Frequency Selection: Link Budget.....	307
11.3.2 Frequency Licensing.....	307
11.4 Ground Segment Services.....	308
11.4.1 Ground Networks – NASA and Partners.....	310
11.4.2 Ground Segment as a Service (GSaaS).....	317
11.4.3 Space Relay Network - NASA.....	328
11.4.4 Low Latency, Low Rate (Short Burst) Space Relay Providers .....	329
11.5 Ground Stations Components.....	330
11.5.1 Ground Station Operation .....	330
11.5.2 Component Hardware for Ground Systems (GS) .....	332
11.5.3 Ground Software .....	337
11.6 Mission and Science Operations Centers.....	341
11.6.1 Software for Mission Operations .....	343
11.7 End-to-End Communications and Compatibility Testing .....	345
11.7.1 End-to-End Hardware for Ground Systems .....	345
11.8 Cyber Security.....	350
11.9 State-of-the-Art – Ground Data and Supporting Systems .....	352
11.9.1 Technologies .....	352
11.9.2 Ground Aggregators .....	354
11.9.3 Scheduling and Mission Operations Software.....	356
11.10 On the Horizon.....	361
11.10.1 Free Space Optical Communications .....	361
11.10.2 Optical Ground Stations and Future Infrastructure Requirements.....	363
11.10.3 Techniques to Improve Optical Comm Reliability .....	368
11.10.4 Role of Optical Relays .....	370
11.11 Summary .....	370
References .....	371



## Chapter Glossary

(API)	Application Programming Interface
(ASGS)	ASRF SmallSat Ground Station
(ASRF)	Atmospheric Sciences Research Facility
(AWS)	Amazon Web Services
(C-STIS)	Celestia Satellite Test & Simulation BV
(C2)	Command & Control
(CCSDS)	Consultative Committee for Space Data Systems
(CFDP)	CCSDS File Delivery Protocol
(CDMA)	Code Division Multiple Access
(CPAW)	Collection Planning and Analysis Workstation
(CRC)	Cooperative Centre
(CS)	Commercial Services
(CSP)	CubeSat Space Protocol
(DIU)	Department of Defense's Defense Innovation Unit
(DLR)	German Aerospace Center
(DoD)	Department of Defense
(DSN)	Deep Space Network
(DSOC)	Deep Space Optical Communications
(DSS-17)	Deep Space Station-17
(DTE)	Direct-to-Earth
(DVB-S2)	Digital Video Broadcast Satellite Second Generation
(EDUs)	Engineering Development Units
(EGSE)	Electrical Ground Support Equipment
(EIRP)	Effective Isotropic Radiated Power
(ESA)	European Space Agency
(ESOC)	European Space Operations Centre
(FCC)	Federal Communications Commission
(FDMA)	Frequency Division Multiple Access
(FEP)	Front End Processors
(FFRDCs)	Federally Funded Research and Development Centers
(GBPA)	Ground-Based Phase Array
(GEO)	Geosynchronous Equatorial Orbit
(GNSS)	Global Navigation Satellite System
(GPS)	Global Positioning System
(GSOC)	Global Security Operations Center
(GSFC)	Goddard Space Flight Center
(GUI)	Graphic User Interface
(HEO)	Highly Elliptical Orbit
(HF)	High Frequency



(HPAs)	High-Power Amplifiers
(I&T)	Integration and Test
(IARU)	International Amateur Radio Union
(IC)	Intelligence Community
(IDL)	Interactive Data Language
(IMEI)	International Mobile Equipment Identity
(INCOSE)	International Council on Systems Engineering
(INNOVA)	IN-orbit and Networked Optical Ground Stations Experimental Verification Advanced Testbed
(ISAN)	Integrated Space Access Network
(ISO)	International Organization for Standardization
(ISS)	International Space Station
(ITOS)	Integrated Test and Operations System
(ITU)	International Telecommunications Union
(JPL)	Jet Propulsion Laboratory
(KSAT)	Kongsberg Satellite Services AS
(KSC)	Kennedy Space Center
(LADEE)	Lunar Atmosphere and Dust Experiment Explorer
(LCRD)	Laser Communications Relay Demonstration
(LDT)	Lowell Discovery Telescope
(LEOP)	Launch and Early Orbit Phase
(LLCD)	Lunar Laser Communications Demonstration
(LNA)	Low-Noise Amplifier
(MCS)	Mission Control Software
(MEO)	Medium Earth Orbits
(MOC)	Mission Operations Center
(MSFC)	Marshall Space Flight Center
(MSPA)	Multiple Spacecraft Per Aperture
(NEN)	Near Earth Network
(NSN)	Near Space Network
(NICT)	National Institute of Information and Communications Technology
(NIMO)	Networks Integration Management Office
(NIST)	National Institute of Standards and Technology
(NORAD)	North American Aerospace Defense Command
(NTIA)	National Telecommunications and Information Administration
(OCTL)	Optical Communications Telescope Laboratory
(OGS)	Optical Ground Stations
(PNT)	Position Navigation and Timing
(PPM)	Pulse Position Modulation
(PPP)	Public-Private Partnership
(PPS)	Precise Positioning System



(RBAC)	Role Based Access Control
(R&D)	Research and Development
(RF)	Radio Frequency
(RTE)	Real-Time Earth
(RTSR)	Real Time Space Relay
(SA)	Single Access
(SDR)	Software Defined Radio
(SETH)	Science Enabling Technology for Heliophysics
(SFCG)	Space Frequency Coordination Group
(SMA)	S-band multiple access
(SN)	Space Network
(SNSPD)	Superconducting Nanowire Single Photon Detector
(SOC)	Science Operations Center
(SPD-5)	Space Policy Directive 5
(SSBV)	Satellite Services B.V.
(SSC)	Swedish Space Corporation
(SWaP)	Size, Weight, and Power
(TDMA)	Time-Division Multiple Access
(TDRS)	Tracking and Data Relay Satellites
(TDRSS)	Tracking and Data Relay Satellite System
(TLE)	Two-Line Element set
(TNC)	Terminal Node Controller
(TNO)	The Netherlands Organization
(TOGS)	Transportable Optical Ground Station
(TT&C)	Telemetry, Tracking and Control
(UHF)	Ultra-High Frequency
(USRP)	Universal Software Radio Peripheral
(VHF)	Very high frequency
(VICTS)	Variable Inclination Continuous Transverse Stub
(VMs)	Virtual Machines
(WFF)	Wallops Flight Facility
(XTCE)	XML Telemetric and Command Exchange



## 11.0 Ground Data Systems & Mission Operations

### 11.1 Introduction

The ground segment is a critical part of the end-to-end science data return, and it includes all the ground-based elements that are used to collect and disseminate information from the satellite to the user (Figure 11.1). The primary elements of a ground system are summarized in Table 11-1.

There are exciting changes in the government and commercial sector ground stations and services, and the shifting synergy between these. From its inception in 1958, whenever NASA needed to receive data from one of its Earth observing satellites or talk to its astronauts in orbit, it used equipment and services it had needed to develop and build itself. Over time, commercial enterprise acquired the proficiencies necessary to reliably and securely communicate with objects in low-Earth orbit (LEO), services NASA is now pursuing to purchase as any other near-Earth space customer.

The agency combined NASA’s Near Earth Network (NEN) and NASA’s Space Network (SN) into NASA’s Near Space Network (NSN) in October of 2020. To support the commercialization initiative, NASA plans to have increased reliance on industry-provided communications services for missions close to Earth by 2030 (59). As of 2024, commercial providers do not service the Sun-Earth Lagrange Points or Deep Space, thus the Deep Space Network (DSN), and large NSN assets (18 m) continue to play a critical and needful role in returning science data from these regions for Heliophysics, Astrophysics and Planetary Science directorates.

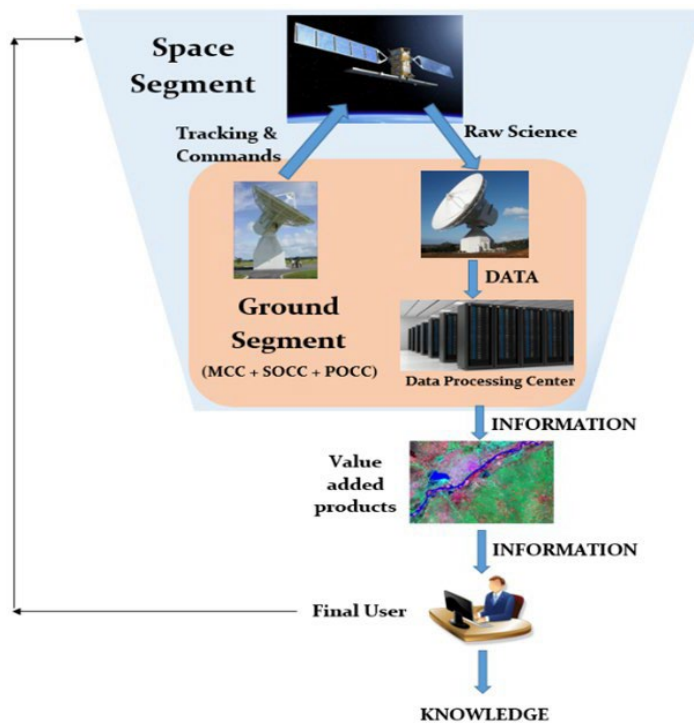

Figure 11.1: Functional relationship between the space segment, ground segment and final user for a small satellite mission. Credit: NASA.

<b>Element</b>	<b>Function</b>
Ground Stations	Telemetry, tracking, and command interface with the spacecraft
Ground Networks	Connection between multiple ground elements
Control Centers	Management of the spacecraft operations
Remote Terminals	User interface to retrieve transmitted information for additional processing

The NSN provides Direct-to-Earth (DTE) services via a global system of commercial and NASA-owned ground stations that provide line of sight communications and tracking services to missions ranging from low-Earth orbit and extending to Sun-Earth Lagrange Points 1 & 2. These services



are augmented by Space Relay services via relay satellites in geosynchronous orbit.

The ground segment design can depend on several factors which may include, but are not limited, to the following:

- Data volume to satisfy mission requirements
- Location of the ground assets relative to mission orbit parameters
- Budget limitations
- Distribution of the team
- Affiliation of who controls the spacecraft (federal vs. non-federal users)
- Regulatory requirements
- Latency requirements

The ground system is responsible for collecting and distributing the most valuable asset of the mission: the data. Using the proper ground system is key to mission success.

All small satellites use some form of a ground segment to communicate with the spacecraft, whether it be hand-held radios using an amateur frequency, or a large dish pulling down data on a non-federal or federal frequency. The commercial marketplace for Telemetry, Tracking and Commanding (TT&C) services continues to expand and has reached a maturity to enable commercialization of Direct-to-Earth (DTE) radio frequency communications services. NASA is encouraging a growing commercial market by leveraging commercial capabilities to increase efficiency and robustness of ground networks. In addition, NASA plans to enhance its communications capabilities to provide near-continuous communications support to the Artemis lunar missions through Communication Relay and Navigation services in Lunar space.

## 11.2 Ground Systems Architecture

A typical small satellite mission has the following elements within the ground system architecture:

- Ground Station Terminal: Transmitter and receiver or transceiver at the ground station to transmit and receive information, including related hardware such as antennas. These may be in a Radio Frequency (RF) or in an optical wavelength.
- Mission Operations Center (MOC):
  - Commands the spacecraft
  - Monitors spacecraft performance
  - Requests and retrieves data as necessary
- Science Operations Center (SOC):
  - Generates and disseminates science data products
  - Determines science operations to be relayed to the MOC
- Ground Station Data Storage and Network:
  - Provides live connectivity to a MOC for commands and telemetry
  - Temporarily stores data to be retrieved by the MOC and/or SOC

Figure 11.2 shows a generic small satellite ground architecture that uses NASA's Near Space Network (NSN) for nominal ground passes and the NASA Space Network (SN) for low-latency messaging.

In this architecture, the MOC is responsible for all communication to and from the spacecraft,

while the SOC and engineering teams can work both directly through the MOC to process commands. This is especially helpful during commissioning and troubleshooting instances where the engineering team needs direct access to the flight system. This architecture also provides a

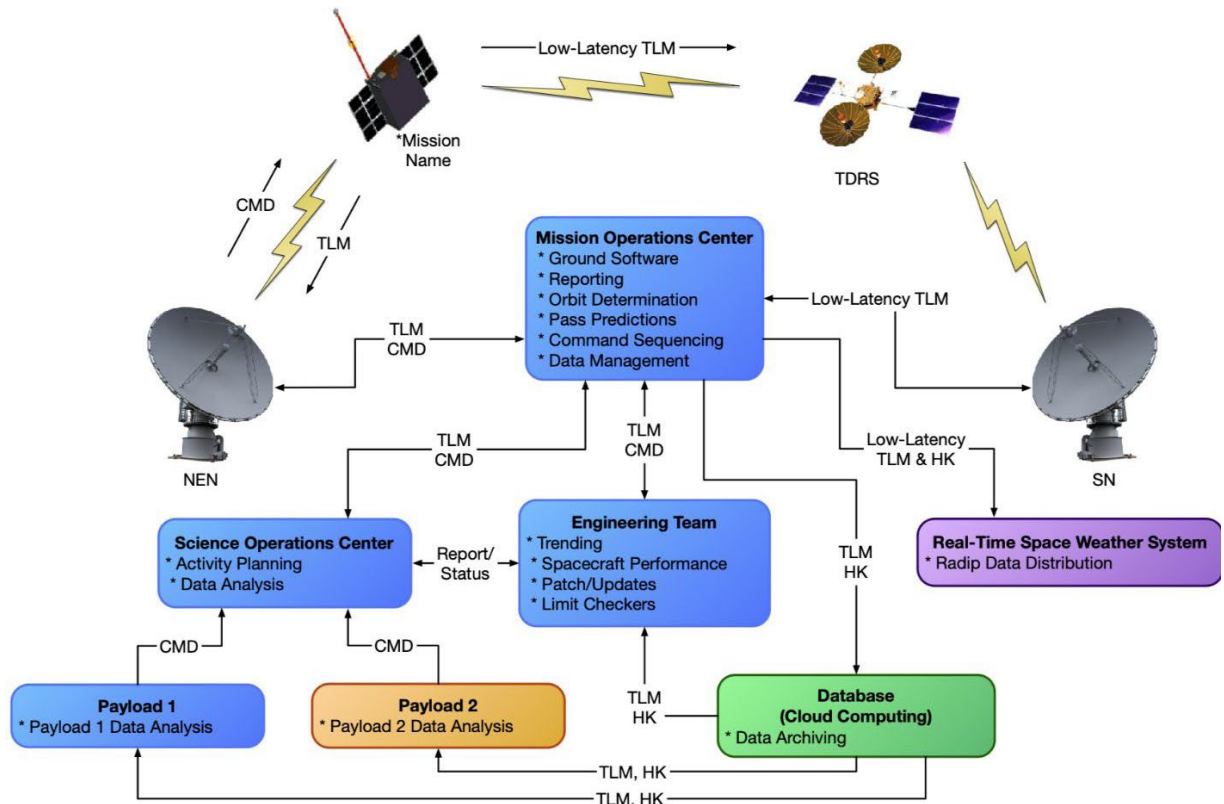

Figure 11.2: Example of a ground system architecture for a small satellite using NASA's Near Space Network. Credit: NASA.

separate database generated from the MOC of telemetry and housekeeping data that is accessible to stakeholders.

### 11.2.1 Types of Communication Infrastructures

Communications services may be either Direct-to-Earth (DTE) or augmented by space relay. DTE ground stations provide direct point-to-point access with antennas at ground stations which are strategically located and equipped with telemetry, command, and tracking services. DTE antennas for NASA small satellites are high gain parabolic dish antennas used to support S, X, and Ka bands, while some universities still use parabolic or UHF Yagi antennas. DTE ground stations could also incorporate phased array antenna systems or equipment for optical communications. The DTE services are especially effective for missions needing frequent, short-duration contacts with high data throughput. They are also capable of handling longer latency durations due to orbital dynamics and station visibility.

Space relay services involve an intermediate satellite that communicates with a ground station on the Earth's surface. Relay communication satellites for low-Earth orbit spacecraft can be in Geosynchronous Equatorial Orbit (GEO), about 36,000 km from Earth, or in low-Earth orbit. Relays are essential for providing communication and tracking when direct-to-ground communications are not feasible due to physical asset visibility constraints. It is common for a low-Earth orbit spacecraft to only be in a DTE ground station's line of sight for a portion of the orbit. The addition of space-based relay assets can provide missions with full-time coverage and continuous access to





communication and tracking services. They are most useful for missions that need continuous coverage, low latencies, and coverage of launch, critical events, or emergencies.

Communication with DTE ground stations can achieve much higher data rates than what is possible for space-based relays. When considering a GEO relay satellite, it can be ten times the distance from the low-Earth orbit spacecraft than the DTE ground station. With communication propagation losses being a function of the reciprocal of the distance squared, the same communications system can achieve orders of magnitude higher data rates with the DTE ground station. Achieving comparative data rates for a relay system would require a significant increase in power. The current low-Earth orbit relays have hardware limitations that permit data rates of 9.6 kbps or less, which is low relative to SmallSats being able to achieve 3 Mbps or more with DTE ground stations.

### 11.3 Frequency Considerations

The spacecraft transceiver and ground station need to be on a coordinated frequency to communicate. Selecting transmit and receive frequencies are a critical part of the spacecraft communications system design process. Frequencies are divided into different bands as shown in Table 11-2. See a list of supported frequencies per ground station in their specific sections.

Typical bands considered for small satellites and therefore ground stations are Ultra High Frequency (UHF), S, X, and Ka. UHF was the band of choice for early small satellites, but in recent years, there has been a shift to S and X and Ka. A ground station needs to maintain antennas and receivers such that the ground receive matches the space segment's transmit frequency and vice versa. Since Transmit (Tx) and Receive (Rx) have different key drivers and requirements, many ground stations are dual or tri-band.

<b>Band</b>	<b>Frequency</b>
HF	3 to 30 MHz
VHF	30 to 300 MHz
UHF	300 to 1000 MHz
L	1 to 2 GHz
S	2 to 4 GHz
C	4 to 8 GHz
X	8 to 12 GHz
Ku	12 to 18 GHz
Ka	27 to 40 GHz
V	40 to 75 GHz
W	75 to 110 GHz
mm	110 to 300 GHz

#### **Ground Station Receive (Spacecraft Return, Telemetry)**

Ground station receive frequencies are mostly S and X band from a LEO/ GEO orbit, and X and Ka band from deep space. Ka band has been implemented for transmit and is NASA's desired band for future small satellite missions. This shift has been driven by higher data return demands and frequency control. The higher frequencies permit more data to be transmitted over a given period but require more stringent pointing. UHF is appealing to some universities, due to the lower cost of hardware for both the spacecraft and ground station, good link margins, and more omni-directional pattern capability with the spacecraft but yields lower data rates and has a higher probability for interference. Higher frequencies provide wider bandwidths, and the matching antennas have narrower beamwidths or are arrayed for a higher gain, thus more stringent pointing is required.

#### **Ground Station Forward (Spacecraft Commanding)**

The key driver to successfully command a satellite from the ground, is the ability to reach it. The most critical period is after a satellite's release from the launch vehicle, at which point the satellite does not yet have full control over its attitude, thus the most important thing is a wide beamwidth for the spacecraft receiving antenna(s) in the selected frequency. For this reason, ground stations are designed with more power and Low Noise Amplifiers (LNA) to counter the low gain, ideally omni-directional single patch receive antennas in the lower frequency bands.





### 11.3.1 Frequency Selection: Link Budget

Calculating the RF link budget is the first step when designing a telecommunications solution. It is a calculation of the end-to-end performance of the communications link with the constraint of maintaining a required link margin. Maintaining a 3 dB link margin is adequate for data return from a satellite in low-Earth orbit at a slant range of 1,500 km. Usually commanding to a Near Earth orbit has plenty of margin because of the high power and aperture size of the ground station, and the lower required data rate on the account of the commands' low volume. When considering deep space communication, a 3 dB link margin is desired, but for distant spacecraft, such as New Horizons at 7 billion kilometers from Earth, 1 dB or less margin may be all that is practically possible. The budget calculation adds and subtracts all the power gains and losses that a communication signal will experience within the system. Factors such as uplink amplifier gain and noise, transmit antenna gain, slant angles and corresponding free space loss, satellite transceiver noise levels and power gains, receive antenna and amplifier gains and noise, cable losses, and atmospheric attenuation are considered. There is a duality to frequency effects: free space loss over the same range is less for lower frequencies; however, the wavelength is much smaller for higher frequencies, thus a same size ground aperture provides a much higher Gain over temperature (G/T). On the spacecraft end, a multi-element high-gain Ka-band antenna array for example fits in the palm of a hand. For high volume data return, which is where communications bottlenecks occur, higher frequencies are desirable – all the way up to optical wavelengths at 1550 nm (see section 11.10.1, *Free Space Optical Communications*).

### 11.3.2 Frequency Licensing

RF communication frequencies are intentionally protected. Within each frequency band there are government and non-government designations amongst the frequencies. Some frequencies are government use only, others are non-government only, and some are shared. Government bodies that regulate the frequency usage in the United States are the Federal Communications Commission (FCC) and the National Telecommunications and Information Administration (NTIA). Other countries may have their own national governing bodies, and all national bodies around the world must coordinate with the International Telecommunications Union (ITU), which is the governing body at the international level. The FCC is responsible for issuing communications licenses to non-government users and the NTIA handles government users. Licenses are required for both the satellite and ground station to transmit on a designated frequency or frequencies. It is becoming more common for small satellites to use multiple bands. For example, some missions have used UHF for uplink and S-band for downlink, while others have used S-band for uplink and X-band for downlink. Some of the non-government frequencies are dedicated for amateur usage.

Early university small satellites relied heavily on the use of amateur frequency bands. In recent years, there has been movement by the International Amateur Radio Union (IARU) and the FCC to significantly limit the use of amateur frequencies for small satellites. Those interested in using these frequencies are expected to first communicate their intention with the IARU and obtain a coordination letter prior to submitting an application with the FCC. It is recommended that missions with a new communication system design apply with the FCC or NTIA once an operations concept and a spacecraft design are defined, in order to verify a proper communications approach and associated hardware has been selected. Missions using a legacy communications approach can typically wait until they have been given a launch manifest. The licensing process can take several months and needs to be completed prior to launch. Some of the processing time is associated with the FCC and NTIA having to also coordinate with the ITU. Both the FCC and ITU are working to implement more streamlined small satellite licensing options. Such improvements will be necessary as constellations of small satellites become more prevalent.



## 11.4 Ground Segment Services

Ground segment services may include the below four categories. The NSN is a full-service ground station network and offers all four major service categories. Not all commercial services offer all services.

- 1) Mission Integration – this includes development of service agreements, interfaces, documentation, support of reviews, etc.
- 2) Mission Planning and Scheduling – this includes performing link and loading analyses, supporting service requests, and generating and implementing operational schedules.
- 3) User Mission Data Transfer – this includes primarily spacecraft forward command and return telemetry data.
- 4) Position, Navigation and Timing (PNT) – this includes navigation.

Position information (4) is critical for commanding the spacecraft (3). Commanding may be scripted by the mission and is actuated through ground services. Challenges are usually associated with the initial satellite-to-ground station link closure. Typically, two-line elements (TLE) or state vectors are established and shared by the launch provider after deployment. This information can be used to create an initial orbit solution for ground station antenna pointing. Low-Earth orbit missions can use North American Aerospace Defense Command (NORAD) TLE data (see <https://www.space-track.org>) for satellite location. However, it could take up to a week or more for NORAD to add the new object to their tracking list. This process could be delayed further if multiple spacecraft are ejected in close proximity, and it may not be clear which NORAD element set corresponds to which spacecraft. It is not uncommon to spend weeks attempting contact with different NORAD-tracked objects until the correct one is found. The position prediction accuracy based on the NORAD TLE also diverges over time and a new TLE will be needed to maintain data link. This is typically not an issue since the TLE is updated regularly, but on-board Global Positioning System (GPS) data (if equipped) can help determine the orbital parameters for the ground station to define latest orbital parameters.

Another method is to locate the satellite as it rises from the horizon. Ground station operators can point a directional antenna 5-10 degrees above the horizon to detect the satellite and synchronize with the radio. Most antenna tracking software will commence automatic tracking after the initial acquisition is successful. A half-duplex or full-duplex system could make a difference as well. Program track instead of auto-track is used for half-duplex. With a full-duplex system, the ground antenna attempts to acquire the downlink first. Predicts (NORAD or state vectors) are still used to initially acquire the spacecraft. If the predicts are off, the antenna can initiate a mechanical scan to increase the search area. Once the downlink is acquired, the ground antenna can auto-track and automatically point at the satellite for the duration of the pass. Additional passes are scheduled during spacecraft and payload commissioning. Table 11-3 describes NSN's transport and tracking capabilities.



<b>Table 11-3: NSN Interfaces and Capabilities</b>		
<b>Interface/ Capability<sup>1</sup></b>	<b>Direct to Earth</b>	<b>Space Relay</b>
<b>Terrestrial Link Data Transport Capabilities</b>		
Data Storage <sup>1</sup>	Station Storage: 5-30 days Cloud-based: Mission-driven	7 days
Network Data Rate <sup>1</sup>	Mission-driven (up to 1.2 Gbps)	
SLE Protocols	F-CLTU, EF-CLTU (Forward) RAF, RCF, ROCF (Return)	
SLE Versions Supported <sup>2</sup>	CCSDS 910.4, CCSDS 911.1, CCSDS 911.2, CCSDS 911.5, CCSDS 912.1, CCSDS 912.11, CCSDS 912.3, CCSDS 913.1	
Offline-Data Transfer	CFDP, SFTP	
Security	Trusted Networks (Access Controls, Firewalls, Authentications, etc.)	
<b>Spacecraft Navigation Tracking Capabilities</b>		
Radiometric Tracking Services <sup>1</sup>	Tone Ranging 1-way or 2-way Doppler Antenna Angle Data	Spread Spectrum Ranging 1-way or 2-way Doppler Antenna Angle Data
Radiometric Measurement Accuracy <sup>1</sup>	<u>Range:</u> S-band: < 5 meters, 1 $\sigma$ <u>Doppler (Range-Rate):</u> S-band 1-way: $\leq 30$ mm/s, 1 $\sigma$ S-band 2-way: $\leq 15$ mm/s, 1 $\sigma$ X-band 1-way: $\leq 7$ mm/s, 1 $\sigma$ Ka-band 1-way: $\leq 2$ mm/s, 1 $\sigma$ <u>Antenna Angles:</u> S: 0.03°, X: 0.05° Ka: 0.01° (auto), 0.05° (program)	<u>Range:</u> $\leq 2.73$ meters, 1 $\sigma$ <u>Doppler (Range-Rate):</u> 1-way $\leq 1.55$ mm/s, 1 $\sigma$ 2-way $\leq 3.1$ mm/s, 1 $\sigma$ <u>Antenna Angles:</u> $\leq 0.1^\circ$
Radar Tracking Service Bands	C-band (5.4-5.9 GHz) Single Object X-Band (10.499 GHz) Multi Object	N/A
Radar Tracking Loop Gain (dB)	C-Band: 212-245 (227 Typical) X-Band: 246 (nominal)	
Other <sup>1</sup>	Ground Antenna Slew Rate:	Time Transfer Measurement:
	Azimuth and Elevation: $\geq 10^\circ/\text{sec}$ ( $10^\circ/\text{sec}^2$ ) * Train: $\geq 5^\circ/\text{sec}$ ( $5^\circ/\text{sec}^2$ ) * WS1 18-m system $\geq 2^\circ/\text{sec}$ ( $1^\circ/\text{sec}^2$ )	User Spacecraft Clock Calibration System: $\leq \pm 5 \mu\text{s}$ Return Channel Time Delay: $\pm 25\%$ of a bit period

<sup>1</sup> Services and performance (Data Rates, EIRP, G/T, etc.) are not uniform across assets.

<sup>2</sup> Additional capabilities above those listed could be supported as well.

<sup>3</sup> NASA may consider adding technologies not currently on its roadmap.

<sup>4</sup> 2nd and 3rd Generation TDRS only.

Another critical time in the life of a spacecraft is commissioning; either commissioning of the spacecraft bus, or commissioning of science instruments, including in-space calibration. During



commissioning phases, additional time and support personnel are typically scheduled (1).

#### 11.4.1 Ground Networks – NASA and Partners

The ground stations, MOC, SOC, and the supporting infrastructure connecting them together, make up a ground network. Ground station antenna dish diameters, LNAs, frequency feeds, station gain over temperature (G/T) requirements are carefully selected for each network and are optimized for targeted ranges. NASA's NSN ground network provides services to satellites up to 2 million km range from Earth; NASA owns and JPL maintains the DSN for missions beyond two million km, including planetary.

At NASA's Goddard Space Flight Center, the Exploration and Space Communications (ESC) projects division oversees the operations, maintenance and advancement of the Space Communications and Navigation (SCaN) program office's NSN. Operating at a high-level of reliability and proficiency, the NSN provides communications and navigation services for missions within 2 million kilometers of our planet, bringing down an average of almost 30 Terabytes of critical data daily. Through space relays and ground-based assets, The NSN provides data delivery and satellite tracking services, empowering new discoveries about the universe and our home planet. JPL is responsible for managing and maintaining the DSN.

#### NASA Near Space Network

"The newly established NSN is more than just an aggregation of the NEN's and SN's space-based technologies, ground stations and antennas; it's the network through which NASA and other space users will now arrange for support services for their near-Earth missions. Critically, those support services may be provisioned through government or commercial network assets in a way that is seamless to users—a cornerstone in SCaN's effort to incorporate increasing levels of commercial service while ensuring mission needs are met." (2)

The NSN provides direct-to-earth telemetry, commanding, ground-based tracking, and data and communications services to a wide range of customers. The network consists of NASA, commercial, and partner S-band, X-band, and Ka-band ground stations supporting spacecraft in low-Earth orbit, GEO, Highly Elliptical Orbit (HEO), Lunar orbit, and Lagrange point L1/L2 orbit up to one million miles from Earth. The NSN supports multiple robotic and launch vehicle missions with NASA-owned stations and through cooperative agreements with interagency, international, and commercial services. Table 11-4 shows the radio frequencies that the NSN supports via the NTIA.

<b>Band</b>	<b>Function</b>	<b>Frequency Band (MHz)</b>
S Uplink	Earth to Space	2,025 – 2,110
X Uplink	Earth to Space	7,190 – 7,235 (Two NEN sites to 7,200)
S Downlink	Space to Earth	2,200 – 2,300
X Downlink	Space to Earth, Earth Exploration	8,025 – 8,400
X Downlink	Space to Earth, Space Research	8,450 – 8,500
Ka Downlink	Space to Earth	25,500 – 27,000

A comprehensive list of Forward and Return capabilities per frequency are in Table 11-5. Systems are compliant with most CCSDS recommendations. The NSN consists of geographically-

dispersed ground stations operated by NASA and its commercial partners (Figure 11.3).

### Government

- NASA's Alaska Satellite Facility, Fairbanks — Supports: S/X Band — Assets: 11.3m, 11m, 9.1m
- NASA's Kennedy Uplink Station — Supports: S-band - Assets: 6.1m
- NASA's Ponce de Leon Station — Supports: S-band - Assets: 6.1m
- NASA's Wallops Ground Station (GS), Virginia — VHF, S/X Band — Assets: 11m/5m
- NASA's White Sands GS, New Mexico — Supports: VHF, S/Ka Band — Assets: 18.3m
- NASA's White Sand Complex, New Mexico — Supports VHF, S/Ka Band — Assets: 11m
- NASA's McMurdo Ground Station, Antarctica — Supports: S/X Band — Assets: 10m
- Fairbanks Command and Data Acquisition Station (NOAA partnership), Gilmore



Figure 11.3: NSN Global Ground Station Locations. Credit: NASA

Creek, Alaska

### Commercial

- KSAT Singapore — Supports: S/X Band — Assets: 9.1m
- KSAT Svalbard, Norway — Supports: S/X Band — Assets: 11.3m/11.3m/13m
- KSAT TrollSat, Antarctica — Supports: S/X Band — Assets: 7.3m/7.3m
- KSAT Punta Arenas – Supports: S/X Band — Assets: 11.5m





- KSAT Inuvik -- Supports: S/X Band — Assets: 13m
- SANSA Hartebeesthoek, South Africa — Supports: S/X Band — Assets: 12m/10m
- SSC Kiruna, Sweden — Supports: S/X Band — Assets: 13m/13m
- SSC Santiago, Chile — Supports: S Band — Assets: 9m/12m/13m
- SSC Space US North Pole, Alaska — Supports: S/X Band — Assets: 5m/7.3m/11m/13m
- SSC Space US Dongara, Australia — Supports: S/X Band — Assets: 13m
- SSC Space US South Point, Hawaii — Supports: S/X Band — Assets: 13m/13m

<b>Table 11-5: NSN Direct to Earth Command and Telemetry Capabilities per Frequency</b>		
<b>Interface/ Capability<sup>1</sup></b>	<b>Direct to Earth</b>	<b>Space Relay</b>
<b>Forward (Command) Communications</b>		
Frequency Bands (Near-Earth Use)	S-band: 2025-2110 MHz X-band: 7190-7235 MHz	S-band: 2025-2110 MHz Ku-band: 13.775 GHz Ka-band: 22.55-23.55 GHz <sup>4</sup>
Maximum Bandwidth	S-band: 5 MHz X-band: 10 MHz	S-band: 6 MHz Ku-band: 50 MHz Ka-band: 50 MHz <sup>4</sup>
Forward Max Data Rate <sup>1,2</sup> (prior to encoding)	S-band: 5 Mbps X-band: 5 Mbps	S-band MA: 300 Kbps S-band SA: 4.2 Mbps Ku-band: 50 Mbps Ka-band SA: 50 Mbps <sup>4</sup>
Antenna System EIRP (dBW) <sup>1</sup>	S-band: 51-81 (56 Typical) X-band: 85-86	S-band MA: 42 <sup>4</sup> S-band SA: 48.5 <sup>4</sup> Ku-band SA: 48.5 <sup>4</sup> Ka-band SA: 63 <sup>4</sup>
Modulation <sup>2,3</sup>	PM, FM, PCM, PCM/PM, PCM/PSK/PM, BPSK, QPSK, OQPSK, UQPSK	Spread spectrum: BPSK or UQPSK Non-spread: BPSK, QPSK, OQPSK, PCM/PM, or PCM/PSK/PM
Encoding <sup>2,3</sup>	Uncoded, or LDPC ½ or 7/8	Uncoded, Rate ½ Conv., Reed-Solomon, Concatenated (½ Conv. + RS), LDPC ½ or 7/8
Polarization	Circular (LHC, RHC)	Circular (LHC, RHC) (LHC only for MA services)
<b>Return (Telemetry) Communications</b>		
Frequency Bands (Near-Earth Use)	S-band: 2200-2290 MHz X-band: 8025-8400 MHz X-band (SRS): 8450-8500 MHz Ka-band: 25.5 – 27 GHz <sup>4</sup>	S-band: 2200-2290 MHz Ku-band: 15.0034 GHz Ka-band: 25.25 – 27.5 GHz <sup>4</sup>
Maximum Bandwidth	S-band: 5 MHz X-band: 375 MHz X-band (SRS): 10 MHz Ka-band: 1500 MHz	S-band (MAR & SAR): 6 MHz Ku/Ka-band: 225 MHz <sup>4</sup> Ka-band (Wide): 650 MHz <sup>4</sup>





Return Max Data Rate <sup>1,2</sup> (prior to encoding)	<u>Rates will vary – examples:</u> S-band: 2.2 Mbps (PACE) X-band: 220 Mbps (ICESat-2) X-band (SRS): 13.1 Mbps (IRIS) Ka-band: 3.5 Gbps (NISAR)	S-band MA: 1 Mbps S-band SA: 14.1 Mbps Ku/Ka-band: 600 Mbps <sup>4</sup> Ka-band (Wide): 1200 Mbps <sup>4</sup>
Antenna System G/T (dBW) <sup>1</sup>	S-band: 19.1-29.6 (21 Typical) X-band: 30.5-37.8 (32 Typical) Ka-band: 38-45 (41.3 Typical)	S-band MA: 3.2 (for LEO) S-band SA: 9.5 (for LEO) Ku-band: 24.4 (for LEO) Ka-band: 26.5 (for LEO) <sup>4</sup>
Demodulation <sup>2,3</sup>	PM, FM, PCM, PCM/PM, PCM/PSK/PM, BPSK, QPSK, OQPSK, AQPSK, SQPN, 8PSK	Spread spectrum: BPSK or UQPSK Non-spread: BPSK, QPSK, OQPSK, PCM/PM, or PCM/PSK/PM
Decoding <sup>2,3</sup>	Uncoded, Rate ½ Conv. and/or Reed-Solomon, LDPC ½ or 7/8, or Turbo Rate ½	Uncoded, Rate ½ Conv., Reed-Solomon, Concatenated (½ Conv. + RS), LDPC ½ or 7/8, Rate 7/8 TPC
Polarization	Circular (LHC, RHC)	Circular (LHC, RHC) (LHC only for MA services)

<sup>1</sup> Services and performance (Data Rates, EIRP, G/T, etc.) are not uniform across assets.

<sup>2</sup> Additional capabilities above those listed could be supported as well.

<sup>3</sup> NASA may consider adding technologies not currently on its roadmap.

<sup>4</sup> 2nd and 3rd Generation TDRS only.

While NASA's NSN is often reserved for NASA-funded missions, other ground network options exist for non-government-funded satellite operators. One common option, especially amongst amateur operators, is to take advantage of the UHF and VHF amateur network around the world.

The NSN is exploring how to provide higher data rates for CubeSat missions with techniques such as Digital Video Broadcast Satellite Second Generation (DVB-S2). Higher data rates either increase science return or reduce the number of minutes per day of required ground station contacts. Higher data rates also enable mother-daughter small satellite constellations, where the mother spacecraft handles the communication with Earth for multiple daughter spacecraft. Functions such as Multiple Satellite per Aperture (MSPA) are planned to be implemented on the Lunar Exploration Ground Sites (LEGS) mission (see the State-of-the-Art section).

The NSN facilitates Commercial Services (CS) and negotiated a bulk-buy discount for all NASA missions. This allows for contacts on the NSN Contractor/University Operated and CS apertures to be at no-cost for NASA missions. The NSN does schedule CS in accordance with NASA mission-defined priority. The Networks Integration Management Office (NIMO) at NASA GSFC is the liaison for customers that wish to use NSN services. NIMO has a variety of services and capabilities available and can coordinate support from providers throughout NASA, other US agencies, US commercial entities, and foreign governments. Some of the services that NIMO can provide include:

- Requirements Development
- Communications Design Support & Guidance
- Optical Communications Analysis
- Network Feasibility Analysis
- Spectrum Management



- RF Compatibility Testing
- Launch Support

Network Feasibility Analysis includes determining NSN station loading as a function of the mission's priority and determining the availability of planned stations for the contacts requested. Prior to the mission deployment, the NSN commits to providing the requested stations and contact time as outlined in the network feasibility analysis.

*For new customer mission service requests please fill out the NSN Service Inquiry Form at: <http://go.nasa.gov/NSNServiceInquiry>.*

*If interested in more information on using the Near Space Network (NSN), please also refer to <https://esc.gsfc.nasa.gov/projects/NSN>.*

### NASA Deep Space Network

The DSN is optimized to conduct telecommunication and tracking operations with space missions in GEO. This includes missions at lunar distances, the Sun-Earth LaGrange points, and in highly elliptical Earth orbits, as well as missions to other planets and beyond. The DSN has supported, or is currently supporting, missions to the Sun as well as every planet in the Solar System (including dwarf planet Pluto). Two missions (Voyager I and Voyager II) have reached interstellar space and still communicate with the DSN. The DSN offers services to a wide variety of mission customers, as shown in Table 11-6.

<b>Customers</b>	<b>Mission Phases</b>
<ul style="list-style-type: none"> <li>• NASA</li> <li>• Other Government Agencies</li> <li>• International Partners</li> </ul>	<ul style="list-style-type: none"> <li>• Launch and Early Orbit Phase (LEOP)</li> <li>• Cruise</li> <li>• Orbital</li> <li>• In-Situ</li> </ul>
<b>Mission Trajectories</b>	<b>Frequency Bands</b> – Includes Near-Earth and Deep Space Bands, Uplink and Downlink, Command, Telemetry, and Tracking Services
<ul style="list-style-type: none"> <li>• Geostationary or GEO</li> <li>• HEO</li> <li>• Lunar</li> <li>• LaGrange</li> <li>• Heliocentric</li> <li>• Planetary</li> </ul>	<ul style="list-style-type: none"> <li>• S-Band (2 GHz)</li> <li>• X-Band (7, 8 GHz)</li> <li>• Ka-Band (26, 32 GHz)</li> </ul>

DSN services include:

- Command Services
- Telemetry Services
- Tracking Services
- Calibration and Modeling Services
- Standard Interfaces
- Radio Science, Radio Astronomy and Very Long Baseline Interferometry Services
- Radar Science Services
- Service Management



Custom and tailored DSN services can also be arranged for missions and customers. DSN-provided data services are accessed via well-defined, standard data and control interfaces:

- The CCSDS
- The Space Frequency Coordination Group (SFCG)
- The ITU
- The International Organization for Standardization (ISO)
- De facto standards widely applied within industry
- Common interfaces specified by the DSN

The use of data service interface standards enable interoperability with similar services from other providers.

Figure 11.4 shows the DSN antennas and their locations. Each DSN ground station in California (United States), Madrid (Spain), and Canberra (Australia) currently as of 2021 was



Figure 11.4: DSN antennas and their locations. Credit: NASA.



operating four 34 m Beam Wave Guide antennas and one 70 m antenna. By the late 2020s, this is planned to increase to include one 70 m plus four 34 m antennas at each DSN site.

The DSN supports RF testing using the following facilities:

- Development and Test Facility (DTF-21), located near NASA Jet Propulsion Laboratory (JPL)
- Compatibility Test Trailer (CTT-22), able to come to the spacecraft site

For more information on DSN, please see:

[https://www.nasa.gov/directorates/space-operations/space-communications-and-navigation-scan-program/scan-services-and-scheduling/](https://www.nasa.gov/directorates/space-operations/space-communications-and-navigation-scan-program/space-communications-and-navigation-scan-program/scan-services-and-scheduling/)

<https://deepspace.jpl.nasa.gov/about/commitments-office/>

<https://deepspace.jpl.nasa.gov>

### **Swedish Space Corporation**

Swedish Space Corporation (SSC) is a global provider of ground station services, including support to launch and early operations, on-orbit Telemetry, Tracking and Control (TT&C) and data downlink, and even lunar services (see <https://sscspace.com/>). The SSC Infinity Network is specifically designed for constellations of small satellites in low-Earth orbits. The global network provides TT&C and data download and delivery services to SmallSat operators, and customer interfaces consist of web-based portals for pass scheduling on 5-meter and smaller antennas. SSC Infinity also uses standard configurations and standardized ground system hardware, limiting the number of mission configurations to help keep costs lower for satellite operators.

Using ground services will generally require some degree of pre-coordination (or “onboarding”) between the operator and provider, which is usually done before launch. This will vary between providers but may include contracting mechanisms; frequency licensing and coordination between the operator and the provider; compatibility testing; and the sharing of mission and vehicle specific information to ensure the ground stations are properly configured for the operator to use. Once the onboarding process is complete, satellite operators can schedule passes between their satellite(s) and desired ground station(s) in advance (the time window varies for each provider). The schedules for each ground station are deconflicted based on scheduling priority, and all frequency and modulation adjustments for the satellite are completed in advance of the pass by the service provider.

## KSATLITE

The baseline of Kongsberg Satellite Services AS (KSAT)'s 3.7-meter KSAT<sup>LITE</sup> antennas provide X-band and S-band for downlink and S-band for uplink. KSAT operates over 100 KSAT<sup>LITE</sup> antennas at 15+ ground station sites across the globe, supporting over 1.5 million passes in 2023 alone. In addition, KSAT<sup>LITE</sup> offers a global Ka-band network capable of supporting missions with higher data rates. KSAT<sup>LITE</sup> is an extension of the existing KSAT ground station antenna network with lower costs, increased flexibility, and improved availability and pass selection. The KSAT



Figure 11.5: 2024 KSAT<sup>LITE</sup> ground network map. Credit: KSAT.

network has uniquely located polar stations in the Arctic and Antarctic regions, providing 100% availability on passes for spacecraft in polar orbit. The network also includes mid-latitude ground stations, providing access for diverse orbits and mission profiles.

Additionally, KSAT has a network of large aperture antennas that are purpose built for supporting missions in cis-lunar space and beyond. In 2023 KSAT invested in a network of three 20m LEGS-class antennas that will be placed around the globe to provide full coverage of the Moon, which will be fully operational by Q1 of 2027 (5). See Figure 11.5 for 2024 KSAT<sup>LITE</sup> ground network map.

### 11.4.2 Ground Segment as a Service (GSaaS)

Ground Station as a Service (GSaaS) is a managed service which enables customers to communicate, downlink, & process data from their satellites/spacecrafts on as a pay-as-you go basis without needing them to build their own satellite ground stations. These services are usually scalable and use edge cloud services as an intermediate for customers data (5) (6).



## AWS Ground Station

AWS Ground Station is a managed service (Figure 11.6.) that lets customers build ground segment architectures in the cloud to control their satellites, process satellite data, and scale satellite operations without having to worry about building or managing their own antenna infrastructure. Customers can stream satellite data from any of the AWS antennas to the Amazon Elastic Compute Cloud (EC2) for real-time processing or to directly store data in the Amazon Simple Storage Service (S3). Additionally, customers can easily integrate their space workloads with other AWS services in near real-time using Amazon's low-latency, high-bandwidth global network. For example, customers who downlink terabytes of data daily can easily access AWS services such as Amazon SageMaker to quickly derive useful information. Other AWS services include Amazon VPC, Amazon Rekognition, and Amazon Kinesis Data Streams. These services allow operators to reduce data processing and analysis times for use cases like weather prediction or natural disaster imagery from hours to minutes or seconds. This also enables

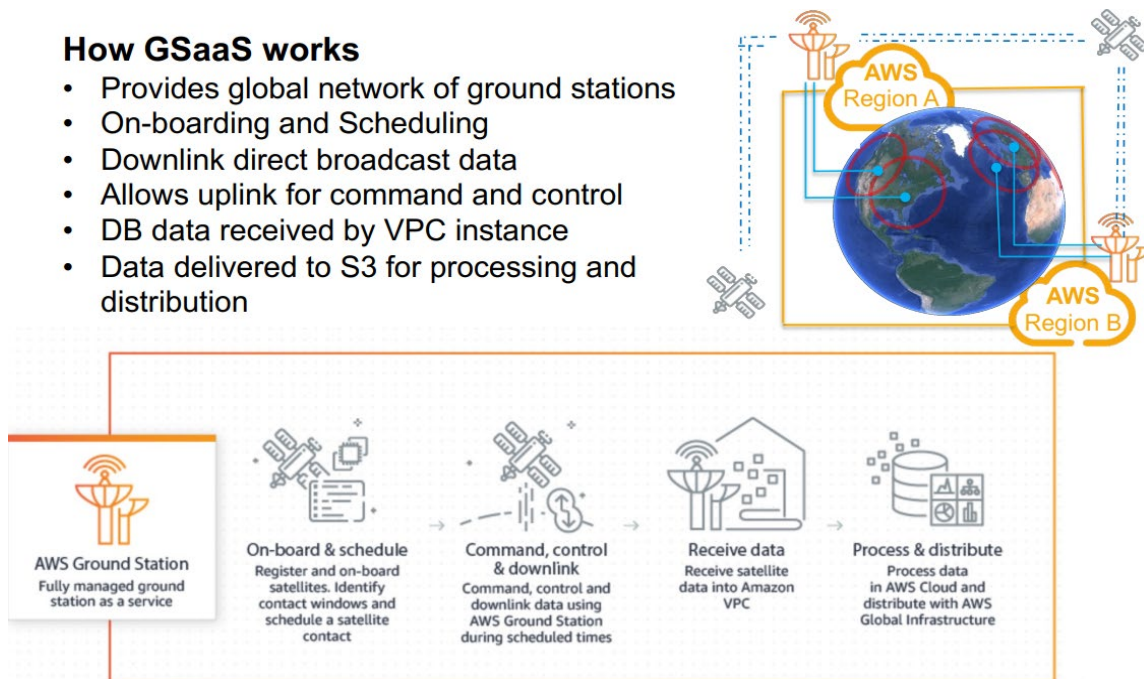

Figure 11.6. GSaaS Flow Chart. Credits: NASA/Amazon Web Services.

operators to quickly create business rules and workflows to organize, structure, and route the satellite data before it can be analyzed and incorporated into key applications such as imaging analysis and weather forecasting (8). A map of the AWS Ground Station antenna regions is shown in Figure 11.7.

AWS Ground Station offers 5.4-meter apertures at each of the antenna regions. AWS Ground Station provides satellite antennas direct access to AWS services for faster, simpler, and more cost-effective storage and processing of downloaded data. Frequencies and link parameters are as follows:

- S-band uplink: 2025-2120 MHz
- S-band downlink: 2200-2300 MHz with G/T of 16 dB/K
- X-band downlink: 7750-8400 MHz with G/T of 30.5 dB/K





AWS Ground Station antennas are interconnected via Amazon’s low-latency, highly reliable, scalable, and secure global network backbone. As of September 2024, the AWS Cloud spans 108 Availability Zones within 34 geographic regions around the world, with announced plans for 18 more Availability Zones and 6 more AWS Regions in Mexico, New Zealand, the Kingdom of Saudi Arabia, Thailand, Taiwan, and the AWS European Sovereign Cloud.



*Figure 11.7. AWS Ground Station Locations (2024). Credit: Amazon Web Services*

Customers have access to multiple billing structures including (1) pay-as-you-go (PAYG) option, where customers pay only for what they use on a per minute basis; (2) Dedicated Mission Support (DMS) option, where customers would receive schedule prioritization on one antenna for their constellation; (3) or Dedicated Antenna Solution (DAS) option, where AWS collaborates with customers to design a custom solution tailored to specific mission requirements, including support for specific spectrum bands, antenna apertures, and/or locations. The PAYG, DMS, and DAS solutions can also be combined for additional capacity needs.

**Scheduling:** AWS Ground Station provides an easy-to-use graphical console that allows operators to reserve contacts and antenna time for their satellite communications. They can review, cancel, and reschedule contact reservations up to 15 minutes prior to scheduled antenna times. Access can be scheduled to AWS Ground Station antennas on a per-minute basis, so operators only pay for the scheduled time. They can access any antenna in the ground station network, and there are no long-term commitments.

### **Viasat**

Viasat has delivered hundreds of ground antennas to NASA, other civilian space agencies, governments, and satellite industry partners throughout the world since the 1960s and has recently become a ground service provider. This move leverages decades of hardware engineering, with the global Real-Time Earth (RTE) network of ground terminals, complemented by a satellite relay network philosophy in GEO for low latency (near-real time) applications. A map of ground assets is shown in Figure 11.8. Viasat operates 7.3 m and 5.4 m antennas operating in 3 frequency bands (Table 11-7) (9) and plans to include 13m class antennas in the near future. The RTE ground segment service enables communications for next-generation and legacy LEO satellites using S, X, and Ka-bands. RTE offers downlinks from low megabits per second to multiple gigabits per second empowered by cutting edge software-defined radios at each site.

The service includes high-speed connectivity for backhaul, real-time data streaming, and real-time monitoring of overhead passes.



Figure 11.8: Viasat RTE global ground stations. Credit: Viasat.

Viasat's fully automated system allows users their choice of machine-to-machine or manual GUI-based scheduling over a highly resilient cloud-based platform. Instantaneous pass confirmation without human intervention lowers cost and risk of human error. Data is delivered to your choice of cloud provider, operations center, or government cloud destination. Viasat's Real Time Space Relay (RTSR) service is designed to allow LEO satellite operators to send data back to Earth in real time through the ViaSat-3 network of high-capacity Ka band GEO satellites. The RTSR service provides on-demand data delivery up to 50 GB/orbit without the need for a traditional ground station, enabling continuous custody of the spacecraft. It is designed to be available over the poles, oceans, and remote areas with persistent bi-directional connectivity to simultaneously serve/support hundreds, scalable to thousands, of LEO and non-LEO users and sensor platforms without pre-coordination or complicated scheduling/de-confliction algorithms. In partnership with NASA CSP, Viasat is developing a capability suite to address the full range of space missions called the Integrated Space Access Network (ISAN). ISAN is a one stop shop for multi-band, multi-path, secure connectivity solutions for on-orbit communications with unprecedented flexibility & capacity. Viasat is integrating the RTE ground solution with its relays for on-orbit demonstrations in 2026, allowing users to select between the low latency space relays and the high throughput global ground network (9). Viasat's L-band relay solutions are also designed to provide real-time, low-data latency communications. An additional part of Viasat's NASA CSP work includes the InCommand system, which will use Viasat's global L-band network to provide real-time telemetry, tracking and command (TT&C) operations at any point in the spacecraft's orbit. InCommand works in tandem with the RTSR system, offering a robust solution for on-demand satellite command and control. This service ensures continuous, real-time communication with GEO satellite infrastructure, facilitating rapid tasking and data transmission for LEO satellites.



<b>Location</b>	<b>Antenna</b>	<b>L-band Uplink</b>	<b>S-band Uplink</b>	<b>S-band Downlink</b>	<b>X-band Downlink</b>	<b>Ka-band Downlink</b>
Pendergrass, GA, USA (PGG)	5.4 m X-Y Full motion 5 °/sec max speed	N/A	2025-2110 MHz EIRP: 53.2 dBW Selectable RHCP or LHCP	2200-2290 MHz G/T: 17 dB/K Simultaneous RHCP and LHCP	8025-8400 MHz G/T: 30 dB/K Simultaneous RHCP and LHCP	N/A
Guildford, UK (GDD)	5.4 m X-Y Full motion 5 °/sec max speed	N/A	2025-2110 MHz EIRP: 53.2 dBW Selectable RHCP or LHCP	2200-2290 MHz G/T: 17 dB/K Simultaneous RHCP and LHCP	8025-8400 MHz G/T: 30 dB/K Simultaneous RHCP and LHCP	N/A
Alice Springs, AU (ASP01, ASP02)	7.3 m X-Y Full motion 6 °/sec max speed quantity 2	1755-1850 MHz EIRP: 63.4 dBW	2025-2110 MHz EIRP: 65.0 dBW Selectable RHCP or LHCP	2200-2290 MHz G/T: 18 dB/K Simultaneous RHCP and LHCP	8025-8400 MHz G/T: 32 dB/K Simultaneous RHCP and LHCP	25500-27000 MHz G/T: 34.5 dB/K Simultaneous RHCP and LHCP
Accra, Ghana (ACC)	7.3 m X-Y Full motion 6 °/sec max speed	1755-1850 MHz EIRP: 63.4 dBW	2025-2110 MHz EIRP: 65.0 dBW Selectable RHCP or LHCP	2200-2290 MHz G/T: 18 dB/K Simultaneous RHCP and LHCP	8025-8400 MHz G/T: 32 dB/K Simultaneous RHCP and LHCP	25500-27000 MHz G/T: 34.5 dB/K Simultaneous RHCP and LHCP
Cordoba, AR (COR)	5.4 m X-Y Full motion 5 °/sec max speed	N/A	2025-2110 MHz EIRP: 53.2 dBW Selectable RHCP or LHCP	2200-2290 MHz G/T: 17 dB/K Simultaneous RHCP and LHCP	8025-8400 MHz G/T: 30 dB/K Simultaneous RHCP and LHCP	N/A
Öjebyn, Sweden (OJY)	7.3 m X-Y Full motion 6 °/sec max speed	N/A	2025-2110 MHz EIRP: 55.2 dBW Selectable RHCP or LHCP	2200-2290 MHz G/T: 18 dB/K Simultaneous RHCP and LHCP	8025-8400 MHz G/T: 32 dB/K Simultaneous RHCP and LHCP	25500-27000 MHz G/T: 34.5 dB/K Simultaneous RHCP and LHCP
Pretoria, South Africa (PRY)	7.3 m X-Y Full motion 6 °/sec max speed	N/A	2025-2110 MHz EIRP: 55.2 dBW Selectable RHCP or LHCP	2200-2290 MHz G/T: 18 dB/K Simultaneous RHCP and LHCP	8025-8400 MHz G/T: 32 dB/K Simultaneous RHCP and LHCP	25500-27000 MHz G/T: 34.5 dB/K Simultaneous RHCP and LHCP



<b>Location</b>	<b>Antenna</b>	<b>L-band Uplink</b>	<b>S-band Uplink</b>	<b>S-band Downlink</b>	<b>X-band Downlink</b>	<b>Ka-band Downlink</b>
Obihiro, Japan (OBO)	7.3 m X-Y Full motion 6 °/sec max speed	N/A	2025-2110 MHz EIRP: 55.2 dBW Selectable RHCP or LHCP	2200-2290 MHz G/T: 18 dB/K Simultaneous RHCP and LHCP	8025-8400 MHz G/T: 32 dB/K Simultaneous RHCP and LHCP	25500-27000 MHz G/T: 34.5 dB/K Simultaneous RHCP and LHCP
North Pole Alaska USA 7.3 m (NTP01)	7.3 m Ei-Az-Train Ei & Az: 15 °/s max speed Train 6 °/s max	N/A	2025 – 2120 MHz EIRP: 53 dBW Selectable RHCP or LHCP	2200–2300 MHz G/T: 19 dB/K Simultaneous RHCP and LHCP	8000–8500 MHz G/T: 32 dB/K Simultaneous RHCP or LHCP	N/A
North Pole Alaska USA (9.1 m (NTP02))	9.1 m Ei-Az-Train	N/A	2042–2052 MHz EIRP 38 dBW Selectable RHCP or LHCP	N/A	8000–8500 MHz G/T: 34 dB/K RHCP	N/A
Tierra del Fuego, Argentina (USH)	7.3 m Ei-Az-Train Ei & Az: 15 °/s max speed Train 6 °/s max	N/A	2025-2110 MHz EIRP: 55.2 dBW Selectable RHCP or LHCP	2200-2290 MHz G/T: 17.9 dB/K Simultaneous RHCP and LHCP	8025-8400 MHz G/T: 32 dB/K Simultaneous RHCP and LHCP	25500-27000 MHz G/T: 34.7 dB/K Simultaneous RHCP and LHCP (Upgrade required)
Dubai, UAE	9.1 m Ei-Az-Train		2025-2110 MHz EIRP 38 dBW Selectable RHCP or LHCP	2200-2290 MHz G/T: 20 dB/K Simultaneous RHCP and LHCP	8025-8400 MHz G/T: 34 dB/K Simultaneous RHCP and LHCP	N/A

\*Denotes antenna redundancy

## Leaf Space

Leaf Space is a ground-segment-as-a-service provider, operating a globally distributed ground station network to support satellites of any size in low-Earth (LEO), Medium-earth (MEO) and Geostationary (GEO) orbits. Leaf Space's Leaf Line network (see Figure 11.9) enables TT&C and payload data transmissions to and from the satellite operators' mission control software and cloud platform of choice. Leaf does so via a simple API interface, a proprietary autonomous scheduling software, and global coverage of ground stations, supporting satellites in every LEO orbit – mid, high, equatorial-inclination. Leaf Line antennas are fully owned or fully managed, ensuring maximum availability, flexibility, and independence of operations. Leaf Line is powered and



orchestrated by a secure cloud architecture designed to support multiple satellite missions and operators at the same time. The network's secure architecture allows seamless use of any antenna without requiring any further resource overheads or worrying about varying performance over different ground stations. Leaf Space works closely with its customers to execute both routine operations and complex tasks such as LEOP or custom CONOPS.

Leaf Line consists of 3.7m and 3.9m diameter antennas and supports operations in S-band uplink (2025-2110 MHz, EIRP: 50 dBW), S-band downlink (2200-2290 MHz, G/T: 12.8 dB/K), X-band downlink (8025-8500 MHz, G/T: 25.4 dB/K), and Ka-band downlink (25.5-27 GHz, G/T: 30.0 dB/K). The network includes a limited UHF (400.15-403 MHz) support capability as well. Leaf Space is expanding its ground station network in terms of sites, capacity, and antenna performances to cater to a wide variety of customers. With an eye towards the future of the sector, Leaf Space is working to integrate larger-aperture antennas for upcoming GEO missions, optical ground systems as well as cislunar-oriented solutions to its existing network.

In addition to providing access to the Leaf Line network, Leaf Space also procures, deploys and operates dedicated and/or custom ground stations for its customers (service offering called Leaf Key), enabling operators with non-standard frequencies, access or data requirements to leverage Leaf Space's cloud architecture and ground segment experience without compromising on antenna time. For more information on the company or on how Leaf Space can support current and future missions, please contact [sales@leaf.space](mailto:sales@leaf.space) or visit <https://leaf.space>.

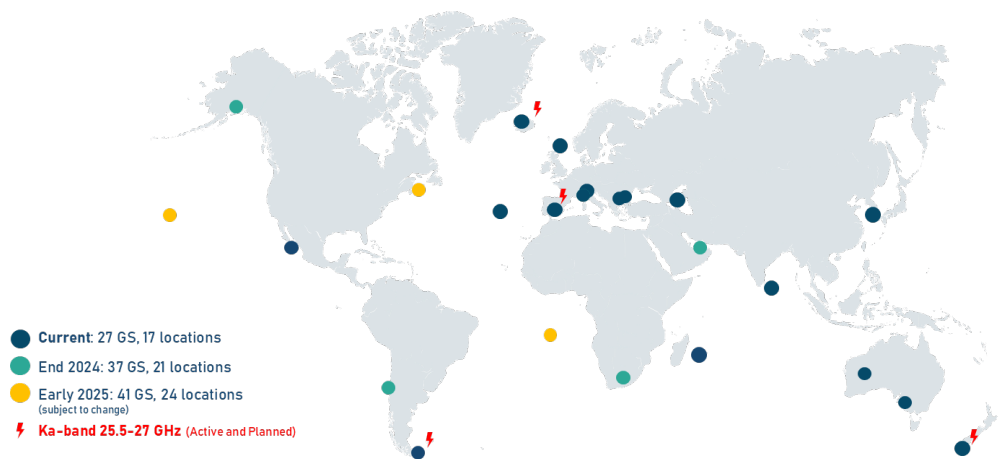

Figure 11.9: The Leaf Line network, September 2024. Credit: Leaf Space.

## Laser Light

Laser Light Communications operates a Global Network platform, delivering a first-of-a-kind 21st century data service that will transform the way high volume communications traffic is carried. Using a hybrid infrastructure spanning terrestrial, subsea, and space domains; an end-to-end software defined architecture offering all-optical: up to 400 Gbps connectivity and provisioning within minutes (see <https://www.laserlightcomms.com/>).

### Network On Demand

- Pay-as-you-go: only pay for the duration you use the service with no upfront or fixed costs
- Cost Effective: automation and end-to-end control yields significant operating cost savings



- Secure: highly targeted, dynamic, laser links are extremely difficult to intercept and can be encrypted
- High Capacity/ Performance: data delivery at up to 400 Gbps in the most direct route from origination to destination, automatically bypassing points of congestion

### Data Transport as a Service

- Pay-as-you-go: only pay for volume you use when you use it with no upfront or fixed costs
- Cost Effective: automation and end-to-end control yield significant operating costs savings
- Secure: highly targeted, dynamic, laser links are extremely difficult to intercept and can be encrypted
- High Capacity/Performance: data delivery at optical speeds -- up to 400 Gbps directly from the point of origination to the point of destination, automatically bypassing points of congestion along the way

### Atlas Global Network

ATLAS Space Operations, Inc. provides satellite RF communication services to the government and commercial sectors through geographical dispersion and cloud services, offering GSaaS on a global network of 34 ground stations and 51 antennas (<https://atlasspace.com/>).

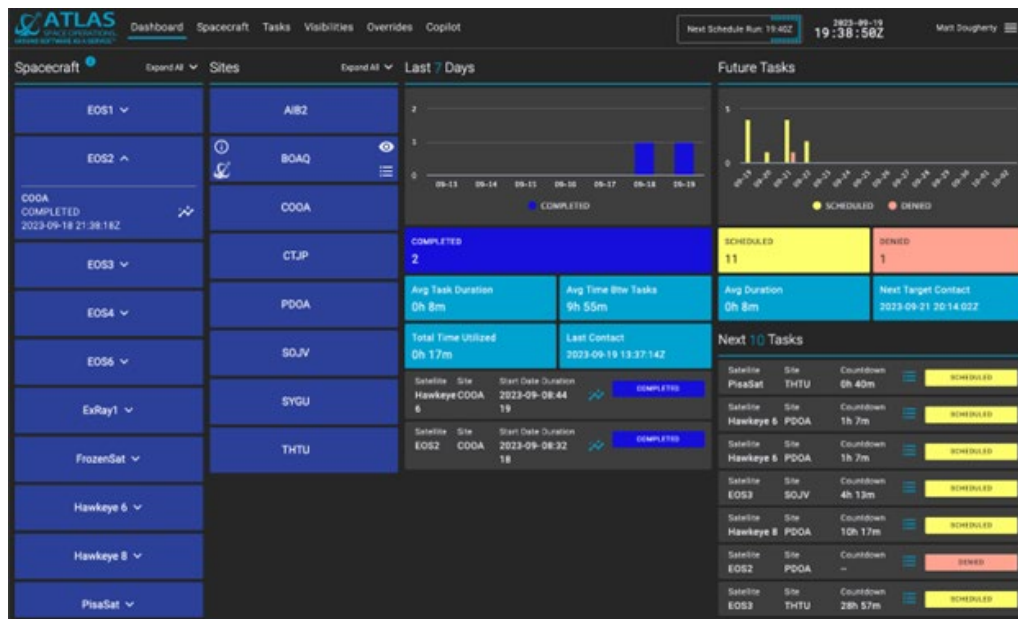

Figure 11.10. The Freedom™ Software Platform is a simple and scalable ground network management system. Credit: ATLAS Space.

All ATLAS ground stations are built upon the Freedom™ Software Platform (Figure 11.10) within a cloud-based distributed operations center which facilitates dynamic demand and scalable growth. Through geographical dispersion of its ground stations and cloud services, ATLAS provides a resilient capability that delivers dependable low latency data. ATLAS bases its mission success model on its global network of operational and traditional RF parabolic ground stations that are integrated with network management and scheduling software. These platforms work together as a mission architecture to meet customer requirements for routine satellite-to-ground communications.





ATLAS' Global Antenna Network is fully integrated with the Freedom Software, providing users with a robust, low latency, and secure communications solution, including: automated network operations, set-and-forget scheduling, mixed modem capability, real-time metrics, and single secure VPN access. Once integrated into the ATLAS Network, a single secure VPN enables access and load balancing of network resources. Freedom Core Services advance operations beyond legacy constructs and enable users the freedom and flexibility to reliably schedule satellite passes with minimal human interaction via machine-to-machine capabilities. Entire data processing and forwarding workflows can be automated within the cloud to ensure spacecraft data is ready for use as soon as it arrives at the Mission Operations Center.

ATLAS supports deploying clusters and serverless instances onto AWS. ATLAS hardware parameters are highlighted below (ATLAS Enterprise Sites and Digital Partner Sites). In addition to S-band and X-band capabilities, ATLAS can provide VHF, UHF services in Japan and Guam. The existing and planned ATLAS antenna systems support RF connectivity for LEO, MEO, GEO, and L1 orbits. ATLAS is actively pursuing technology development for deep space capabilities. ATLAS' global federated network is also displayed below. A summary of government and commercial ground stations and antennas in Table 11-8 and shown in Figure 11.11 is ATLAS' Global Federated Network of ground stations.

Freedom Space Technologies, Inc. dba Freedom Space was established in 2023 as a non-traditional small business and wholly-owned subsidiary of ATLAS Space Operations. Freedom Space, headquartered in Colorado Springs, CO, is purpose built to address and support the Department of Defense (DoD) and Intelligence Community (IC) mission requirements.



Figure 11.11: ATLAS Space Operations ground network map September 2024. Credit: ATLAS Space Operations.

Location	Lat	Long	Antenna Size (m)	Rx Freq (MHz)	G/T Long (dB/K)	Tx Freq (MHz)	EIRP (dBW)	Polarization
Utqiagvik (Barrow), AK, USA	71.27	-156.81	3.7	S: 2200-2300 X: 7900-8400	12.8 25.4	S: 2025-2120	60.0	R/LHCP
Dundee, Scotland	56.40	-3.18	3.7	S: 2200-2400	13.6 26.5	S: 2025-	48.0	R/LHCP



Location	Lat	Long	Antenna Size (m)	Rx Freq (MHz)	G/T Long (dB/K)	Tx Freq (MHz)	EIRP (dBW)	Polarization
				R/LHCP X: 7800-8400		2120		
Chitose, Japan	42.77	141.62	3.4	S: 2200-2300 X: 7900-8500	11.5 26.4	S: 2025-2120	52.0	R/LHCP
Mojave, CA, USA	35.05	-118.15	3.0	S: 2200-2300 X: 7900-8500	11.3 25.9	S: 2025-2110	54.4	R/LHCP
Dubai, United Arab Emirates	24.94	55.35	3.7	S: 2200-2300 X: 7900-8400	12.8 25.4	S: 2025-2120	50.0	R/LHCP
Paumalu, Hawaii, USA	21.67	-158.03	7.3	S: 2200-2300 X: 7900-8500	20.7 31.0	S: 2025-2120	65.0	R/LHCP
Harmon, Guam	13.51	144.82	3.7	S: 2200-2300 X: 7900-8400	13.6 25.1	S: 2025-2110	52.4	R/LHCP
Sunyani, Ghana	7.34	-2.34	3.0	S: 2200-2300	12.4	S: 2025-2110	50.1	RHCP
Mwulire, Rwanda	-1.96	30.39	9.3	S: 2200-2300 X: 7900-8500	21.5 36.0	S: 2025-2120	60.0	R/LHCP
Tahiti, French Polynesia	-17.63	-149.60	3.7	S: 2200-2300 X: 7900-8400	13.9 27.4	S: 2025-2110	47.5	R/LHCP
Awarua, New Zealand	-46.52	168.38	3.7	S: 2200-2300 X: 8025-8500	13.7 27.0	S: 2025-2120	49.0	R/LHCP
Sodankylä, Finland*	67.36	26.63	7.3	S: 2200-2300 X: 7900-8500	19.8 32.1	S: 2025-2110	54.8	R/LHCP
Öjebyn, Sweden	65.33	21.42	7.3	S: 2200-2290 X: 8025-8400 Ka: 25500-27000	18.0 32.0 35.7	S: 2025-2110	55.2	R/LHCP
North Pole, Alaska, USA	64.79	-147.53	7.3	S: 2200-2300 X: 8000-	19.0 32.0 35.7	S: 2025-2120	53.0	R/LHCP



Location	Lat	Long	Antenna Size (m)	Rx Freq (MHz)	G/T Long (dB/K)	Tx Freq (MHz)	EIRP (dBW)	Polarization
				8500 Ka: 25500-27000				
Stockholm, Sweden*	-	-	5.4	S: 2200-2300 X: 7750-8400	16.0 30.5	S: 2025-2120	50.0	R/LHCP
Dublin, Ireland*	-	-	5.4	S: 2200-2300 X: 7750-8400	16.0 30.5	S: 2025-2120	50.0	R/LHCP
Guildford, United Kingdom	51.24	-0.61	5.4	S: 2200-2290 X: 8025-8400	17.0 30.0	S: 2025-2110	53.2	R/LHCP
Portland, Oregon, USA*	-	-	5.4	S: 2200-2300 X: 7750-8400	16.0 30.5	S: 2025-2120	50.0	R/LHCP
Obihiro, Japan	42.59	143.45	7.3	S: 2200-2290 X: 8025-8400 Ka: 25500-27000	17.9 31.5 35.0	S: 2025-2110	55.2	R/LHCP
Columbus, Ohio, USA*	-	-	5.4	S: 2200-2300 X: 7750-8400	16.0 30.5	S: 2025-2120	50.0	R/LHCP
Seoul, South Korea*	-	-	5.4	S: 2200-2300 X: 7750-8400	16.0 30.5	S: 2025-2120	50.0	R/LHCP
Pendergrass, Georgia, USA	34.17	-83.67	5.4	S: 2200-2290 X: 8025-8400	17.0 30.0	S: 2025-2110	53.2	R/LHCP
Deadhorse, Alaska, USA*	-	-	5.4	S: 2200-2300 X: 7750-8400	16.0 30.5	S: 2025-2120	50.0	R/LHCP
Zallaq, Bahrain*	-	-	5.4	S: 2200-2300 X: 7750-8400	16.0 30.5	S: 2025-2120	50.0	R/LHCP
Kapolei, Hawaii, USA*	-	-	5.4	S: 2200-2300 X: 7750-8400	16.0 30.5	S: 2025-2120	50.0	R/LHCP
Accra, Ghana	5.74	-0.30	7.3	S: 2200-2290	18.0 32.0	S: 2025-	65.0	R/LHCP



Location	Lat	Long	Antenna Size (m)	Rx Freq (MHz)	G/T Long (dB/K)	Tx Freq (MHz)	EIRP (dBW)	Polarization
				X: 8025-8400 Ka: 25500-27000	35.7	2110		
Singapore*	-	-	5.4	S: 2200-2300 X: 7750-8400	16.0 30.5	S: 2025-2120	50.0	R/LHCP
Alice Springs, Australia*	-23.75	133.88	7.3	S: 2200-2290 X: 8025-8400 Ka: 25500-27000	18.0 32.0 35.7	S: 2025-2110	65.0	R/LHCP
Pretoria, South Africa	-25.88	27.70	7.3	S: 2200-2290 X: 8025-8400 Ka: 25500-27000	18.0 32.0 35.7	S: 2025-2110	55.2	R/LHCP
Mingenew, Australia*	-29.01	115.34	5.0	S: 2200-2300 X: 8025-8500	14.0 29.5	S: 2025-2120	55.0	R/LHCP
Cordoba, Argentina	-31.52	-64.46	5.4	S: 2200-2290 X: 8025-8400	17.0 30.0	S: 2025-2110	53.2	R/LHCP
Cape Town, South Africa*	-	-	5.4	S: 2200-2300 X: 7750-8400	16.0 30.5	S: 2025-2120	50.0	R/LHCP
Dubbo, Australia*	-	-	5.4	S: 2200-2300 X: 7750-8400	16.0 30.5	S: 2025-2120	50.0	R/LHCP
Punta Arenas, Chile*	-	-	5.4	S: 2200-2300 X: 7750-8400	16.0 30.5	S: 2025-2120	50.0	R/LHCP
Ushuaia, Argentina	-54.51	-67.11	7.3	S: 2200-2290 X: 8025-8400 Ka: 25500-27000	17.9 32.0 33.0	S: 2025-2110	56.0	R/LHCP

### 11.4.3 Space Relay Network - NASA

Unlike a traditional ground network that goes direct from a “client” satellite to a ground station on the ground, space relay networks consist of communication satellites that relay data from the “client” satellite down to a ground station. While some no longer consider it state-of-the-art, NASA’s Tracking and Data Relay Satellite System (TDRSS), shown in Figure 11.12, is one of the most well-known space relay networks. TDRSS relays data from the International Space Station (ISS) and the Hubble Space Telescope to NASA ground stations around the world.



Figure 11.12: NASA’s Tracking and Data Relay Satellite System. Credit: NASA.

Space relay networks can be beneficial for small satellites in low-Earth orbit because those SmallSats are only in view of a ground station for a portion of their orbit. However, depending on the orbit of the relay satellites, a low-Earth orbit SmallSat could be in view of a relay satellite for most of its orbit. This makes a relay network beneficial for a SmallSat, especially right after SmallSat deployment when a ground station is still trying to locate the satellite. The space relay can transmit satellite telemetry, tracking, and control data to the ground, enabling faster satellite identification. This proves to be even more valuable when the satellite is deployed with several others for a given rideshare opportunity. This data can also contain satellite health information to give mission teams either peace of mind while awaiting acquisition by the ground station, or information for troubleshooting prior to the commissioning phase. Another benefit is the ability to obtain real-time event notifications without the need for prior scheduling. Scientists are interested in using this technology to alert the science community when certain phenomenon are observed. Space relay networks often require special hardware or software that must be added to a satellite before launch. In general, a satellite operator will purchase a modem compatible with the relay network and fly it on their satellite to access the network. It is common for the network providers to license their proprietary chipset to developers who build the modem hardware and serve as a service broker. Because of this added hardware component, the decision to leverage a space relay network must be made before the satellite has been launched.

#### 11.4.4 Low Latency, Low Rate (Short Burst) Space Relay Providers

Space relay solutions are less common than traditional direct-to-Earth solutions, but there are a few options that exist for small satellites (see Table 11-9). To access the space relay, a satellite operator purchases a modem from the relay manufacturer and flies that on their satellite to access



the relay services. In general, space relays are ideal for obtaining satellite TT&C data (health and safety of the vehicle) rather than for large data downlinks.

<b>Product</b>	<b>Manufacturer</b>	<b>TRL</b>	<b>Specifications</b>
Iridium Global Network	Iridium	9	LEO relay requiring 9600 series transceivers onboard the satellite
Fast Pixel Network	Analytical Space	6	Establish a data transport network in LEO

**The Iridium network** is one example satellite customers can rely on for delivering low latency messages. Iridium uses a combination of Frequency Division Multiple Access (FDMA) and Time-Division Multiple Access (TDMA) for its communication waveforms. L-band (1616 – 1626.5 Mhz) is used for uplink and downlink between the user spacecraft and the Iridium spacecraft. Inter-satellite communication links between Iridium satellites is accomplished through Ka-band (23.18 – 23.28 GHz). Operators install an Iridium transceiver (9600 series) onboard their spacecraft to communicate with the Iridium network. Messages are relayed through Iridium’s Short Burst Data Service, which is hosted on Iridium’s cloud platform for easy user operation. For each transceiver unit, a data plan must be chosen and purchased, much like cellular phone data plans, and the plan details are linked to the unit’s ID, which is referred to as International Mobile Equipment Identity (IMEI). The special feature of this system is that it has as an option for “IMEI-to-IMEI” transmission. When an Iridium IMEI is activated, five output destinations may be specified. Most vendors allow for a combination of emails addresses, fixed IP address, or another device with an IMEI ID (6).

Iridium has announced the commercial availability of its Certus 100 ‘midband’ service providing 88 kbps connectivity via small antennas and battery-powered devices, for basic data communications and IoT applications (10).

**Analytical Space** is another company to watch for future services. Their recent contract puts a LEO relay in space to aggregate data from GEO satellites. Through Fast Pixel Network, Analytical Space Inc. plans to establish a data transport network in low-Earth orbit to ingest data from geospatial intelligence satellites, send the data from node to node via high speed optical intersatellite links, and deliver the data to military, intelligence and commercial customers (11). High speed MEO and GEO commercial relays are not presently operating, but several are planned. These are listed under the State-of-the-Art Ground Data and Supporting Systems section (11.9).

## **11.5 Ground Stations Components**

The hardware for ground stations consists of the tracking antenna, its feed, and the modem that converts the RF waveform into digital packets and vice versa.

### **11.5.1 Ground Station Operation**

A DTE ground station is comprised of a system of hardware and software working together to convert the RF signal from a satellite signal into digital data. The first key element of the system is the antenna. It is chosen based on the frequency and gain required to talk with a satellite. NASA uses parabolic reflector antennas for RF ground satellite communications, while some universities use dish or Yagi antennas.

The dish antenna uses a parabolic reflector to collect signals from the spacecraft and focus them onto a feed antenna. The feed antenna is typically a horn antenna with a circular aperture. The size of a dish is at least several wavelengths in diameter at the frequency of operation and can be increased for higher gains. The distance between the feed antenna and parabolic reflector can



also be several wavelengths. For example, a Ka-band 34 m deep space antenna with a feed distance of 15 m would be approximately 3,000 wavelengths for the dish diameter and 1,500 wavelengths for the feed distance relative to a 1 cm Ka-band wavelength. The gain of a dish reflector (Figure 11.13) is frequency-dependent and it is directly related to the square of its diameter. Dish antennas are available in sizes from 1 meter to 70 meters in diameter.

The antenna collects RF waves and the antenna feed converts the electromagnetic waves into conducted RF electrical signals. The feed consists of a resonant pickup that is tuned to the transmit or receive frequency, a low gain low-noise amplifier, a sharp filter, and a second LNA with more gain than the first amplifier. These elements condition the signal. The signal then traverses through a coaxial cable to a nearby location where a radio demodulates the RF signal into digital data. In the uplink direction, the radio modulates the data bits onto an RF carrier which is amplified to 10 or more watts. The amplified RF resonates in the antenna feed, and the antenna amplifies the electromagnetic waves and focuses them towards the satellite.



*Figure 11.13: Ground Antenna in Fairbanks, Alaska.  
Credit: NASA/ Clare Skelly.*

It is desirable to have significant antenna gain, but as the gain increases, the beamwidth of the antenna decreases. There is a practical compromise where the beamwidth is so small that tracking is difficult and when the antenna gets so large that it is difficult to procure or manage. A typical antenna pattern is shown in Figure 11.14. There is a center lobe where most of the transmitted energy is contained. The remaining energy is stored in the sidelobes on either side of the main lobe. The diminished side lobes are intentional so that ground noise from other emitters on Earth are not collected when receiving and so that interference to terrestrial systems is not created when transmitting. The blue arrows in the Figure indicate the full-width-half-max gain point at about  $\pm 6^\circ$ , which should result in an antenna pointing error of less than  $6^\circ$  and the full-width-half-max gain of 16 dBi to be used in a link budget. If more gain is needed, then the antenna will increase in size and the beamwidth will correspondingly decrease.

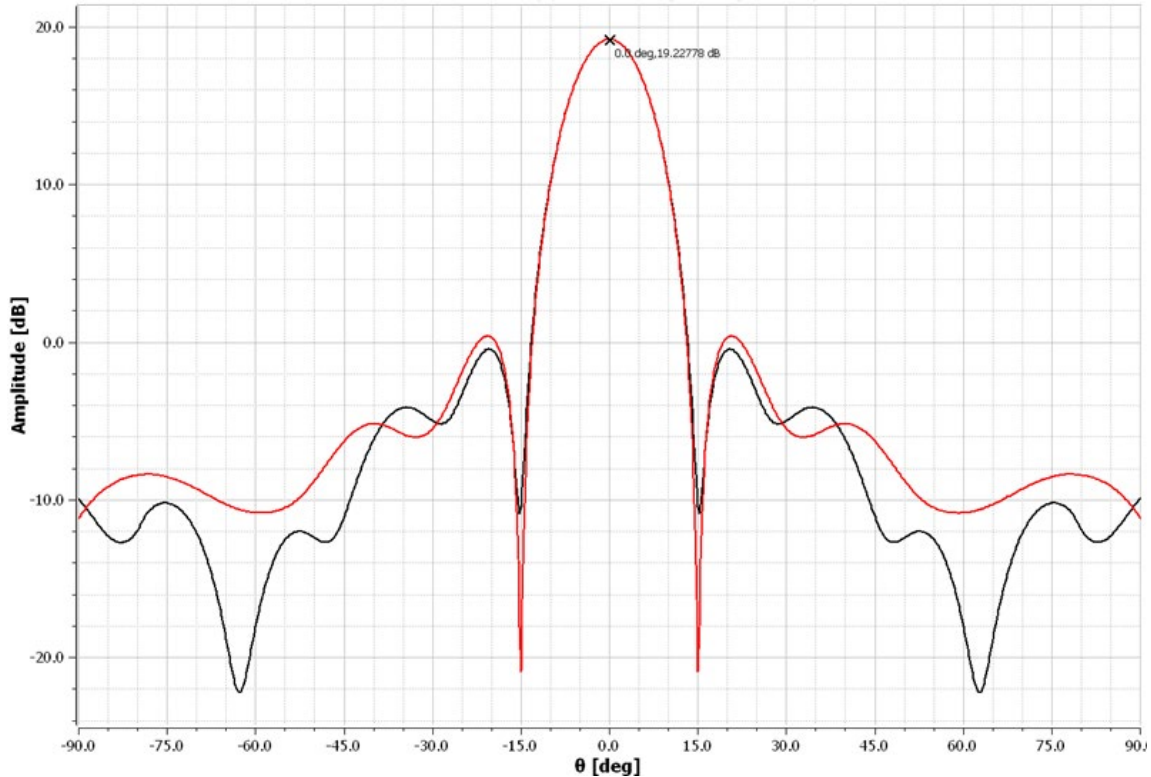

Figure 11.14: Antenna pattern from a 1.8-meter diameter parabolic dish operating at 915 Mhz with a high gain center lobe and diminished side lobes. Credit: NASA.

Directional antennas point towards the satellite as it moves over the ground station. Pointing adjustments are necessary in both the vertical (elevation) and horizontal (azimuth) directions. These movements are accomplished using motors and gears. Tracking software is used to predict the satellite's future location. The satellite position and time are processed through additional software that converts this information into commands for the motor controller. Time is an important factor and GPS time is used by the computer generating the satellite position estimate. A dedicated GPS receiver is connected to the computer for that purpose.

The cost of a DTE ground station is directly correlated with the size of the aperture, which drives the ground station foundation, pedestal, motors, and gears. The Yagi is less expensive. It sustains low wind loads and therefore can use a smaller foundation for support. In contrast, the dish antenna reflector sustains comparatively high wind loading and therefore needs a stronger concrete foundation and larger motors and gear box elements than the Yagi antenna.

### 11.5.2 Component Hardware for Ground Systems (GS)

This section lists examples of GS components and some supporting equipment. Table 11-10 lists example products in each category. The antenna feed consists of the RF pickup, LNA and mechanical filters located directly on the antenna. A radome is an RF transparent enclosure that protects the antenna from weather.

Table 11-10: Ground System Components		
Product	Manufacturer	Type of Product
Tracking Antenna	Viasat, Safran	Antennas for small satellites in and S, X and Ka-band frequencies
Antenna Feed	See End-to-End Hardware Section	RF pickup, mechanical filters, LNA



	11.7.2	
Radio, Software Defined	NI Ettus Research	USRP X410, up to 7.2 GHz with RFSoC advanced FPGA and meeting wide bandwidth requirements. USRP X310: DC-6 GHz with up to 160 MHz of baseband bandwidth, multiple high-speed interfaces
Data Receiver	Safran Data Systems	Cortex CRT (low data rate) and HDR (high data rate (previously by Zodiac))
Modem, for TT&C and Payload Reception	Safran Data Systems	Satcore, plug-and-play modem for TT&C and Payload Reception
Digital Processing	Kratos	SpectralNet: Digital IF product that converts analog signals at RF frequencies up to S-band into digital IF packets.
Radome	Infinite Technologies	Antenna radomes
Ground Station Dongle	GAUSS	A USB low-power board to simulate ground station in laboratory conditions. The USB dongle integrates both a low-power UHF transceiver and a TNC, thus miniaturizing common ground station rack systems
Integrated Testing Systems (EGSE) & Ground Station TT&C Modems	Celestia Satellite Test & Simulation	Hardware and software elements all operating within a single reference platform and environment

### Cortex HDR

Several NSN, SSC and NOAA stations use the Cortex HDR High Data Rate Receiver, which performs demodulation, decoding and frame synchronization on the (X-band) data stream. Each virtual channel in the AOS frame that is received by the station X-band receiving system will be written into separate files. Files are separated into small one-minute file sizes for a single VCID that allow for faster turn-around time on the data and smaller transmission cycles in case of transfer problems. File-based data is stored in a buffer (e.g., for 7 days) used for retransmissions and failure recovery when necessary. At the end of a pass, ground stations such as the NSN ones, perform an automatic secure file transfer protocol (SFTP)/secure copy protocol (SCP) push to the customer. If the customer wants to “replay” a dataset, they may use the self-service /SFTP/SCP interface on the system to pull their data to their site. Alternatively, the customer may choose to manually retrieve files and not select automatic file transfer (12).

### USRP X310 and X410 Open-Source Software Defined Radio for SatCom Applications

The NI Ettus Research brand includes the Universal Software Radio Peripheral (USRP™) family of products. The USRP is one of the most popular open platforms for small satellite communications with options from high-performance to low-cost to highly deployable. One of the most popular hardware units for satellite communication applications is the USRP X310 with the UBX RF daughterboard. The USRP X310 is a high-performance software defined radio with the ability to transmit and receive modulated signals. With up to 160 MHz of instantaneous bandwidth and a frequency tuning range up to 6 GHz, the X310 with UBX has the raw hardware performance to cover many ground station satellite communication needs. The USRP family supports a wide range of software tool chains from LabVIEW to GNU Radio, with many existing IP modules for modulation and demodulation. The USRP X310 is intended for lab environments, however, it can



be built in rugged weatherproof configurations. Many small satellite researchers are using the USRP as their ground station equipment for its adaptability with open-source software and its embedded FPGA pre-processing capability. The USRP X310 offers 2 channels, 10 GIGE and PCIE bus, whereas the NI Ettus USRP X410 is equipped with two dual 100 GbE interfaces capable of moving much more data (13).

### **Kratos OpenSpace® SpectralNet®**

OpenSpace SpectralNet eliminates the distance constraints of RF transport by digitizing RF signals into standard VITA-49 or DIFI IP packets for transport over IP networks in a way that preserves both frequency and timing characteristics, and then uniquely restores the RF signals at their destination. By eliminating the distance constraints between antennas and signal processing equipment, this technology enables operators to deploy new ground architectures with numerous advantages, such as the ability to mitigate the effects of rain fade for Ku/Ka satellites, reduce costs by centralizing operations, simplify disaster recovery and system maintenance, optimize antenna placement, and develop a migration path toward virtual ground systems. SpectralNet does all of this while protecting the operator's current investment in existing equipment (14). In addition to removing distance constraints, digitizing RF signals into DIFI packets also provides the on-ramp to virtualizing network functions such as modems, receivers, etc.

### **Integrated Testing Systems & Ground Station TT&C Modems**

Celestia Satellite Test & Simulation BV (C-STs) provides ground-based solutions in the domains of satellite simulation, testing, communication, and data processing. Established in 1985, Satellite Services B.V. (SSBV) was acquired by Celestia Technologies Group in 2016 and re-branded to Celestia Satellite Test & Simulation B.V. to continue as a competence center for Electrical Ground Support Equipment (EGSE) and TT&C solutions. Celestia STS has more than 30 years of experience in the space industry. More than 300 EGSEs and TT&C modems were delivered to space agencies, large system integrators, and specialized flight-equipment manufacturers around the world.

On-board computers, mass memory units, and transponders are tested every day with C-STs equipment. Celestia EGSE solutions have been used in more than 80% of all European Space Agency (ESA) missions. Celestia STS testing equipment is available in standard functionality or configured to meet specific customer needs. System options include:

- Multi-Purpose Interface Platform
  - Test and simulation of spacecraft electrical interfaces
  - Discrete TM/TC, power and digital data interfaces
  - RS422/RS485/LVDS, SpaceWire, SERDES and parallel/serial LVDS
  - Up to two different bus voltage inputs for LCL and heater interfaces
  - Two gigabit ethernet ports for control/monitoring and data via TCP/IP (RJ45)
  - FMEA reports available for all interface modules
- Telemetry and Telecommand Processing System
  - TM acquisition and simulation
  - TC generation and acquisition
  - Bit error rate tester
  - TC authentication support
  - TM/TC deciphering (API/DLL/LAN)



- Includes control and monitoring software for data processing and visualization
- Wizardlink High-Rate Interface System
  - Up to 4 Wizardlink bi-directional channels operating in parallel (2Gbps per channel)
  - 10Gbit LAN for data streaming via TCP/IP (using SFP+)
  - LVDS Flow Control TIA/EIA-644-A compliant
  - Includes software for high speed ingest, data archiving and export
  - Optional software for Level Zero data processing
- LVDS High-Rate Interface System
  - Up to 4 parallel LVDS inputs and outputs
  - 8-bit parallel up to 1Gbps per channel
  - 10Gbit LAN for data streaming via TCP/IP (using SFP+)
  - TIA/EIA-644-A compliant LVDS interfaces
  - Teaming of 2 LVDS input and output channels to 16-bits
  - 8-bit Parallel >1Gbps per channel, 16-bit parallel >2Gbps per channel
  - Includes software for high speed ingest, data archiving and export
  - Optional software for Level Zero data processing
- TT&C Integrated Modem and Baseband Unit
  - Single or dual channel modulation and demodulation (70MHz I/F)
  - Ranging measurement
  - Doppler simulation
  - Bit error rate tester
  - Baseband TM and TC processing (optional)
- MIL-STD-1553 Interface System
  - Up to 4 independent, dual redundant MIL-STD-1553 channels
  - Bus controller, remote terminal and bus monitoring functionality
  - External time/reference inputs, such as 10MHz, PPS and IRIG
  - Fully compliant to MIL-STD-1553B Notice II/IV
  - Specific protocol adaptations available
- CANopen Interface System
  - Compliant with CAN specification 2.0A (11-bit ID) & 2.0B (29-bit ID)
  - Master, slave node and bus monitoring functionality
  - Transceivers support 1Mbps high-speed CAN bit rate (ISO-11898-2)
  - Simultaneous real-time and non-intrusive monitoring of multiple CAN channels
- Level Zero Processor Software for High-Speed Data Processing
  - Data directly from the local disk drive or shared network drive
  - Processing of TM data from bitstream to frame and packet level
  - Configurable frame and packet checking rules
  - Configurable frame and packet output data storage and sorting





- Live frame and/or packet distribution via LAN
- Real-time statistical analysis, error checking, and reporting
- CFDP data processing support
- Optical Modem
  - Standard compatibility: SDA, CCSDS O3K RS Branch, custom
  - Multiple tunable optical Tx outputs with programmable skew (optical C-band)
  - Powerful receiver for very low optical input powers
  - FC/APC inputs and output mating ports
  - 10Gbit LAN for data ingress/egress

Efforts are on-going to improve product capability with a focus on modular, flexible, scalable multichannel systems that take advantage of the latest technologies (15).

### Infinite Technologies Radomes

A well-designed radome serves as a protective cover for an antenna while minimizing any adverse effects on its electrical performance. Figure 11.15 illustrates an example of a radome supplied by Infinite Technologies. Radomes create a controlled environment for the antenna system, shielding sensitive equipment from environmental stresses such as wind, snow, ice, and salt spray. By protecting the antenna from these elements, a radome can extend its operational life and reduce overall maintenance costs.



*Figure 11.15: Infinite Technologies small radome. Credit: Infinite Technologies.*

Incorporating a radome early in the system design phase is crucial. Doing so allows for the use of lighter and more cost-effective components, such as drive motors and foundations, since the radome eliminates wind loads on the antenna. Additionally, the controlled environment within the radome increases system availability, enabling the antenna to operate efficiently under harsh environmental conditions with minimal signal degradation. Maintenance personnel also benefit from the radome, as it offers protection from the weather during antenna maintenance activities.

For a radome to be truly effective, it must be tailored to the specific requirements of the system it





protects. A carefully selected and well-designed radome can enhance overall system performance and reliability by:

- Enabling operation in severe weather conditions, shielding the antenna from wind, rain, snow, hail, sand, salt spray, insects, animals, UV damage, windblown debris, and extreme temperature fluctuations.
- Creating a controlled environment that minimizes downtime, prolongs component and system life, and supports more economical choices in antenna pedestals, foundations, and drive systems.
- Providing security and protection for the antenna system from observation, vandalism, and other threats.

### 11.5.3 Ground Software

Ground station visualizes and calculates the satellite location in orbit and controlling the tracking antenna. Command and control software manages command scripts to be sent to the satellite and can display and analyze telemetry. Many software options are open source and free. Other software may be purchased from companies with a long history in ground segment solutions who had previously provided hardware products to do these tasks (Table 11-11).

Product	Manufacturer	TRL	Type of Product
softFEP	AMERGINT	9	Emulation ground systems software
OpenSpace quantumFEP	Kratos	9	Software that performs data formatting and interface conversion for commands and telemetry, with full support for NSA Type 1 and AES encryption/decryption devices
Gpredict	Alexandru Csete	9	Open-source software that tracks satellites and provides orbit prediction in real-time. Radio and antenna rotator control for autonomous tracking
GNU Radio	GNU Project	9	Free software development toolkit that provides signal processing blocks to implement software-defined radios and signal processing systems
HWCNTRL	DeWitt & Associates	9	Ground station control program with an automation software package

#### **AMERGINT softFEP**

AMERGINT softFEP applications are deployed virtually on cloud architectures or hosted on dedicated servers. The applications perform control center data formatting and interface conversion for commands and telemetry, with full support for NSA Type 1 and AES encryption/decryption devices. SoftFEP applications are built on a proven library of more than 1,000 software devices. This allows each softFEP application to be tailored to the requirements specific to the ground system. Processing chains configured via Python scripts move satellite downlink data from Earth receipt for processing and uplink data to the radiating site. Deploying softFEP on multiple virtual machines (VMs) or within the cloud is inherent in the product architecture. Virtualized softFEP deployments support a wide range of ground system architectures while taking advantage of cloud-computing benefits. When applications are deployed in VMs, they can be hosted locally or run remotely in a cloud and interoperate across network connections. Customers have deployed their softFEP applications as independent network gateways, black front-end processors, red front-end processors, and data recorders, flowing data between the VMs as a satellite contact is processed (17).

## Kratos quantumFEP

OpenSpace quantumFEP (qFEP) is a virtual front-end processor for Telemetry, Tracking, and Command (TT&C). The system has been specifically designed to match the requirements, schedules, and budgets of quick turn programs. qFEP connects C2 systems to RF signal processing equipment, handling command and telemetry stream formatting, encryption/decryption devices, CCSDS processing, and network interfaces to either quantumRadio (qRADIO) or third-party ground antenna networks. Using generic compute servers, virtual machine environments, bare metal installations, or orchestration through Kratos OpenSpace Platform are supported operational types, and qFEP's small memory footprint allows for more efficient use of system resources. In addition, the product achieves independence by eliminating custom drivers, firmware, and hardware cards. Figure 11.16 provides an illustration of the qFEP system architecture (18).

Key features of quantumFEP are:

- Pure software implementation for signal processing functions
- Support for CCSDS TC, TM and AOS frame protocols, as well as Cadet, Ax.25 and Reed Solomon Encoding
- Suitable for all types of satellite programs
- Compatibility tested with widely used ground modems
- Built-in test functions reduce integration and test (I&T) effort and costs
- Configurable as mission requirements change or as new missions come online
- Commercial AES encryption/decryption standard feature with built in AES Key Manager
- Standard TCP/IP, GEMS, REST and VITA-49 interfaces make integration seamless
- Access and control from anywhere through the web. No client software to install or maintain

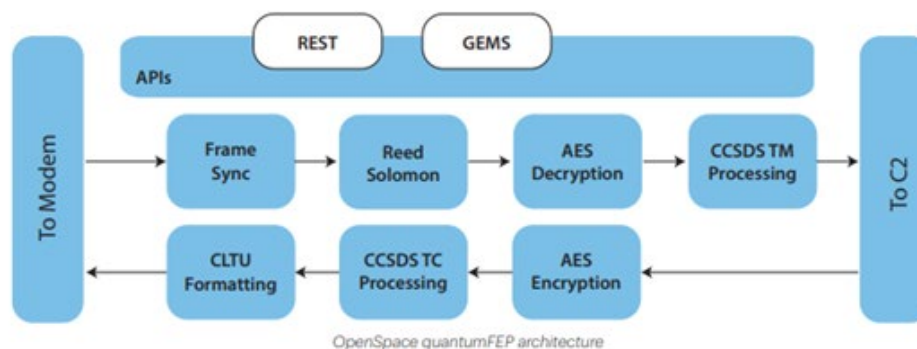

Figure 11.16: Kratos qFEP system architecture. Credit: Kratos.

## Gpredict

Gpredict is a real-time satellite tracking and orbit prediction application. It can track a large number of satellites and display their position and other data in lists, tables, maps, and polar plots (radar view) as shown in Figure 11.17. It can also predict the time of future passes for a satellite and provide detailed information about each pass. Gpredict is different from other satellite tracking programs in that it allows the satellites to be grouped into visualization modules. Each of these modules can be configured independently from others, allowing unlimited



flexibility in the look and feel of the modules. It will also allow satellite tracking relative to different observer locations at the same time (19).

The following are key features of the software:

- Fast and accurate real-time satellite tracking using the NORAD SGP4/SDP4 algorithms
- No software limit on the number of satellites or ground stations
- Appealing visual presentation of the satellite data using maps, tables and polar plots (radar views)
- Allows satellites to be grouped into modules, each module having its own visual layout, and being customizable on its own. Of course, several modules can be used at the same time
- Radio and antenna rotator control for autonomous tracking
- Efficient and detailed predictions of future satellite passes. Prediction parameters and conditions can be fine-tuned by the user to allow both general and very specialized predictions
- Context sensitive pop-up menus allow future passes to be quickly predicted by clicking on any satellite

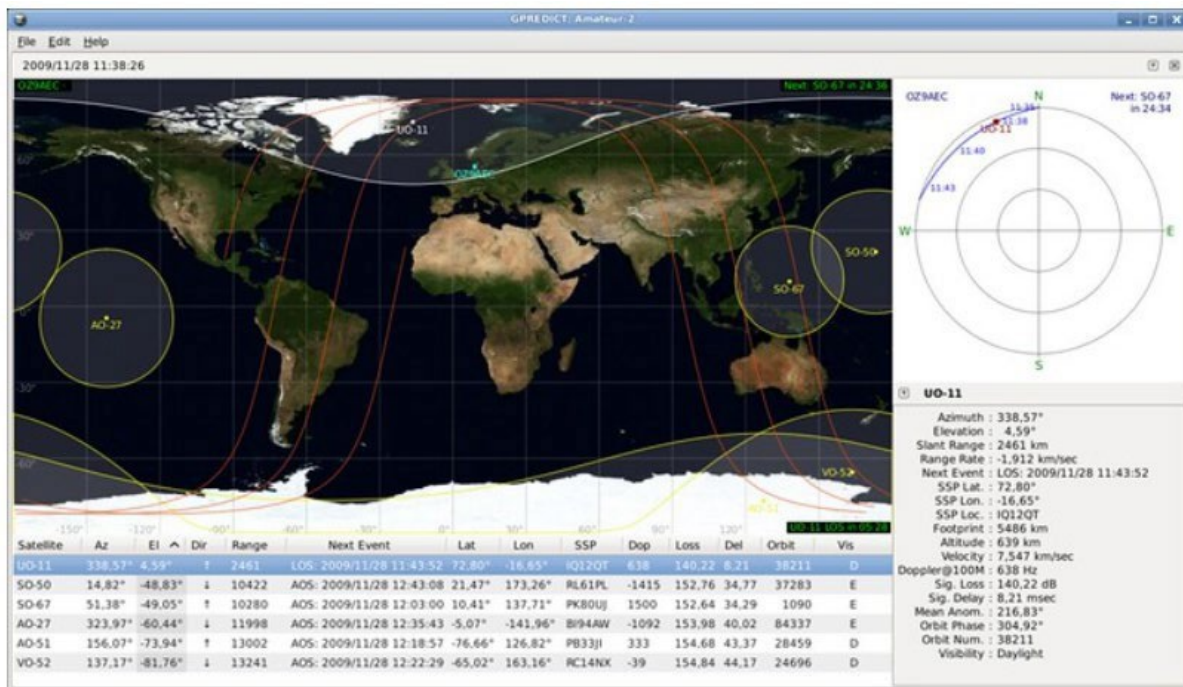

Figure 11.17: Gpredict graphical display with multiple satellites. Credit: Gpredict.

- Exhaustive configuration options allowing advanced users to customize both the functionality and look & feel of the program
- Automatic updates of the Keplerian Elements from the web via HTTP, FTP, or from local files
- With a robust design and multi-platform implementation, Gpredict can be integrated into modern computer desktop environments, including Linux, BSD, Windows, and



### Mac OS X

- As free software licensed under the terms and conditions of the GNU General Public License, it can be freely used, learned from, modified, and re-distributed

### GNU Radio

GNU Radio is a free & open-source software development toolkit for developing radio systems in software as opposed to completely in hardware. It can be used with readily available low-cost external RF hardware and runs on most modern computers to create software-defined radios. It can also be used without hardware in a simulation-like environment.

GNU Radio performs all the signal processing and can be used to write applications to receive data out of digital streams or to push data into digital streams, which are then transmitted using hardware. GNU Radio has filters, channel codes, synchronization elements, equalizers, demodulators, vocoders, decoders, and many other elements (referred to as blocks) typically found in radio systems. More importantly, it includes a method of connecting these blocks and then manages how data is passed from one block to another. Blocks can be implemented in C++ or Python.

Since GNU Radio is software, it can only handle digital data. It operates with digitally sampled waveforms that can correspond to an RF signal with digital or analog modulation. Usually, complex baseband samples are the input data type for receivers and the output data type for transmitters. Analog hardware is then used to shift the signal to the desired center frequency. That requirement aside, any data type can be passed from one block to another—be it bits, bytes, vectors, bursts, or more complex data types. GNU Radio supports heterogeneous computing, where some of the blocks run on an FPGA or GPU. These acceleration techniques are particularly important for processing large bandwidths or data rates, and also in embedded platforms, where size and power consumption are usually constrained. Execution scheduling and data movement in a heterogeneous environment are active areas of development and research in the GNU Radio runtime. GNU Radio can be used on embedded systems, such as ARM SoCs running Linux, as well as on more powerful desktop or server PCs. GNU Radio is frequently used as part of the ground station, both for standard protocols such as CCSDS and for custom modems. Some commercial ground-station-as-a-service solutions that support GNU Radio modems are Azure Orbital Ground Station and AWS Ground Station. Another example is the open-source community-driven SatNOGS network. GNU Radio is also very useful for prototyping and lab testing. Additionally, some small satellites run GNU Radio on-board, usually as part of a highly flexible SDR payload. Figure 11.18 shows an example GNU Radio block diagram (20).

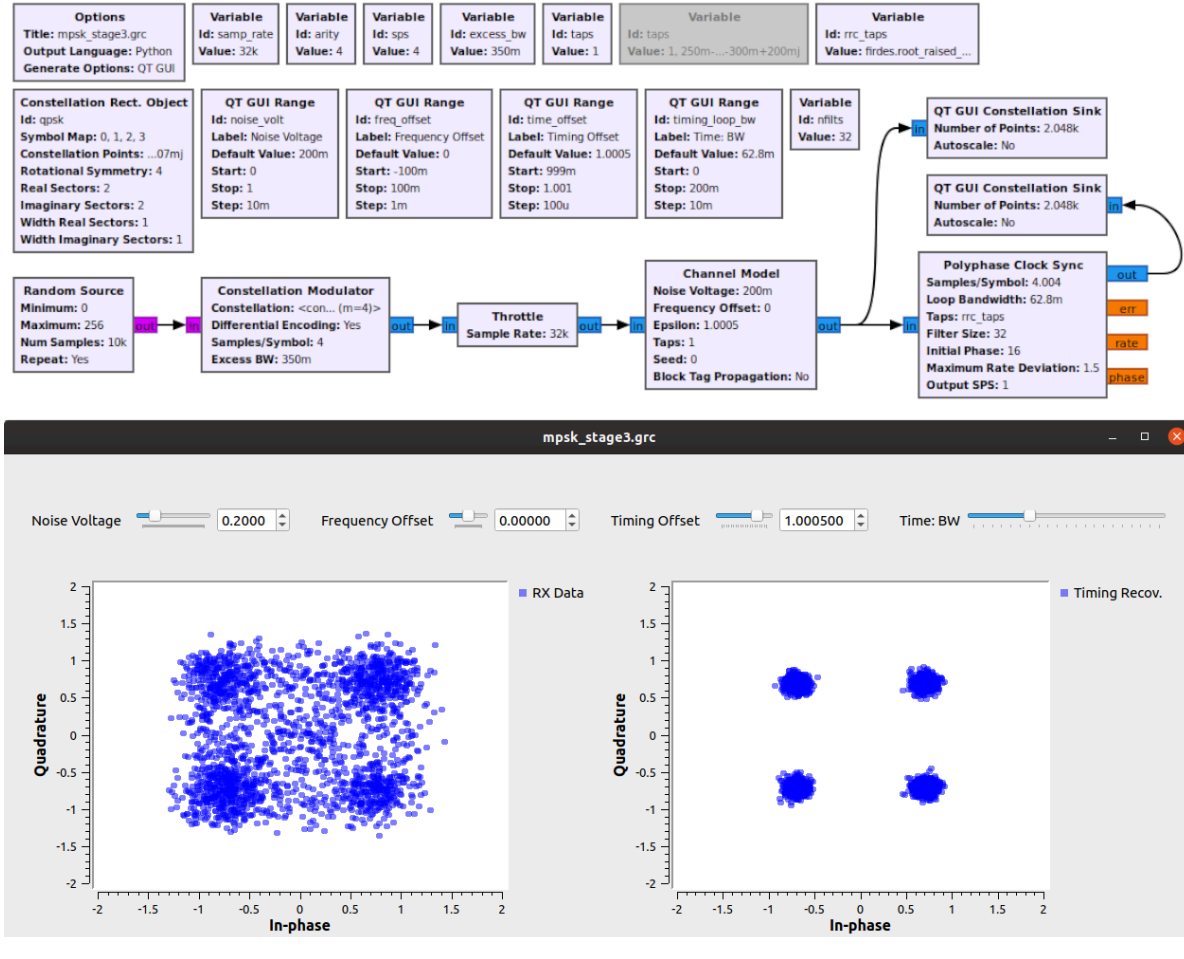

Figure 11.18: GNU Radio block diagram example for a 2-meter NBFM receiver. Credit: GNU Radio.

## HWCNTRL

HWCNTRL is a satellite ground station control program that is installed in more than 30 sites throughout the world. This automation software package can support multiple antennas and instruments simultaneously. Satellite passes are generated by user request based on the ephemeris set, and users can select specific passes to be added to the schedule. Scheduled events can be single-use or reoccurring on a daily or weekly basis. A control/status screen is accessible for each instrument in the system, and the user can view and change the settings of any instrument through these screens (21).

## 11.6 Mission and Science Operations Centers

The Mission Operation Center (MOC) is where all satellite commanding is generated, ground station control is managed, and satellite telemetry is archived. It is typically a physical location where everything required to operate the satellite is located. It is often in a secure room with controlled access to protect the satellite operating equipment and prevent unauthorized satellite control. Inside the room are typically several terminals so that multiple subsystem experts can be reviewing telemetry or running their analysis programs concurrently. An example of a MOC with multiple terminals is shown in Figure 11.19.





Figure 11.19: Mission Operation Center at NASA Ames Research Center. Credit: NASA

The size of the MOC is determined by the complexity of the mission. There are more experts on during critical events or to resolve an anomaly. For a SmallSat mission, the complexity is usually lower and the MOC is a much smaller room. In addition to the terminals and telemetry analysis software are other resources for managing the satellite. These may include physical models of the satellite to study when contemplating anomalous telemetry. In the case of CubeSats, due to their small size, a functioning spacecraft engineering model may be useful to test commands and reproduce anomalies.

All tasking requests for future satellite operations are managed by the mission operations team. They will generate command plans, simulate satellite response to verify those plans, and if confidence in the simulations is not sufficient, they will run the commands on engineering model hardware prior to approving them for upload. The MOC team will also manage downloads. They will decide what ground resources are available when. If the MOC does not own its ground stations, a request for contact will be submitted to the ground station managing company. The MOC submits data necessary for commanding the satellite for upload which includes commands and parameter settings for the payloads, a schedule of events for the flight computer, and ephemeris and pointing tables for the attitude control system along with its own timeline of events. When the contact is complete, the data will be sent back to the MOC by the ground station.

Prior to a launch, there will be rehearsals with everyone at their stations, and simulated telemetry with anomalous readings inserted will be used to test the team. This ensures that they are ready with the proper analysis software or integration test data available to quickly diagnose the problem and propose a plan of action. At the time of launch, the MOC will be fully populated, as this is a critical event. Telemetry will have to be interpreted and acted upon in short order.

The SOC is the focal point for all mission science data. The science team will use it to store and analyze the data. From that analysis, the science team generates satellite tasking requests that are sent to the mission operations team. External requests for additional data collection come through the science team first to assess feasibility with the instrumentation before tasking requests are made to the operations team.

The SOC is typically separate from the MOC. The payload developer will have their own operations center located at their facility with easy access to supporting resources. Before cloud





data storage, the SOC was a physical place where data servers resided to archive the mission science data. Prior to secure network solutions, dedicated computers were located inside the SOC that would run programs written specifically to analyze the science data. If the mission was secure and the data classified, then the physical SOC would be protected behind a locked door. Missions that do not produce classified data can take advantage of a virtual SOC instead of a physical location and the science data and special programs for analyzing data can reside in the cloud. The virtual SOC allows scientists to log on from anywhere and perform work without the need to come to a physical location and pass through secure doors. In the future, as cyber security techniques improve, it is likely that more and more secure missions will be comfortable with the virtual SOC solution and only the highest classification missions will maintain a secure physical SOC.

### 11.6.1 Software for Mission Operations

Mission operations rely on software across all the elements of the ground segment. Figure 11.20a outlines software functions for each of these elements. Satellite flight software not only manages state-of-health telemetry and payload data, but also software specific to the ground segment. Figure 11.20b provides an example of a command and telemetry data flow for a mission using DTE and relay services. Transmission can start autonomously by programming the satellite to know when it is over a ground station or within sight of a relay satellite. It can also be triggered by a command received from the ground station or relay satellite. When a communications link is established, the radio enters a higher power transmit mode and sends the data. The flight software manages the flow control of information into and out of the radio, making sure that no buffers are overflowed. It also formats the housekeeping and science data to be transmitted into a packetized file format that can be accepted by the ground station. Ground networks have specific data protocol standards developed from experience. For example, the NASA's NSN incorporates standards proposed by the CCSDS. The flight software unpacks received packets, retrieving the uploaded commands and data.

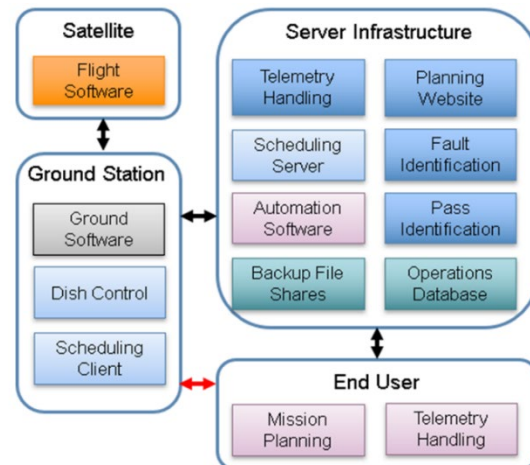

Figure 11.20a: Software functions for elements within the ground segment. Credit: NASA.

Software supporting the ground segment exists in the satellite, at the physical ground stations and in the MOC (server infrastructure and end-user software). The ground station uses various software for controlling the antenna, commanding, signal formatting and encoding, scheduling passes, and interfacing with the MOC. One software computes the pointing direction by using a Two-Line Element set (TLE) to define the satellite motion, an accurate model of the pointing system mount, and GPS time. It generates motor commands as a function of time. The motor controller uses these commands to actively track the satellite during a pass. During the pass, another software suite is used to monitor the link, process and encode commands for transmission, handle any signal formatting or encryption, and demodulate and decode the received transmissions. This software also manages the network connection with the MOC over which the TLE is passed, as well as data for uploading and requests for data to be downloaded. When the contact is complete, the data received from the satellite is transferred back to the MOC. The ground station may also have its own telemetry for that contact. That data is used to trend its performance. Trending the performance of each contact provides insight and notice of degradation for both the satellite and the ground station. The ground station may also use scheduling software when handling multiple missions. This software uses orbit simulation and current TLE information

to determine when the contacts are expected. It will indicate when there are conflicts between contact opportunities and can assist with schedule optimization. A schedule is generated for a given period and then programmed into the ground station control system for execution. This process can be automated, but there is typically an operator on staff to monitor the system.

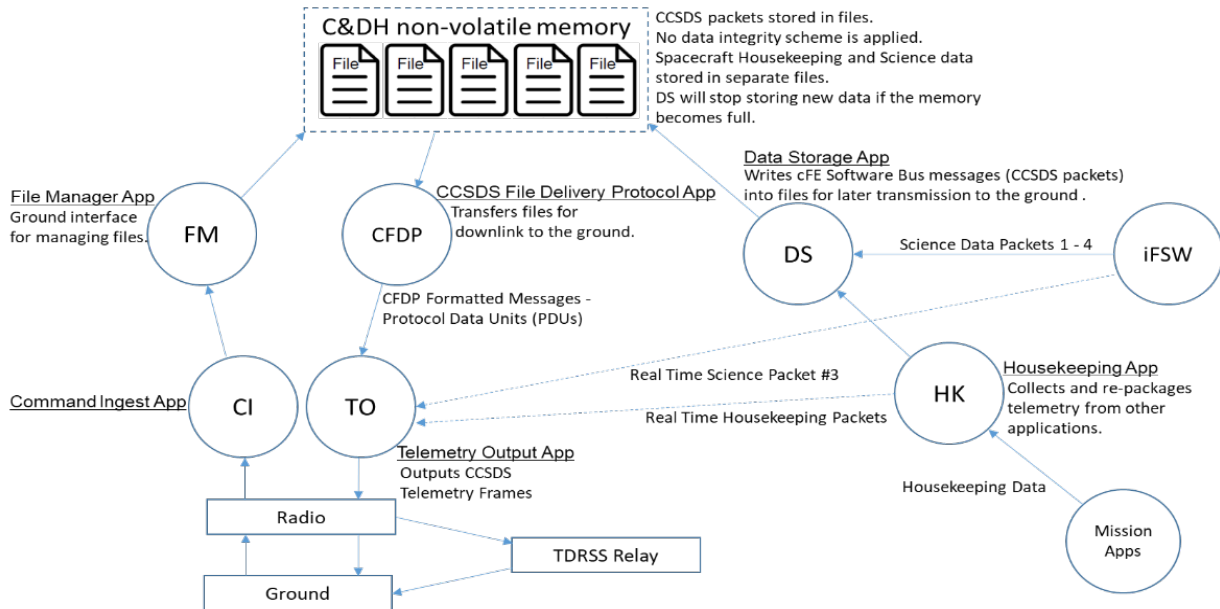

Figure 11.20b: Command and telemetry data flow for a SmallSat mission using DTE and relay services. Credit: NASA.

For the MOC, mission planning software is necessary for missions that require complex satellite behavior such as pointing at a target during science data collection. The software will include a model of the satellite dynamics and the capability of its components. The event is planned by listing a series of actions that must occur in a certain order and are spaced out by times that are approximated. The software will simulate the satellite response and then the times and actions are iteratively adjusted as needed to optimize the plan and not cause a satellite fault condition. The output of the plan is all the commands and databases that are required by the satellite. This output is submitted to the ground station ingest software for upload at a time prior to the planned event.

The SOC uses software to handle the receipt, unpacking, reconstruction and post processing of the mission science data. Using an ISS payload as an example, the science data is downlinked via TDRSS to NASA Marshall Space Flight Center (MSFC) where it is separated into different science streams and piped to the correct payload SOCs. At the SOC, but outside the company firewall, a computer is constantly running and ready to receive the data from MSFC. On that computer, the TReK software provided by NASA is running and it properly handshakes with the MSFC software assuring the data transfer. The science team periodically retrieves the data and safely brings it through the corporate firewall into the SOC. The science team writes parsing software to unpack the data which is stored in CCSDS format. They write another software to arrange the data back into the original image seen by the payload. Still more custom software will process the image to produce post-processed data products that are stored in the SOC archive and distributed to interested customers. The computer languages vary but Interactive Data Language (IDL) and Python are common choices for this type of software.



## 11.7 End-to-End Communications and Compatibility Testing

A SmallSat undergoes various tests through its development cycle to verify proper functionality. For the communication subsystem, end-to-end communication and compatibility testing with the selected ground network is its most critical test. Compatibility testing verifies that the ground station can properly communicate with the satellite on the uplink and downlink RF channels. Ideally, compatibility would be validated by testing the flight spacecraft with the actual ground station that will be supporting the mission. This may not be practical for larger or high-cost satellites, due to logistics associated with shipping and risk of damage. Two alternatives to shipping the satellites are typically used. One includes sending a replicate set of ground station hardware to the satellite facility for testing. A second option is to test with only the flight or an ETU radio (also common to include the flight computer) at the ground station or at a test lab configured with the ground station hardware. Drawbacks to the alternative options would include not testing the exact command path or determining whether ground sensitivity is sufficient.

For CubeSats, it is commonly feasible to bring the CubeSat to the ground station for testing. If that is not feasible, then at a minimum, the radio and flight processor (or Engineering Development Units [EDUs]) should be used. Testing at the ground station allows for the entire equipment chain to be part of the test, including the low-noise amplifier (LNA) and transmit/receive switch, if used. It is desirable to first test in a closed-loop configuration, where the satellite is connected to the ground system at the antenna port via a cable (with appropriate attenuators in line). If the satellite is fully integrated, disconnecting the flight antenna may not be feasible. In this case, a small monopole antenna located indoors near the CubeSat can be connected to the ground system. The monopole antenna connection to the ground system may vary depending on the ground antenna configuration but should include as much of the ground system electronics as practical.

Some missions elect to include an outdoor open-loop test with the CubeSat and ground antenna. This method allows for the entire ground system, including the ground antenna, to be included in the test. However, the ground antenna typically cannot point directly at the CubeSat due to mechanical limitations or to limit the received signal so the ground system RF components will not be overdriven. Off-pointing and reflections from the ground and local structures can also make it difficult to achieve a valid test.

End-to-end network testing primarily validates the ground station to MOC interface. This test verifies that the MOC can properly receive downlink data from the ground station and verifies that the ground station can receive and process uplink command data from it. Initial end-to-end testing will validate network connectivity, showing that network connections can be established and firewall rules at the ground station and MOC are in place. Once network connectivity is established, the MOC can transmit commands to the ground station for capture. The ground station can then transmit simulated or recorded data to the MOC for validation.

It is preferable to conduct initial end-to-end network testing prior to compatibility testing. In cases where the satellite can be brought to the ground station, a full end-to-end test can be conducted. Command transmissions from the MOC, through the network and ground system to the satellite can be validated. A complete end-to-end telemetry dataflow from the satellite to the control center can also be validated.

### 11.7.1 End-to-End Hardware for Ground Systems

A complete ground system can be provided as a kit with all the necessary components bundled together and setup to work seamlessly. These end-to-end solutions include the antenna, its controller, and the RF feed with all the necessary filtering and low noise amplification for the particular wavelength of interest. They use a software defined radio or a dedicated transceiver to convert between digital packets and RF waveforms. Software is included to process the satellite

position and direct the antenna to track it. Additional software is used to archive and display the information within the digital packets. Three vendors, GAUSS, Innovative Solutions In Space (ISISPACE) and GomSpace, listed in Table 11-12 provide solutions for the low-cost CubeSat and small satellite market. One vendor, Surrey Satellite Technology Limited, offers a higher end system, installation service, and personnel support. The final vendor listed, Kratos, offers a different end-to-end solution that begins with the digitized RF waveform. The Kratos Quantum software then demodulates, filters, unpacks, parses, displays, and archives the data (17).

Product	Manufacturer	TRL	Type of Product
Complete Ground Solution	GAUSS	9	Small satellite provider offering a complete ground solution. UHF, VHF, and S-band
Complete Ground Solution	ISISPACE	9	Small satellite provider offering a complete ground solution. UHF, VHF, and S-band
Complete Ground Solution	GomSpace	9	Small satellite provider offering a complete ground solution. UHF, VHF, and S-band
Surrey Ground Segment	Surrey Satellite Technology Ltd.	9	Major contractor offering a complete ground solution. S-band uplink/downlink and X-Band downlink capability
Quantum	Kratos	9	Major contractor with a complete ground solution

### GAUSS Ground Station Kit

The GAUSS ground station is a turnkey solution. It can be configured with UHF, VHF and S-band on the same pointing system. An example of the associated hardware is shown in Figure 11.21.



Figure 11.21: (left) GAUSS ground station hardware, transceiver and (right) tracking antenna. Credit: GAUSS Srl.

Hardware features of the systems offered include (22)(23)(24):

- High gain Yagi-Uda VHF and UHF antennas (>16 dBi for UHF)
- Low-noise amplifiers and band-pass filters for VHF and UHF bands
- Low-loss RF coaxial cables
- 1.5-meter parabolic dish for higher frequencies downlink (up to 6 GHz, default feed is for S-band)
- VHF: uplink and downlink up to 100 W using radio and Terminal Node Controller (TNC),



software defined radio (SDR) optional

- UHF: uplink and downlink up to 70 W, using radio and TNC, SDR optional
- TX using ICOM-9100 hardware, RX recording and decoding via SDR
- Several RF and electrical fuses for lightning protection
- S-Band: downlink using SDR for recording and post-processing of I/Q RF data
- Az/EI rotor for high-torque maneuvering
- Hardware components power switch on/off to minimize power consumption
- Full HD camera for instant antenna monitoring and picture logging

The features of the software that accompanies the system include:

- Automatic TLE download from publicly available repositories
- SGP4 propagator as suggested by USAF NORAD's Space-Track
- Rotor control (compatibility with several rotor controllers, e.g. Yaesu, RF Hamdesign)
- Assisted rotor pointing calibration and verification using Sun position
- Fully compatible with ICOM-9100 satellite radio and GAUSS USB ground dongle
- Separated Doppler shift corrections for uplink and downlink frequencies
- DUPLEX TX/RX mode
- Instant weather check and logging to operate the ground station safely
- Lightning detection for safe antennas operation
- Instant logging of all subsystems operation
- Ground map with live Earth clouds
- Compatible with several TNCs (Kantronics, Symek, Paccomm, Kenwood)
- Email report to ground station operators
- Instant email alerts for non-nominal conditions of the satellite or GS hardware components
- Session programming for weeks of unattended ground station operations
- GUI command recording for easy session programming
- One button programming to include a whole set of commands in the session
- Manual override during pass for last-minute command addition
- Control and handling of multiple satellites using configurable priorities
- Satellite TLM decoding, graphing, and archiving into a database accessible by web
- Integrated satellite payload data handling and decoding (e.g., for image file processing)
- TCP/IP connections for remote ground station & TNC operations

### **Innovative Solutions In-Space Ground Station Kit**

The ISISPACE small satellite ground station is a low-cost, turnkey solution that is designed to



communicate with satellites in low-Earth orbit that operate in either amateur frequency bands or commercial bands. The frequency bands covered are S-band, UHF, and VHF. The ground station consists of an antenna and a 19" rack which houses the transceiver, rotor control and computer which make the system very compact. Examples of these components are shown in Figure 11.22. The transceiver makes use of a SDR that provides flexibility to swiftly reconfigure modulation/coding/data-rate on the run. Most commonly used modulation schemes and coding methods are already implemented, and any customization requests can also be handled (25).



Figure 11.22: (left) ISIS ground station hardware, transceiver rack and tracking antenna (right). Credit: ISISPACE.

### GomSpace Ground Station Solutions

GomSpace offers two products (A) NanoGround, and (B) Hands-off Operations Platform (HOOP) that can be used as ground segment building blocks for a wide variety of missions.

A.NanoGround provides a communication gateway for spacecraft using GomSpace AX2150 and NanoCom Link S/SX S-band and X-band radios. NanoGround provides TMTC link over S-band as well as IP networking over S and X-bands and is designed to be easily integrated with commercial ground station service providers. As of September 2024, NanoGround offers built-in integration for KSAT's ground station network. AWS Ground Station and LeafSpace ground station network support will be released in the near term. Other ground station networks are being considered and can be discussed based on client need.

B.HOOP is GomSpace's Mission Control software solution, providing autonomous "hands-off" satellite operations for single spacecraft and constellations. HOOP can either be operated by GomSpace's Mission Operations Team for client missions or it may be purchased by clients on a subscription basis to manage their own missions. HOOP comes pre-built with integration for GomSpace NanoGround, providing out-of-the-box solution to operate missions flying GomSpace satellites. HOOP's capabilities will be expanded in the near term with an up-coming release to support CCSDS communication protocols. This expanded capability will allow HOOP's application domain to include 3rd party satellites. HOOP has been in operation since 2020 and currently manages LEO missions. As of September 2024, five additional HOOP missions are in development and planned for near-term execution (26).

### Surrey Satellite Technology Ltd. Ground Station Kit

Surrey can provide complete turnkey ground segment solutions for a range of space platforms, including all the hardware and software necessary to operate, maintain, process and archive data. Services provide by Surrey include:

- S- and X-band ground stations with full motion antenna systems from 2.4 meter to 7.3 meter in diameter, with radome options available for harsh climates



- SSTL Pilot Satellite Control Software
- Mission planning systems
- Radiometric and geometric image processing
- Data storage solutions
- Site surveys, groundsegment installation and training
- Technical and maintenance support packages

In addition, Surrey can work with customers to integrate their ground segment solutions with existing ground infrastructure or with 3rd-party ground station networks (27).

### Kratos Ground Station Solutions

Kratos virtual ground solutions begin with the OpenSpace SpectralNet digitizer converting analog signals at RF frequencies up to S-band into digital IF VITA-49 or DIFI IP packets. Kratos quantum virtualized network functions (VNFs) then process the digitized RF waveform. Kratos virtualized network functions run on general-purpose compute and can be dynamically instantiated for different mission directives at the click of a button. Figure 11.23 provides a visualization for the system concept.

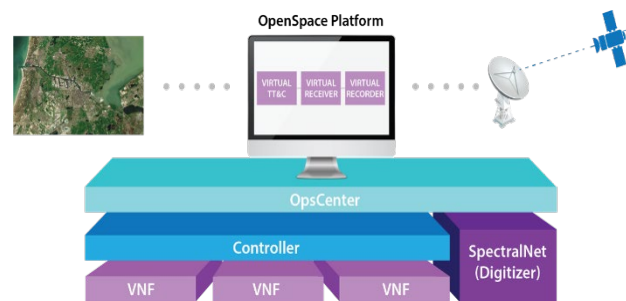

Figure 11.23: Visualization for the Kratos quantum system concept. Credit: Kratos.

All components are available separately to support an existing C2 solution or third-party ground network with existing signal processing and antenna resources. The quantum products include:

- 1) quantumCommand (qCMD), COTS software application for command and control (C2) of small spacecraft;
- 2) quantumFEP (qFEP), connects C2 systems to RF signal processing equipment: handling command and telemetry stream formatting, encryption/decryption devices, CCSDS processing, and network interfaces to either qRADIO or third-party ground antenna networks;
- 3) quantumRadio (qRadio), the software modem for RF signal processing on premise or in the cloud;
- 4) quantumDRA (qDRA), a data recording and archiving application supporting CCSDS/non-CCSDS header and channel data routing with IP-based interfaces;
- 5) quantumRX (qRX), a fully virtualized wideband software receiver, specifically tuned to streaming earth observations in near-real time with 500 MHz bandwidth using Digital IF digitizers;
- 6) quantumTX (qTX), a fully virtualized wideband software transmitter, specifically tuned for Earth observation and remote sensing satellites with over 1Gbps throughput for uplinks.

In 2021, Kratos introduced a virtual, software-defined architecture solution called the OpenSpace Platform. As an enterprise level, end-to-end system, it provides satellite operators and service providers the flexibility to scale on-demand as their operations grow in size and capability. By leveraging Digital IF over IP with time deterministic latency and software defined networks, the platform allows virtualized functions such as modems, channelizers, recorders and combiners to be orchestrated on generic servers in a ground station or public or private cloud environment. The

virtual architecture lends itself to upgrades and/or updates automatically, ensuring ongoing

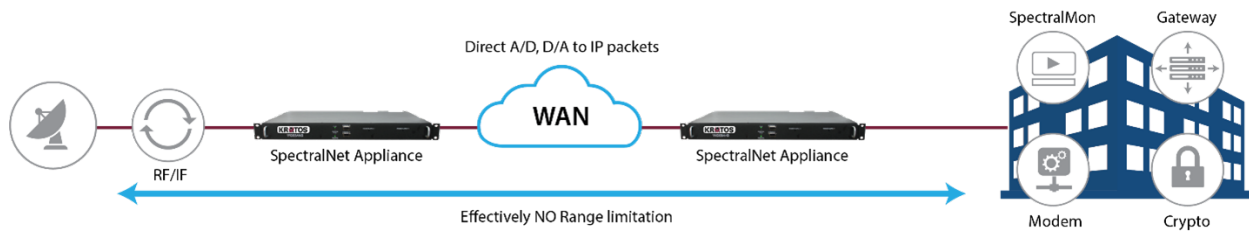

Figure 11.24: Kratos OpenSpace architecture concept keeps most of the RF ground equipment remote from the ground station. Credit: Kratos.

reliability and security. In addition, the ability to test software releases in real-time allows ground equipment functions to be included in continuous integration and continuous delivery cycles. Software defined architectures are more agile, programmable, and automated, enabling the ground system to work in tandem with dynamic satellite payloads. By shifting from RF signals and analog equipment to a virtualized, IP-based infrastructure, orchestration can occur on the fly. Figure 11.24 provides an illustration of the OpenSpace architecture concept (29).

## Remos Space

Remos Space offers a versatile multi-mission software modem called Expedite that is designed specifically for the new space segment. Expedite can reconfigure modulation, coding, and data rates on-orbit, allowing it to adapt to different mission requirements dynamically. There are three configurations available: a plug-and-play system can be integrated directly into existing ground systems and includes a COTS 4U server with an integrated SDR and Remos software; the turnkey solution includes the software modem and necessary hardware such as antennas, sequencers, High-Power Amplifiers (HPAs), Low-Noise Amplifiers (LNAs), and other related components for a complete ground station setup; and the pure soft modem allows customers to deploy the modem software on their existing infrastructure, with licenses charged annually. Expedite is highly compatible with various spacecraft transceivers and does not require a specific transceiver for integration, making it a flexible choice for various mission profiles. Their antenna size ranges between 1.9 – 2.4 m with plans to supply larger apertures in the future. Remos Space is currently adding VITA49 and DIFI to Expedite that will enable seamless integration of the pure software modem with Amazon ground stations.

## 11.8 Cyber Security

Security of a space system needs to consider all aspects of the system, including the space platform, payloads, and all supporting functions. To a remote attacker, the most accessible portion of a spacecraft is the end-to-end command path as accessed through direct contact (RF link), subversion of any command path transports (space or ground networks), and subversion of the command authority (e.g., MOC). Another enticing option for an attacker is to cause a mission impact through manipulation of key space system dependencies, such as the Global Navigation Satellite System (GNSS), ground stations, and external service or data providers. Related concerns include degrading or denying the use of the command path through jamming or denial of service of the command path and supporting functions. Finally, vulnerabilities in any system, sub-system, or component, can be exploited by an attacker in creative ways to ultimately gain the ability to affect the overall system. Supply chain risk management is needed to address some portions of these challenges.

Effective space system security efforts begin early in the lifecycle and continue through to mission termination. Early architecture and design decisions will have the most significant impact on the



overall system's security outcomes and can help avoid rework in later phases. Integrating cybersecurity capabilities into a system fits well into standard system engineering practices. Many organizations are establishing a sub-discipline for systems security engineering, to serve as a focal point within the mission team to enable system security. This may overlap with or work closely with related roles such as a cybersecurity systems engineer. The International Council on Systems Engineering (INCOSE) has established a working group to support system security engineering, and NASA is actively implementing a system security engineering capability (30).

Operators need to maintain command authority over their spacecraft, preventing unauthorized access. Use of authenticated encryption, between the point where the command sequence is generated and the spacecraft, is the best method to ensure command authority and data integrity. Encryption provides confidentiality, and authentication ensures that a trusted source initiated the command. This approach generally addresses initial concerns about an attacker attempting to gain access through use or subversion of the command path to the spacecraft.

Key spacecraft external dependencies can be manipulated to cause a mission impact. Example dependencies might include the ground station and GNSS signal. Ground station impacts could disrupt data flows with the spacecraft. Jamming and measurement spoofing of GNSS signals has become common in various regions, with observed impacts in the maritime and airspace domains. Orbiting systems have detected similar effects. Space systems should be prepared to tolerate loss or interference with GNSS signals.

For the overall space system and its component parts to function properly and securely, each part must in turn be sufficiently secure. Traditional cybersecurity efforts apply well to most software and terrestrial systems. Attention to the security of each component, as well as ensuring the interplay between components is secure, will help protect the overall system. On-board security should also be considered, particularly for multi-customer and multi-payload spacecraft. Increasingly, spacecraft developers should consider that external defenses (e.g., command authentication or encryption) may be bypassed or subverted (similar to how network firewalls may be bypassed). Without further consideration, the on-board systems are likely vulnerable to further exploitation.

Supply chain risk management is an essential related discipline. Particularly for key components and software, understanding the vendor's sourcing, manufacturing approach, and cybersecurity and assurance management will help ensure any associated risk can be identified and managed. If a vendor relies on other vendors, additional scrutiny may be appropriate. Review of the sourcing may address whether the vendor is rebranding, assembling/integrating, or internally manufacturing components, and whether there is sufficient control to deliver a trustworthy product. Reviewing the manufacturing approach, whether hardware, software, or some combination, allows the customer to determine whether the vendor uses repeatable processes that yield deterministic and trustworthy results. And understanding how the vendor addresses cybersecurity, quality, and protection topics in their components provides insight into whether or not it is appropriate to integrate the component into the overall system.

### **U.S. National Guidance and Regulations**

In September 2020, the U.S. National Space Council issued Space Policy Directive 5 (SPD-5), Cybersecurity Principles for Space Systems. Amongst other elements, the directive calls for use of "risk-based cybersecurity-informed engineering," anticipating and adapting to evolving malicious activities, and recommending capabilities to maintain positive control of space vehicles. Another element implies that Federal agencies may issue or update guidance, rules, or regulations to adopt the principles in this directive (31).

U.S. regulatory agencies, such as the Federal Communications Commission (FCC), have



considered and not yet issued rules that may require specific cybersecurity measures to be adopted. Prior proposed (and not issued) rules included requirements for encryption on the telemetry, tracking, and command communications for propulsive spacecraft.

### **U.S. Agency Guidance**

Several U.S. government agencies and their support ecosystem have made various frameworks, standards, and other guidance available to address cybersecurity and protection concerns.

#### **NASA Technical Standard**

NASA requires its missions, including small satellites, to comply with NASA STD-1006 “Space System Protection Requirements.” This standard covers protection of the “command stack,” critical information, Position Navigation and Timing (PNT) sub-system resilience, and reporting detected and unexplained interference. The tailoring guidance within the standard allows for some flexibility in certain small satellite scenarios, such as non-maneuverable systems. Protecting the command stack involves use of encryption complying with FIPS 140 (level one). PNT resilience addresses the loss of or temporary interference with external PNT services, such as a GNSS (32).

#### **National Institute of Standards and Technology (NIST)**

NIST has several useful publications addressing cybersecurity and system security engineering. The NIST Cybersecurity Framework is a voluntary guidance framework that can be used by organizations to manage cybersecurity risk. The framework provides a structured and tailorable approach for organizational security capabilities and includes informative references to other NIST documents (e.g., SP 800-53), as well as other standards or guidance organizations (e.g., International Organization for Standardization, ISO). NIST’s SP 800-160 Volumes I and II offer a thorough approach for system security engineering practices. In particular, SP800-160 Vol I’s Appendix F, Design Principles for Security, can be used as an effective foundation for systems security (33)(34)(35)(36).

#### **Additional Resources**

Two U.S. Federally Funded Research and Development Centers (FFRDCs), the Aerospace Corporation (37) and MITRE (38), have published guidance for space system cybersecurity. These FFRDCs are expecting to make additional recommendations widely available. Aerospace’s “Defending Spacecraft in the Cyber Domain” includes a brief survey of known cybersecurity initiatives and standards, challenges with legacy engineering approaches, emerging threats, and principles for “cyber-resilient spacecraft.” The paper also includes a section specific to small satellites. MITRE has published a paper “Cyber Best Practices for Small Satellite” that briefly addresses cyber threats to space systems and includes a discussion on applying lessons learned from other industries to space systems.

#### **Consultative Committee for Space Data Systems (CCSDS)**

CCSDS provides a variety of guidance documents for implementing security measures in various aspects of the mission. For an introduction to the CCSDS approach and available guidance, see CCSDS 350.7-G-2 “Security Guide for Mission Planners” that provides a perspective on approaching security in space systems (39). The CCSDS 350.0-G-3 “The Application of Security to CCSDS Protocols” informative guidance document provides an introduction and discussion on various topics, including protecting the command path (40).

## **11.9 State-of-the-Art – Ground Data and Supporting Systems**

### **11.9.1 Technologies**

## Multiple Spacecraft Per Aperture

The Annual Small Satellite Conference on the grounds of Utah State University is the premier event amongst small satellite stakeholders, and its themes reflect the trends of the times. In 2021 one of the key talks was on how to “Maximize Contact Availability of SmallSat Clusters through MSPA Technique on GSaaS,” (41).

As scientists are increasingly interested in characterizing fields (going beyond single point measurements) requiring swarms of satellites, as well as the emergence of Distributed Satellite Missions (multiple satellites working in concert towards one common goal), MSPA is a critical enabler. While it is not a new concept, few ground stations have invested in such upgrade. The DSN has the capability to track multiple spacecraft per antenna (MSPA) (up to four) if they are all within the scheduled antenna’s beam. The 34 m antennas at each complex can be combined into an array, with or without the co-located 70 m antenna. The combined G/T depends on several factors but is approximately increased by the sum of the antenna areas from the arrayed apertures minus approximately 0.3 dB combining loss. For instance, arraying four 34-meter antennas results in an increase of 5.72 dB.

## Automation and Modeling

The MOC of the future will include a “lights out” or fully automated option. This requires software on the ground station side to run the antenna automatically. Automation software will receive a list of times that the antenna should track the satellite and it will manage that list. It will send TLEs and data to the antenna with no one present, receive downlinked telemetry, and archive it. Software automatically parses the telemetry, compares key watch items to defined limits, and alerts the team via email or phone text message. FreeFlyer by AI solutions combine astrodynamics/ spacecraft propagation, coverage and contact analysis (including swarms), attitude and maneuver modeling, and orbit determination (42).

## Large Ground Antennas: to the Moon and Beyond

For years there had been a gap between NSN’s largest 18m and DSN’s 34/70m antennas, and such large antennas were not available from commercial ground providers. This gap has now been filled.

In 2022 Viasat introduced new 19/24m aperture antennas (Figure 11.25) at their Antenna Systems campus in Duluth, GA supporting several ongoing programs. The size and architecture of these larger apertures support current programs while offering the flexibility and scalability to support future and forward planning missions (43).



*Figure 11.25: Viasat’s new large-aperture space-to-ground communication antennas are ready to support lunar, cislunar, deep space and DoD missions. Credit: Viasat.*

## NASA Lunar Exploration Ground Sites

SCaN announces Lunar Exploration Ground Sites (LEGS) to provide direct-to-earth communication and navigation services for missions operating from 36,000 kilometers (km) in the





GEO to cis Lunar and other orbits out to 2 million km. To fully support distant orbits there will be three LEGS sites equally spaced around the Earth. The Ground sites use CCSDS Modulation and coding schemes for forward and return data. Specialized/unique Mod-Cods are optional. User Local Equipment on-site is optional. The 18m assets are listed as White Sands, USA: 32.544863, -106.612504 Matjiesfontein, South Africa: -33.231224, 20.58163 (TBD) and Pacific Region TBD. MSPA is planned for up to 4 simultaneous return services per aperture (Max 3 for Ka). Use of LEGS for other than Artemis support is TBD. See Table 11-13 for projected performance of LEGS assets.

<b>Table 11-13: Projected Performance of LEGS Assets Pending Finalization</b>			
<b>RF Performance Criterion</b>	<b>Radio Frequency Performance (Return)</b>		
	<b>S-Band</b>	<b>X-Band</b>	<b>Ka-Band</b>
G/T (minimum)	28 dB/K	39 dB/K	47.5 dB/K

### 11.9.2 Ground Aggregators

Table 11-14 lists those Ground Service providers who own and or operate their own brand of ground assets. Irrespective of the nature of ownership, satellite operators are reliant on the limited ground stations they have access to. Satellite operators have well defined windows for exchanging information with their satellites. To meet evolving demand from within the fast-growing segment of the space industry, multiple aggregator models have evolved from private market participants. Services from companies such as RBC Signals, Infostellar, Amazon Web Services, and Spaceit are offered through specialist ground station capacity aggregator platforms. These are digital solutions enabling ground station operators to provide their excess capacity to a global user base. Since this is very similar to the business model of Uber, these aggregator services represent the ongoing “Uber-ization” of ground station services within the space industry. The downstream service markets are observing new players with new products and services. With increasing competition, the differentiating factors are shrinking in number. When the upstream capabilities start resembling each other, the key differentiators will include the ability to communicate with the satellites on-demand (44).

#### RBC Signals

RBC Signals is provider of global satellite data communication products and solutions. It offers secure space communication solutions in every major frequency band using a worldwide network of company-owned and partner-owned systems. RBC Signals delivers dynamic solutions offering affordability, flexibility, and resiliency. Its diverse products and services offer complete end-to-end solutions for best-in-class multi-network solutions (see <https://rbcsignals.com>).





RBC has aggregated a growing network of over 80 antennas in nearly 60 locations worldwide offering unmatched capabilities. A map of these locations is shown in Figure 11.26. As of 2024, RBC owns about 20% of the ground stations, and the rest are partner stations. For customers needing turnkey access to existing antennas, RBC Signals offers ground station antenna-as-a-service, with the flexibility to secure unlimited satellite passes (“core”) or ‘pay-by-the-pass/minute/GB’. This is made possible through a combination of their own network of highly capable systems and the unique ‘sharing economy’ model, wherein they leverage the unused excess capacity of dozens of partner-owned antennas worldwide. RBC Signals also offers turnkey bring-your-own-antenna hosting solutions that pair customer-owned equipment with reliable, high-end ground infrastructure almost anywhere in the world. RBC employs a distributed compute architecture where most processing occurs at a data center/cloud, with some processing on the satellite or at the terrestrial edge at the ground station. RBC Signals can host AWS and Microsoft on premise cloud infrastructure, as well as virtual servers at the ground. Most recently, RBC has a new additional service for intersatellite links called Go.BIC, a partnership with IQ SpaceCom and Viasat (45).

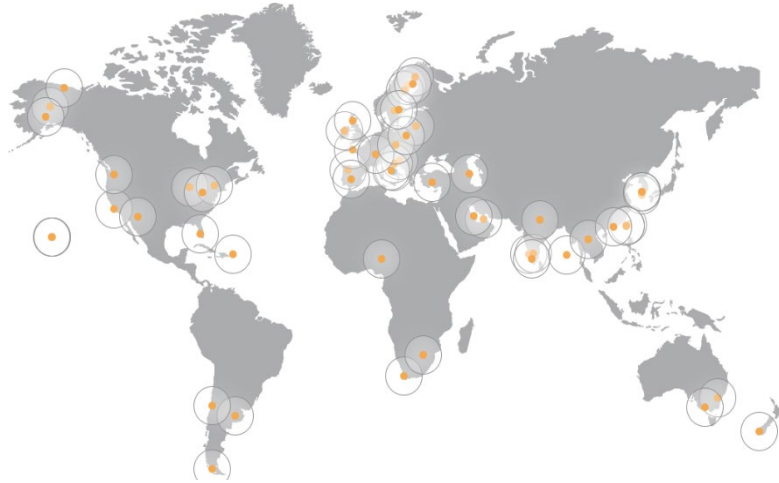

Figure 11.26: RBC Signals ground network map September 2024. Credit: RBC Signals.

Table 11-14: Service Providers for DTE Ground System Network			
Product	Dish Sizes	Services	MSPA
ATLAS Global Network	Various partners with other stations	S-band, X-band, UHF (Ka-band in 2017) Built on AWS cloud infrastructure	Partner dependent
KSAT and KSAT <sup>LITE</sup> by Kongsberg Sat. Services	> 10 m part of NSN or 3.7 m (KSAT <sup>LITE</sup> )	X-band and S-band D/L and S-band U/L. VHF, UHF, Ka-band D/L. KSAT <sup>LITE</sup> designed specifically for SmallSats	No
SSC Infinity by Swedish Space Corporation	13 m, 7.3 m NSN partner	Designed specifically for SmallSats; Uses standardized HW	Not found
AWS Ground Station by Amazon	5.4 m	Built on AWS cloud infrastructure	Not found
Viasat	7.3 m, 5.4 m	Global network operating in S, X, and Ka-bands that can reach LEO, MEO, GEO, and HEO orbits	Mission Dependent
Leaf Space	3.7 m	Standardized global network accessible through UHF, S, X and Ka-band	Yes



NASA, Near Space Network	9 to 11 m, & 5 m	Global network operating in S, X, and Ka- bands that can reach LEO, GEO, HEO, and Lunar orbits; up to 2 mil km	Legacy: NoLEGS (18m): planned, Yes
NASA/ JPL, Deep Space Network	34 m, 70 m	Operating at S, X, K, Ka bands. Includes Morehead State 21m in X-band. 8 m optical receive aperture planned for 2030s	Yes
NASA UHF Ground Station	18 m	Operates in UHF (400 – 470 MHz)	No
RBC Signals Global Ground Station Network		VHF, UHF, S, C, X, Ku, and Ka-bands	Partner Dependent

### 11.9.3 Scheduling and Mission Operations Software

With the growing number of ground operators and aggregators, to take advantage of the plethora of assets, scheduling is emerging as the single most important enabler. As individual providers may have their own scheduling formats, for seamless operations, a common scheduler is critical, and this is true for the NASA commercialization efforts as well.

#### Scheduling: InfoStellar

InfoStellar offers communication services in the VHF, UHF, S, X, and Ka bands. Table 11-15 lists the frequency bands offered by InfoStellar which can be filtered by the tool on their website. Figure 11.27 shows all 34 antennas on the platform that are either live or for which integration is planned. With multiple commercial small-satellite operators in the market, the need for enhanced mission operations is much more than an industry-wide requirement (44).

Downlink		Uplink	
X Band 8 – 12GHz	S Band 2 – 4GHz	S Band 2 – 4GHz	UHF Band 300MHz – 1GHz
Ka Band 27GHz – 40GHz	None No Uplink Channel	VHF Band 30 – 300MHz	None No Uplink Channel

The following section provides an overview of mission operations and scheduling software products that can be integrated into a MOC (see Table 11-16). While the specific aspects of each of these products is discussed below, they all have some common features. In general, these software applications cover functions related to mission scheduling and tasking, commanding and telemetry, and monitoring and control. Many of them also have automation features that enable “lights-out” operations or reduced manpower requirements.



All these products are highly customizable. They can not only adapt to multiple missions, satellites, and ground stations, but these products also allow for customized visualizations, analyses, and user interface views. Additionally, many of these products are cloud-based or have a web interface to enable easier access for an operator from almost anywhere.



Figure 11.27: All 34 antennas on the StellarStation platform that are live (25 - red) or for which integration is planned (9 - blue). Credit: InfoStellar.

**Table 11-16: Mission Operations and Scheduling Software**

Product	Manufacturer	TRL	Type of Product
COSMOS	OpenC3	9	Open-source command and control system that can be used in all phases of testing and operations
Galaxy	The Hammers Company	9	Command and telemetry system that has been available since 2000
Orbit Logic Family of Products	Orbit Logic	9	Group of mission planning and scheduling products for both aerial and satellite imaging applications
Yamcs	Space Applications Services	9	Open-source command and control system
ACE Premier Family of Products	Braxton Technologies	8+	Group of hardware and software components for end-to-end Satellite Operations Center (SOC)
Mission Control Software	Bright Ascension	8+	Monitoring and control interface with “lights-out” automation features built-in
Major Tom	Xplore	8+	Cloud-based command and telemetry system that can interface with some COTS flight software

## OpenC3 COSMOS

OpenC3 COSMOS is a free, open-source, open-architecture, command, control and communications system providing commanding, scripting, and data visualization capabilities for embedded systems and systems of systems. With the release of version 5, COSMOS is now a fully containerized, microservice-based architecture with a web frontend. COSMOS is intended for use during all phases of testing (board, box, and integrated system) and during operations. OpenC3 COSMOS is made up of a set of applications that can be grouped into four categories: real-time commanding and scripting; telemetry visualization; offline analysis; and utilities. Figure 11.28 shows how data flows through the microservices and is made available to users through an API and from a web-based interface. Any embedded system that provides a communication interface can be connected to COSMOS. All real-time communications of both commands and telemetry are logged in a cloud-native data store, which can use local hardware, or cloud-based buckets for potentially infinite storage.

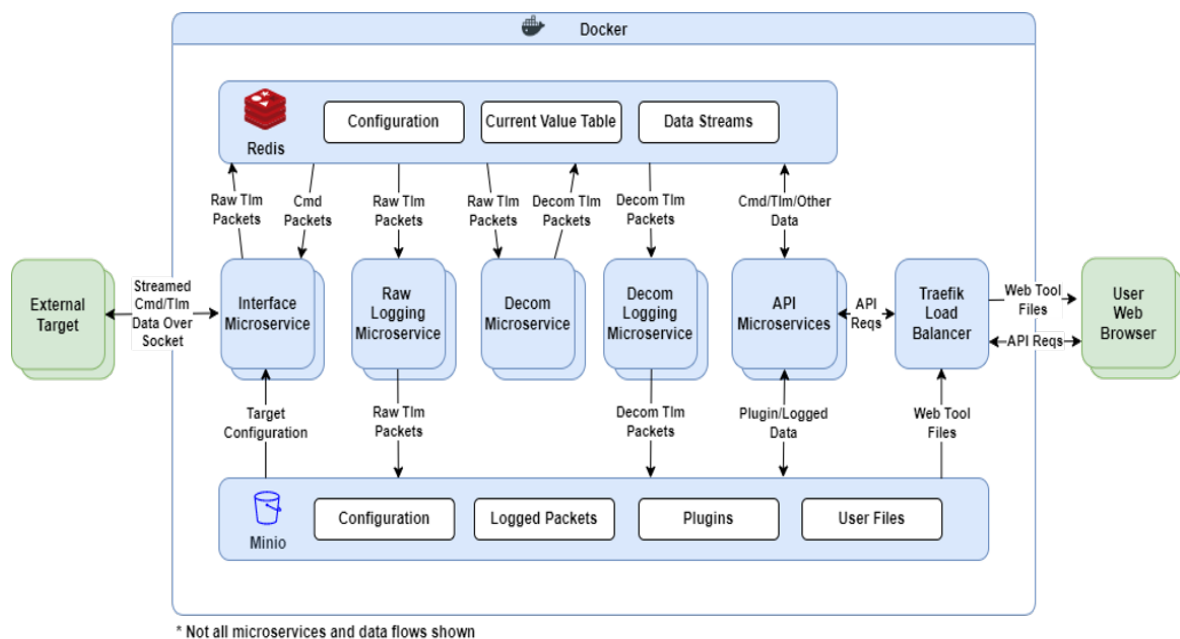

Figure 11.28: COSMOS5 architecture and context diagram. Credit: OpenC3, Inc. <https://openc3.com/>

Additionally, program specific tools can be written using the open-source OpenC3 COSMOS libraries, and these tools can interact with the commands and telemetry of all targets connected to the system. A paid enterprise edition of COSMOS is also available that adds on important scaling and security features including: user accounts, Role Based Access Control (RBAC), Kubernetes support with helm charts, calendar and automation capabilities, and a library of prebuilt plugins for common devices and protocols like SCPI devices and CFDP (45).



## Galaxy

GALAXY is a real-time command and telemetry system intended for use throughout the spacecraft, instrument, and/or component life cycle from development through integration and on-orbit operations. GALAXY has been used on missions ranging from stratospheric balloons and CubeSats through great observatories and interplanetary missions. GALAXY can accept telemetry from, and send commands to, multiple spacecraft and ground stations simultaneously. It can perform uplink authenticated encryption and downlink decryption and authentication. Users can customize GALAXY for a particular mission via a database in which they provide telemetry and command specifications. Users can design telemetry displays, plots, sequential prints, configuration monitors, and spacecraft commands and table loads in simple text files stored on the host computer's file system. GALAXY is CCSDS compliant, and can communicate over a wide variety of transports and protocols including TCP/IP networking (optionally with TLS), synchronous and asynchronous serial ports, SpaceWire, MIL-STD-1553, and the GMSEC message bus (47).

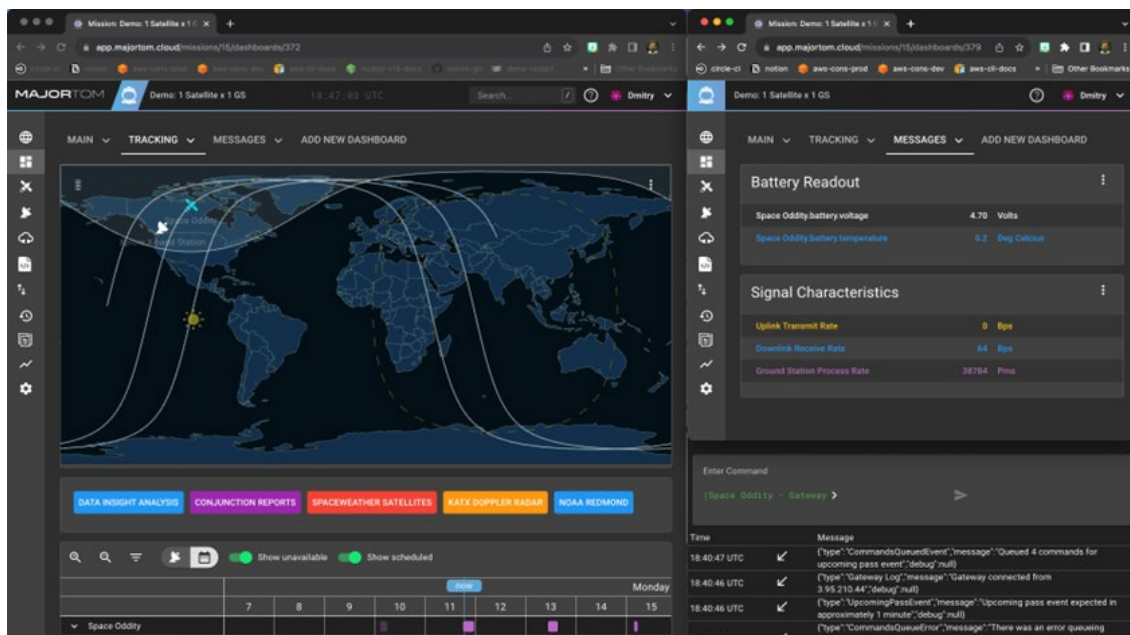

Figure 11.29: Major Tom's configurable dashboards allow operators to oversee and interact with the mission in the way they are most comfortable. Credit: Xplore.

## Major Tom

Xplore's Major Tom® is a scalable, cloud-based mission control software that provides satellite mission operations and planning tools for ground station scheduling, satellite tasking and telemetry monitoring. It provides satellite operators the ability to integrate and control ground segment applications and services, and further de-risks mission operations with features that include out-of-the-box ground network integrations, data analytics, real-time dashboards, and a customizable commanding API. Major Tom's gateway API architecture, definitions, and protocols can integrate with custom ground station provider(s). This software is compatible with a heterogenous network of ground station providers and supports constellation and mission operations flexibility in satellites communication and commanding. New ground station network locations and providers can be added, and the same data model will unify accessing their functionality. Interface capabilities include control panel scheduling and pass management as well as data interface for downlink and uplink. Integrated ground station providers are ATLAS Space Operations, Inc., Leaf Space and Microsoft Azure Orbital. Figure 11.29 provides a screenshot of





the dashboard (48).

### Orbit Logic Family of Products

Orbit Logic specializes in mission planning, scheduling, and space situational awareness software. The software suite consists of multiple applications that support analysis and operations for aerial and satellite imaging and space-to-ground networking. The mobile, web, desktop, and onboard scheduling applications have a variety of features, including: configurable systems, constraints, and goals; high performance algorithms; deconflicted scheduling plans; visualizations and animations on the user interface, and flexible process flows and automation. Figure 11.30 shows Orbit Logic's Collection Planning and Analysis Workstation (CPAW) (49).

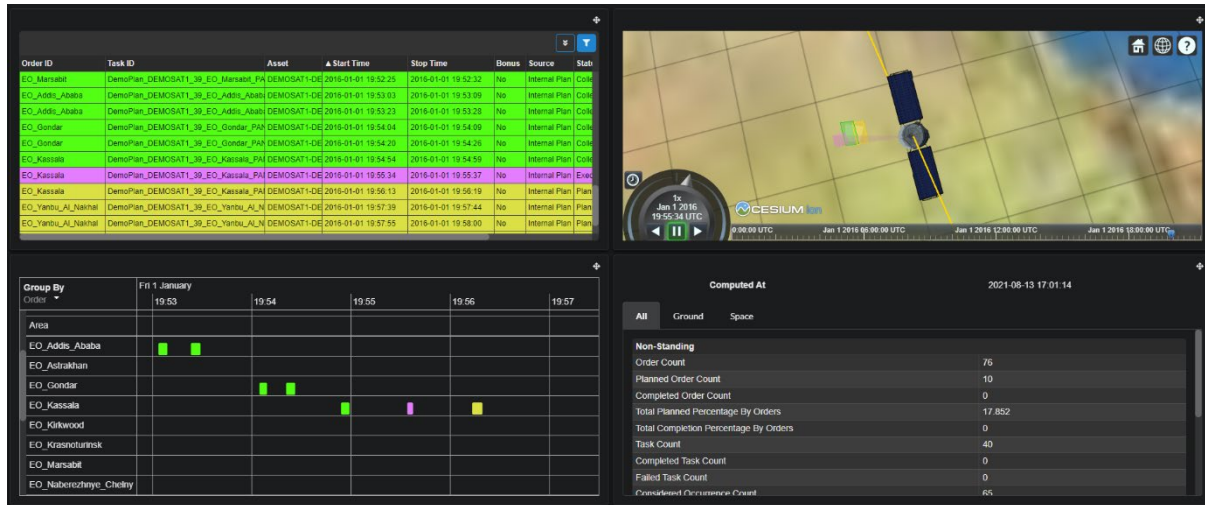

Figure 11.30: Orbit Logic CPAW dashboard. Credit: Orbit Logic.

### ACE CrtIPoint

The ACE CrtIPoint from Parsons (acquired Braxton Technologies January 2021) is an automated space vehicle and ground station command and control (C2) application with a plug-in architecture that provides nearly lights-out TT&C operations. ACE CrtIPoint includes the hardware and software components necessary for a satellite MOC. Key applications include: integration with antenna scheduling; ground station control and status; data forwarding for analysis; command plan execution; anomaly detection; and a turnkey TT&C system. COTS capabilities plug into standardized environments, allowing the product to be ready immediately within a range of mission architectures (50).

### Bright Ascension Mission Control Software

In addition to their tried and tested mission control software designed for easy-to-use monitoring and control during development and flight, Bright Ascension is currently developing an end-to-end suite of highly integrated software solutions for the entire mission from flight software development, testing and simulation, to ground operations and end user insights and analytics. As part of the suite, the company will offer two new products for mission operations – Groundkit, which provides reusable components and services for assembling complete and bespoke ground software systems, and Ops, a suite of applications for mission operations designed to reduce the complexity and cost of operations. The early versions of both products are expected to be released in the first months of 2025.

### Yamcs

Yamcs is a mission control software developed by Space Applications Services that is publicly



available under the GNU Affero GPL license. It is designed for the command and control of the spacecraft, payload, ground station, and ground equipment, and supports telemetry reception, archiving, telecommand sending, alarm generation, and replay processing. Yamcs features a comprehensive web interface. The backend can be extended or customized using Java (though some plugins are only available to customers) and can be deployed in the cloud or on-premises. The platform also supports industry standards like Consultative Committee for Space Data Systems (CCSDS), CCSDS File Delivery Protocol (CFDP), CubeSat Space Protocol (CSP) and XML Telemetric and Command Exchange (XTCE). The extensive API includes both REST and WebSocket. A desktop tool is available for authoring operator displays. Plugins for popular open-source visualization frameworks, such as Grafana and OpenMCT, are also available. A companion tool, the Yamcs Gateway, enables the development of Electrical Ground Support Equipment (EGSE) for spacecraft and payload development, supporting low-level interfaces like CAN-bus, MIL-1553, SpaceWire and RS422. Figure 11.30 is a screenshot of the web GUI.

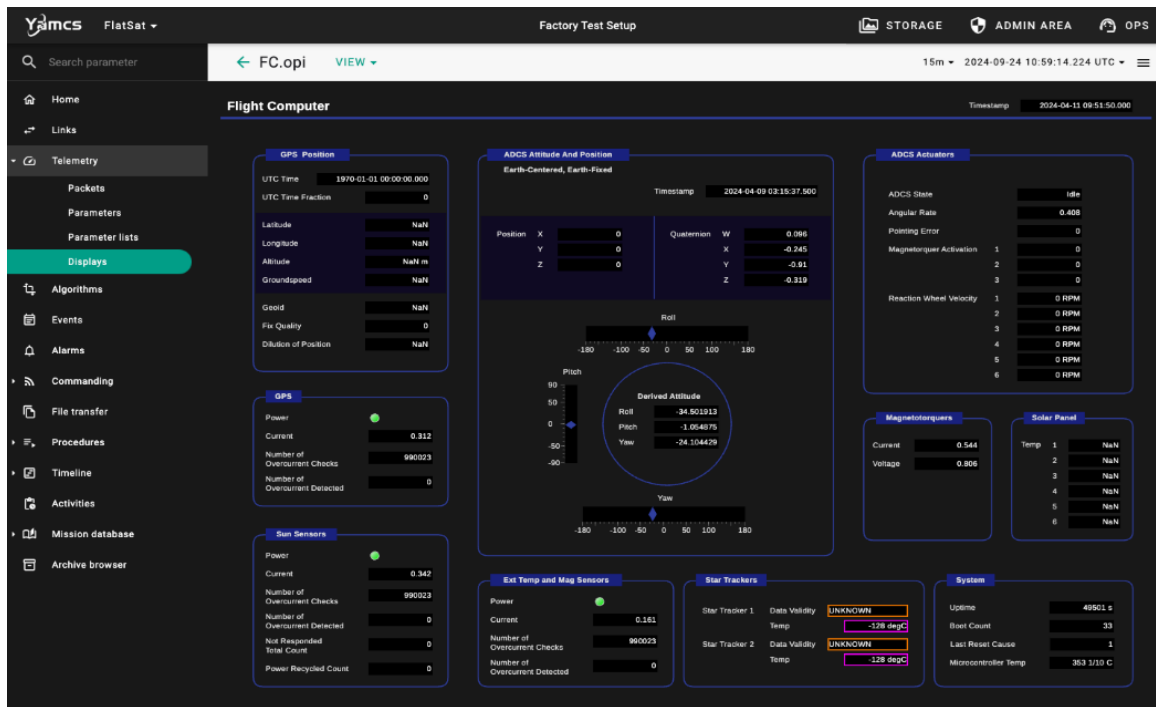

Figure 11.30: Screenshot of Yamcs web GUI. Credit: Yamcs.

## 11.10 On the Horizon

Ground data systems must continue to evolve to keep up with the furious pace of small satellite technology. Advancements in onboard processing and data storage will demand more capability in getting data to the ground. Mass production of small satellites is quickly becoming a reality and large constellations are now starting to find their way to orbit. This will require ground system technology that can communicate with multiple satellites simultaneously. Free Space Optical communications and phased array ground systems are emerging solutions to these needs. While both technologies have seen years of investment, they are now just starting to find their way into the ground networks. While it may still be years before becoming a staple for these networks, the following sections provide insight to the state of these technologies and where they are headed in the future.

### 11.10.1 Free Space Optical Communications



Increasing demand for data from NASA missions has led to a migration over the past few decades to increasingly higher RF bands (X, K, and Ka) and ultimately to the optical and near-infrared regime. Free Space Optical (FSO) communications are expected to increase data rates by two orders of magnitude over traditional RF links (see Communications chapter for more on FSO communications). The next generation systems will incorporate optical communications, and several early flight demonstrations and uses of optical communications in the coming decade are expected to be transformational for NASA and other space organizations. Whereas Ka-band frequencies go up to 40 GHz frequency, the optical signal reaches up to 200,000 GHz. Higher frequencies have the potential for huge increases in data rates, theoretically proportional to frequency-squared if all other factors are equal. At optical wavelengths, other factors, such as atmospheric losses, receiver sensitivity, aperture, and power, must also be considered, but nonetheless, optical communications offer the potential for orders of magnitude improvement in data throughput.

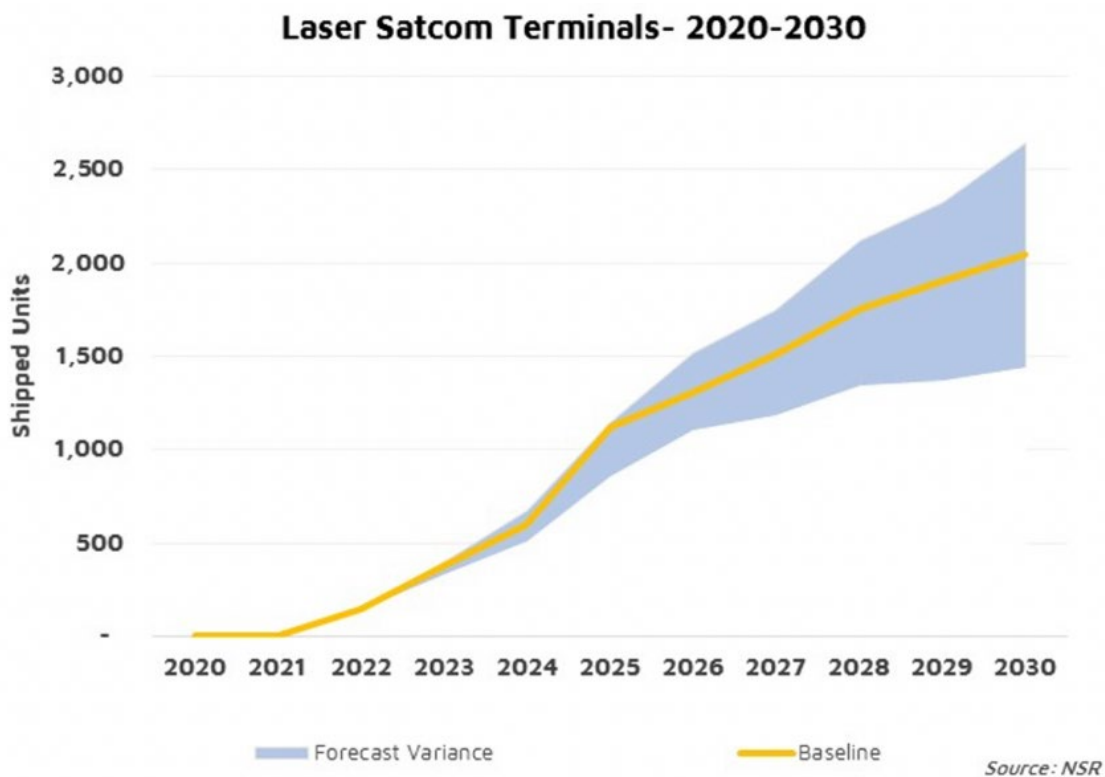

*Figure 11.31: Laser terminals future forecast. Credit: Northern Sky Research.*

For space applications, lasers are being used as the light source. Laser systems with dynamic systems such as fast-steering mirrors are used to accurately point the laser on the spacecraft to the ground terminal. Other methods using laser arrays for beam pointing are also being developed to reduce the need for complex dynamic systems. Data is transmitted in the form of hundreds of millions of short pulses of laser light every second. The light is made of photons and the optical ground terminals are setup to collect the light at the photon level. In fact, the ground terminals are designed for an environment where relatively few photons may be received from the transmitter spacecraft, especially from deep space. Direct photon detection with Pulse Position Modulation (PPM) is used instead of the common RF technique of direct carrier coherent modulation to convey information. PPM modulation uses a time interval that is divided into a number of possible pulse locations, but only a single pulse is placed in one of the possible positions, determined by the



information being transmitted. To detect extremely faint optical signals with relatively few photons through the atmosphere, optical ground stations can use a superconducting nanowire single photon detector (SNSPD), which, to increase the sensitivity of the nanowires, uses a 1-Kelvin cryocooler. A real-time signal processing receiver uses time-stamped photon arrivals to synchronize, demodulate, decode, and de-interleave signals to extract information code-words. Hence, while the specific technologies employed differ in some respects from those used in radio frequency ground terminals, the higher-level functions performed by the optical communication ground terminal are similar.

Optical communication is attractive for mission designers using small, resource-constrained spacecraft, because it offers a path to relatively high data rates with relatively small, low-power spacecraft equipment. The same volume and power savings can be experienced on the ground terminal side as well. This is driven by the size of the wavelengths. Because RF wavelengths are longer, the size of their transmission beam covers a wider area, therefore, the capture antennas for RF data transmissions must be very large. Laser wavelengths are 10,000 times shorter, allowing data to be transmitted across narrower, tighter beams. This results in the ability to deliver the same amount of signal power to much smaller collecting areas. The reduction in antenna size applies for ground and space receivers, which allows for size and mass reductions on the spacecraft side.

NASA made great strides with its optical communication demonstration on the Lunar Atmosphere and Dust Experiment Explorer (LADEE) mission. The pivotal NASA Lunar Laser Communications Demonstration (LLCD) was able to achieve 622 Mbps from a lunar distance. NASA has several exciting optical communications demonstrations, including O2O, Illuma-T, T-Bird and the Laser Communications Relay Demonstration (LCRD). LCRD is supported by Optical Ground Station (OGS)-1 at OCTL, and OGS2 in Hawaii (51).

Northern Sky Research (NSR) predicts growth for optical communications, which needs to be matched by OGS (Figure 11.31). “The demand now is not for just one gigabit per second, not 10 gigabits per second, but tens if not hundreds of gigabits per second. And it’s growing exponentially. The only way to achieve that is by starting to use optical communications or laser communications to augment or to complement RF communications” (Barry Matsumori, CEO of BridgeComm, 2022) (52).

### **11.10.2 Optical Ground Stations and Future Infrastructure Requirements**

OGS contain notably different equipment than RF stations, including an optics assembly, photon counter assembly (usually involving a photon counting nanowire detector and cryostat), and signal processing assembly with a time-to-digital converter. Since optical communications use a frequency higher than RF, (e.g., 1,550 nm downlink and 1,065 nm uplink wavelengths), the optical dishes can be smaller than RF antennas. To receive optical signals from a low-Earth orbit, 40 – 60 cm telescopes are sufficient. For successful deep space optical communications, calculations show that 3 m, 4 m, or even 8 m diameter ground apertures are required, depending on the distance from Earth. For these size apertures, when a 3 – 8 m OGS is not available, partnerships can be formed with large astronomy telescopes. For example, JPL-designed OGS equipment has been integrated at the Palomar Observatory (Hale 5-m telescope) for future use by the Deep Space Optical Communications (DSOC) demonstration. Note that OGS for LEO and deep space need different types of modems. It is also important for OGS to have spatial diversity. Weather,



atmospheric conditions, turbulence, and aerosols in the air can degrade laser propagation. Because certain types and depth of cloud covers can cause signal loss, probability of link success increases with multiple diverse locations.

For interoperability between SmallSats and public and private optical ground stations, a common communications standard is key. The Consultative Committee for Space Data Systems (CCSDS) and Space Development Agency (SDA) provide recommendations for communications standards, including optical communications. Adhering to these standards by both SmallSats and ground stations allows for multi-mission optical ground stations.

JPL is operating the Optical Communications Telescope Laboratory (OCTL) at Table Mountain, CA, with a 1 m telescope, as shown in Figure 11.32. This dish was used for the LADEE mission and offered great performance from a lunar distance (53).

JPL most notably operates the Deep Space Network (DSN), supporting 2-way RF communications and ranging services. Given the existing infrastructure, it is advantageous to augment a DSN RF antenna by installing optical segments at its center, making it a dual-purpose, RF-Optical hybrid antenna. The installation is being implemented in two phases.

In 2022 a small prototype RF-Optical system, including the mirror, cameras, and backend has been installed into DSS-13 (Figure 11.33) at the Goldstone Deep Space Communications Complex. DSS-13 is the R&D 34 m BWG antenna at Goldstone. The combination of seven small (0.5m) mirrors comprises a synthesized prototype optical aperture of about 1.3 m diameter. As of 2022, the seven-segment prototype mirror system has been undergoing alignment, test, and checkout. Control was verified to maintain segment position to <1 microradian, with first light successfully received from natural light sources. 1550 nm light was measured through the 100-meter fiber at the pedestal. JPL was able to track multiple sources across the sky from 20-80 degrees elevation.

A JPL designed communications detector and optical receiver been installed and tested over the air on DSS-13 as well. Other demo opportunities which could occur during the wait for Psyche (launch now delayed until next year) are being investigated.

The operational RF-Optical hybrid will ultimately



Figure 11.32: JPL's OCTL showing a 1-meter optical aperture. Credit: NASA JPL.

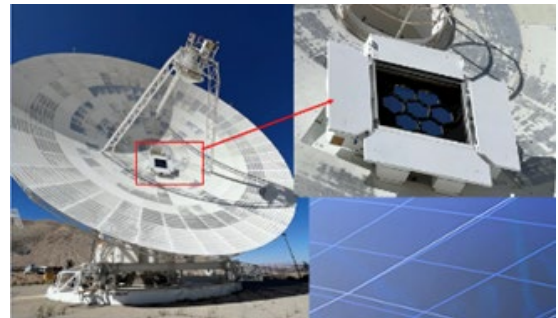

Figure 11.33: JPL's DSS-13, a 34m RF antenna, showing a 1.3-meter optical aperture in its center. Credit: NASA JPL.



Figure 11.34: Artist overlay of built DSN RF antenna and planned 8m optical segments at its center. Credit: NASA.





include 64 mirrors each of 1m diameter, installed as a segmented 8 m optical receive aperture/mirror physically inside one of the new DSN 34 m radio frequency ground terminals (DSS-23, in California). The final phase includes completion of the full 64- segment aperture on DSS-23, as illustrated in Figure 11.34, including a full year of field tests. This 8 m equivalent optical ground aperture will be operational in the early 2030s.

DSS-23 will be capable of a full set of RF services with the 34 m antenna in addition to high-rate optical communications with its 8 m optical assembly. Before the full operational readiness dates for optical communications, the 1.3 m partial optical systems will be usable at various times for best effort demonstration optical communications passes in the near-Earth or Lunar regimes, as well as for deep space missions.

The DSS-23 optical receiver is the same design that JPL is delivering to the Palomar Observatory for use with the DSOC optical communications technology demonstration on the NASA Psyche mission. This receiver is also being installed in ground terminals at White Sands and other locations for other near- and deep-space missions, as well as Artemis. One exciting implication of this 8m equivalent optical aperture is that it meets the 230 Mbps downlink data rate requirement for human exploration of Mars.

Looking at the broader optical communications landscape, over the past decade the community has been confronted with a chicken and egg problem: due to the lack of a ground segment, the FSO space segment has been slow to develop, and additional investments have not been made due to the low number of satellites flying an FSO ground segment. Further, due to the experimental nature of the first flying optical payloads, there has not been sufficient operational budget to pay for optical ground station services. Nevertheless, optical downlinks have the potential to become an essential part of data downlinks, especially in the new-space domain (54).

## Europe

The European Optical Nucleus Network was formed between ESA ESOC, Germany Aerospace Centre (DLR), Global Security Operations Center (GSOC) and KSAT. Parties agreed to have an interoperable multi-mission approach based on the Consultative Committee for Space Data Systems (CCSDS) standards. Starting locations and characteristics are summarized in Table 11-17. The Nemea OGS (Figure 11.35) was operational as of 2022 after initial investments in the first commercial OGS, with the other stations soon to follow. The goal is to bring all building blocks together into an automated, cost-efficient, operational, multi-mission optical ground station service. This groundbreaking OGS uses modified COTS components to reduce cost, and could also be a blueprint for future stations. KSAT co-located its first OGS with KSAT RF antennas in the mid-latitudes at Nemea, due to the temperate weather and sharing the existing infrastructure. The OGS is compliant to the Optical On-Off Keying (CCSDS 141b1) draft standard and is designed to be cost competitive to the KSAT<sup>LITE</sup> service which KSAT is currently offering in the RF domain. The telescope is mounted >3 m above the ground to avoid ground layer turbulence. The dome is a one-part, completely retractable structure with UV resistant plastic fabric. It is not connected to the telescope foundation to avoid coupling of vibrations caused by wind to the telescope system.



*Figure 11.35: KSAT's low-complexity optical ground station in Nemea (2021).*



	<b>Nemea</b>	<b>Almeria</b>	<b>Tenerife</b>
<b>Downlink wavelength support range</b>	1529-1569nm	1529-1569nm	1529.5-1568 nm
<b>Telescope main aperture diameter</b>	50 cm	60 cm	80 cm
<b>Elevation angle support range</b>	20° to 90°	10° to 85°	10° to 87° (LEO) 10° to 89° (GEO)
<b>Max. operation wind speed</b>	15 m/s (18 m/s gust)	15 m/s (18 m/s gust)	14m/s
<b>Operational min. sun-distance</b>	20°	20°	TBC
<b>Tracking modes</b>	Program-track Auto-track	Program-track Auto-track	Program-track Auto-track
<b>Temperature operational range</b>	-15°C to 40°C	-5°C to 35°C	TBC
<b>Acquisition Beacon Source</b>	1589.3nm, 5W (peak)	1589 – 1591nm, 5W (peak) TBC	1591.26 nm, 5 W 1590.4 nm, 8 W
<b>Acquisition beacon divergence angle (1/e<sup>2</sup> full-angle)</b>	632 μrad	1000 μrad TBC	500 μrad
<b>FoV of auto-track system</b>	8.5x6.8 arcmin	15x12 arcmin TBC	8.6 arcmin (diameter)
<b>Absolute pointing error*</b>	< 5 arcsec	< 10 arcsec	< +- 103 arcsec (99% confidence)
<b>Auto-track accuracy</b>	1 arcsec RMS max. error 3 arcsec	1 arcsec RMS	0.41 arcsec RMS
<b>Site (mean) clear-sky probability</b>	Summer: 80-95% Winter <60%	Summer: >75% Winter: >55%	81%
<b>Site long term average seeing</b>	Day: 2.7 arcsec Night: 3.6 arcsec	TBD	Day: 2.2 arcsec Night: 1.8 arcsec
<b>Site WAN connectivity</b>	10 Gbps	10 Gbps	10 Gbps
<b>Location coordinates</b>	Lat. 37°50'42.5"N Long. 22°37'24.0"E 278.7 m above sea level	Lat. 37°5'36.3"N Long. 2°21'31,1"W 498 m above sea level	Lat. 28°17'58.7"N Long 16°30'38.5"W 2382 m above sea level

- KSAT co-located its first OGS with KSAT RF antennas in the mid-latitudes at Nemea, due to the temperate weather and sharing the existing infrastructure,
- The OGS is compliant to the Optical On-Off Keying (CCSDS 141b1) draft standard and is designed to become cost competitive to the KSAT<sup>LITE</sup> service, which KSAT currently offers in the RF domain.
- The goal was to bring all building blocks together into an automated, cost-efficient, operational, multi-mission optical ground station service.
- For cost reduction modified COTS components have been selected.
- The telescope is mounted more than three meters above the ground to avoid ground layer

turbulence.

- The dome is a one-part completely retractable structure with UV resistant plastic fabric. It is not connected to the telescope foundation to avoid coupling of vibrations caused by wind to the telescope system.

The First Data Link Between Commercial Optical Terminals has been validated through a temporary Sony optical terminal placed on the ISS, with a channel data-rate of 150 Mbit/s with BER varying from  $1e-3$  and  $<1e-6$ .

### Japan

The National Institute of Information and Communications Technology (NICT) optical ground station in Japan also received transmission from the SOLISS system by Sony CSL installed on the Kibo's exposed facility on the ISS (55). In 2021 NICT also reported that the 1 m optical ground station in Koganei, Tokyo received via optical communication images taken by the satellite's camera the using the SOTA optical communications device mounted on a 50 kg class microsatellite.

### Germany

The DLR German Aerospace Center is another organization active in optical communications. About 25 km west of Munich, Germany is their Optical Ground Station Oberpfaffenhofen (OGS-OP) that houses a 40 cm Cassegrain telescope (56). The German Aerospace Center has also developed a transportable optical ground station (TOGS). It has a 60 cm deployable telescope in a Ritchey-Chretien-Cassegrain configuration with a focal ratio of  $f/2.5$ . The telescope is supported by an altazimuth mount on a structure with four adjustable legs for leveling the mount and compensating for rough terrain. It has been successfully used to track the OPALS instrument on the ISS and serves as the primary ground station for the OSIRIS payload on the BiROS satellite. The German Aerospace Center OGS-OP and TOGS are shown in Figure 11.36.



WORK

Figure 11.36: (left) OGS-OP and (right) TOGS. Credit: German Aerospace Center. <https://creativecommons.org/licenses/by/3.0/de/legalcode>.

Microwave is a system integrator and provider of satellite communication technologies and products. WORK Microwave supplies Optical Ground Stations (OGS) as a turn-key solution that can be customized upon mission request. WORK Microwave collaborated with KSAT and Astelco to establish the first commercial ground station for ESA at Nemea Greece, and will install a complete SDA standard compliant OGS for KSAT by the end of 2024. WORK Microwave manufactured the OGS with the Digital Optical Ground (DOG) station suite for system configuration, monitoring and control, and communication. Figure 11.37 shows the OGS DOG schematics, with telescope control from WORK Microwave's partners. The DOG Suite is a technology platform for further developments in optical communications across LEO, MEO and GEO orbits, as well as for upcoming lunar and deep space missions. More info on <https://work-microwave.com/digital-optical-groundstation/>.



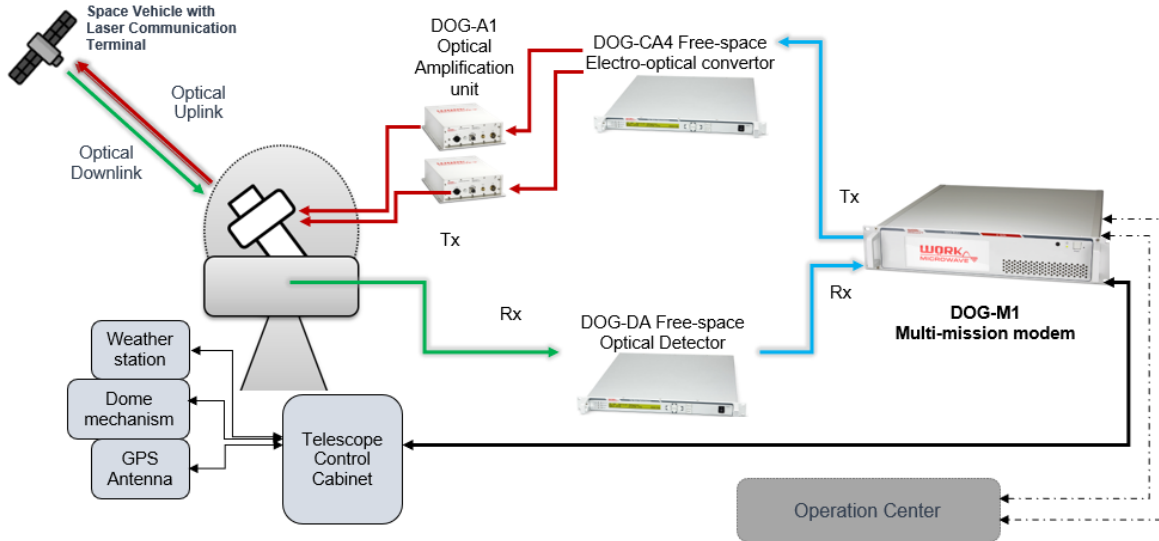

Figure 11.37: Schematics of the OGS with the Digital Optical Ground (DOG) station suite. Credit: WORK Microwave Inc.

### Australia – New Zealand

The Australian Optical Ground Station Network (AOGSN) will eventually be made up of four ground stations in Western Australia, South Australia, the Australian National University (Australian Capital Territory), and New Zealand. The plan is to tie these stations together to produce a communication network that can support optical, RF, and future quantum communications. In spring 2021, Thales Australia signed a research extension with SmartSat Cooperative Centre (CRC) for the development of advanced optical communications technologies (57).

Sascha Schediwy, head of the research group responsible for designing and building the WA Optical Ground Station (Figure 11.38), believes lasers will play a crucial role in the next human missions to the Moon. "It's likely to be how we'll see high-definition footage of the first woman to walk on the Moon," Dr Schediwy said (abc.net.au).

### United States

In the U.S. the Aerospace Corporation is a player in the Optical Communication arena. Their manned OGS 40 cm telescope, located in El Segundo, CA, demonstrated 200 Mbps from 725 km. It is operating at 1064 nm wavelength, thus it is not compatible with other optical ground stations or most COTS optical space terminals.

#### 11.10.3 Techniques to Improve Optical Comm Reliability

Laser communication is essential for future telecom networks to supplement RF communications and enable:



Figure 11.38: The 70 cm Western Australian Optical Ground Station (WAOGS) is installed on a rooftop at the University of Western Australia. Credit: The International Centre for Radio Astronomy Research.

- Very high throughput links (> 10 Gb/s and up to Tb/s)
- Communication without frequency band limitation
- Highly secure, stealthy, non-interceptable links

It is essential for operational use cases:

- Multispectral observation of Earth from space (very bandwidth intensive)
- Securing sovereign communication
- Telecommunication constellations that rely on very broad bandwidth links

### Cailabs

Cailabs designs and manufactures turnkey Optical Ground Stations for laser communication, offering unique turbulence mitigation based on its Multi-Plane Light Conversion (MPLC) technology, in both downlink (TILBA<sup>®</sup>-ATMO) and uplink (TILBA<sup>®</sup>-IBC). The company developed a standard design for 10 Gbps, LEO-to-ground, turbulence-proof laser comms, called TILBA<sup>®</sup>-OGS L10. The TILBA-ATMO is a product that takes a perturbed beam, corrects and couples it into a standard single-mode fiber. This compensates for atmospheric turbulence, improving free-space optical links. TILBA-ATMO makes it possible to use conventional telecom equipment and direct or coherent modulation formats to provide robust high-throughput links to optical ground stations. In an open-air trial with DLR, link stability with TILBA-ATMO was similar to that of the adaptive optics unit in low and medium turbulence, and more effective in strong scintillation

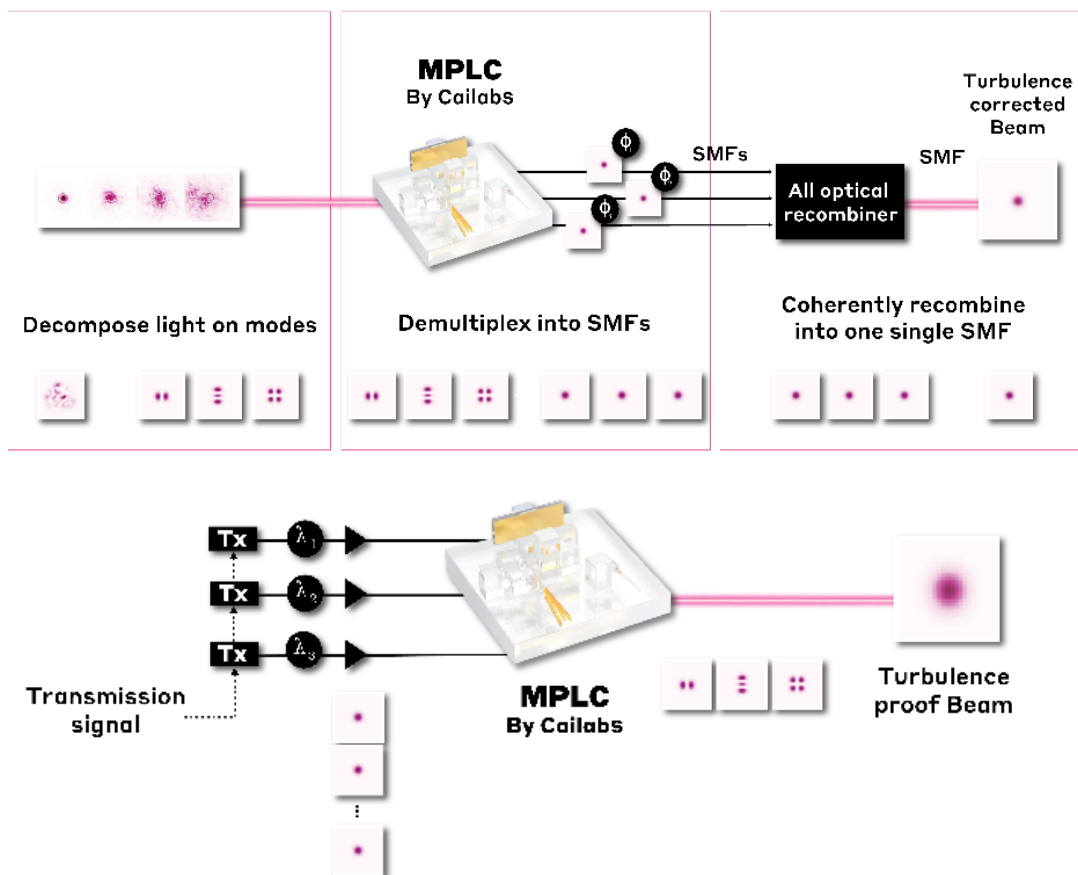

Figure 11.39: Cailabs Tilba Atmo equipment and schematic of TILBA-IBC. Credit: Cailabs.



conditions. They have also developed a second building block called TILBA-IBC, providing spatial diversity based on incoherent beam combination of spatial modes generated by the MPLC. This component can mitigate atmospheric turbulence in uplinks from ground to space, without the need to use multiple telescopes.

Cailabs is involved in multiple government and commercial OGS projects featuring 60 to 80 cm telescopes, compatible with both CCSDS and SDA standards, and is remotely operable (58). (<https://www.cailabs.com/en/>)

#### 11.10.4 Role of Optical Relays

Optical inter-satellite links are “critical to the success of the Space Development Agency’s low Earth orbit constellation” known as Transport Layer. SDA-Funded Laser Terminal Technology could connect to multiple satellites simultaneously. Each satellite in the Pentagon’s “planned mesh network of communications satellites could have as many as many as four laser links so they can talk to other satellites, airplanes, ships and ground stations.” BridgeComm, which recently received an SDA contract, “developed a so-called ‘one-to-many’ optical communications technology for point-to-multipoint transmissions” which could “help reduce the cost of building constellations by requiring fewer terminals,” Michael Abad-Santos, senior vice president of business development and strategy at BridgeComm] said. BridgeComm first demonstrated “point to multipoint optical communications in 2019 in a project with Boeing, and has since continued to mature the technology,” Abad-Santos said (59).

WarpSpace is a private Japanese company developing an inter-satellite communication system based on laser communication (Figure 11.40). The WarpHub InterSat link relays will enable low latency data delivery from MEO, and in the future it will connect to the Lunar Gateway or planetary deep space via optical communications (see <https://warpspace.jp/>).

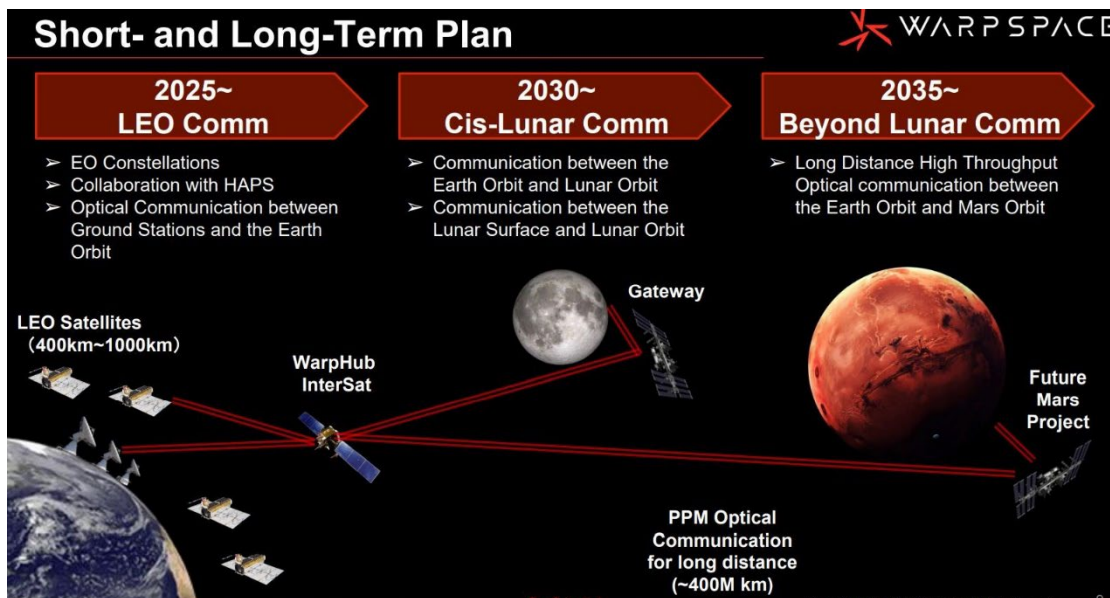

Figure 11.40: WarpSpace plans a satellite network in MEO orbit by 2025 with optical communications hardware able to be reached by any LEO satellite by 2025. Credit: WarpSpace.

### 11.11 Summary

The ground segment serves as the gateway to getting valuable data collected by the satellite into



the hands of the user. It is a critical component of the satellite system that requires attention at the earliest stages of mission planning. Understanding what ground solution best meets the needs of the mission has a direct impact on the spacecraft design, concept of operations, launch schedule, mission operations cost, and expected data volume for processing. Much effort also goes into preparing for the interaction between the satellite and ground network. Developing software and simulations, drafting operations manuals, conducting operations rehearsals, and performing compatibility tests are all par for the course. Post launch, the ground station also plays a key role in locating and commissioning the spacecraft.

In looking forward to the future of ground systems, the clear objective is how to bring the data down more efficiently. Great strides are being made with optical communications where it is possible to have increases in data per pass that are orders of magnitude above what can be achieved with RF communications. Optical communication technology is now being infused into ground system architectures, and flight hardware is becoming miniaturized enough to fit within small satellites. The ability of these systems to quickly change beam directions and acquire multiple targets will be critical for communicating with constellations of small satellites.

While the tried-and-true RF ground system solution remains the workhorse for small satellites, the innovative nature of the small satellite platform will soon challenge the community to adapt to systems capable of handling hundreds of satellites and high data volumes. Efforts are ongoing to keep pace, but only time will tell whether ground systems will advance or impede the small satellite revolution.

For feedback solicitation, please e-mail: [arc-sst-soa@mail.nasa.gov](mailto:arc-sst-soa@mail.nasa.gov). Please include a business e-mail so someone may contact you further.

## References

- (1) NASA. "NSN Brochure." 2021. Accessed July 2022. [Online] Available at: [https://explorers.larc.nasa.gov/2023APPROBE/pdf\\_files/Prog05e.%20NSN%20Brochure.pdf](https://explorers.larc.nasa.gov/2023APPROBE/pdf_files/Prog05e.%20NSN%20Brochure.pdf)
- (2) NASA. "Space Communications and Navigation." Accessed July 2022. [Online] 2021 Available at: [https://www.nasa.gov/directorates/heo/scan/services/networks/near\\_space\\_network](https://www.nasa.gov/directorates/heo/scan/services/networks/near_space_network)
- (3) KSAT, "KSATLITE." Accessed July 2022. [Online] Available at: <https://www.ksat.no/ground-network-services/ksatlite/>.
- (4) KSAT: Kongsberg Satellite Services. "Optical Communications: ESA-ESOC Optical Nucleus Network for Direct-to-Earth communications services up to Lunar distances." Accessed July 30, 2021. [Online] Available at: <https://www.ksat.no/ground-network-services/new-technologies/optical-comms/>
- (5) KSAT: Kongsberg Satellite Services. "KSAT has selected CPI Vertex to provide the 20m antennas that will support missions to the moon." July 4, 2023. [Online] Available at: <https://www.ksat.no/news/news-archive/2023/ksat-has-selected-cpi-vertex-to-provide-the-20m-antennas-that-will-support-missions-to-the-moon/>
- (6) Uppal, Rajesh. "Satellite Ground Segment as a Service (GSaaS) driven by New Space requirements." Accessed July 2022. [Online] Available at: <https://idstch.com/space/satellite-ground-segment-as-a-service-gsaas-driven-by-new-space-requirements/>
- (7) Nguyen, Louis. "Ground Stations as a Service (GSaaS) for Near Real-time Direct



- Broadcast Earth Science Satellite Data.” Accessed June 2021. [Online] Available at: [https://esto.nasa.gov/forums/estf2021/Presentations/June10/Nguyen\\_GSON\\_ESTF2021.pdf](https://esto.nasa.gov/forums/estf2021/Presentations/June10/Nguyen_GSON_ESTF2021.pdf)
- (8) Amazon. AWS Ground Station Features. AWS. 2020. Accessed 2022. [Online] Available at: <https://aws.amazon.com/ground-station/features/>.
  - (9) Viasat, “Real-time Earth Rethinking ground segment as a service” Accessed July 2022. [Online] Available at: <https://www.viasat.com/content/dam/us-site/antenna-systems/documents/viasat-real-time-earth-brochure.pdf>
  - (10) R. O’Dwyer. “Iridium 88kbps service commercially available.” November 11, 2021. Accessed July 2022. [Online] Available at: <https://smartmaritimenetwork.com/2021/11/11/iridium-88kbps-service-commercially-available/>
  - (11) D. Werner. “Analytical Space wins \$26.4 million to establish optical network.” February 10, 2021. Accessed July 2022. [Online] Available at: <https://spacenews.com/analytical-space-wins-26-4-million-to-establish-optical-network/>
  - (12) Safran Data Systems. “Cortex HDR, High Data Rate Receiver for Space Science and Earth Observation.” Accessed July 2022. [Online] Available at: [https://www.safran-group.com/sites/default/files/2021-05/col000016.4.0\\_cortex\\_hdr\\_a4\\_2.pdf](https://www.safran-group.com/sites/default/files/2021-05/col000016.4.0_cortex_hdr_a4_2.pdf)
  - (13) NI Ettus Research. “Products.” Accessed July 2022. [Online] Available at: <https://www.ettus.com/product-categories/usrp-x-series/>
  - (14) Kratos. “SpectralNet.” Accessed July 2022. [Online] Available at: <https://www.kratosdefense.com/products/space/networks/network-devices/spectralnet>
  - (15) Celestia STS. “TNO and Celestia STS sign agreement to commercialize Optical Modem.” June 30, 2021. Accessed July 18, 2021. [Online] Available at: <https://celestia-sts.com/2021/tno-and-celestia-sts-sign-agreement-to-commercialise-optical-modem/>
  - (16) Infinite Technologies Incorporated. “RADOMES FUNCTION” *Radomes & Composite Structures.* [Online] Accessed July 2022. Available at: <https://compositeradomes.com/radomes/what-is-a-radomes-function/>
  - (17) Amergint Technologies. “softFEP Datasheet.” Accessed July 2022. [Online] Available at: [https://www.amergint.com/wp-content/uploads/AMERGINT\\_Datasheet\\_Software\\_Front-End\\_Processor\\_V2-2.pdf](https://www.amergint.com/wp-content/uploads/AMERGINT_Datasheet_Software_Front-End_Processor_V2-2.pdf)
  - (18) Kratos. “quantumFEP Datasheet.” Accessed July 2022. [Online] Available at: <https://www.kratosdefense.com/-/media/k/pdf/s/sa/os-014-openspace-quantumfep.pdf>
  - (19) Csete, Alexandru. “About Gpredict.” October 2020. Accessed: July 2022. [Online] Available at: <http://gpredict.oz9aec.net/>
  - (20) GNU Radio. GNU Radio Main Page. Wikipedia. March 5, 2022. Accessed July 2022. [Online] Available at: [https://wiki.gnuradio.org/index.php/Main\\_Page](https://wiki.gnuradio.org/index.php/Main_Page)
  - (21) DeWitt, Henry. Satellite Ground Station Control. DeWitt & Associates. Accessed: July 2022. [Online] Available at: <http://www.dewitt-assoc.com/groundStation.html>
  - (22) GAUSS SRL “Group of Astrodynamics for the Use of Space Systems (G.A.U.S.S. Srl): Ground Station.” 2022. Accessed July 2022. [Online] Available at: <https://www.gaussteam.com/services/ground-station/>
  - (23) GUASS SRL. GAUSS UHF Mini Ground Dongle Datasheet. Accessed July 2022. [Online]



- Available at: [https://www.gaussteam.com/wordpress/wp-content/uploads/2018/04/GAUSSRadio\\_Miniground\\_Datasheet.pdf](https://www.gaussteam.com/wordpress/wp-content/uploads/2018/04/GAUSSRadio_Miniground_Datasheet.pdf)
- (24) GAUSS Srl. "Ground Station & Software." Accessed July 2022. [Online] Available at: [https://www.gaussteam.com/wordpress/wp-content/uploads/2018/01/Flyer\\_GroundStation\\_Software\\_1.pdf](https://www.gaussteam.com/wordpress/wp-content/uploads/2018/01/Flyer_GroundStation_Software_1.pdf)
- (25) Innovative Solutions in Space. "Ground Stations." Accessed July 2022. [Online] Available at: <https://www.isispace.nl/products/ground-stations/>
- (26) GomSpace. "Hands-off Operations Platform (HOOP)." Accessed October 2022. [Online] Available at: <https://gomspace.com/hoop.aspx>
- (27) Surrey Satellite Technology Ltd. "Space Services." Accessed July 2022. [Online] Available at: <https://www.sstl.co.uk/what-we-do/space-services>
- (28) Kratos. "Quantum Radio." Accessed July 2022. [Online] Available at: <https://www.kratosdefense.com/products/space/satellites/ttc-devices-and-software/quantumradio>
- (29) Kratos. "Be Future-Ready to Manage Tomorrow's Space Ground Network." Accessed July 2022. [Online] Available at: <https://www.kratosdefense.com/systems-and-platforms/space-systems/dynamic-ground/architecture>
- (30) INCOSE - International Council on Systems Engineering: "Systems Security Engineering: Mission and Objectives." Accessed July 12, 2021. [Online] Available at: <https://www.incose.org/incose-member-resources/working-groups/analytic/systems-security-engineering>
- (31) National Security and Defense: "Memorandum on Space Policy Directive-5—Cybersecurity Principles for Space Systems." September 4, 2020. Accessed July 12, 2021. [Online] Available at: <https://trumpwhitehouse.archives.gov/presidential-actions/memorandum-space-policy-directive-5-cybersecurity-principles-space-systems/>
- (32) NASA. "Space System Protection Standard" NASA-STD-1006 w/Change 1. October 29, 2019. Accessed July 12, 2021. [Online] Available at: <https://standards.nasa.gov/standard/nasa/nasa-std-1006-wchange-1>
- (33) NASA. "NASA's Commercial Communications Services." Accessed August 01, 2022. [Online] Available at: [https://www.nasa.gov/directorates/heo/scan/services/nasas\\_commercial\\_communications\\_services](https://www.nasa.gov/directorates/heo/scan/services/nasas_commercial_communications_services)
- (34) R. Ross, V. Pillitteri, R. Graubart, D. Bodeau, R. McQuaid, "Developing Cyber Resilient Systems: A Systems Security Engineering Approach." SP 800-160 Vol. 2. November 2019.
- (35) R. Ross, M. McEvelley, J. Oren, "Systems Security Engineering: Considerations for a Multidisciplinary Approach in the Engineering of Trustworthy Secure Systems." NIST SP 800-160 Vol. 1, November 2016 (Updated March 21, 2018). Accessed July 12, 2021. [Online] Available at: <https://csrc.nist.gov/publications/detail/sp/800-160/vol-1/final>
- (36) National Institute of Standards and Technology: "Cybersecurity Framework." Accessed July 12, 2021. [Online] Available at: <https://www.nist.gov/cyberframework>
- (37) The Aerospace Corporation: "Defending Spacecraft in the Cyber Domain." Accessed July 30, 2021. [Online] Available at: <https://aerospace.org/paper/defending-spacecraft-cyber-domain>



- (38) S. Visner and S. C. Kordella, The MITRE Corporation: “Cyber Best Practices for Small Satellites.” (November 2020). <https://www.mitre.org/publications/technical-papers/cyber-best-practices-for-small-satellites>
- (39) Consultative Committee for Space Data Systems: “Report Concerning Space Data System Standards.” CCSDS 350.7-G-2, Green Book, Issue 2. April 2019.
- (40) Consultative Committee for Space Data Systems: “Report on the Application of Security to CCSDS Protocols.” CCSDS 350.0-G-3, Green Book, Issue 3. March 2019.
- (41) G.P Bortoletto, D. Melli, F. Stigliano, D. Martin, F. Gardosi, “Maximize contact availability of smallsat clusters through MSPA technique on GSaaS.” Presented at SmallSat Conference, Logan, UT. 2021. Available at: <https://digitalcommons.usu.edu/smallsat/2021/all2021/44/>
- (42) Shannon Terry, A.I. Solutions, Inc. “What are Space Ground Systems?” Accessed July 2022. [Online] Available at: <https://ai-solutions.com/about-us/news-multimedia/what-are-space-ground-systems/>
- (43) R. Jewett, “Viasat Releases New Large-Aperture Space-to-Ground Communication Antennas,” ViaSatellite, January 20, 2022. Accessed July 2022. [Online] Available at: <https://www.satellitetoday.com/ground-systems/2022/01/20/viasat-releases-new-large-aperture-space-to-ground-communication-antennas/>
- (44) Sampathkumar, Arun Kumar. Uber-ization of Ground Stations. “The Small Satellite Market’s Enabling Aggregator Wave.” Accessed September 23, 2022. [Online] Available at: <https://interactive.satellitetoday.com/via/august-2021/uber-ization-of-ground-stations-the-small-satellite-markets-enabling-aggregator-wave/>
- (45) IO Spacecom. “Launching Go.BIC at SmallSat Conference 2024.” Press Release. August 5, 2024. [Online] Available at: <https://www.io-spacecom.com/news/highlights/io-spacecom-and-rbc-signals-launch-the-go-bic-service>
- (46) OpenC3, Inc. “Documentation.” Accessed 2022. [Online] Available at: <https://openc3.com/docs/v5/>
- (47) The Hammers Company. Galaxy. Accessed 2020. [Online] Available at <https://hammers.com/galaxy>
- (48) Xplore. Major Tom. Accessed July 2022. [Online] Available at: <https://www.xplore.com/services/operations-as-a-service/major-tom.html>
- (49) Orbit Logic. Accessed 2020. [Online] Available at: <https://www.orbitlogic.com/index.html>
- (50) Parsons, “Automated Command and Control for Smarter Space Operations.” Accessed 2022. [Online] Available at: <https://www.parsons.com/products/ace-ctrlpoint/>
- (51) NASA. July 15, 2018. “LLCD: 2013-2014.” Accessed 2022. [Online] Available at: <https://www.nasa.gov/directorates/heo/scan/opticalcommunications/llcd/>
- (52) Waterman, S. “Space Lasers Come of Age: Optical Communications for Satellites Are Ready for Prime Time.” February 22, 2022. Accessed July 2022. [Online] Available at: [https://interactive.satellitetoday.com/via/march-2022/space-lasers-come-of-age-optical-communications-for-satellites-are-ready-for-prime-time/\\_fragment.html](https://interactive.satellitetoday.com/via/march-2022/space-lasers-come-of-age-optical-communications-for-satellites-are-ready-for-prime-time/_fragment.html)
- (53) NASA. “Lunar Laser Communication Demonstration: NASA’s First Space Laser Communication System Demonstration Fact Sheet.” Accessed 2022. [Online] Available





- at: [https://www.nasa.gov/sites/default/files/lcdfactsheet.final\\_web.pdf](https://www.nasa.gov/sites/default/files/lcdfactsheet.final_web.pdf)
- (54) Krynitz, Martin and Heese, Clemens and Knopp, Marcus Thomas and Schulz, Klaus-Jürgen and Henniger, Hennes, "The European Optical Nucleus Network," 16th International Conference on Space Operations (SpaceOps 2021), 03.-05. May 2021.
  - (55) National Institute of Information and Communications Technology (NICT). "Small Optical Link for International Space Station (SOLISS) Succeeds in Bidirectional Laser Communication Between Space and Ground Station." April 30, 2020. Accessed 2022. [Online] Available at: <https://www.nict.go.jp/en/press/2020/04/30-1.html>
  - (56) Florian Moll, Amita Shrestha, Christian Fuchs, "Ground Stations for Aeronautical and Space Laser Communications at German Aerospace Center." Proc. SPIE 9647, Advanced Free-Space Optical Communication Techniques and Applications. <https://core.ac.uk/reader/31021696>
  - (57) Thales: "Beam me up! Thales & Goonhilly Earth Station Collaborate on Research into Laser Beams as Data Pipes." June 8, 2021. Accessed July 23, 2021. [Online] Available at: <https://www.thalesgroup.com/en/australia/press-release/beam-me-thales-goonhilly-earth-station-collaborate-research-laser-beams>
  - (58) Swedish Space Corporation. "SSC awarded 2.26M€ for NODES." Press Release. May 15, 2023. [Online] Available at: <https://sscspace.com/ssc-awarded-2-26me-for-nodes/>
  - (59) S. Erwin, "DoD Space Agency Funds Development of Laser Terminal that Connects to Multiple Satellites at Once." March 10, 2022. Accessed July 23, 2021. [Online] Available at: <https://spacenews.com/dod-space-agency-funds-development-of-laser-terminal-that-connects-to-multiple-satellite-at-once/>
  - (60) NASA. "NASA to Commercialize Near-Earth Communications Services." October 26, 2022. Accessed July 23, 2021. [Online] Available at: <https://www.nasa.gov/feature/Goddard/2020/nasa-to-commercialize-near-earth-communications-services>