



Jet Propulsion Laboratory
California Institute of Technology

In-space Assembly of Large Telescopes for Exoplanet Direct Imaging

Nick Siegler, Chief Technologist, NASA Exoplanet Exploration Program (JPL/Caltech)

Rudranarayan Mukherjee, Robotics Technologist (JPL/Caltech)

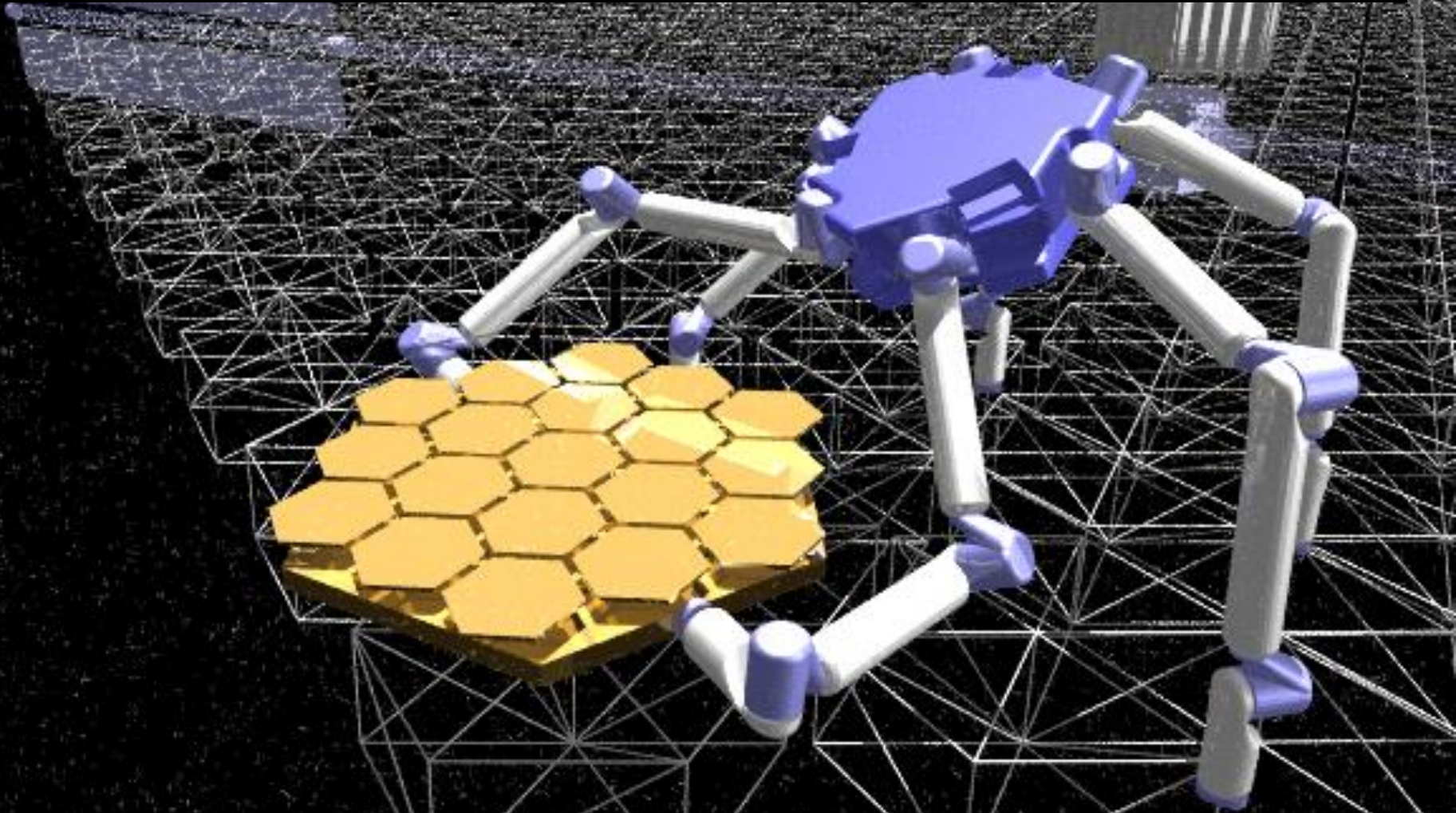

Aperture size limited by launch vehicle

Future science needs will require increasingly large telescopes

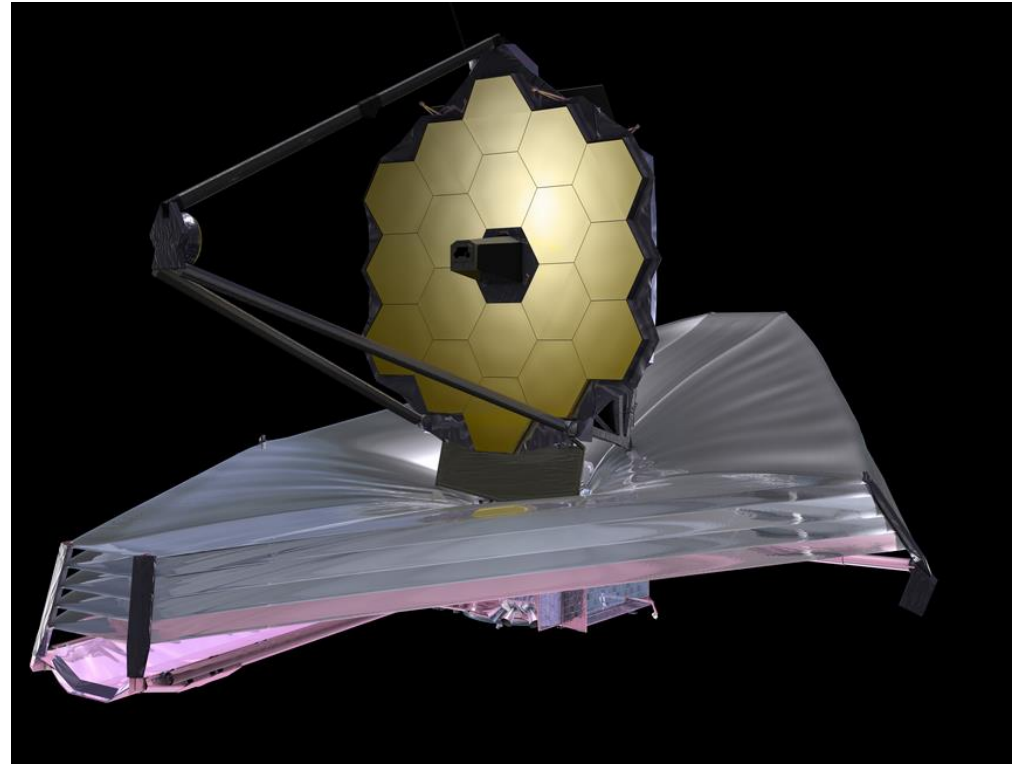

In-Space Large Aperture Telescope Assembly

Evolvable Space Telescope (NGAS)

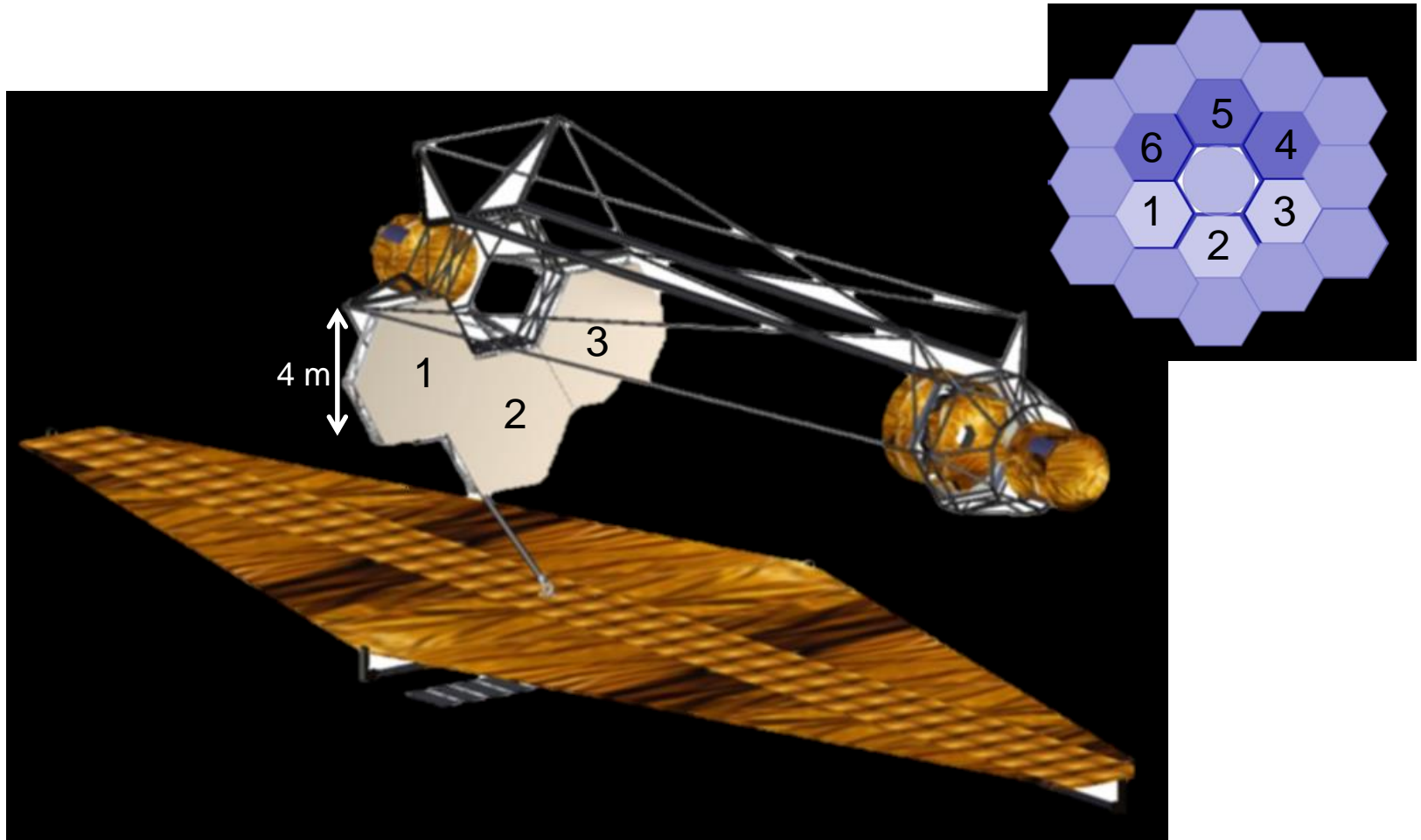

Polidan et al. 2016

In-Space Large Aperture Telescope Assembly

Using the Deep Space Gateway (cis-Lunar orbit) to assemble

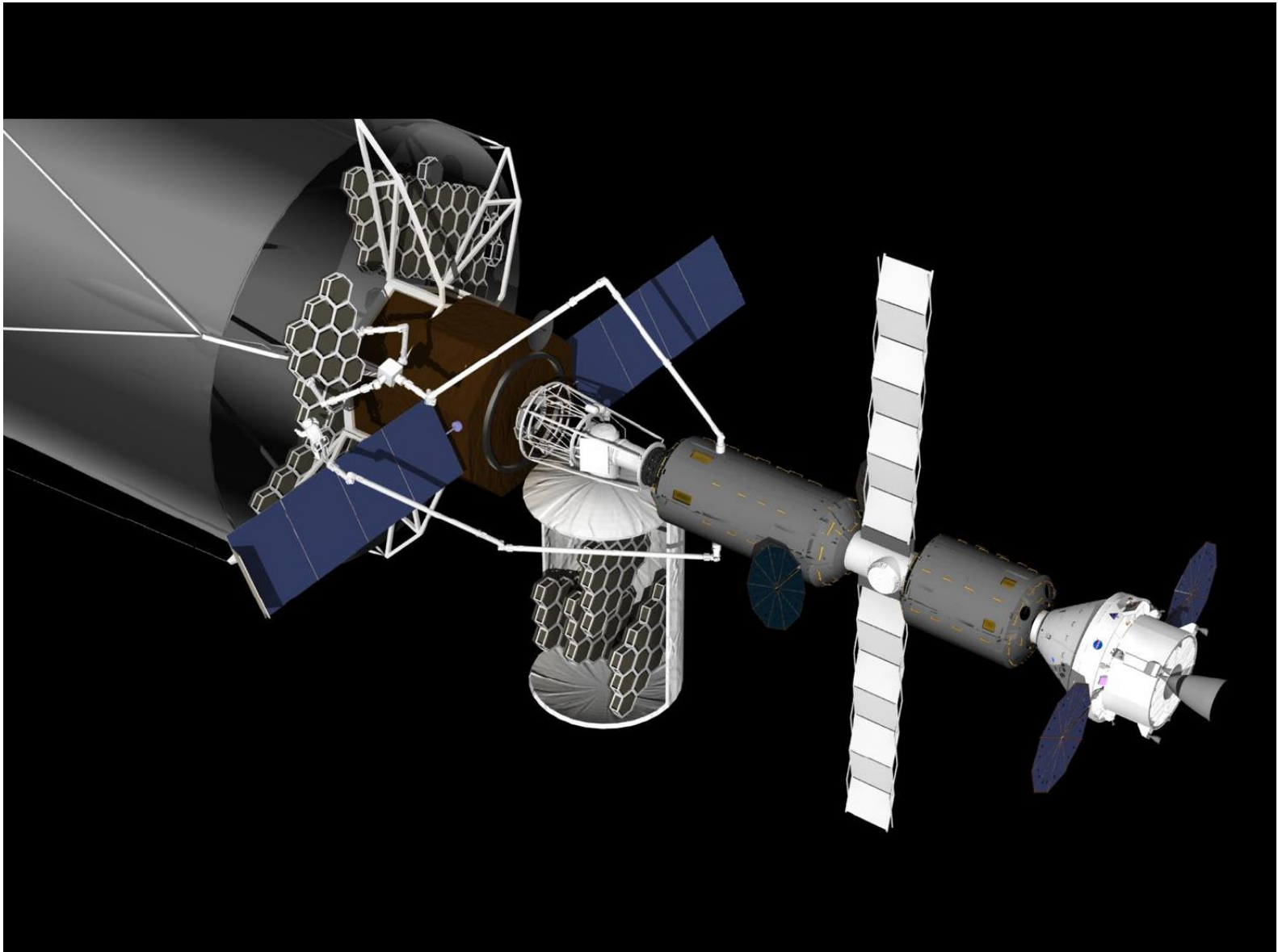

In-Space Large Aperture Telescope Upgrade

Telescope returns from ESL2 for servicing at EML1



Courtesy: Future In-Space Operations (FISO) working group (2007)

In-Space Large Aperture Telescope Assembly

Free-fliers (e.g. Orion) and assembly module docked to spacecraft bus

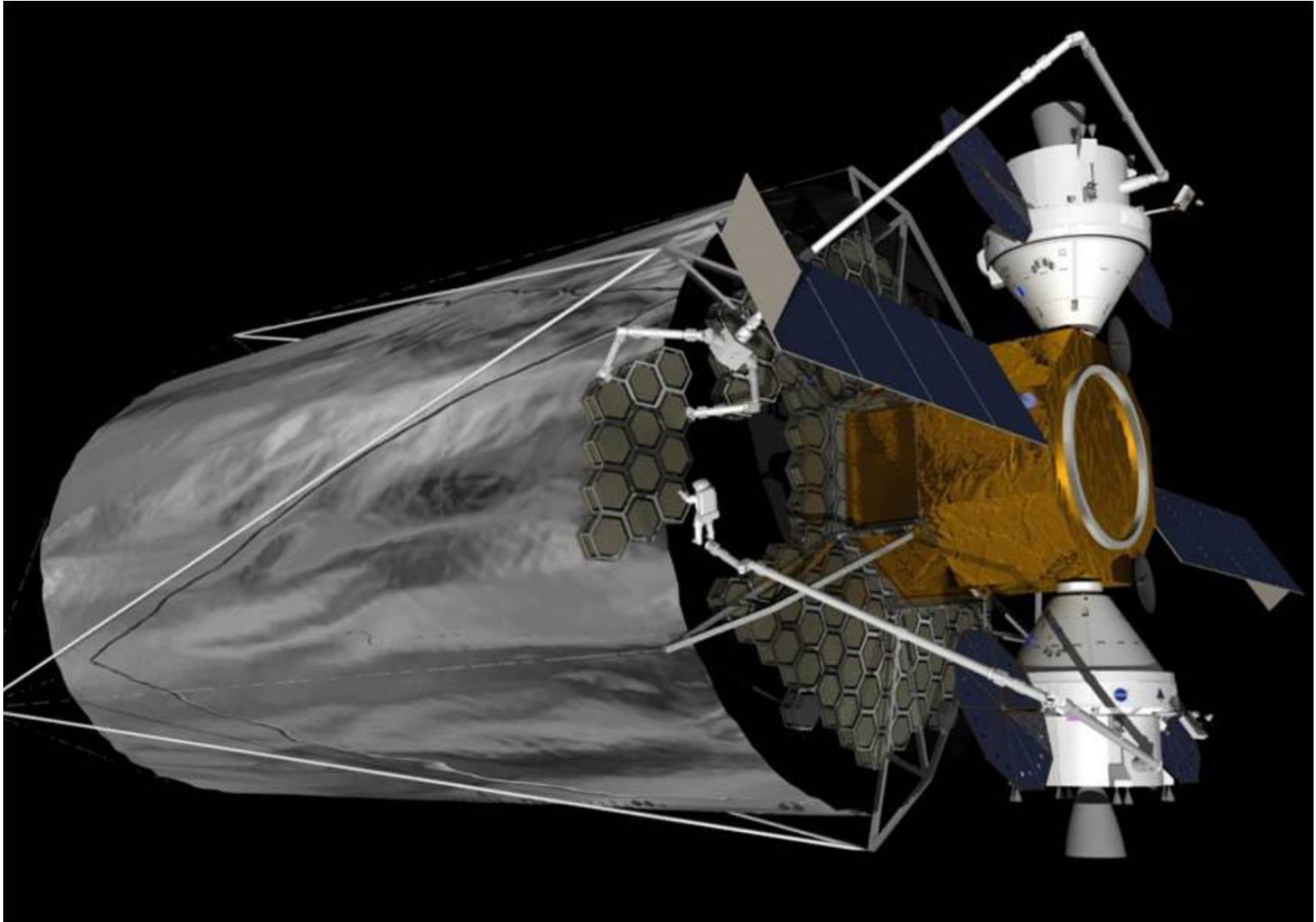

DARPA Orbital Express (2007)



- Multiple autonomous berthing and docking maneuvers

In-space firsts:

- Transfer of fuel
- Transfer of a battery through the use of 3-m long robotic arm

DARPA/Boeing/MDA/Ball Aerospace

Robotic Servicing Missions

DARPA Robotic Servicing of Geosynchronous Satellites (RSGS)

Privately
Developed
Spacecraft
(SSL)

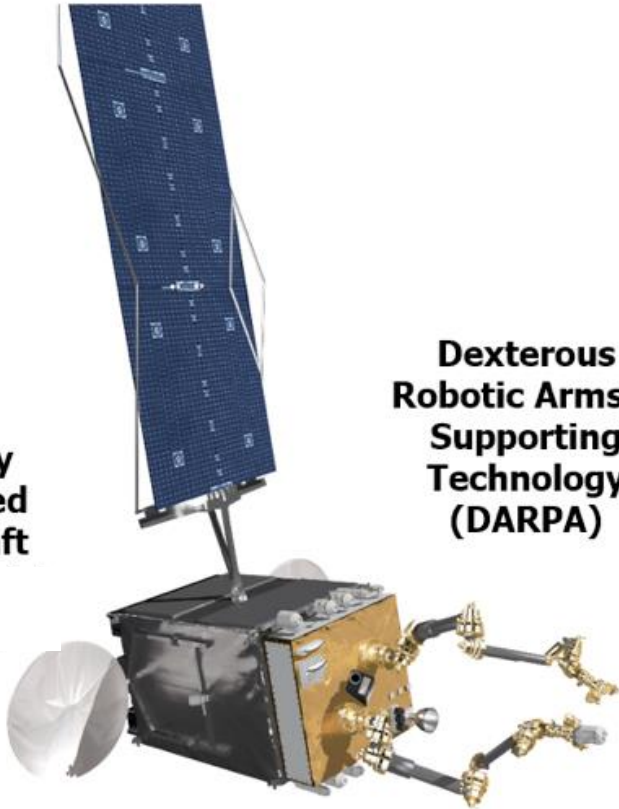

Dexterous
Robotic Arms &
Supporting
Technology
(DARPA)

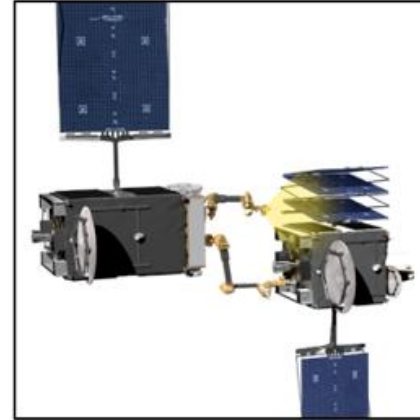

High-Resolution
Inspection



Anomaly Correction

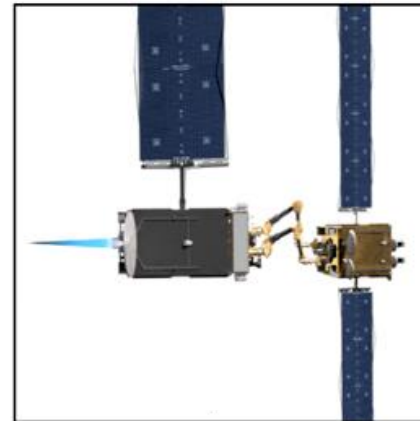

Cooperative Relocation

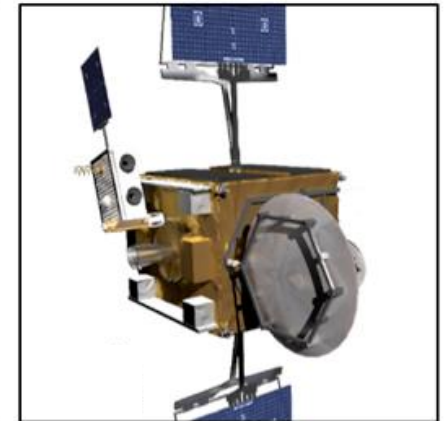

Upgrade Installation

Robotic Servicing Missions

Restore-L (NASA GSFC)

- **Refueling an existing satellite (Landsat 7)**
- **Future capability demonstrations:**
 - Observatory repair
 - Instrument replacement
 - On-orbit assembly and manufacturing

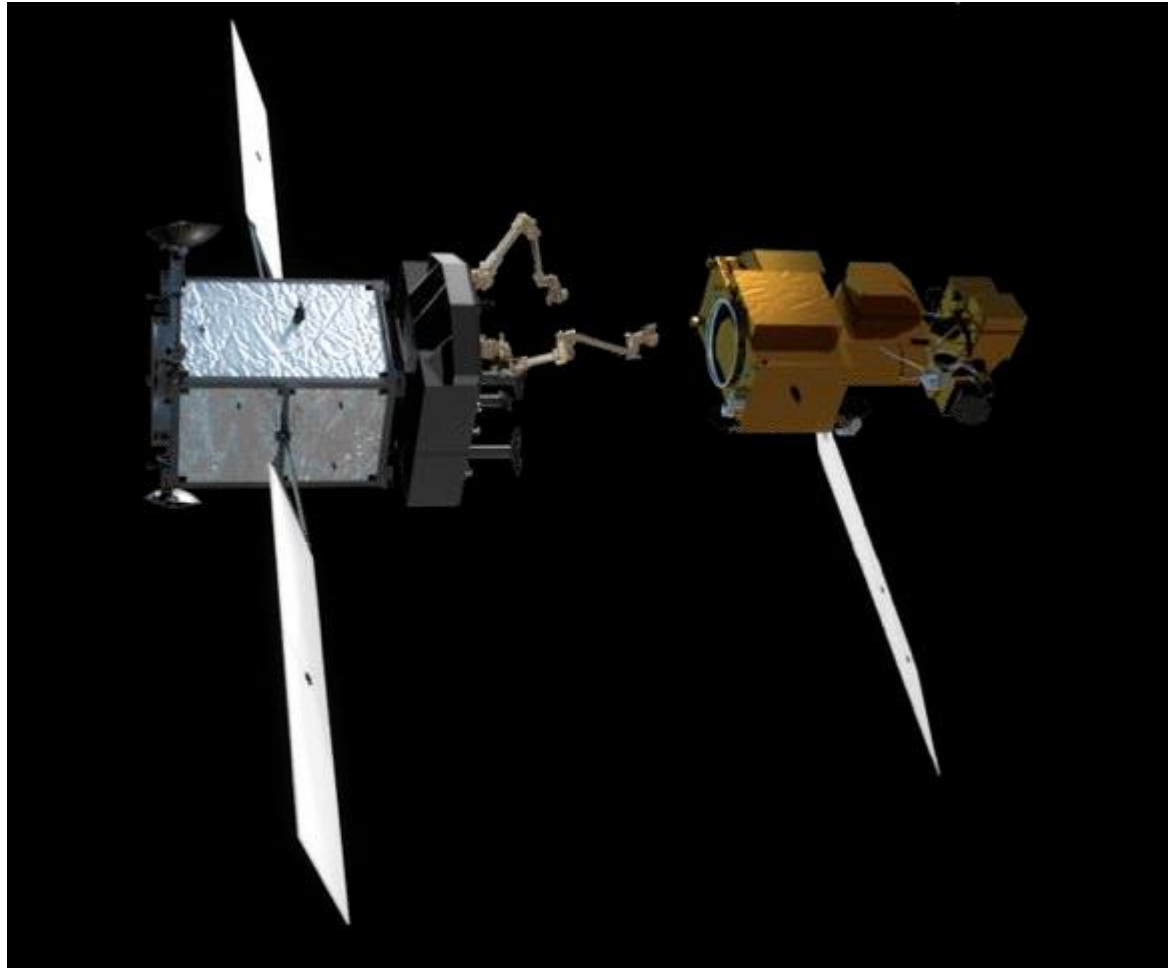

NASA GSFC

Beam Assembly Teleoperator (1983)

Neutral buoyancy robot (Space Systems Laboratory)



Accumulated a large database comparing human and robot performance in space

Demonstrated the ability of robots to assist astronauts during EVA excursions

ACCESS and EASE (1985)

Astronaut demo of large-structure piece-parts assembly



ACCESS (NASA LRC)



EASE (NASA MSFC and SSL)

ISS Robotic Systems

Canadarm (2001), Dextre (2008)

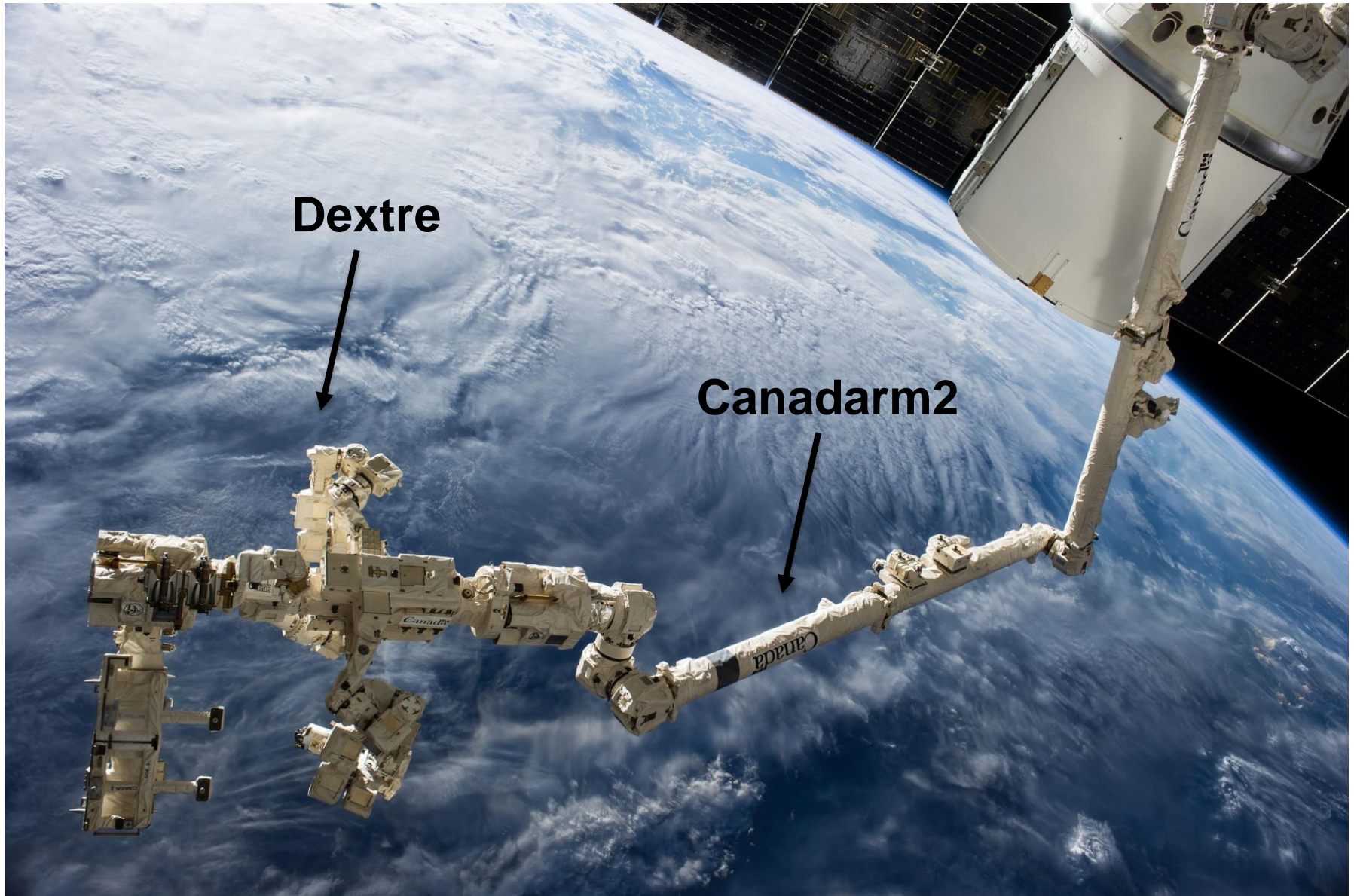

ISS Robotic Systems

Canadarm

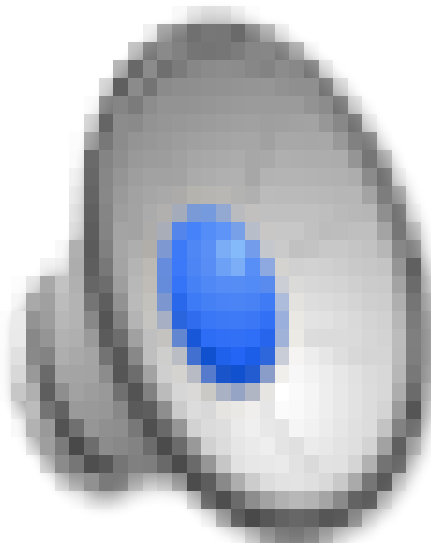

Optical Testbed & Integration on ISS eXperiment

In-space assembly demo of a segmented space telescope (2012)



- Intended to demonstrate assembly, alignment, calibration, and operation of future space observatories
- Robotically assembled and operated

Optical Testbed & Integration on ISS eXperiment

Robotically assembled and operated

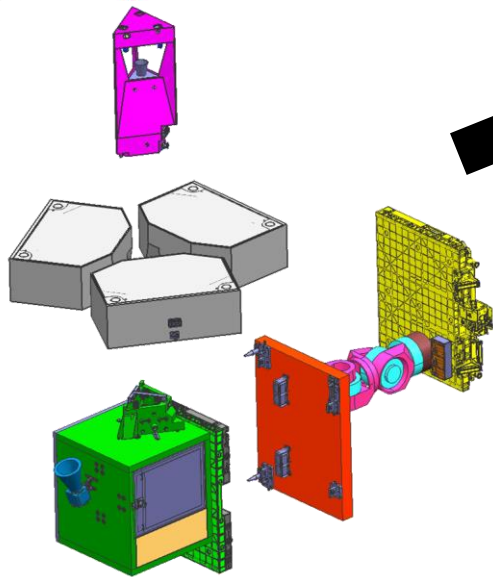

**6 launch modules
for assembly**

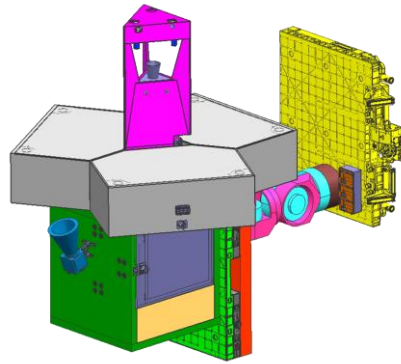
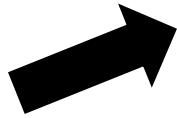

**Assembled
modules**

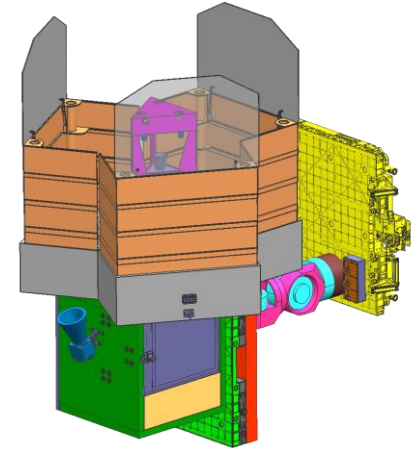
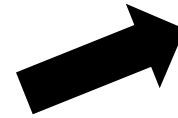

**Full deployment of
sunshades**

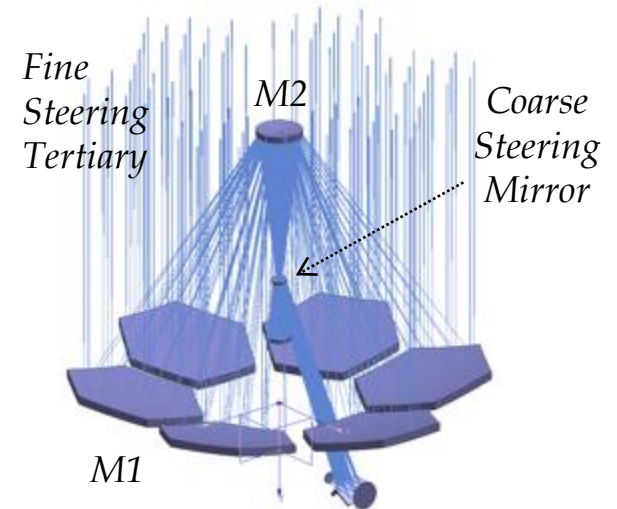

*3 Mirror Anastigmat Telescope
(1.45m aperture)*

Robotic Assembly of a Telescope

Modular deployable structure

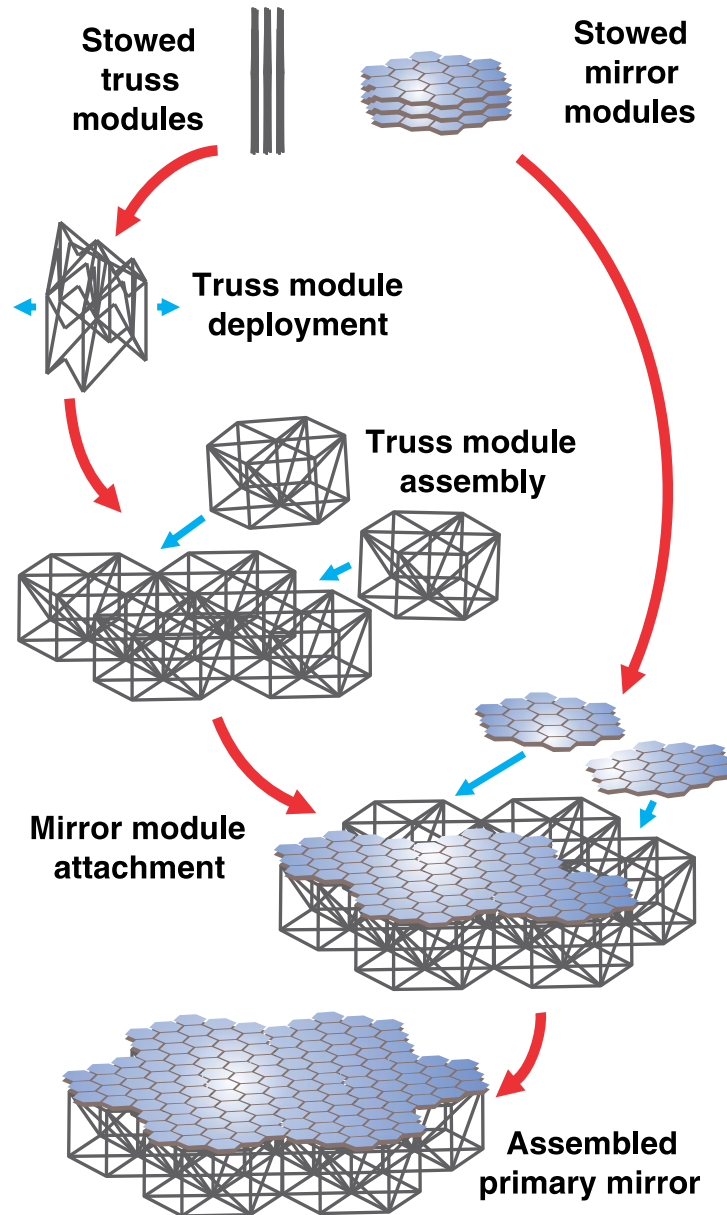

In Space Telescope Assembly Robotics

Multi-limbed robot

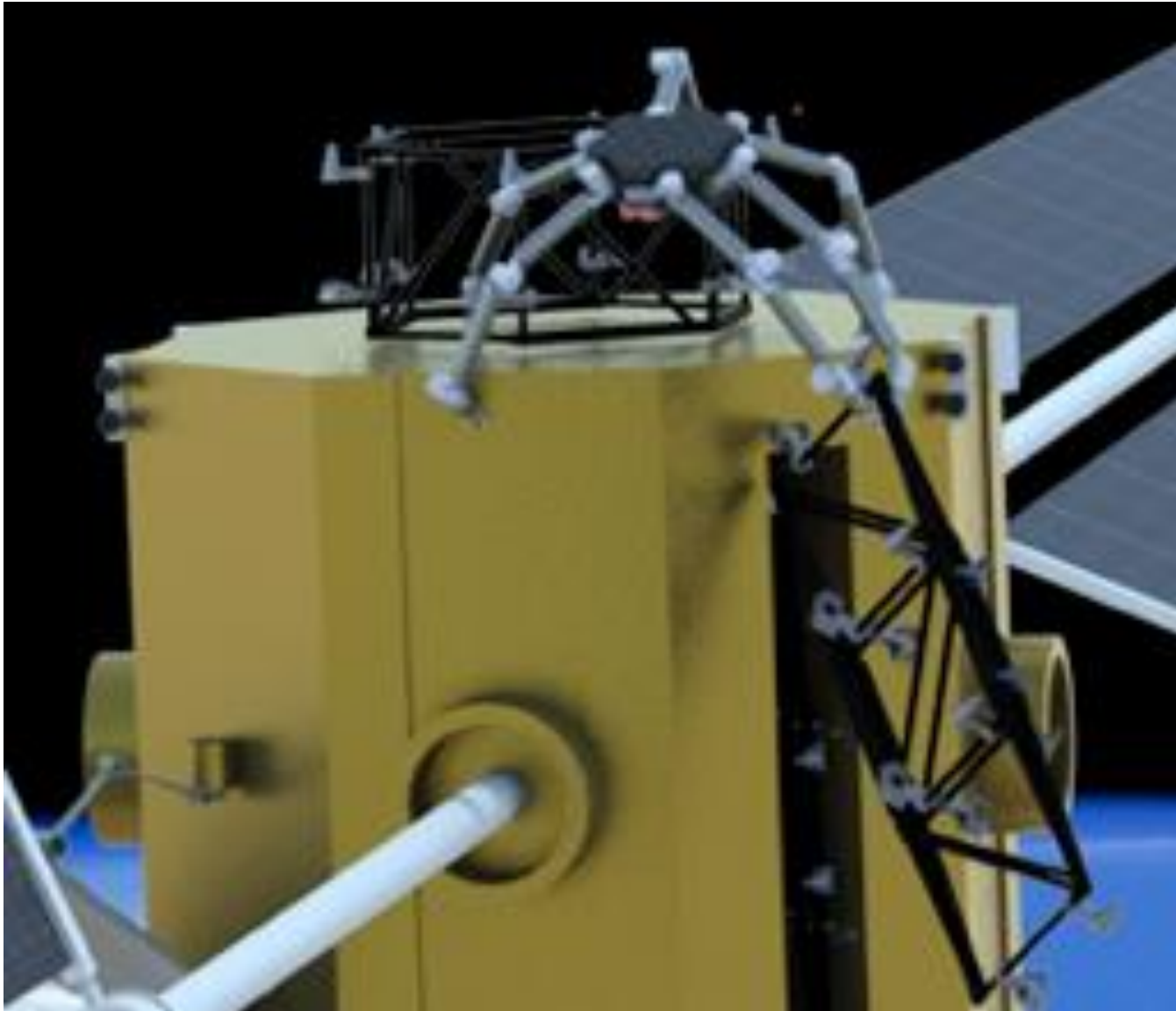

In Space Telescope Assembly Robotics

Multi-limbed robot

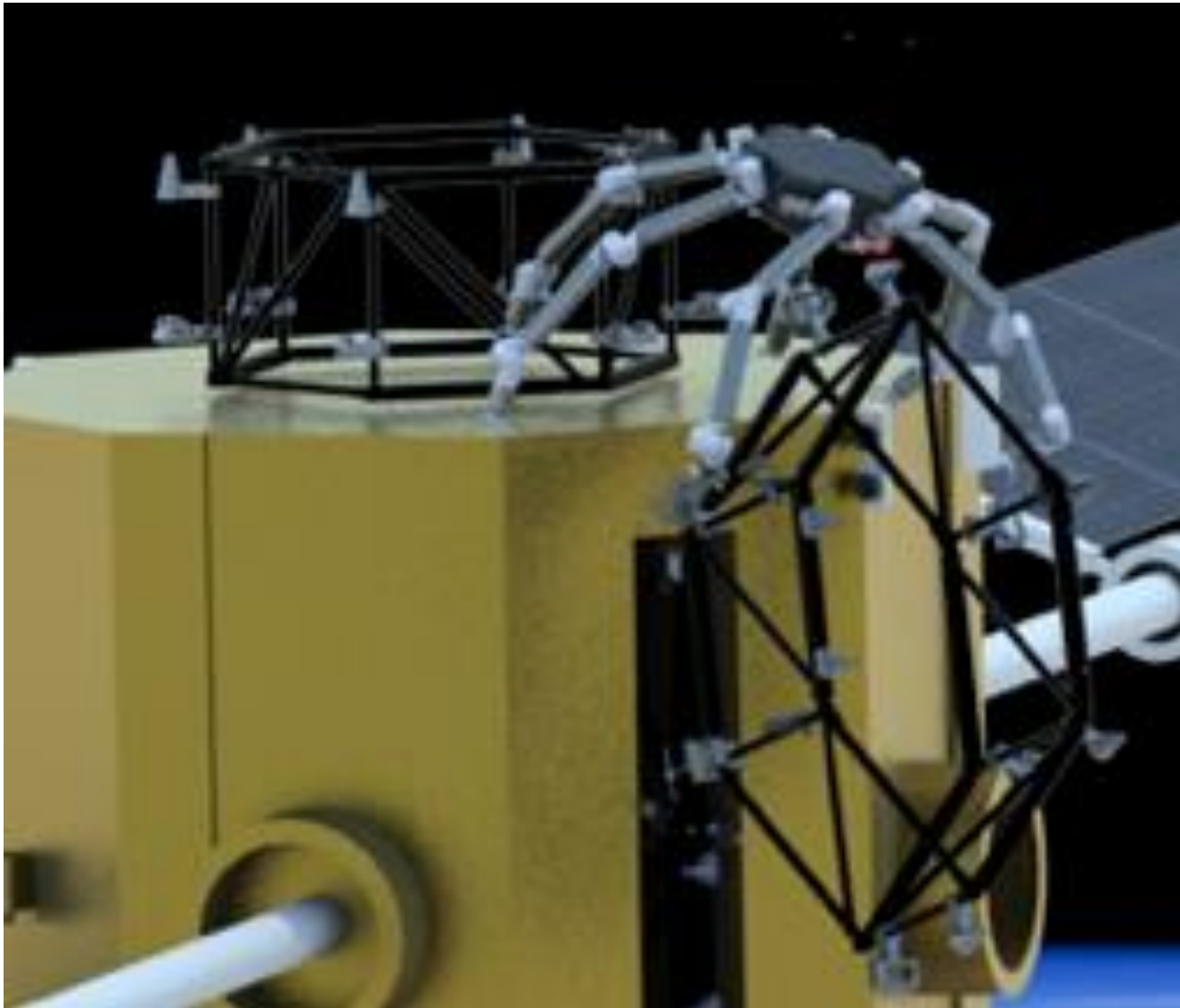

In Space Telescope Assembly Robotics

Multi-limbed robot

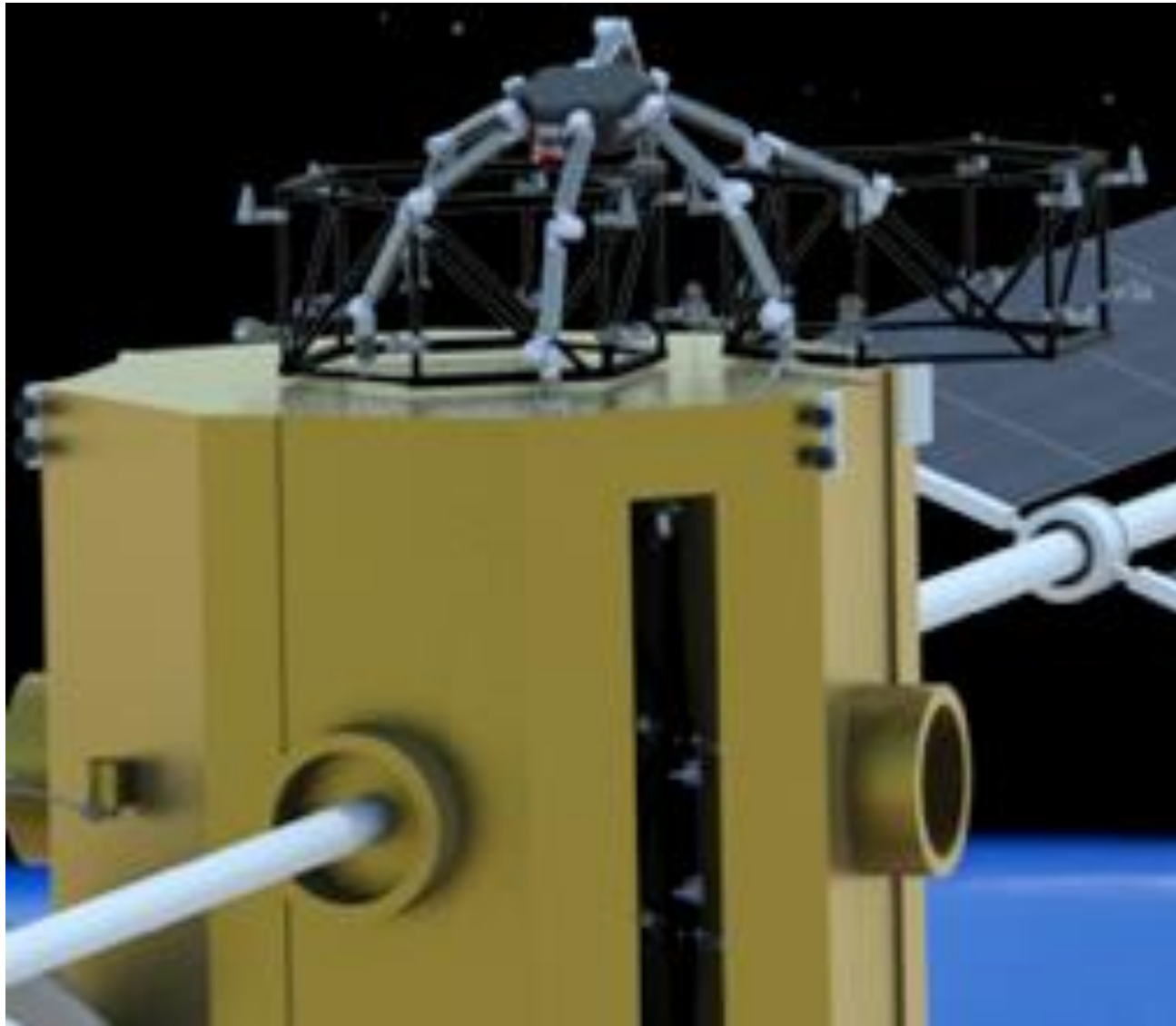

In Space Telescope Assembly Robotics

Multi-limbed robot

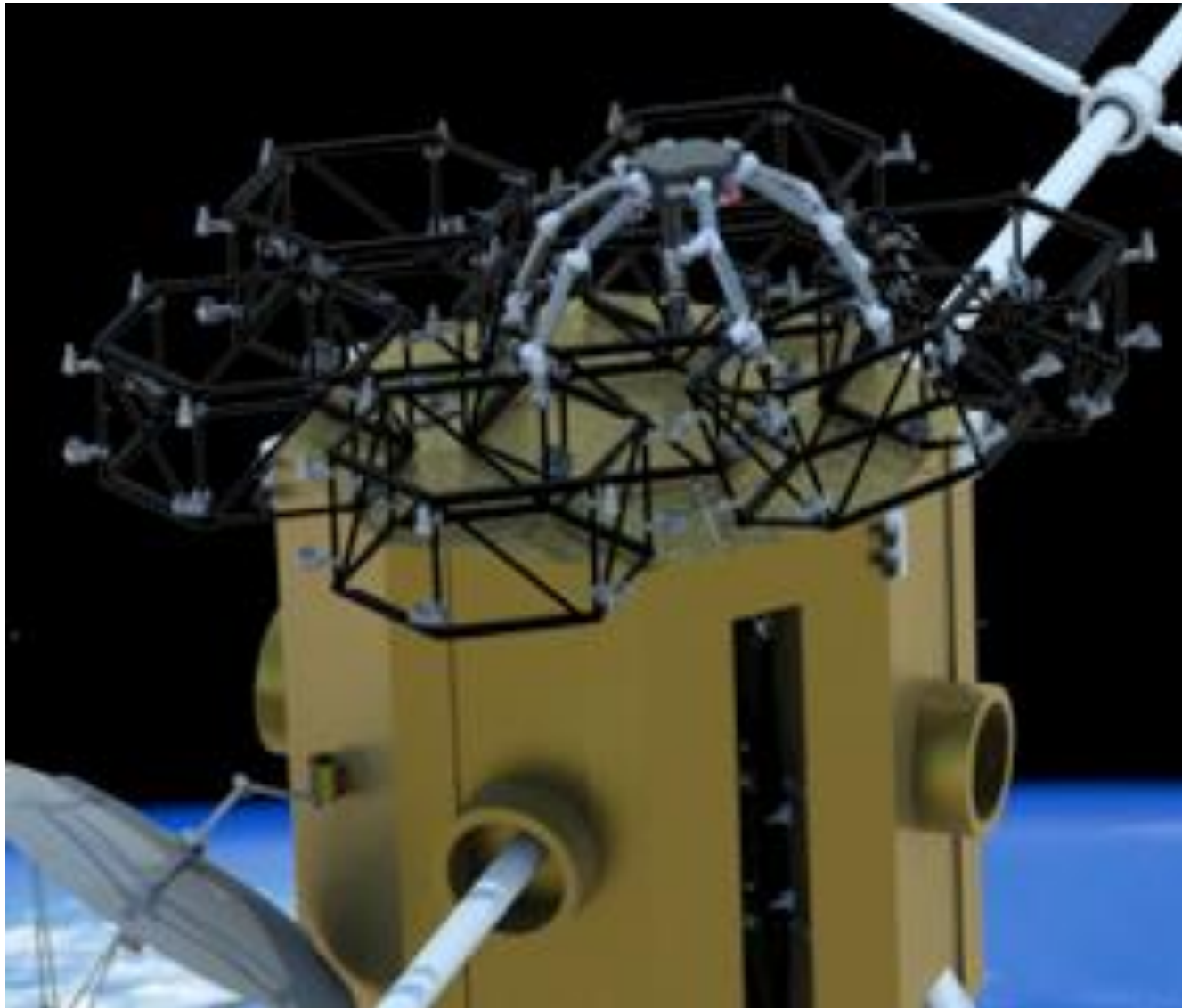

In Space Telescope Assembly Robotics

Multi-limbed robot

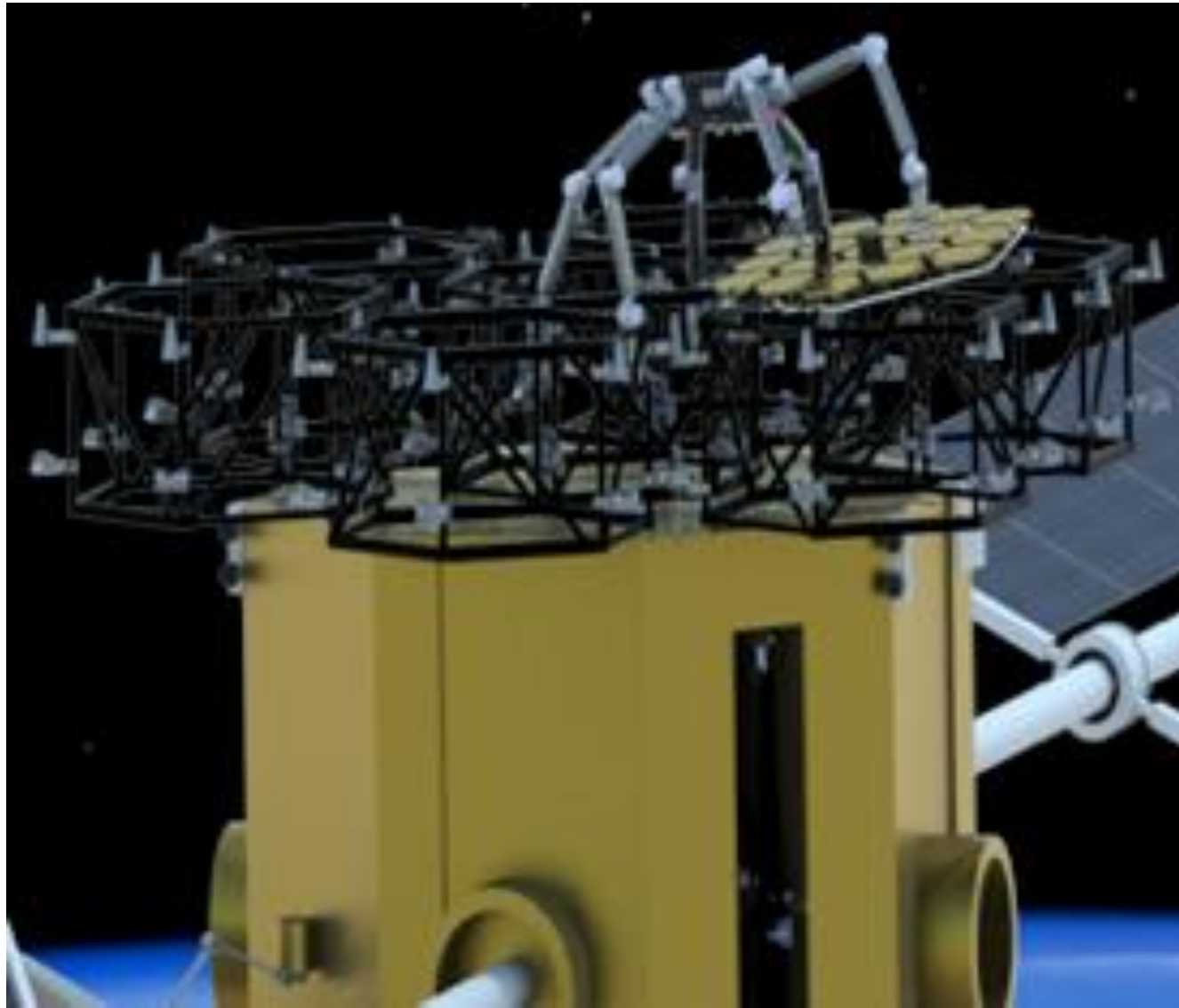

In Space Telescope Assembly Robotics

Multi-limbed robot

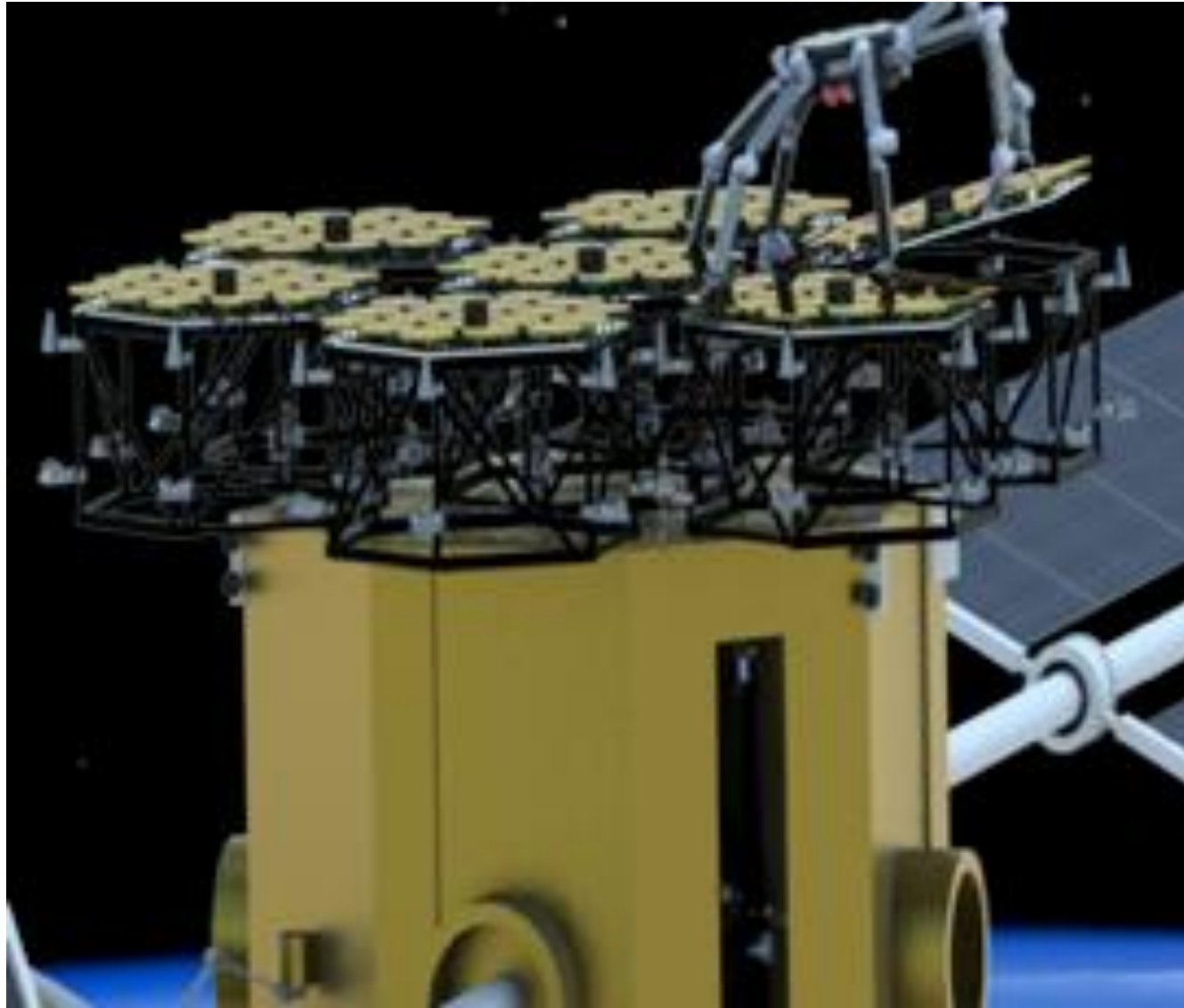

In Space Telescope Assembly Robotics

Unobscured Ritchey-Chretien

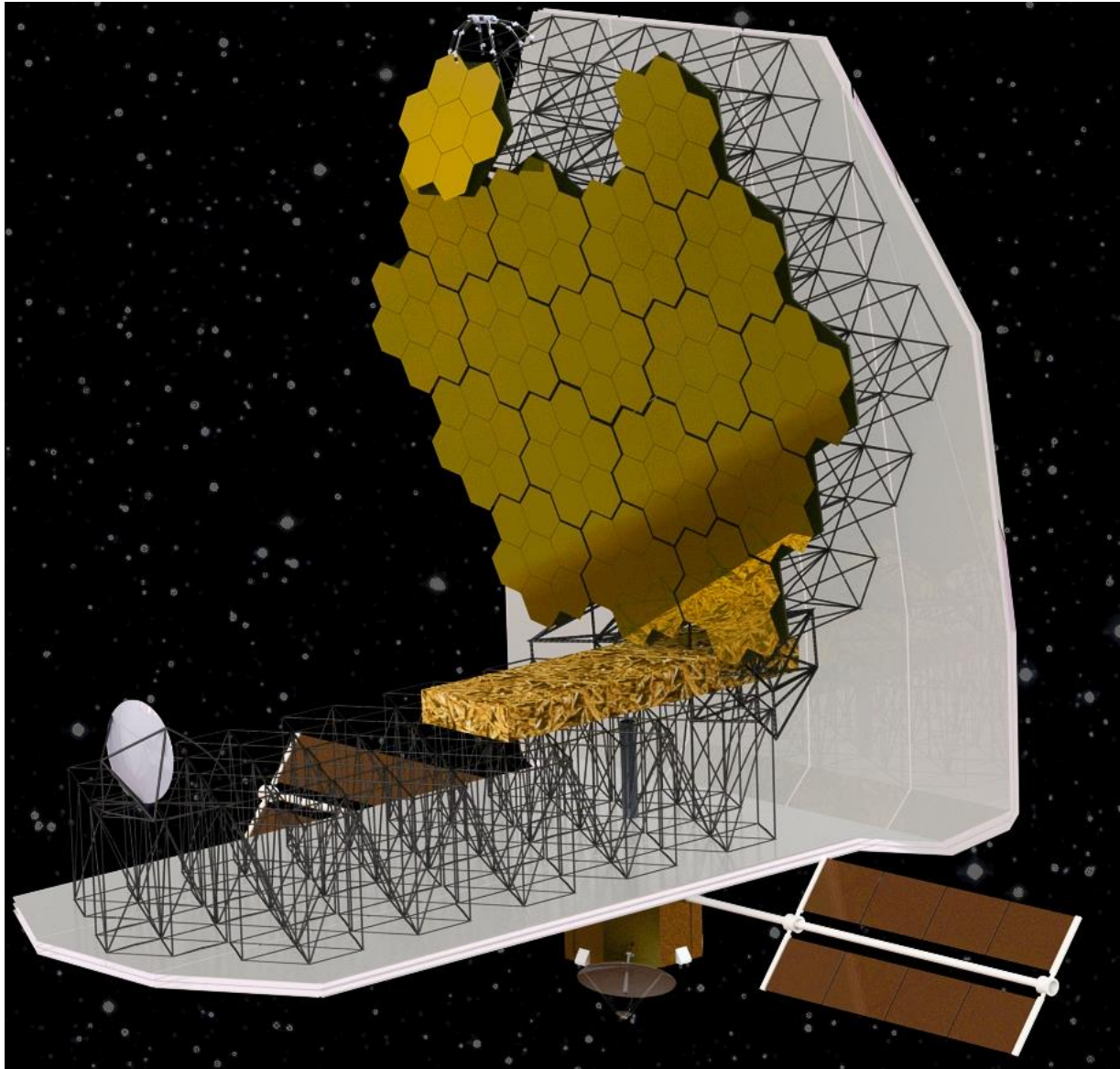

In-Lab Telescope Truss Assembly Robotics

DARPA-funded JPL 3-m telescope assembly demo

Stowed DTMs



Robotically Deploy

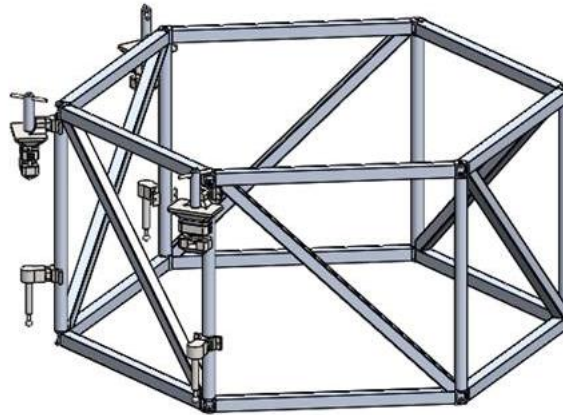

Use adjustable structural and power interconnects

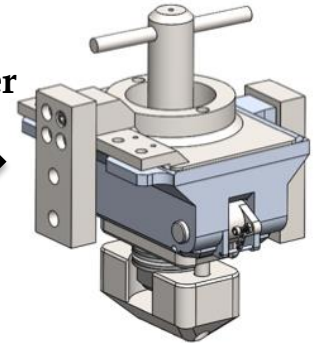

Autonomous mobile manipulation for precision repeated robotic assembly



Central Truss

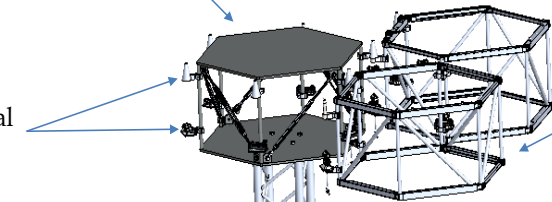

Deployable Trusses

Electromechanical Interconnects

Assemble 3m closed kinematic truss around a central hub (spacecraft surrogate)

April tags

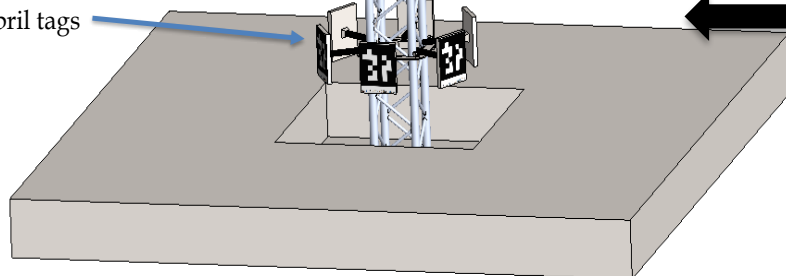

Floor

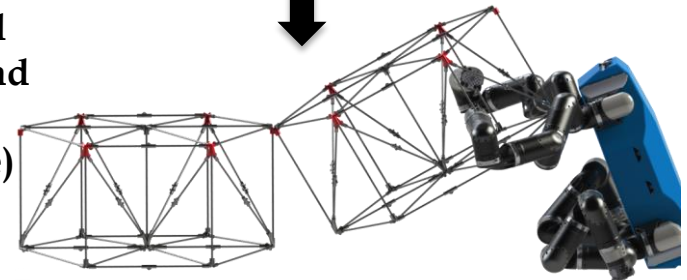

In-Lab Telescope Truss Assembly Robotics

DARPA-funded JPL 3 m telescope assembly demo



In-Space Telescope Assembly Robotics Risk Reduction

Dr. Rudranarayan Mukherjee (PI), Dr. Paul Backes, Charles Bergh,
Jason Carlton, Kyle Edelberg, Blair Emmanuel, Dr. Sisir Karumanchi,
Brett Kennedy, Dr. Junggon Kim, Jeremy Nash, Russell Smith

Jet Propulsion Laboratory, California Institute of Technology
Pasadena California 91109 USA

Program Manager: Dr. Lindsay Millard
DARPA Tactical Technology Office

© 2017 California Institute of Technology. Government sponsorship acknowledged.

Large Solution Space for In-Space Assembly



Cis-lunar station

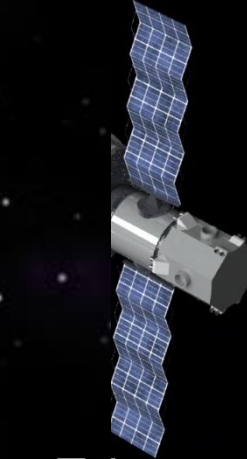

Telescope spacecraft bus

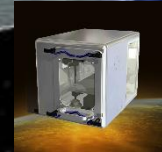

In-space manufacturing

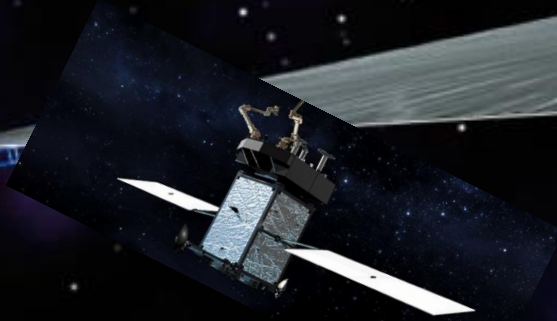

Free-flying servicer



Mobile assembly robot



Fixed assembly robot



Astronaut support

© 2017 California Institute of Technology. Government sponsorship acknowledged.

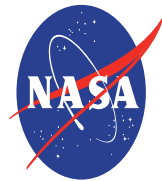

Jet Propulsion Laboratory
California Institute of Technology

jpl.nasa.gov