

Habitable Exoplanet Imager

Optical Telescope Structural Design and Performance Prediction

H. Philip Stahl

Contributors

JPL

- Stefan Martin
- Scott Howe
- Gary Kuan
- Keith Warfield
- Team X

MSFC

- Thomas Brooks, NASA
- Jacqueline Davis, NASA
- Brent Knight, NASA
- William Arnold, AI Solutions
- Mike Baysinger, ESSA
- Jay Garcia, ESSA
- Jonathon Gaskin, UNCC
- Ronald Hunt, ESSA
- Andrew Singleton, ESSA
- Mary Caldwell, ESSA
- Melissa Therrell, ESSA

HabEx

Habitable Exoplanet Imaging Mission (HabEx) is a concept for a mission to directly image and characterize planetary systems around Sun-like stars.

In addition to the search for life on Earth-like exoplanets, HabEx will enable a broad range of general astrophysics science enabled by 100 to 2500 nm spectral range and 3 x 3 arc-minute FOV.

HabEx is one of four mission concepts currently being studied for the 2020 Astrophysics Decadal Survey.

OTA Specification

Science Requirements
Launch Vehicle Capacity
Programmatic Constraints



Engineering Specifications

Exoplanet

Habitable Zone Size

Contrast

Contrast

Contrast

Star Size

Architecture

Minimum Telescope Diameter

Mid/High-Spatial Wavefront Error

WFE Stability

Polarization

Line of Sight Stability

Unobscured (off-axis)

General Astrophysics

Diffraction Limit

Spatial Resolution

Low/Mid-Spatial Wavefront Error

Line of Sight Stability

Launch Vehicle

Up-Mass Capacity

Fairing Size

Mass Budget

Architecture (monolithic/segmented)

Programmatic

Budget

Maximum Telescope Diameter

Design Assumptions

Mission with an Internal Coronagraph requires:

- Unobscured Aperture = off-axis
- Stable Wavefront
- Polarization Uniformity = F/2.5 Primary

General Astrophysics:

- 400 nm diffraction limit requires no development effort

Launch Vehicle

- SLS will exist.
 - ‘Baseline’ design mass and volume constraints are secondary to stability.
- ‘Alternative’ designs will be considered for EELV.

The Most important Design Constraints are:

- Line of Sight Stability
- Wavefront Stability

Mission with Star Shade only can be on-axis and not ‘ultra-stable’.

Optical Telescope Assembly (OTA) Specifications

Architecture	Unobscured Off-Axis F/2.5 TMA
Aperture Diameter	4-meters Monolithic (Minimum) 6.5-meters Segmented or Monolithic (Maximum)
Mass Budget	< 10,000 kg (excluding science instruments & spacecraft)
LOS Stability	< 2.5 milli-arc-second on-sky jitter (astrophysics and starshade) < 0.5 milli-arc-second on-sky jitter (coronagraph)
Diffraction Limit	400 nm (assumed to be achievable)
Wavefront Error	30 nm rms Total (assumed achievable)
Primary Mirror (cpd = cycles/diameter)	Total SFE < 7 nm rms Low-Order (< 30 cpd) < 5 nm rms Mid-Spatial (30 to 90 cpd) < 4 nm rms High-Spatial (>90 cpd) < 2 nm rms Roughness < 1 nm rms
Wavefront Stability	< 2 nm rms (astrophysics and starshade) < 10 to 500 pm rms depending on spatial frequency (coronagraph)

4-meter Monolithic F/2.5 Off-Axis Concept

fits inside SLS

Mission Architecture Constraints

Mission Architecture design constraints:

- Minimum Aperture for science is 4 meters.
- Coronagraph desires unobscured off-axis optical design
- Because of coronagraph polarization sensitivity, the primary mirror is F/2.5 which defines a PM/SM distance of ~ 9 meters.
- For thermal stability and polarization, there is a desire to place the science instruments beside the PM rather than behind it.
- Forward Scarf limits close approach angle to Sun.

HabEx 4-m Off-Axis Initial Concept

Observatory = OTA (PM/SM/Tube) & Science Instruments.

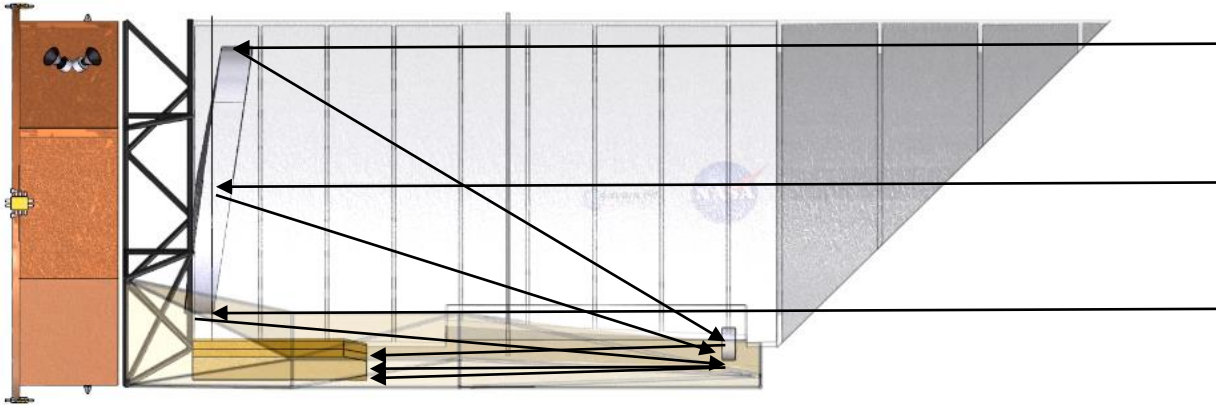

Observatory
attaches to
Spacecraft.

Solar Panels on
Sunshade attach
to Spacecraft.

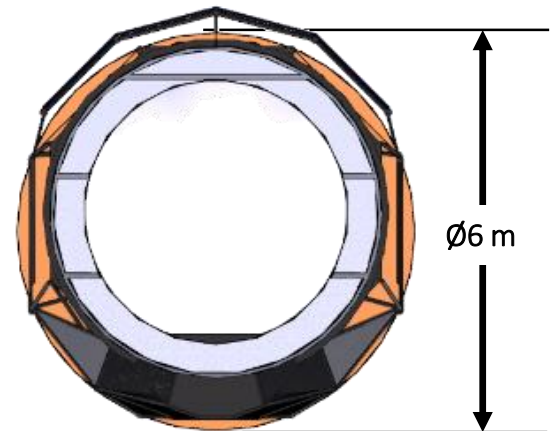
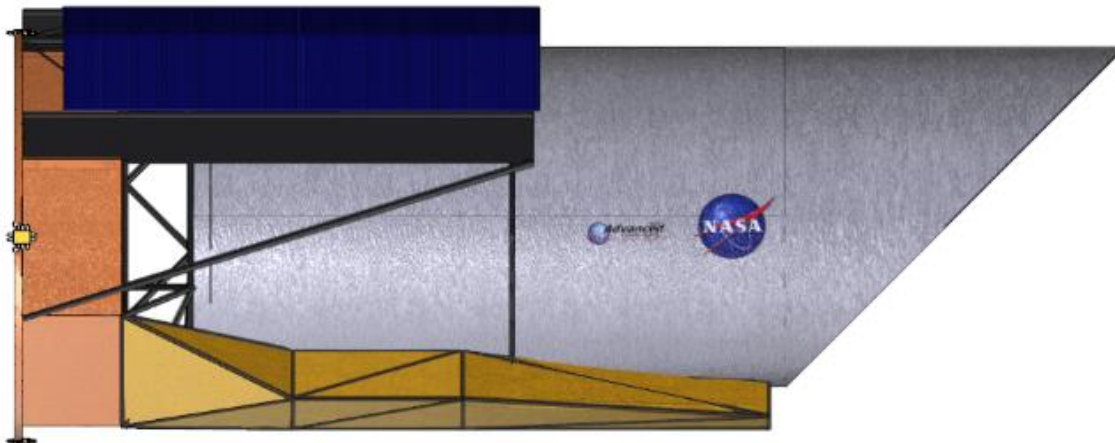

HabEx 4-m Off-Axis Initial Concept

Four Science Instruments:

Coronagraph (imager and spectrograph)

Starshade Imager (imager and spectrograph)

General Astrophysics Workhorse Camera (imager and spectrograph)

General Astrophysics UV Spectrograph

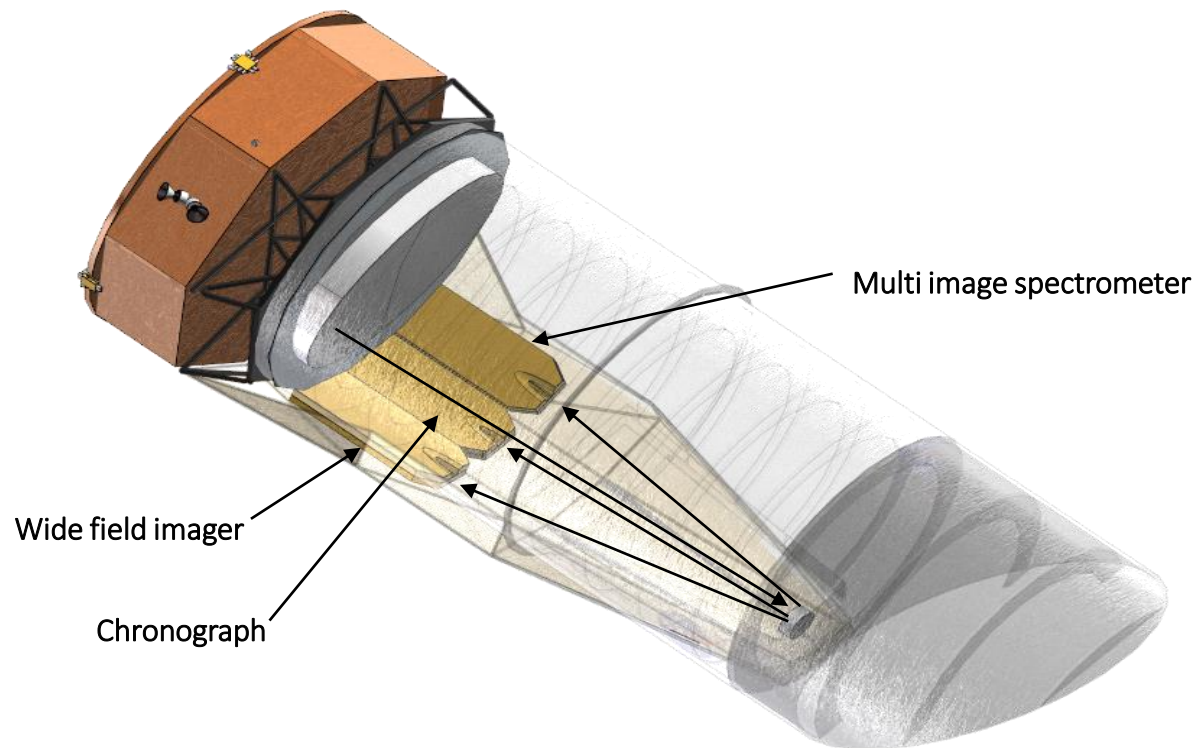

Mission Architecture vs Launch Vehicle

SLS Volume and Mass Capacity enables Mission Architecture.

- 8.4-m Long Fairing on Block I Core
- 7.5 meter dynamic envelop enables 4-m PM with SI on side
 - Could accommodate up to 6-m PM with Si on side.
- 27.4 m height enables dual launch of observatory & star shade
 - 4-m Observatory Only could be launched with no deployments
 - 4-m Observatory and Star Shade could be dual launched with deployment of forward scarf
 - 6-m Observatory Only could be launched with deployed forward scarf
- Mass to SE-L2 = 44 mt

Initial Launch Configuration Options

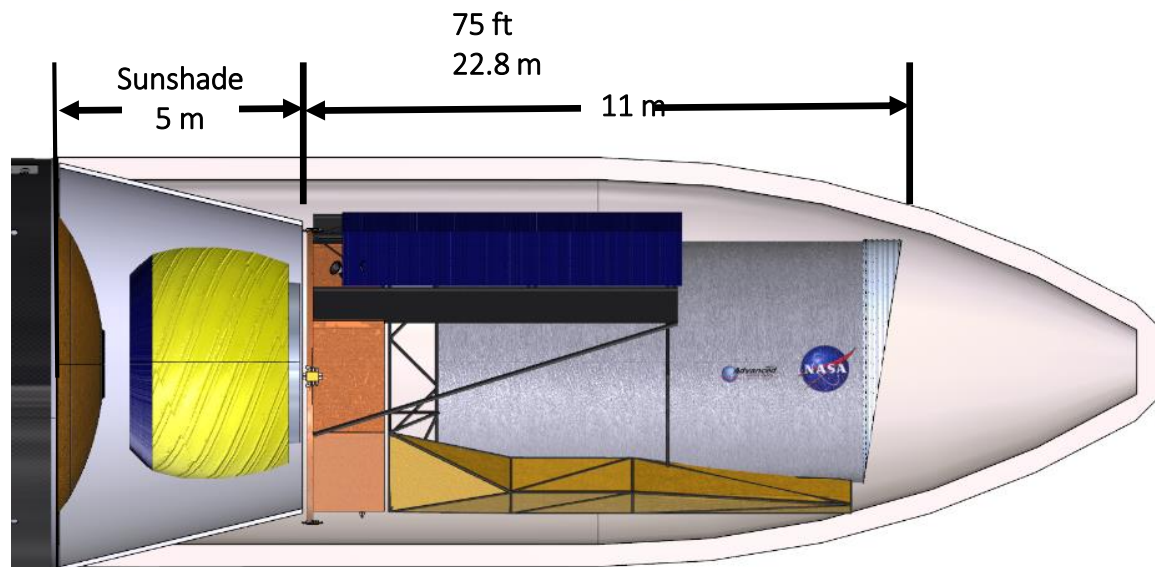
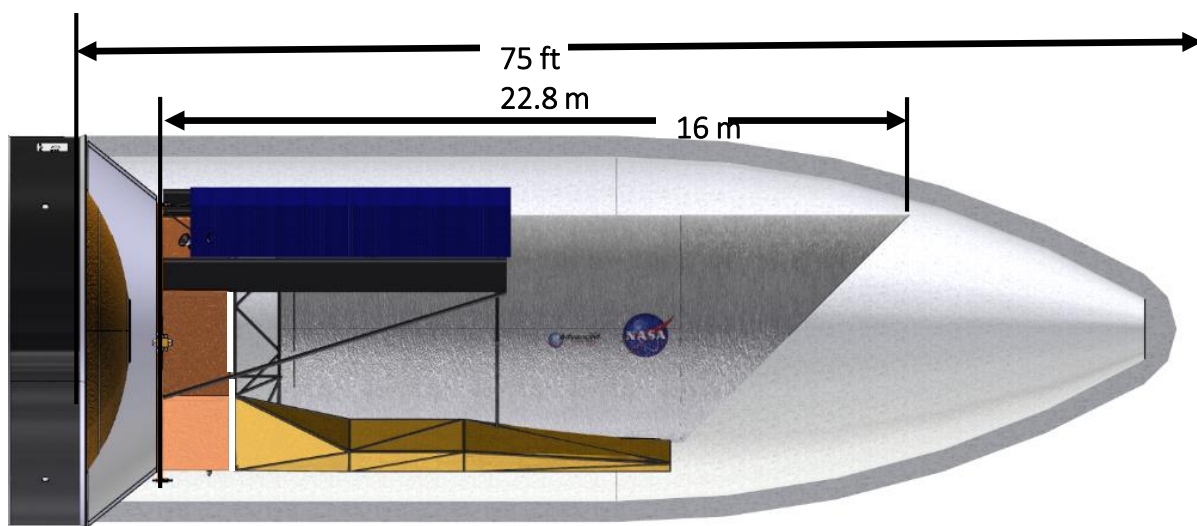

HabEx Baseline Concept

Co-Launch Observatory and Star Shade in SLS 8.4-m Long Fairing on Block 1B core.

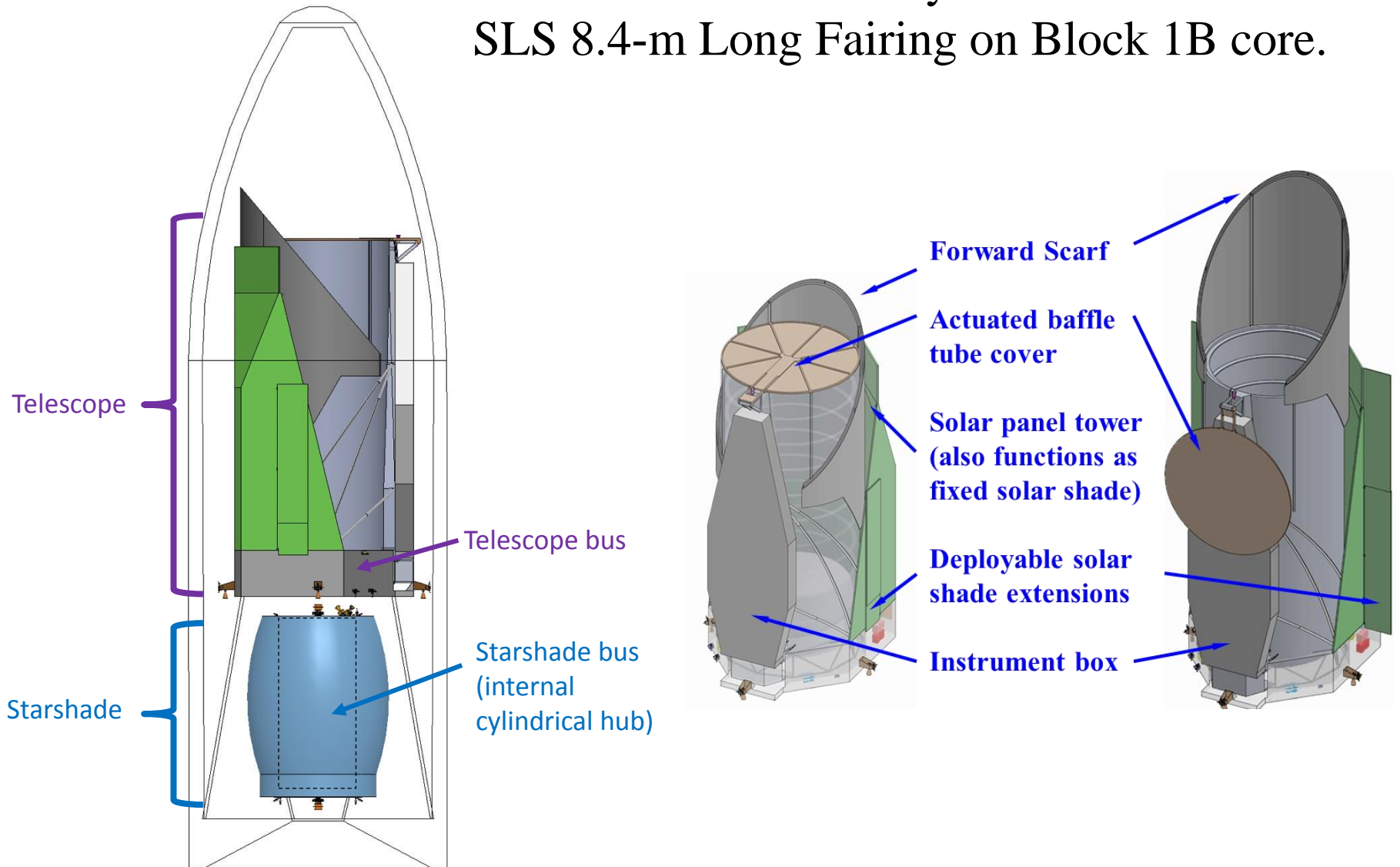

Telescope Structure Design:

Volume & Mass

HabEx Telescope Design: CAD

Optical Design for Telescope and Instruments provide by JPL and imported into CAD via STEP files.

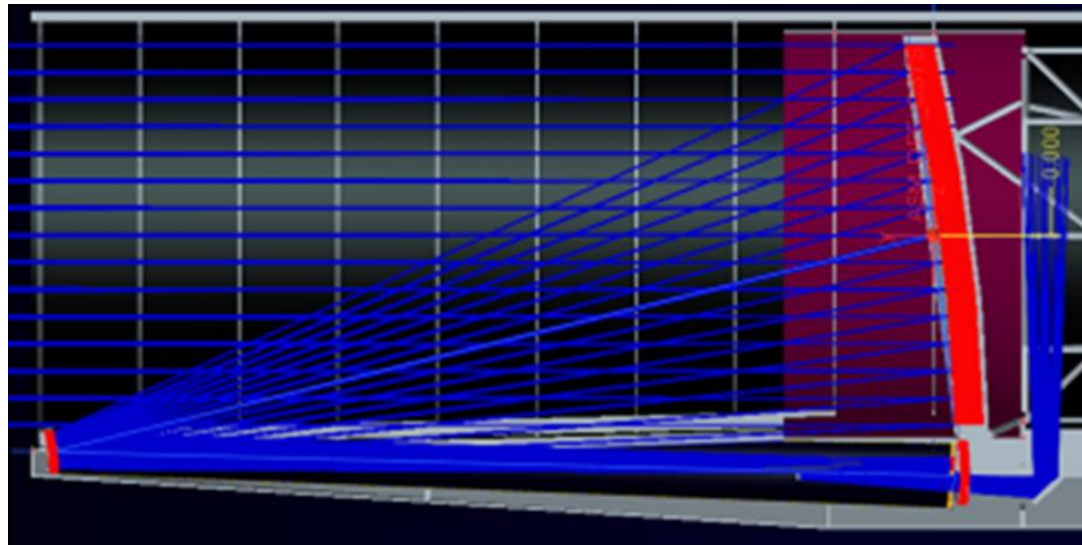
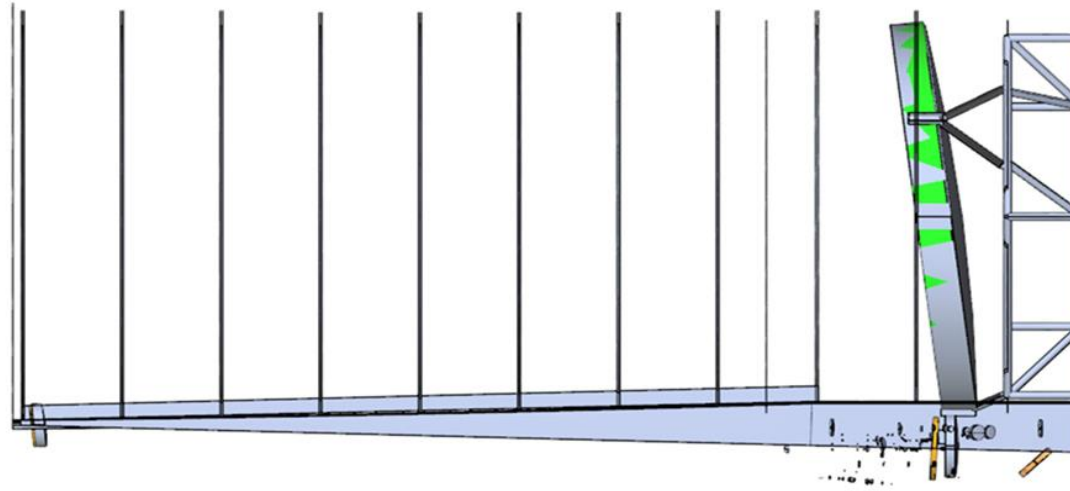

Select CAD views

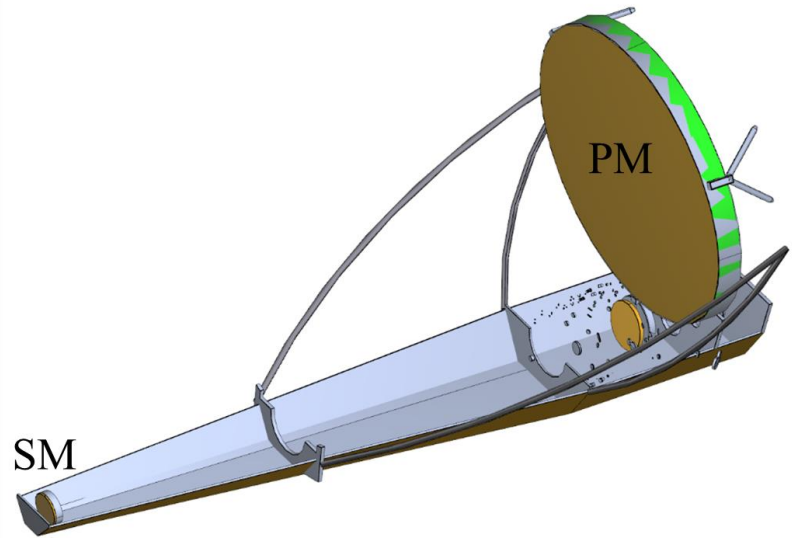
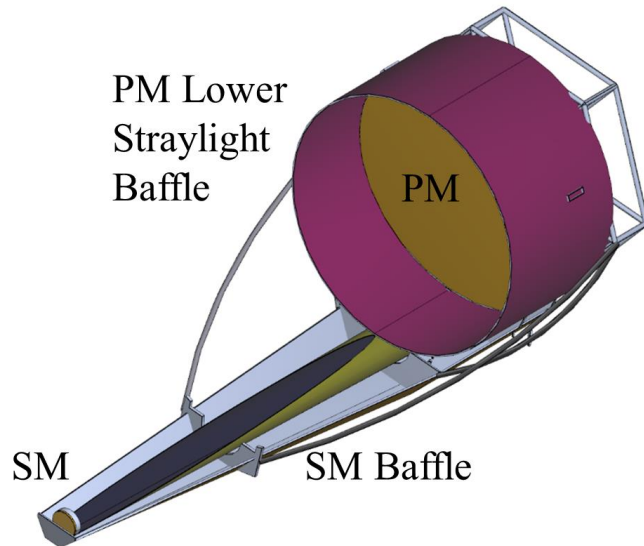
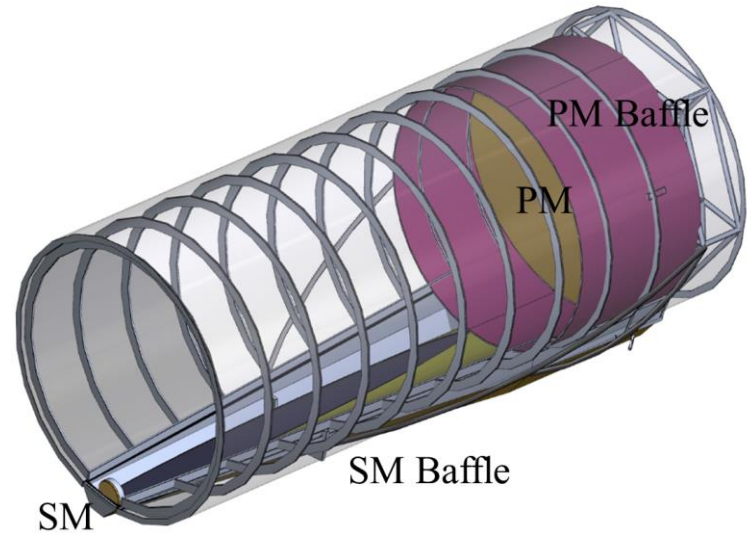
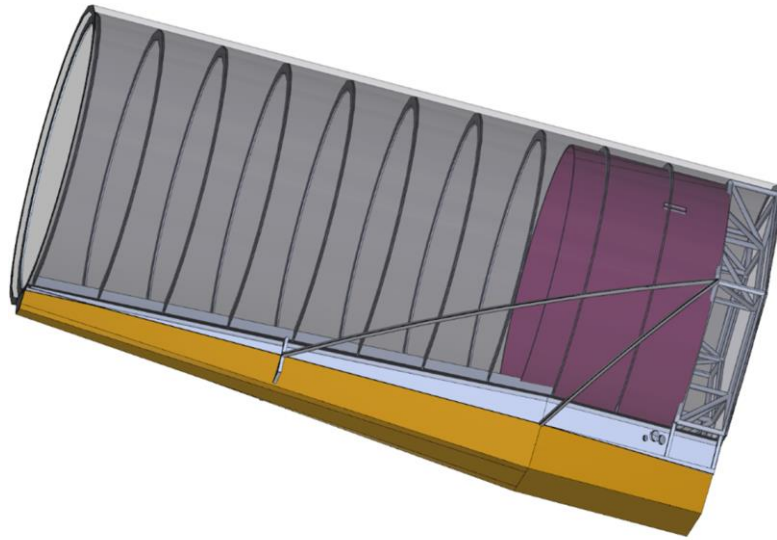

HabEx Telescope Design: FEM

To evaluate opto-mechanical performance, created FEM of Structural Elements.

Changed exo-skeleton to lateral exo-truss elements connecting to the internal straylight baffles.

Straylight baffles are not continuous, because beam path.

PM Truss depth arbitrarily set at 2-meters based on available SLS fairing height.

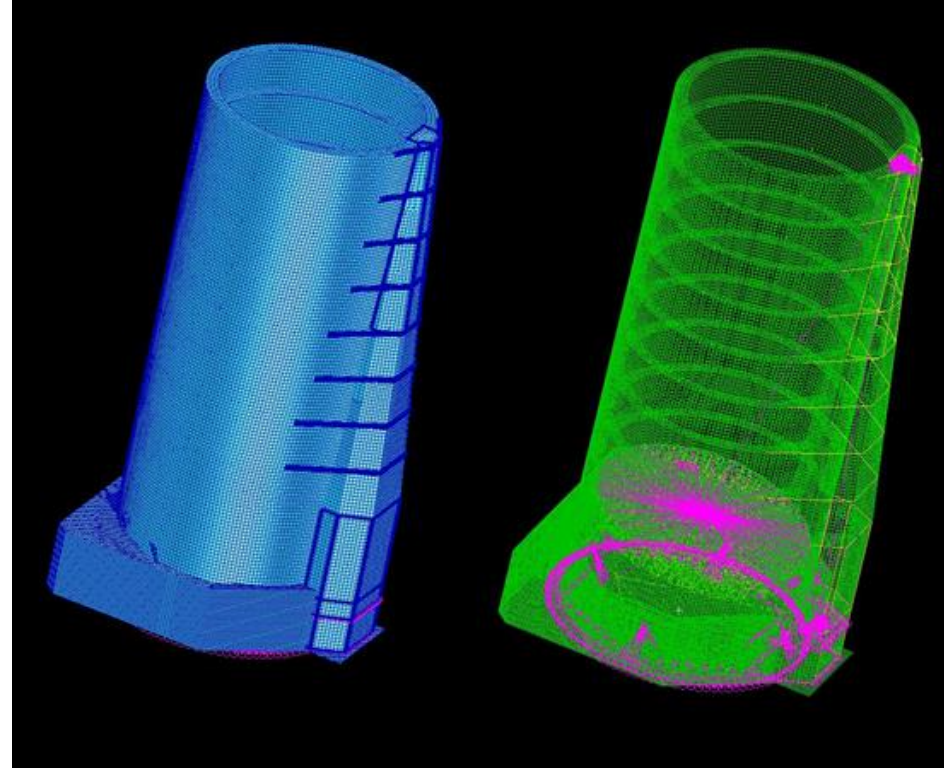

HabEx Baseline Concept

By using microthruster instead of reaction wheels, it is possible to integrate the spacecraft bus with the primary mirror assembly allowing for a shorter total payload height

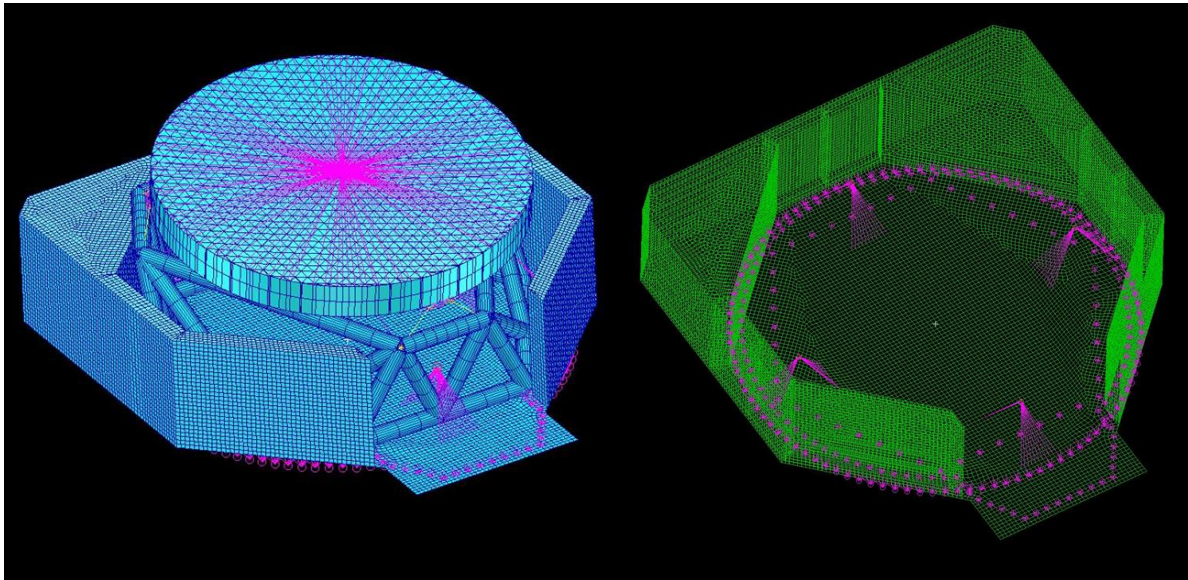

Science Instrument & Spacecraft Bus Mass

Mass provided by JPL Team X:

- Science Instruments 1464 kg
- Spacecraft Bus 3600 kg

Analysis indicates that Science Instrument mass has negligible effect on dynamic performance.

Instruments

UV Spectrometer = 274 kg

Coronagraph = 650 kg

Wide Field Imager = 230 kg

Star Shade Camera = 210 kg

UV Spectrometer Focal Plane
& Electronics = 100 kg

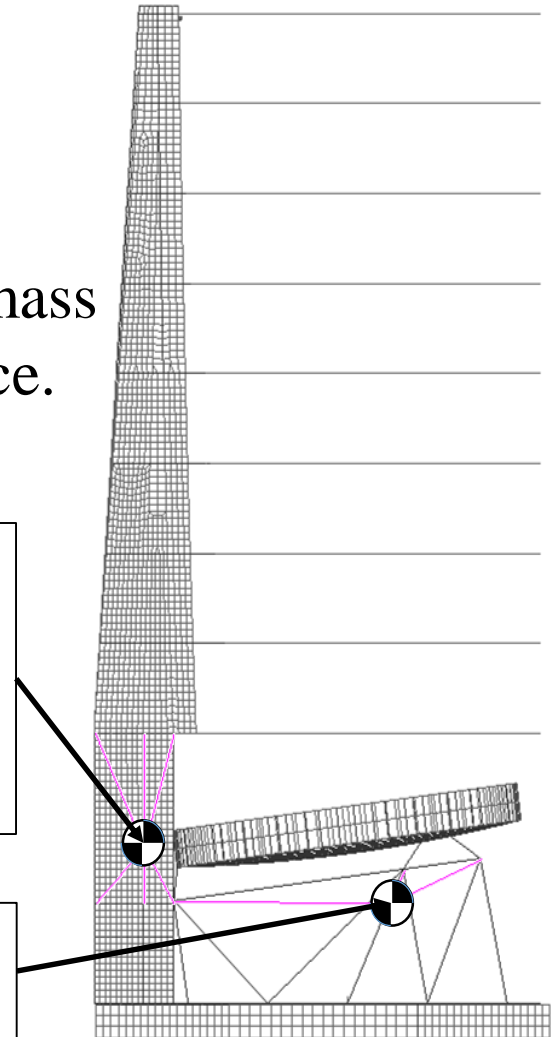

HabEx Telescope Design: Mass Estimate

Secondary Mirror
Mass = 10 kg



Tube / Tower
Mass = 3062 kg

Tertiary Mirror
Mass = 20 kg

Sci Instruments
Mass = 1464 kg

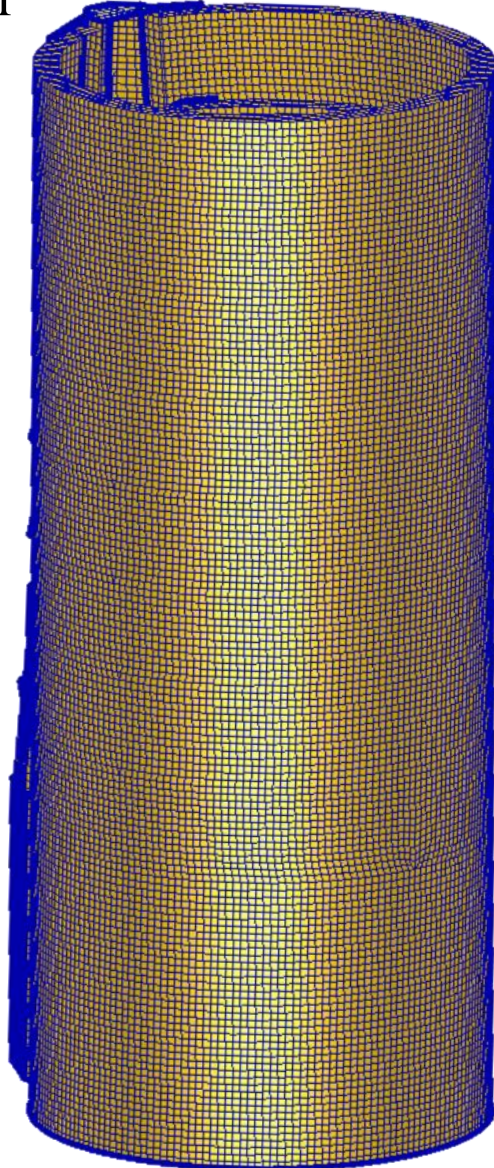

Total Observatory Mass
Mass = 11,049 kg

Optical Telescope Assembly
Mass = 5985 kg
(excluding BUS & Instruments)

Primary Mirror Assembly
Mass = 2893 kg

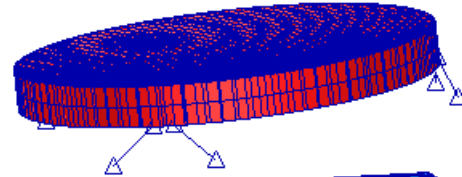

Primary Mirror
Mass = 1652 kg

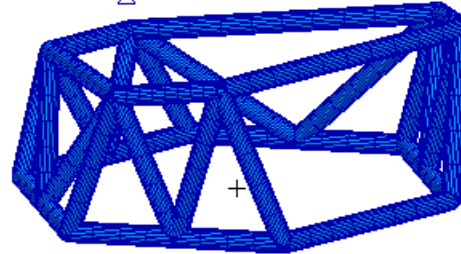

PM Truss
Mass = 1241 kg

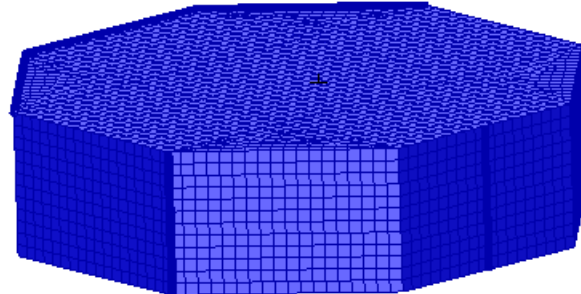

Spacecraft BUS
Mass = 3600 kg

Telescope Specifications

Line of Sight Analysis
Wavefront Stability Analysis

Optical Telescope Assembly Structure

A primary purpose of the OTA Structure is to facilitate the alignment of the optical system and maintain that alignment to the required tolerances over all operating conditions: thermal, mechanical, space, etc.

So, the key question is – what are the required tolerances.

Tolerances can be derived from:

- Line of Sight Stability Requirement

- Wavefront Stability Requirement

Line of Sight (LOS) Stability Specification

Telescope's on-sky LOS Stability specification includes temporal frequency.

It is assumed that a laser-truss or low-order wavefront-sensor (LOWFS) system can sense LOS drift/vibration at frequencies below 10 Hz and control actuators or a fine steering mirror (FSM) to correct such LOS errors.

Temporal Frequency

< 10 Hz

> 10 Hz

On-Sky LOS Stability

< 1 mas rms per axis

< 0.5 mas rms per axis

(only required for internal coronagraph)

NOTE: For Baseline Optical Design, 0.5 mas on-sky = 40 mas at FSM.

Discussion:

- Coronagraph requires internal LOS Stability to be < 0.5 mas to avoid beam shear.
- Coronagraph will have a LOWFS/FSM which is assumed able to reduce 2.5 mas LOS motion of frequency < ~10 Hz to required < 0.5 mas. But not > ~ 10 Hz.
- Astrophysics Instruments will not have FSM and requires LOS to be stable to < 1/10th of PSF radius.
- For 4-m telescope, PSF ($1.22\lambda/D$ half-angle) at 400 nm is ~122 n-radian (~ 25 mas)
- For 6-m telescope, PSF ($1.22\lambda/D$ half-angle) at 400 nm is ~ 80 n-radian (~ 16 mas)

LOS Stability State of Art

HST LOS stability is 8 mas (1/10 full PSF angle)

JWST LOS Jitter before FSM is < 7 mas (1/10 half PSF angle)

JWST LOS Jitter specification after FSM < 3.7 mas

- SM motion @ ~ 7 Hz
- PM motion @ ~ 17 Hz

Because of dampening, a warm JWST might have LOS stability of < 0.5 mas.

Feinberg, et. al., “A Cost-effective and Serviceable ATLAST 9.2m Telescope Architecture”, *Proc. SPIE*. 9143. (August 02, 2014) doi: 10.1117/12.2054915

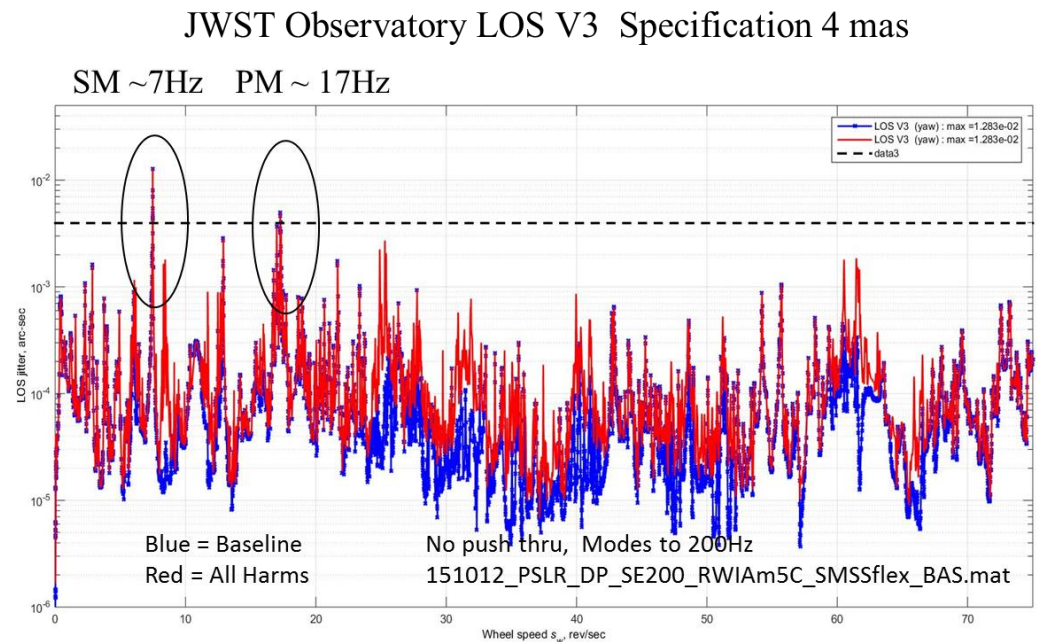

LOS Stability Sensitivities

Zemax Tolerance Analysis of the LOS error produced by Rigid Body (6-DOF) Misalignments of the Primary, Secondary and Tertiary Mirrors for the baseline F/2.5 optical design.

LOS Sensitivity to Component Rigid Body Alignment						
Alignment	ZEMAX	Tolerance	Units	X-Tilt	Y-Tilt	Units
PM X-Decenter	DX	1	nm	1.72	0	mas
PM Y-Decenter	DY	1	nm	0	1.67	mas
PM Z-Despace	DZ	1	nm	0	0.43	mas
PM X-Tilt (Y-Rotation)	TY	1	mas	-165.31	0	mas
PM Y-Tilt (X-Rotation)	TX	1	mas	0	167.98	mas
PM Z-Rotation	TZ	1	mas	20.88	0	mas
SM X-Decenter	DX	1	nm	-1.53	0	mas
SM Y-Decenter	DY	1	nm	0	-1.48	mas
SM Z-Despace	DZ	1	nm	0	-0.43	mas
SM X-Tilt (Y-Rotation)	TY	1	mas	14.54	0	mas
SM Y-Tilt (X-Rotation)	TX	1	mas	0	-14.8	mas
SM Z-Rotation	TZ	1	mas	-1.62	0	mas
TM X-Decenter	DX	1	nm	-0.19	0	mas
TM Y-Decenter	DY	1	nm	0	-.019	mas
TM Z-Despace	DZ	1	nm	0	0	mas
TM X-Tilt (Y-Rotation)	TY	1	mas	2.02	0	mas
TM Y-Tilt (X-Rotation)	TX	1	mas	0	-2.02	mas
TM Z-Rotation	TZ	1	mas	0.0036	0	mas

Preliminary LOS Stability Tolerances

Using alignment sensitivity matrix, an excel spreadsheet evaluates different alignment allocations to produce a specification for each component.

This allocation is based on dynamic analysis. Most important is PM Decenter.

LOS RSS Error				40.00 mas	
				ALLOCATION (one sided PV)	
Alignment	ZEMAX	Tolerance	units	RSS	Units
PM X-Decenter	DX	15	nanometer	25.80	mas
PM Y-Decenter	DY	15	nanometer	25.05	mas
PM Z-Despace	DZ	8	nanometer	3.44	mas
PM Y-Tilt	TX	0.25	nano-radian	8.66	mas
PM X-Tilt	TY	0.25	nano-radian	8.52	mas
PM Z-Rotation	TZ	0.5	nano-radian	2.15	mas
SM X-Decenter	DX	4	nanometer	6.12	mas
SM Y-Decenter	DY	4	nanometer	5.92	mas
SM Z-Despace	DZ	8	nanometer	3.44	mas
SM Y-Tilt	TX	0.5	nano-radian	1.53	mas
SM X-Tilt	TY	0.5	nano-radian	1.50	mas
SM Z-Rotation	TZ	0.5	nano-radian	0.17	mas
TM X-Decenter	DX	10	nanometer	1.90	mas
TM Y-Decenter	DY	10	nanometer	1.90	mas
TM Z-Despace	DZ	1000	nanometer	0.00	mas
TM Y-Tilt	TX	10	nano-radian	4.17	mas
TM X-Tilt	TY	10	nano-radian	4.17	mas
TM Z-Rotation	TZ	1000	nano-radian	0.74	mas
				105.18	mas
				39.86	mas

Notes:

- For a 4-meter PM, 1 nano-radian of tilt is equal to 2 nm PV.
- For a 0.5-meter SM, 1 nan-radian of tilt is equal to 0.25 nm PV.
- Eliminated TM/PM Y-Decenter by coupling PM to TM in Y-axis.

WFE Stability Specification

WFE stability specification includes spatial and temporal frequency
(rms WFE per WFSC update cycle)

For a Telescope with an internal coronagraph (assuming VVC-6)

- Low-Order < 0.5 nm rms per update cycle
- Mid-Spatial Frequency < 0.01 nm rms per update cycle

For a Telescope without an internal coronagraph

- WFE Stability < 2 nm rms maximum

WFE Stability State of Art

JWST WFE stability specification < 13 nm rms

- SM motion @ ~ 7 Hz
- PM motion @ ~ 17 Hz
- PM Segment motion @ ~ 40 Hz

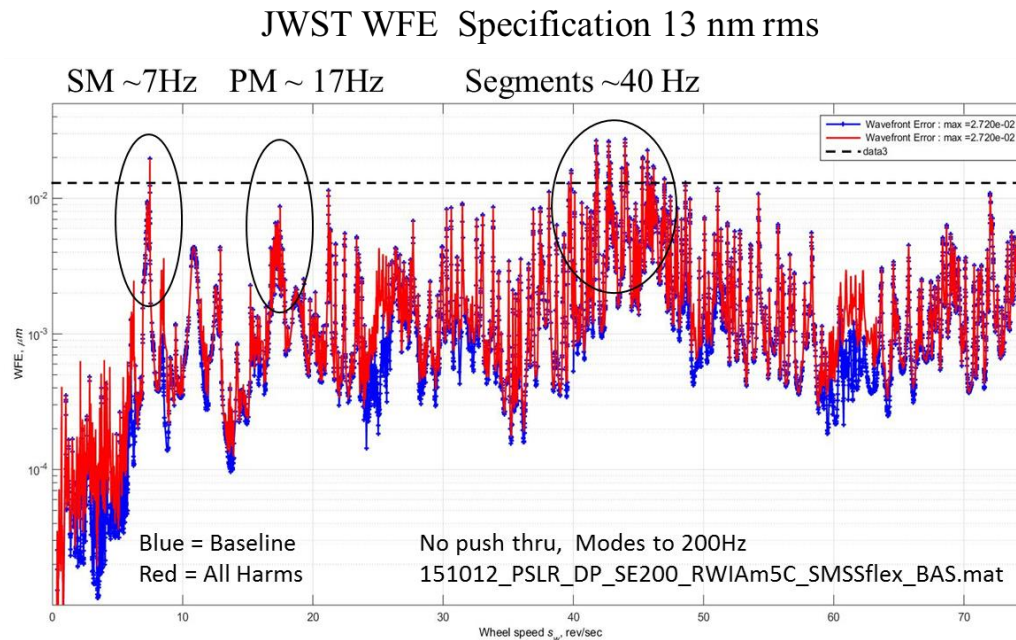

Per Feinberg, et. al., because of dampening, a warm JWST may have WFE stability of < 2 nm rms.



Wavefront Error (WFE) Stability Specification

WFE stability specification depends on the coronagraph.

For Vector Vortex, higher charge (i.e. 6 or 8 vs 4) rejects more WFE

Aberration	Indices		Allowable RMS wavefront error (nm) per mode			
	<i>n</i>	<i>m</i>	charge 4	charge 6	charge 8	charge 10
Tip-tilt	1	±1	1.1	5.9	14	26
Defocus	2	0	0.8	4.6	12	26
Astigmatism	2	±2	0.0067	1.1	0.90	5
Coma	3	±1	0.0062	0.66	0.82	5
Spherical	4	0	0.0048	0.51	0.73	6
Trefoil	3	±3	0.0072	0.0063	0.57	0.67
2 nd Astig.	4	±2	0.0080	0.0068	0.67	0.73
2 nd Coma	5	±1	0.0036	0.0048	0.69	0.85
2 nd Spher.	6	0	0.0025	0.0027	0.84	1
Quadrafoil	4	±4	0.0078	0.0080	0.0061	0.53
2 nd Trefoil	5	±3	0.0051	0.0056	0.0043	0.72
3 rd Astig.	6	±2	0.0023	0.0035	0.0034	0.81
3 rd Coma	7	±1	0.0018	0.0022	0.0036	1.18
3 rd Spher.	8	0	0.0018	0.0018	0.0033	1.49

Garreth Ruane, June 2017

	not rejected
	first-order rejection
	> first-order rejection

Each Aberration can be mapped to a PM & SM rigid body motions; amplitudes given by Zemax alignment tolerance.

WFE Stability Sensitivities

Zemax Tolerance Analysis of the WFE produced by Rigid Body (6-DOF) Misalignments of the Primary, Secondary and Tertiary Mirrors for the baseline F/2.5 optical design.

	Primary Mirror or M1						Secondary Mirror or M2					
	DX	DY	DZ	TX	TY	TZ	DX	DY	DZ	TX	TY	TZ
	micron	micron	micron	arc-sec	arc-sec	arc-sec	micron	micron	micron	arc-sec	arc-sec	arc-sec
	1	1	1	0.1	0.10	0.1	1	1	1	0.1	0.1	0.1
	nm	nm	nm	n-rad	n-rad	n-rad	nm	nm	nm	n-rad	n-rad	n-rad
	1000	1000	1000	484.81	484.81	484.81	1000	1000	1000	484.81	484.81	484.81
Piston	-0.000004	-0.009726	0.076058	0.000020	0.000002	-0.000001	-0.000115	0.009713	-0.077023	-0.000004	-0.000119	-0.000003
X-Tilt	0.002597	0.000000	0.000001	0.000000	-0.001581	0.000812	-0.002593	0.000000	-0.000004	0.000000	0.000282	-0.000071
Y-Tilt	0.000004	0.002356	0.002554	0.001635	-0.000003	0.000001	-0.000004	-0.002352	-0.002555	-0.000291	0.000000	0.000000
Defocus	-0.000002	-0.005585	0.043749	0.000017	0.000002	-0.000001	-0.000066	0.005577	-0.044306	-0.000003	-0.000069	-0.000002
Y-Astig	-0.004010	-0.000043	-0.000001	-0.000053	0.002441	-0.001254	0.004005	0.000038	0.000006	0.000070	-0.000435	0.000110
X-Astig	-0.000042	0.003889	0.001980	0.002525	0.000053	-0.000013	0.000037	-0.003883	-0.001981	-0.000450	-0.000070	0.000001
Y-Coma	0.000001	0.000829	0.000896	0.000575	-0.000001	0.000000	-0.000001	-0.000828	-0.000897	-0.000102	0.000000	0.000000
X-Coma	0.000913	0.000000	0.000000	0.000000	-0.000556	0.000286	-0.000912	0.000000	-0.000002	0.000000	0.000099	-0.000025
Y-Trefoil	0.000000	0.000042	0.000021	0.000027	0.000000	0.000000	0.000000	-0.000042	-0.000021	-0.000005	0.000000	0.000000
X-Trefoil	0.000043	0.000000	0.000000	0.000000	-0.000026	0.000014	-0.000043	0.000000	0.000000	0.000000	0.000005	-0.000001
Spherical	0.000000	0.000023	-0.000126	0.000004	0.000000	0.000000	0.000000	-0.000023	0.000126	-0.000001	0.000000	0.000000
2 astig	0.000000	-0.000016	-0.000012	-0.000010	0.000000	0.000000	0.000000	0.000016	0.000012	0.000002	0.000000	0.000000
2 astig	0.000017	0.000000	0.000000	0.000000	-0.000010	0.000005	-0.000017	0.000000	0.000000	0.000000	0.000002	0.000000
Quadrafoil	0.000000	0.000000	0.000000	0.000000	0.000000	0.000000	0.000000	0.000000	0.000000	0.000000	0.000000	0.000000
Quadrafoil	0.000000	0.000000	0.000000	0.000000	0.000000	0.000000	0.000000	0.000000	0.000000	0.000000	0.000000	0.000000
2 coma	-0.000003	0.000000	0.000000	0.000000	0.000002	-0.000001	0.000003	0.000000	0.000000	0.000000	0.000000	0.000000
2 coma	0.000000	-0.000002	-0.000004	-0.000002	0.000000	0.000000	0.000000	0.000002	0.000004	0.000000	0.000000	0.000000
2 trefoil	0.000000	0.000000	0.000000	0.000000	0.000000	0.000000	0.000000	0.000000	0.000000	0.000000	0.000000	0.000000
2 trefoil	0.000000	0.000000	0.000000	0.000000	0.000000	0.000000	0.000000	0.000000	0.000000	0.000000	0.000000	0.000000
Pentafoil	0.000000	0.000000	0.000000	0.000000	0.000000	0.000000	0.000000	0.000000	0.000000	0.000000	0.000000	0.000000
Pentafoil	0.000000	0.000000	0.000000	0.000000	0.000000	0.000000	0.000000	0.000000	0.000000	0.000000	0.000000	0.000000

No terms above 2nd order astigmatism contribute any WFE.

Preliminary WFE Stability Tolerances

Using alignment sensitivity matrix, an excel spreadsheet evaluates different alignment allocations to produce a specification for each component.

This allocation is based on dynamic analysis. Most important is PM Decenter.

			Primary Mirror or M1						Secondary Mirror or M2					
			DX	DY	DZ	TX	TY	TZ	DX	DY	DZ	TX	TY	TZ
			X-Decenter	Y-Decenter	Z-Despace	Y-Tilt	X-Tilt	Z-Rotation	X-Decenter	Y-Decenter	Z-Despace	Y-Tilt	X-Tilt	Z-Rotation
			nm	nm	nm	n-rad	n-rad	n-rad	nm	nm	nm	n-rad	n-rad	n-rad
INPUT DOF SPECIFICATION			4.00	4.00	8.00	0.25	0.25	0.50	4.00	4.00	8.00	0.50	0.50	0.50
VVC4 TOLERANCE		WFE												
ISO RMS Zernikes	nm	nm												
Z0 Piston			0.000	-0.010	0.076	0.000	0.000	0.000	0.000	0.010	-0.077	0.000	0.000	0.000
Z1 X-Tilt	1.1	0.0041	0.003	0.000	0.000	0.000	-0.002	0.001	-0.003	0.000	0.000	0.000	0.000	0.000
Z2 Y-Tilt	1.1	0.0052	0.000	0.002	0.003	0.002	0.000	0.000	0.000	-0.002	-0.003	0.000	0.000	0.000
Z3 Focus	0.8	0.0938	0.000	-0.006	0.044	0.000	0.000	0.000	0.000	0.006	-0.044	0.000	0.000	0.000
Z4 X-Astig	0.0067	0.0067	0.000	0.004	0.002	0.003	0.000	0.000	0.000	-0.004	-0.002	0.000	0.000	0.000
Z5 Y-Astig	0.0067	0.0063	-0.004	0.000	0.000	0.000	0.002	-0.001	0.004	0.000	0.000	0.000	0.000	0.000
Z6 X-Coma	0.0062	0.0014	0.001	0.000	0.000	0.000	-0.001	0.000	-0.001	0.000	0.000	0.000	0.000	0.000
Z7 Y-Coma	0.0062	0.0018	0.000	0.001	0.001	0.001	0.000	0.000	0.000	-0.001	-0.001	0.000	0.000	0.000
Z8 Sphere	0.0048	0.0002	0.000	0.000	0.000	0.000	0.000	0.000	0.000	0.000	0.000	0.000	0.000	0.000
Z9 X-Trefoil	0.0072	0.0001	0.000	0.000	0.000	0.000	0.000	0.000	0.000	0.000	0.000	0.000	0.000	0.000
Z10 Y-Trefoil	0.0072	0.0001	0.000	0.000	0.000	0.000	0.000	0.000	0.000	0.000	0.000	0.000	0.000	0.000
Z11 X-2nd Astig	0.008	0.0000	0.000	0.000	0.000	0.000	0.000	0.000	0.000	0.000	0.000	0.000	0.000	0.000
Z12 Y-2nd Astig	0.008	0.0000	0.000	0.000	0.000	0.000	0.000	0.000	0.000	0.000	0.000	0.000	0.000	0.000
Z13 X-2nd Coma	0.0036	0.0000	0.000	0.000	0.000	0.000	0.000	0.000	0.000	0.000	0.000	0.000	0.000	0.000
Z14 Y-2nd Coma	0.0036	0.0000	0.000	0.000	0.000	0.000	0.000	0.000	0.000	0.000	0.000	0.000	0.000	0.000
Z15 2nd Sphere	0.0025	0.0000	0.000	0.000	0.000	0.000	0.000	0.000	0.000	0.000	0.000	0.000	0.000	0.000
Z16 X-Quadrafoil	0.0078	0.0000	0.000	0.000	0.000	0.000	0.000	0.000	0.000	0.000	0.000	0.000	0.000	0.000
Z17 Y-Quadrafoil	0.0078	0.0000	0.000	0.000	0.000	0.000	0.000	0.000	0.000	0.000	0.000	0.000	0.000	0.000
Z18 X-2nd Trefoil	0.0051	0.0000	0.000	0.000	0.000	0.000	0.000	0.000	0.000	0.000	0.000	0.000	0.000	0.000
Z19 Y-2nd Trefoil	0.0051	0.0000	0.000	0.000	0.000	0.000	0.000	0.000	0.000	0.000	0.000	0.000	0.000	0.000
Z20 X-3rd Astig	0.0023	0.0000	0.000	0.000	0.000	0.000	0.000	0.000	0.000	0.000	0.000	0.000	0.000	0.000
Z21 Y-3rd Astig	0.0023	0.0000	0.000	0.000	0.000	0.000	0.000	0.000	0.000	0.000	0.000	0.000	0.000	0.000
Z22 X-3rd Coma	0.0018	0.0000	0.000	0.000	0.000	0.000	0.000	0.000	0.000	0.000	0.000	0.000	0.000	0.000
Z23 Y-3rd Coma	0.0018	0.0000	0.000	0.000	0.000	0.000	0.000	0.000	0.000	0.000	0.000	0.000	0.000	0.000
Z24 3rd Sphere	0.0018	0.0000	0.000	0.000	0.000	0.000	0.000	0.000	0.000	0.000	0.000	0.000	0.000	0.000
TOTAL		0.2609	0.000	-0.008	0.125	0.005	0.000	0.000	0.000	0.008	-0.127	-0.001	0.000	0.000

Preliminary Rigid Body Specification

Combining analysis for LOS and WFE stability, can define the maximum amount of rigid body motion allowed by the primary and secondary mirrors. Tertiary Mirror motion is negligible.

HabEx Optical Component Rigid Body Stability Tolerance Specification				
Alignment	for VVC-4	for 0.5 mas LOS	for VVC-6	Units
PM X-Decenter	4	15	400	nanometers
PM Y-Decenter	4	15	400	nanometers
PM Z-Despace	8	8	500	nanometers
PM X-Tilt (Y-Rotation)	0.25	0.25	5	nano-radians
PM Y-Tilt (X-Rotation)	0.25	0.25	5	nano-radians
PM Z-Rotation	0.5	0.5	5	nano-radians
SM X-Decenter	4	4	400	nanometers
SM Y-Decenter	4	4	400	nanometers
SM Z-Despace	8	8	500	nanometers
SM X-Tilt (Y-Rotation)	0.5	0.5	5	nano-radians
SM Y-Tilt (X-Rotation)	0.5	0.5	5	nano-radians
SM Z-Rotation	0.5	0.5	5	nano-radians
TM X-Decenter	10	10	1000	nanometers
TM Y-Decenter	10	10	1000	nanometers
TM Z-Despace	1000	1000	1000	nanometers
TM X-Tilt (Y-Rotation)	10	10	1000	nano-radians
TM Y-Tilt (X-Rotation)	10	10	1000	nano-radians
TM Z-Rotation	1000	1000	1000	nano-radians

Note #1: VVC-4 requirements are similar to LOS stability.

Note #2: Analysis does not include dynamic WFE from PM.

Design for Stability

Wavefront and Line of Sight Stability has design consequences.

- Mechanical
 - Secondary Mirror Support Structure Dynamic Response – make higher
 - Primary Mirror Dynamic Response – make higher
 - Passive/Active Vibration Isolation – lower acceleration/better isolation
 - Passive/Active Dampening/Control – mass damping
- First Order Scaling
 - WFE & LOS Stability is proportional to frequency².
 - 3.3X increase in frequency response = 10X improvement in stability
 - WFE & LOS Stability is proportional to acceleration.
 - 1X decrease in acceleration force = 1X improvement in stability
 - WFE & LOS Stability is proportional to mass. (Mass Dampening)
 - 1X increase in mass = 1X improvement in stability

Design for Stability

Wavefront and Line of Sight Stability has design consequences.

- Thermal
 - PM & SM Mirror CTE – want small and very homogeneous
 - Structure CTE – want small and very homogeneous
 - Passive Thermal Isolation - mass
 - Active Thermal Control – predictive thermal control

Telescope Structure:

Predicted LOS Performance

Dynamic Analysis

To determine OTA dynamic opto-mechanical performance:

- Construct a finite element model of the OTA structure.
- Expose model to expected mechanical disturbances:
 - JWST Reaction Wheel Specification
- Calculate Rigid Body motions of SM and PM relative to OTA coordinate system and relative to each other
 - X-, Y-, Z-despace
 - X-, Y-, Z-rotation
- Are Rigid Body motions less than Specification?
- Apply Vibration Isolation:
 - JWST 1-Hz Passive Vibration Isolation
 - Active Isolation
 - Micro-Thrusters

Mechanical Disturbance Input

JWST reaction wheel specification is input into spacecraft at 4 points for standard pyramid arrangement.

This is very conservative worst case.

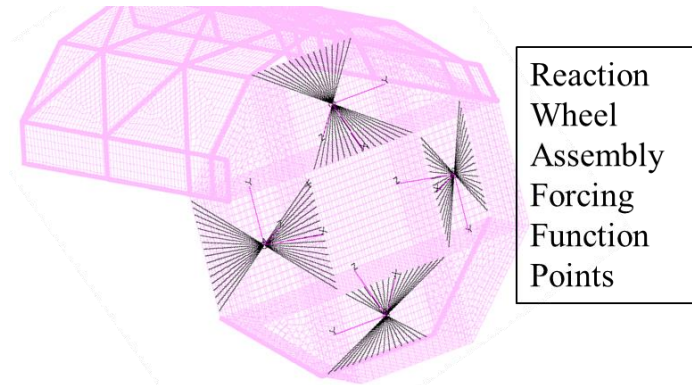

- Radial force and moment disturbances are applied in 10 degree increments around wheel rotation axis. Result is 144 load cases.
- Radial force and moment disturbances are swept through 360 degree wheel rotation to calculate maximum relative displacement between primary and secondary mirror for each wheel.
- **Critical Damping is set at 0.05%**
- **MUF of 4X for > 20 Hz; MUF of 2X for < 20 Hz.**

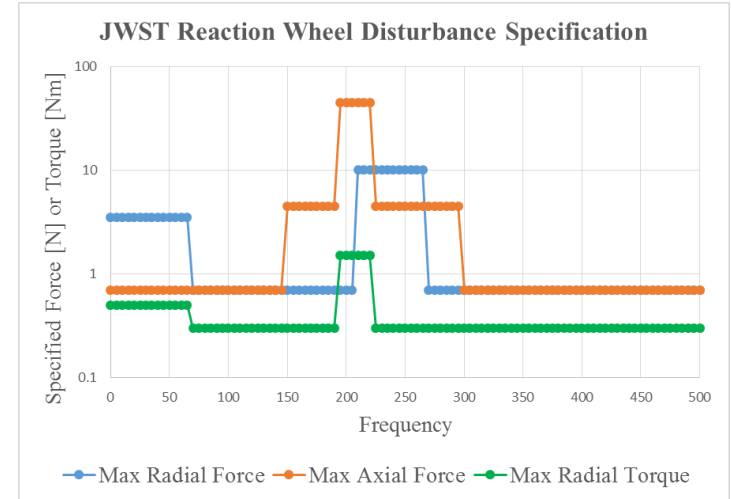

3.3.1.6 Wheel Unbalance

After exposure to the environments defined in section 3.2.5 of this specification, the unbalance magnitude of the RWA rotating components shall not exceed the following values:

- Static Unbalance: Less than 1.0 (g-cm) over the operating speed range.
- Dynamic Unbalance: Less than 14.0 (g-cm²) over the operating speed range.
- The peak radial forces and moments produced by the RWA at any operating speed (including resonant conditions) shall not exceed the values listed in the table below:

Peak Radial Disturbance Limits Including Resonant Conditions					
Parameter	Frequency	Max. Limit	Parameter	Frequency	Max. Limit
Force (F _x)	0-70 Hz	3.5 N	Torque (M _x)	0-70 Hz	0.5 N-m
	70-210 Hz	0.7 N		70-195 Hz	0.3 N-m
	210-270 Hz	1.0 N		195-225 Hz	1.5 N-m
	270-500 Hz	0.7 N		225-500 Hz	0.3 N-m

3.3.1.7 Axial Induced Vibration

The peak force (amplitude) produced by the RWA in the direction parallel to the its spin axis shall not exceed 0.2 N within the frequency range 2-200 Hz, when measured at constant speeds that are within the operational speed range and that are free of major structural resonances. The peak axial force produced by the RWA at any operating speed (including resonant conditions) shall not exceed the following limit values:

Frequency Range (in Hz):	0-150	150-195	195-225	225-300	300-500
Axial Force (F _z) Limit:	0.7 N	4.5 N	4.5 N	4.5 N	0.7 N

PM/SM Rigid Body Motion vs Disturbance

- PM, SM motion (**relative to Fold Mirror**) is calculated using MPC (NASTRAN Multi Point Constraint).
- **Motions are reported in a local optical coordinate system:**
 - PM in CS13,
 - SM in CS12 and
 - **Relative PM/SM in CS11.**
- Material properties based on quasi-isotropic M46J

Tension	
0 degrees, *Et1	(Msi) 13.55101
90 degrees, *Et2	(Msi) 13.55101
Poisson's Ratio, *vt12	0.314294

M46J Quasi-Isotropic Laminate Properties
 (25%0, 50%45, 25%90)
 Density = 1.58 gram/cm³ (0.057 lb/in³)

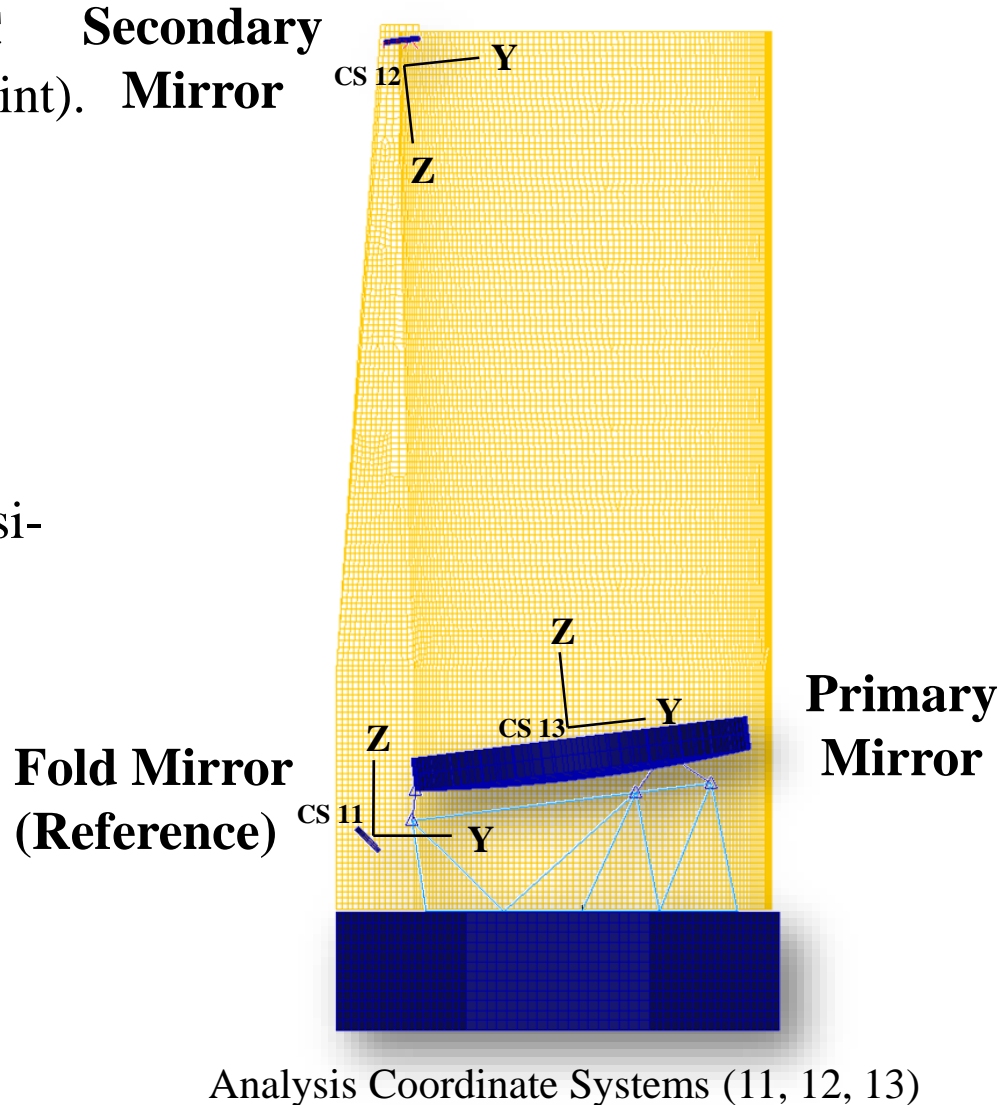

Analysis Coordinate Systems (11, 12, 13)

28 Hz Telescope Tube Bending Mode moves both SM and PM

Patran 2014.1 64-Bit 08-Nov-17 12:32:20

Deform: NM, Mode 1:Freq.=28.136, Eigenvectors, Translational,

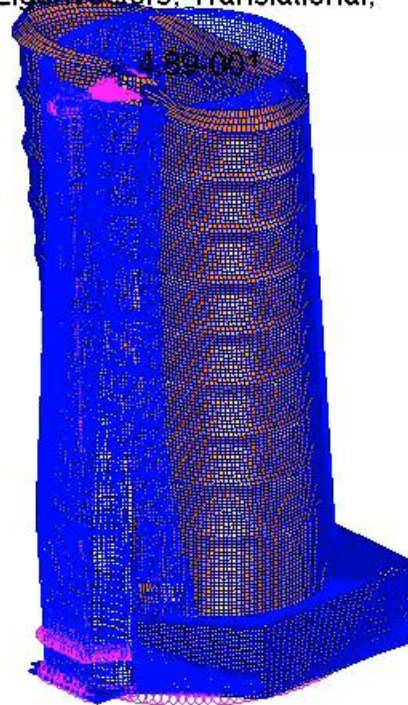

default_Deformation :
Max 4.89-001 @Nd 42558:
Frame: 1
Scale = 1.00+000

28 Hz Mode (JWST Disturbance)

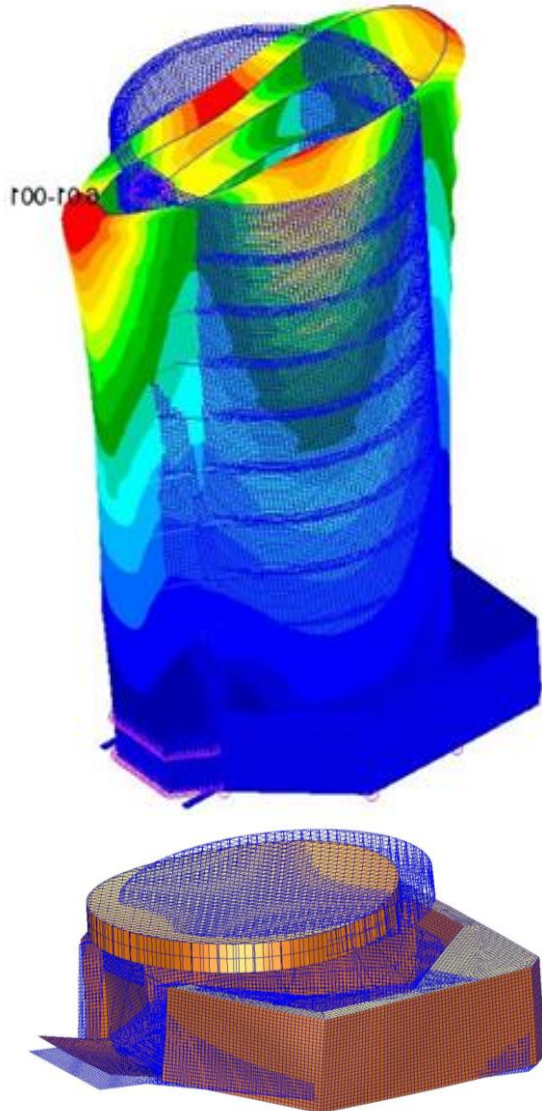

SM motion:

- $\Delta X = 320 \text{ nm}$
- $\Delta Y = 9,550 \text{ nm}$
- $\Delta Z = 260 \text{ nm}$
- $\Theta X = 84 \text{ nrad}$
- $\Theta Y = 2 \text{ nrad}$
- $\Theta Z = 16 \text{ nrad}$

PM motion:

- $\Delta X = 360 \text{ nm}$
- $\Delta Y = 18,400 \text{ nm}$
- $\Delta Z = 6,500 \text{ nm}$
- $\Theta X = 62 \text{ nrad}$
- $\Theta Y = 1 \text{ nrad}$
- $\Theta Z = 1 \text{ nrad}$

69 Hz Bus Modes (JWST Disturbance)

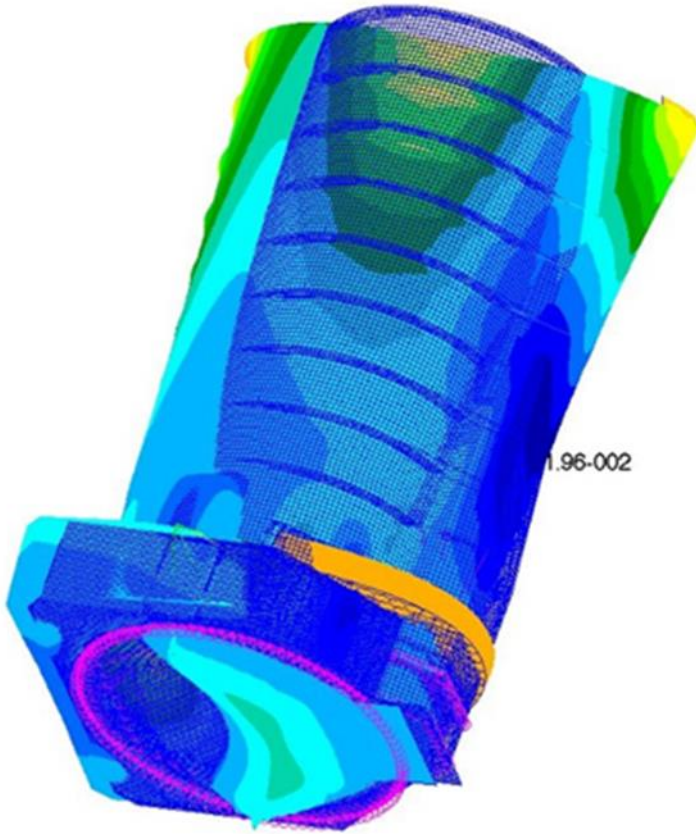

SM motion:

- $\Delta X = 4,840$ nm
- $\Delta Y = 27,600$ nm
- $\Delta Z = 3,150$ nm
- $\Theta X = 189$ nrad
- $\Theta Y = 20$ nrad
- $\Theta Z = 63$ nrad

PM motion:

- $\Delta X = 7,560$ nm
- $\Delta Y = 1,390$ nm
- $\Delta Z = 2,090$ nm
- $\Theta X = 8$ nrad
- $\Theta Y = 28$ nrad
- $\Theta Z = 80$ nrad

Secondary Mirror Rigid Body Motion

SM first mode motion relative to Fold Mirror:

- $\Delta X = 300$ nm at 28 Hz
- $\Delta Y = 10,000$ nm at 28 Hz
- $\Delta Z = 200$ nm at 28 Hz
- $\Theta X = 84$ nrad at 28 Hz
- $\Theta Y = 2$ nrad at 28 Hz
- $\Theta Z = 16$ nrad at 28 Hz

All larger than LOS tolerances:

- $\Delta X = 4$ nm
- $\Delta Y = 4$ nm
- $\Delta Z = 8$ nm
- $\Theta X = 0.5$ nrad
- $\Theta Y = 0.5$ nrad
- $\Theta Z = 0.5$ nrad

Need Vibration Isolation

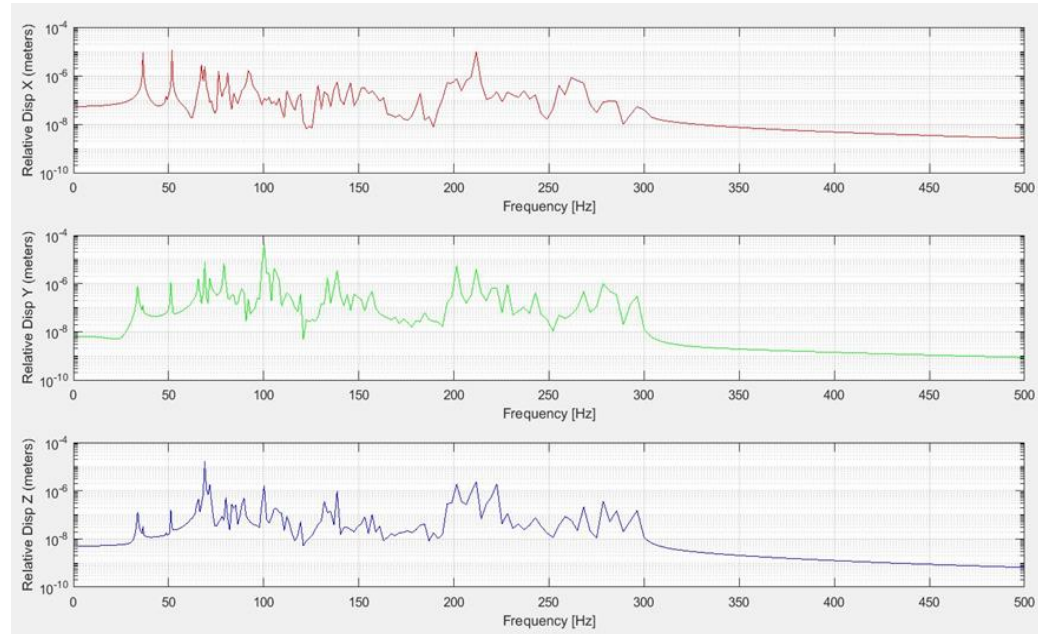

Primary Mirror Rigid Body Motion

PM first mode motion relative to Fold Mirror:

- $\Delta X = 11,500$ nm at 34 Hz
- $\Delta Y = 18,400$ nm at 28 Hz
- $\Delta Z = 6,500$ nm at 28 Hz
- $\Theta X = 62$ nrad at 28 Hz
- $\Theta Y = 39$ nrad at 34 Hz
- $\Theta Z = 43$ nrad at 34 Hz

Are larger than LOS tolerances:

- $\Delta X = 4$ nm
- $\Delta Y = 4$ nm
- $\Delta Z = 8$ nm
- $\Theta X = 0.25$ nrad
- $\Theta Y = 0.25$ nrad
- $\Theta Z = 0.5$ nrad

Need Vibration Isolation

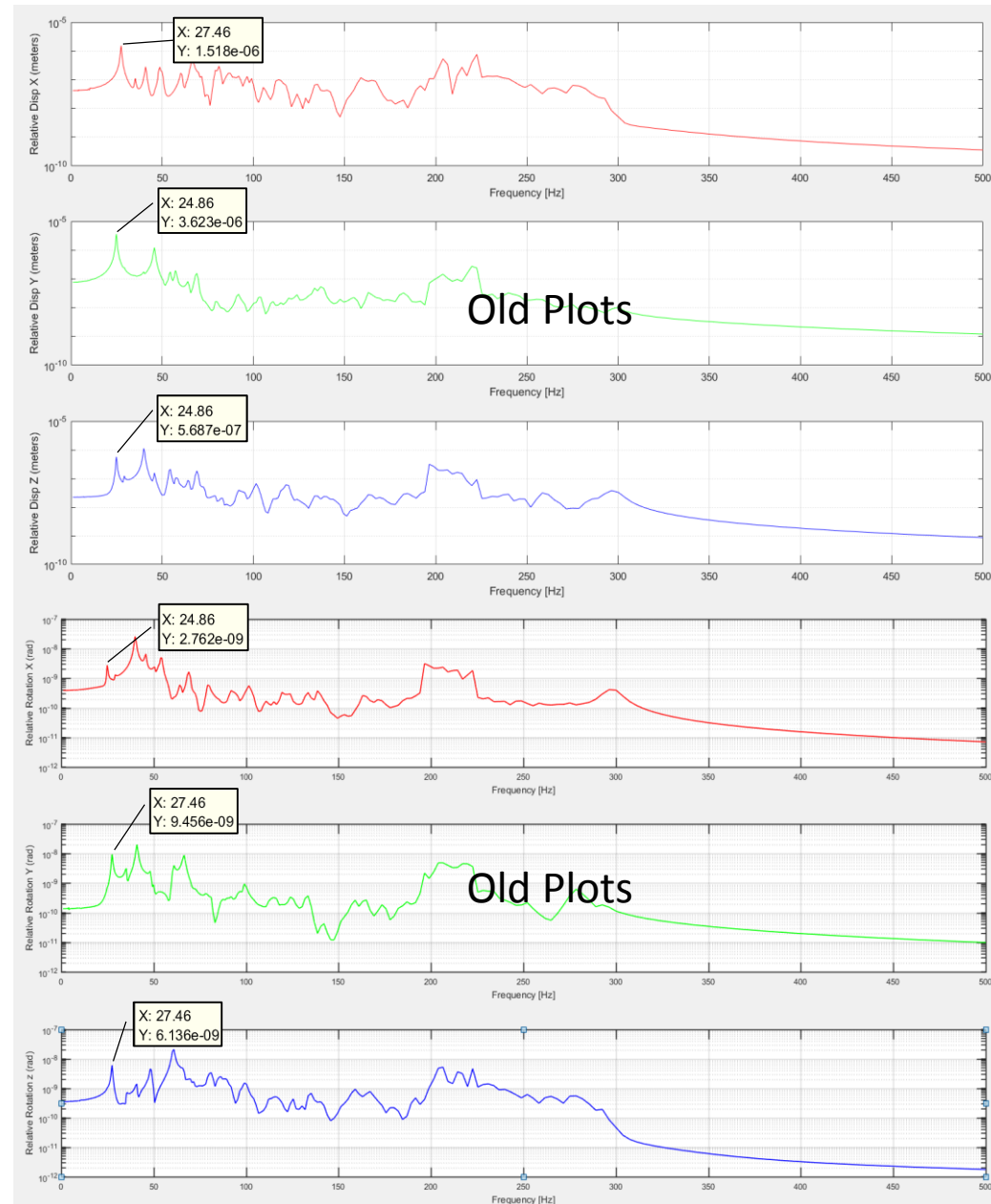

Telescope Structure LOS Stability: PM Tolerances

Motions induced by a JWST RWA Mechanical Disturbance
Spectrum exceeds the LOS Tolerances (red lines)

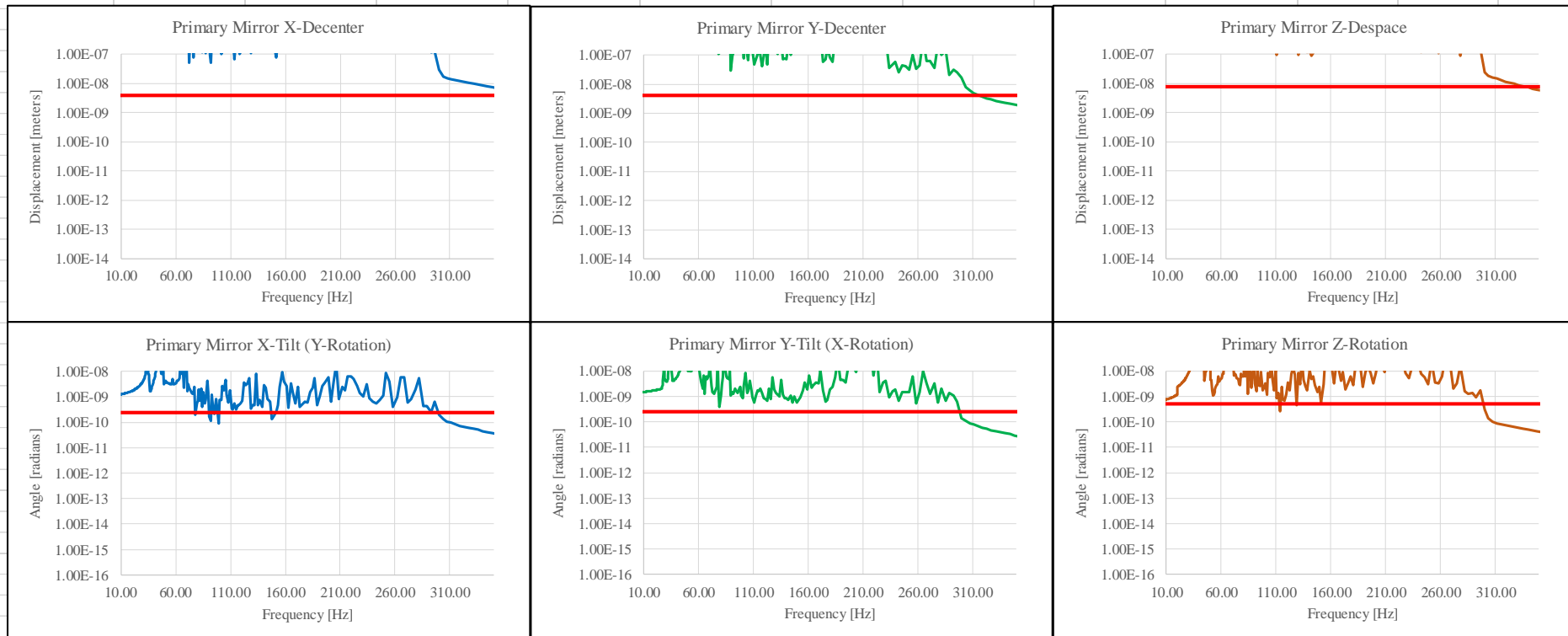

Vibration Isolation

JWST has 2 passive stages producing 70dB of isolation:

- 8-Hz between reaction wheels & spacecraft.
- 2-Hz between spacecraft and OTA.

Passive Isolation

- $\sim 10\text{dB/octave}$
- Damping is important

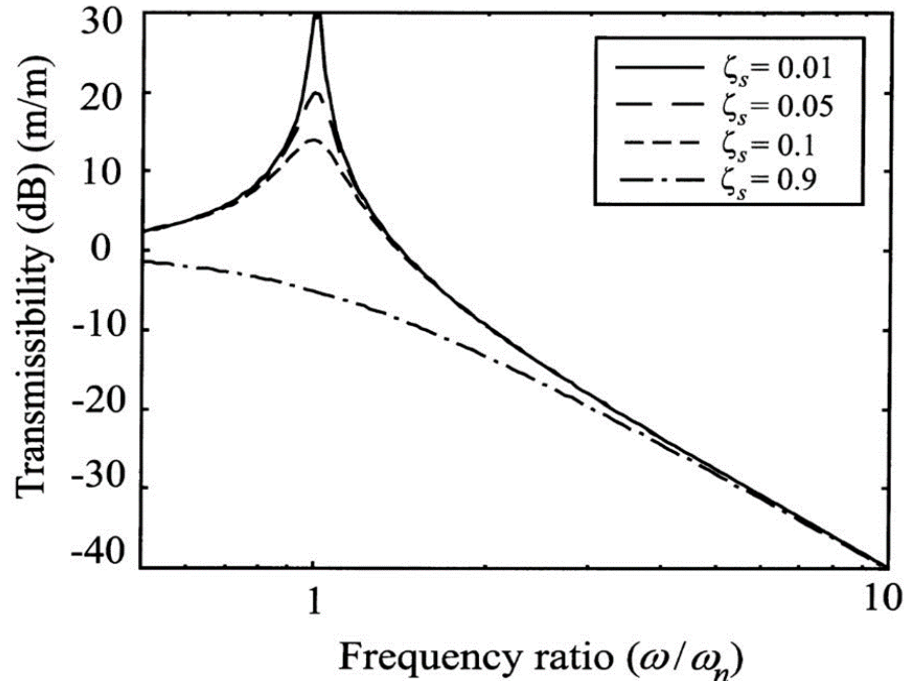

JWST Isolation

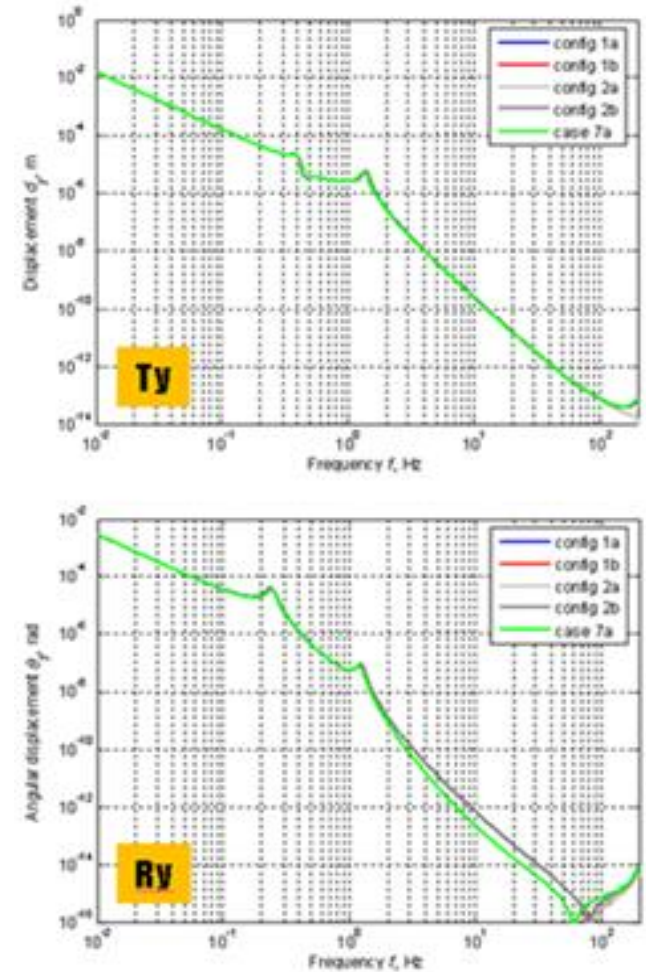

Passive vs Active Vibration Isolation

Theoretical Isolation Filters:

- Passive = 1 Hz, 10% damping
- Active = 40 dB initial reduction, 0.8 Hz, 10% damping
- Micro-Thrusters initial 60 dB reduction, 2 Hz 50% damping

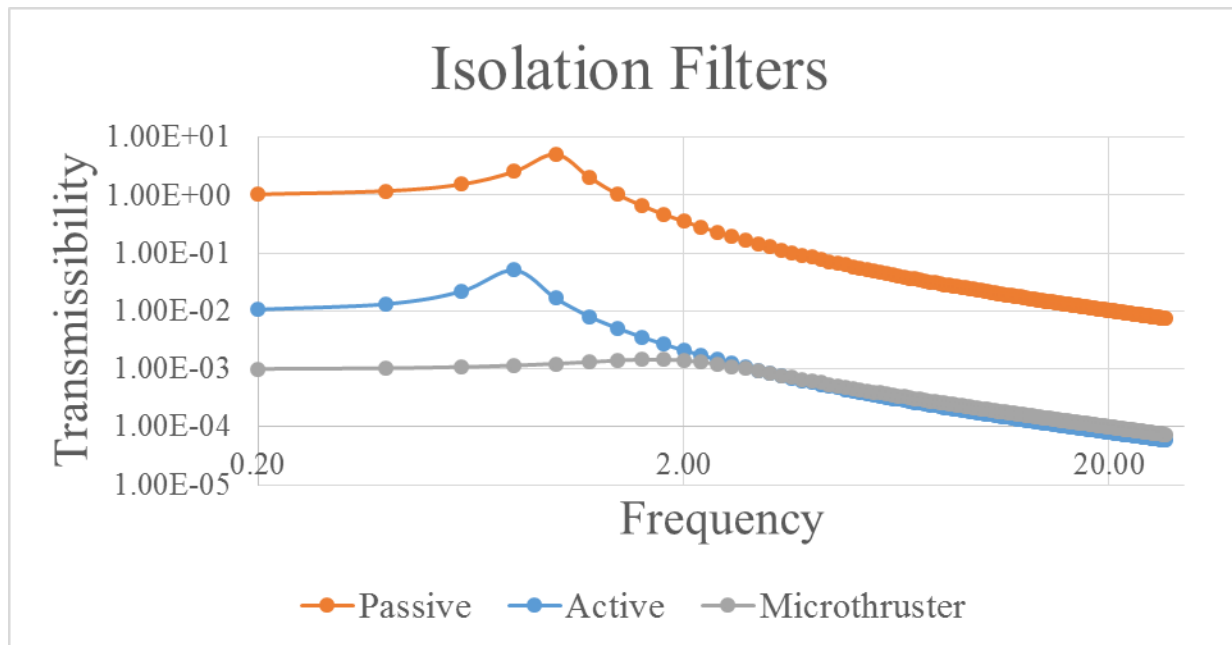

Telescope Structure LOS Stability: PM Tolerances

Passive JWST 2-stage vibration isolation does not achieve requirements.

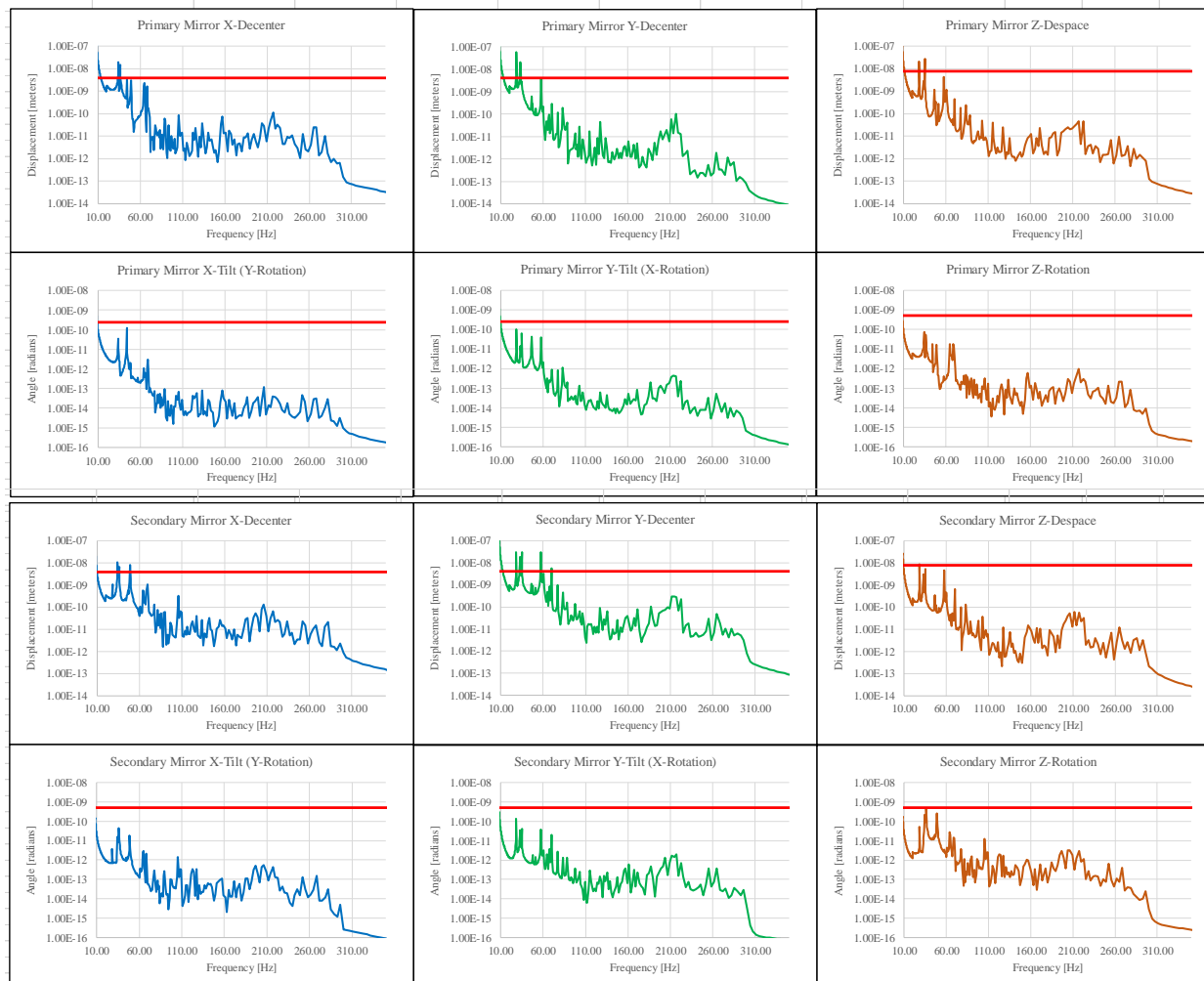

Telescope Structure LOS Stability: Tolerances

Single stage of active isolation almost achieves requirements.

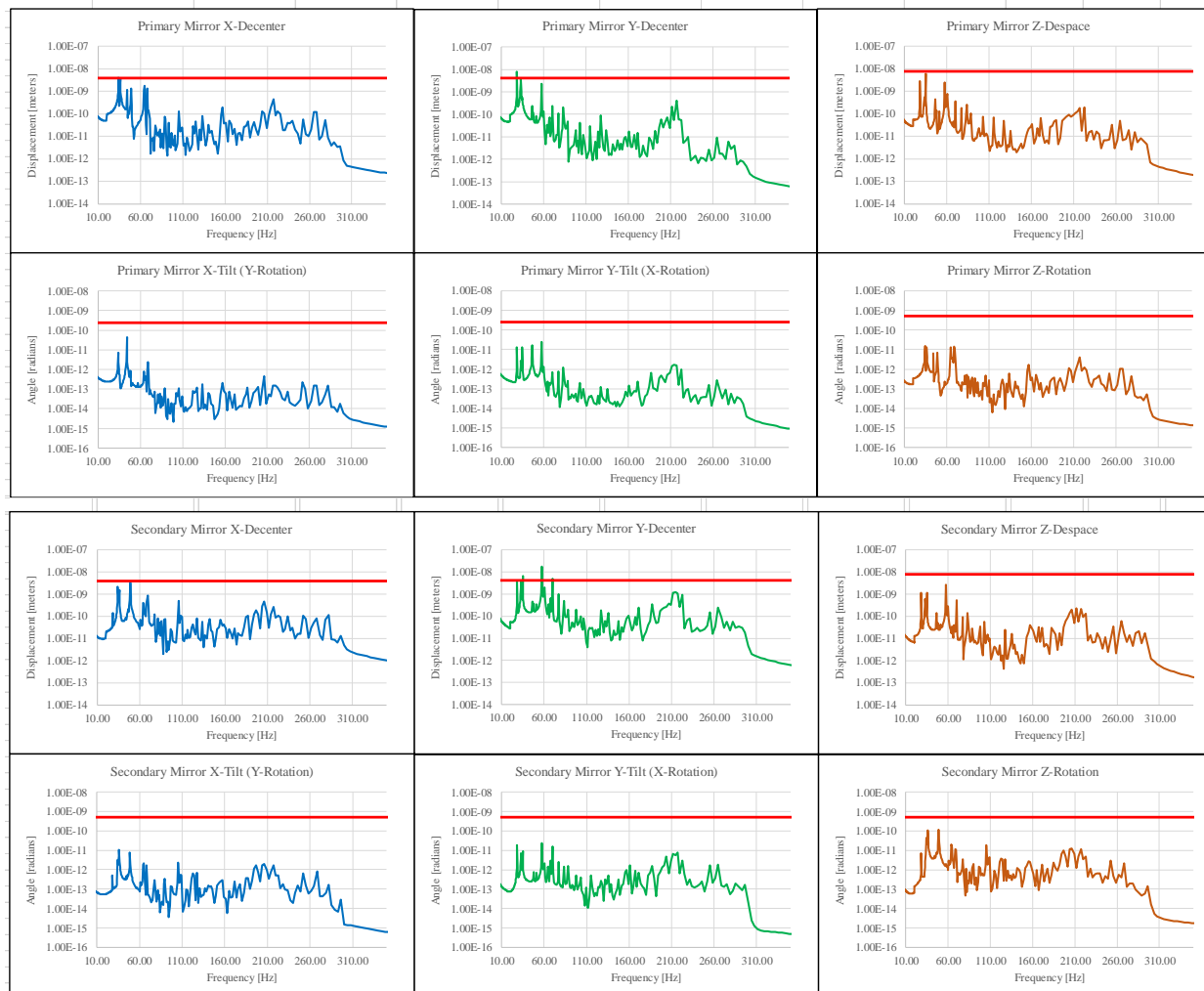

Telescope Structure LOS Stability: Tolerances

Replacing reaction wheels with micro-thrusters allows baseline telescope to achieve rigid body motion tolerances required for LOS and WFE stability.

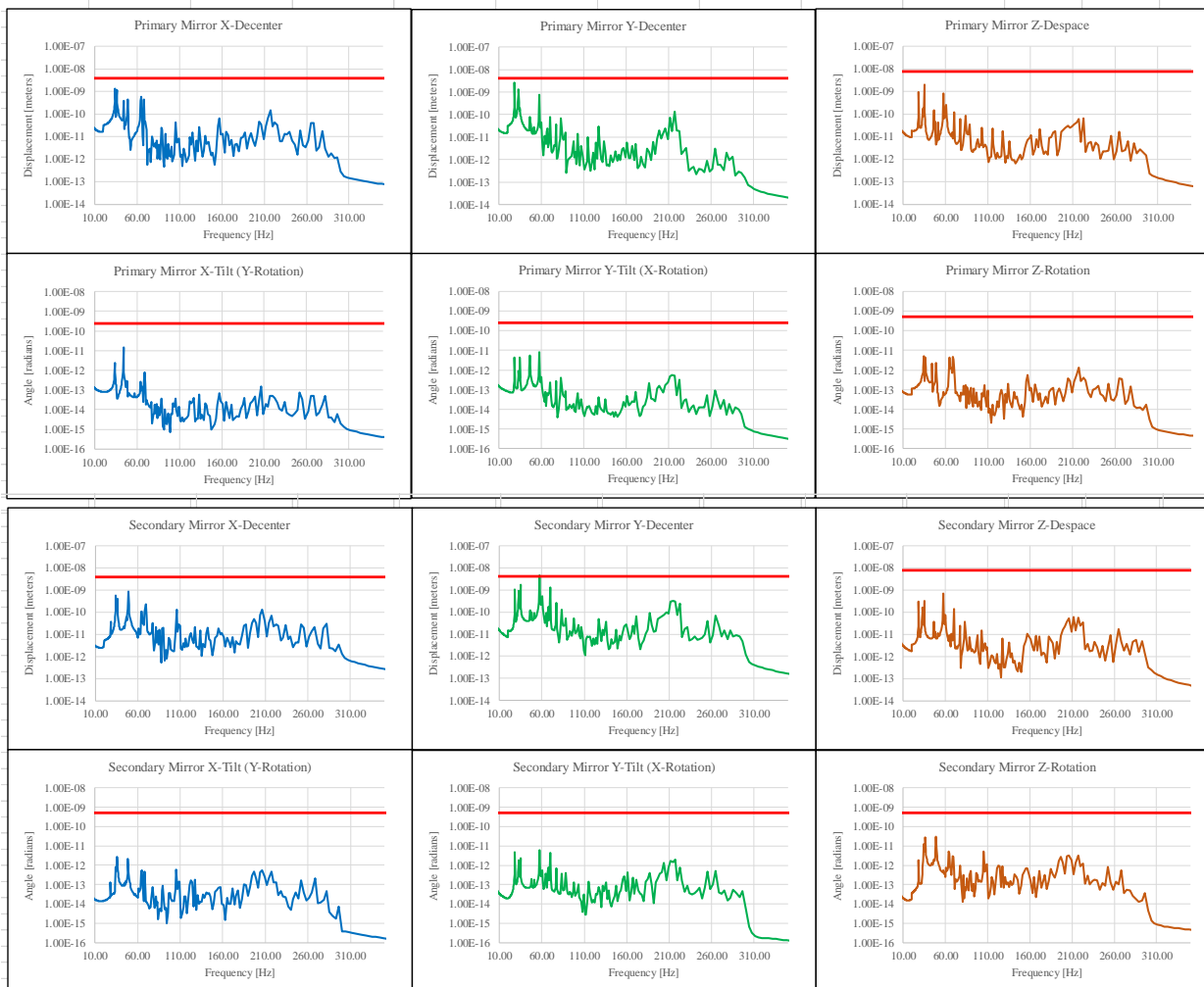

Dynamic Wavefront Error:

Mechanical Stability

Primary Mirror Dynamic Wavefront Error

Dynamic PM WFE arises from two sources:

- Mechanical
- Thermal

Mechanical Vibrations have a temporal spectrum:

- Specific vibration frequencies induce harmonic modal response.
- All other vibration frequencies cause inertial response.

These responses produce structural motions that cause:

- Optical mis-alignment aberrations
- Optical component bending and deformations from mount stress

Primary Mirror Dynamic WFE

PM Dynamic Error is proportional to Gravity Sag.

- 1 G acceleration = 1 Gravity Sag
- 1 μ G acceleration = 1 μ _Gravity Sag

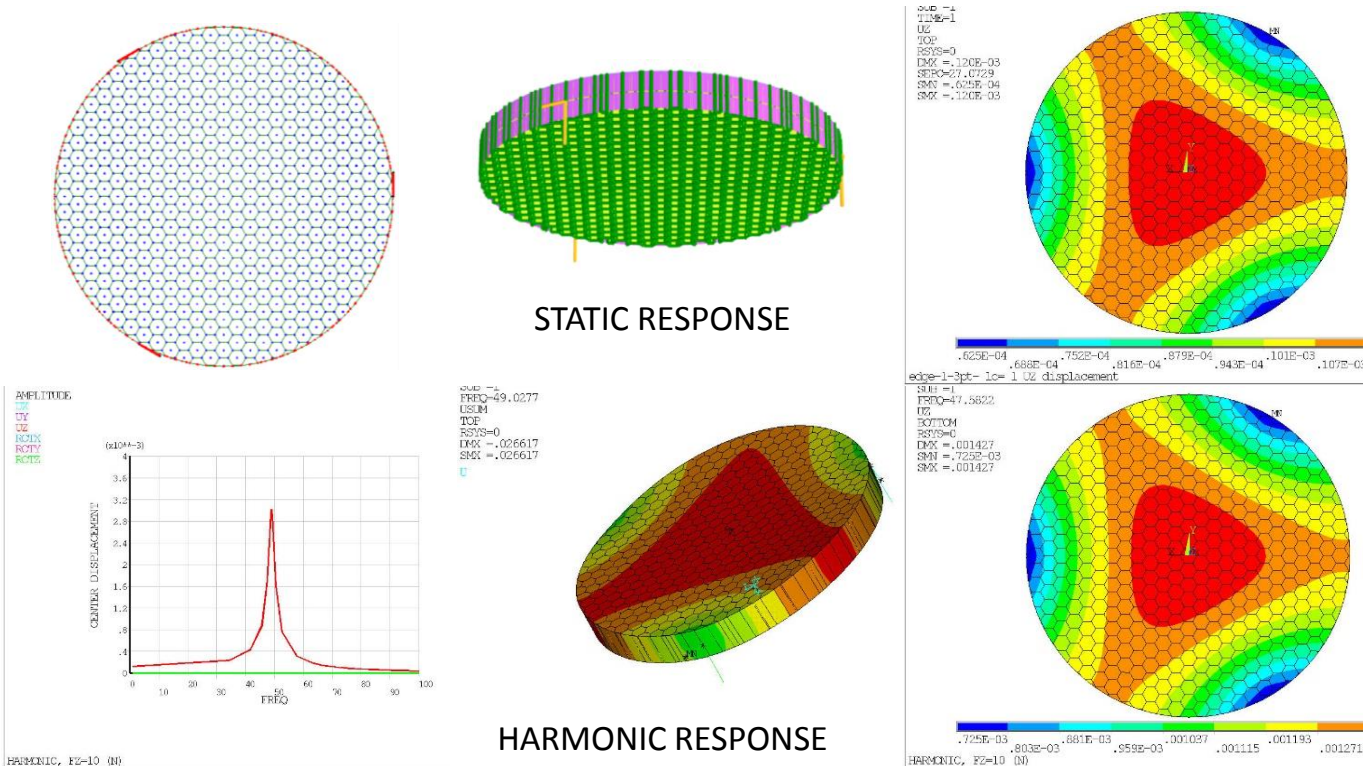

Primary Mirror Dynamic WFE

To minimize PM Dynamic WFE:

- Design the PM Substrate to be as stiff as possible
- Consider number of Mount Points
- Consider the Mount stiffness and location.

Mounts with more support points have less Gravity Sag.

3-Point Mounts will have a Trefoil Signature.

- If Trefoil Gravity sag is 60 micrometers
- And, if Coronagraph requires < 6 pm of Trefoil
- Then mirror acceleration must remain $< 1 \mu\text{N}$

If Coronagraph is sensitive to Trefoil, consider a 6-point Mount.

Gravity Sag vs Mount Support Points

The more mounts support points, the smaller the gravity sag.
And, the smaller the Dynamic WFE.

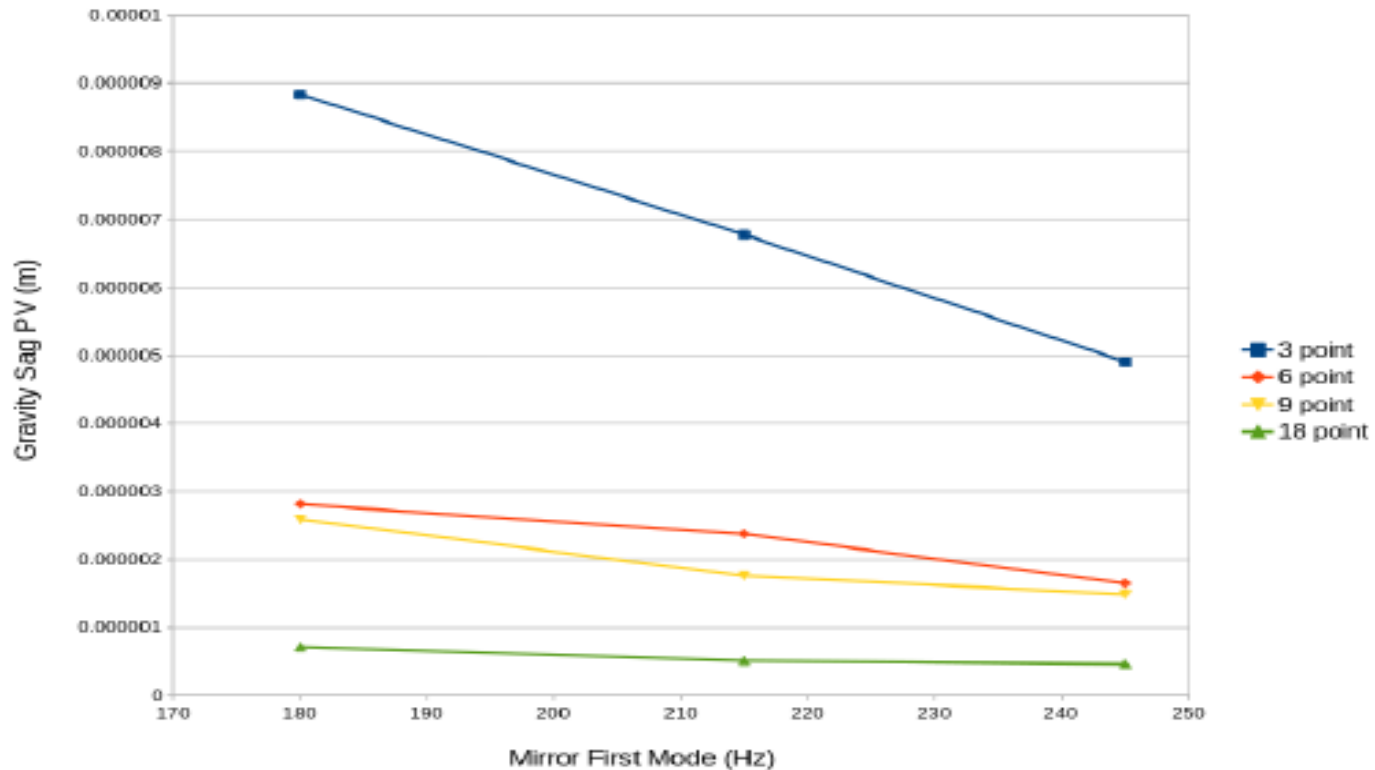

Plot is for a 180 Hz closed-back ULE mirror.

Dynamic WFE vs Mirror Support Mount

Different mount designs (for 3-point or 6-point mounts attached at the mirror's edge, 80% or 65% radius) produce different dynamic WFE.

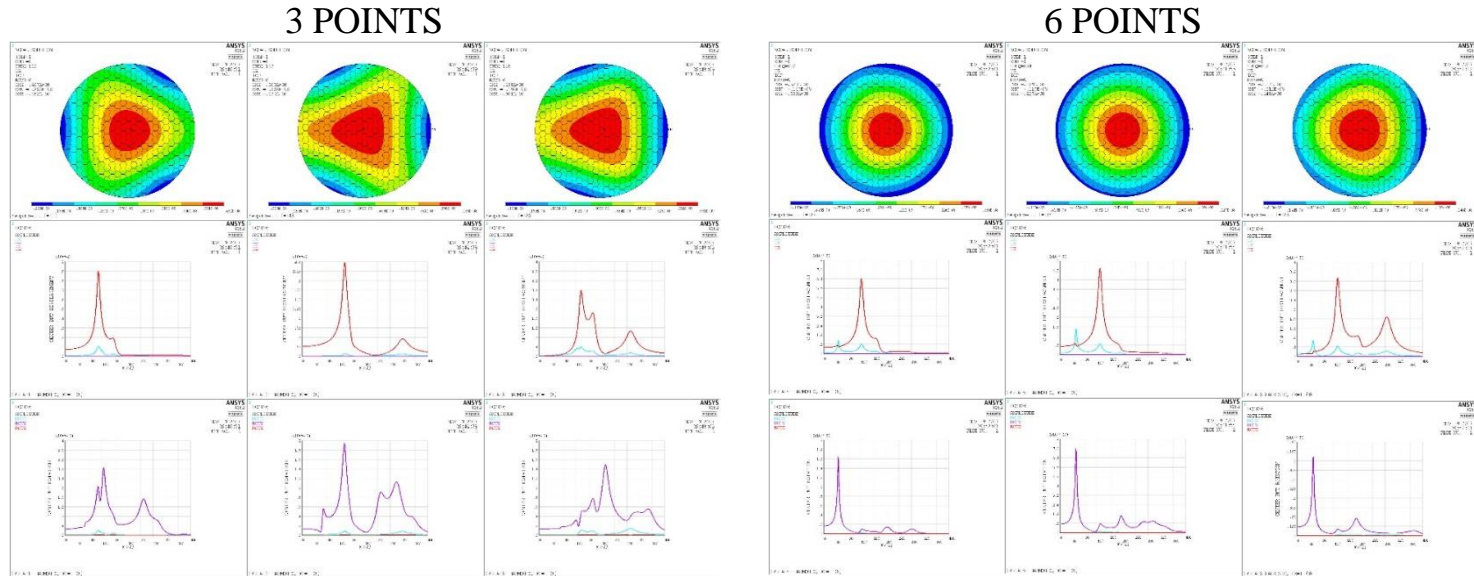

For baseline Flat-Back, Open-Back, Straight-Rib Zerodur 4-m mirror with 1652 kg being driven by 1 N harmonic force from 1 to 400 Hz against a 10,000 kg observatory mass.

<u>Location</u>	<u>3 point</u>	<u>6 point</u>
95%	1.071 nm rms at 88 Hz	0.812 nm rms at 105 Hz
80%	0.725 nm rms at 127 Hz	0.599 nm rms at 119 Hz
65%	0.303 nm rms at 165 Hz	0.574 nm rms at 108 Hz

For 0.0001 N Micro-Thrusters, dynamic WFE is less than picometer rms.

Max WFE Distortion vs Flexure Stiffness

Maximum dynamic WFE is proportional to flexure stiffness between the mirror and its support system.

For Micro-Thrusters of 0.0001N, dynamic WFE is negligible.

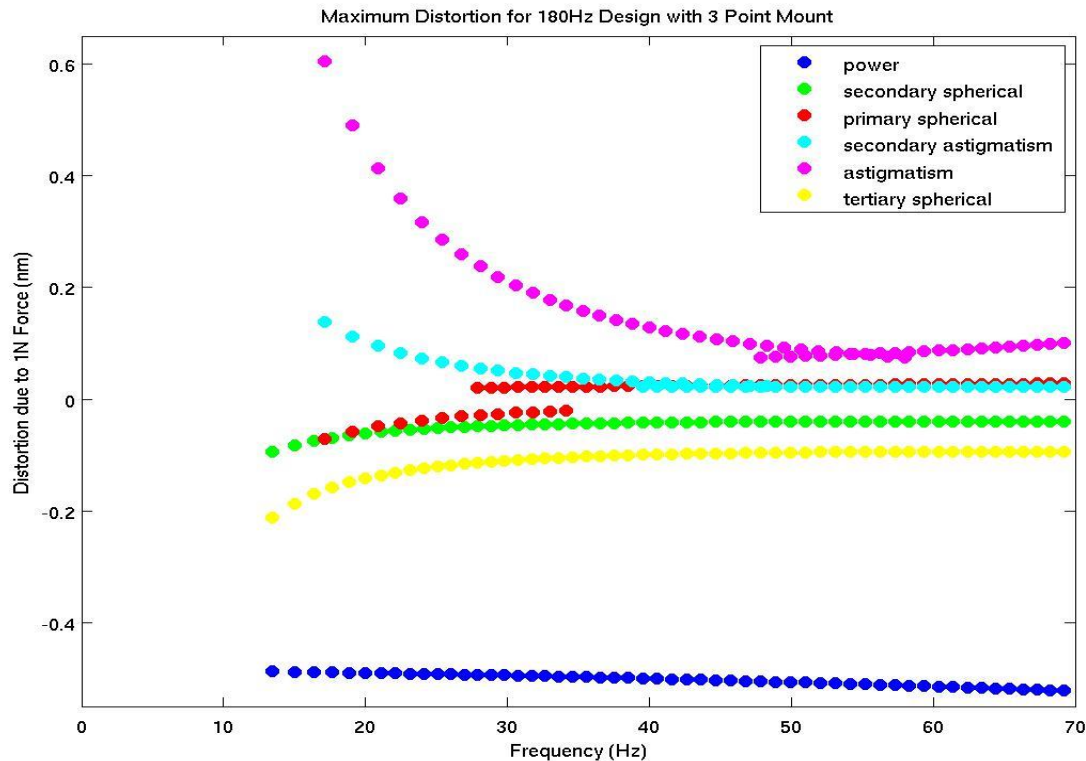

Plot is for a 180 Hz closed-back ULE mirror.

Primary Mirror Dynamic WFE State-of-Art

JWST's 220-Hz open-back beryllium primary mirror segments on a 3-point mount have a static horizontal G-sag of approximately 200 nm.

When driven at 87.3 Hz, they have a dynamic Astigmatic WFE of 220 nm per G of driving force.

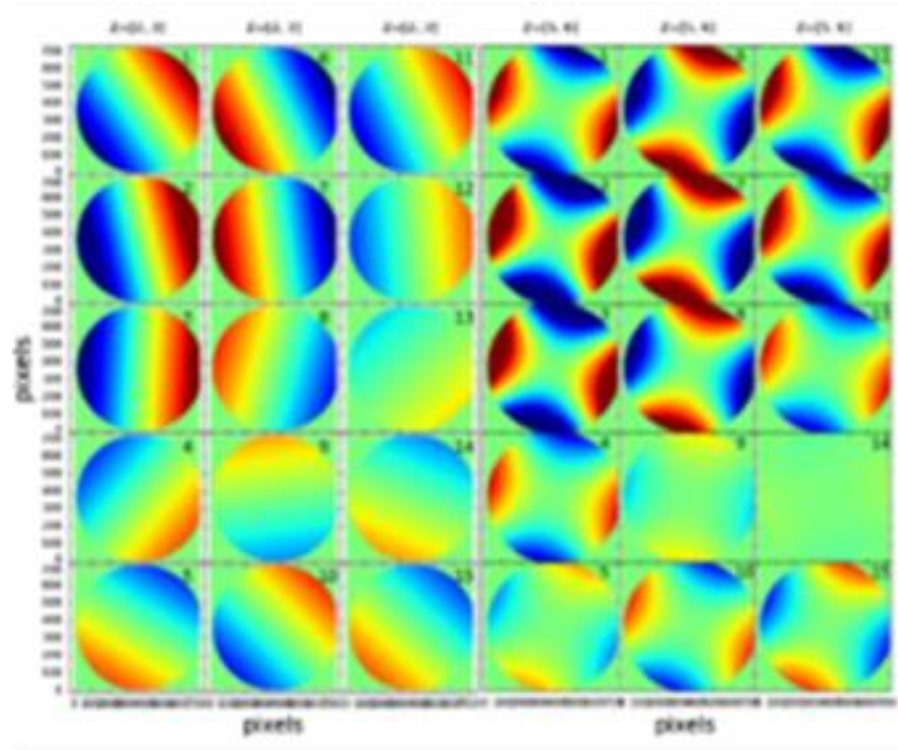

Saif, et. al., Nanometer level characterization of the James Webb Space Telescope optomechanical systems using high-speed interferometry, Applied Optics, Vol.54, No.13, pg.4295, doi:134285-14, 2015

Primary Mirror Assembly

Baseline PMA is open-back 4.2 x 0.42-m 1650 kg Zerodur substrate on 3 point hexapod mount attached to truss.

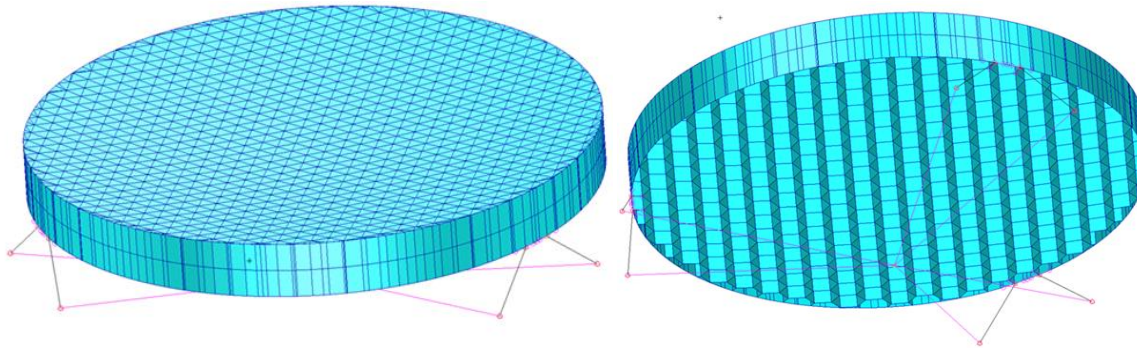

Primary Mirror Substrate Free-Free Modes:

1st Bending Mode at 80.7 Hz

2nd Bending Mode at 181.4 Hz

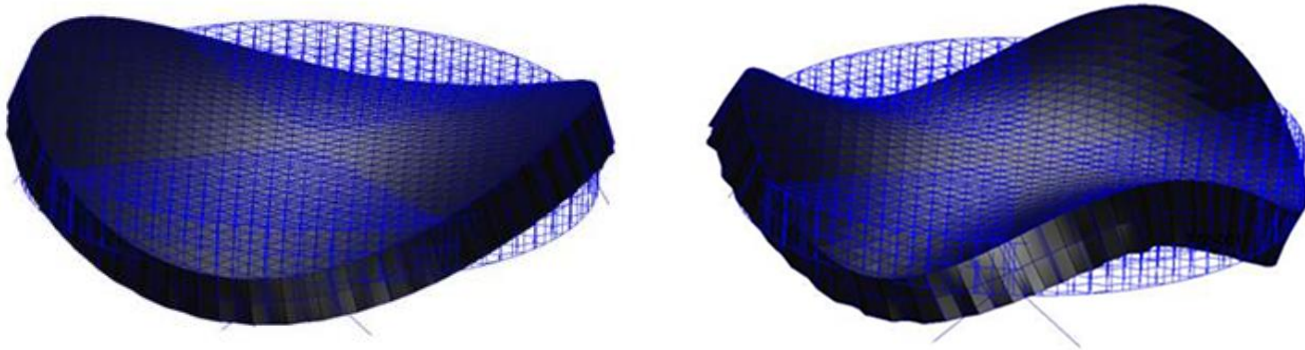

First 'mounted' bending mode is at 65.2 Hz.

Primary Mirror Assembly Dynamic WFE

Predicted Gravity Sag of baseline 80 Hz open-back Zerodur 4-m off-axis primary mirror on 3 point mount is $62 \mu\text{m PV}$

Dynamic WFE depends on mode and driving force.

Gravity Sag = $62 \mu\text{m PV}$

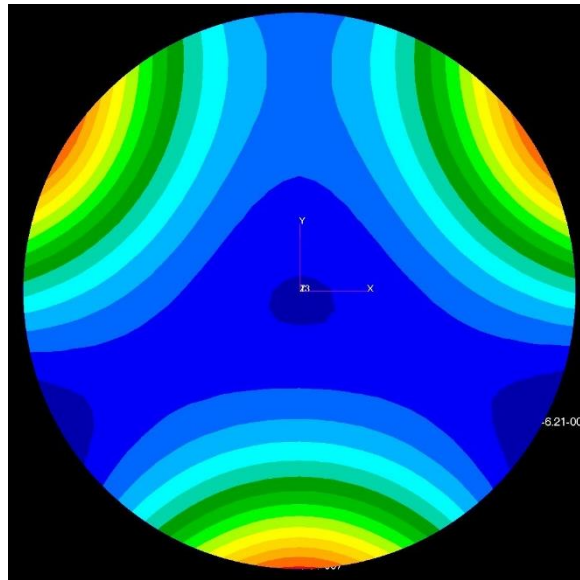

33 Hz PM & Bus Mode - Sliding

Patran 2014.1 64-Bit 08-Nov-17 12:26:09

Deform: NM, Mode 2:Freq.=32.945, Eigenvectors, Translational,

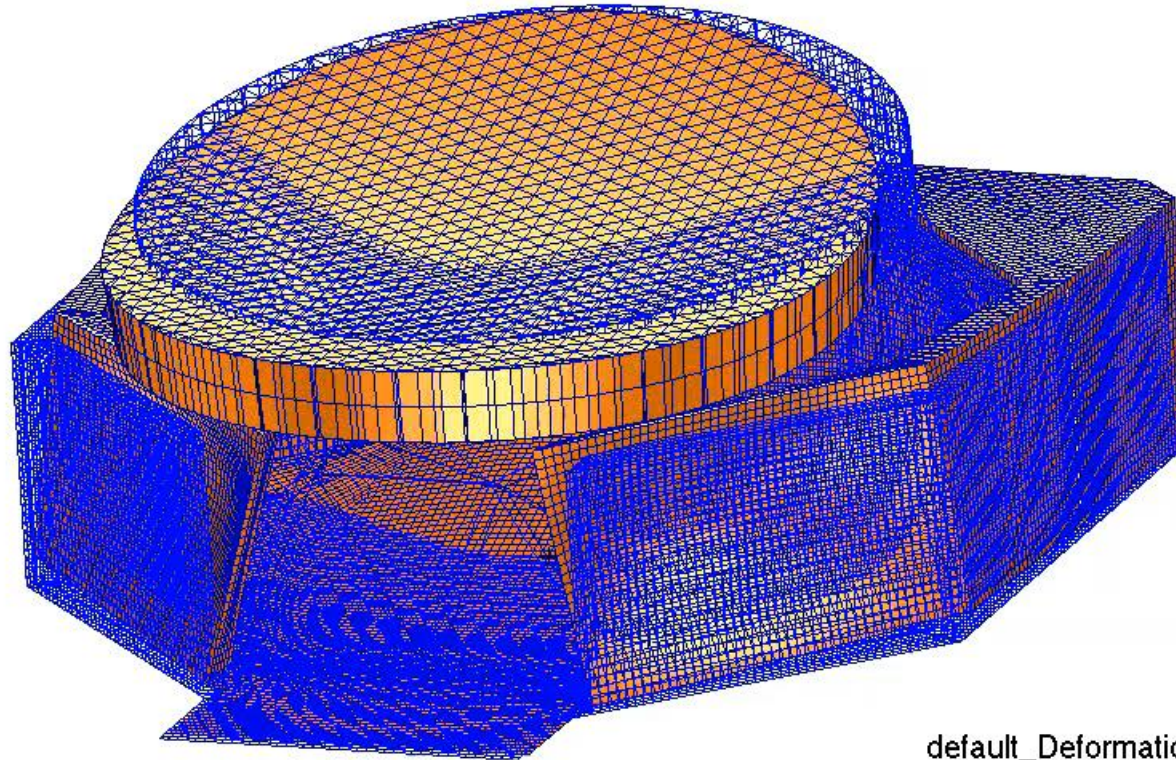

default_Deformation :
Max 2.89-001 @Nd 20007
Frame: 1
Scale = 1.00+000

33 Hz Mode (JWST Disturbance)

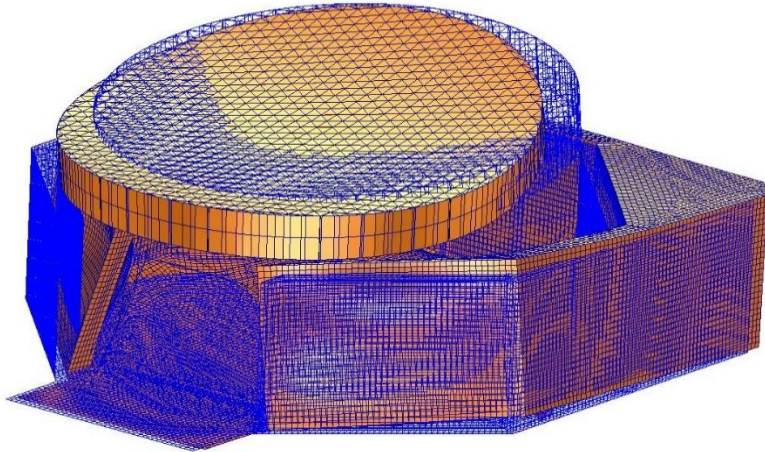

PM motion:

- $\Delta X = 1,050 \text{ nm}$
- $\Delta Y = 2,610 \text{ nm}$
- $\Delta Z = 345 \text{ nm}$
- $\Theta X = 3 \text{ nrad}$
- $\Theta Y = 3 \text{ nrad}$
- $\Theta Z = 4 \text{ nrad}$

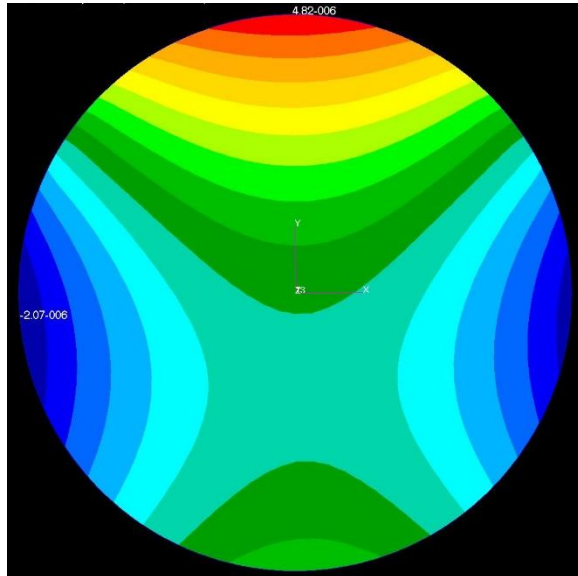

WFE = 7,000 nm PV

Microthrusters will reduce dynamic WFE to $< 10 \text{ pm}$

34 Hz PM & Bus Mode – Sliding & Rocking

Patran 2014.1 64-Bit 08-Nov-17 12:27:37

Deform: NM, Mode 3:Freq.=34.054, Eigenvectors, Translational,

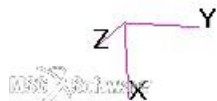
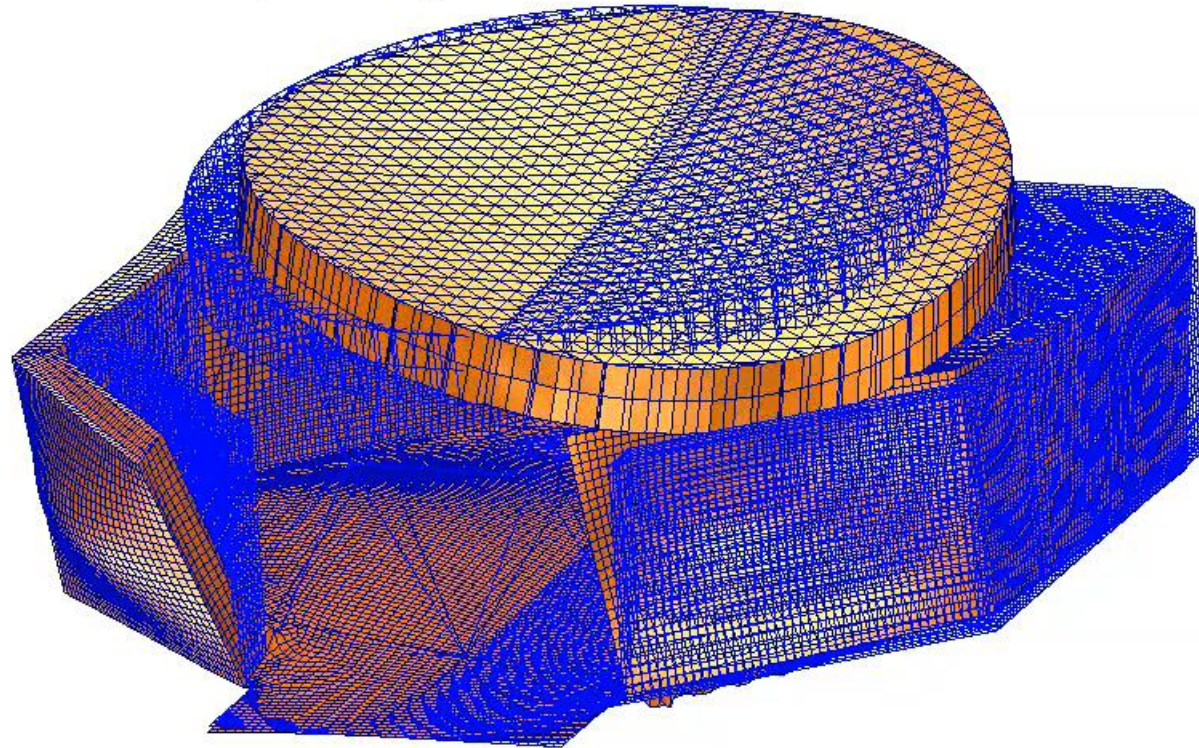

default_Deformation :
Max 3.06-001 @Nd 61001!
Frame: 1
Scale = 1.00+000

34 Hz PM & Bus Mode – Sliding & Rocking

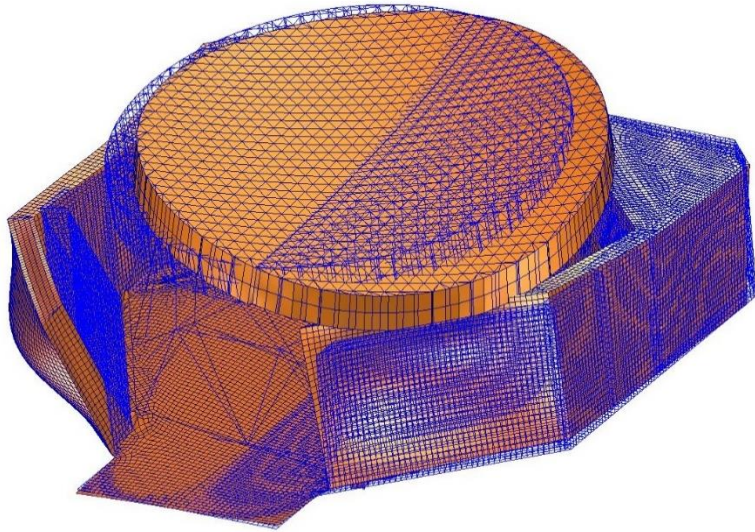

PM motion:

- $\Delta X = 11,500 \text{ nm}$
- $\Delta Y = 1,760 \text{ nm}$
- $\Delta Z = 743 \text{ nm}$
- $\Theta X = 5 \text{ nrad}$
- $\Theta Y = 39 \text{ nrad}$
- $\Theta Z = 43 \text{ nrad}$

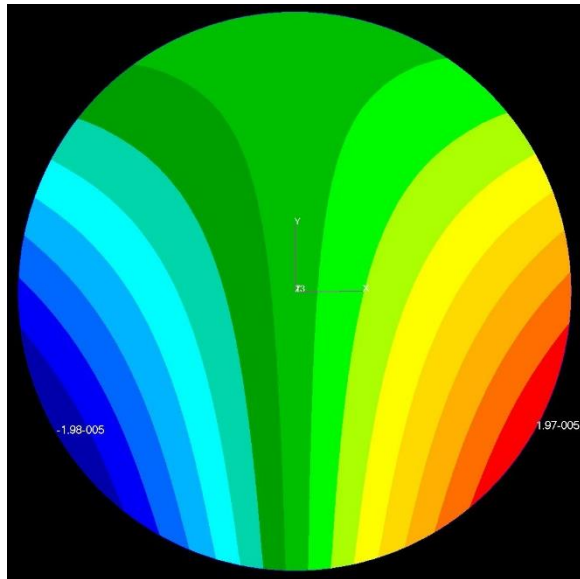

WFE = 40,000 nm PV

Microthrusters will reduce
dynamic WFE to $< 50 \text{ pm}$

(Need to remove Tilt)

44 Hz PM & Bus Mode – Rocking

Patran 2014.1 64-Bit 08-Nov-17 12:23:52

Deform: NM, Mode 6:Freq.=44.061, Eigenvectors, Translational,

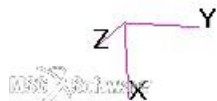
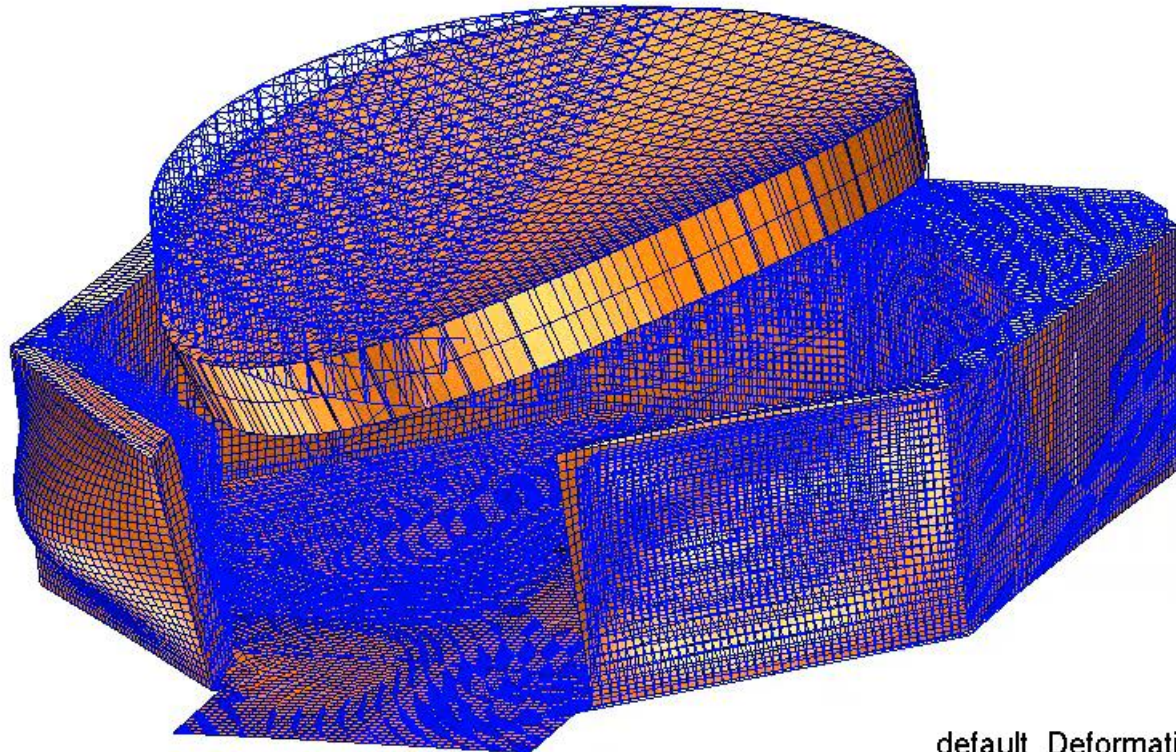

default_Deformation :
Max 6.18-001 @Nd 60997:
Frame: 1
Scale = 1.00+000

44 Hz PM & Bus Mode – Rocking

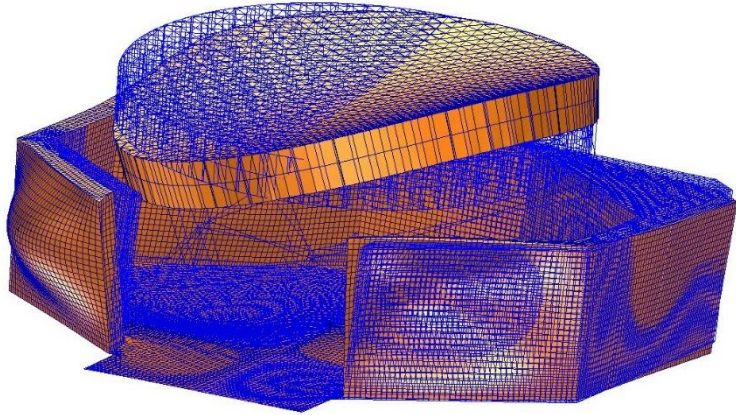

PM motion:

- $\Delta X = 4,230 \text{ nm}$
- $\Delta Y = 220 \text{ nm}$
- $\Delta Z = 15 \text{ nm}$
- $\Theta X = 7 \text{ nrad}$
- $\Theta Y = 330 \text{ nrad}$
- $\Theta Z = 23 \text{ nrad}$

Dynamic Wavefront Error:

Thermal Stability

Thermal changes produce structural and component motions as a result of material response (bulk CTE and CTE homogeneity)

Static Thermal WFE

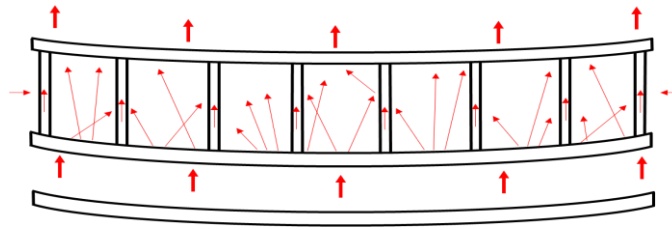

0.5 m thick closed-back ULE mirror
Radial Gradient depends on view factor
and side insulation.

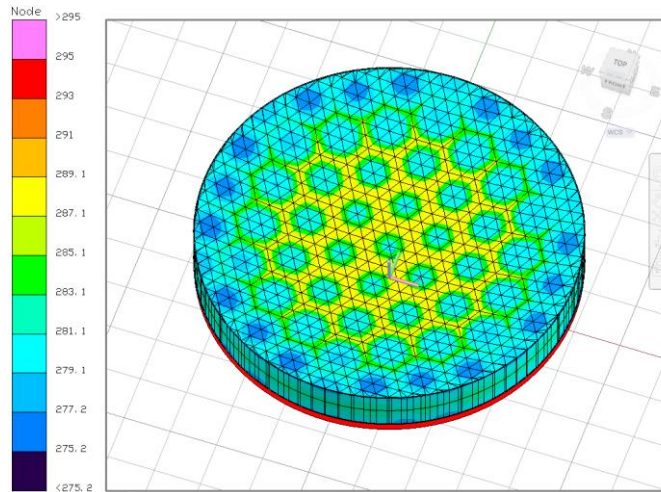

Temperature gradient
Keeping Front Surface > 273K
20C Axial; 10C Radial

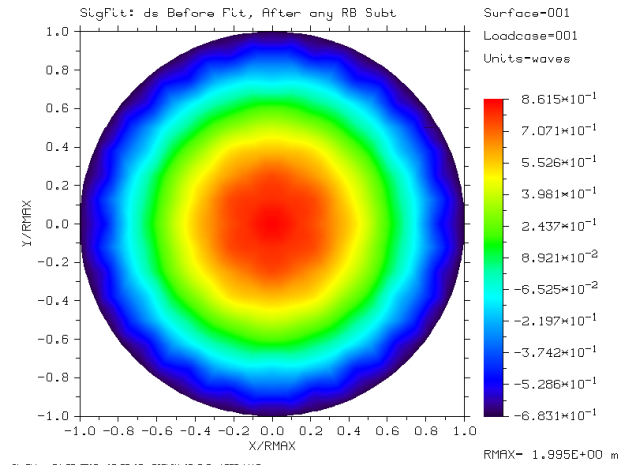
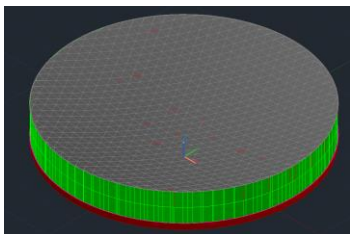
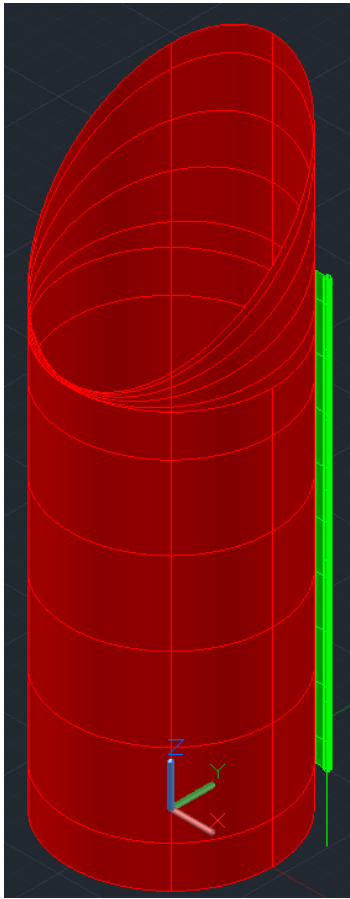

SFE from isothermal with defocus
SFE = 977 nm PV; 288 nm RMS

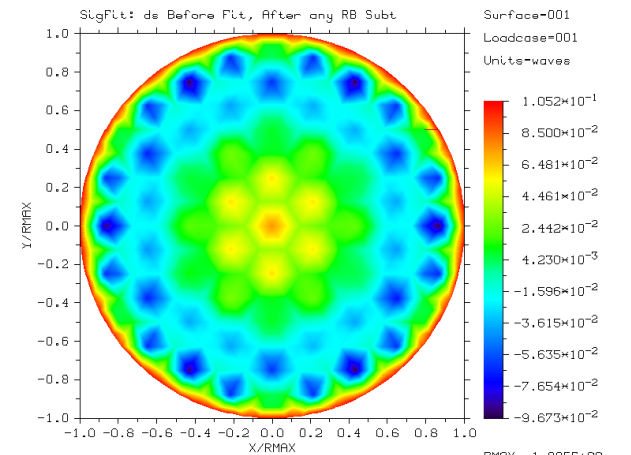

SFE from with defocus removed
SFE = 128 nm PV; 24 nm RMS

Dynamic Thermal WFE Video

Passive Wavefront Error from 1 hour exposure.

Sun angle changes by 0.0411 degree per hour.

All Errors

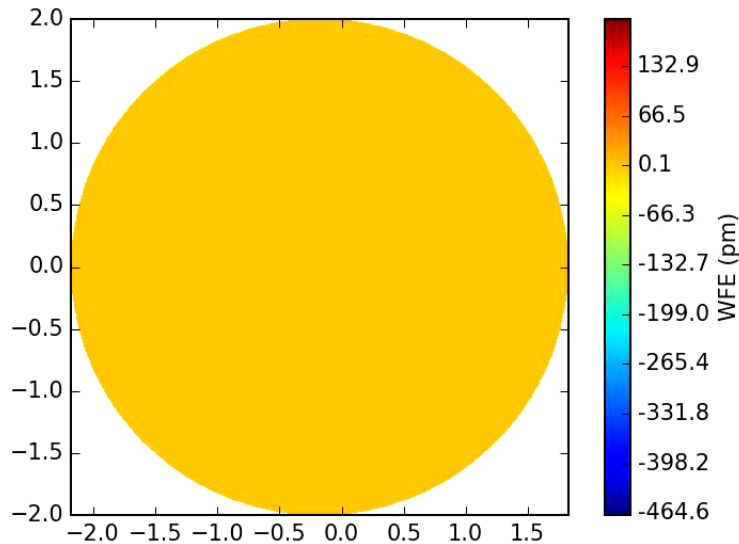

WFE/1-hour = 233 pm PV
WFE/20-min = 28 pm

Power Removed

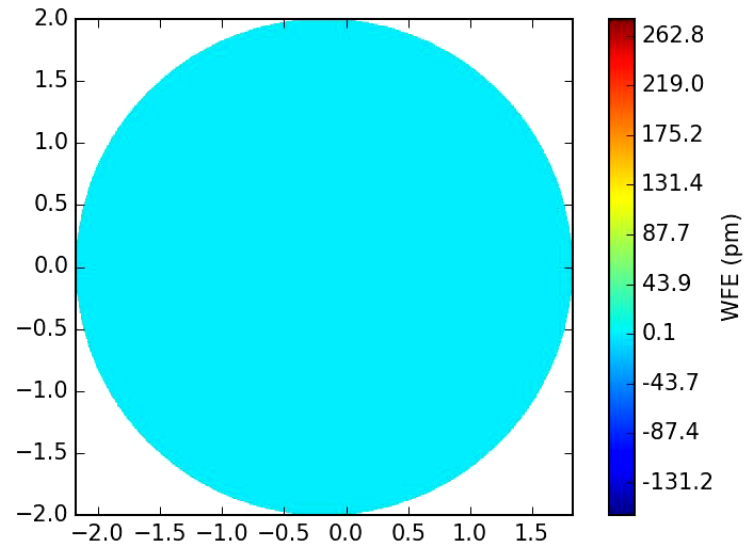

WFE/1-hour = 101 pm PV
WFE/20-min = 13 pm

Dynamic Thermal WFE

Primary mirror responds to dynamic external thermal load
Required stability (10 μm per 10 min) can be achieved by controlling the telescope thermal environment.

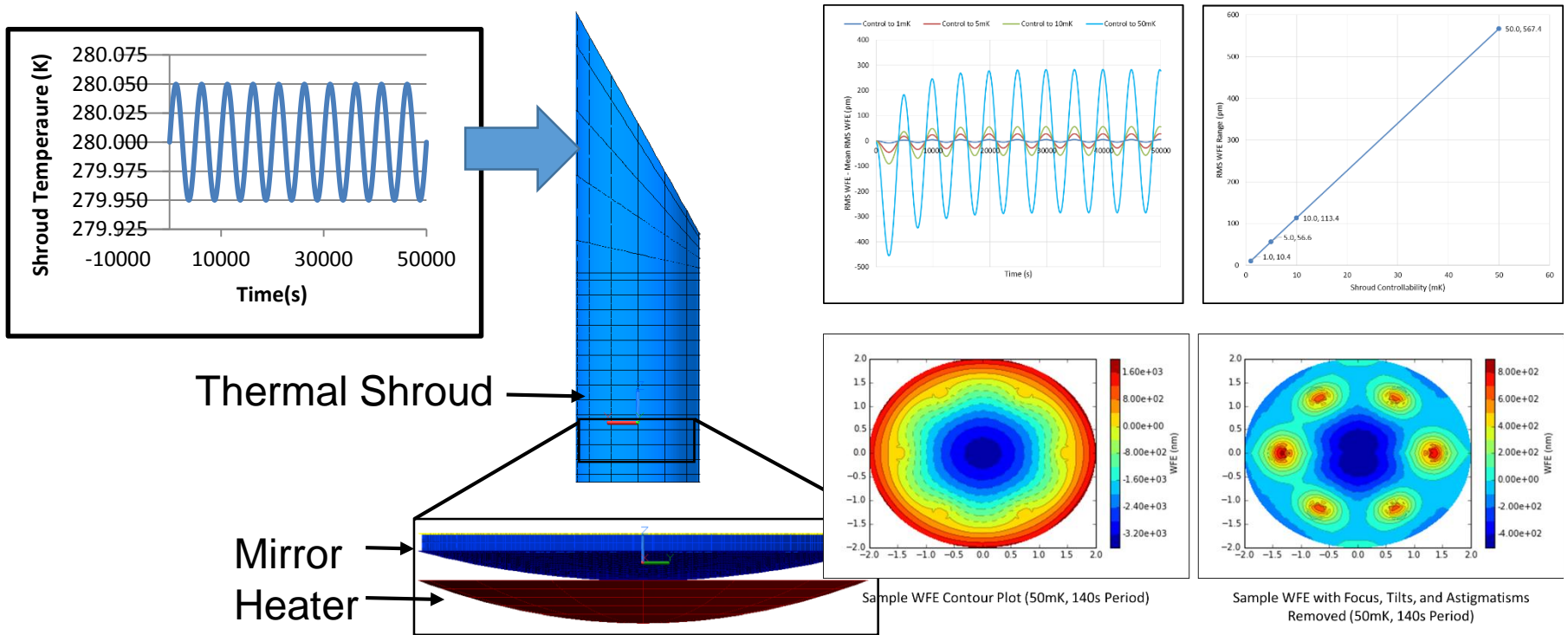

4m Aperture Transient WFE Video

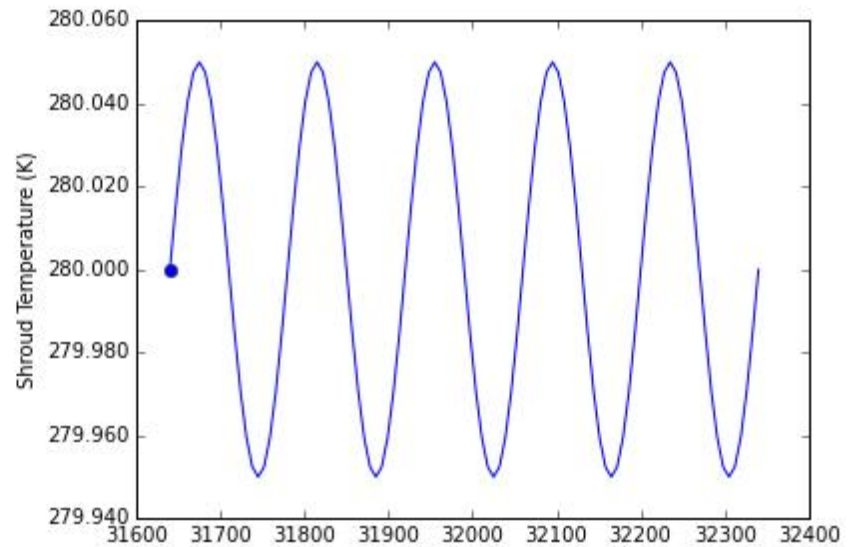
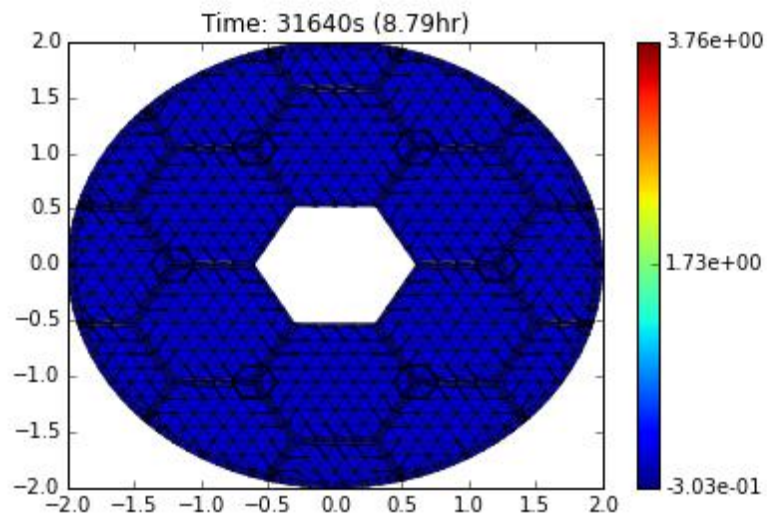

Thermal Stability

The ability to achieve any required wavefront stability depends on:

- Mirror Substrate Properties: CTE, Thermal Mass, Conductivity, etc.
- Thermal Environment Controllability
- Control Period.

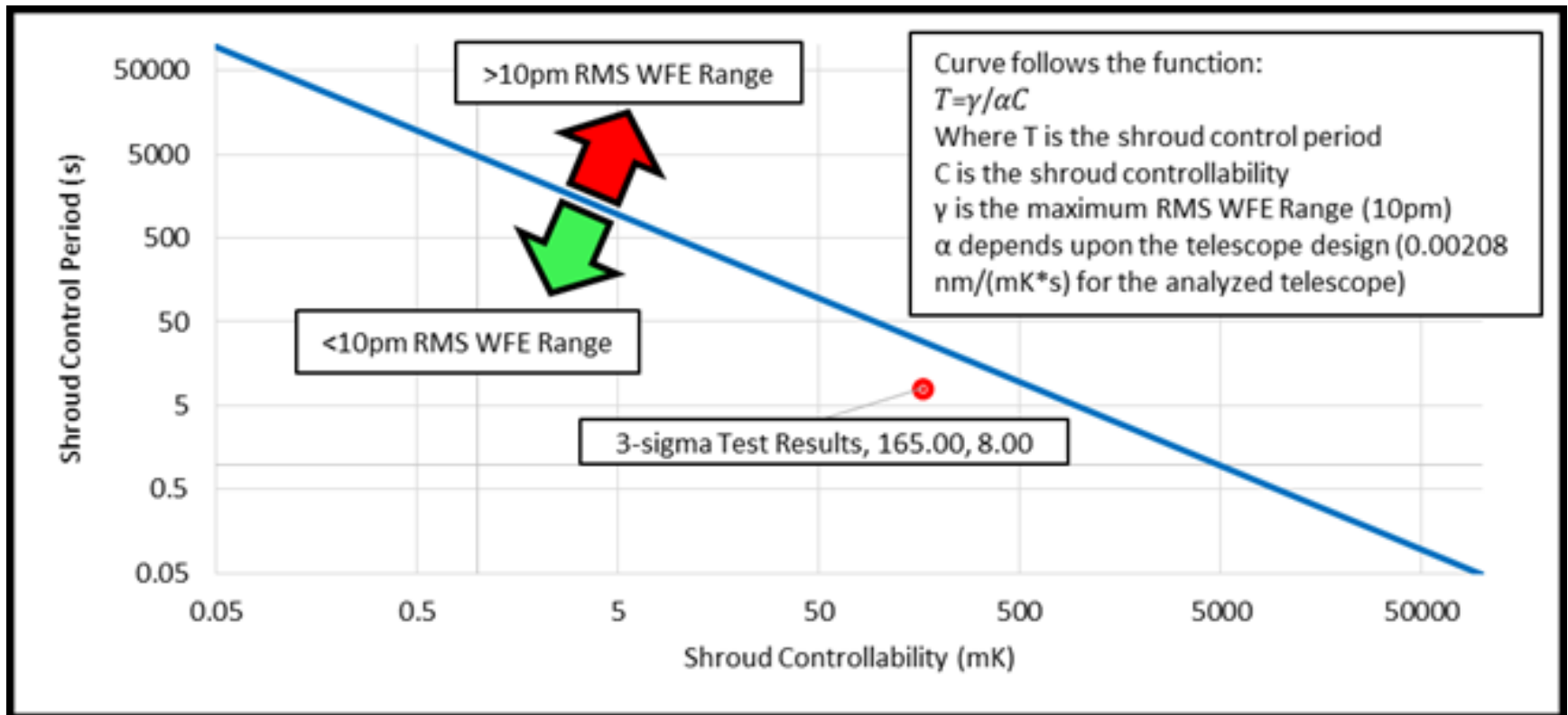

Conclusions

Conclusions

HabEx requires an OTA with unprecedented stability.

Baseline design rigid body tolerances 'Closes' for LOS and WFE
Stability using TRL9 technology

Dynamic WFE Stability analysis is on-going.

Baseline Design may require Predictive Thermal Control

BACKUP: WFE Specification

Diffraction Limit WFE

Diffraction Limit of 500 requires total system WFE ~ 38 nm rms

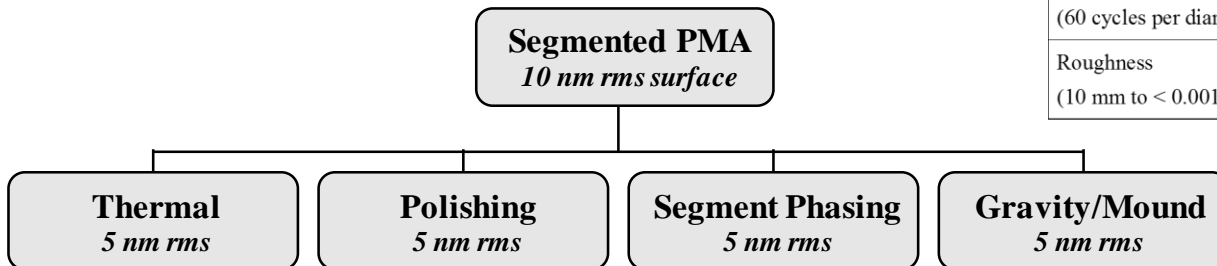
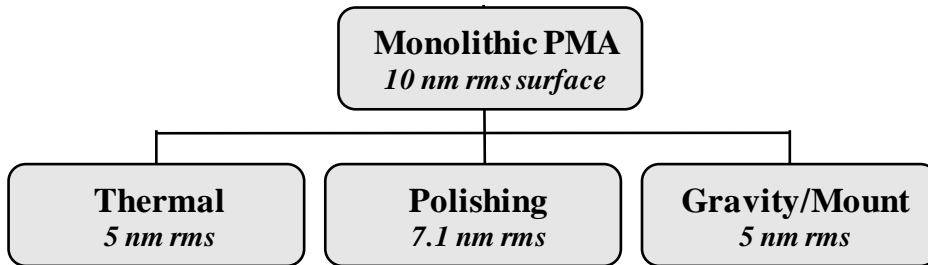
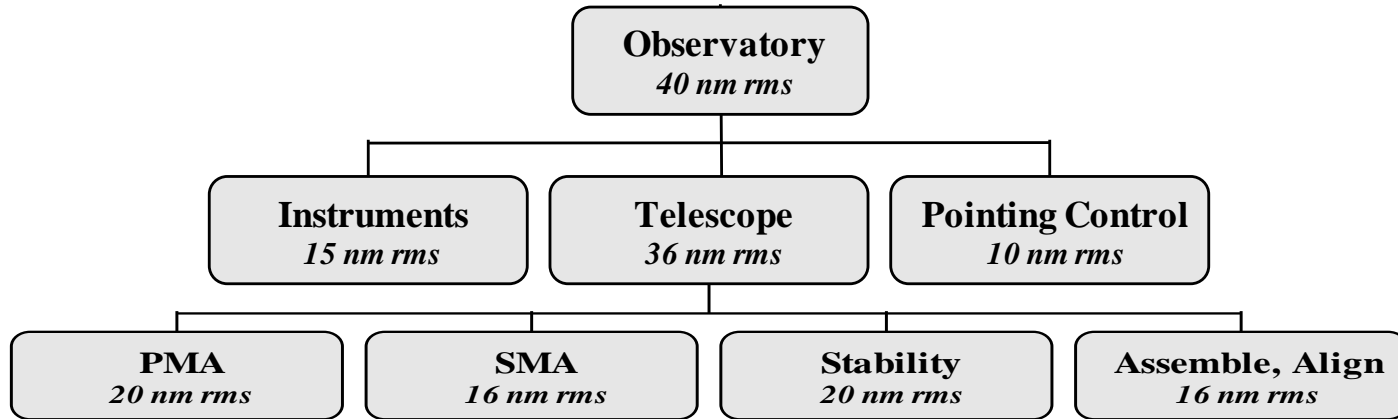

PSD Slope	- 2.0	- 2.25	- 2.5
Total Surface Error	8.0 nm rms	8.0 nm rms	8.0 nm rms
Figure/Low Spatial (1 to 4 cycles per diameter)	5.2 nm rms	5.5 nm rms	5.8 nm rms
Mid Spatial (4 to 60 cycles per diameter)	5.8 nm rms	5.6 nm rms	5.4 nm rms
High Spatial (60 cycles per diameter to 10 mm)	1.4 nm rms	1.0 nm rms	0.7 nm rms
Roughness (10 mm to < 0.001 mm)	0.6 nm rms	0.3 nm rms	0.2 nm rms

PM SFE Spatial Frequency Specification

Shaklan shows that a UVOIR mirror similar to Hubble (6.4 nm rms) or VLT (7.8 nm rms) can meet the requirements needed to provide a $< 10^{-10}$ contrast ‘dark hole’.

- If PM is conjugate with the DM, then PM low-order errors are compensated by DM.
- Recommends < 4 nm rms above 40 cycles
- Both HST & VLT surface figure error is so small enough that there is negligible Contrast reduction from frequency folding
- Because VLT is larger, stiffer and not light-weighted, it is actually smoother at frequencies of concern

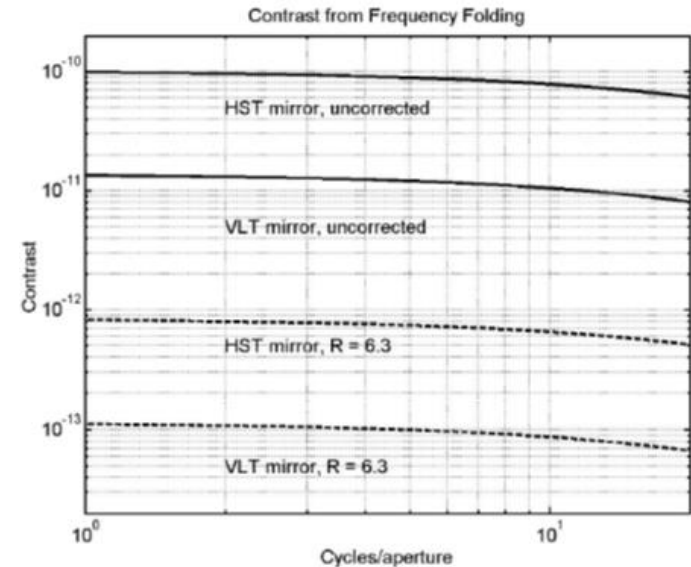

Figure 7. Contrast from frequency folding for spatial frequencies above 48 cycles per aperture, for an 8-m VLT primary and the 2.4 m HST primary. The uncompensated effect is above the required level of 10^{-12} for both mirrors. The sequential DM configuration provides about $\sim 100\times$ reduction of the contrast when it compensates the center of a 100 nm bandpass centered at 633 nm. Both mirrors are acceptable after compensation. The frequency folding effect can be perfectly compensated by the Michelson configuration and is not present in the Visible Nuller.

PM Manufacturing Specification

Define band-limited or spatial frequency specifications

Figure/Low	(1 to SF1 cycles/aperture)
Mid Spatial	(SF1 to SF2 cycles/aperture)
High Spatial	(SF2 cycles/aperture to 10 mm)
Roughness	(10 mm to < 1 micrometer)

Assume that Figure/Low Frequency Error is Constant

Key questions is how to define SF1 and SF2

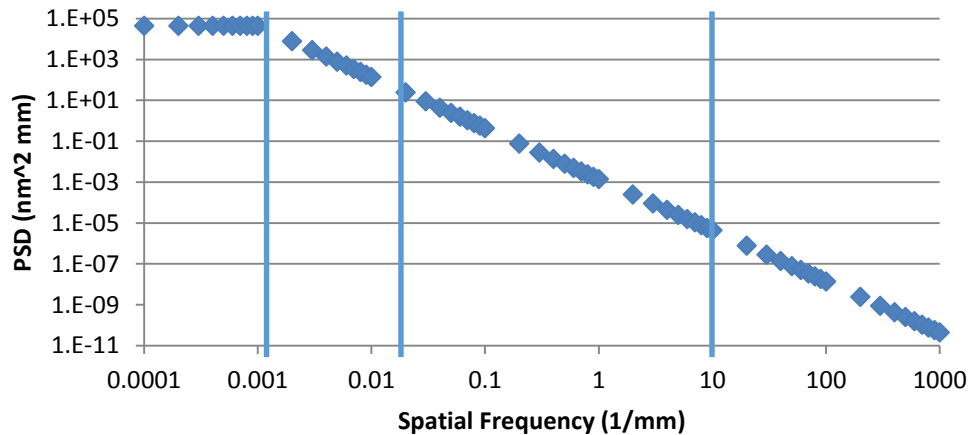

Also, what is proper PSD Slope

Low/Mid Spatial Frequency Specification

To best of my knowledge, there is no precise definition for the boundary between Figure/Low and Mid-Spatial Frequency.

Have seen values ranging from 4 cycles to 10 cycle.

Many assert that Zernike Polynomial Set defines Figure/Low

Harvey defines Figure/Low errors as removing energy from core without changing shape of core, and Mid errors as changing the shape of the core:

We choose 4 cycles

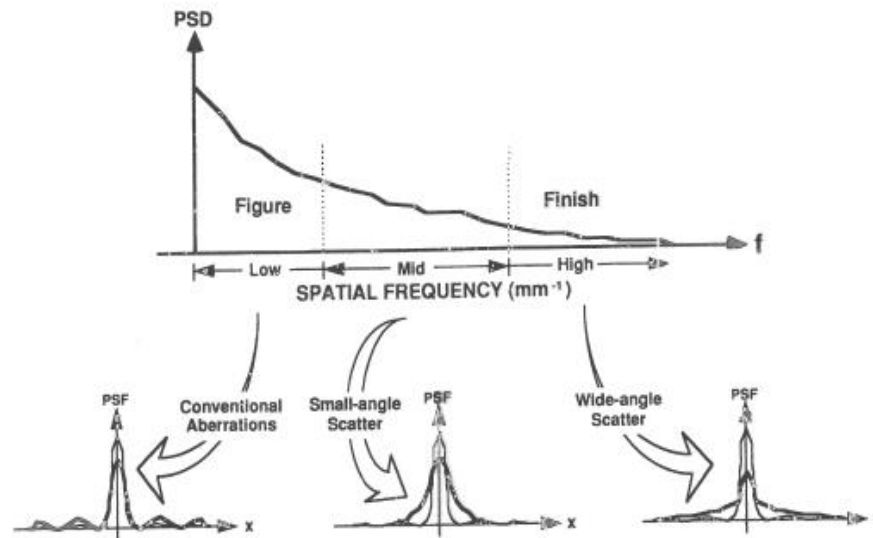

Fig. 11. Effect on image quality differs for each spatial-frequency regime.

Mid/High Spatial Frequency Specification

Exo-Planet Science requires a Deformable Mirror to correct wavefront errors and create a 'Dark Hole' for the coronagraph.

A 64 x 64 DM can theoretically correct spatial frequencies up to 32 cycles per diameter to create the 'dark hole' but in practice, the limit is approx 20 cycles per diameter.

3X aliasing can cause spatial frequency errors to put energy into the 'dark hole'; need smooth WFE up to 60 cycles/diameter.

Higher spatial frequencies scatter energy outside of 'dark hole'.

We will use 60 cycles as the Mid/High boundary.

HabEx is planning to use 96 x 96 DM (or larger) to get as large of an OWA as possible. Thus, PM must be smooth to maybe 100 cycles per diameter.

Intuition Cross-Check

JWST WFE Stability spec < 13 nm rms

Because of dampening, a warm JWST may have WFE < 2 nm rms.

HabEx Design SM Tower is ~28 Hz or ~4X higher frequency and ~16X lower amplitude than JWST.

Mass dampening gives 2X reduction.

Total SM WFE ~ 25 pm rms (coma)

JWST PM is 17 Hz, HabEx PM is 120 Hz (Zerodur) to 180 Hz (ULE) or 7X to 10X higher frequency and 50X to 100X lower amplitude.

