

Advanced Mirror Material System

The Peregrine Falcon Corporation

Mirror Technology Days

SBIR/STTR Workshop 2017

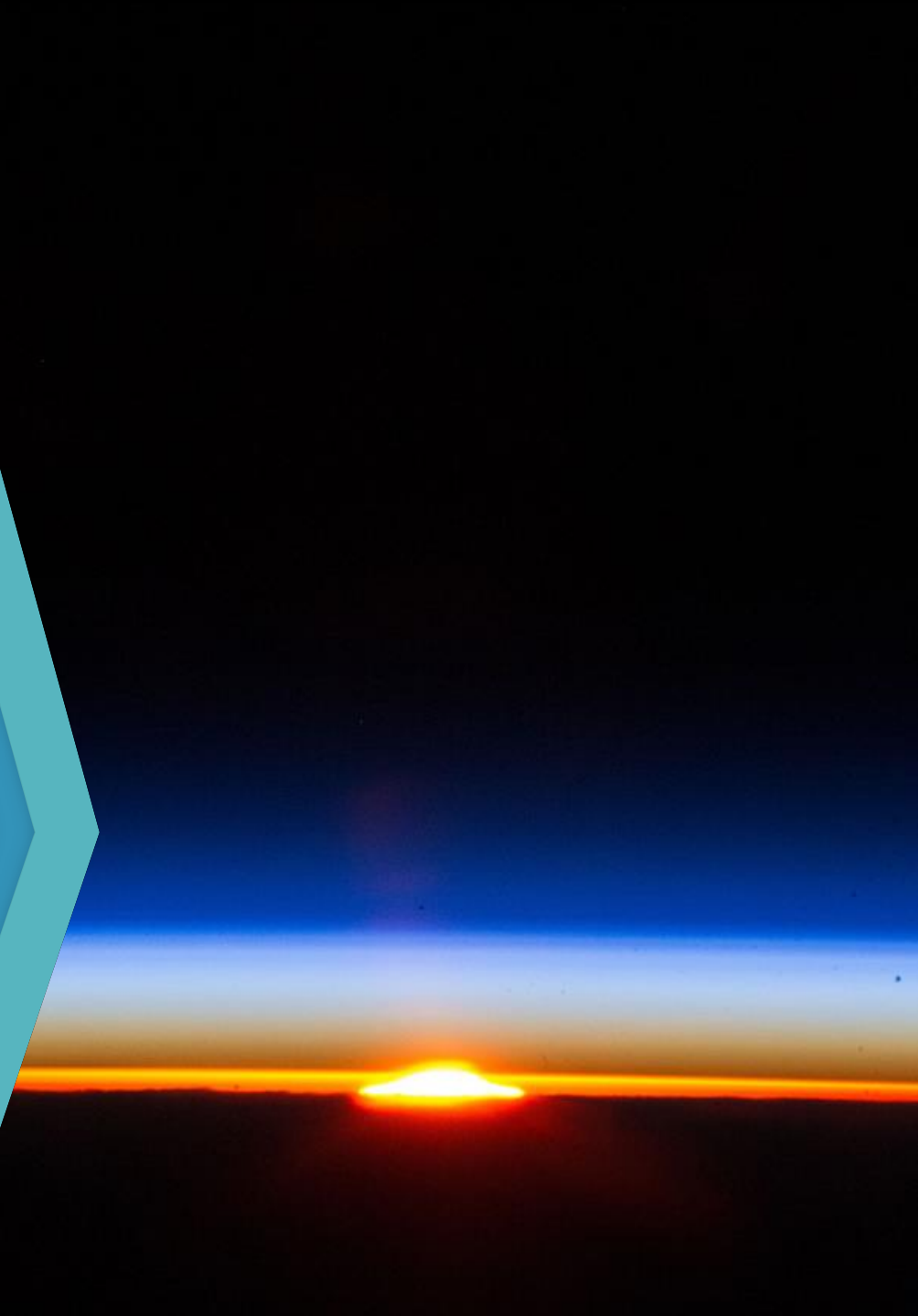

Advanced Mirror Material System

Phase II Objectives

Develop a material system that can...

- Reduce the cost of mirrors by a factor of 4 from current state of the art \$6.5 M/m², while minimizing production time in half.
- Maintain stiffness, low density, stability, and performance.
- Produce mirrors > 4 m in size.
- Match CTE of electroless nickel to Be-38Al substrate by controlling phosphorous content.
- Operate across wide temperature ranges down to low temperature.

Hardware

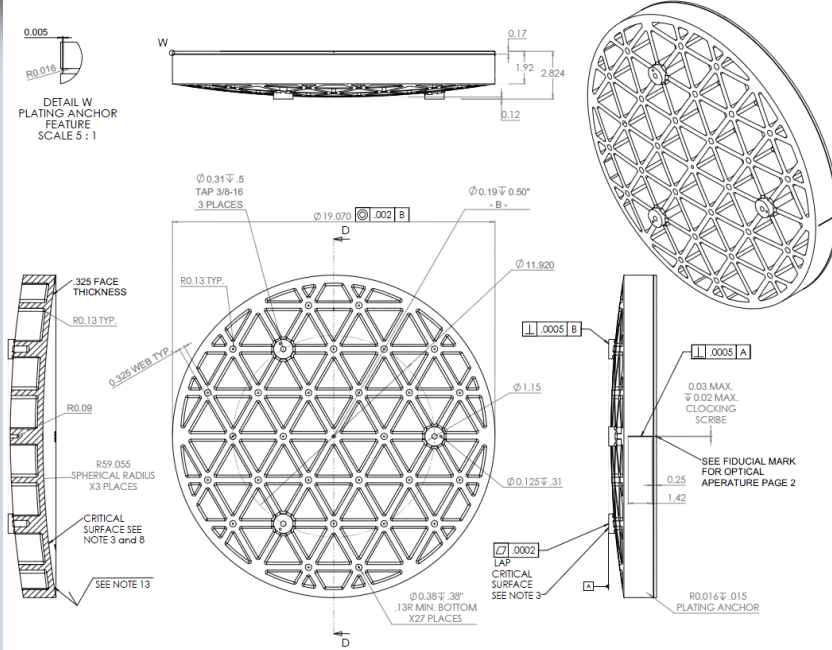
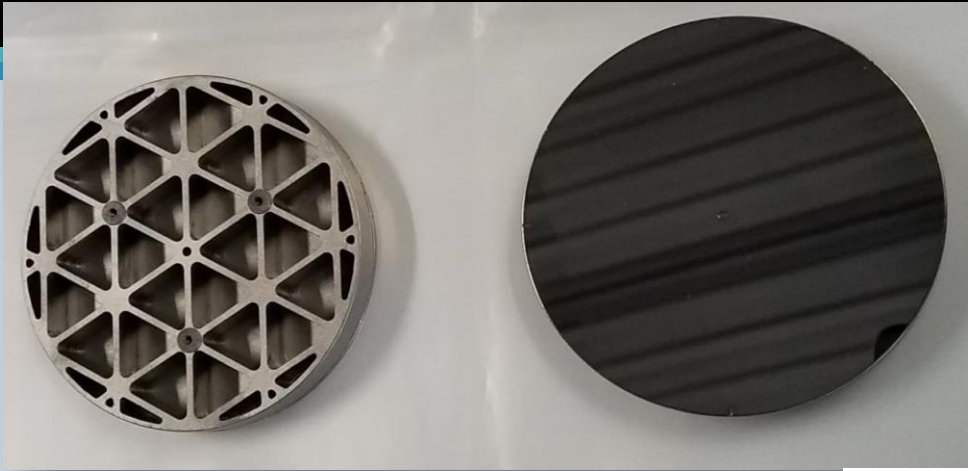

Phase II Effort

- Motivation = Make mirrors more cost effective.
 - $\frac{1}{4}$ cost of James Webb Space Telescope which was \$6.5 million/m²
- When NASA sent men to the moon, no one heard anything about budgets... now everything has to fit into a budget.

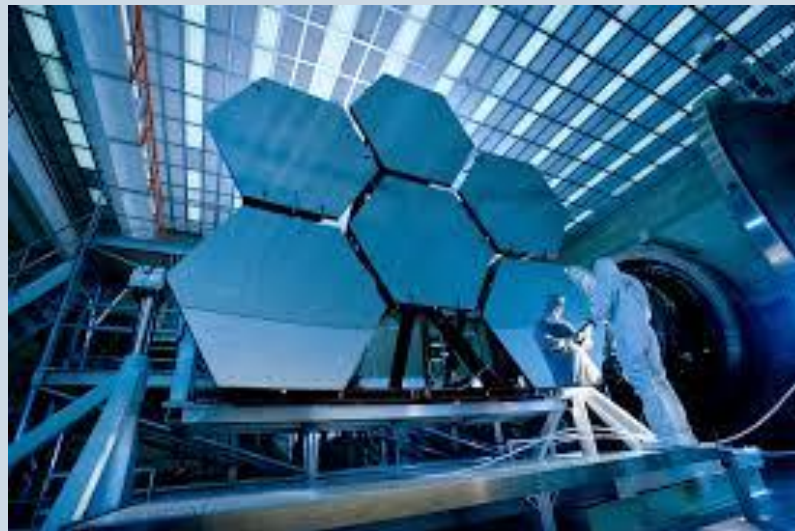
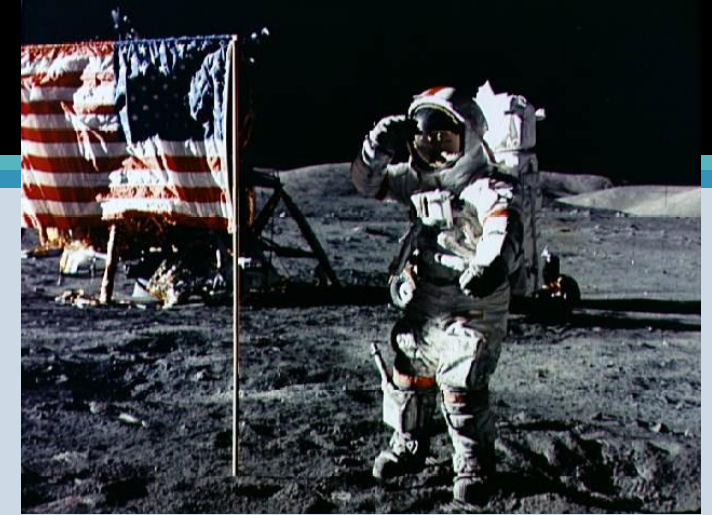

Mirrors are Getting Bigger and Bigger

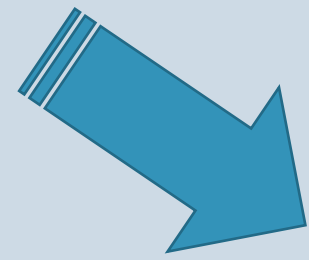

Future Larger Observatories...

Goal to Make Very Large Mirrors

The bigger the optic, the higher the cost.



Concept Sketch

Rough Surfaces
via Single Point
Diamond Turning
(Post Polish to
final
requirements)

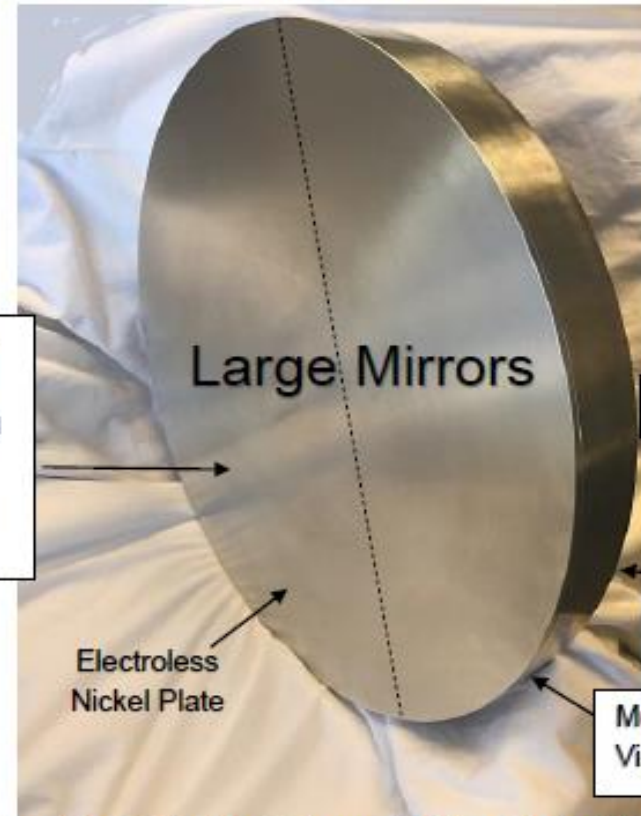

>> 1 Meter

Substrate Be-38Al

Electroless
Nickel Plate

Multi-Piece Construction-
Via LID Bonding

OBJECTIVE: Produce a Cost Effective Advanced Mirror Material System to yield large Mirrors at $\frac{1}{4}$ the cost of the State of the Art Beryllium Mirrors

Beryllium Significant Substrate Processing

Flowchart I: Beryllium RGA Integrating Structure, Machining Flow Chart

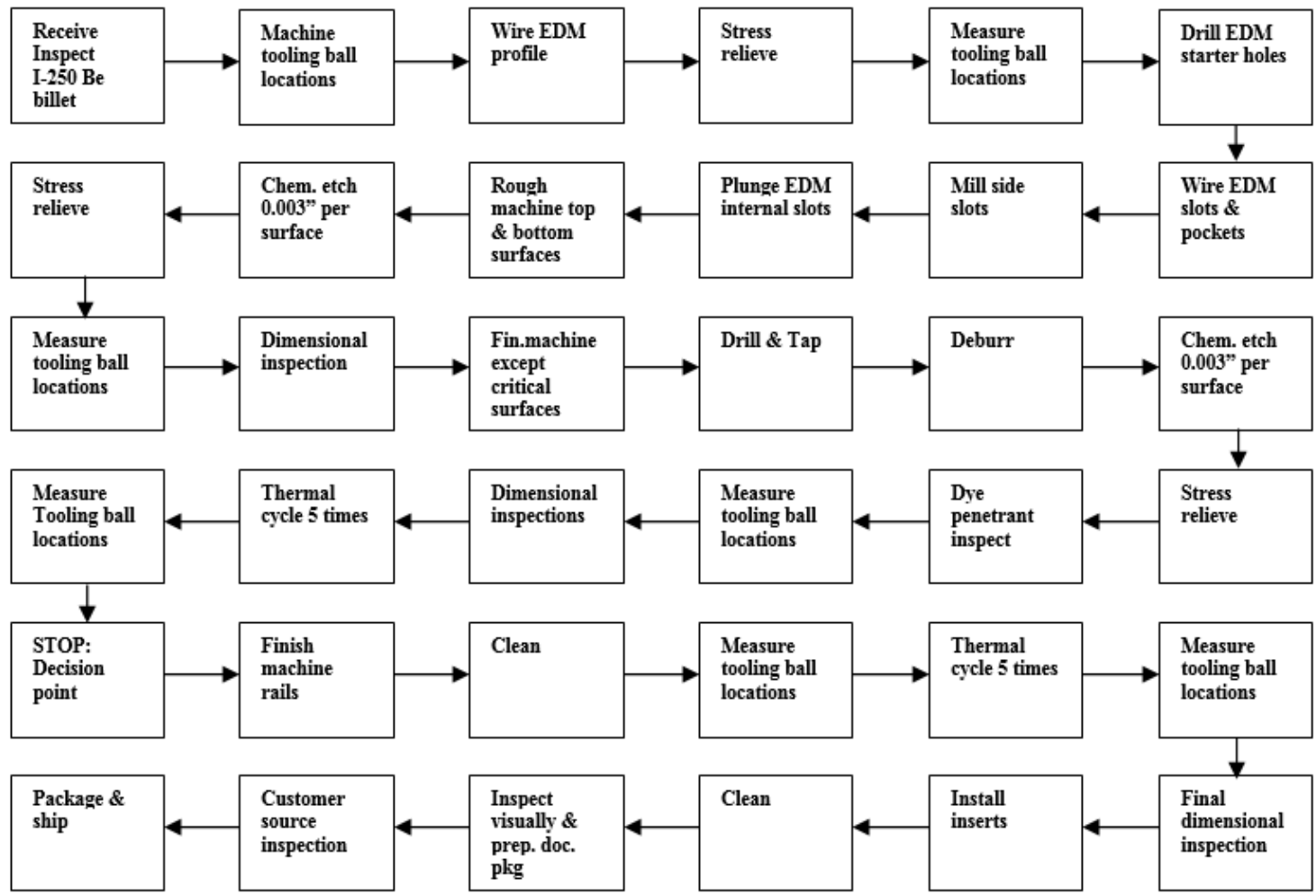

XMM

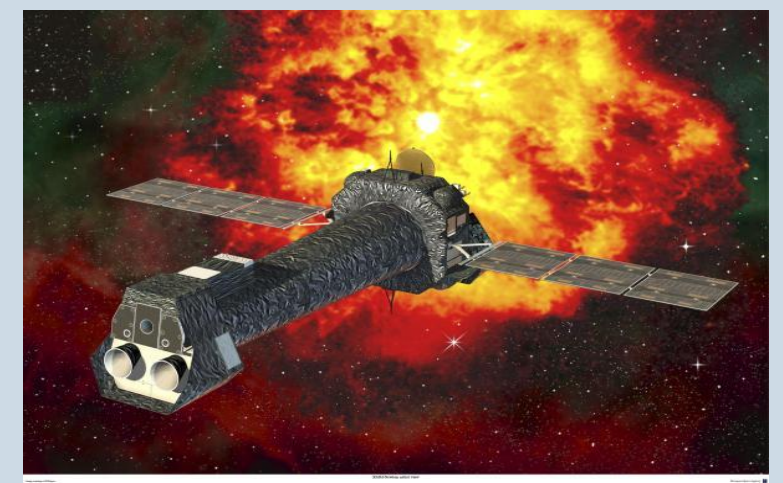

The Process

Process Be-38Al
Substrate
(AMS 7911) with
Stress Relieving

“The New”

Apply
Electroless
Nickel
(AMS 2404)

Liquid
Interface
Diffusion
Bond

Single Point
Diamond
Turn

*Results in a large
reduction in the
number of processing
steps compared to Be.*

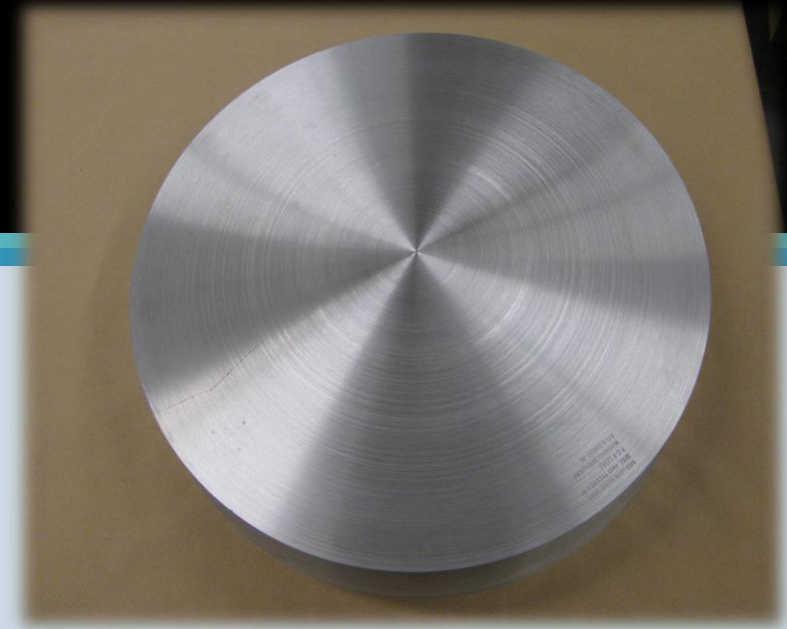

Mirror Substrate: Be-38Al (LockAlloy)

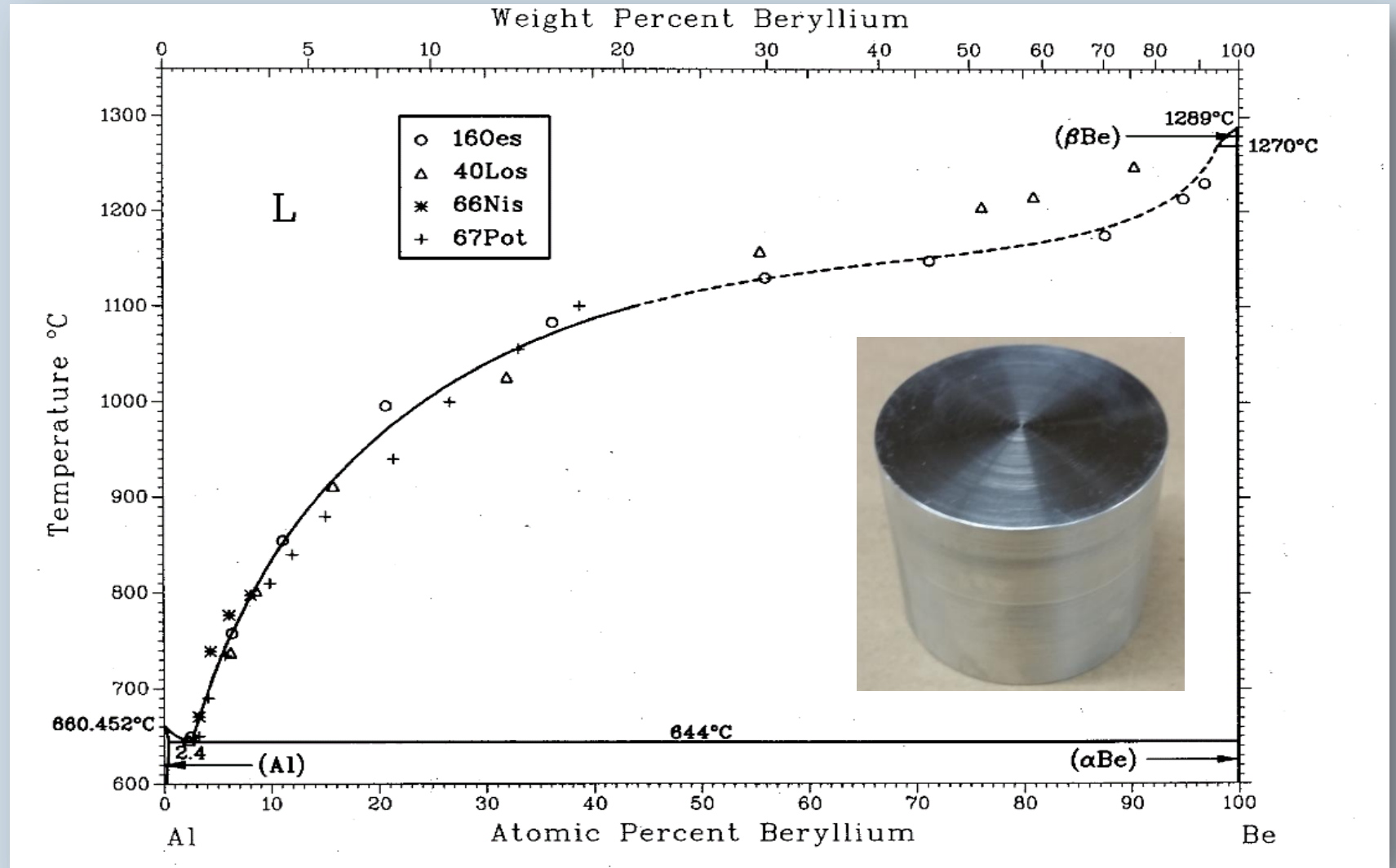
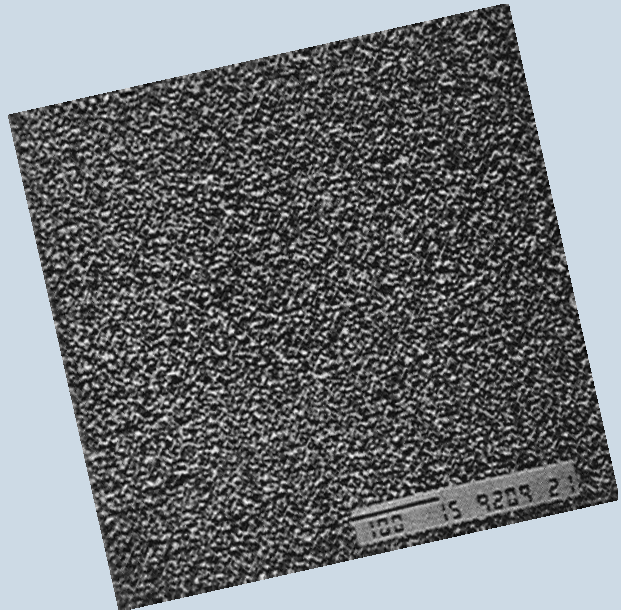

Be-38Al

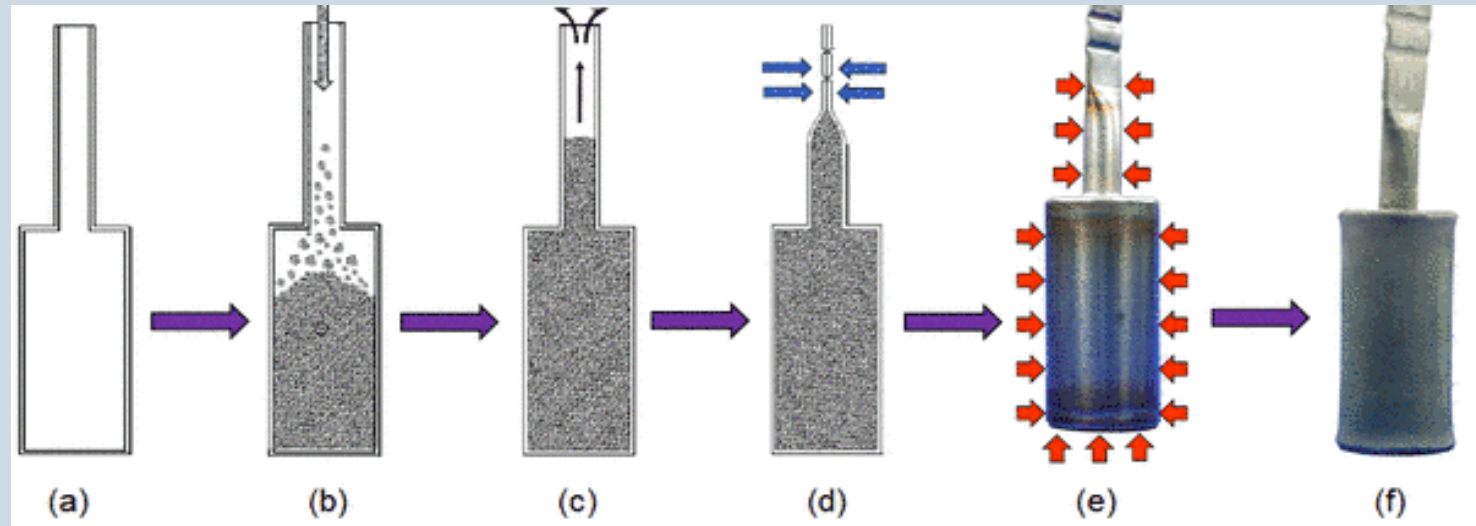
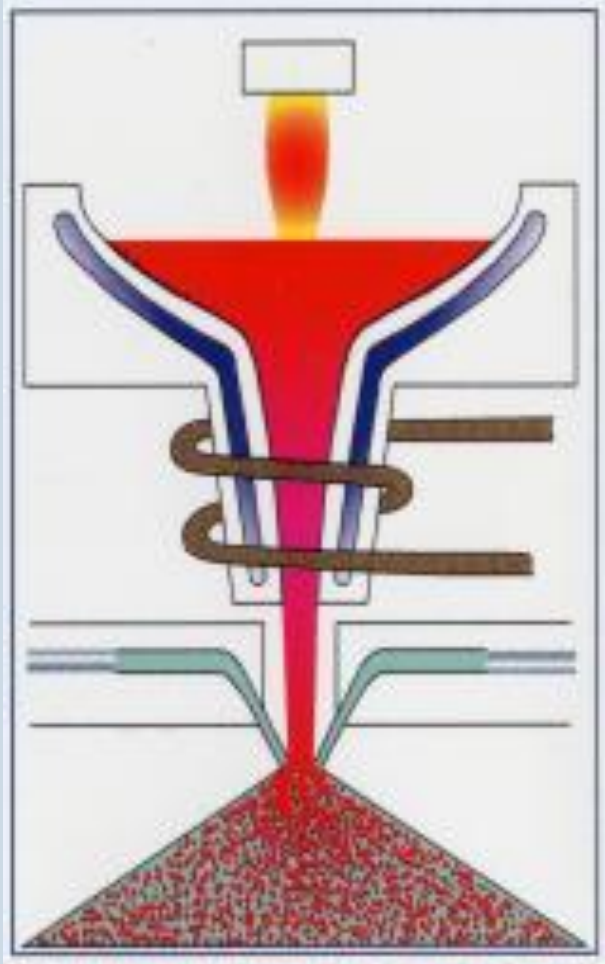
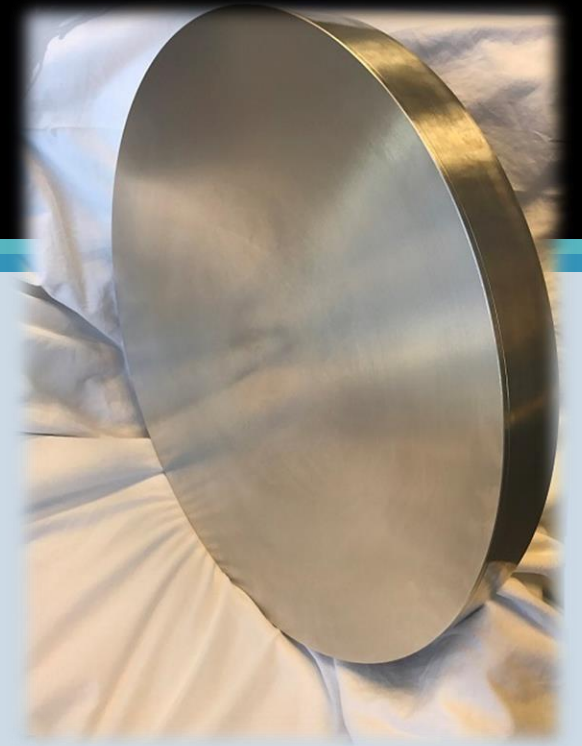
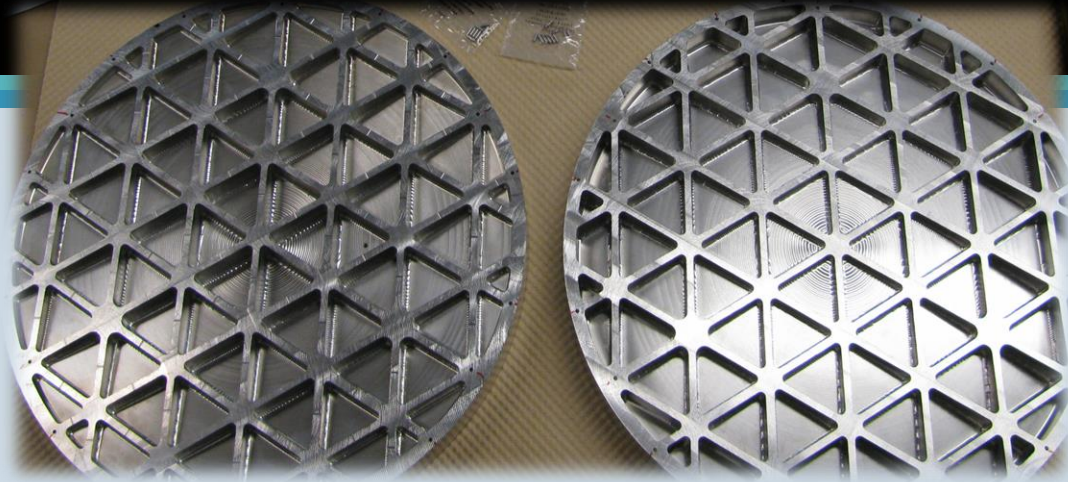

Material Comparison Chart of Metals

(Ambient Temperature Properties)

Property	Be AMS 7908	Be-38Al AMS 7911	Aluminum 6061 T6	Titanium Ti-6Al4V	Magnesium AZ91D-F
Density (g/cc)	1.85	2.10	2.70	4.43	1.81
Thermal Conductivity (W/mK)	216	210	167	7.8	72.7
CTE (ppm/°C)	11.4	13.9	22.9	9.0	26
Modulus of Elasticity (GPA)	303	192	69	110	45
Ductility (%)	2	2	8	10	3
Yield Strength (MPa)	241	192	255	1034	150
PEL (MPa)	>30	17.3	<6.5	N/A	NA
Specific Heat (J/kg°K)	1925	1506	896	597	NA
Electrical Conductivity (% IACS)	41	45	43	N/A	<40
Melting Point (°C)	1285	1082	652	1660	650
Specific Stiffness	164	91	26	25	25

Mirror Surface: Electroless Nickel

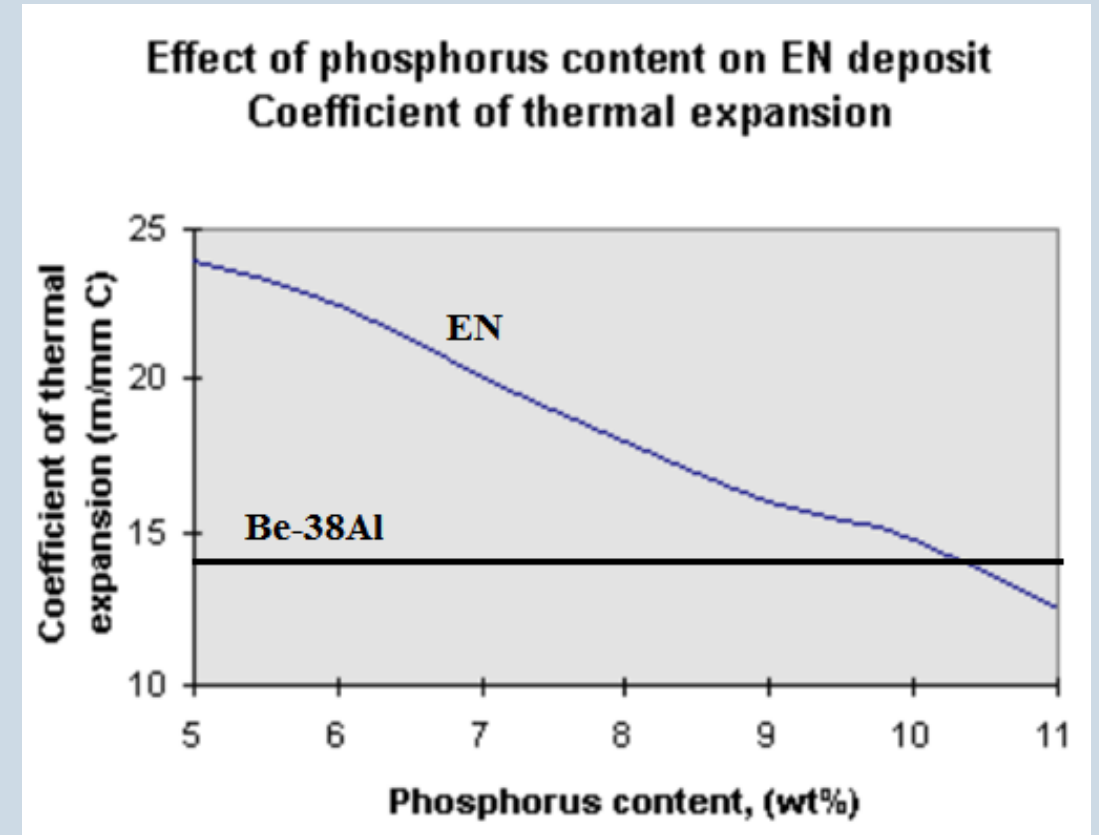
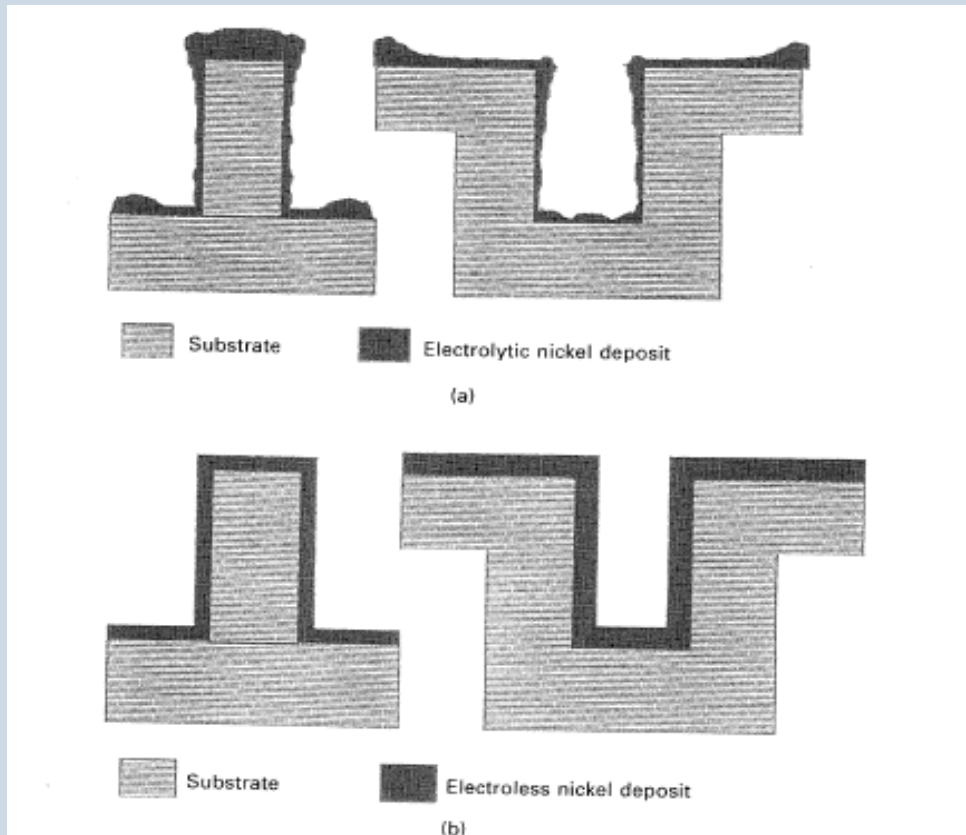

In Phase I, we demonstrated a phosphorous match.

Influences on the As-Plated Nickel Deposition Residual Stress

- Bath Chemistry (Including P%)
- pH
- Temperature
- Agitation
- ***MTO (Metal Turn Over; small amount of solution drained of (~1%); solutions added)***
 - The bath age
 - Fresh Bath; deposition layer tends to have residual stresses that are in compression (~5,000 psi).
 - Baths with 3 MTO; depositions tend to be stress free (use in line controller to maintain MTO 3 bath).
 - Baths with over 3 MTO; depositions tend to have residual stresses that are in tension (~3,500 psi).

Electroless Nickel

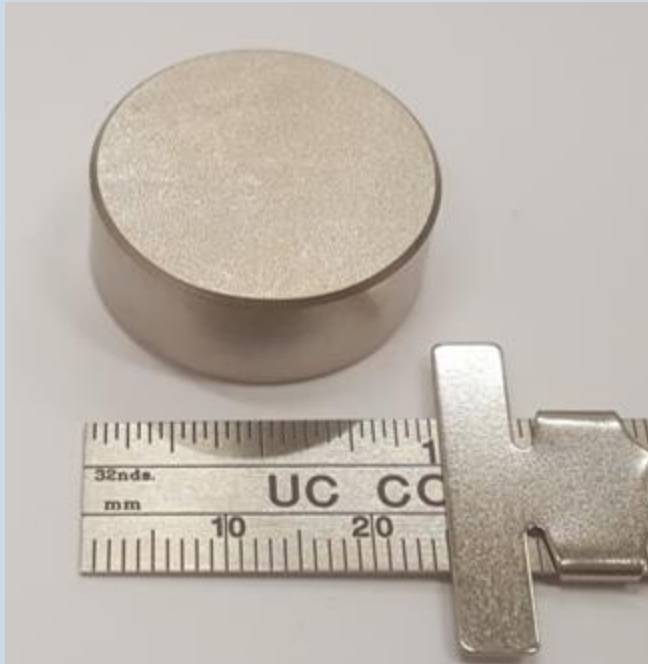

Cross Section of Electroless Nickel

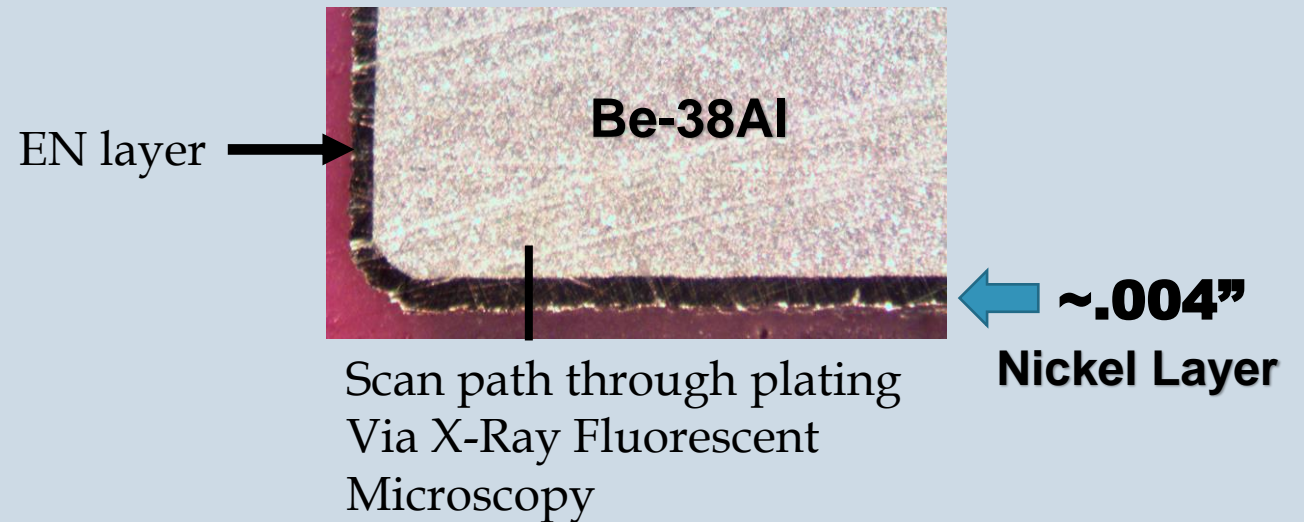

The sample to the left is cut in half and the cross section polished. The view to the right shows the cross-section and the X-ray beam scan line

Electroless Nickel

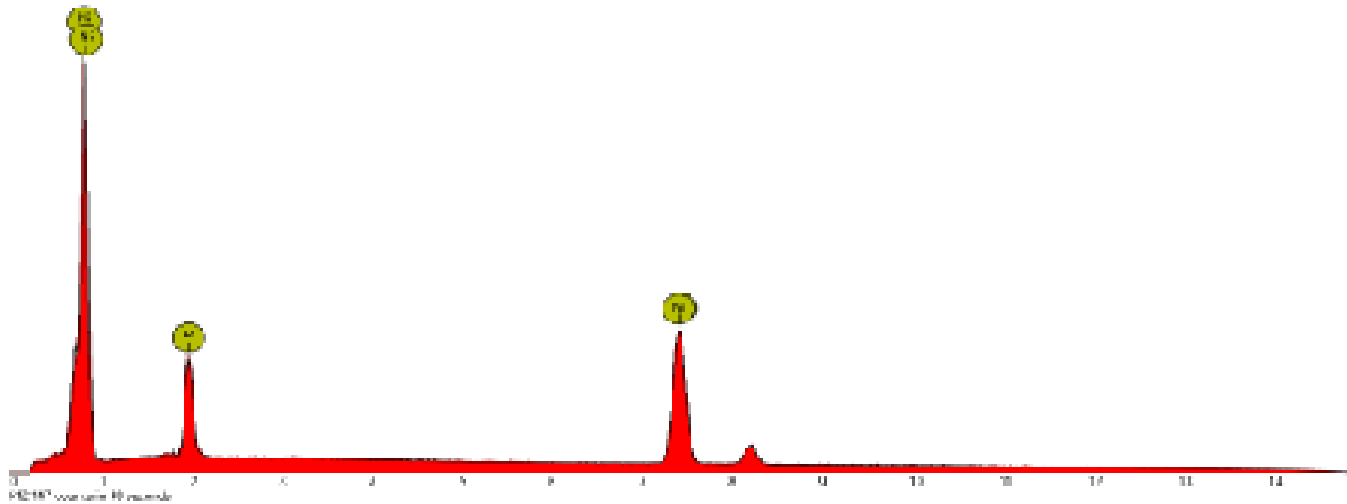

X-Ray Analysis of Spot 2 on Sample A-1

Qualitative Elemental Analysis (Preliminary)				
Element Number	Element Symbol	Element Name	Weight Concentration	Error
28	Ni	Nickel	88.6	0.0
15	P	Phosphorous	11.4	0.0

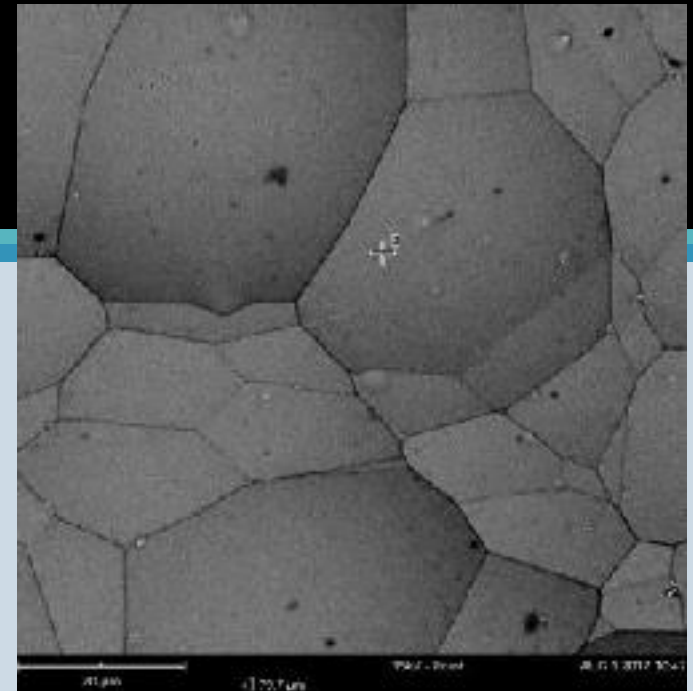

X-Ray Analysis of the Cross Section of EN Plating

X-Ray Fluorescent Microscopy

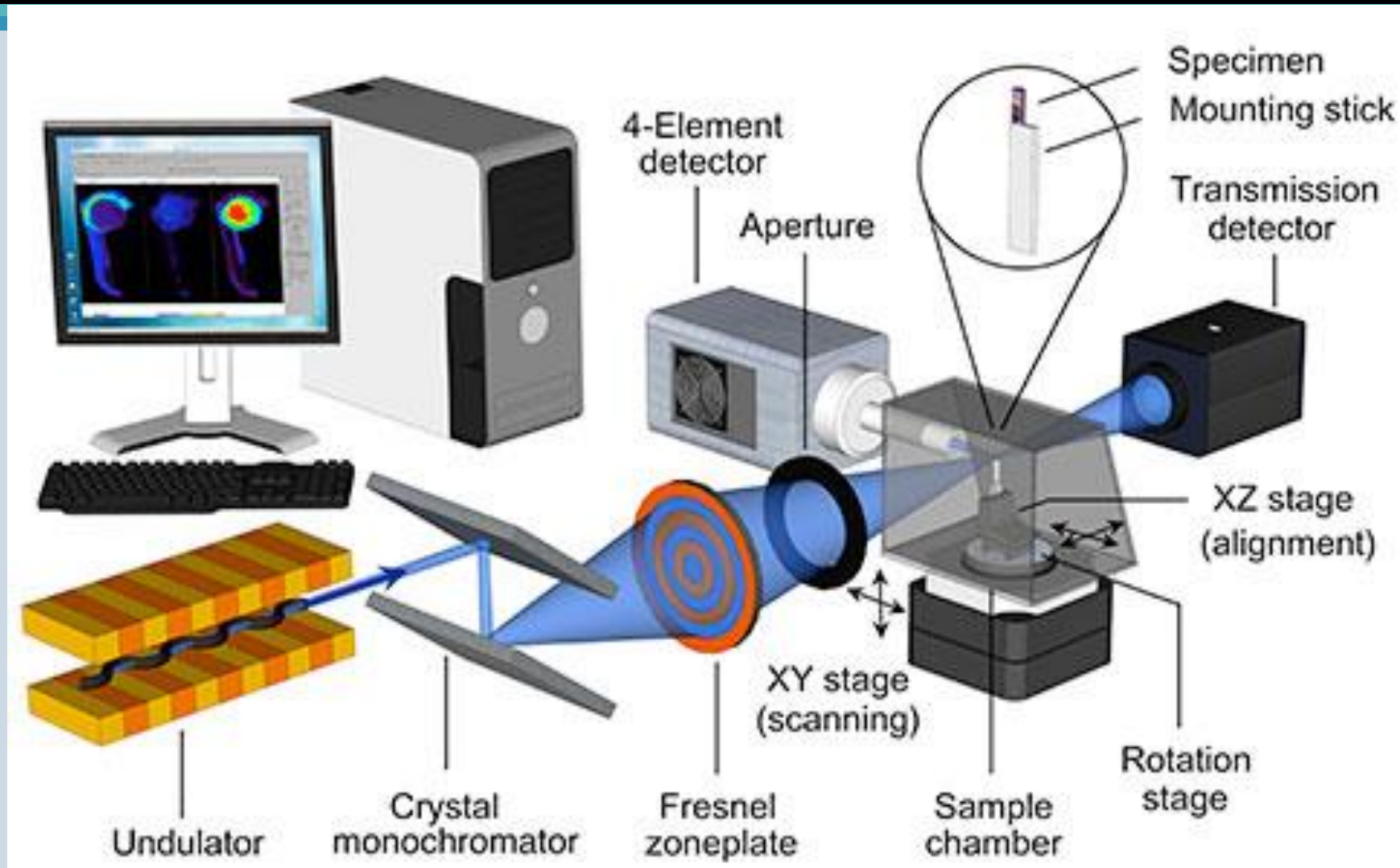

Through the Thickness Elemental Composition of a Peregrine Sample (10 keV Beam, 300 nm Size)

X-ray Microfluorescence

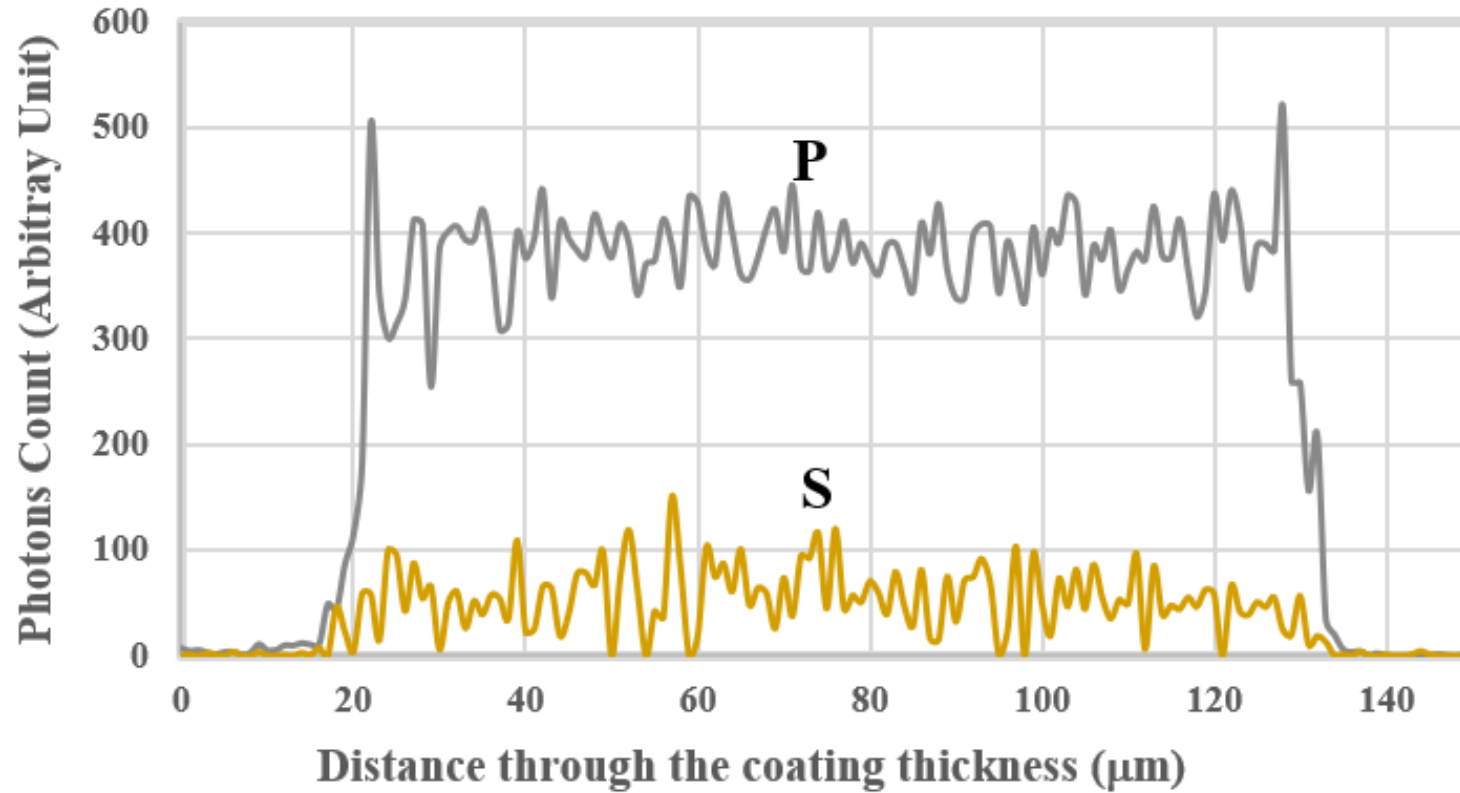

Demonstrates the
“Power of Technique”

Variations of P & S elements concentration through the thickness of a sample 100 μm coating

Through the Thickness Elemental Composition of a Peregrine Sample

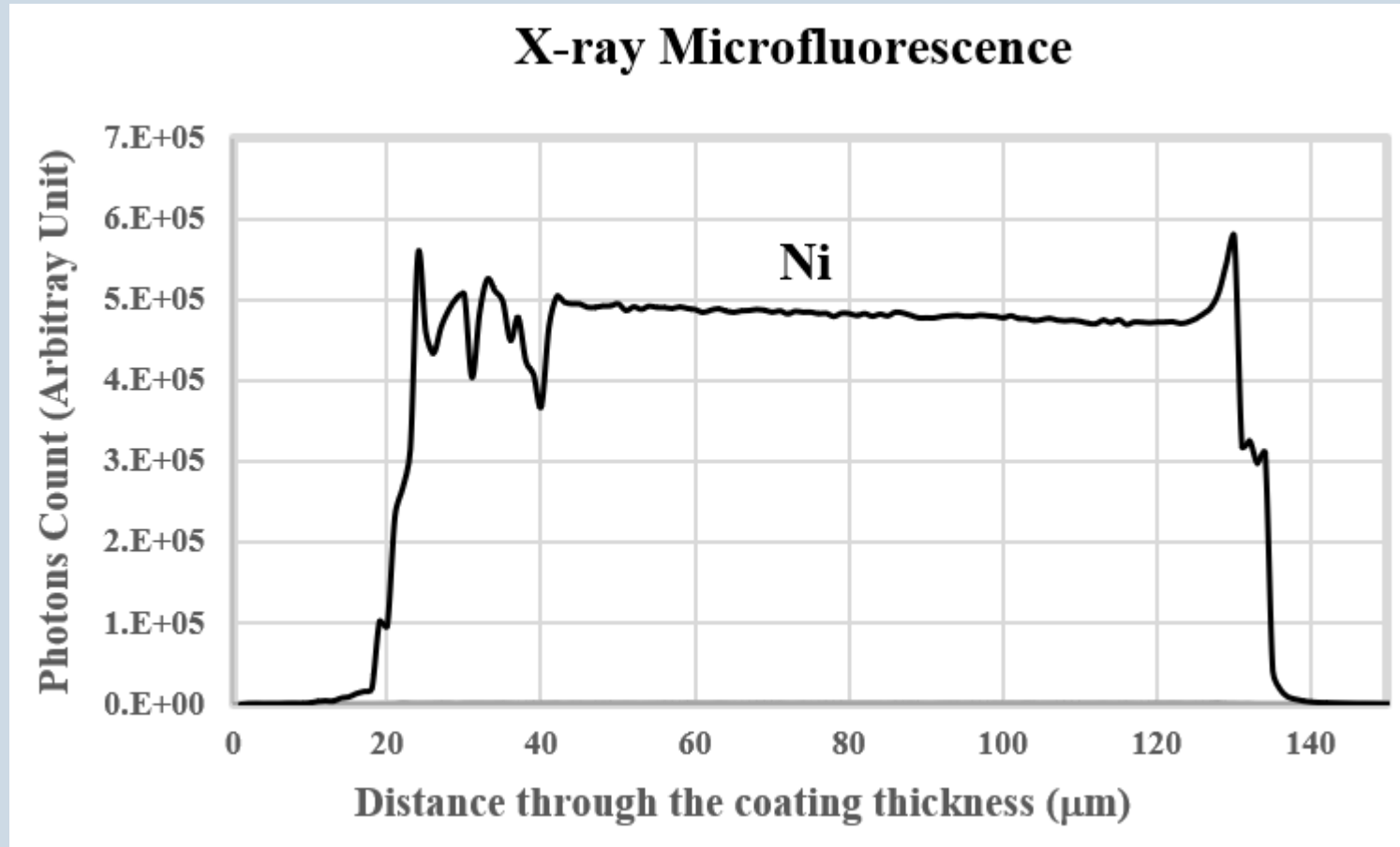

Variations of Ni concentration through the thickness of a sample 100 μm coating

Allowable Stress

Achieving a “stress free” substrate then:

Max allowable range of stress in the system (compressive or tensile) σ_{\max}

Thermal expansion and Youngs modulus of substrate $\alpha_s(T), E_s(T)$

Thermal expansion and Youngs modulus of plating $\alpha_p(T), E_p(T),$

Temperature of the bath T_{bath}

Lets define residual stress σ_r

$$\sigma_r = \int_{T_{\text{bath}}}^T [E_s \alpha_s(T') - E_p \alpha_p(T')] dT'$$

where the integration limit T is any temperature in the operating range at which σ_r has a maximum (tensile) or minimum (compression)

Manage the Bath to Minimize Residual Stress

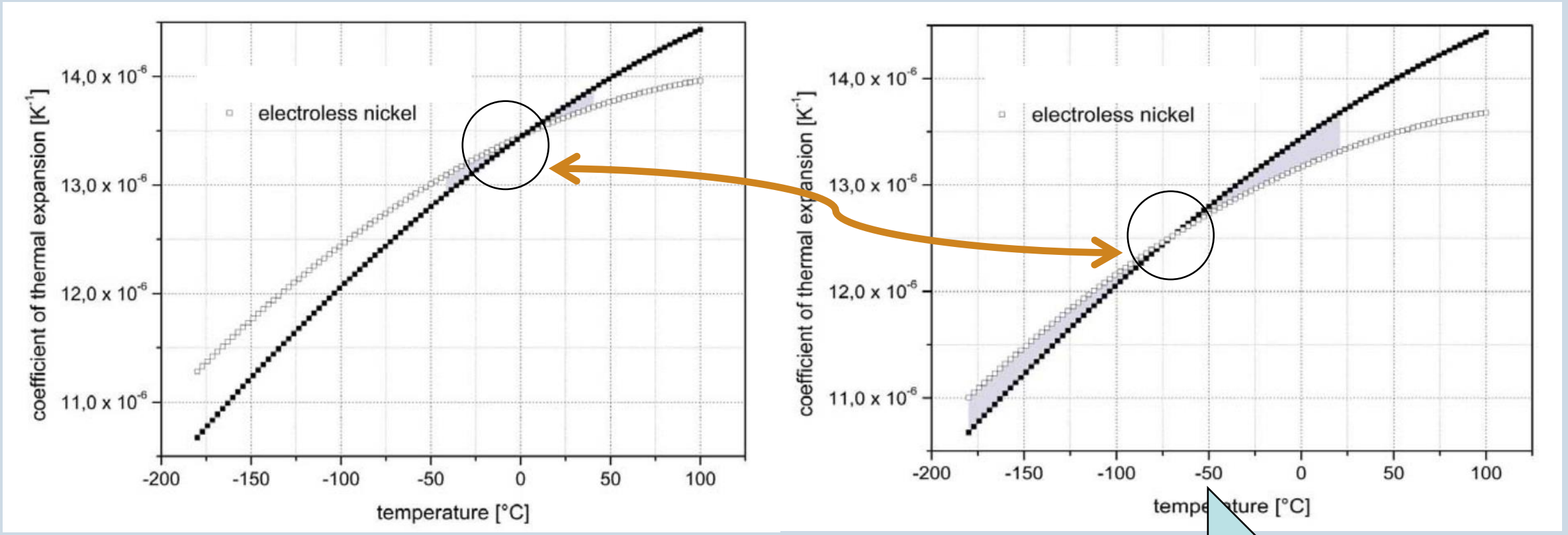

Minimizing residual stress is a function of controlling chemistry, pH, temperature, & "age" of bath .

Joining: Liquid Interface Diffusion Bonding

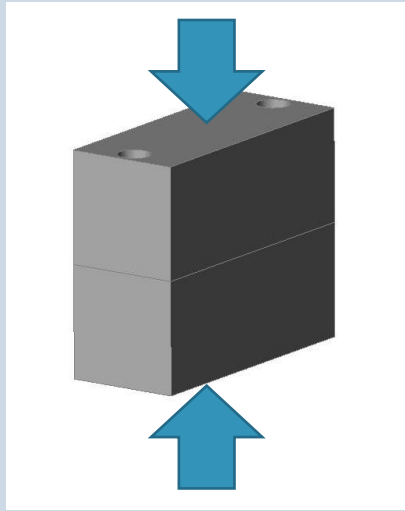
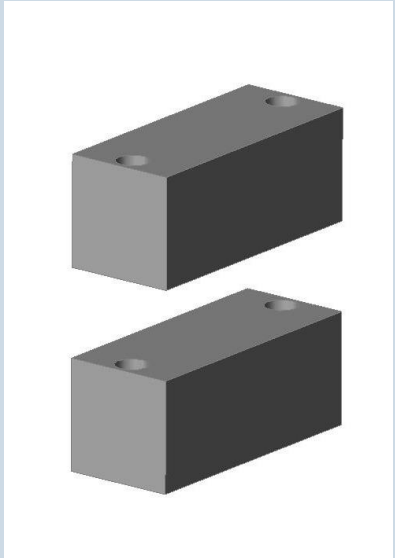

**Parts Joined Together under
Temperature and Pressure**

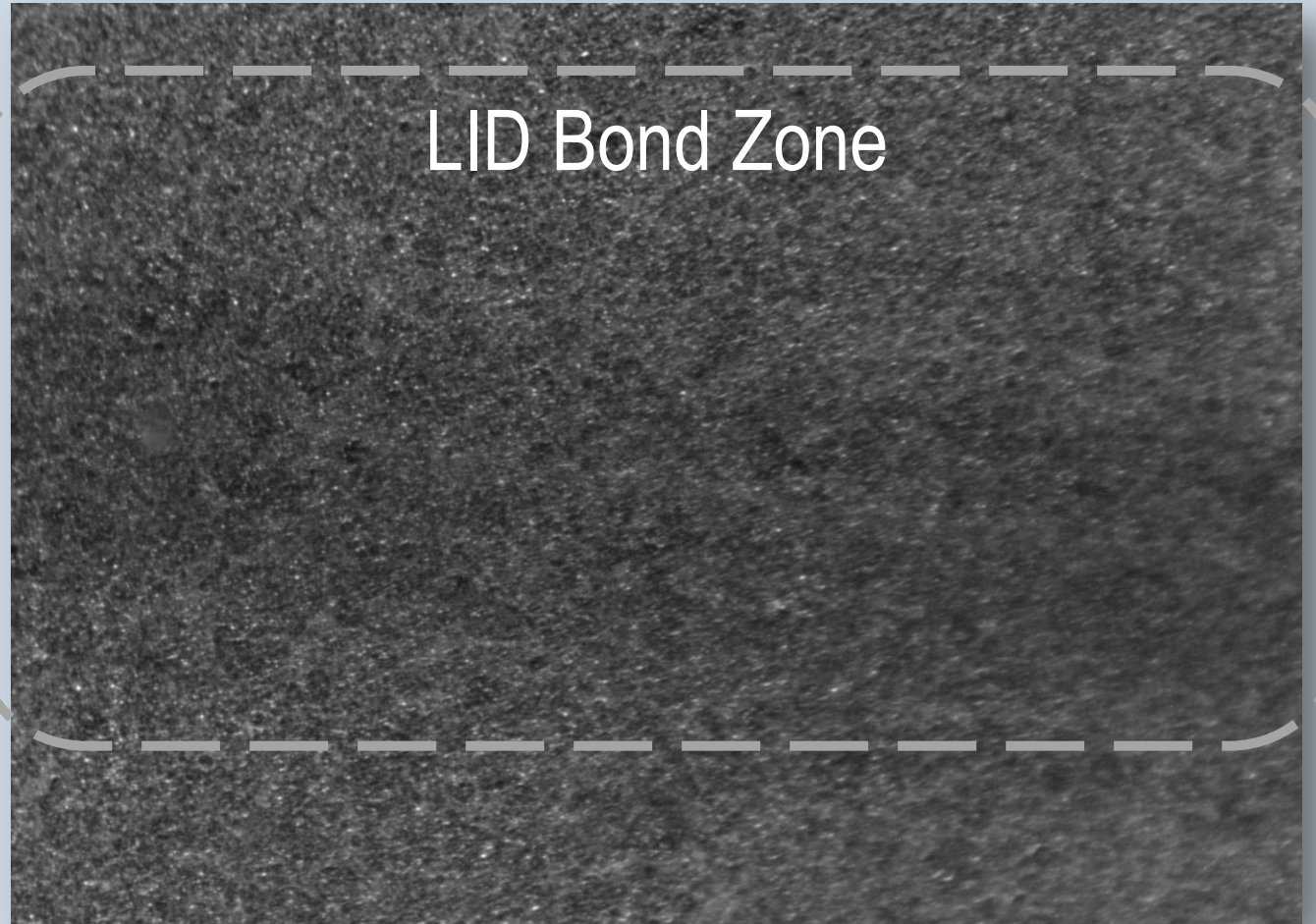

Liquid Interface Diffusion Bonding

Enables large mirror production.

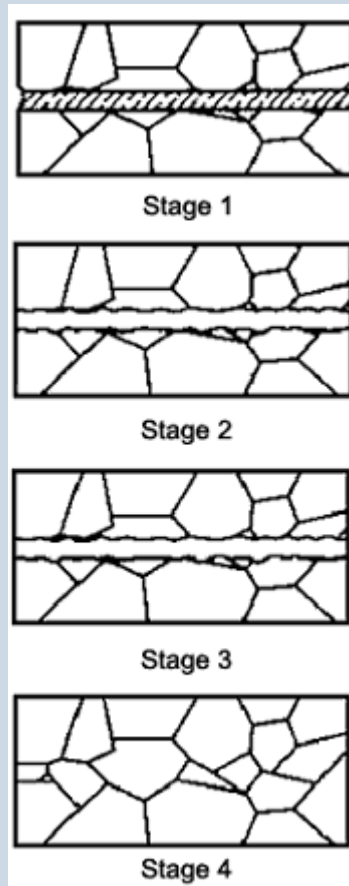

The major stages in LID Bonding...

1. Preplacement and fixturing of parts
2. A liquid front smooths the interfaces
3. The intermediate layer diffuses into the base metal
4. Diffusion occurs to create a homogeneous joint

Mirror Surface: Single Point Diamond Turning



Integrated Test: 90 mm Mirrors

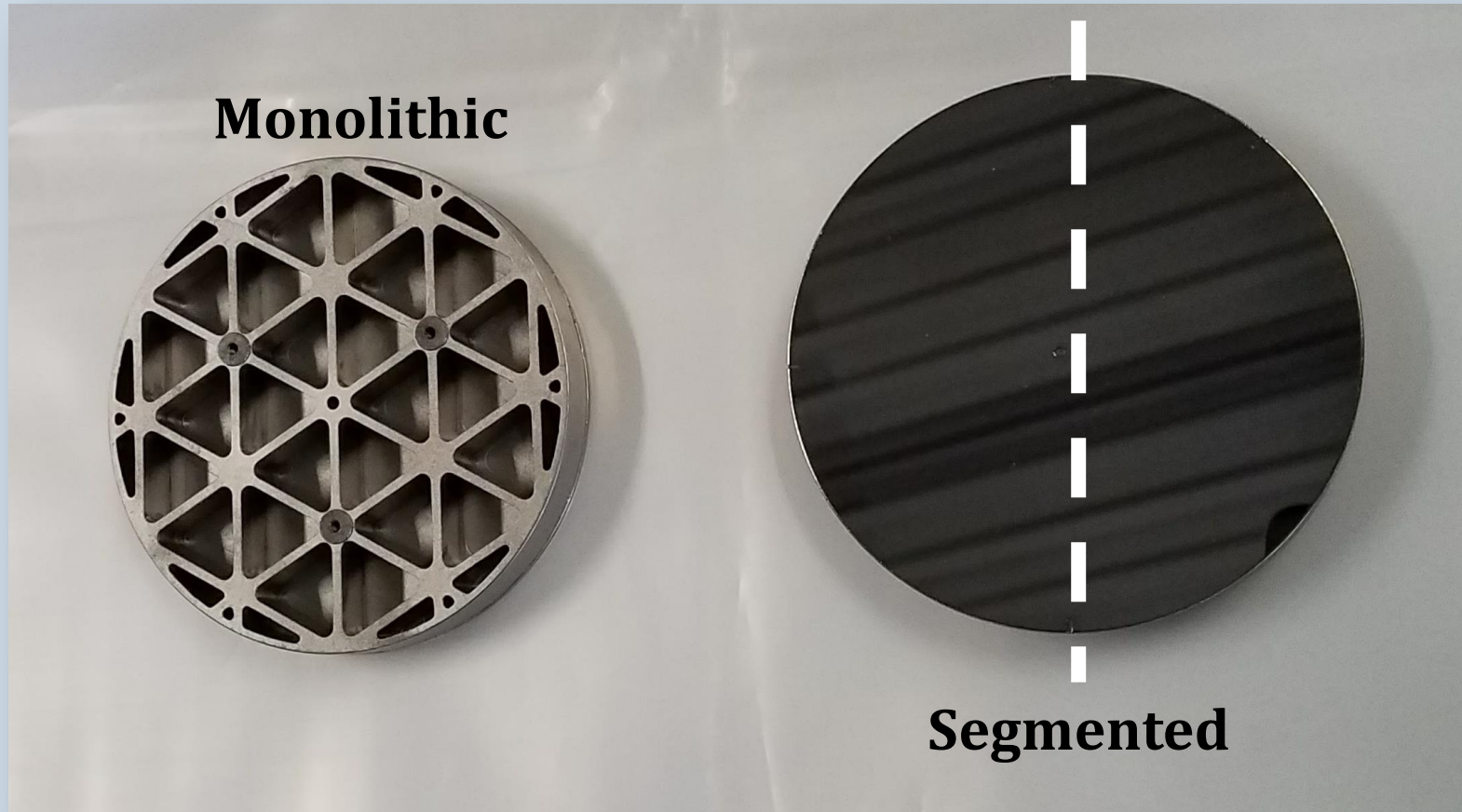

Both the monolithic and segmented mirrors were processed through electroless nickel side by side. Only thing that is different in the second one is that it was liquid interface diffusion bonded together.

Monolithic Mirrors

Manufacturing Flow Chart

(Major Steps for the Monolithic Mirrors)

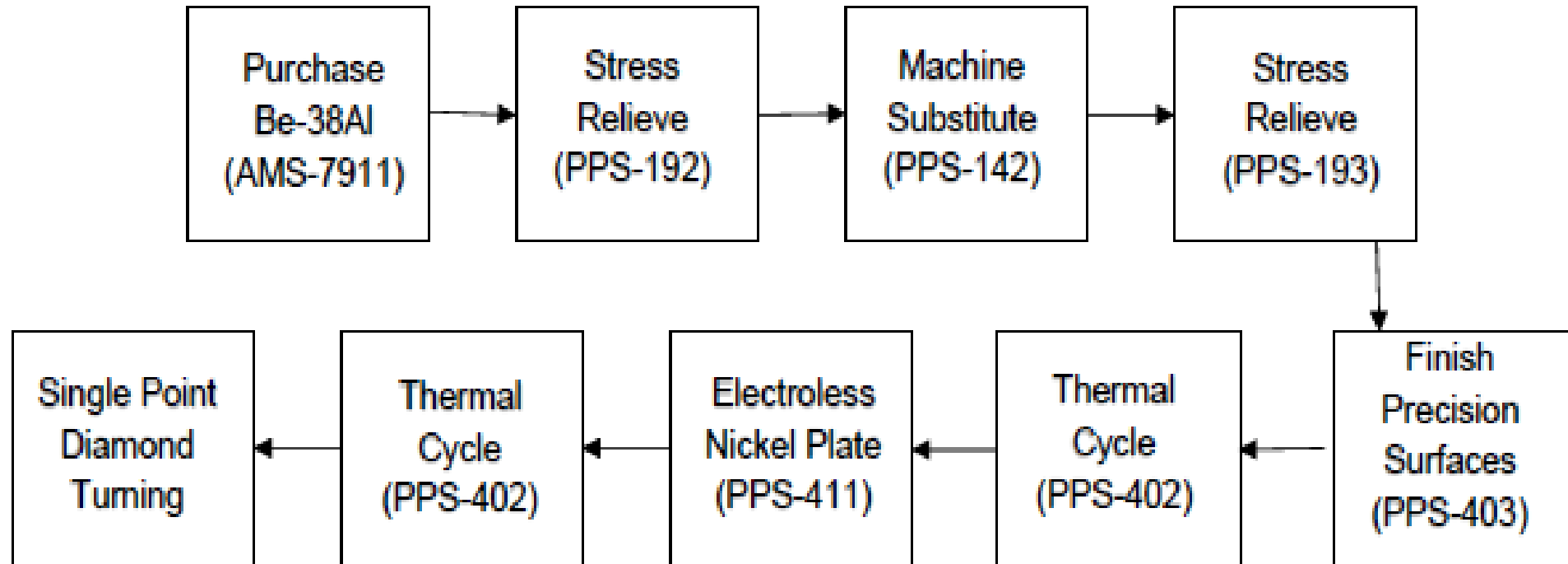

Monolithic Mirrors – Baseline

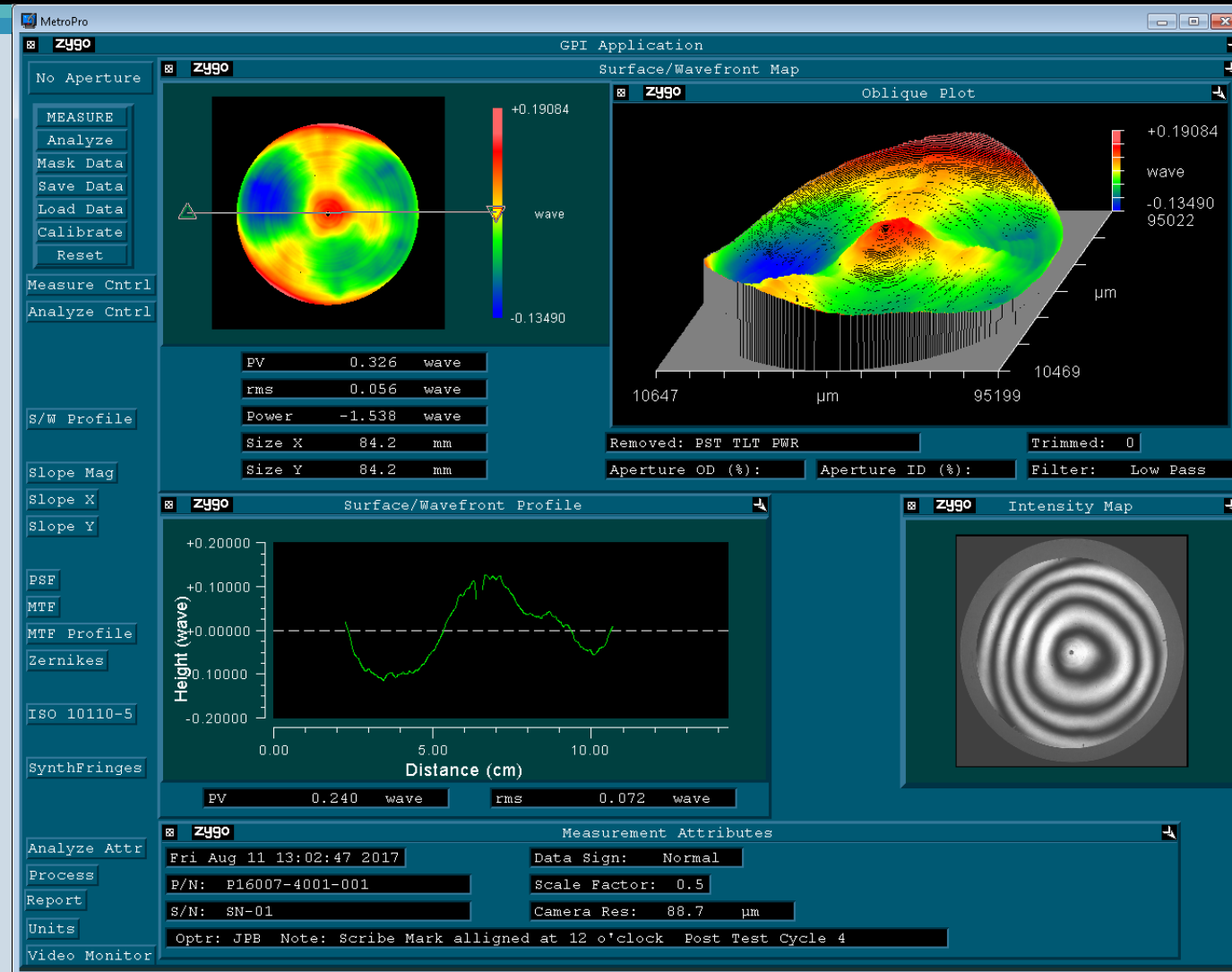

Monolithic Mirrors – After Thermal Cycling

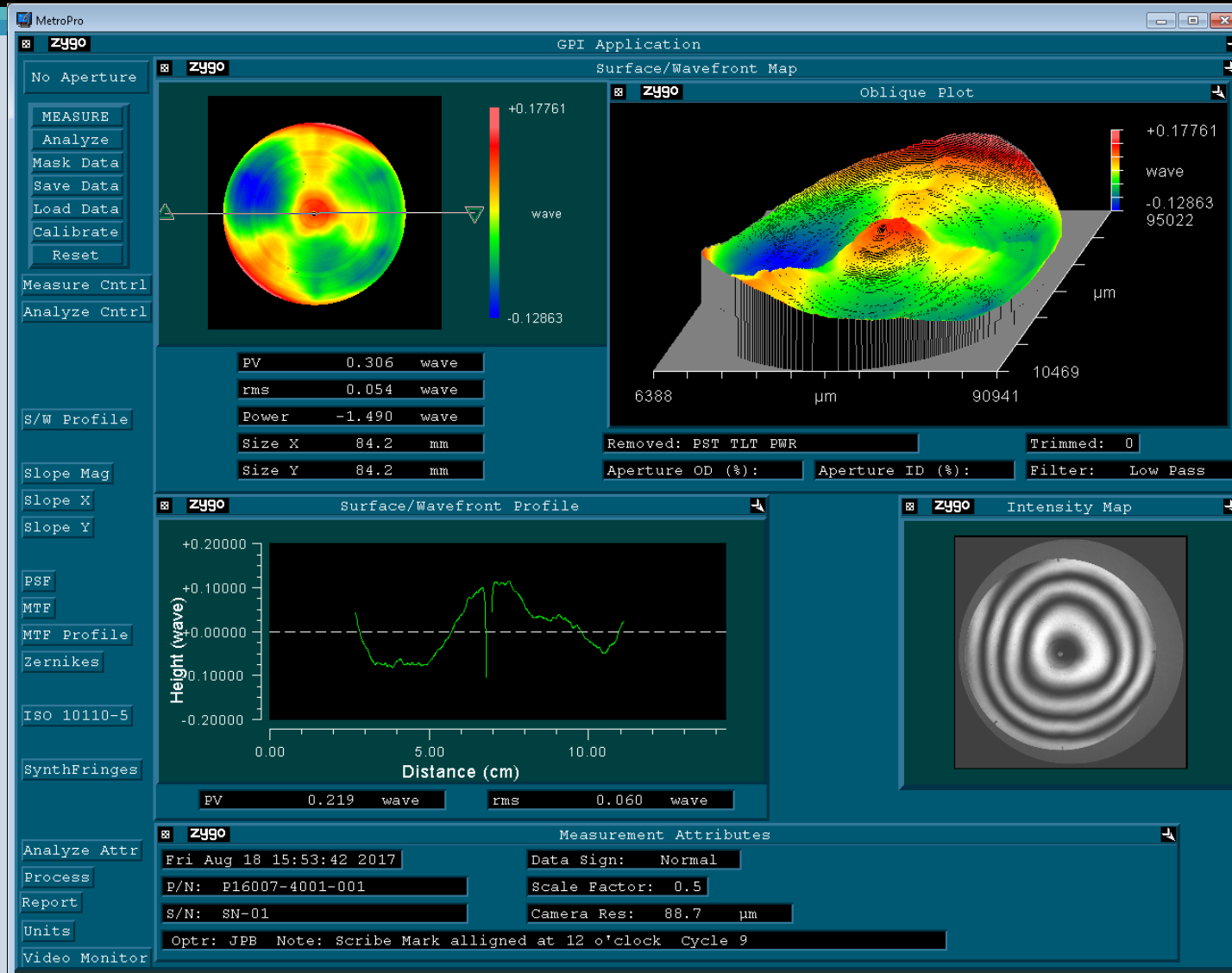

- Showed little movement from baseline to thermally cycled mirrors.
- These mirrors are very stable over long periods of time.
- Everything is somewhat unstable; it degrades at some level over time.
- Goal would be to have the system operate over a wide temperature range.
- We want a usable system that is cost effective.

Segmented Mirrors

Manufacturing Flow Chart

(Major Steps for LID Bonded Mirrors)

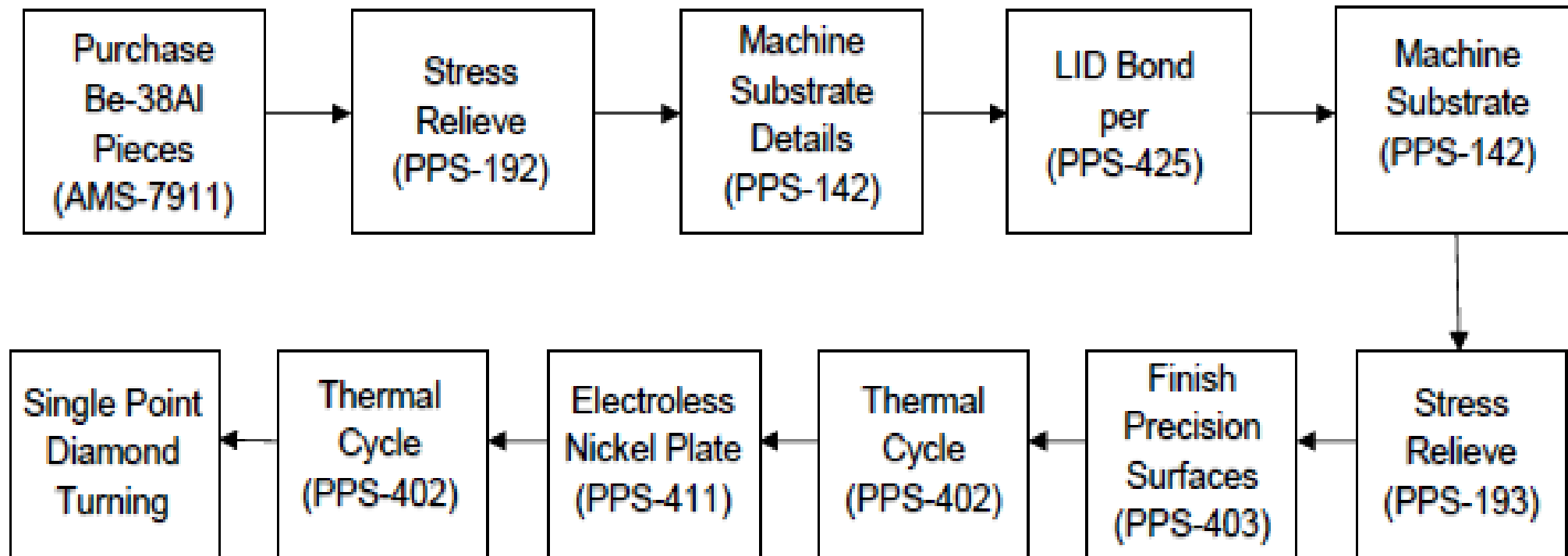

Segmented Mirrors – Baseline

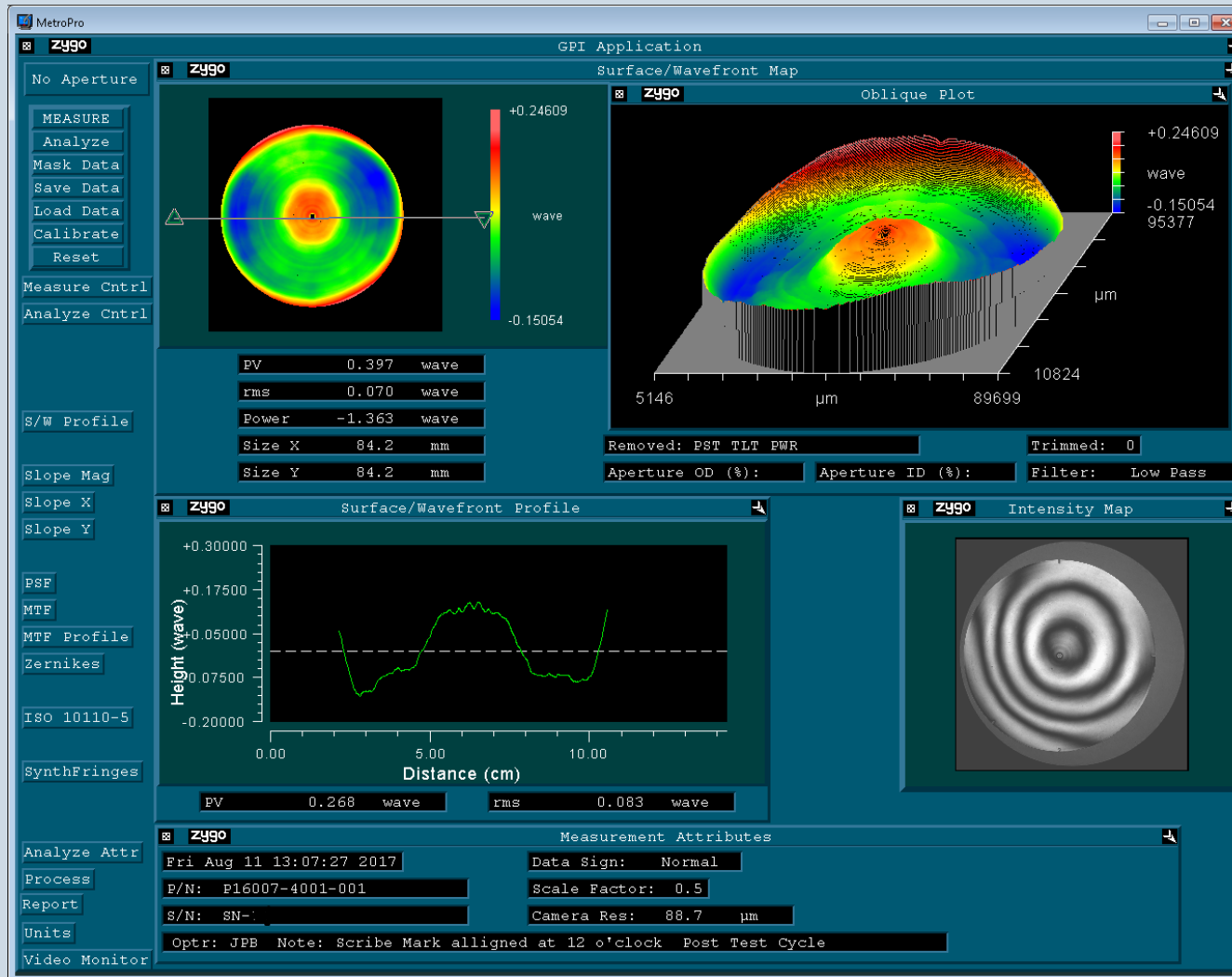

Segmented Mirrors – After Thermal Cycling

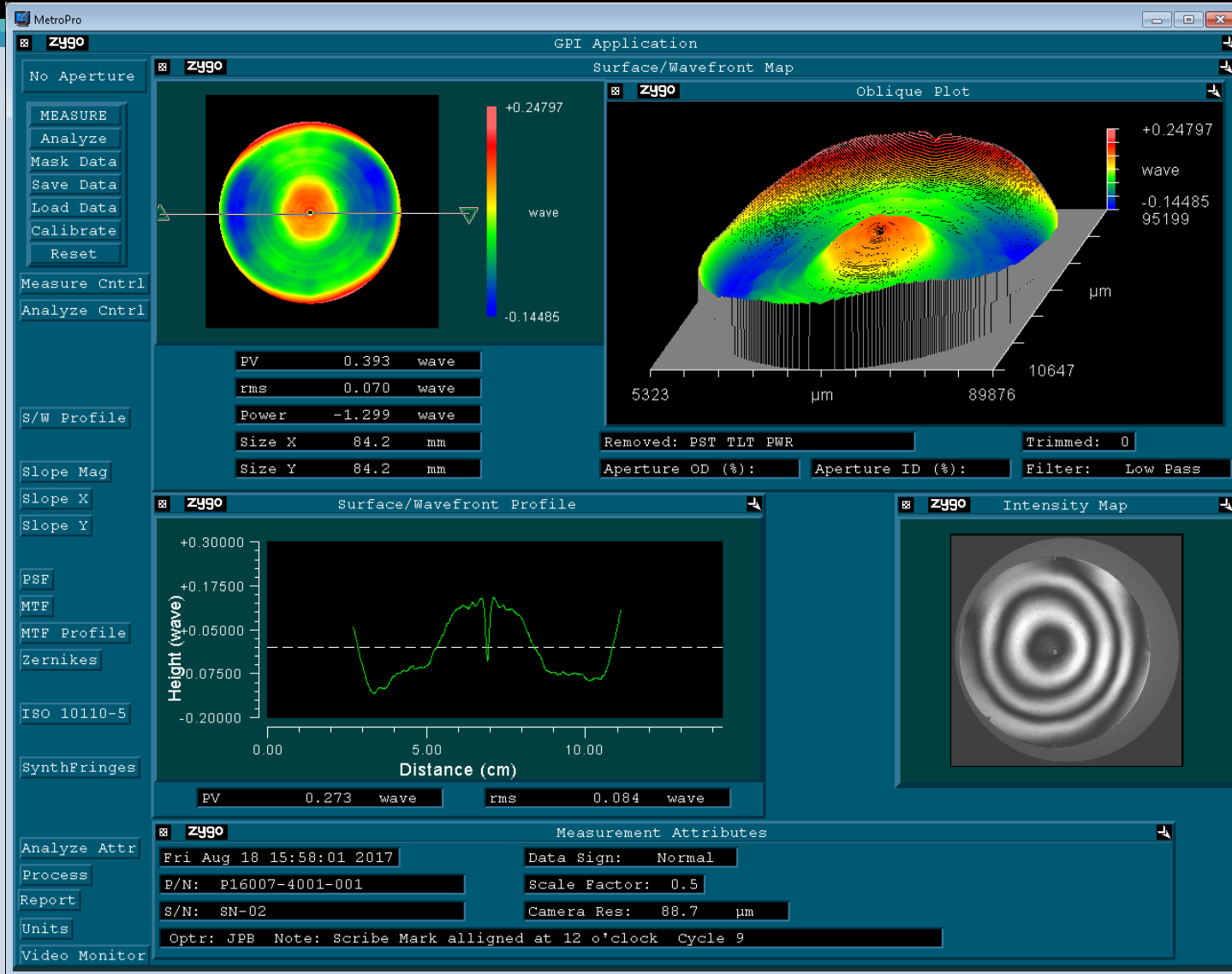

The LID bonded, segmented mirror produced more stability than the monolithic mirror. It was able to withstand higher temperatures over longer periods of time.

Integrated Polish

Monolithic

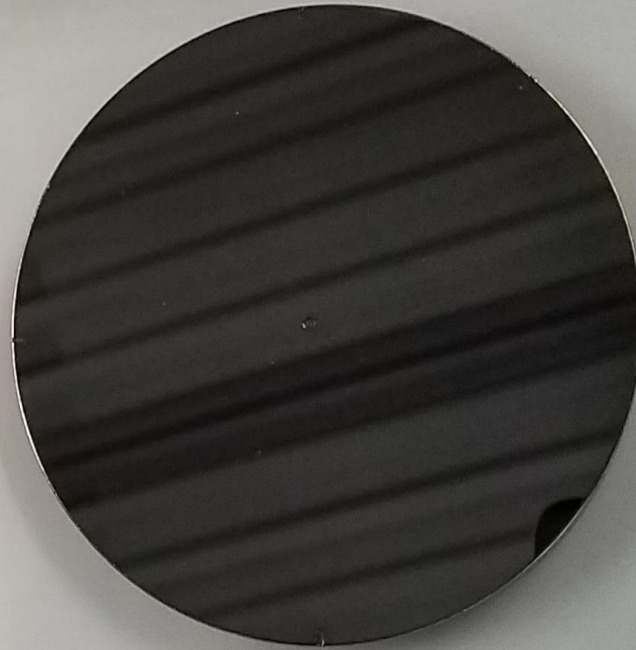

Segmented

Because of its success, we want better resolution on movements through the use of re-polishing the optics to get to an even finer finish before we retest them.

This should yield even better results.

Test Data – 90 mm Polished Monolithic Mirrors

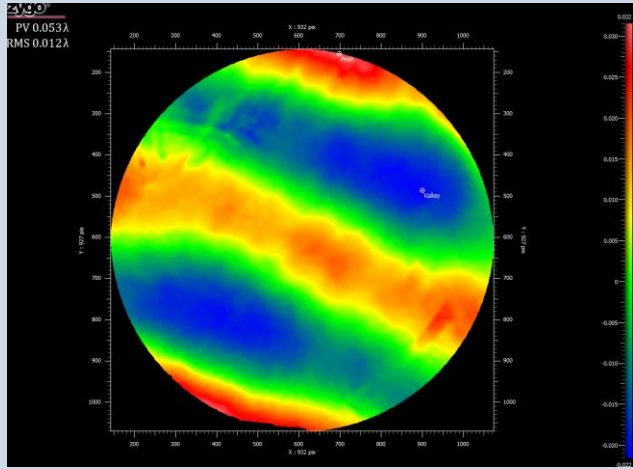

Cycled to 0°C

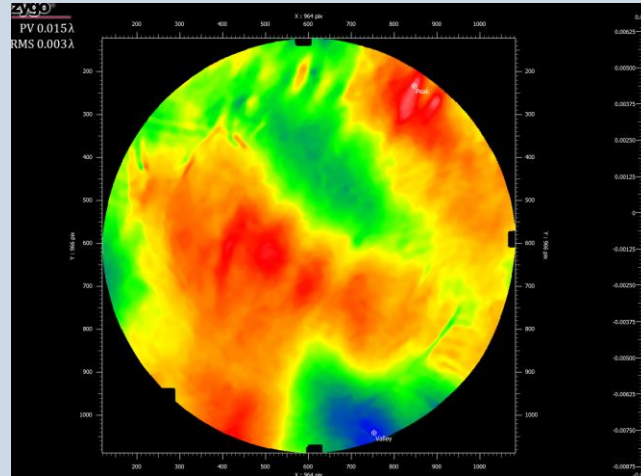

Cycled to -20°C

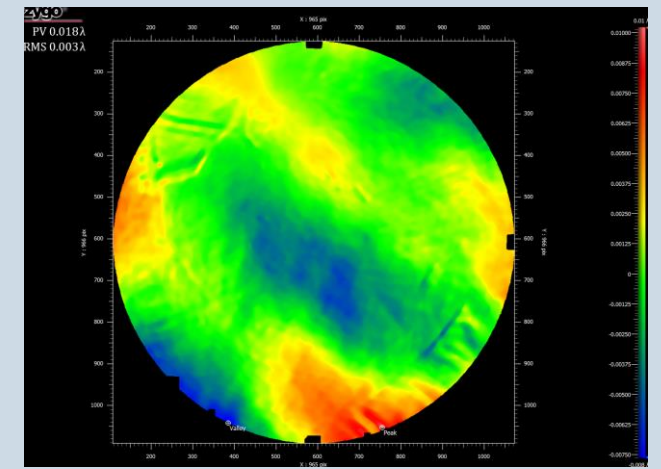

Cycled to -40°C

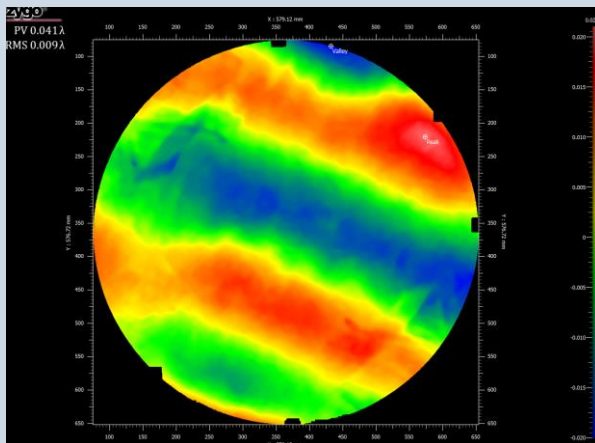

Cycled to -60°C

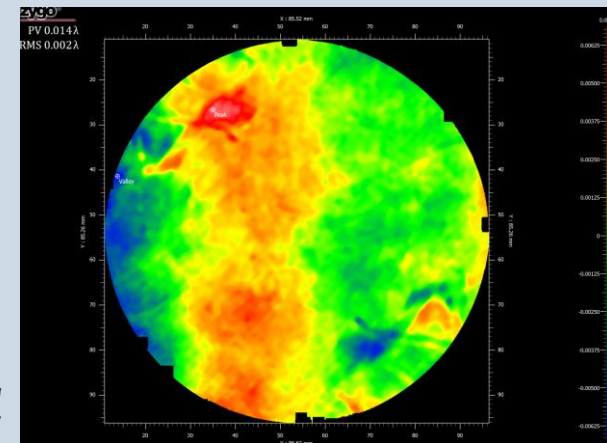

Cycled to -72°C

Test Data – 90 mm Polished Segmented Mirrors

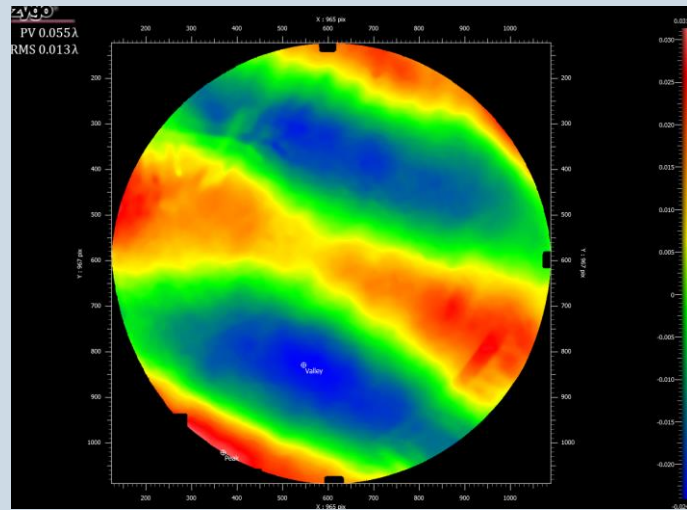

Cycled to 0°C

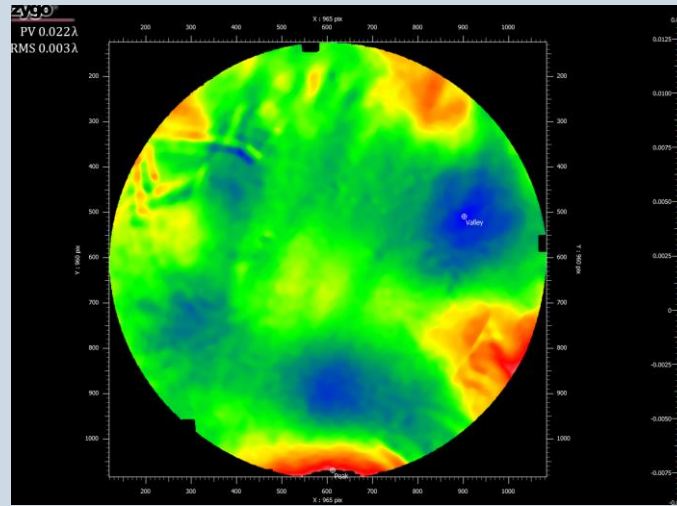

Cycled to -20°C

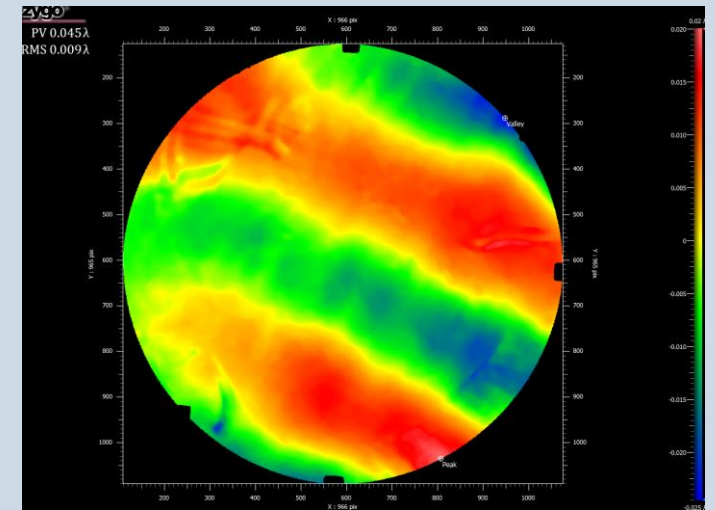

Cycled to -40°C

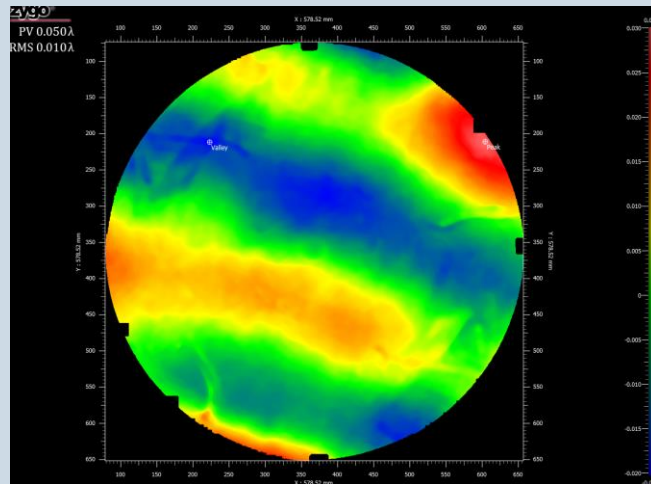

Cycled to -60°C

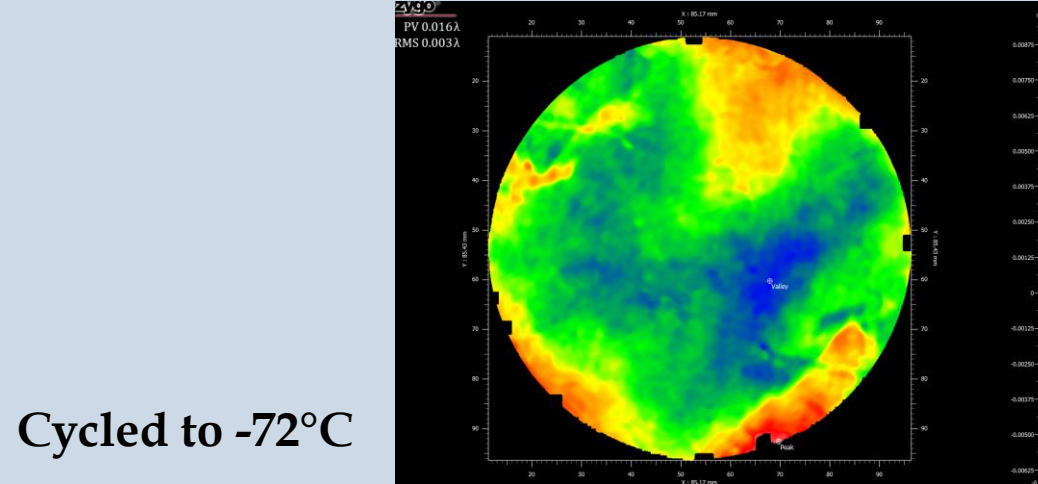

Cycled to -72°C

1/2 m Sized Optics



Stress at 10g Loading

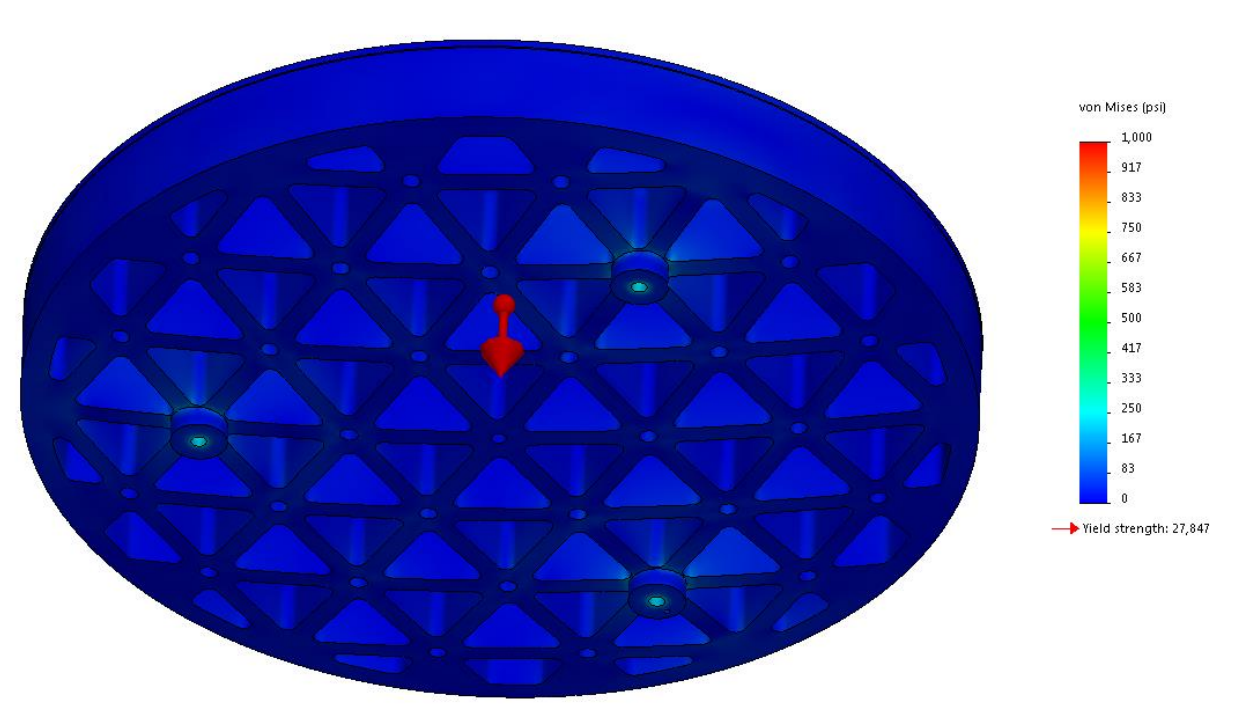

Initial Monolithic 1/2 m Design based on JWST Mirrors

1/2 m Sized Optics

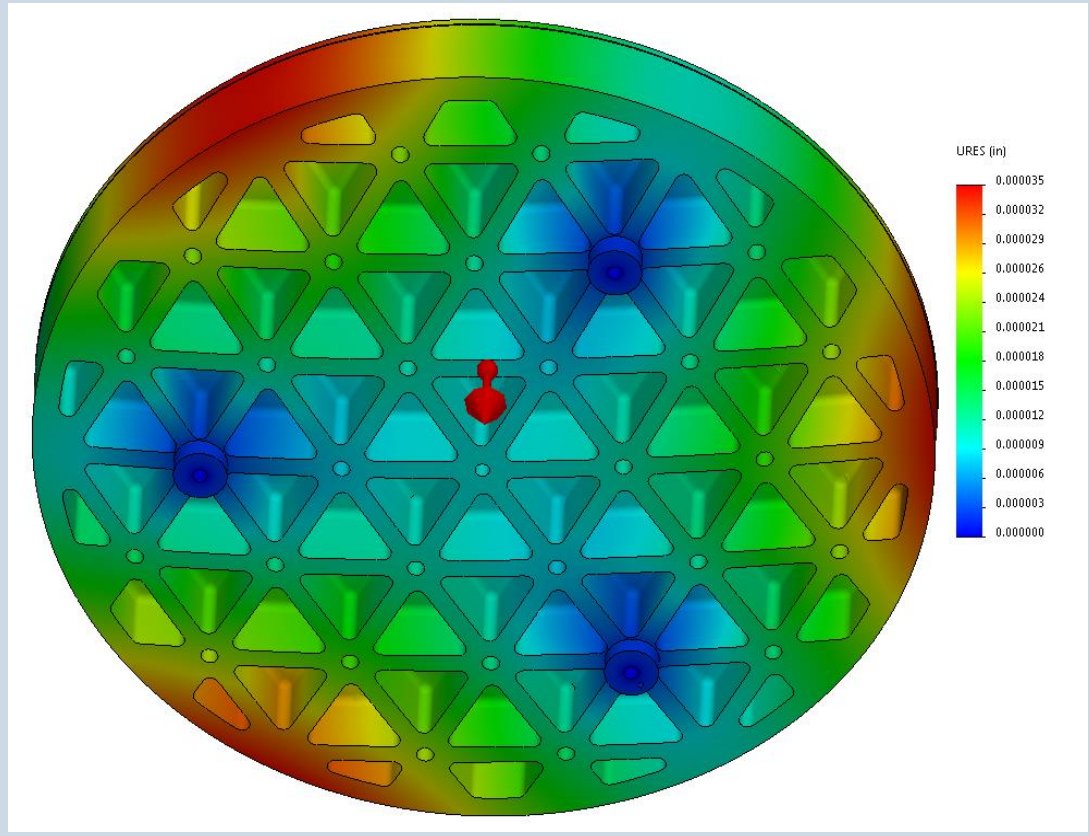

Deflection at 10g Loading

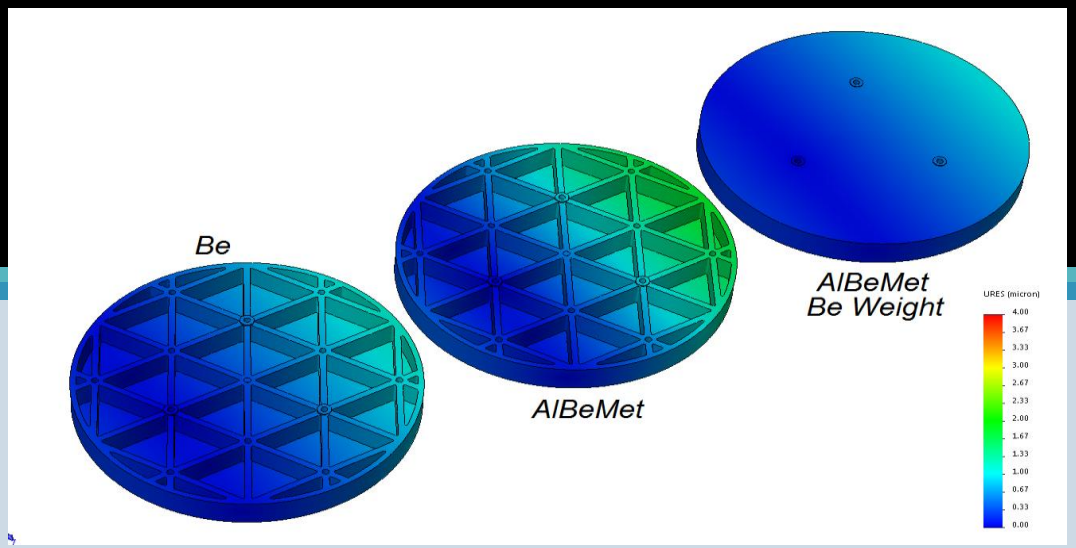

Equivalent Weight Designs, The Closed Back Be-38Al Design is Equal to Weight and Stiffness to the Beryllium Design on the Left

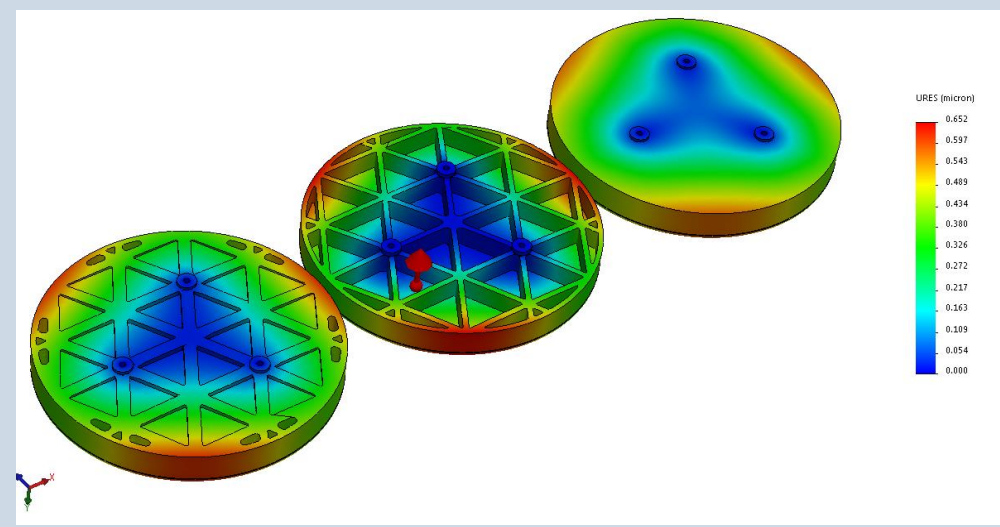

Various Design Scenarios were Explored

Monolithic Mirrors

Substrate Fabrication for Monolithic Be-38Al Mirrors

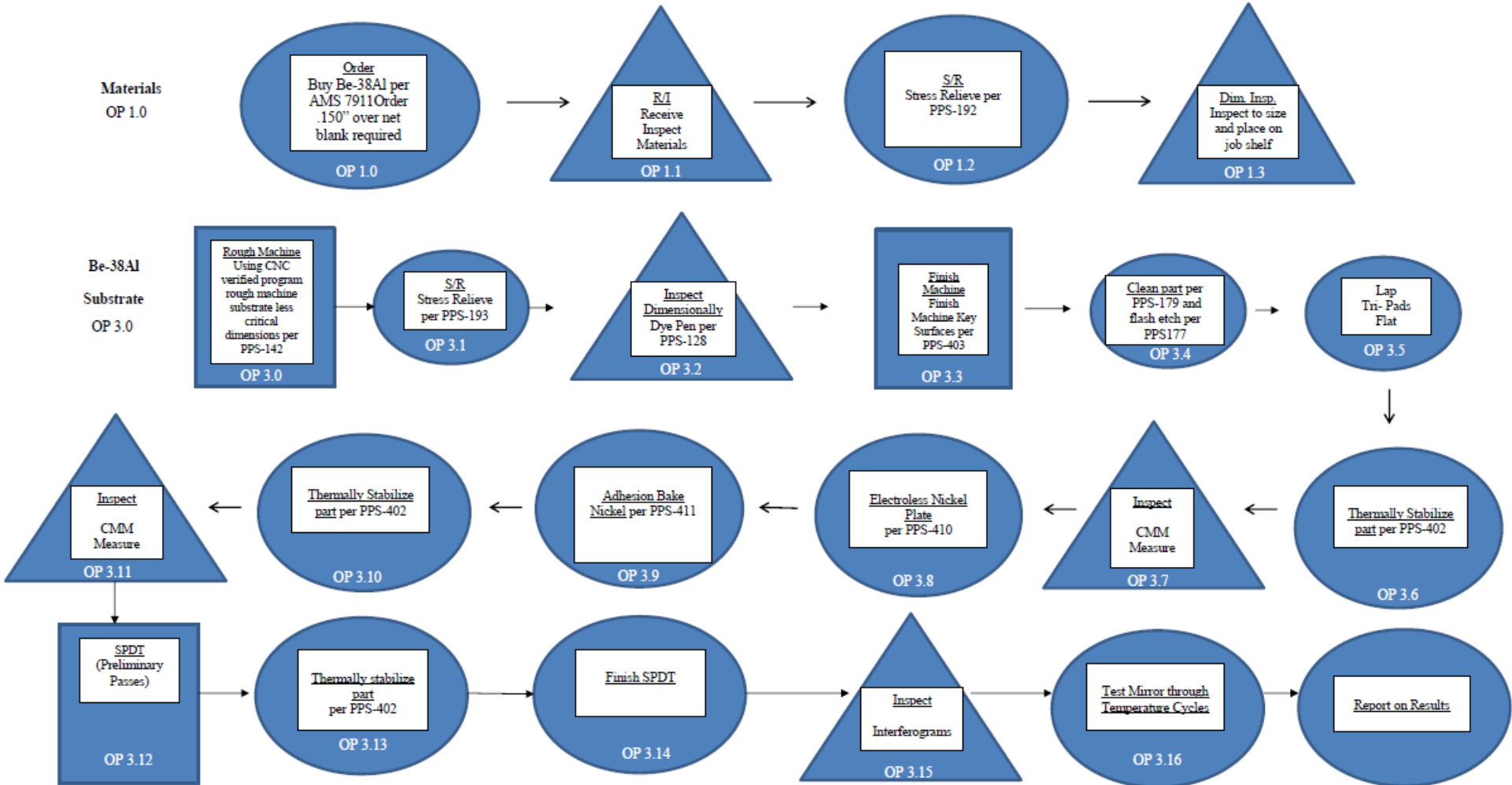

1/2 m Optic – Monolithic Mirror

BASELINE

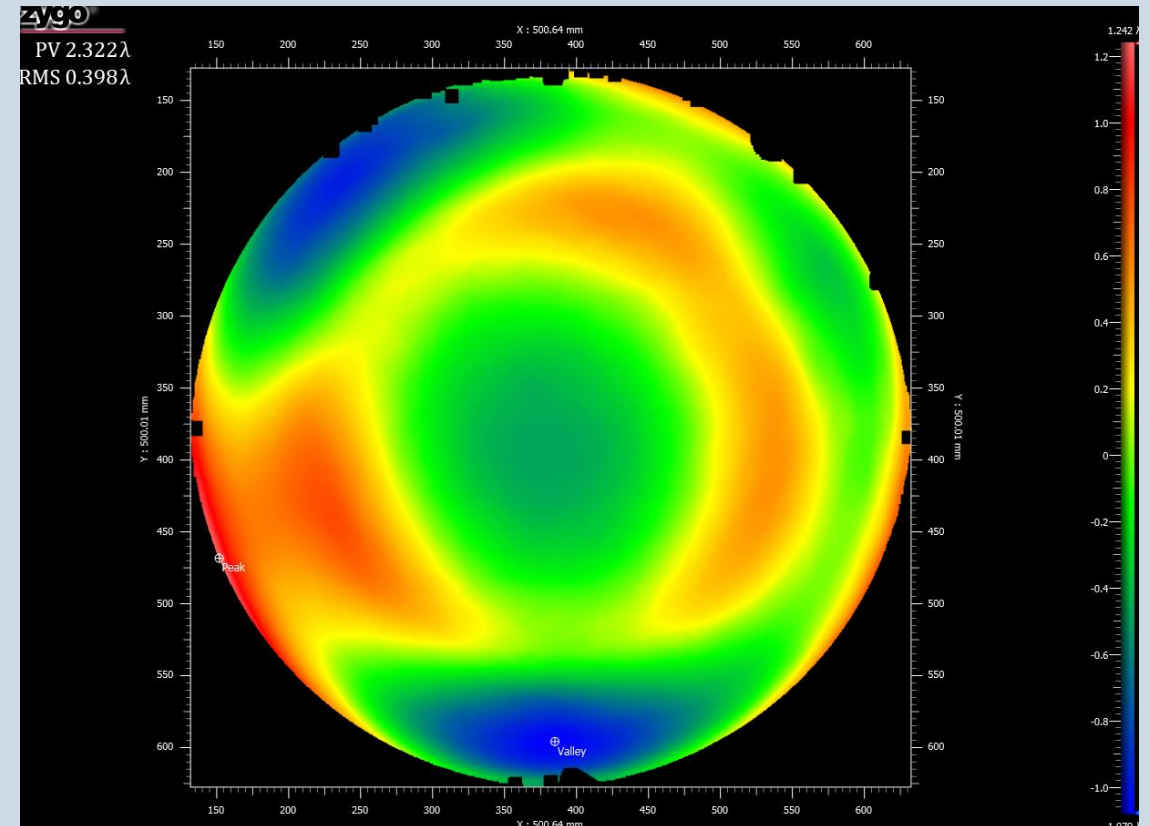
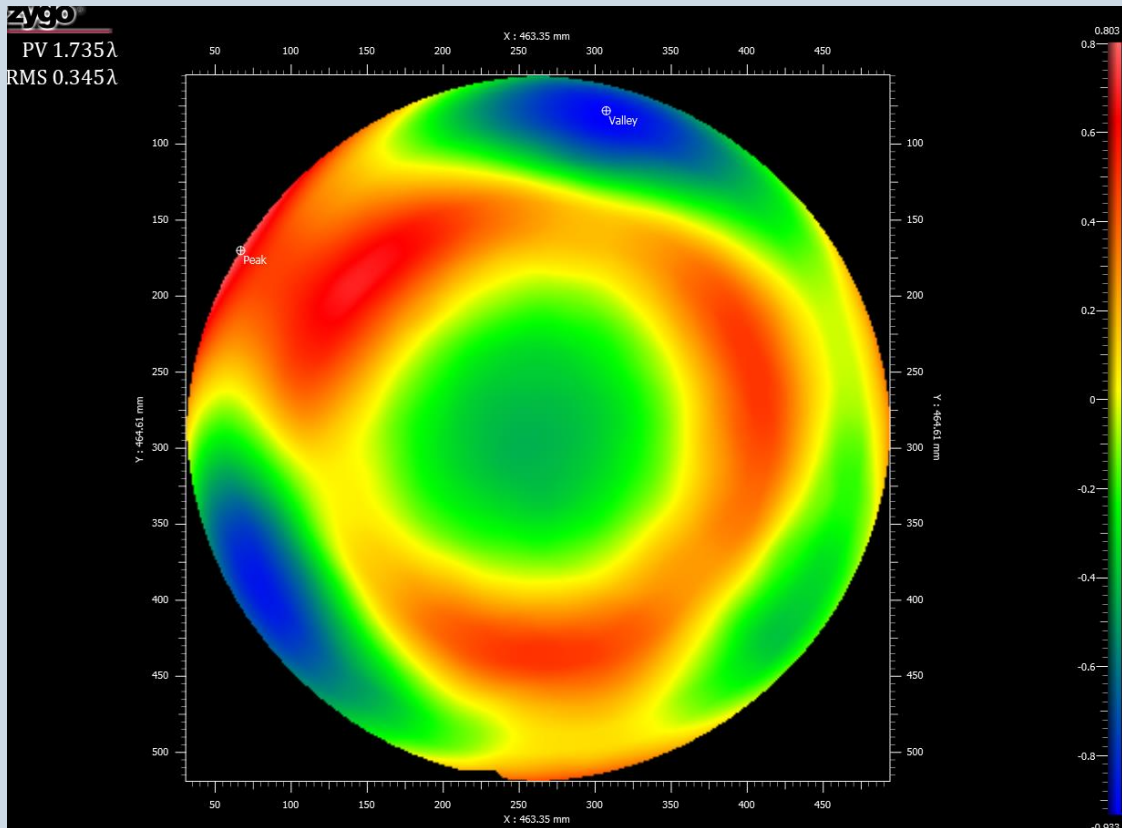

AFTER ALL THERMAL CYCLING

Segmented Mirrors

Substrate Fabrication for LID Bonded Be-38Al Mirrors

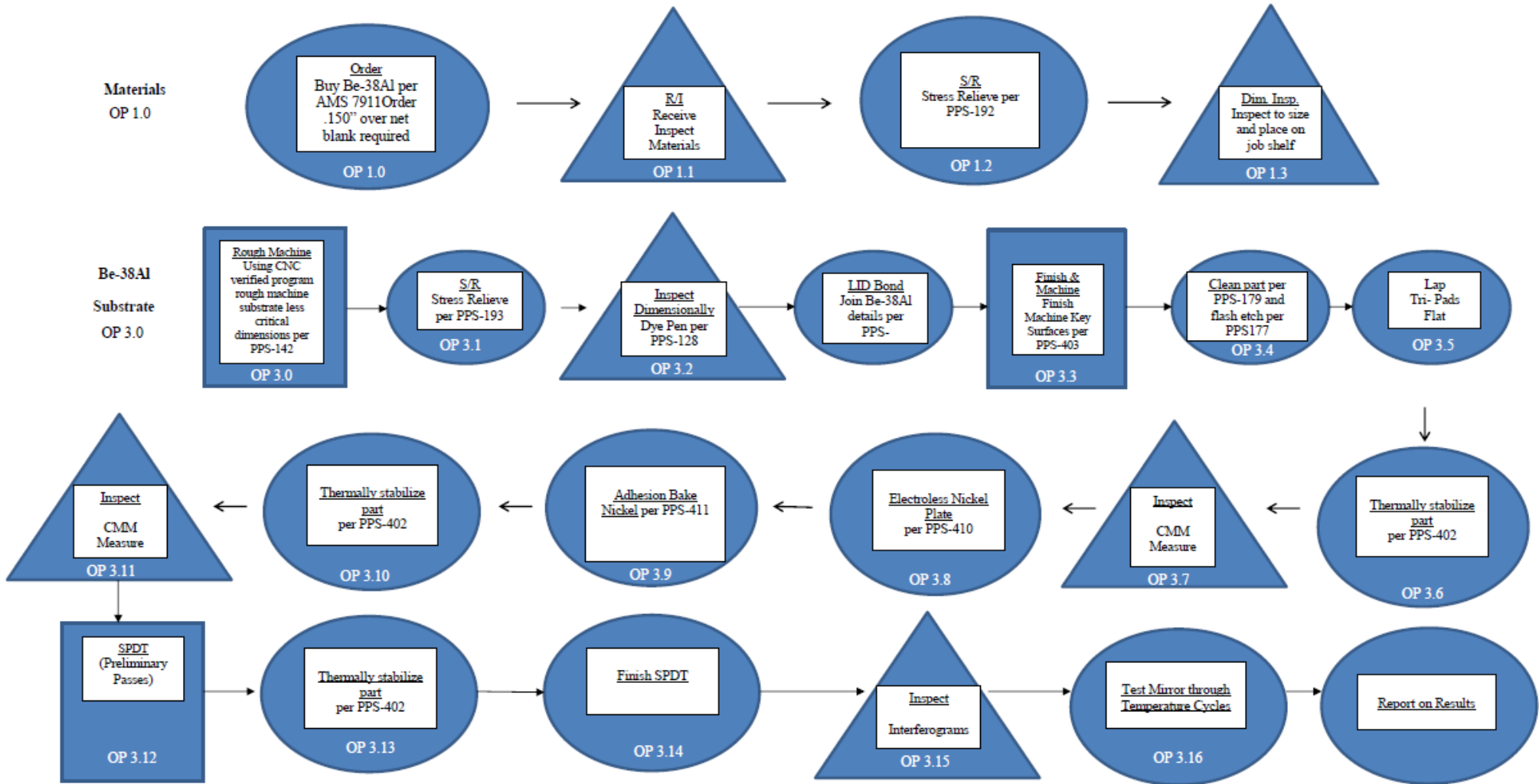

1/2 m Optic – Segmented Mirrors

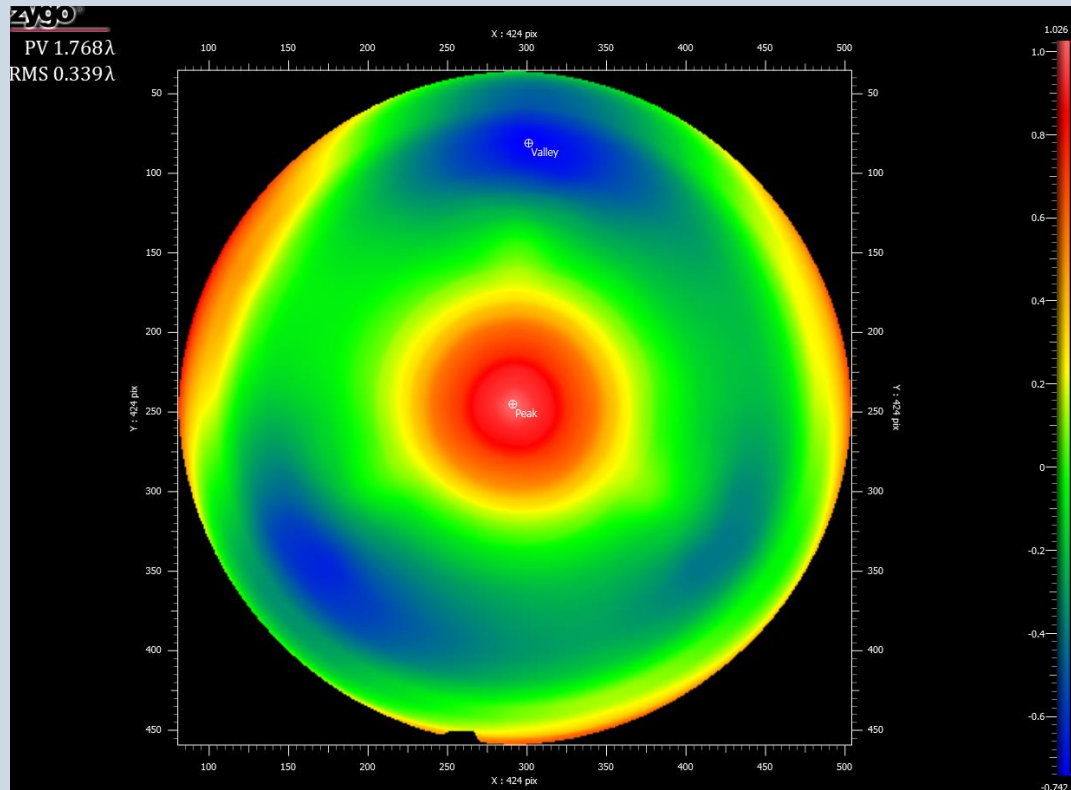

BASELINE

AFTER THERMAL CYCLING AT LOW TEMPS.

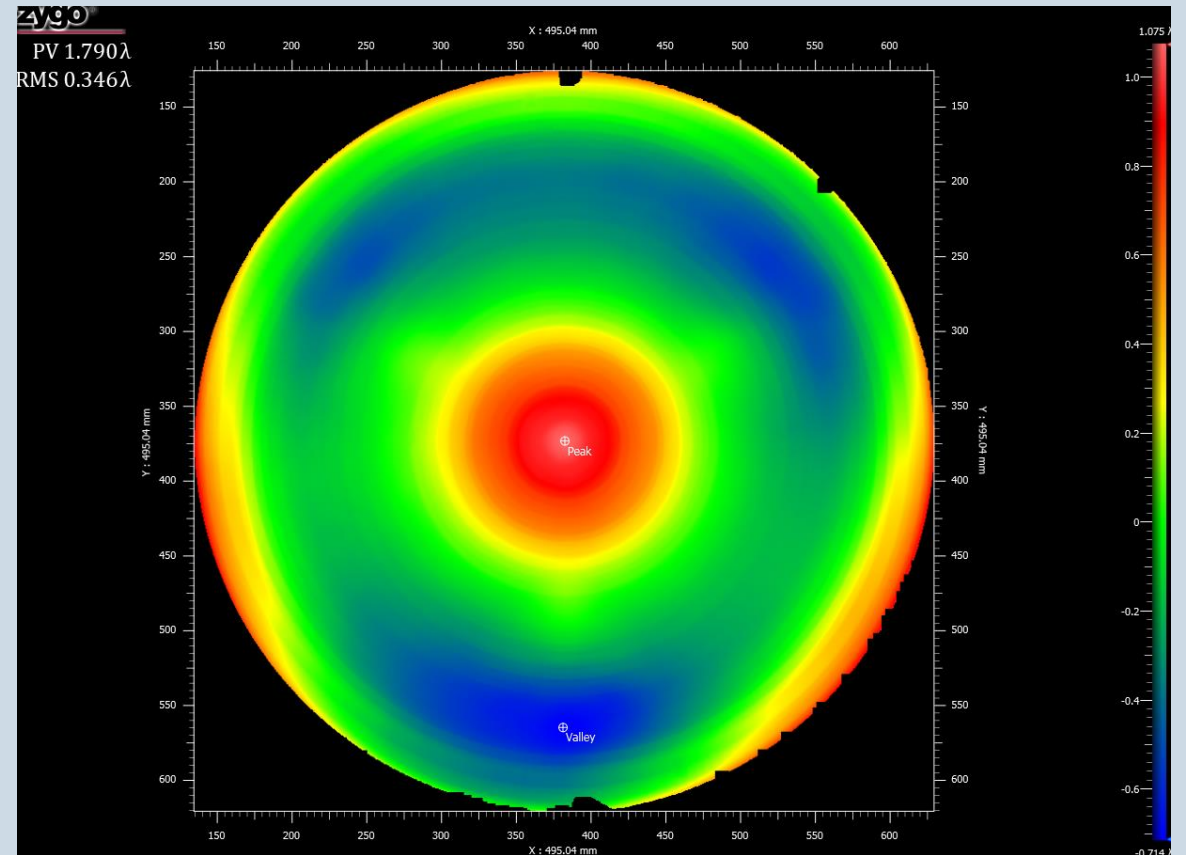

Hardware (1/2 m Mirrors)

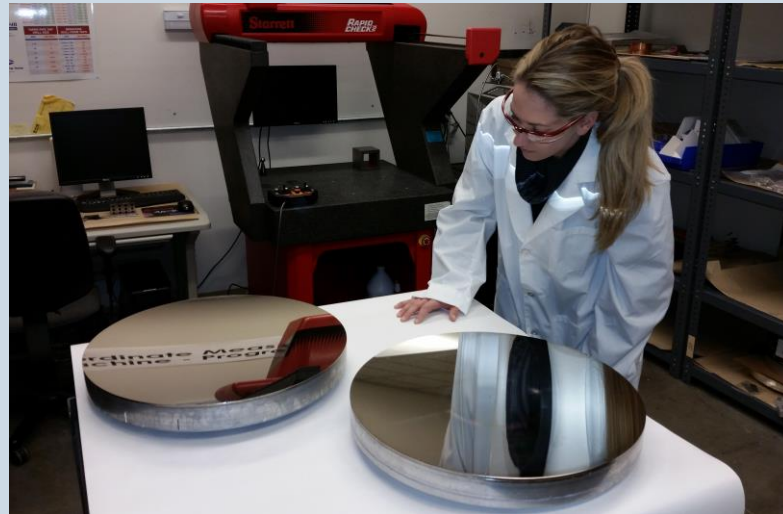
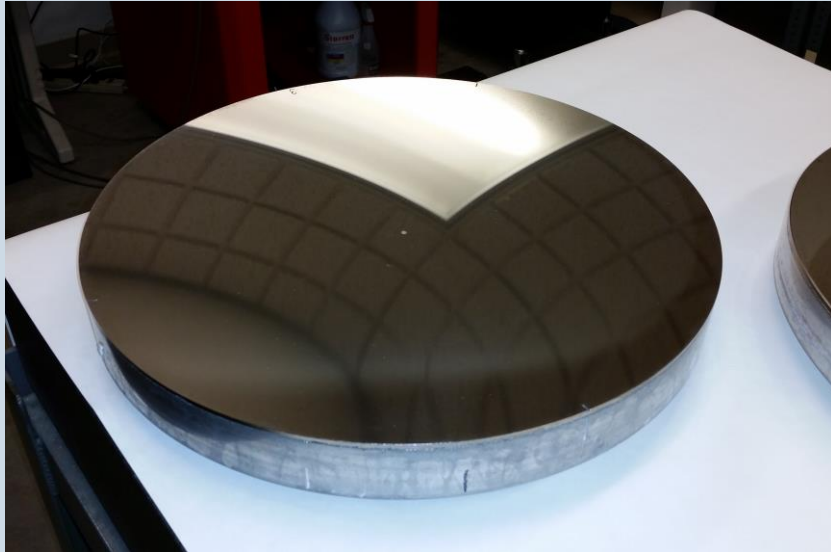
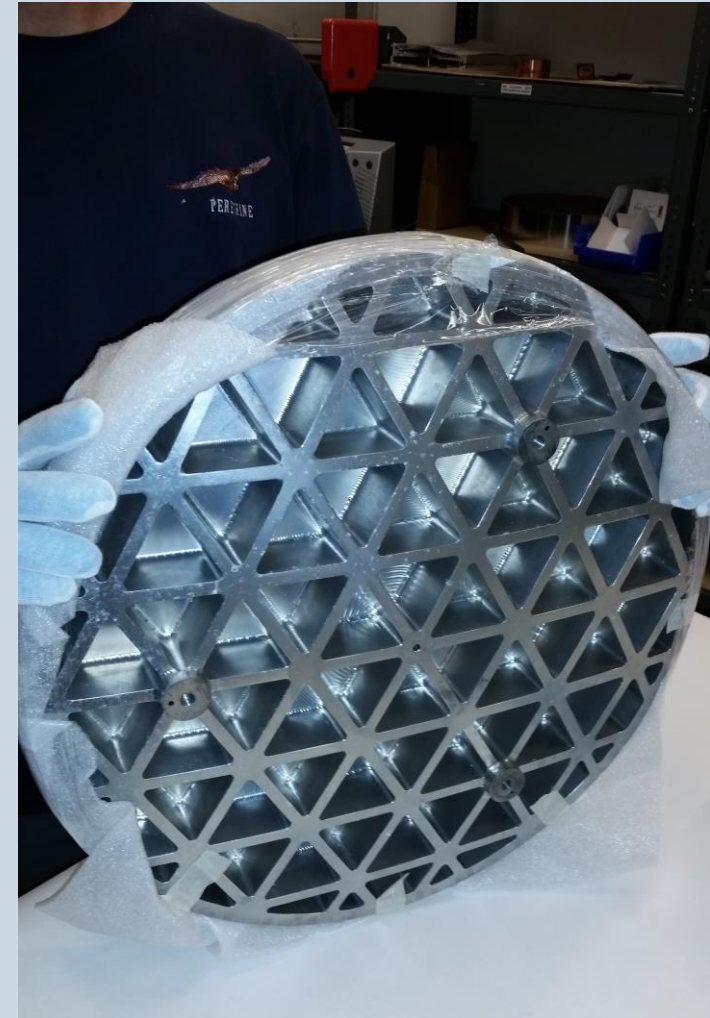
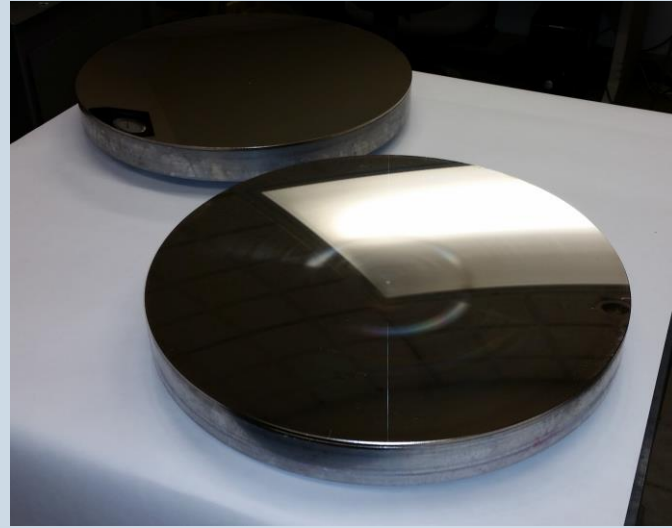
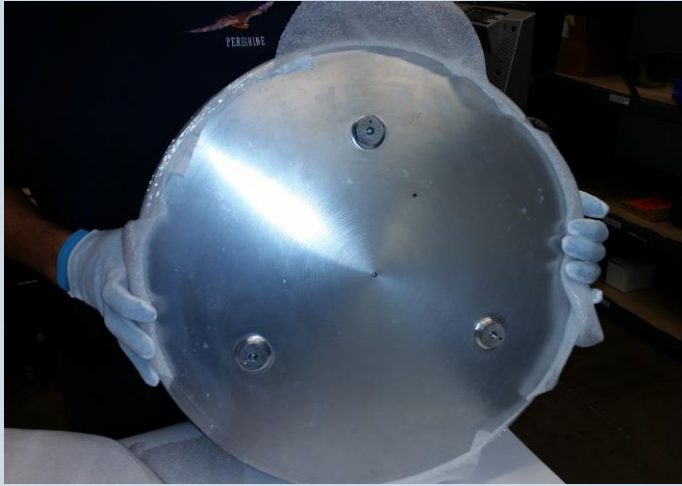



Advanced Mirror Material System

PI Robert Hardesty



Objectives

- Develop a Material System that can:
 - Reduce the cost of mirrors by a factor of 4 from \$6.5M/m², while minimizing production time in half.
 - Maintain stiffness, low density, stability and performance.
 - Produce >4m in size.
 - Match CTE of Electroless Nickel to Be-38Al substrate by controlling Phosphorous content.
 - Operate across wide temperature ranges down to low temperature.

Advanced Mirror Material System



Be-38Al / LID Bonding / Electroless Nickel Plating (CTE Matching) / SPDT- Polished

Testing demonstrates stability to 1/50th λ

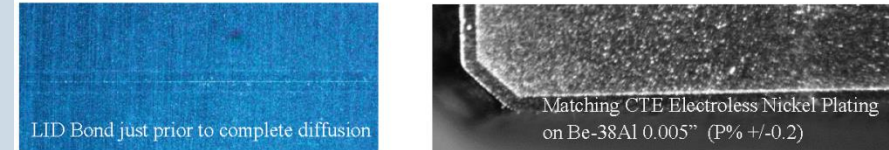

Future Planned Developments

Planned Post Phase II Partners

Peregrine has the ability to produce mirrors using this technology – however, we seek Partnerships on a program by program basis.

Planned / Possible Mission Infusion

1. CIBER-2 a Sounding Rocket Telescope application for 80K operation.
2. Visible to MWIR Imaging System for Military application.

Planned / Possible Commercialization

After initial key applications development, we plan to pursue scan mirrors and Earth Observation Athermal Systems.

Accomplishments

- Matched (WI +/- .2%P) Electroless Nickel (EN) Plating to Be-38Al to yield a stable substrate.
- Seamlessly joined Be-38Al together that can create large substrates for mirrors (no surface indication).
- Demonstrated stability to 1/50th λ.
- Successfully tested across large temperature ranges down to low temperatures.
- Delivered two half meter mirrors (Monolithic and LID bonded versions) using SPDT at an areal cost of <<\$1M/m².

Key Milestones Met:

- Dialed in Electroless Nickel Plating process to +/- .2%P.
- Dialed in Liquid Interface Diffusion Bonding process for seamless joints.
- Integrated Be-38Al/LID Bond/EN/SPDT to create stable substrates.
- Tested Material System over wide temperature range to low temperatures.