



# Automated Management of Small Unmanned Aircraft System Communications and Navigation Contingency

Jaewoo Jung<sup>1</sup> and Sreeja Nag<sup>2</sup>

*NASA Ames Research Center, Moffett Field, CA 94035, USA*

**NASA has been pioneering research and development of technologies and requirements for the traffic management ecosystem for Unmanned Aircraft (UA) that complements the FAA's Air Traffic Management system under the Unmanned Aircraft System (UAS) Traffic Management (UTM) project. In this effort, the FAA, industry, and academia developed nine requirements for managing Communications and Navigation (C&N) off-nominal situations, as nominally functioning C&N systems are essential for safe UA operations. The requirements were reviewed by the UTM community and practiced during NASA's UTM flight demonstration in 2019. Some of the requirements could not be fulfilled during the demonstration, and recommendations to automate the management of C&N contingency are made to improve the fulfillment of requirements. The recommendations include the standardization of the means to detect C&N off-nominal situations and the integration of the UAS and UAS Service Supplier off-nominal mitigation process.**

## I. Introduction

In the USA, Visual Line-of-Sight (VLOS) operations of small Unmanned Aircraft System (sUAS) are commonplace and several types of operations that require approval, such as night operations and operations over people, are becoming routine with the upcoming rulemaking [1,2]. However, Beyond Visual Line-of-Sight (BVLOS) operations may not become routine until the traffic management ecosystem for Unmanned Aircraft (UA) that complements the FAA's Air Traffic Management system is in place [3,4]. NASA has been pioneering research and development of technologies and requirements for this ecosystem under the UAS Traffic Management (UTM) project since 2014, and the term "UTM" has become synonymous with the complementary ecosystem [5,6].

NASA's UTM effort consists of a series of Technical Capability Levels (TCL) activities that are increasingly complex. In TCL1, completed in 2015, VLOS operations such as agriculture, firefighting, and infrastructure monitoring were addressed with a focus on geofencing and operations scheduling [7]. Technologies and requirements for BVLOS operations in sparsely populated areas were examined in TCL2 in 2016, and for those operations over moderately populated areas in TCL3 in 2017 and 2018 [8,9,10]. TCL4 built on the earlier TCLs and focused on operations in higher-density urban areas for tasks such as newsgathering and package delivery, and for managing large-scale contingencies.

Throughout the TCL activities, sUAS operations encountered Communications and Navigation (C&N) off-nominal conditions, such as loss of Command and Control (C2) communications link and degraded navigation performance [11,12]. Since nominally functioning C&N systems are essential for safe UA operations, a working group consisting of NASA, the FAA, the industry and academia members developed an approach to handle C&N off-nominal events. This paper describes a set of C&N contingency management requirements that comes from the working group's effort and the UTM community response to the requirements in Section II. The details of requirements practice during the TCL4 demonstration are in Section III. Some requirements were not fulfilled in the demonstration and Section IV provides guidance for automating contingency management to improve requirements fulfillment. The paper concludes in Section V.

<sup>1</sup> Aerospace Technologist, Aviation Systems Division, Senior Member.

<sup>2</sup> Research Scientist, Bay Area Environment Research Institute.

## II. Communications and Navigation Contingency Management Requirements

### A. C&N Working Group and Requirement Development

To coordinate and facilitate the incremental implementation of the UTM in the National Air Space (NAS), NASA and the FAA formed a Research Transition Team (RTT) in 2017 [13]. The team is divided into four working groups, Concept and Use Case Development, Data Exchange and Information Architecture, Sense and Avoid, and C&N. The industry and academia were invited to participate in the last three working groups. The C&N working group, whose objective is to explore communications and navigation solutions to ensure that UA is under the operational control of the operator and remain within a defined area, led the discussion on off-nominal situations and development of C&N contingency management requirements.

As the C&N working group formed, NASA sent out an input request<sup>3</sup> to gather the group's view on C&N system performance. Twenty organizations provided the input, which was discussed in a series of meetings. From these discussions, the following insights were developed. First, the C&N system performance must reflect operational complexity. For example, UA flying among many other UA and manned aircraft over a densely populated area requires higher C&N system performance than a single UA flying over a barren area. Second, communications between UA and its operator can be disrupted especially when the protected aviation spectrum is not used. The cause of this disruption includes intentional or unintentional radio frequency (RF) interference and blocked radio line of sight (e.g., a building between UA and its operator) [14,15]. Third, given the prevalent use of Global Navigation Satellite System (GNSS) receiver, such as the Global Positioning System (GPS), in the UA navigation system, navigation performance can be degraded due to RF interference, blocked radio line-of-sight to GNSS satellites, and reflected satellite signal (i.e., multipath) especially in low-altitude environments [16,17]. It was understood that disrupted communications and degraded navigation performance situations pose a risk to safe UA operations.

The C&N working group applied the insights about the C&N system performance and off-nominal situations to develop contingency management requirements. Operator participation in UTM was assumed as a part of the contingency management [6]. In particular, operators were expected to use UAS Service Supplier (USS) to coordinate multiple BVLOS operations in the same geographical area, be informed of the NAS constraints, inform the FAA of UA operation issues that could impact the NAS operation, and manage off-nominal situations [18]. The role of USS is shown in Fig.1, UTM architecture. Table 1 shows nine C&N contingency requirements. The keywords "MUST" and "SHOULD" in the requirements should be interpreted as described in BCP 14 [RFC2119] [RFC8174].

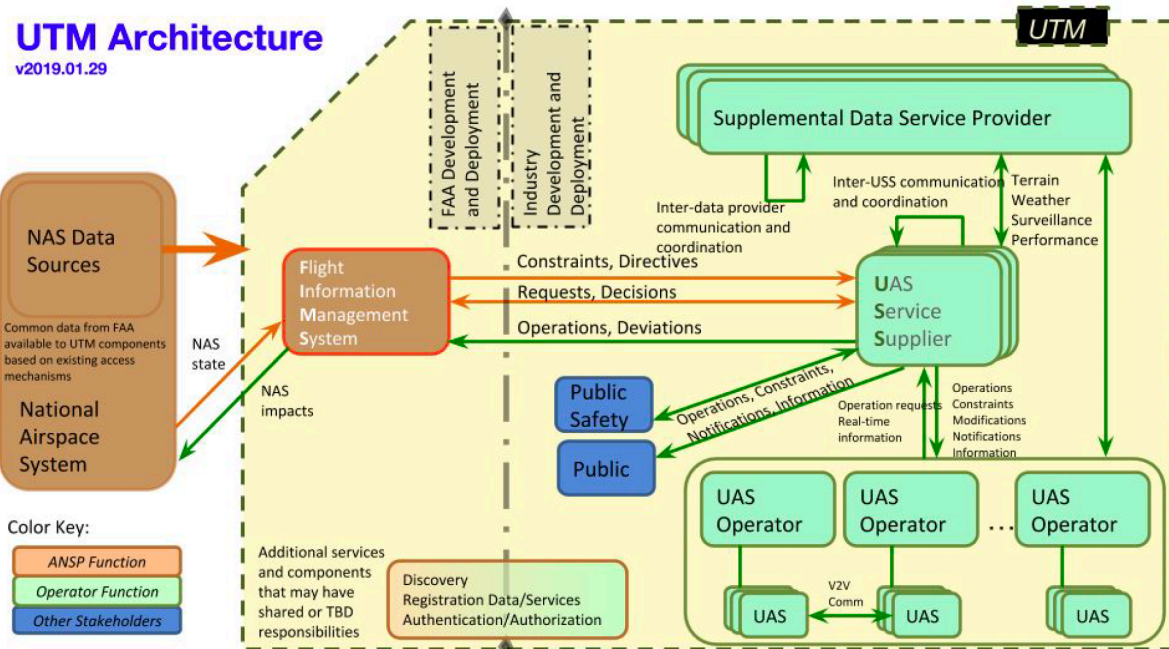

Fig. 1 UTM Architecture, January 2019

<sup>3</sup> Additional information about this input process is in Appendix A.

**Table 1 C&N Contingency Management Requirements**

<b>Req. ID<sup>4</sup></b>	<b>Requirement Text</b>	<b>Requirement Justification</b>
OSM.001	The operator <b>MUST</b> have the means to detect loss of communication between aircraft and its operator.	The UTM system is built for operators to perform missions within constraints and directives that can change over time. Therefore, operators must know whether they can communicate or not with their UA to adhere to dynamic constraints and directives.
OSM.002	The operator <b>SHOULD</b> make the means to detect loss of communication with aircraft known to USS.	USS, with appropriate data from Supplemental Data Service Provider (SDSP), should be able to provide communications quality of service information for a mission when the means to detect loss of communication is known. This will likely reduce the loss of communication incidence during a mission.
OSM.003	The operator <b>MUST</b> define steps to mitigate the loss of communication with aircraft.	Operators must communicate with their UA to adhere to constraints and directives, which can change during a mission. Therefore, mitigation steps must be in place to resolve the loss of communication safely.
OSM.004	The operator <b>SHOULD</b> make the steps to mitigate the loss of communication with aircraft known to USS.	USS, with similar information from other operators and adjacent USSs, should be able to support mitigation steps with minimal impact on overall operations under its service.
OSM.005	The operator <b>MUST</b> have the means to detect loss of aircraft onboard navigation.	The UTM system is built for operators to perform missions within constraints and directives. Therefore, when UA is not maintaining the necessary navigation solution accuracy and integrity to adhere to constraints and directives, the operator must know this condition.
OSM.006	The operator <b>SHOULD</b> make the means to detect loss of aircraft onboard navigation known to USS.	USS, with appropriate data from SDSP, should be able to provide navigation service quality forecast for UAS mission when its means to detect loss of navigation is known. This will likely reduce the loss of navigation incidence during a mission.
OSM.007	The operator <b>MUST</b> define steps to mitigate the loss of aircraft onboard navigation.	UA must maintain the necessary navigation solution accuracy and integrity to adhere to constraints and directives. Therefore, mitigation steps must be in place to resolve the loss of navigation safely.
OSM.008	The operator <b>SHOULD</b> make the steps to mitigate the loss of aircraft onboard navigation known to USS.	USS, with similar information from other operators and adjacent USSs, should be able to support mitigation steps with minimal impact on overall operations under its service.
OSM.009	The operator <b>MUST</b> collect off-nominal situation data.	When UTM operations encounter off-nominal situations, data must be collected to take lessons learned to reinforce operational compliance and to enhance operational safety.

<sup>4</sup> OSM stands for Off-nominal Situation Management. This term and the ID number can change as UTM develops and should only be considered for consistency in the paper.

## B. UTM Community Response to the Requirements

In 2018, C&N contingency management requirements and justifications were sent out to the RTT participants with an online survey form for feedback. In the survey, each requirement was restated and the responder was given a scale of one to seven to indicate the applicability of that requirement. A “one” indicates the requirement should not be a requirement of UTM and a “seven” indicates the requirement is reasonable as written and is needed in UTM. The responder was also given three choices to indicate when the requirement should take effect. The choices were 1) When the UTM system achieves Initial Operational Capability, IOC (e.g., TCL1 operations), 2) After the UTM system achieves the IOC but before Full Operational Capability, FOC (e.g., TCL2 operations), and 3) When the UTM system achieves FOC (e.g., TCL3, TCL4 operations). A space to provide additional input was provided in the form.

The survey collected 19 responses, nine from the C&N working group members, five from other RTT working group members, and five from non-members. Of the 19, eleven represented organizations’ view, six represented teams’ and two were personal. Fig. 2 shows applicability for each requirement in a boxplot. The percent of the responses for the three target periods for a requirement to take effect, in IOC, between IOC and FOC, and in FOC, is shown in Fig. 3.

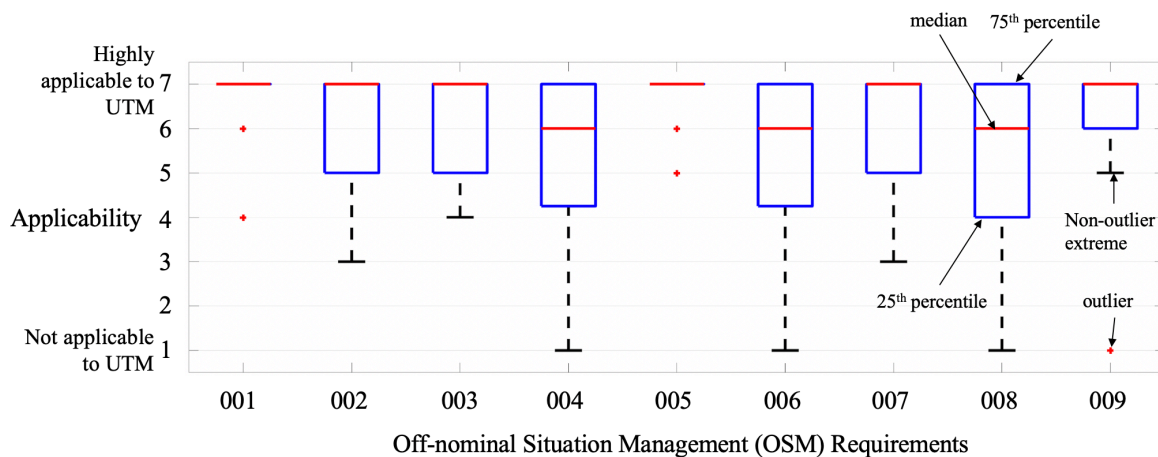

**Fig. 2 OSM Requirements Applicability**

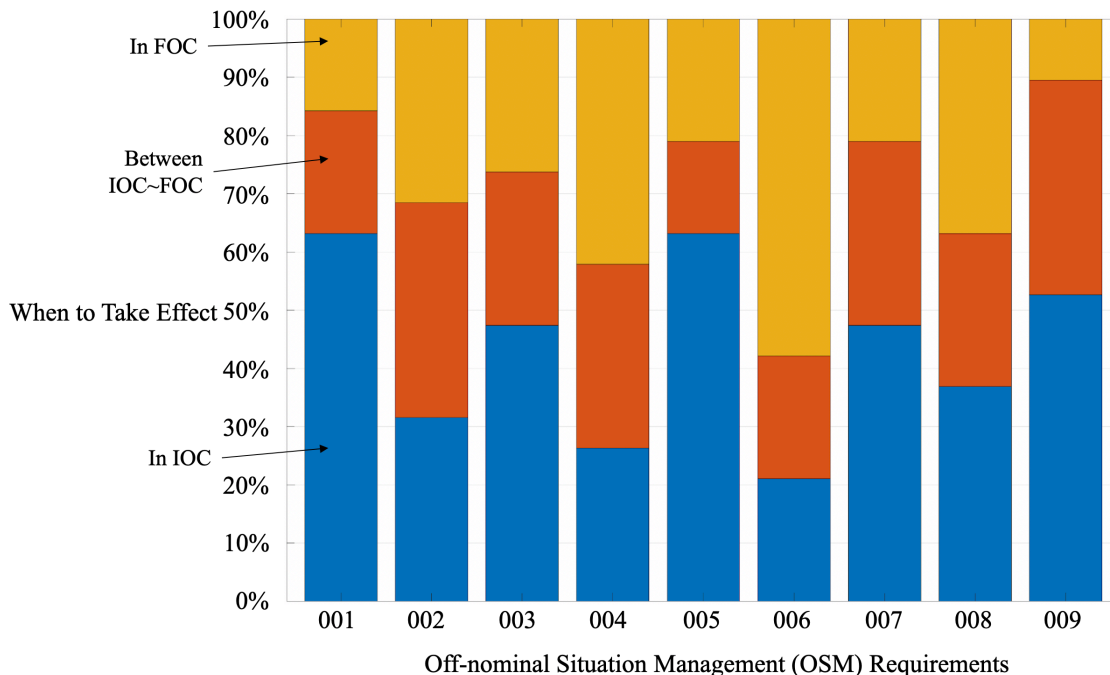

**Fig. 3 Time Period for the OSM Requirements to Take Effect**

The applicability percentiles in Fig. 2 show that all requirements were reasonable as written and needed for UTM, with the median ranging from the lowest 6 to the highest 7. In Fig. 3, a majority of the responses indicated that three requirements, OSM.001, OSM.005, and OSM.009 should take effect in IOC. This showed that off-nominal situation detection and data collection are foundational parts of UTM. The rest of the requirements were deemed to be needed beyond IOC when UTM supports BVLOS operations (e.g., TCL2~4), showing the importance of off-nominal mitigation steps and sharing them with USS for safe and efficient BVLOS operations. A majority of the responses indicated OSM.006 to be effective at FOC. For this requirement, USS should be able to provide navigation service quality forecast with input from SDSP, and the response showed that this capability may not be viable before FOC.

It was also suggested in the feedback that the term “loss of aircraft onboard navigation” used in OSM.005 to OSM.008 should be revised to “degraded navigation performance”. This was to avoid potential misinterpretation of the term for indicating a total loss of navigation capability on a UA, which is not the condition stated in the requirement’s justification text. Given this, “degraded navigation performance” was adopted to describe the navigation off-nominal situation in the subsequent C&N working group discussions and in this paper.

### III. C&N Contingency Management Requirements Practice in the TCL4 Demonstration

#### A. Description of the TCL4 Demonstration

In the Fall of 2018, NASA provided a Statement of Work to six of the FAA-designated UAS test sites to conduct TCL4 demonstration in a series of flights. The six Test Site Operators (TSO) submitted proposals, and Nevada<sup>5</sup> (NV) and Texas<sup>6</sup> (TX) were selected. The demonstration was a set of scenario-driven activities that integrated NASA and the RTT objectives. Five scenarios were created where each scenario focused on different challenges associated with operations in a potential TCL4 environment, such as persistent, mixed tempo, and high-density BVLOS operations over an urban area. The summary of the scenarios is as follows.

- Scenario 1: Normal high-density operations interrupted by a weather event
- Scenario 2: Pop-up concert in a park, emergency operations, and temporary airspace restriction
- Scenario 3: UAS operation near airport, mixed operation with manned aircraft, rogue UAS
- Scenario 4: Flight over people, safe landing, UAS obstacle collision, and response
- Scenario 5: High-density operations, USS negotiation, USS failure

Throughout the early months of 2019, NASA personnel, the TSOs, and their partners conducted collaborative table-top exercises and simulations to prepare for the demonstration. NV prepared the flight range in the downtown Reno area and TX in the downtown Corpus Christy area. The TSOs periodically informed NASA about the status of the certificate of waiver application to the FAA (e.g., use of visual observer), arrangement for accessing city properties, sUAS readiness for operating in the range, and other tasks.

The demonstration took place in the Summer of 2019, and a total of 144 live operations were flown from June 18th to June 28th in the Reno range for scenarios 1, 2, and 4 with nine UA made by three manufacturers, AirRobot GmbH & Co. KG (1), Drone America (5), and SZ DJI Technology Co., Ltd (3). Five USS developed by AirMap Inc., AiRXOS (a GE venture), ANRA Technologies, Avision Inc., and Uber Technologies Inc. supported the operations. A total of 208 operations were flown from August 12th to August 16th, and August 19th to August 23rd in the Corpus Christy range for all five scenarios with nine UA made by two manufacturers, 3DR (2) and SZ DJI Technology Co., Ltd (7). Seven USS developed by AirMap Inc., AiRXOS (a GE venture), ANRA Technologies, Avision Inc., Collins Aerospace (a unit of United Technologies Corp.), OneSky (Analytical Graphics, Inc.), and Uber Technologies Inc. supported the operations.

For all operations, NASA USS connected with other USS for data collection and operations monitoring. In both flight ranges, arrangements were made to only allow demonstration participants in the sUAS operations area. Extended VLOS operations were used to emulate BVLOS operations. That is, UA was in sight of designated visual observers when the operator was unable to see it due to obstruction (e.g., UA behind a building) or distance, and the observers and the operator maintained a line of communication among them to keep track of operational issues. Additional information about the demonstration, including details of scenarios, events, and measures of performance, is in reference [19].

<sup>5</sup> Operated by Nevada Institute for Autonomous Systems (NIAS).

<sup>6</sup> Operated by the Lone Star UAS Center of Excellence & Innovation (LSUASC).

## **B. C&N Contingency Management Requirements Practice in the Demonstration**

### **OSM.001 & OSM.003: Loss of C2 Communications Detection and Mitigation**

During the TCL4 demonstration, operators used sUAS's built-in functions to handle the loss of C2 communications. All sUAS were equipped with a C2 communications system connecting UA and a ground control system (GCS), such as a radio modem and Long-Term-Evolution (LTE) data modem. The GCS was typically programmed to send a heartbeat packet to UA and receive an acknowledgment from the UA continuously, and a prolonged interruption to this exchange, such as five seconds (set by the operator), automatically triggered the UA to return to the launch location (RTL) where the operator was co-located. As the UA approached the launch location, the operator attempted to re-establish the C2 communications to control the UA. Some UA were equipped with a radio transceiver for connecting UA and a hand-held remote controller. In this case, the operator took control of the UA using the remote controller as the UA completed RTL. Some UA were capable of visually indicating loss of C2 communications, such as the fast flashing of status indicator lights on the UA in yellow color. The operator also had an option to proactively command the UA to execute RTL via the GCS when weakening communications link health was known, such as lower than expected signal strength. Given this, OSM.001 and 003 were practiced in the demonstration.

### **OSM.005 & OSM.007: Degraded Navigation Performance Detection and Mitigation**

Degraded navigation performance was handled using sUAS built-in functions. Typically, UA were programmed to automatically land when a certain condition was met, such as lower than six GPS satellites in view (set by the operator). In some cases, UA were programmed to enter a loitering mode using an onboard barometer or downward & forward vision systems (i.e., hold altitude but may drift due to wind) when a certain condition was met and wait for the operator to control the UA. Some UA were capable of visually indicating degraded navigation performance, such as the slow flashing of status indicator lights on the UA in yellow color. The operator had an option to command the UA to land via GCS when navigation performance degradation was known, such as increasing geometric dilution of precision (GDOP) that is an indication of increasing position error. Given this, OSM.005 and 007 were practiced in the demonstration.

### **OSM.002 & OSM.006: Informing USS of Off-nominal Situation Detection Means**

The means to detect C&N off-nominal situations were documented by the TSOs per NASA's request. However, it was unclear whether this information was made available to USS participants; therefore, OSM.002 and 006 were considered not practiced in the demonstration. Recommendation to standardize C&N off-nominal situation detection and use of the standard to better fulfill the requirements is discussed in Section IV.

### **OSM.004 & OSM.008: Informing USS of Off-nominal Situation Mitigation Steps**

In UTM, an operator submits an operation plan to USS and the plan can be activated when the USS accepts the plan after checking constraints, such as conflicts with existing operations and other operation plans [18]. For the TCL4 demonstration, the Data Exchange and Information Architecture and the C&N working groups provided guidance to the participating sUAS operators and USS developers about expanding the operation plan to include a set of contingency plans. A contingency plan was designed to contain a reason for the plan, such as a lost C2 communications link, a mitigation step, such as UA to perform RTL, an area defined in a polygon with vertices in latitude and longitude when the mitigation step involves a destination (e.g., a safe area to land), and planned altitude when the mitigation step involves loitering.

Operators were required to prepare a set of contingency plans so that different types of off-nominal situations can be addressed using the set, and USS developers worked with operators so that a contingency plan can be activated in a timely manner when an off-nominal situation occurs. Analysis of contingency plan activation messages, specified in USSREQ-API [18], showed that of 116 off-nominal situations, only 33 activated a contingency plan while resolving the situation. The number of off-nominal situations was based on all off-nominal reports submitted to USS in the demonstration. Given this, OSM.004 and 008 were practiced in a limited scope in the demonstration. A recommendation to automate C&N contingency management to better fulfill the requirements is discussed in Section IV.

### **OSM.009: Off-nominal data collection**

To support meeting the C&N working group objectives, scripted C&N off-nominal events representing the loss of C2 communication and degraded navigation performance, were included in the demonstration scenarios. sUAS operators participating in such events were directed to act as if their operation encountered the scripted off-nominal

situation and resolve the situation. The occurrence of actual (i.e., non-scripted) off-nominal situations was anticipated and the operators were directed to prioritize safe resolution of the situation over scenario participation. When either scripted or actual off-nominal situations occurred, operators were required to submit an off-nominal report including a narrative of the situation to USS upon resolution of the situation. A total of 116 reports were submitted. Given this, OSM.009 was practiced in the demonstration. An analysis of the submitted reports is in reference [20].

#### IV. Improving C&N Contingency Management Requirements Fulfillment with Automation

##### A. Standardized Means to Detect C&N Off-nominal Situations

In the TCL4 demonstration, the TSO assigned a director of flight operations and allotted staff to oversee operations at the flight range. When a communications or navigation off-nominal situation occurred, the operator contacted the director to inform about the situation (e.g., “Communications to UA is lost”). Once the nature of the situation was understood, the director communicated with USS so that the USS was aware of the change in the operation. If the operator and USS shared a standard means to detect off-nominal situations, such coordination can be automated. This automation would remove the critical path, the director in the center of coordination, and increase operational efficiency as USS would be able to activate a relevant contingency plan without waiting to be informed by the operator. The standard means can also meet OSM.002 and OSM.006.

##### Loss of C2 Communications, UA to Operator Direction

To standardize the means to detect loss of C2 communications, the operator and USS are recommended to agree on the value of two communications performance parameters, the Minimum Data Transfer Rate, and the Maximum Round Trip Latency. To determine the Minimum Data Transfer Rate, a set of telemetry variables that is essential to monitor UA operation (Flight Essential Telemetry, FET) should be adopted, and the data rate necessary to securely transfer FET should be estimated. Table 2 shows the suggested FET variables and associated descriptions. In the table, the camel case is used for the variable name and the unit for the variable is appended. When the operator receives FET and its integrity is confirmed, an acknowledgment should be sent to UA. It is also recommended that the operator transfer FET to USS as received. To determine the Maximum Round Trip Latency, the operator and USS should assess the operational risk that can result from the lack of FET update. For a reference, NASA’s USS specification uses a 1-second update rate for position sharing among USS [18].

Once the values for the Minimum Data Transfer Rate and the Maximum Round Trip Latency are known, the operator and USS can detect loss of C2 communications when the Minimum Data Transfer Rate is not maintained for longer than the Maximum Round Trip Latency. Correspondingly, sUAS should be configured so that 1) UA will automatically begin loss of C2 communication mitigation step when it does not receive FET acknowledgment from the operator for a duration longer than the Maximum Round Trip Latency, 2) UA will resume operation when the communication is reestablished, and 3) UA will initiate safe landing when the loss continues for longer than a Telemetry Timeout period. The timeout is used to instill predictability in handling off-nominal situations. That is, sUAS and the operator can attempt to regain normalcy upon the off-nominal situation, but within the timeout. For a reference, 30 seconds is used for the Telemetry Timeout in the TCL4 demonstration. Discussion on safe landing is in reference [21~24].

**Table 2. Example Flight Essential Telemetry Variables and Descriptions**

Telemetry Variable Name	Description
vehiclePositionLat_deg	Vehicle position in latitude, in decimal degrees
vehiclePositionLon_deg	Vehicle position in longitude, in decimal degrees
vehicleWGS84Alt_ft	Vehicle WGS-84 altitude
pressureAltitude_ft	Pressure altitude in feet
externalTemperature_C	The external temperature in degrees Centigrade
relativeHumidity_pct	Relative humidity in percent
navigationAccuracyCategoryPosition	NACp category from RTCA DO-260B
navigationIntegrityCategory	NIC category from RTCA DO-260B

geometricVerticalAccuracyCategory	GVA from RTCA DO-260B
heading_deg	Heading (deg, True North)
groundCourse_deg	Ground Course, also known as track (deg, True North)
groundSpeed_ftPerSec	Ground Speed in ft/s
trueAirspeed_ftPerSec	True airspeed in ft/s
verticalSpeef_ftPerMinute	Vertical speed in feet per minute, negative indicates descent
roll_deg	Roll (deg). Negative roll indicates left
pitch_deg	Pitch (deg). Negative pitch indicates nose down
yaw_deg	Yaw (deg). Zero-degree yaw is North.
rollRate_degPerSec	Roll Rate (deg/s). Negative indicates the leftward rate
pitchRate_degPerSec	Pitch Rate (deg/s). Negative indicates the downward rate
yawRate_degPerSec	Yaw Rate (deg/s) Negative indicates the counter-clockwise rate
vehicleHealth	Must indicate the state of the communications system, the navigation system, safe landing system when equipped, Attitude Determination and Control system (ADAC), and resource (e.g., remaining fuel/ flight time)

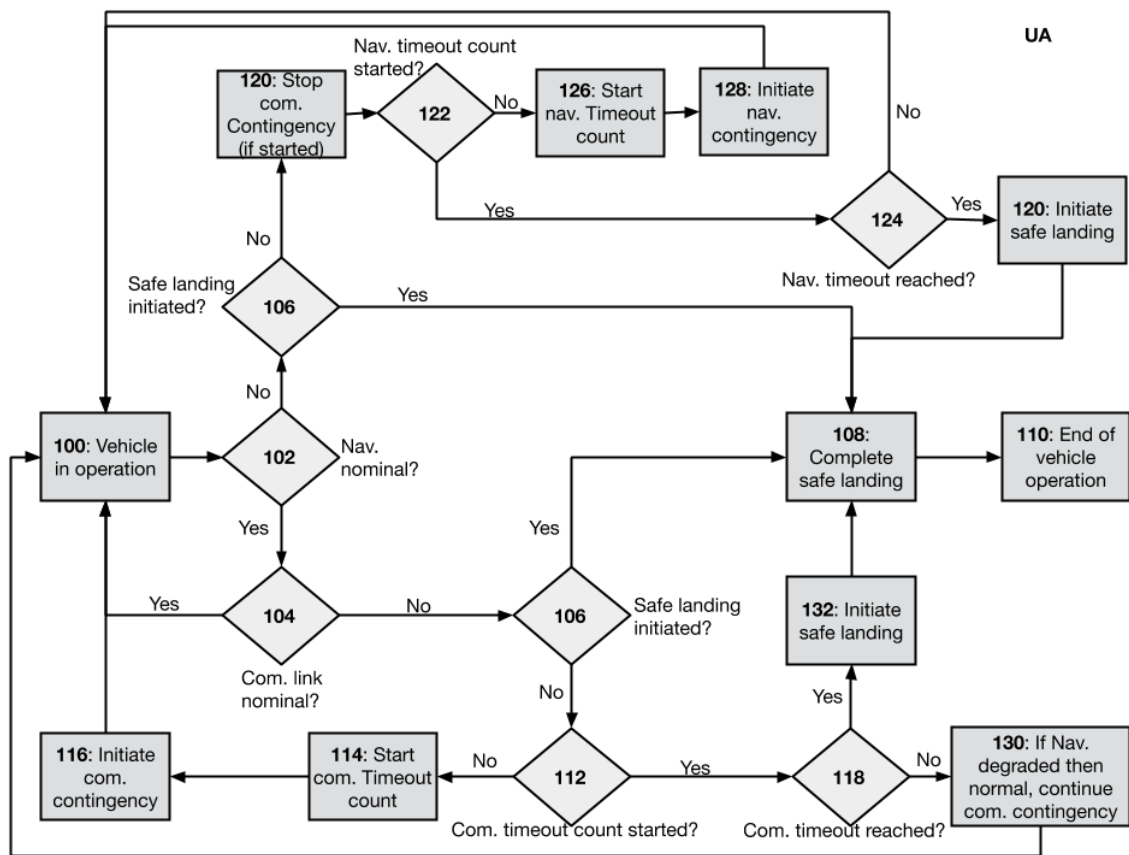

**Fig. 4 UA C&N Off-nominal Situation Mitigation Flowchart**



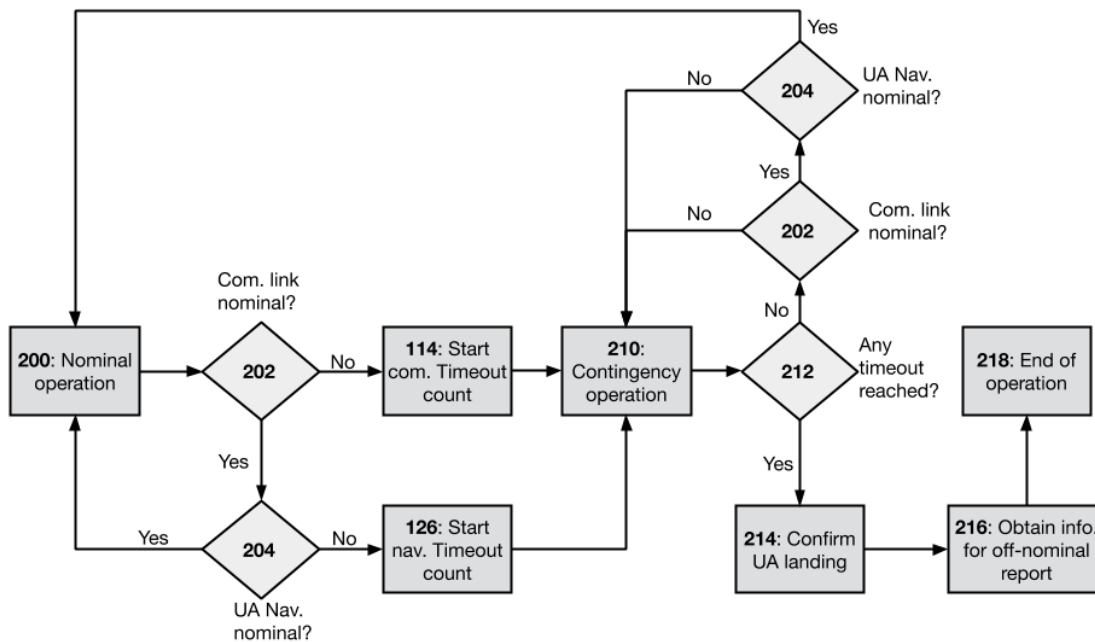

**Fig. 5 USS C&N Off-nominal Situation Mitigation Flowchart**

### Loss of C2 Communications, Operator to UA direction

The operator and USS are recommended to agree on the Response Time to positively confirm that UA can respond to changes in operational constraints, such as the UAS Volume Reservation. For this confirmation, USS should periodically send a constraint change status message to the operator, who then should send associated C2 input to UA for responding to the change. This message can be empty and the associated C2 input null, such as “no constraint change” and “null C2 input”, respectively. For each constraint change status message, USS should receive UA’s acknowledgment conveyed by the operator. When this acknowledgment is not received for longer than the Response Time, a loss of C2 communications situation is detected by the operator and the USS. Correspondingly, sUAS should be configured so that 1) UA will automatically begin loss of C2 communication mitigation steps when it does not receive a C2 input for a duration longer than the Response Time, 2) UA will resume operation when the communication is reestablished, and 3) UA will initiate safe landing when the loss continues for longer than a C2 Timeout period. For a reference, 300 seconds is used for the C2 Timeout in the TCL4 demonstration.

### Degraded Navigation Performance

The operator and USS are recommended to agree on the minimum horizontal accuracy bound (NACp), containment radius (NIC), and geometric vertical accuracy (GVA) necessary for operation [25,26]. While it is possible to use NACp, NIC, GVA categories and values from RTCA DO-260B [27], the use of more granular ones is recommended. For example, GVA in the RTCA document has only three categories (0,1,2) and values (larger than 150m, at or more precise than 150m, and at or more precise than 45m) and additional categories and values would be useful for increasing the number of vertically stacked operations, leading to more efficient use of low-altitude airspace.

Once the minimum NACp, NIC, and GVA for operation are known, sUAS should be configured so that 1) UA will automatically begin degraded navigation performance mitigation steps when NACp, NIC, or GVA becomes worse than the minimum 2) UA will resume operation when the navigation performance meets or exceeds the minimum, and 3) UA will initiate safe landing when the degradation continues for longer than a Navigation Timeout period. For a reference, 10 seconds is used for the Navigation Timeout in the TCL4 Demonstration. The operator and USS can

detect degraded navigation performance with normally functioning C2 communications, and what should be done in case of concurrent loss of C2 communication is recommended in the next subsection.

## B. Integrated sUAS-USS C&N Off-nominal Mitigation

With the standard means to detect C&N off-nominal situations, the sUAS operator and USS are recommended to implement an integrated approach to process mitigation steps. This implementation should fully automate C&N off-nominal situations contingency management and improve the fulfillment of OSM.004 and OSM.008. C&N off-nominal situation mitigation flowcharts for UA and USS are shown in Fig. 4 and Fig. 5. In UA, mitigation of degraded navigation performance is prioritized with the assumption that loss of C2 communications mitigation relies on a nominally functioning navigation system. Boxes 120 and 130 are used to handle this prioritization. For USS, degraded navigation performance can only be detected with nominally functioning C2 communication. Therefore, in box 210, the contingency plan should include mitigation steps for a possible degraded navigation performance when the loss of C2 communication is detected. Additional information on the function boxes and decision diamonds in Fig. 4. and Fig. 5 is in Appendix B.

## V. Conclusion

NASA has been pioneering research and development of technologies and requirements for the traffic management ecosystem for UA that complements the FAA's Air Traffic Management system under the UTM project. Since nominally functioning C&N systems are essential for safe UA operations, NASA, the FAA, industry, and academia developed nine requirements for managing C&N off-nominal situations. This paper described how the requirements were derived and ultimately tested in a field demonstration in 2019. Some of the requirements could not be fulfilled in the demonstration and the paper recommends automating the management of C&N contingency to improve the fulfillment of requirements. The recommendations include the standardization of the means to detect C&N off-nominal situations and the integration of the UAS and UAS Service Supplier off-nominal mitigation process.

## Appendix A

The following questions were sent out to the C&N working group members in January 2017. Twenty organizations provided input: ANRA Technologies, AT&T, DCS, Ericsson, Flyspan Systems, GE, Harris, Higher Ground, Innovets, Intel, InterDigital, Ligado Network, Nokia Bell Labs, R3E, Rockwell Collins, Sharper Shape, Team GC2IT and FRA, T-Mobiles, uAvionix, and University of Colorado, Boulder.

### Communications (command and control, or C2):

- How would one define C2 Quality of service (QOS)?
- What should we measure at aircraft and at Ground Control System (GCS) to monitor QOS during small UAS BVLOS operation?
  - o Ones that are currently measured by UAS operators with standard
  - o Ones that are currently measured but without standard
  - o Ones that should be measured
- Would it be possible to provide QOS forecast for a planned mission area and time?
- What should we measure to do this forecasting?
- How should we define C2 off-nominal situation and what mitigation steps should Unmanned Aircraft (UA) and its operator take?

### Navigation

- How would one define navigation performance?
- What should we measure at aircraft to monitor this performance?
  - o Ones that are currently measured by UAS operators with standard
  - o Ones that are currently measured but without standard
  - o Ones that should be measured
- Can we predict changes in Navigation performance/error for a planned mission area and time?
- What should we measure to do this prediction?
- How should we define navigation off-nominal situation and what mitigation steps should UA and its operator take?

## Appendix B

Explanations of the function boxes and decision diamonds in Fig. 4 and Fig. 5 are as follows.

### Fig. 4

- 100: UA in nominal or contingency mode of operation
- 102: Degraded navigation performance check
- 104: Loss of C2 communications check
- 106: Safe landing in progress check
- 108: Complete the safe landing process
- 110: UA operation completed
- 112: Communications timeout counter initiation check
- 114: Start the communications timeout counter
- 116: Initiate loss of C2 communications mitigation steps
- 118: Communications timeout check
- 120: If loss of C2 communications mitigation is in progress, stop that mitigation
- 122: Navigation timeout counter initiation check
- 124: Navigation timeout check
- 126: Start the navigation timeout counter
- 128: Initiate degraded navigation performance mitigation steps
- 130: If loss of C2 communications mitigation was stopped due to degraded navigation performance situation, and the navigation performance returned, continue the stopped loss of C2 communications mitigation
- 132: Initiate a safe landing process

### Fig. 5

- 200: Nominal operation (i.e., original operation plan active)
- 202: Loss of C2 communication check
- 204: Degraded navigation performance check
- 210: Contingency operation (i.e., contingency plan active)
- 212: Communications or Navigation timeout check
- 214: Confirm UA landing
- 216: Compile information for an off-nominal report filing
- 218: sUAS Operation completed

## Acknowledgments

F. A. Authors thank UTM project, the NV and the TX test site personnel for their dedication, leading to a safe and successful completion of the TCL4 demonstration.

## References

- [1] U.S. Code of Federal Regulation Title 14 Part 107 - Small Unmanned Aircraft Systems, June 2016.
- [2] U.S. Notice of Proposed Rulemaking, "Operation of Small Unmanned Aircraft Systems Over People", FAA, February 2019.
- [3] FAA UAS Traffic Management, URL: [https://www.faa.gov/uas/research\\_development/traffic\\_management/](https://www.faa.gov/uas/research_development/traffic_management/) [retrieved 29 October 2019].
- [4] U.S. Public Law 114-190, "FAA Extension, Safety, and Security Act of 2016", 2016.
- [5] Kopaderkar, P. et. al. "UAS Traffic Management Concept of Operations", AIAA Paper 2016-3292, June 2016.
- [6] "UAS Traffic Management Concept of Operations v1.0", FAA, May 2018.
- [7] Rios, J. L., Mulfinger, D., Homola, J., and Venkatesan, P., "NASA UTM National Campaign", doi: 10.1109/DASC.2016.7778080, September 2016.
- [8] Johnson, M. et. al. "Flight Test Evaluation of UTM Concept for Multiple Beyond-Visual-Line-of-Sight Operations", 12th USA/Europe ATM R&D Seminar, Seattle, WA, June 2017.
- [9] Homola, J. et. al. "Technical Capability Level 2 UAS Traffic Management Flight Demonstration: Description and Analysis", doi: 10.1109/DASC.2017.8101994, September 2017.
- [10] Aweiss, A. et. al. "Flight Demonstration of UTM at Technical Capability Level 3", IEEE/AIAA 38th Digital Avionics Systems Conference, San Diego, CA, September 2019.
- [11] Jung, J. et. al. "Initial Approach to Collect Small UAS Off-nominal Operational Situations Data", AIAA Paper 2018-3030, June 2018.
- [12] Glaab, L. J., and Logan, M. J., "Failure Mode Effects Analysis and Flight Testing for Small Unmanned Aerial Systems", AIAA Paper 2017-3270, June 2017.

- [13] "UAS Traffic Management (UTM) Research Transition Team (RTT) Plan", NASA, FAA, March 2017.
- [14] "Command and Control (C2) Data Link White Paper", RTCA WP-2, March 2014.
- [15] Jung, J., Nag, S., and Modi, H., "Effectiveness of Redundant Communications Systems in Maintaining Operational Control of Small Unmanned Aircraft", IEEE/AIAA 38th Digital Avionics Systems Conference, San Diego, CA, September 2019.
- [16] Enge, P. et. al. "Measurement of Man-Made Spectrum Noise Floor", NASA CR-2004-213551, November 2004.
- [17] Musa, S. M., and Wu, Z., "Aeronautical Telecommunications Network", CRC Press, August 2015, Chap. 6.
- [18] Rios, J. L. et. al. "UAS Service Supplier Specification", NASA TM-2019-220376, October 2019.
- [19] "Flight demonstration of UTM at Technical Capability Level 4", (to be published)
- [20] Jung, J. et. al. "Small UAS Off-nominal Operations Reporting System UTM TCL4 Implementation, Data Collection, and Analysis", (to be published)
- [21] Glaab, L. J. et. al. "Safe2Ditch Autonomous Crash Management System for Small Unmanned Aerial Systems: Concept Definition and Flight Test Results", NASA TM-2018-220110, November 2018.
- [22] Ippolito C. A. et. al. "An Autonomy Architecture for High-Density Operations of Small UAS in Low-Altitude Urban Environments", AIAA Paper 2019-0689, January 2019.
- [23] Di Donato, P. F. A., and Atkins, E., "Evaluating Risk to People and Property for Aircraft Emergency Landing Planning", AIAA Journal of Aerospace Information Systems, Vol. 14, No. 5, May 2017, pp. 259, 278. doi: 10.2514/1.I010513
- [24] Chakrabarty, A., Stepanyan V., Krishnakumar K., and Ippolito, C., "Real-Time Path Planning for Multi-copters Flying in UTM-TCL4", AIAA Paper 2019-0958, January 2019.
- [25] Jung, J. et. al. "Applying Required Navigation Performance Concept for Traffic Management of Small UAS", 30th Congress of the International Council of the Aeronautical Sciences, Daejeon, Korea, September 2016.
- [26] Cho, J., and Yoon, Y., "How to Assess the Capacity of Urban Airspace: A Topological Approach using Keep-in and Keep-out Geofence", Transportation Research Part C 92, 2018, pp. 137, 149. doi: 10.1016/j.trc.2018.05.001.
- [27] "Minimum Operational Performance Standards (MOPS) for 1090 MHz Extended Squitter Automatic Dependent Surveillance - Broadcast (ADS-B) and Traffic Information Services - Broadcast (TIS-B)", RTCA DO-260B, December 2011.