

AEROSPACE SAFETY ADVISORY PANEL

ANNUAL REPORT

TO THE

NASA ADMINISTRATOR

JANUARY 1983

1982 ACTIVITY REPORT
NASA AEROSPACE SAFETY ADVISORY PANEL

	Page
<u>INTRODUCTION AND SUMMARY</u>	1
<u>FLIGHT SYSTEMS EXPERIENCE THROUGH 1982</u>	7
Flight Control and Performance	7
Structural Integrity	10
Orbiter Landing Gear	15
Lithium Batteries	17
EVA and Prebreathing	17
Main Engines	18
<u>IMPROVEMENTS FOR ROUTINE OPERATIONS</u>	22
<u>POLICY ISSUES FOR OPERATIONS</u>	29
<u>FLIGHT SAFETY FOR AIRCRAFT OPERATIONS</u>	35
<u>PLANS FOR ASAP 1983 EFFORTS</u>	38
<u>APPENDIX I - LISTING OF PANEL ACTIVITIES FOR CY 1982</u>	40
<u>APPENDIX II - MEMBERSHIP LIST OF ASAP</u>	45
<u>APPENDIX III - STABILITY OF SPACE SHUTTLE EXTERNAL</u> <u>LIGHTWEIGHT TANK (LWT)</u>	50
<u>APPENDIX IV - MAIN ENGINE</u>	60
<u>APPENDIX V - NOTES ON RELATIONSHIPS OF SHUTTLE PROGRAM TO</u> <u>COMMERICAL AIRLINE LOGISTICS</u>	82
<u>APPENDIX VI - ORBITER ESCAPE CONCEPT</u>	93
<u>APPENDIX VII - NASA AIRCRAFT OPERATIONS</u>	97

AEROSPACE SAFETY ADVISORY PANEL

ANNUAL REPORT

ERRATA AND UPDATE SHEET

<u>Page</u>	<u>Corrigenda and/or Update</u>
12	Last paragraph, 3rd line from top: Change "test-proven" to " <u>test derived.</u> "
13	First paragraph, 3rd line from top: "safety" should be " <u>safely.</u> "
13	Second paragraph, 2nd line from the bottom: "STS-5" should be " <u>STS.</u> "
16	Second paragraph, 5th line from top: remove the word " <u>tire</u> " so that it reads "...severe loads induced..."
18	Second paragraph, 2nd line from top: "emergences" should be " <u>emergencies.</u> "
36	Item 5 at bottom of page: Should read " <u>Experiences in flying large delta-wing or swing-wing type aircraft as well as the SR-71, B-1 and others.</u> "
83	First paragraph, 4th line from top: "exacerbatd" should be " <u>exacerbated.</u> "
84	First paragraph, 4th line from top: "B-757" should be " <u>B-747.</u> "
88	First paragraph, 3rd line from top: "not" should be " <u>no.</u> "
88	Last paragraph, 9 lines from bottom: "Clearly will not save" should be " <u>It is probably unlikely to save...</u> "
89	Second paragraph, 5th line from top: "Faciliteis" should be " <u>facilities.</u> "
89	Second paragraph, 7th line from top: "every" should be " <u>ever.</u> "
89	Last paragraph, 8th line from bottom: "an" should be " <u>and.</u> "
92	Item 2: "Reveiw" should be " <u>Review.</u> " Item 4: "Knopt" should be " <u>Knopf.</u> "

INTRODUCTION AND SUMMARY

The activities of the Aerospace Safety Advisory Panel (ASAP) accelerated in 1982 to support the increased flight rate of the Space Transportation System (STS) and the assessment of data being acquired on the actual flight experience with the various subsystems. Approximately forty meetings took place involving NASA personnel, NASA contractors and members of the ASAP. The meetings included visits to all NASA centers directly involved in the flight hardware and its launching and testing, as well as contractor facilities. Appendix I contains a list of visits for 1982 along with subjects covered during both the individual visits and the complete Panel discussions.

During the year the Panel membership was augmented by the appointment of Gerald W. Elverum, Jr., Vice President and General Manager of the Applied Technology Division of the TRW Space and Technology Group. The purpose of this appointment was to augment the Panel's knowledge of propulsion systems needed because of Dr. Seymour C. Himmel's completion of his six-year term and the signal importance of these systems to Shuttle and payload safety. Because of Dr. Himmel's familiarity with the entire Shuttle development, he has been retained as a consultant.

In addition to Gerald Elverum's appointment, the Panel has added Robert D. Rothi, Chief Design Engineer of the Douglas Aircraft Company as a consultant to follow the progress of essential STS systems, landing gear, flight controls, power and other auxiliary systems as flight experience is obtained. It is the plan to appoint Robert Rothi to the ASAP as a member when a position becomes available in the statutory number of members due to normal completion of terms. The total membership of the Panel is listed in Appendix II.

This year's Panel report will be based upon newly analyzed information from flights STS-1, and STS-2 in 1981, and the more current information from STS-3, -4, and -5. In addition, we have reviewed the status of R&D aircraft and administrative aircraft flight safety procedures and administration for support, test, and training flights utilizing NASA's fleet of aircraft based at the several centers.

The Panel continued with its study of NASA's plans and improvements to increase the flight rate of the Shuttle, improve the logistics and reduce the turn-around costs.

NASA staff activities supporting the needs of the ASAP, the gathering of data, the scheduling of fact-finding for the members and the alert reporting of changes, test results, organization changes, and NASA schedules have been exceptionally well handled during 1982, and the Panel appreciates this excellent support.

As a result of its work the Panel has the following conclusions and recommendations to make:

CONCLUSION 1

The Shuttle has been successful as a developmental vehicle but the flight test series has been too short to completely explore the design performance envelope.

RECOMMENDATION 1

A formal program should be implemented to identify flight test objectives compatible with each Shuttle mission flown so that the entire flight envelope will be defined in a timely manner.

CONCLUSION 2

The determination of the performance envelope of the Shuttle includes a determination of the loads that the vehicle experiences in flight. Before this determination is complete, there have been parallel efforts to reduce actual factors of safety in order to reduce weight. This reduction must proceed cautiously until the structural loads and capability are confirmed.

RECOMMENDATION 2

The Panel recommends that extreme caution be used in decreasing structural factors of safety for weight purposes before all the pertinent flight variations are explored and all relevant data has been analyzed and taken into account. A corollary recommendation is that the Modular Auxiliary Data System (MADS) instrumentation package be carried until the flight limits are determined.

CONCLUSION 3

The Shuttle and its operation is not an airline, even though the airline approach to solving problems such as logistics may well apply. The literal application of the detailed solution of airline problems can be misleading when applied to Shuttle situations. Nevertheless, Shuttle "operations" will be sufficiently different from R&D flying to justify a major operational organization which concentrates on the reduction of turn-around time, cost, and operational safety. The R&D community should respond to the operators of the STS on a demand (contract) basis.

RECOMMENDATION 3

The NASA should identify a single, responsible operational logistics organization, properly staffed, that should determine what commercial methodology is useful to the Shuttle and then determine the extent to which those methods are applied to Shuttle problems.

CONCLUSION 4

Shuttle operation will require a major sustaining engineering effort by the present NASA centers and contractors, particularly until the operational capability is defined and implemented. This should not be confused with, or funded as R&D.

RECOMMENDATION 4

In order to control operational economics, the Panel recommends that the sustaining engineering should be the responsibility of, and be budgeted by, the operational organization, regardless of where and who does the work.

CONCLUSION 5

The pressure of schedules seems to have relaxed the rigor of the certification process as applied to changes.

RECOMMENDATION 5

In the past, the certification of the Shuttle involved many test considerations and reviews. The current and future changes in the Shuttle must have the same rigor of certification. The policy and standards should be established by an independent organization within NASA, e.g, the Chief Engineer, and should

have the direct sponsorship of the Administrator. FAA processes and practices may provide a model. Such a program if it is a function of the NASA chief engineer, would also be independent of any future operations organization and, thus, it would be in a position to certify operational procedure and practices. Such a procedure would also simplify the Panel's problem of being informed of changes in a timely manner.

CONCLUSION 6

The aerodynamic flight stability of the Shuttle is exceedingly important in the landing phases. To the extent that this maneuver is a combination of the ship's very critical stability characteristics, the pilot's perception of control needs, and the computer's logic, it is a deceptively simple thing with little room for error. The apparent panacea of switching to the present autoland system should be cautiously explored. It is also important to give the pilot every tool available to enhance his perception of the craft's performance. The heads-up display is in this category and is useful both in the manual as well as in monitoring autoland performance.

RECOMMENDATION 6

The Panel recommends that autoland be tried at the earliest opportunity where there is a "repeat" pilot who has previously made a manual Shuttle landing. This dual experience will be invaluable in assessing manual vs. automatic operation. It is also recommended that the total installation of the heads-up display be expedited and be operational for this demonstration.

CONCLUSION 7

Substantial redesign of the SSME turbomachinery is required for the desired engine life at the outputs needed by proposed future payloads.

RECOMMENDATION 7

The Panel recommends the design of new replacement turbomachinery for the SSME that will achieve current required mission life at the full power level. If possible without compromising the achievement of these objectives provisions might be incorporated for future growth. In addition to the procurement of adequate numbers of the current turbomachinery elements, the interim need for spares created by the short life of the current machines at high output must be met.

CONCLUSION 8

The Panel feels that the landing gear tires and brakes have proven to be marginal and constitute a possible hazard to the Shuttle.

RECOMMENDATION 8

A study of a gear redesign should be started that will achieve an adequate factor of safety with the maximum proposed Shuttle loads. It seems to the Panel that such an effort should include an investigation of changing the attitude of the Orbiter on its gear. Reducing the nose-down attitude would substantially reduce wheel loads during rollout and braking.

FLIGHT SYSTEMS EXPERIENCE THROUGH 1982

The ASAP, in following the results of current flight data commend both the development teams at the centers and the operational teams which launched, conducted the mission and retrieved the Orbiter and its crews. The ASAP particularly tracked the performance of the internal power systems, control systems, and the thermal protection systems, all of which had concerned the Panel in the initial development phases of the program. It is encouraging to report that all of these systems appear to be performing well.

The Panel has continuing concern regarding the progress in flight control development, the confirmation of structural integrity, the achievements of operational ratings of the main engines, and the transition of the entire system to operational status in the absence of complete flight confirmation of the Shuttle element performance. These specific areas of concentration for the ASAP are in the following sections.

FLIGHT CONTROL PERFORMANCE

The Demonstration of Autoland Systems

The Aerospace Safety Advisory Panel recommends that NASA Headquarters assure the completion of the remaining simulations and tests of the Orbiter Autoland system, including touchdown and rollouts, and, if successful, encourage the earliest use thereof.

We believe that safety will be enhanced if the approach and landing conditions of airspeed, angle of attack, sink speed, and touchdown point can be optimized by automatic control. The experience that suggest this emphasis includes:

- a. Studies of Shuttle landings to date show that tire,

wheel, and brake stresses are approaching limits.

b. Short runways, with inadequate overruns, are a cause for concern, for instance, a transAtlantic abort to Dakar.

c. Landing with excess speed increases stresses, as well as exposing the Orbiter to a "weight on wheels" instability that is divergent, as in most delta-wing aircraft.

Problems in pitch control of the Orbiter have been observed since the Pilot Induced Oscillations (PIO) of the fifth Approach and Landing Test (ALT 5). Some improvements can be made in software and mechanical controls, but correction of the basic characteristics would require complete redesign; perhaps including canard control surfaces.

A skilled pilot, under non-stressful conditions, can "grease" the Orbiter onto the runway; witness some of the beautiful landings to date. This requires great precision in establishing approach conditions, and the avoidance of any sudden inputs to pitch control. Aborts, heavy payload landings, less skilled pilots - all bias conditions toward the limits in control and mechanical capability.

An autoland landing takes the uncertain "gain" of the pilot out of the loop. The precision and resolution of the Inertial Measuring Units and the integrating rate gyros combined with Microwave Scanning Beam Landing System (MSBLS) and the digital autopilot allows the main computers to control attitude, airspeed, and sink rate to a precision that few humans can match except under ideal conditions.

As to reliability:

a. Automatic landings have been in use in commercial aircraft operations for about 10 years.

b. Elements of the autoland system have been used on every Shuttle flight excluding final glide slopes and landing.

c. Dozens of Shuttle training aircraft flights have used the MSBLS at KSC (down to about 20 feet above the runway).

In attempting to promote demonstration of the autoland system, the ASAP recognizes these factors as valid:

a. Astronauts, by virtue of years of training and simulation experience in the manual control process, are understandably reluctant to "let a machine do it."

b. Monitoring progress of the autoland system is difficult without a heads-up display or other device to assist in judging progress and eases take-over in the event of system failure.

Nevertheless, the ASAP urges such a demonstration and suggests the following:

1. A demonstration of the autoland system should be scheduled for a repeat commander or pilot as soon as the heads-up display is useable.

2. NASA should reexamine the auto braking and autoland gear extension systems to make the autoland system complete.

3. Provisions for autoland should be installed at the most likely contingency landing sites, e.g. Dakar.

4. The investigations of ground control de-orbit should be revisited for possible rescue via automatic de-orbit and remote or automatic control to autoland.

STRUCTURAL INTEGRITY

During the year 1982, the ASAP has given particular attention to the safety aspect of the following structural areas:

- o Lightweight external tank
- o Use of instrumented flight data
- o Continued expansion of structural operating limits
- o Structural modification of OV-102
- o Filament wound motor cases for solid rocket boosters

Filament Wound Case for Solid Rocket Boosters

The ASAP reviewed the structural aspects of the Filament Wound Case (FWC) at MSFC on June 10. The Panel's impression based on this limited review is that the plans for design, development, and testing are well thought out and that the structural integrity of the final product will be solidly based on test data. The minimum flight design factor of safety (F.S.) is 1.4. At the pinned joints between composite and steel, a F.S.-2.0 is used with "A" allowables* based on test data.

Light Weight External Tank (LWT)

The specification for the original external tank, now called Heavy Weight or Standard Tank (HWT), stated that the total inert weight be not greater than 77,902 pounds. The actual inert weight of the production HWT is 75,900 pounds, of which 57,195 pounds is structure.

*"A" allowables refers to material properties (e.g., tensile and compressive strength) equal to 99% or more of the population of measured values with a confidence level of 95%.

As a weight reduction measure, the external tank has now been redesigned and the new light weight tank has an actual inert weight of 66,800 pounds, of which 52,589 pounds is structure; so in going from the heavy to the light the structural weight was reduced by 4,600 pounds or 8.0 percent. The remainder of the 10,400 pounds, sometime reported as weight reduction from the original specification, took place in such nonstructural items as plumbing, thermal protection provisions, and updating the weight bookkeeping to account for the fact that the production HWT was 2,000 pounds underweight. Panel interest was focused on the structural integrity of the LWT.

In its review of the LWT the ASAP has centered its attention on the liquid hydrogen (LH₂) section for the following reasons (further discussion is found in Appendix III):

- o The structural weight of the LH₂ tank of the LWT was reduced by 10.5 percent from that of the HWT.
- o A critical design condition for the external tank is at staging of the Solid Rocket Boosters (SRB). In the absence of the SRB thrust, most of the 1.5M pounds total thrust of the Orbiter's three main engines is transmitted from the Orbiter to the aft end of the LH₂ tank and passes upward through the LH₂ tank to the liquid oxygen (LOX) tank, which is the major mass of the stack at that time. The thrust loading produces an axial compression and an overall bending due to the eccentricity of the thrustload, both of which produce compressive stresses in the LH₂ tank shell facing the Orbiter. The most probable failure mode is an instability, or buckling, of the LH₂ tank shell which could lead to serious consequences.
- o The buckling strength of the LH₂ section of the LWT has been verified by test only to limit load (i.e., 109% of rated power level of the main engines) so that any margin

of safety between actual operating conditions and failing conditions is dependent solely on analytical procedures.

- o Analytical procedures for prediction of shell instabilities are complex and not well correlated with experimental results, particularly for concentrated loads imposed on a complex nonuniform stiffened shell such as the LH₂ tank.
- o The analyses that had been done were linear bifurcation types (STAGS and BOSOR).

The ASAP was concerned about the structural integrity of the Light Weight External Tank because:

- o Data on strength justification has been sparse.
- o Reluctance to depend entirely on linear analytical methods to predict failing instability of a complex shell-like structure subjected to concentrated loads as in the LH₂ tank when the design factor of safety is as low as 1.265.

The maximum thrust of the main Orbiter engines to be used during STS-6 is 104% of rated power level. This provides a test-proven F.S. of 1.14 (i.e., 1.19 FS @ RPL/1.04 RPL) for this flight. Concern within ASAP over this narrow margin resulted in a meeting which is reported in Appendix III among NASA personnel, technical members of the Martin-Marietta Corporation, with ASAP members at which views concerning the adequacy of analysis were expressed by two independent consultants in analytical methods for shell structures. The following recommendation resulted from this meeting: The ASAP accepts the adequacy of the current analysis and tests for the next Shuttle operation, but recommends that the nonlinear analysis now planned be performed to add further confirmation of the structural adequacy of the Light Weight Tank (LWT) before flights using 109% of rated power level are approved. We understand this work is now underway.

Use of Instrumented Flight Data

The first five Shuttle flights have produced a substantial amount of instrumented flight measurements that are of extreme importance to safety exploiting the full structural capability of the STS. To realize the latent benefits of these flight data, it needs to be reduced to a readily useable form and then analyzed by stress analysts familiar with the structural arrangement, the design loading conditions, the analytical and experimental internal load determinations, and the failing stress allowables.

Continued Expansion of Structural Operating Limits

The instrumented flight data already collected during the missions of STS-1 through STS-5, properly analyzed, will provide a valuable data base to aid in predicting the safe magnitude of steps that can be taken in exploring beyond the boundaries established by the first five flights. The Development Flight Instrumentation (DFI) package used on the first five flights had the capacity to measure and record information from 4,000 sensors (strain gauges, thermocouples, pressure transducers, etc.). Because the DFI occupied a good portion of the payload bay and weighed about 11,000 pounds, it had to be removed from OV-102 after STS-5 to make room and payload available for Spacelab 1. There are no plans to use the DFI package on any future STS missions. To safely explore and establish the structural limits needed to utilize the full capability of the STS-5, some flight instrumentation to monitor critical strength items will be required.

Some of the issues involved in expanding the structural limits are:

- o Ascent and entry loads
- o Payload/Orbiter dynamic interaction
- o Ascent aerodynamic loads distribution
- o Structural thermal stresses versus cross range

It appears that the vehicle best suited to carry the brunt of the structural limits expansion is OV-102 after it has been through the Maxi-Mod process and has been equipped with a Modular Auxiliary Data System (MADS).^{1/} Thus modified and equipped, OV-102 will have full strength and adequate instrumentation to safely expand the structural operating envelope.

Structural Modification of OV-102

OV-102, as it flew the STS-1 through STS-5 missions, had unexpected structural limitations brought about by weight growth and early loads later found in need of correction. Discrepancies were dispositioned for the operational flight tests (OFT) and performance placards were issued on maneuver load factor (2g) and landing sink rate (6 fps). In addition, top sun conditioning was required prior to entry to relieve thermal stresses.

The ASAP understands that present plans are to use OV-102 to fly the STS-9 mission. The landing gross weight for STS-9 will be about 222,000 pounds which compares to the maximum previous landing weight of 209,483 pounds (STS-4). Also, the

^{1/}The MADS planned for OV-102 will have the capability to record data from 855 sensors, of which about 500 are allocated to structures-related measurements.

load carried as cargo will be somewhat over 35,000 pounds which exceeds the previous maximum of 32,279 pounds (STS-5). Therefore, the STS-9 flight will need to be made with more restrictive flight limits than STS-1 through STS-5 in order to maintain the same margins of safety. In order to maintain the margin of safety of 1.4 in an abort-once-around, the maneuvering load factor, n_z , would be restricted to 1.4g and the sink rate on landing would be restricted to about 4.5 fps. The Panel believes that, with special training and special precautions, the tighter restrictions required for STS-9 can be safely flown, albeit at some higher level of risk than with a full strength vehicle.

The ASAP recommends that serious consideration be given to incorporating the Maxi-Mod modification into OV-102 following the STS-9 mission and also installing the planned data system (MADS), so that a full strength vehicle with adequate instrumentation can be used to continue the expansion of the operating envelope to the safe limits of the fleet vehicle.

ORBITER LANDING GEAR

The landing gear including wheels, tires, and brakes, is vital for the safe completion of any mission. With the future flights going to higher weights and lower margins, possibly even negative margins, it is imperative that existing capabilities be fully explored, documented and improved where necessary.

Of particular concern are the following:

- o The inclusion of HUD or Autoland to consistently minimize the touchdown speed and distance from the runway threshold and to assure the optimum vehicle attitude to preclude PIO's and high ground loads.

- o The inclusion of an Autobrake system to relieve the work

load on the pilot during a high strain period and to assure a uniform maximum brake pressure available to achieve the desired stopping distance.

- o The high torque peaking of the carbon lining and the low strength of the beryllium stator and rotor keyways. The combination of materials should be reviewed as well as the means of attaching the brake to the axle. Excessive axle deflections under the abnormally severe tire loads induced by the negative angle of attack at high ground speeds dictate some type of floating mount to prevent the brakes from carrying ground loads in addition to the normal braking loads.

- o The abnormally severe loads imposed on the main tires due to the 3.92° negative angle of attack with the nose tire on the ground at high speeds. At 240,000 pounds with aft c.g., the static load on each main tire is only 54,000 pounds; whereas, at 165 knots the tire load increases to 140,000 pounds. Not only does this require stronger tires, but also higher inflation pressures, over 315 psi, to keep the tire deflections and carcass temperatures within limits. As tire pressures and ground speeds increase, the attainable coefficient of friction between the tire and the runway decreases thus increasing the stopping distance. A longer nose gear would help reduce the negative angle of attack and the main gear loads. Or it might even be possible to replace the dual main wheels with four wheel bogies to reduce the load per tire.

- o The foreign-object damage to the thermally protected Shuttle surface by debris thrown up by the tires was mentioned in last year's report. When the landing performance has been improved to the point of using the paved runways, this issue will be resolved. Being able to use the paved runways available for normal landing and for emergency aborts is essential for continuing safe operations.

LITHIUM BATTERIES

The Panel was asked to assess the safety of the use of lithium-bromine complex batteries just prior to the launch of STS-5. The batteries in question were small A-A size cells for use in hand-held radios; D size cells in the cassette data recorders, space suit lights, TV cameras and the survival radio. An investigation revealed that the internal cell and battery hazards were acceptable and the Panel agreed that no changes should be made prior to STS-5, since the batteries were already on hand if not on board.

Lithium batteries have a large advantage in energy storage capability over standard batteries but their characteristics in many operational modes are not fully understood and accidents may occur if operating limits are exceeded and quality assurance is not assiduously controlled in their manufacture. Protection is provided to control the hazards. However, there are undoubtedly certain applications that are not practical with any other battery. In those cases, they should be used with suitable precautions. It is not so clear why the hazard would be acceptable in a flashlight or hand-held radio application. In making such a judgment, one should weigh all the factors such as energy requirements, safety, convenience of handling, operating limitations and disposal.

A corollary of this particular Panel activity is that a mechanism must be developed to bring hazardous items such as this to the Panel's attention in a timely manner.

EVA AND PREBREATHING

Extra-vehicular activity is a useful adjunct to the Shuttle's capability but, as currently planned, it is not without important limitations. To be most useful the suit should operate

at the environmental conditions sufficiently close to those of the cabin to eliminate the need for prebreathing in order to prevent the "bends." Current prebreathing time and protocol limits the emergency capability of EVA. The ASAP recognizes that the design of an all-purpose space suit, useful as a work station as well as an emergency device, is not simple but believes that the present design should be reviewed to make sure that it is acceptable.

It is not clear to the ASAP that there are major requirements for EVA except in some emergencies or the replacement of failed elements of expensive satellites. The requirements for emergency use appear to the ASAP to preclude systems that require long hours at different pressures than the normal cabin pressure and extended prebreathing times. It is suggested that an analysis be made for different failure scenarios. Different EVA requirements will undoubtedly emerge and such requirements could dictate EVA equipment design requirements.

MAIN ENGINES

With but one exception, all propulsion systems of the Shuttle functioned flawlessly during all the flights this year. The performance of each of the systems: the main engines (SSME's), the solid rocket boosters (SRB's) and the orbital maneuvering system (OMS) engines was within the range predicted. The one incident that marred this otherwise perfect record was the failure of the SRB recovery system in the STS-4 flight. This failure had no effect on the mission itself although the SRB motor cases were lost. The subtle cause of this failure was identified and the corrective action implemented for the STS-5 flight succeeded in overcoming the problem.

The certification program for the FPL (109%) version of the SSME, in contrast, has been beset by test failures and problems

that have impeded achievement of engine certification. There were two serious incidents, both resulting in significant loss of hardware. Both of these failures involved developmental hardware changes, in one instance installed on a certification engine. Failure reviews were conducted, the causes identified and corrective actions implemented. The loss of hardware suffered exacerbated an already existing problem of limited engine hardware availability. The Panel has noted in the past its concern about the meager supply of hardware in the SSME program.

The problems that were encountered with SSME turbomachinery during development and certification of the RPL (100%) version of the engine have reappeared in the FPL program. This is most probably a consequence of the higher speeds and operating temperatures associated with operating at the FPL thrust level. These problems include turbine blade cracking and sheet metal cracking in the HPFTP and bearing wear and distress and subsynchronous-whirl in the HPOTP. All of these phenomena are life-limiting. As a consequence, during the FPL certification program frequent replacements of the turbopumps have been required. As of the end of October 1982, no FPL high-pressure turbopump had been able to accumulate more than 2500 seconds of operation without removal for cause.

There exists a program of design changes to the turbopumps intended to alleviate the problems encountered. It is the consensus of the several groups that have examined the situation that, with continuing development and the present approach to certification, an engine with satisfactory and safe performance at 109% should be achieved albeit with limited life. This will require frequent change-outs and inspections of the turbomachinery operationally.

There is a growing body of opinion that the origin of the problems of the turbomachines is of a "systems" nature rather than a set of discrete component difficulties. Under such

conditions a set of "fixes" to components within the physical constraints of the current design would, at best, be of limited value.

It would seem prudent, therefore, to undertake a major redesign of the turbopumps as the long-range solution to the problems. At the same time, in recognition of the planned rapid increase in launch rate and the long time (3-5 years) required to design, develop and certify redesigned turbomachinery, provision should be made to acquire additional spare turbopumps of current FPL design to accommodate the frequency of removals that is to be anticipated.

During 1982 the Panel also emphasized the SSME operational planning and status of logistics planning so that the inevitable emphasis on turn-around time reduction and turn-around costs will not introduce additional hazards. It was apparent to the Panel that substantial planning had been done but that the budget support of such plans may be a major constraint towards the attainment of safe rapid turn-around. Specifically:

- o The critical dependence on the performance of the high and low pressure turbo pumps for both oxygen and hydrogen, coupled with only modest improvements in the mean-time-to-failure of these elements, suggests that more spares are essential. This would contribute to safety and would preclude dependence on cannibalizing production elements for flight support.

- o Not apparent in the planning is the development of a dedicated facility or function for maintenance and overhaul turn-round of main engines. This will be necessary before minimum safe turn-around time and cost is achieved.

- o Proposals within NASA which include contractor operation of major elements of the Shuttle or the entire STS for purposes of reducing cost should be carefully evaluated for their effect

on safety. This is noted in the discussion of the SSME because it is felt that operation, testing, inspection, and monitoring of flight data is still, and will be for some time, critically dependent on experience rather than on developed methods and procedures. Shifting turn-around or maintenance responsibilities to a separate organization should be approached with extreme caution.

o The decision to purchase another Shuttle is not a substitute for a fully developed logistics, maintenance, and spares program, which is properly funded. This comment applies to the entire STS program.

Appendix IV contains a more detail report on the above summary comments with particular reference to the investigations done in logistics and spares planning.

IMPROVEMENTS FOR ROUTINE OPERATIONS

NASA ORGANIZATION ARRANGEMENTS

The challenge of achieving true operational status for the space transportation system is, in many ways, as rigorous a test of NASA's management and technical capabilities as the development effort itself. Recognition of this fact at NASA's top management levels is essential if the management challenge is to be met successfully.

The problem arises, in part, by the Shuttle's progressive testing and performance enhancement which will continue well into the operational flight schedule. This means that the experience and expertise of the development centers and their associated contractors must be readily accessible during this shakedown period that will last for another 5 years or longer. At the same time, however, an effort to build a truly operational system within an organizational structure dominated by the development centers is likely to fail. This is the core of NASA's present management dilemma.

The development centers--particularly JSC and MSFC--are not attuned by experience or philosophy to the management discipline that is essential to a successful commercial operation. Their understandable mutual competition within NASA for assignments and budgets, and their associated reluctance to let go of areas of responsibility once assigned, are serious obstacles to building a well-integrated and disciplined operational entity. In other words, the decentralization and fragmentation of responsibility inherent in a center-based strategy will, in the end, confound all efforts to operate the system efficiently through steering committees and task groups. At the same time, NASA cannot risk cutting itself loose from the centers' experience and expertise.

The Panel also recognizes the severe budgetary constraints that are likely to impede realization of an optimum logistics strategy in support of a routine and reliable commercial operation. For example, it would be unrealistic to maintain the level of spares that would routinely be obtained by a commercial airline operation. Similarly, a dedicated overhaul facility in the vicinity of KSC may also be an unrealistic expenditure, much as it might improve turn-around time. Numerous and difficult trade-offs will be needed in this budgetary environment. This fact heightens the need for a clearly defined line of responsibility and authority within NASA to make these decisions.

It is not the Panel's responsibility to prescribe a specific solution to this management dilemma surrounding the Shuttle's transition to an operational commercial system. However, the significant safety considerations that are directly linked to this transition suggest several approaches or principles that should be considered by NASA management.

- o The organizational arrangement within NASA that is to be responsible for commercial operation of the Shuttle should be determined and announced, even though full implementation of this arrangement might not be feasible for the next several years.

- o As a first step, the management core of this operational organization should be established as soon as possible and given authority to resolve major management and budget issues that will inevitably arise among the development centers as they support Shuttle testing and enhancement during the transition period. This core group would logically be situated at NASA Headquarters. This is another way of saying that someone at or near the top must clearly be in charge to control the natural competition among the centers.

- o The relationship of the development centers to the operational organization should be one of subcontractors,

providing the development skills and expertise as requested on a reimbursable basis. Budget and Shuttle performance improvement program decisions would be the province of the operational organization.

o The role of the Shuttle Processing Contractor must be recognized as evolutionary, given the Shuttle's continuing enhancement and a host of other uncertainties. The operational organization within NASA must retain ultimate responsibility for the Shuttle's commercial operation, as well as defining the specific roles and responsibilities of the SPC. A similar Headquarters control of the roles and responsibilities of the potential payload processing contractor should exist.

o NASA should give serious consideration in the long term to establishing the operational organization as a Government corporation, in order to achieve effective separation from the development centers which otherwise might function as de facto commercial operators of the STS. The benefits of establishing such an entity whose sole reason-for-being was the efficient and reliable operation of the Shuttle could be significant. At the same time, such a separation might enable the centers to pursue their historic R&D roles more effectively.

TRACKING AND DATA ACQUISITION

Today the Spaceflight Tracking and Data Network (STDN) consisting of fifteen ground stations provides less than 20% coverage of the Shuttle in orbit. The transmission of both voice and commands on the FM uplink from the ground to the Shuttle and the transmission of voice and telemetry on the FM downlink are provided by an S-band communications system operating at the relatively low data rate of 32 KBPS uplink and 92 KBPS downlink. There are four flush mounted antennas on the Orbiter vehicle which provide a dual redundant communications path to the ground stations.

In the near future the STDN will be augmented by two operational Tracking and Data Relay Satellites in geosynchronous orbit and separated by approximately 135 degrees and will be able to extend this coverage of the orbiting Shuttle to 85 - 90%. These satellites - also called WESTAR - together with a ground station at White Sands, New Mexico, constitute the Tracking and Data Relay Satellite Systems (TDRSS). The system will provide NASA with telecommunication services as needed. Current plans include orbiting a spare satellite between the two active satellites that can be moved into position to replace a failed satellite. The Shuttle Orbiter S-band system will then be able to communicate with the ground through the TDRSS system and will do so whenever it can.

In addition, a wide-band communications link from the Shuttle Orbiter to the ground via the TDRSS system is currently planned. This link will be used for on-orbit transmission of 2 MBPS to 50 MBPS of scientific data and, on a time-shared basis, will also accommodate television, analog scientific data, experiment or operational tape recorder dumps, etc. A deployable 36 inch steerable antenna shared with the Orbiter rendezvous radar subsystem, operating in the Ku band and stowed in the payload bay will be used for this communications link. Unfortunately, this Ku band system is only single-string for budgetary considerations but on the surface at least does not appear to be a safety related item.

When the TDRSS is proven to be operational, all but three or four of the STDN ground stations will be phased out. The target date is mid-1984. Although the direct communication ground link will then be far less than the current 20% coverage, the DOD ground facilities at seven locations world-wide will always be available as a backup should the satellite relay system fail. (It should be noted that this will not be the first time that a manned spacecraft has utilized satellites for communication - it was successfully demonstrated during the ASTP joint mission with

the Russians in the mid-seventies.)

No plans are currently underway by NASA to assess specifically the safety aspects of the new communications system and the ASAP has not yet been briefed on the subject. However, the Panel will request such a briefing sometime during the calendar year 1983. Scheduled tests of the system are planned for March and again in August of 1983 and the Panel will certainly wish to review those test results.

SURVIVAL CONCEPTS

Over the last few years the ASAP has participated in many discussions of crew survivability, particularly during the launch and possible ditching of the Shuttle as the result of an abort. Although the circumstance of a ditching is remote, the conclusion of analysts suggests that an intact structure from which escape is possible on ditching is not probable. Thus, an ejection system operable at lower speeds is perhaps the only practical solution to the ditching problem. It should also be configured to serve for some launch aborts. The standard ejection seats have already been determined to be impractical for more than two crew members but there is a current technology in use involving a tractor rocket that lifts a person through a suitable opening. Concepts show that after ejection of four crew members, the succeeding flight crew members move into position at the cabin opening before firing their rockets. This solution is very complex, but the Panel recommends that NASA study its application to the Shuttle with two to six crewmen and determine the cost to install in a new Shuttle as well as the cost and feasibility of retrofitting current Orbiters.

The Panel feels that an even more likely problem is a ground incident occasioned by a blown tire or gear failure on landing. Immediate ejection could not only save a major number of the crew, but would open more escape routes. This should be analyzed

in detail because a landing incident is believed to be more likely than the ditching or a major launch malfunction.

ROLE OF CREW VS. GROUND

The real time control and management of space missions by Mission Control has served well but requires extensive and expensive communications if continuous control is, in effect, to be maintained. This was necessary during the test mission of the STS and desirable where Shuttle missions are unique and relevant experts can be gathered at Mission Control. In the case of the Shuttle as a transport system, substantial economies would result if a greater degree of reliance on the crew were to be achieved. The crews must be permitted and aided to develop a reliance on their own capabilities in emergencies that may occur. It is suggested that crews should be encouraged to work toward the routine execution of the entire mission, calling upon ground assistance only in unusual situations. The ultimate savings will only be realized if the entire operational support structure is streamlined as a result of flight experience and appropriate divisions of responsibility are achieved.

ASAP PRIORITY LIST OF SAFETY IMPROVEMENTS

Over the years a number of suggestions have been made by the ASAP not to emphasize major hazards in the current design of the Shuttle systems but to note those systems which do not appear to be sufficiently simple or to have adequate safety back up and must, therefore, demand "every flight" detail checks and inspections before safety can be assured. The ASAP feels that NASA has not done a comprehensive study of this type of systems improvement but has concentrated primarily on improvements to the payload performance. As in prior reports and letters to NASA, the ASAP suggests such a review of the consistency of redundancy in the Shuttle systems designs and the potential for changing entire systems concepts to simplify operations by permitting

quick turn-arounds without "every flight" attention to the potential safety performance of the subsystem.

Without such a study it is not possible to defend any particular priority listing but the ASAP, on the basis of its collective judgment continues to feel concern about the following systems:

- o The APU system - particularly the APU installation in the solid propellant boosters.
- o The rudder-speed-brake mechanical control system downstream of the drive motors.
- o The landing gear system, particularly the wheels and tires (can the ground attitude of the Orbiter be modified?).
- o Crew escape (for maximum number) at launch and prior to potential ditching or during and after a landing accident.
- o EVA system to reduce time from decision to emergence.

POLICY ISSUES FOR OPERATIONS

Whatever NASA decides to do with respect to organizational structure to support routine operations of the Space Transportation System, it appears to the ASAP that Headquarters attention should be directed to the creation or clarification of broad NASA policy in several critical areas. These include: logistics and maintenance planning, certification, configuration control, and component life determination. A brief discussion under each of these headings follows:

LOGISTICS AND MAINTENANCE PLANNING

A comprehensive overall integrated logistics plan for the entire Shuttle system is essential and overdue. This should include all major elements; e.g., Orbiter, ET, SRB, SSME, OMS & RCS, etc. Overhaul and repair facilities as well as spares stocking and warehousing issues should also be addressed. The plan should address the "near term" problems specifically and give an outline of the "longer term" requirements. Even if this plan is altered shortly after issue, the discipline entailed in its preparation will have served its purpose.

A maintenance plan for the entire system should be evolved along the lines of the FAA Maintenance Review Board philosophy. This can be either a part of the plan in the preceding paragraph or alternatively developed as a separate task. It will be required, however, to examine the adequacy of the present spares procurement quantities.

The Maintenance Engineering Analysis (MEA) or Failure Modes and Effects Analyses (FMEA) process for all components of the Orbiter is admirably thorough but may be exhaustive and, therefore, completed too late to be of value for the plans mentioned in the two previous paragraphs. While MEA's will be essential for major components, a more practical approach using

flight line and launch pad experience should be considered in the interests of placing spares orders immediately. A small task force could probably accomplish this if given a suitable mandate.

The spares quantities which have been ordered thus far and which were declared in General Abrahamson's logistics status review at KSC on November 9 to be essentially completely delivered in some cases, are probably insufficient. The small task force referred to in the previous paragraph could examine this question, but if the spares of SSME's and their major component are any criterion, then there may be a problem. Certainly in the interest of safety we cannot continue the present practice of "cannibalization" and robbing of the production line to meet each launch date.

The prospect of eliminating or reducing the coverage of certain maintenance manuals, illustrated parts catalogs and wiring diagram manuals in the interest of economy is viewed with dismay. The success of the current concept, especially in the longer term (say 1990), will be partly dependent upon adequate and accurate publication.

The "sustaining engineering" function should be critically examined to avoid duplication between NASA and the Shuttle prime contractors. If it is eventually vested in the SPC group, it should draw skills from each major contractor and take due notice of the problems of continuity of experience which might be endangered by attrition, retirements, and the like. Obsolescence of some of the equipment and disappearance of some smaller vendors will be a special problem in this respect in the "longer term."

In addressing the above, it may be useful to study "Notes on Relationships of Shuttle Program to Commercial Airline Logistics" November 20, 1982, included as appendix V of this report.

THE CERTIFICATION PROCESS

In the process of reviewing changes for performance improvement and the basis for certification, the ASAP is concerned that the certification process for such changes is inconsistent, i.e., the rigor of the originally specified certification process.

Examples of changes that may have had less rigor in their certification are: the safety factor reduction in the new light weight external tank and the decision not to test to ultimate load, the substitution of quilted material for the silicon thermal protection tile over large areas of the Orbiter. Taking such actions during an experimental program is inevitable, but steps should be taken to complete certification of all significant changes.

The suggestion by the ASAP is that NASA Headquarters institute a review of the total certification process for Shuttle hardware as well as support functions such as software certification, ground support processes, maintenance monitoring, etc. It is further suggested that the policy for certification and the approval for deviation be a Headquarters responsibility.

CONFIGURATION CONTROL

The objective of a certification program for a vehicle is to validate that all of its parts in fact perform together as a completely configured system. Substitutions of components or subsystems that have not been involved in such a formal integrated test program could invalidate the certification status of the vehicle by changing its configuration.

Several times during the year the Panel was presented with information regarding configuration identification program related to the initial builds underway for the remaining Orbiter vehicles. However, at some of the subsystem levels the detailed configurations have not always been determined. For example, while investigating the logistics support plans for the SSME, we found that complete indentured parts list does not yet exist for full-power engines. We believe there are many issues still open on the final full-power engine configuration. Lack of a detailed indentured parts list is cause for concern with regard to even defining explicitly the baseline for a configuration control program on the SSME.

Shortly before the STS-5 launch there was even some discussion as to whether all three engines would have the same certified configuration as a result of the impeller damage on the pump of one engine and lack of an available replacement with identical configuration. Although this problem was "resolved" by using the damaged pump, it highlights another issue; namely, how to maintain a certified system configuration without an adequate supply of configured components for replacement.

Because changes are being continually introduced to correct problems identified either during development or from flight operations, it is likely that each of the four Orbiter vehicles

will have different, as-integrated, configurations at the detailed level. This may be true also in the case of the external tank and the solid boosters; at least for the next several years. Furthermore, the extremely limited replacement hardware supply will cause changes to the as-integrated configurations through substitution of new design components or cannibalization of older design components. This is particularly probable on the engine, power supply and electronics subsystems.

It is the Panel's opinion that NASA must adhere to a rigidly disciplined methodology in which each vehicle's configuration is identified and recorded in detail, and its individual certification status maintained. There should be no planned substitution of components without a full understanding of the implications to the overall system operation and safety. The computerized configuration and validation records combined with change control rules should also form the basis for the logistic maintenance and reliability programs. One must particularly guard against changes made under the pressure of an imminent launch schedule where system implications cannot always be identified nor assessed.

An example that amplifies the above concern was raised by the premature separation of the parachute riser lines on the SRB cases during STS-4. In this case, a change in operational concept was coupled with a hardware change. However, it appears that a change in switch sensitivity may have occurred which resulted in the riser line release at the low g-level of the frustum separation event. The important safety implication is that an adequate vehicle Configuration Control Program involves not only the documentation of a fully certified system configuration and a disciplined change authorization procedure, but also quality control at the field level to assure that components changed are as specified.

COMPONENT LIFE DETERMINATION

In the design and development process for the Shuttle system, specifications were set up for each element and then a test program devised to demonstrate that the component would qualify for the desired life under the postulated conditions. Now that the Shuttle is flying, we have the opportunity to check whether or not the real conditions are as predicted and to determine the actual life of the component. This information is not only needed in the spares and logistics program, but will establish what the real margin of safety is for the various subsystem of the Shuttle. These data are vital for the guidance of the sustaining engineering program and must be obtained even though the necessary test and inspection may increase estimated costs and lengthen the turn-around time in the near term.

FLIGHT SAFETY FOR NASA AIRCRAFT OPERATIONS

During 1982 a series of accidents in aircraft operations made it clear that further emphasis on operational safety for support and test aircraft was necessary throughout the NASA organization. The ASAP, responding to a specific request from Administrator James Beggs, issued a letter report on September 13, 1982 (see Appendix VII).

Following the Panel report, NASA Headquarters initiated reviews of JSC and LaRC by ECO System International Company resulting in their report "NASA Flight Operations Review". In the ECO report, as well as the ASAP review, studies of the distribution of accidents as to cause such as weather, pilot error, powerplant, etc., have shown that pilot error is the principal culprit. This is true whether the class of operation is commercial airline, general aviation, or military. There is no reason to believe that NASA flight operations are any different.

Assuming that pilot error will be the principal cause of future NASA accidents, it is clear that the normal management approaches to discipline and procedures must be augmented and monitored.

Pilot errors can be attributed to training, current proficiency, physical condition, and mental attitudes such as carelessness or lack of patience. NASA has special problems because of the variety of its flight operations and the wide spectrum of pilot experience.

Supervision is a necessary, but not sufficient, condition to combat pilot errors. Selection, training, proficiency, and physical conditioning are some of the factors that can be monitored but when the wheels come up into the wells, the pilot is on his own and pilot attitude governs flight safety.

Pilot attitudes are a result experience, training, and by examples set by other pilots of established reputation. In this respect, NASA has a wealth of expertise that can make a major contribution. The ASAP suggests an education program that could be sponsored by the Intercenter Aircraft Operations Group (ICAOG) which could take the form of a series of "leadership" seminars to be given at weekly (or monthly) flight safety meetings held at various centers.

The "stable" of experienced and famous test pilots NASA employs is large. It is felt that a series of seminars on interesting subjects by selected speakers would instill in the younger and less experienced pilots an appreciation of the disciplines and attitudes that make for safe flying and allowed these senior pilots to achieve a remarkably accident free career.

The program could include:

1. The flying characteristics of the B747 and the problems of trucking the Orbiter across the country.
2. LaRC discussing stall and spin avoidance and recovery techniques.
3. The pilots could give a talk on traffic control and communications around and approaching busy airports like JFK, LAX, O'Hare, Atlanta, and Washington National.
4. DFRC might describe some of the special techniques and precautions taken in establishing speed and altitude records.
5. Review experiences in flying large delta-wing aircraft, e.g., SR-71, B-1.

6. Some of the hazards exposed and lessons learned through the NASA Aviation Safety Reporting System could be discussed by an appropriate speaker from Ames Research Center.

NASA response to previous recommendations has been entirely positive although all programs based on these suggestions have not as yet been implemented. The extent to which the centers implement standard, cooperative programs and the progress on utilization of the Intercenter Aircraft Operations Group will be reviewed and monitored by the ASAP in 1983.

PLANS FOR ASAP 1983 EFFORTS

During 1983 the ASAP intends to concentrate on the progress of the space Shuttle flight experience with particular emphasis on the confirmation of the design flight envelope, maximum c.g. limits, maximum landing weight, and maximum reentry heat load. In addition, particular attention will be paid to those systems that should continue to have individual inspection, refurbishment, or flight-to-flight replacement to maintain safety in routine operations.

In addition, the ASAP intend to concentrate on the improvement of systems to enhance performance or reduce cost and to be certain that such changes do not add extra hazards. It is hoped that such changes will be made for the specific purpose of reducing hazards. It is the conviction of the ASAP that changes which reduce specific requirements for flight-to-flight maintenance or part replacement will not only reduce hazards but also cost of operation. 1983 should see the use of the heads-up cockpit display making possible the demonstration of autolandings.

Changes now planned that will require specific attention are the light weight external tank and the filament-wound solid rocket propellant cases. These designs will be followed as they mature. Not yet planned nor defined are changes to reduce the hazard to the crew in a number of potentially survivable incidents such as ditching, launch malfunctions, and hard landings. Elsewhere in this report the ASAP has suggested a serious study of progress if it is initiated.

As operations expand there will be a variety of payloads, many of which may have the potential of increasing the hazards for routine operation. Of particular concern are the payloads which have propulsion and pyrotechnic elements or extend beyond the payload bay door envelope. Of particular interest is the wide-tank Centaur.

A major change in Shuttle communications and geographical communication coverage will take place with the introduction of the TDRSS satellite based communications system. During 1983 the Panel will review the details of this system and the potential it has for hazards or the removal of present hazards to safe operations.

NASA AEROSPACE SAFETY ADVISORY PANELAPPENDIX ILISTING OF PANEL ACTIVITIES FOR CY 1982

Panel fact-finding sessions have been conducted on the average of three times per month for 1982. Members and consultants have during this same period visited six NASA centers and facilities (ARC, DFRC, LaRC, JSC, MSFC, KSC) as well as NASA Headquarters, and three NASA prime contractors. Although these have been focused on the Space Transportation System, there have been a number of fact-finding visits aimed at reviewing and assessing aeronautical operations and attendant flight safety. The Panel has, where practical, participated in a number of significant in-house reviews; e.g., Flight Readiness Reviews, STS Mission Control activities. Panel efforts have been supported by the Panel Staff Director through in-depth and continuous participation and reviewing of STS program/project activities and aeronautical R&D and administrative flight safety activities.

The breadth of Panel discussions goes from the NASA Administrator and Deputy Administrator to Program Directors on into the subsystem design and test personnel (the "hands-on" people). Beyond this is the Panel's annual report provided to the NASA Administrator and through testimony before the appropriate House and Senate subcommittees in January-March period. Where requested, the Panel provides individual support to special review teams such as the Solid Rocket Booster STS-4 Review Group and the Shuttle Main Engine (SSME) Assessment Group.

APPENDIX I

SUBJECT: Panel Fact-Finding Sessions, CY 1982

<u>Date</u>	<u>Location</u>	<u>Attendees/Subject</u>
1/21/82	Headquarters	Annual meeting, 1981 activities (Panel)
2/24/82	Wash., DC	Testimony before Congress (Panel)
2/25-26/82	JSC	Discuss results derived from STS-2 which affect future flight/mission hardware (Panel)
3/9-10/82	KSC	STS-3 Flight Readiness Review (Parmet, McDonald, Hawkins)
3/15/82	Headquarters	Flight test activities, aero safety meeting w/Beggs (Davis)
3/20/82	KSC	L-2 review for STS-3 (Hawkins)
3/21-22/82	JSC	STS-3 mission control room (Davis)
3/28-29/82	JSC	MCC operations, preparation for landing STS-3 (Davis)
4/26-28/82	Rocketdyne	SSME status (Himmel)
5/5-7/82	HQ/MSFC	Met w/codes O & M STS development & operation. ET, SRB, SSME status (Panel)
5/10-11/82	LaRC	Aircraft flight safety (Davis)
5/18-19/82	MSFC	SSME FPL incident (Himmel)

5/26/82	Headquarters	Orbiter capability, assessment, expendable launch vehicle, etc. (Hawkins)
6/10/82	MSFC	Filament wound case for solid rocket motor (Hedrick)
6/11/82	RI/SD	STS structural adequacy (Hedrick)
6/14-16/82	KSC	STS-4 FRR; SPC discussions & briefing (Battin, Parmet, Grier were at SPC & FRR; Davis at FRR)
6/22-23/82	KSC	SSME task force (Himmel)
6/25/82	KSC	FRR (Grier)
6/26/82	KSC	STS-4, L-2 review (Grier)
6/30- 7/4/82	JSC	Mission control room STS-4 (Davis)
7/7-9/82	DFRC/ARC	Aviation Safety (Davis)
7/19/82	Michoud Assembly Facility	Light weight external tank (Hedrick)
8/2-5/82	HQ/MSFC	Chief Engineer's review Panel re SRB failure on STS-4 (Himmel)
8/9-13/82	RI/Palmdale RI/Downey	Logistics, SSME, STS & Orbiter performance Palmdale operations (Panel)
8/9/82	DFRC	HUD, SIMS for STS

		missions (Davis)
8/19-20/82	Ames/DFRC	Discussion on similarities between Orbiter & SR 71 landing. Discussin w/test pilots at DFRC on landing characteristics (Davis)
8/26/82	ARC	Orbiter TPS (Hawkins)
9/13/82	Headquarters	EVA meeting (Hawkins)
9/14-15/82	RI/Downey	STS-5,-6 design certification review teleconference (Grier)
9/16-17/82	JSC	HUD, landing gear, crew egress (Davis, Rothi)
9/28/82	Rocketdyne	SSME logistics & status (Elverum & McDonald)
10/1/82	Headquarters	STS-4 anomolies & STS-5 configuration differences (Parmet)
10/25/82	KSC	STS-5 FRR (Grier, Elverum, Rothi)
10/25-27/82	KSC	SSME Management Overview Board Meeting (Himmel)
11/2/82	RI/Downey	Orbiter; Applicatin of Airline method-logistics and spares (McDonald)
11/3-4/82	C. Draper Lab.	Stability and control of the Orbiter on re-entry and touchdown (Davis)
11/8-11/82	KSC	Management council meeting; STS-5; L-2 review (Panel)
11/22-23/82	KSC	Orbiter structures capabilities (Hawkins,

12/13-14/82

KSC

Hedrick, Cohen)
Technical Readiness
Review for FRF (Roth,
Himmel)

APPENDIX II

Membership List of the AEROSPACE SAFETY ADVISORY PANEL

CHAIRMAN

Mr. Willis M. Hawkins (9/88)*
 Senior Advisor
 Lockheed Corporaton
 P.O. Box 551
 Burbank, CA 91520

MEMBERS

Dr. Richard H. Battin (4/86)
 Associate Department Head
 Charles Stark Draper Lab, Inc.
 555 Technology Square
 Cambridge, MA 02139

Mr. I. Grant Hedrick (11/85)
 Presidential Assistant for
 Corporate Technology
 Grumman Aerospace Corporation
 Bethpage, NY 11714

Lt. Gen. Leighton I. Davis (12/83)
 USAF (Ret.)
 Consultant
 729 Stagecoach Road, Four Hills
 Albuquerque, NM 87123

Mr. John F. McDonald (6/86)
 Former Vice President
 Technicial Service
 TigerAir, Inc.
 3000 North Clybourn Avenue
 Burbank, CA 91505

Mr. Gerard W. Elverum, Jr. (4/88)
 Vice President-General Manager
 Applied Technology Division
 TRW Space and Technology
 Redondo Beach, CA 90278

Mr. Norman R. Parmet (3/88)
 Consultant
 5907 Sunrise Drive
 Fairway, KS 66205

*Appointment terminates (-)

Mr. Herbert E. Grier (1/85)
Consultant
2223 Avenida de la Playa
Suite 304
La Jolla, CA 92037

Mr. John G. Stewart (4/86)
Assistant General Manager
Tennessee Valley Authority
400 Commerce Avenue - E12B18
Knoxville, TN 37902

CONSULTANTS

Dr. Seymour C. Himmel
12700 Lake Avenue
Apartment 1501
Lakewood, OH 44107

Mr. Robert D. Rothi
6 Chuckwagon Road
Rolling Hills, CA 90274

EX-OFFICIO MEMBER

Dr. Stanley I. Weiss
NASA Chief Engineer
NASA Headquarters
Washington. DC

STAFF

Mr. Gilbert L. Roth
Staff Director, Aerospace Safety
Advisory Panel
NASA Headquarters
Washington, DC 20546
A/C 202 755-8381

Ms. Susan Webster
Advisory Committee Assistant
NASA Hdqrs. Code LB-4
Washington, DC 20546
A/C 202 755-8380

APPENDIX IIIBACKGROUND MATERIAL FOR
LIGHT WEIGHT EXTERNAL TANK
ASSESSMENTDiscussion

The shell structure should be able to maintain its structural integrity, i.e., not collapse or rupture, at values of loads up to some safe value (called ultimate load) above the maximum expected operational load (called limit load). The ratio ultimate load/limit load is called factor of safety (F.S.). A factor of safety is used to provide protection against uncertainties in load, material properties, manufacturing variations, etc.

The F.S. in general use for aircraft is 1.5. An F.S. of 1.4 was adopted for general use in design and certification of the STS, and the HWT was designed for an F.S. of 1.4. For the LWT the F.S. was reduced to 1.25 for loads categorized as "steady-state" or "well defined." The original F.S. of 1.4 was retained for loads categorized as "dynamic" or "all other". The composite F.S. equals 1.265 in the critical design condition for LH₂ tank shell buckling.

HWT Static Strength Test - The HWT was static tested in the MSFC vertical test stand in 1979. The critical test areas were submerged in liquid hydrogen so that material strength properties would be the same as in actual operating conditions. The LH₂ section of the HWT was pressurized to 32 psi, which is the lower limit of flight pressurization (the lower limit is critical for shell buckling). The maximum level of Orbiter thrust load applied is uncertain since it is reported as 113.5 percent of limit in one part of the test report and 130 percent in another part of the same report (MMC-ET-TM03-0, Volume III, "External

Tank LH₂ Strength Test Report). The HWT test specimen did not show any signs of distress at the load levels imposed.

LWT Static Test for Buckling - A limit load verification test was run on LWT-2 in the horizontal proof test stand at Martin Marietta's Michoud, Louisiana, plant. Gaseous nitrogen at room temperature was used in the LH₂ section to provide an internal pressure 23 psi greater than ambient. The 23 psi differential pressure was held constant while external loads were applied to produce the "equivalent"1/ of 100 percent design limit axial load in integral skin/stringer shell at the area2/ that was predicted by analysis to be most critical for panel buckling.

1/"Equivalent" is used here to indicate that the design limit load was reduced to account for the reduced modulus of elasticity of the 2219-T87 aluminum material at room temperature compared to the operating temperature of -423oF, i.e., loads are divided by the factor $(12.4 \times 10^6) / (10.8 \times 10^6) = 1.1$

2/"The STAGS-C analysis by Martin Marietta indicated that the minimum margins for compressive buckling occurred at the 10:30 and 1:30 o'clock positions at Station 1702.

This test was carefully run so as not to exceed the local design limit stress. Because the internal pressure, which is stabilizing, was only 23 psi rather than the minimum operational value of 32 psi, it is estimated that the test demonstrated approximately 109% of limit load or 119% (i.e., 1.09×109) at rated power level of the main engines. It provides no margin to cover any variation in load or variation in strength. It is

unlikely that all LWT's will have strengths greater than LWT-2.

LWT Proof (or Acceptance) Test - In addition to the static test for buckling just described, which was performed on LWT-2 only, each production LWT receives a burst proof test as an acceptance test. These acceptance tests are run in the horizontal test stand facility at the Martin Marietta plant at Michoud, Louisiana. The acceptance test is designed to impose the "equivalent"^{1/} of 105 percent of limit load tension on all welds. The internal pressure alone is sufficient to proof load the axial welds, but five different combinations external loads are used in addition to the internal pressure to attain the proper loads on the circumferential welds. This proof test contributes nothing toward the verification of required compressive buckling strength of the LH₂ tank shell.

^{1/}"Equivalent" is used here to indicate that the proof pressure was reduced to account for the reduced toughness of the 2219-T87 aluminum material at room temperature compared to the operating temperature of -423°F, i.e., pressures are divided by the factor 1.1. Since the high side of the flight ullage pressure regulation band is 34 psia and the LH₂ under flight acceleration is 6.4 psi then the proof pressure

$$P(\text{proof}) = (40.4 \times 1.05) / 1.1 = 38.6 \text{ psig}$$

APPENDIX III

STABIITY OF SPACE SHUTTLE EXTERNAL LIGHT WEIGHT TANK (LWT)

David Bushnell and Bo Almroth

December 14, 1982

LMSC-D877306

LOCKHEED PALO ALTO RESEARCH LABORATORY
APPLIED MECHANICS: DEPT. 52-33, BLDG. 255
3251 HANOVER ST., PALO ALTO, CA 94304

STABILITY OF SPACE SHUTTLE EXTERNAL LIGHT WEIGHT TANK (LWT)

David Bushnell and Bo Almroth

ABSTRACT

The next and future launches of the Space Shuttle will include a redesign external (disposable) tank. This tank is of lighter weight than that used to date. It has been tested to design limit load, not to ultimate load. During a certain phase of the launch there are regions of the tank subjected to destabilizing loads generated by the thrust of the Orbiter engines. Recently, the Aerospace Safety Advisory Panel, a committee that advises NASA Headquarters on issues involving the Space Shuttle, expressed concern about the adequacy of the new design with regard to buckling. The committee recommended that experts in the field of shell buckling be called in to evaluate the new design, render an opinion of safety, and make recommendations about possible further analyses and tests. David Bushnell and Bo Almroth were selected by the Panel and by NASA Headquarters to perform these tasks. On December 9th and 10th Bushnell and Almroth visited the Martin Marietta Company, Michoud Division, New Orleans, in order to evaluate the light weight tank design with regard to buckling. On December 11th they, representatives from Martin Marietta, the Aerospace Safety Advisory Panel, and NASA officials met at NASA Headquarters to discuss the buckling issue. As a result of Bushnell's and Almroth's evaluations, it was decided that the light weight tank could be flown on the next Shuttle launch without further analysis, but that nonlinear analyses with the use of the STAGSC-1 computer program should be performed with an eye toward future launches, during which the destabilizing loads are expected to be somewhat higher than those on the next flight.

PARTICIPANTS

NASA HEADQUARTERS, SPACE SHUTTLE OFFICE:

Lt. General James A. Abrahamson, USAF, Rm 468 NASA
Headquarters, Associate Administrator, NASA Office of Space
Flight Responsible for Shuttle

Mike Weeks, Jerry Fitts, Dave Winterhalter, Raoul Lopez

NASA MARSHALL SPACE FLIGHT CENTER:

Jim Kingsbury and others

AEROSPACE SAFETY ADVISORY PANEL:

Willis Hawkins, Chairman of NASA Aerospace Safety Advisory
Panel (213) 847-6623

Grant Hedrick, VP Grumman (516) 565-3506, Member of Aerospace
Safety Advisory Panel

Gilbert Roth, Staff Director, Aerospace Safety Advisory Panel,
NASA Headquarters, Washington, DC 20546 (202) 755-8380

Nathaniel B. Cohen, Stanley Weiss

MARTIN-MARIETTA COMPANY:

MICHLOUD DIVISION, NEW ORLEANS:

Al Norton, VP Engrg., Martin Michoud, New Orleans, (504)
255-3920

Dick Foll, Director Engrg. Martin Michoud, (504) 255-3015

Ben Groninger

Jon Dutton, Mgr. Mechanical Engrg. Martin-Michoud, (504)
255-3666

Dale Karr, Engineer-Analyst, Martin-Michoud, (504) 255-3680

Gale Copeland, Bob Mann

DENVER DIVISION:

Jim Burridge, Senior VP; Al Holston, Jim McCandless

NASA REPRESENTATIVES PRESENT AT MEETINGS AT MARTIN-MICHOUD:

Frank Boardman and Jack Nichols, MSFC/EP42; John White,
MSFC/MAF

LOCKHEED MISSILES AND SPACE CO., PALO ALTO, CA:

David Bushnell, Staff Scientist, Lockheed 52-33/255, Buckling
expert (415) 858-4037

Bo Almroth, Senior Staff Scientist, Lockheed 52-33/255,
Buckling expert (415) 858-4027

BACKGROUND AND PROBLEM DEFINITIONS

On Wednesday, November 24, 1982, Willis Hawkins, in his capacity as chairman of the Aerospace Safety Advisory Panel for NASA's Space Shuttle program, telephoned David Bushnell about a buckling issue in the Space Shuttle external tank. Hawkins asked Bushnell to call Grant Hedrick for details. That afternoon, Bushnell, Almroth, and Hedrick held a telephone conference in which Hedrick defined the issue.

Figure 1 shows the Space Shuttle external tank (ET). At a certain phase of operation following launch, local regions of axial compression develop just forward of longerons by means of which Orbiter thrust loads are transferred to the external tank. In this region the external tank, which contains liquid hydrogen and is internally pressurized to 32 psi, must be designed so that it will not buckle under the combined hoop tension and axial compression. The tank is stiffened internally by stringers with T-shaped cross sections, as shown in Figure 3. (First two rings in the foreground are typical.)

On Space Shuttle flights to date the disposable external tank has had an inert weight of 7100 pounds. This tank, henceforth called "heavy weight tank" (HWT) or "standard weight tank" (SWT), was tested under cryogenic conditions to an ultimate load of 1.40 times design limit load. Because of the need to reduce weight, a new lighter weight disposable tank has been designed, henceforth called "light weight tank" (LWT), with an inert weight of 60500 pounds. About half of the weight saving came from structure; the skin between stringers was reduced in thickness in certain areas, the cross sections of certain rings were reduced, and material was taken out of the aft portion of the large longerons by means of which orbital thrust loads are transferred to the LH₂ tank.

The new light weight tank has been tested to design limit

load in the horizontal proof test stand at Martin Marietta's Michoud, Louisiana, plant. A new definition of ultimate load, 1.25 times design limit load, has been accepted. Buckling analyses conducted at Martin Michoud by Dale Karr indicate that the new tank will withstand the new ultimate load. The new tank will fly on the next launch, now planned for January, and on future Shuttle flights.

Due to the pressures of time and money there is currently no plan to test the new tank to the new ultimate load. This lack of a test on a stability-critical structure designed to a lower margin over design limit and than the previous tested tank worried Hedrick. Accordingly, as a member of the Aerospace Safety Advisory Panel, he advised that an independent evaluation of the analysis methods and the new design with regard to buckling be carried out. Bushnell and Almroth were consulted as experts in this field.

After the telephone conference with Hedrick, Bushnell called Hawkins on November 24 to request that Hawkins officially introduce Bushnell and Almroth to whoever at Martin Michoud has overall responsibility for the structural integrity of the Shuttle external tank. Bushnell and Almroth would then gather enough data from Martin in order to render an opinion.

On Friday, December 3 Gil Roth at NASA Headquarters contacted Bushnell at Lockheed. Roth requested that Bushnell contact Al Norton at Martin Michoud to set up a visit by Bushnell and Almroth on December 9th and 10th at Martin in order to learn details of the geometry and buckling analysis conducted at Martin. Bushnell first called Norton, who directed him to Dick Foll. Foll knew about the proposed visit to Martin by Almroth and Bushnell; he was agreeable to the proposed dates of the visit; and he supplied the name, Jon Dutton, manager of the department responsible for the analysis of the Shuttle external tank. Bushnell called Dutton in order to obtain certain details

of geometry and loading that would permit some analysis to be conducted at Lockheed with PANDA, BOSOR4, and possibly STAGSC-1 before the visit on December 9th and 10th. These details were supplied to Bushnell on Friday afternoon, December 3 by Dale Karr.

Following the telephone contacts at Martin Michoud, Bushnell called Roth at NASA Headquarters to confirm the dates of Almroth and Bushnell's visit to Martin. Roth told Bushnell that there would be a meeting at NASA Headquarters on Saturday, December 11, in General Abrahamson's office to discuss the buckling issue and to learn the opinions of Almroth and Bushnell. This meeting would be attended by General Abrahamson, Gil Roth, Willis Hawkins, Grant Hedrick, Al Norton, Dick Foll, Jon Dutton, Bo Almroth, David Bushnell, people from NASA Marshall Space Flight Center (MSFC), and others.

On Friday, December 3 and Monday and Tuesday, December 6 and 7, Bushnell conducted buckling analyses of the local regions of the Shuttle external tank subjected to compressive stresses. PANDA and BOSOR4 runs were made. Results from these two programs agree with each other for cases in which both apply. A preliminary conclusion, from the data supplied by Dale Karr over the telephone and from PANDA and BOSOR4 calculations based on these data, is that the new, lighter weight Shuttle external tank has sufficient margin with regard to buckling.

ET CONFIGURATION

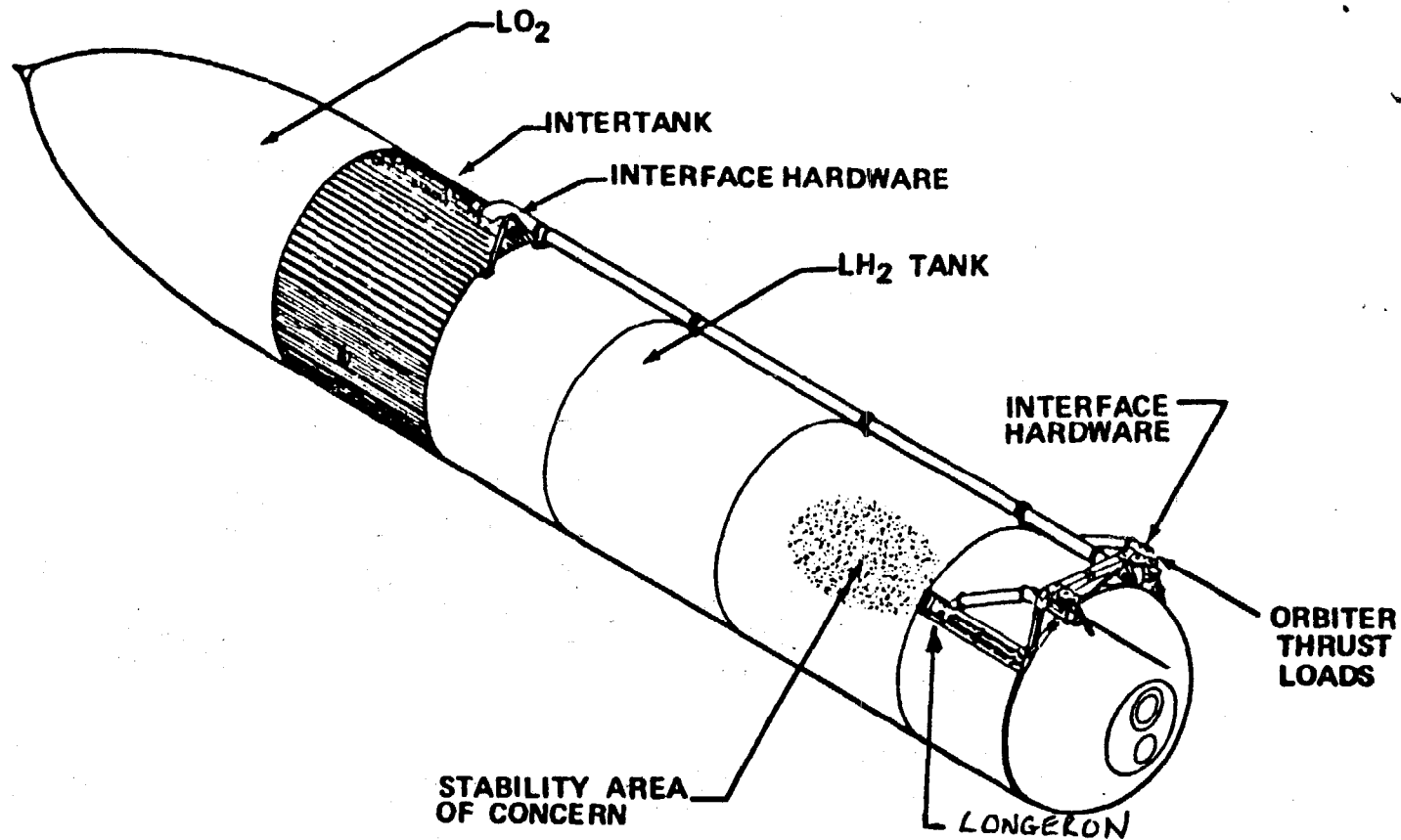
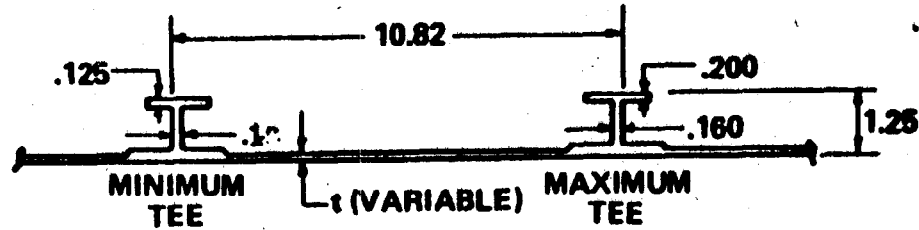

Fig. 1 External tank configuration showing area where buckling is possible

MARTIN MARIETTA
MICHOD DIVISION

LH₂ BARREL - SKIN STRINGER



SKIN THICKNESS RANGE
 $.128 \leq t \leq .320$

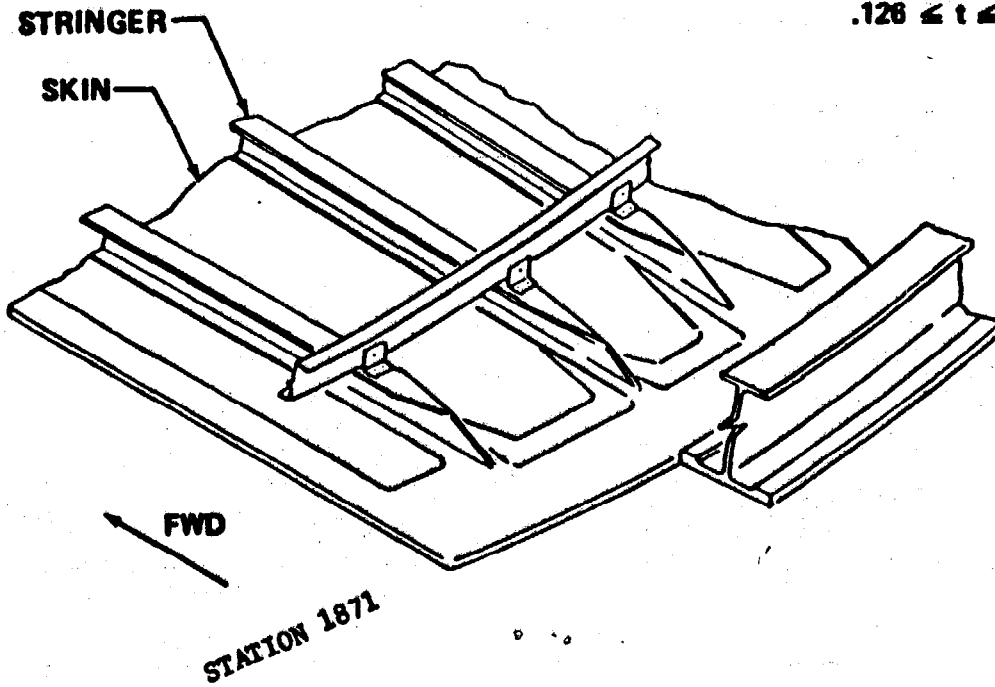

Fig. 2 Panel configuration in buckling-critical region

MARTIN MARIETTA
MICHOD DIVISION

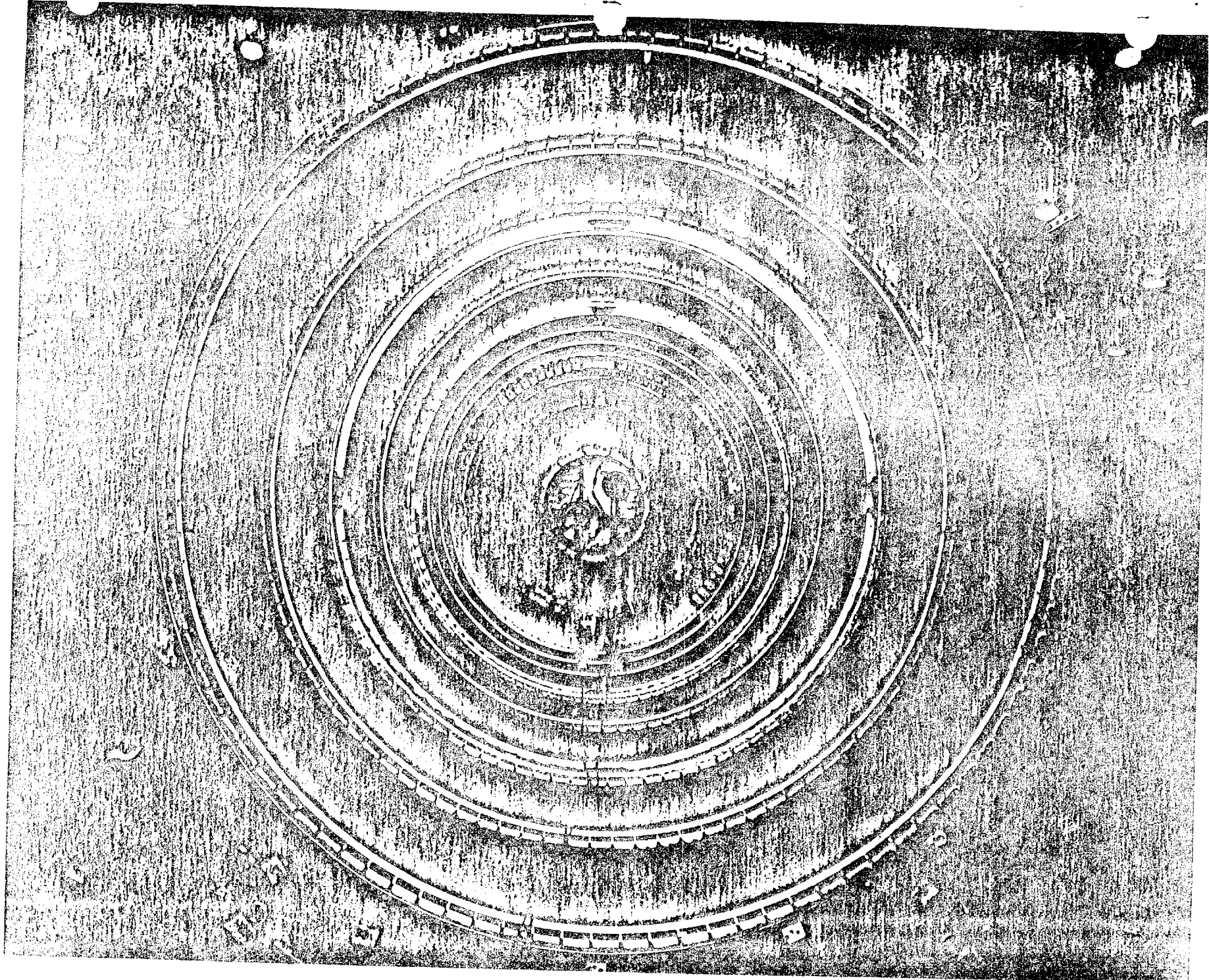

Fig. 3 Liquid Hydrogen Tank Interior (SWT) (Courtesy Martin-Marietta Corp.)

APPENDIX IV
MAIN ENGINE

September 29, 1982

TO: Willis M. Hawkins
FROM: Jerry Elverum and John McDonald
SUBJECT: NASA-ASAP Visit to Rocketdyne to Examine SSME Logistics
and Support, September 28th

As noted in Gil Roth's memo of August 18th (page 2) we visited Rocketdyne, Canoga Park, to review the logistics and support aspects pertinent to the SSME. A detailed presentation was given to us and two copies (BC 82-223) have been sent by Rocketdyne directly to Gil Roth. The program was divided into two main parts:

- (a) turn-around operations and maintenance together with support systems, and
- (b) an outline of the precepts upon which the support activities are being based.

Vince Wheelock (SSME Logistics Manager) presented part "a" and his Chief of Schedule Management, Harvey Colbo, gave part "b". A copy of the Rocketdyne organization chart is attached hereto (attachment 1). Persons also attending are listed in attachment 2.

These notes will include a discursive commentary upon the material presented to us, together with selected charts, and will conclude with some more specific recommendations of a form suitable for adaptation to the ASAP annual report.

MATERIAL PRESENTED AND DISCUSSION

Opening comments were that flight data were being continuously analyzed for maintenance action but it was conceded that there were just not enough data available yet from the four flight to refine the assumptions made - really prior to STS-1. It was stated that these studies really commenced in the definition phase beginning in 1972 and used extensive Saturn experience background.

External visual inspections on the SSME were described followed by the turbopump breakway torque and axial shaft travel pre-flight checks. Internal inspections of the entire powerhead assembly and the main combustion chamber were outlined - these consisting principally of borescope ports using both fibre-optic and rigid borescopes. Camera (35 mm) shots can be taken in some cases - mostly with rigid borescope applications. Drying purge of the combustion chamber and various leak checks were described including checks with throat plugs installed.

Electrical checks look fairly straightforward, probably the least familiar to mechanics being controller memory read-out. All the preceding checks are accomplished with the Orbiter in the horizontal position but some, such as high-pressure fuel turbopump removal are time consuming tasks as the unit has to be disconnected from its ducts etc., and slid out on "Thompson rails" (a piece of GSE) every second flight.

The Rocketdyne team at KSC to accomplish all this seems to number about 35 men, about half of whom are involved on each shift in the pre-launch activities. Some 13 technicians, 4 inspectors and 2 or 3 engineers are normally required but like all critical borescope viewing techniques the "Mark I eye-ball" confidence will probably be placed in just one or two men who possess great experience. This connotes a critical training problem as launch rates increase.

Readiness maintenance tests with the whole Shuttle assembly on the launch pad were described and a few unscheduled maintenance items have been identified. Environmental protection sets (covers) for the SSME and for the RCS and OMS engine were described, but their installation after landing is rather difficult and time consuming because of the height from the ground. More specifically, only three sets exist at present - one at KSC and the other being available to be ferried to White Sands, Hickam, Kadena, Rota or Dakar as the abort case might be. The SSME's would have to be removed to provide ferry range-weight capability out of Dakar, Hickam and Kadena.

When the craft is on the launch pad at KSC the availability of only one set of SSME GSE means that each engine at the present time has to be worked on in series. It apparently takes six shifts or approximately 48 elapsed hours to remove the old engine and install the new. The usual supporting logistics analyses including resources such as facilities, maintenance crews, training, spares, handbooks and manuals etc. appear to have been well thought out and are based upon a DOD philosophy - e.g., organizational, intermediate and depot levels and a maintenance plan has been established to suit. Training manuals have been prepared and courses planned.

MTBR studies have been made of all principle components and assemblies and engine overhauls have been scheduled based largely upon these values. Support of this wide base of materiel was said to be "in the short term" based upon existing vendors' facilities and production units whereas, "in the long term" it would revolve around "dedicated facilities and systems." The terms were not defined in years and we drew the conclusion, erroneous perhaps, that they were feeling their way both in terms of experience with the flight hardware and available funding downstream.

The all-components total MTBR plots for the period 1976 through 1980 based upon test stand data and earlier similar engine data are shown in attached Chart C-9 and Rocketdyne expressed confidence in the conservatism of these based upon their approach of factoring the MTBR value. Chart C-9 shows this overall engine life growth plotted upon a linear scale. C-10 shows the major components of the engine and the asymptotic sections beyond FY '84 are intended to indicate that they don't expect to gain a great deal of data above the fully certificated (and realized) life level. It is of significance that the most crucial components, namely the HPFTP and the HPOTP are at the bottom of the totem pole, while the LPFTP and the LPOTP are not really very much better. Much of this is due to the actual experience over the four flights and the higher FPL involved. Chart C-34 shows the estimated data replotted from October 1980 to October 1981 resulting, in effect, in a zero gain in MTBR throughout that period. In fact, the plot shows a somewhat retrograde trend but the dotted line reflects optimism which, in our opinion, may not be fully justified. Even if the life growth rates shown in C-35 are realized the effect upon available SSME spares levels could well be serious and some launches could suffer delay. The following plots (Charts C-36 through C-41) indicate the same optimism and C-38 and C-39 for the HPFTP and the HPOTP respectively should be examined carefully. There appears to be little justification for the revised "projected improvement" dotted line.

Taking the foregoing a little further and examining Chart C-52 it will be seen that the overhaul projections are rather awkwardly "bunched" especially circa 1993-1994. Rocketdyne believe that the natural occurrences of failures and other aberrations will tend to minimize some of the "bunching" and this may well prove to be true, but it is an uncomfortable precept with which to start the program. The last Chart, C-53, summarizes the expressed confidence level in terms of the halved MTBR assumptions. The principal conclusion we drew upon the basis of

the data presented is that additional spare SSME's or at least a larger spares float of high and low pressure oxygen and fuel turbopumps would provide some better insurance.

RECOMMENDATIONS (for the Shuttle program)

1. The MTBR analyses, while appearing to be very thorough in classical reliability study terms and rendered conservative by the "two times factor," do not appear to be in consort with the spectrum of early removals being experienced in the program to date. A comprehensive "best case - worst case" analysis should be considered covering the full range of reasonably possible contingencies, especially in the logistics and supply fields.
2. Results to date with a wide variety of "random failure" induced problems on the SSME indicate that the four pumps are likely to have MTBR's well below original expectations - at least for the next year or two. The high pressure fuel turbopump and the high pressure oxygen turbopump appear to be especially critical because of the limited spares available and the long lead times involved in procurement. Additional spare units would appear very desirable.
3. Planned grouping of the SSME overhauls should be re-examined to see if they could be more uniformly distributed over the period 1984 through 1994. While it is most likely that unforeseen incidents will affect the planned dispersion and tend to improve it, the present layout would appear to be prone to loss of overhaul technical skills in the workload "valley" periods and thus will run counter to safety and reliability requirements.
4. "Near term" support based purely upon "robbing" production hardware and placing reliance upon the vendors for overhaul and other technical service should be critically analyzed. The "near term" and "long term" time spans should be defined and very conscious steps taken toward the establishment of a properly based "dedicated overhaul facility," not the least

important of which will be the average age and experience level of the technicians employed. Employment stability and continuity is also an important factor in this respect.

5. From the overall safety and reliability viewpoints every possible effort should be made in planning to avoid dependence upon "cannibalizing," or robbing from production lines to meet flight date requirements. Such continuing support pressures inevitably run counter to safety because of the desire to adjust "red line," extend the life for just one more mission, and so on, to preserve intact the very expensive and highly publicly visible launch date schedules.

RECOMMENDATIONS (for the NASA-ASAP group)

It became clear in the course of the excellent Rocketdyne SSME presentation that the engine and related systems are much too highly specialized - and spread over too narrow a base in terms of the four Orbiter vehicles - to permit any other group than Rocketdyne to accomplish the overhaul and support tasks - or even for that matter, the critical pre-flight inspections. Further, it became more apparent at each logistics and support presentation that if we, as a Panel, are to really understand the enormity of this task and to make valid suggestions, we have to spend much more time on visits and studies. Certainly the somewhat intangible, but never-the-less real, effects of logistics and support philosophies upon overall system safety warrant further attention.

cc: Parmet	Attachment 1. Rocketdyne Organization Chart
Grier	2. Attendance list
Himmel	3. Selected presentation charts
Battin	

Enclosures

SPACE SHUTTLE MAIN ENGINE PROGRAM

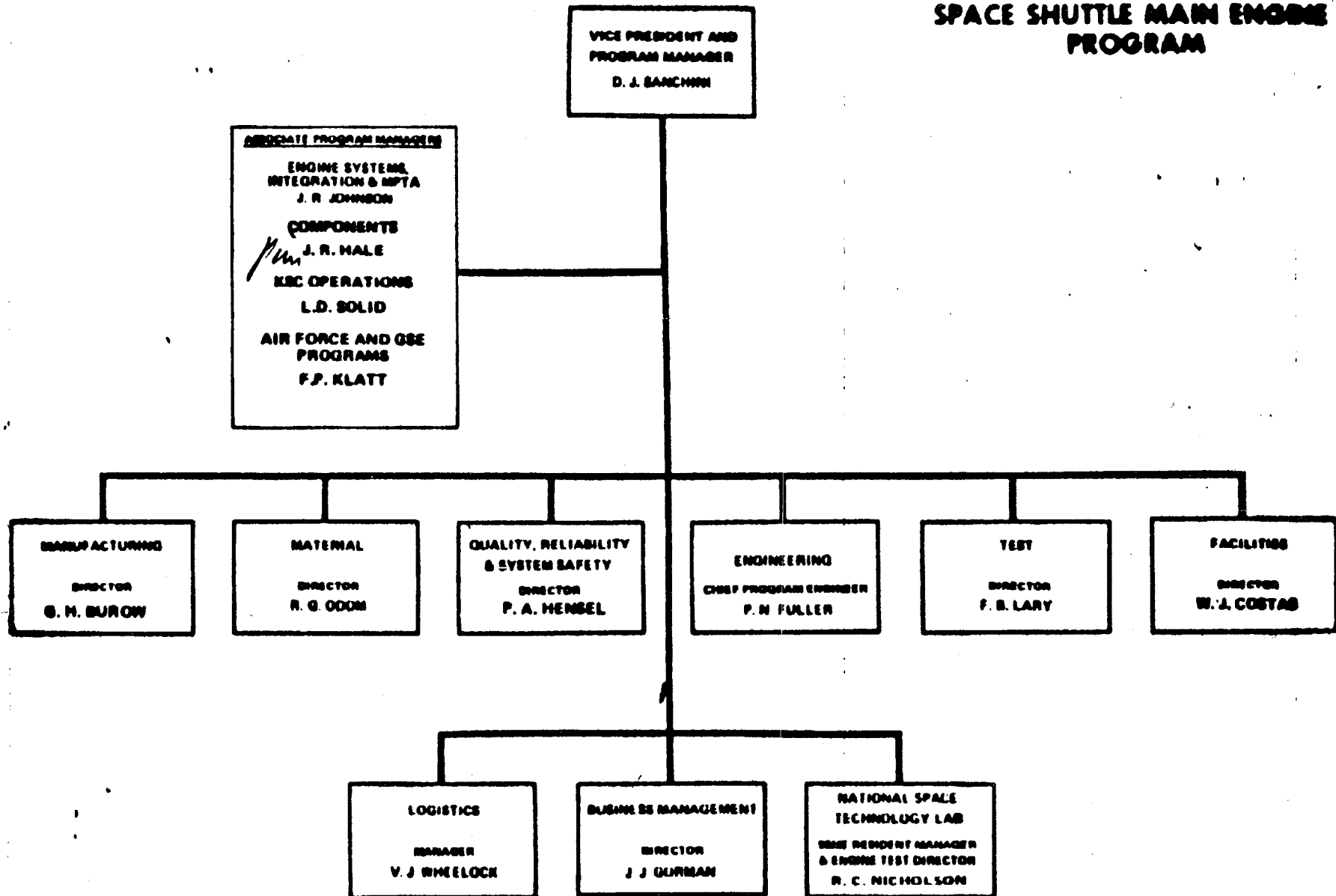

IV-5

7-27-82

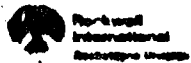

ATTACHMENT 1.

Attachment 2

<u>Name</u>	<u>Organization</u>	<u>Position</u>	<u>Phone No.</u>
Vince Wheelock	Rocketdyne	SSME Log Manager	X 2254
John F. McDonald	NASA (ASAP)		843-8311
Jerry Elverum	NASA (ASAP)		535-2374
Jack Weil	NASA/RKO	Project Mgt. Office	710-2261
Bill Mitchell	MSFC/SA-52	Logistic Management SSME Project Office FTS	872-0088
Norm Dingilian	Rocketdyne	Supply Support Mgr.	x 3095
Harvey Colbo	Rocketdyne	Schedule Management	x 3335
Frank Klatt	Rocketdyne	Assoc. Program Mgr. AF, GSE, SSME	710-3078



SSME MEAN TIME BETWEEN COMPONENT REMOVALS ALL COMPONENTS TOTAL

17-7

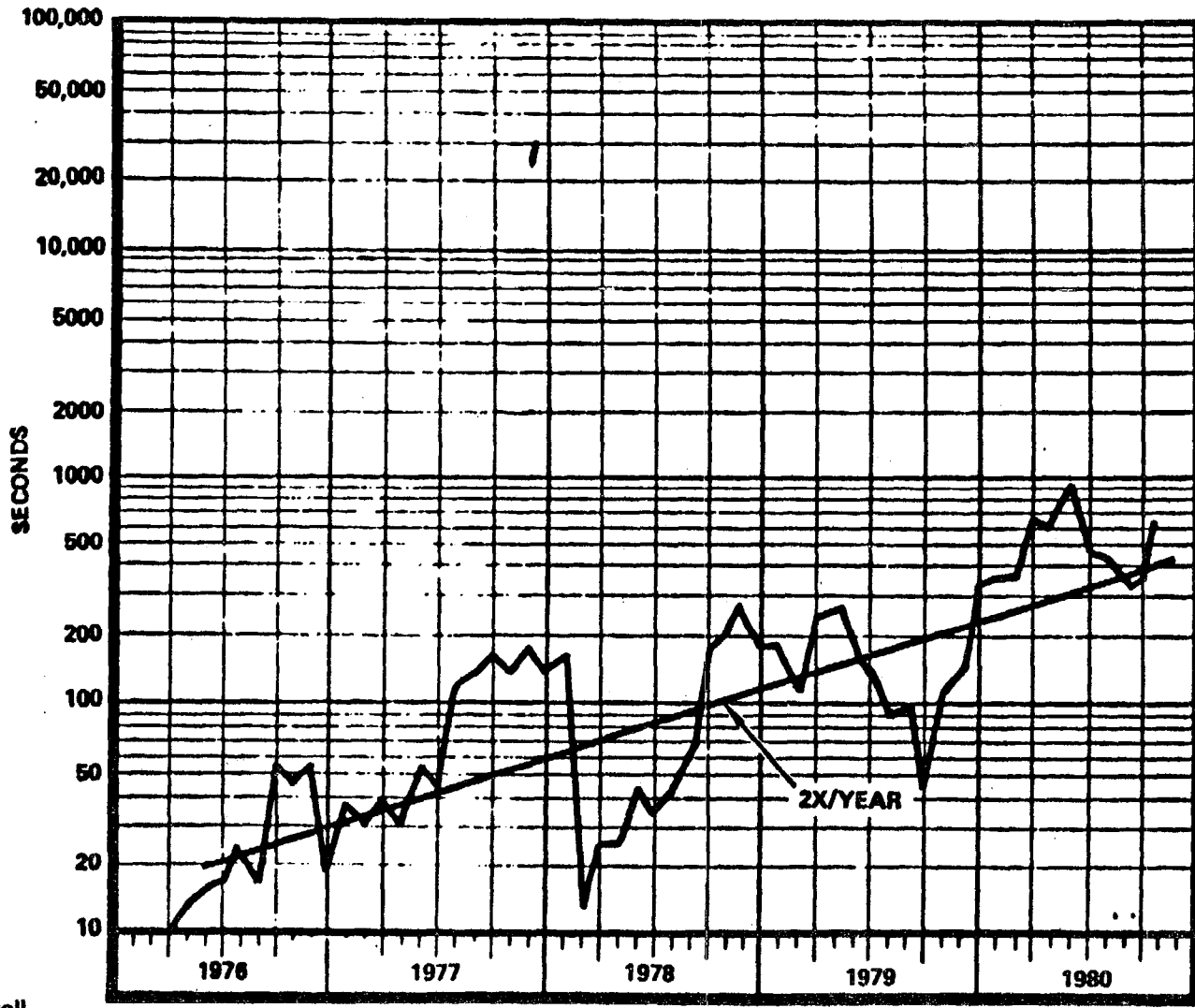

430-383A



● 3 MONTH MOVING AVERAGE



SSME OVERALL MTBR PROJECTION

3-15-82

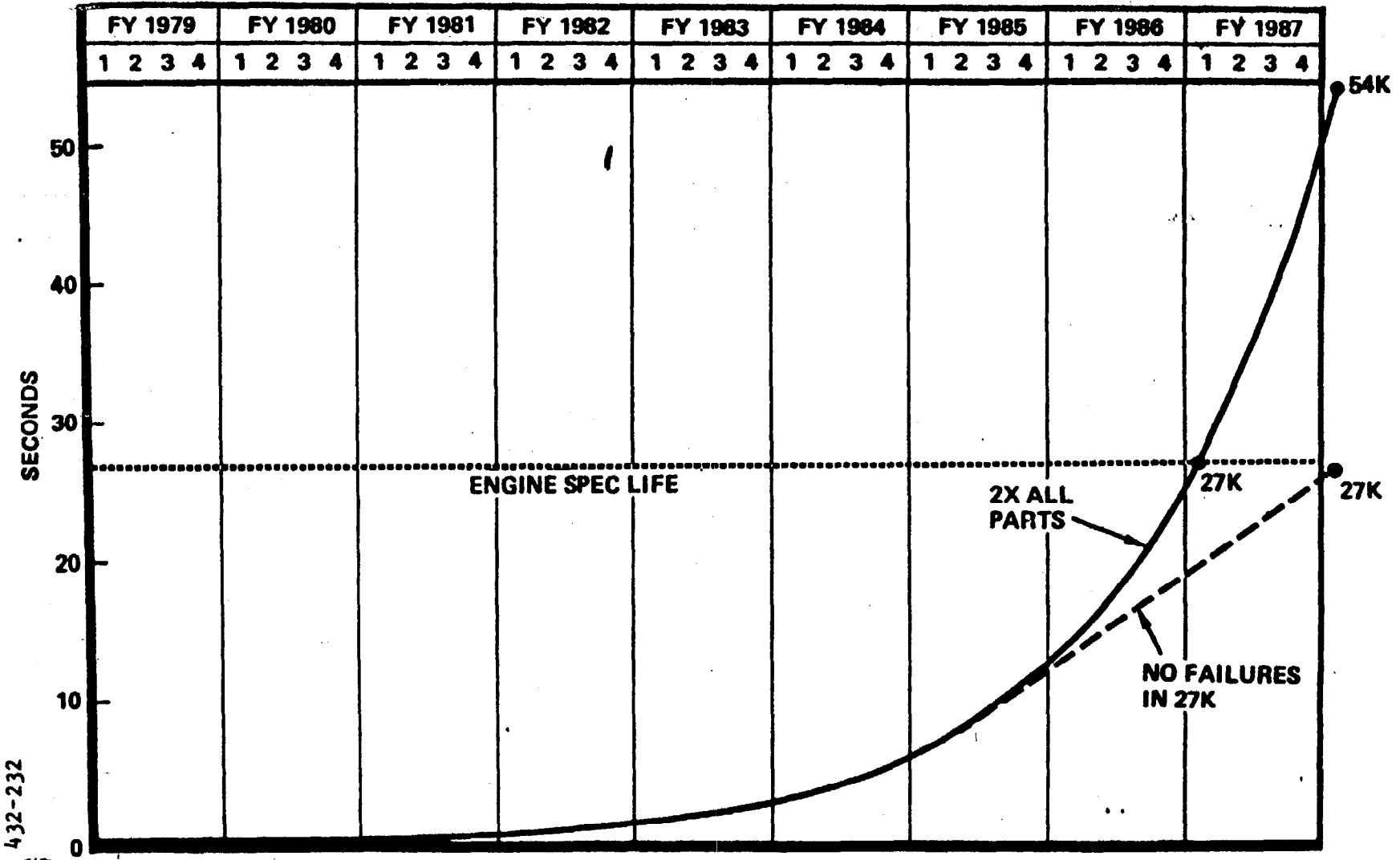

8-AI

432-232



C-9

70



SSME COMPONENT MTBR PROJECTION

3-15-82

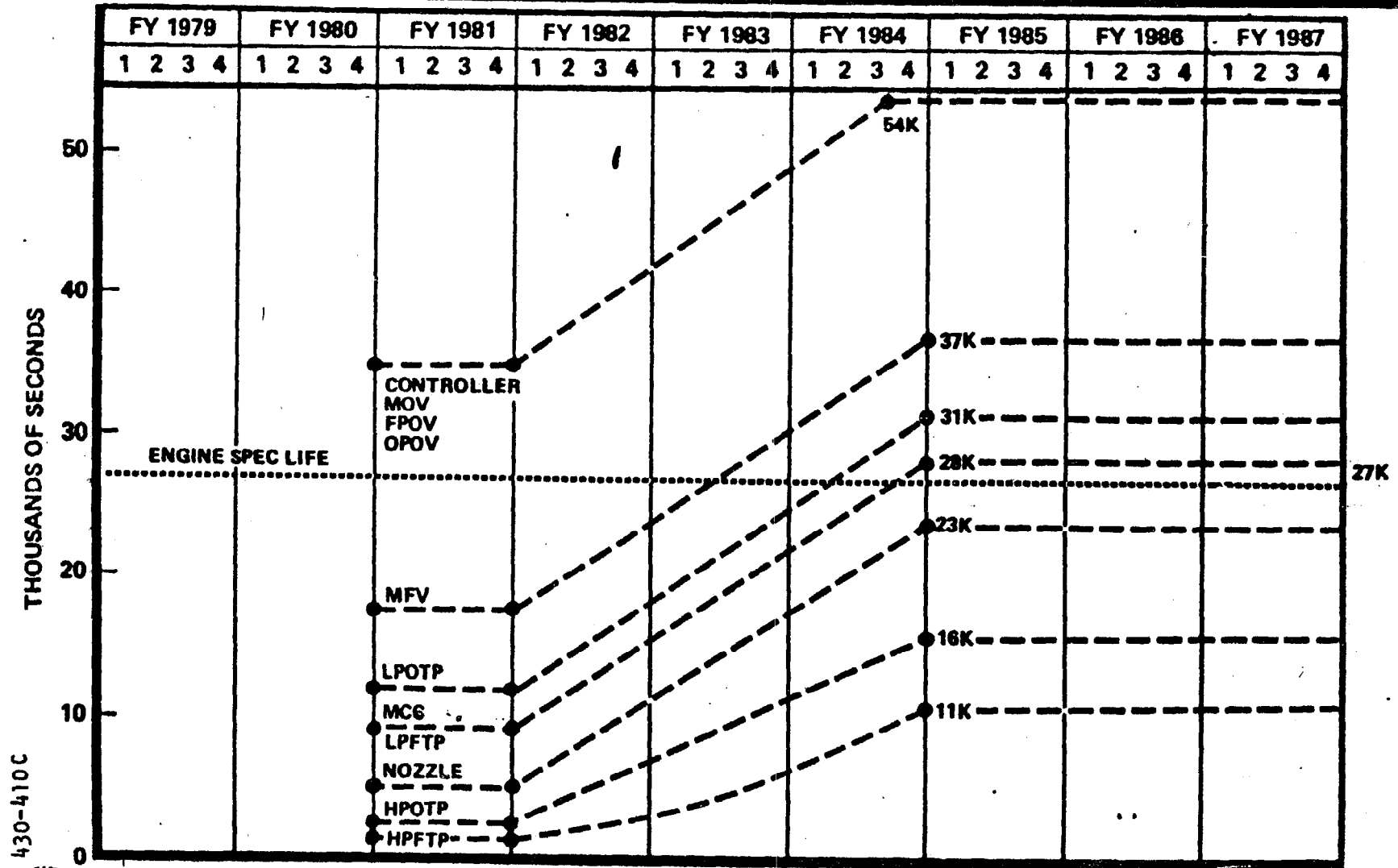

430-410C



SSME MEAN TIME BETWEEN COMPONENT REMOVALS

23 SEPT 82

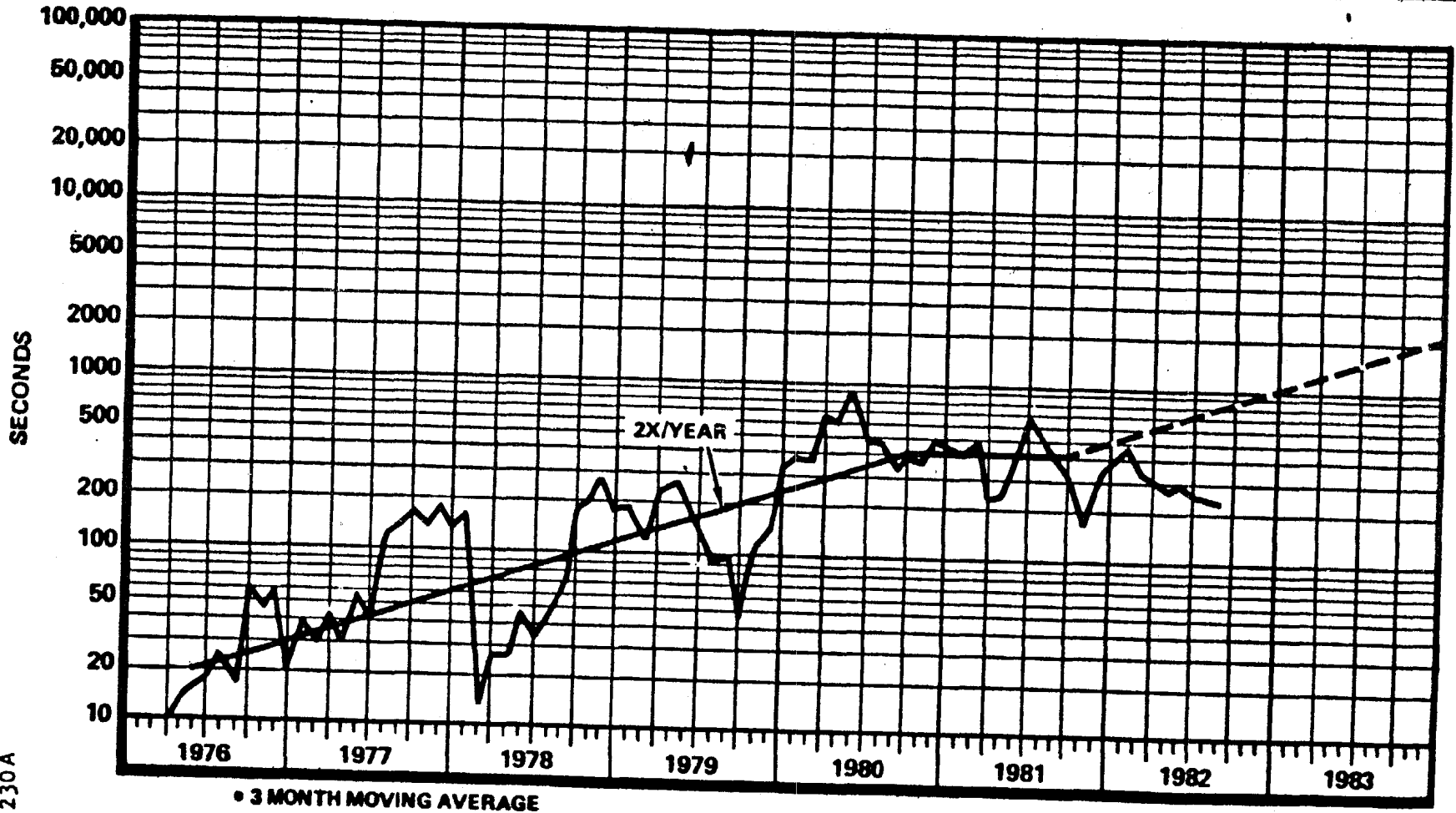

OT-AI

432-230A



72

C-34



MTBR PROJECTIONS FOR SPARE PARTS PLANNING

	<u>FY82 MTBR (SEC)</u>	<u>FY83 MTBR (SEC)</u>	<u>FY84 MTBR (SEC)</u>	<u>FY85 & SUBS MTBR (SEC)</u>
MCC	NF	NF	NF	NF
NOZZLE	30,000	30,000	30,000	30,000
HPFTP	1,500	2,000	4,000	6,000
HPOTP	2,500	3,000	5,000	7,000
LPFTP	16,000	16,000	16,000	16,000
LPOTP	8,000	10,000	15,000	20,000

NF = NO FAILURES



MCC

MEAN TIME BETWEEN REPLACEMENT

23 SEPT 82

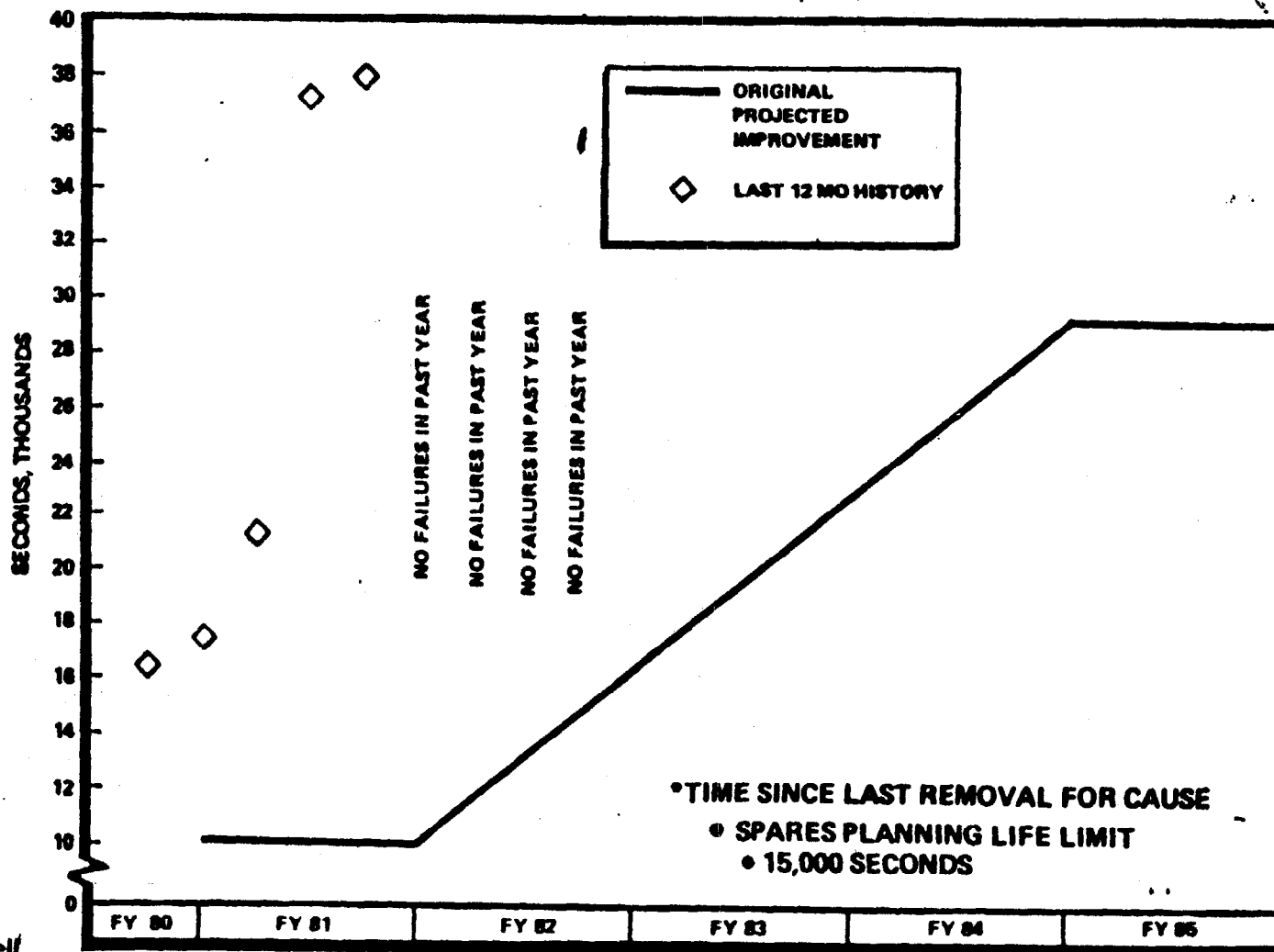

TV-12

432-235C



74

C-36



NOZZLE MEAN TIME BETWEEN REPLACEMENT

23 SEPT 82

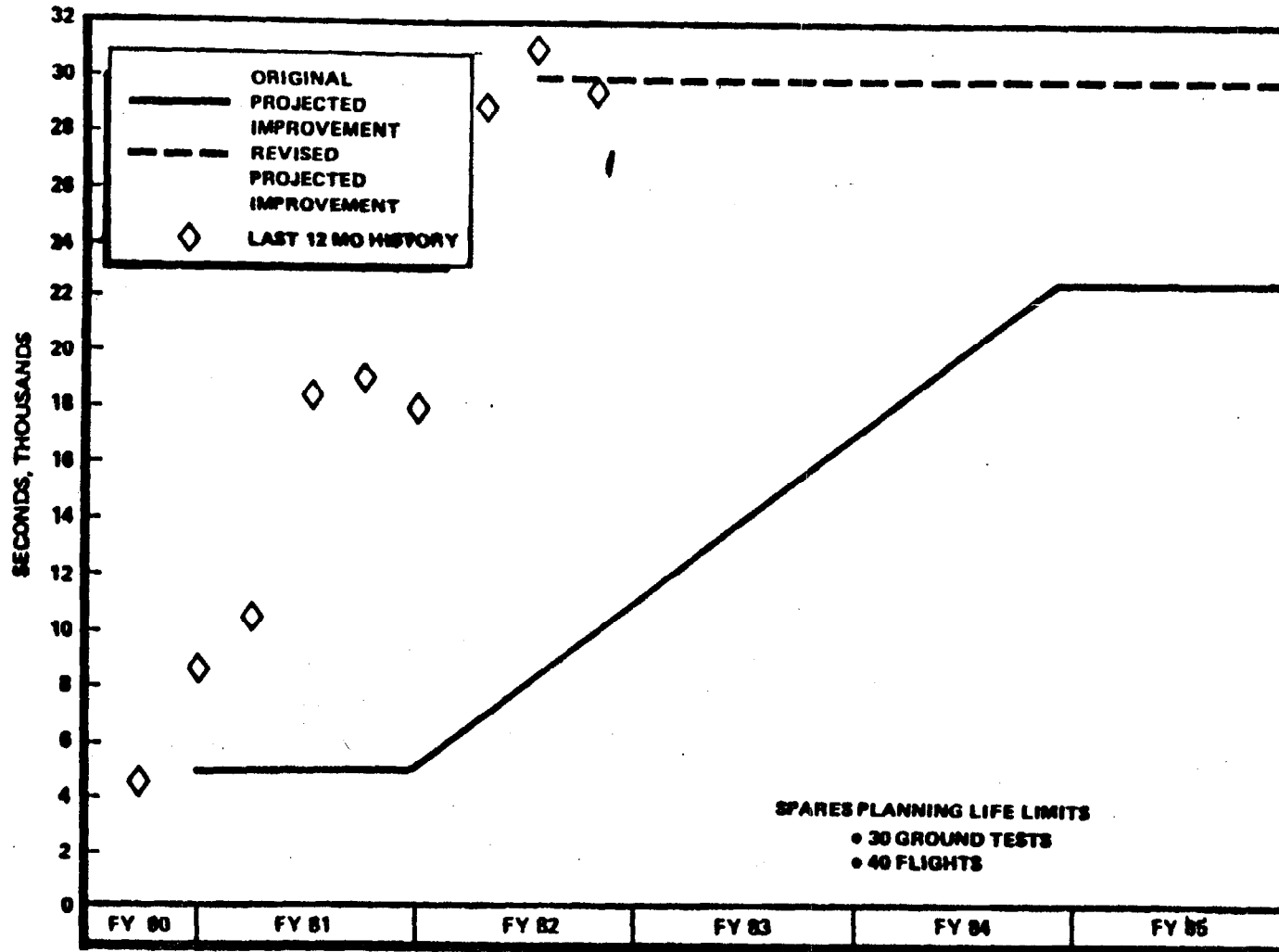

432-234B



75

C-37



HPFTP MEAN TIME BETWEEN REPLACEMENT

23 SEPT 82

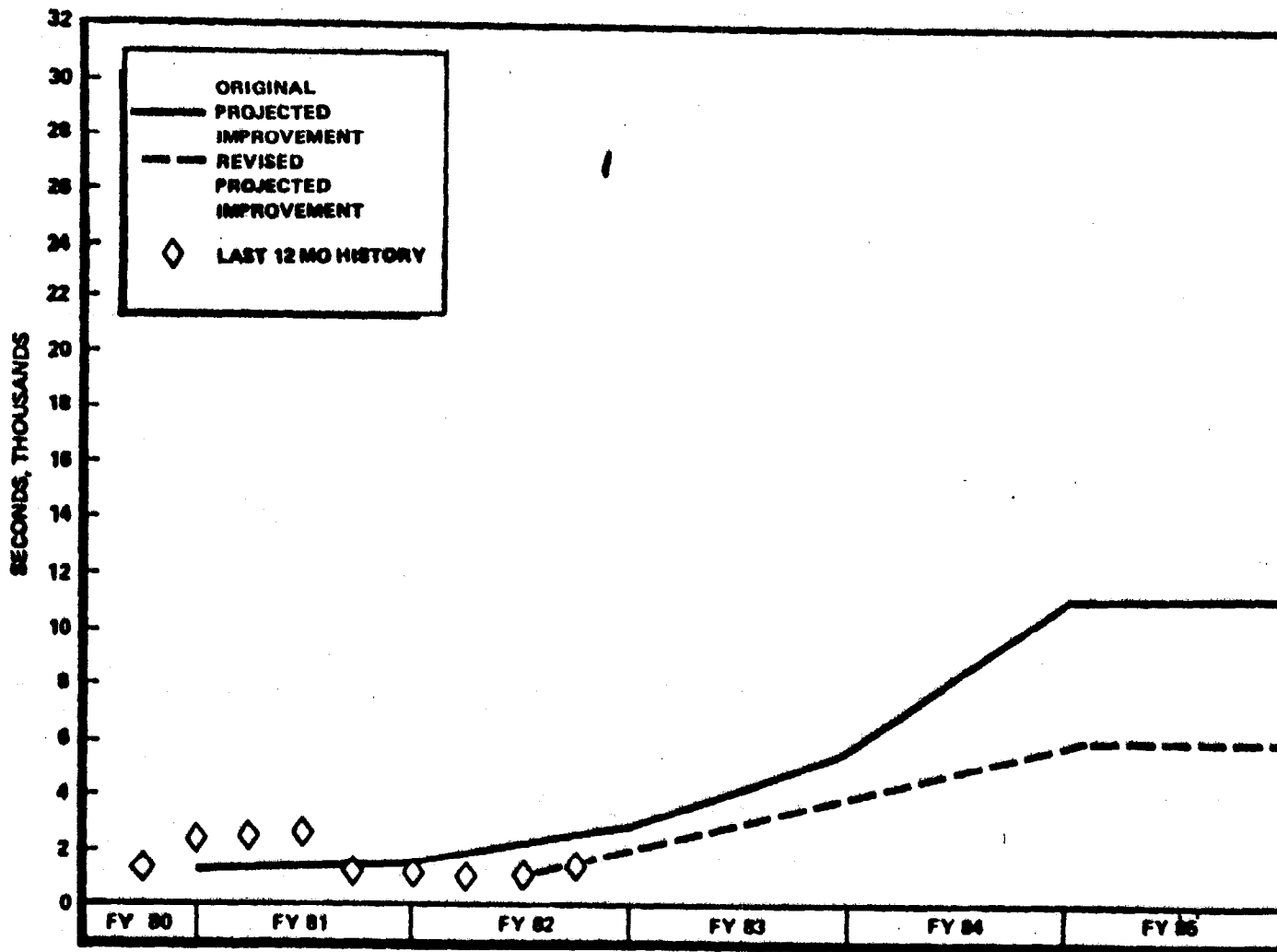

IV-14

432-236B



76

C-38



HPOTP MEAN TIME BETWEEN REPLACEMENT

23 SEPT. 82

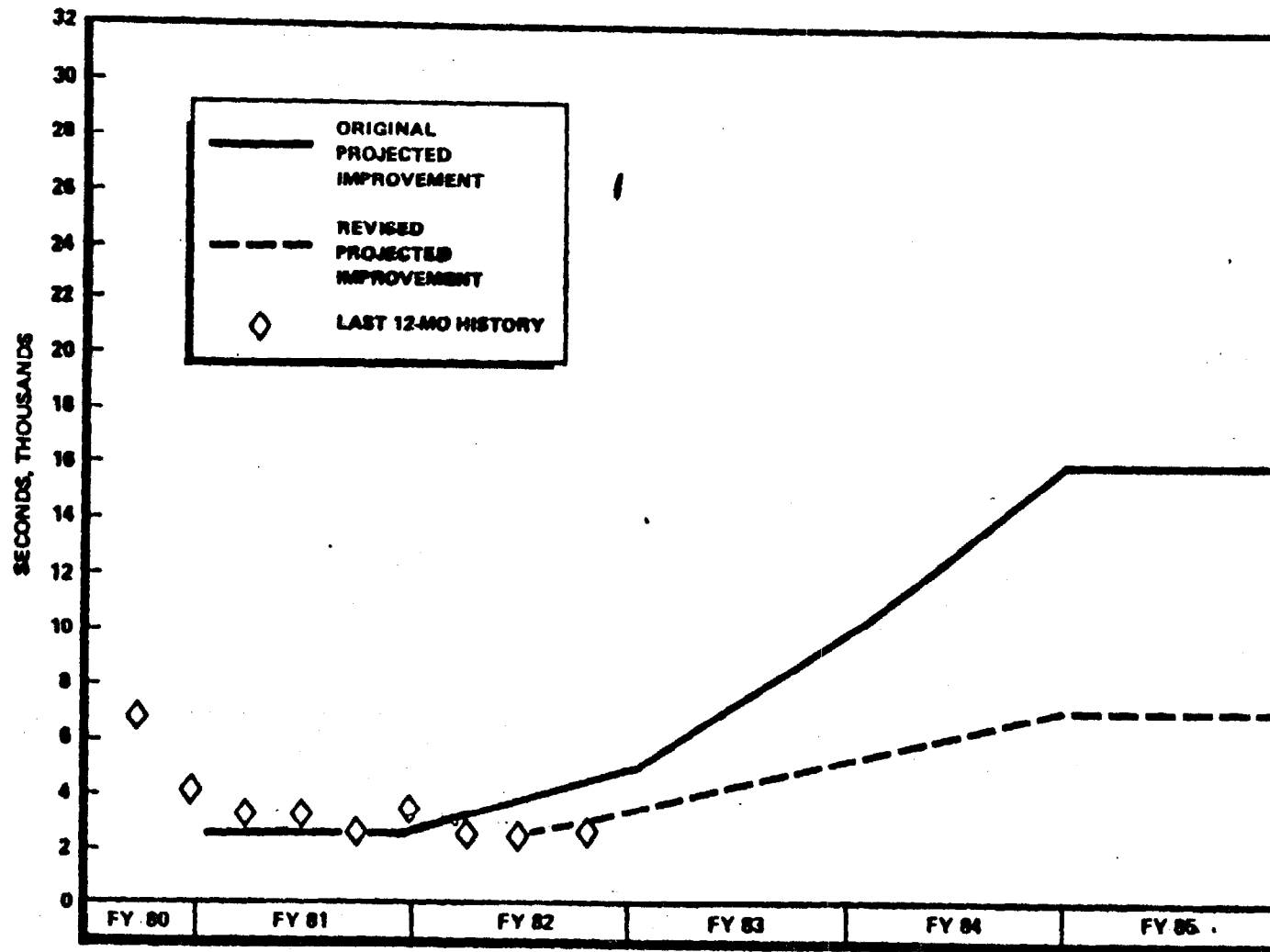

432-237B



LPFTP

MEAN TIME BETWEEN REPLACEMENT

23 SEPT 82

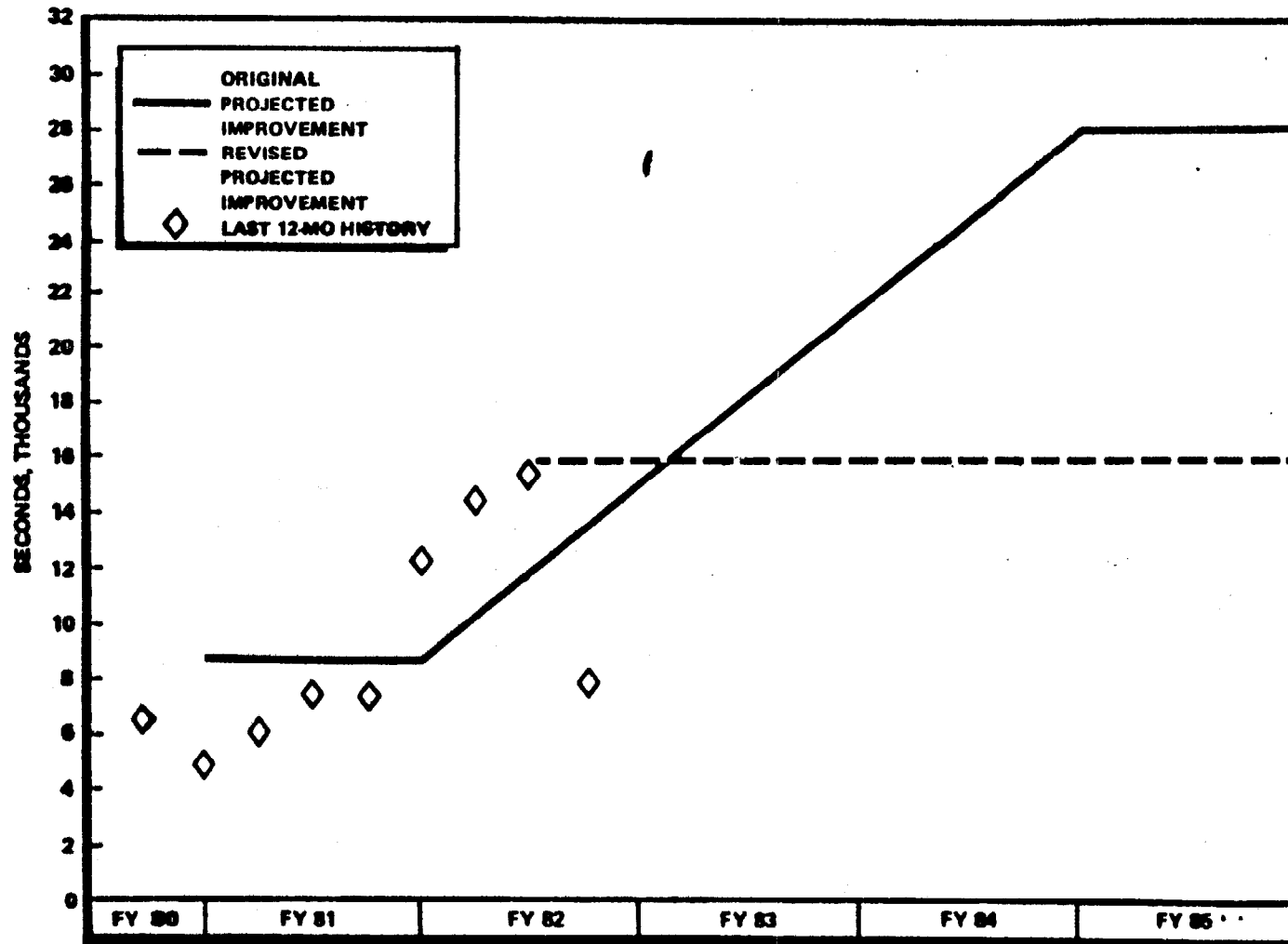

9I-VI

432-2388



78

C-40



LPOTP MEAN TIME BETWEEN REPLACEMENT

23 SEPT 82

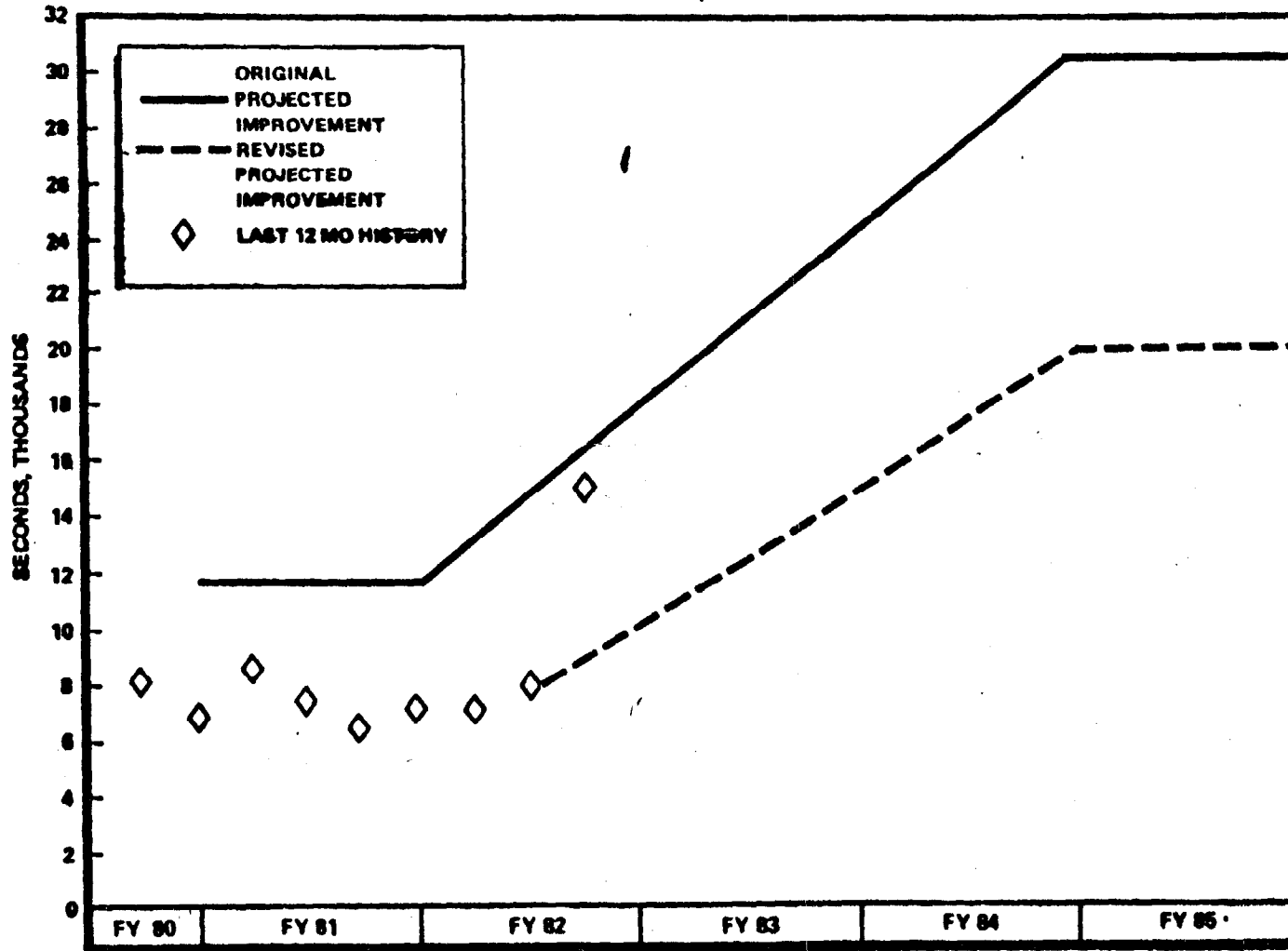

432-2398



VEHICLE/ENGINE UTILIZATION AND OVERHAUL SCHEDULE

(32 FLIGHTS THRU FY 85-24 FLIGHTS/YR MAX)

POP 82-2

6-18-82

FISCAL YEAR	80	81	82	83	84	85	86	87	88	89	90	91	92	93	94	TOTAL	
TOTAL FLIGHTS		1	3	5	10	13	17	20	24	24	24	24	24	24	24	237	
KSC		1	3	5	10	13	15	16	18	18	18	18	18	18	18	180	
VAFB							2	4	6	6	6	6	6	6	6	48	
ORBITER 102		1	3	1	3	5	5	5	6	6	6	6	6	6	6	65	
		2006, 8, 7		2017, 18, 19 (30 FLTS)						2016, 25, 27 (40 FLTS)							
		5 FLTS 8/82														65	
ORBITER 099				4	4	4	5	6	6	6	6	6	6	6	6	65	
				2011, 12, 15 (20 FLTS)					2023, 24, 25 (40 FLTS)								
ORBITER 103				3	2	2	4	6	6	6	6	6	6	6	6	53	
				2020, 21, 22 (40 FLTS)								2111, 12, 15					
ORBITER 104					2	5	5	6	6	6	6	6	6	6	6	54	
					2105, 06, 07 (40 FLTS)								2117, 18, 19				
ENGINE ASSEMBLY			2013	2011	2018	2021	2024	2027								16	
			2016	2019	2022	2025											
	2008	2015	2017	2020	2023	2026											
ENGINE OVERHAULS				2109	2105	2108	2107	2111	2112	2115	2117	2118	2119	2205	2120	2121	2122
SPARE ENGINES			2009					2026, 27			2117, 18, 19			2205, 06, 07			
				2016		2018, 2109					2108			2120, 21, 22			
					2024, 24, 25					2111, 12, 15							

IV-18

308-585U





LIFE/MAINTENANCE TESTING PLAN EXCEEDS FACTOR OF 2 MARGIN REQUIREMENTS

7-27-82

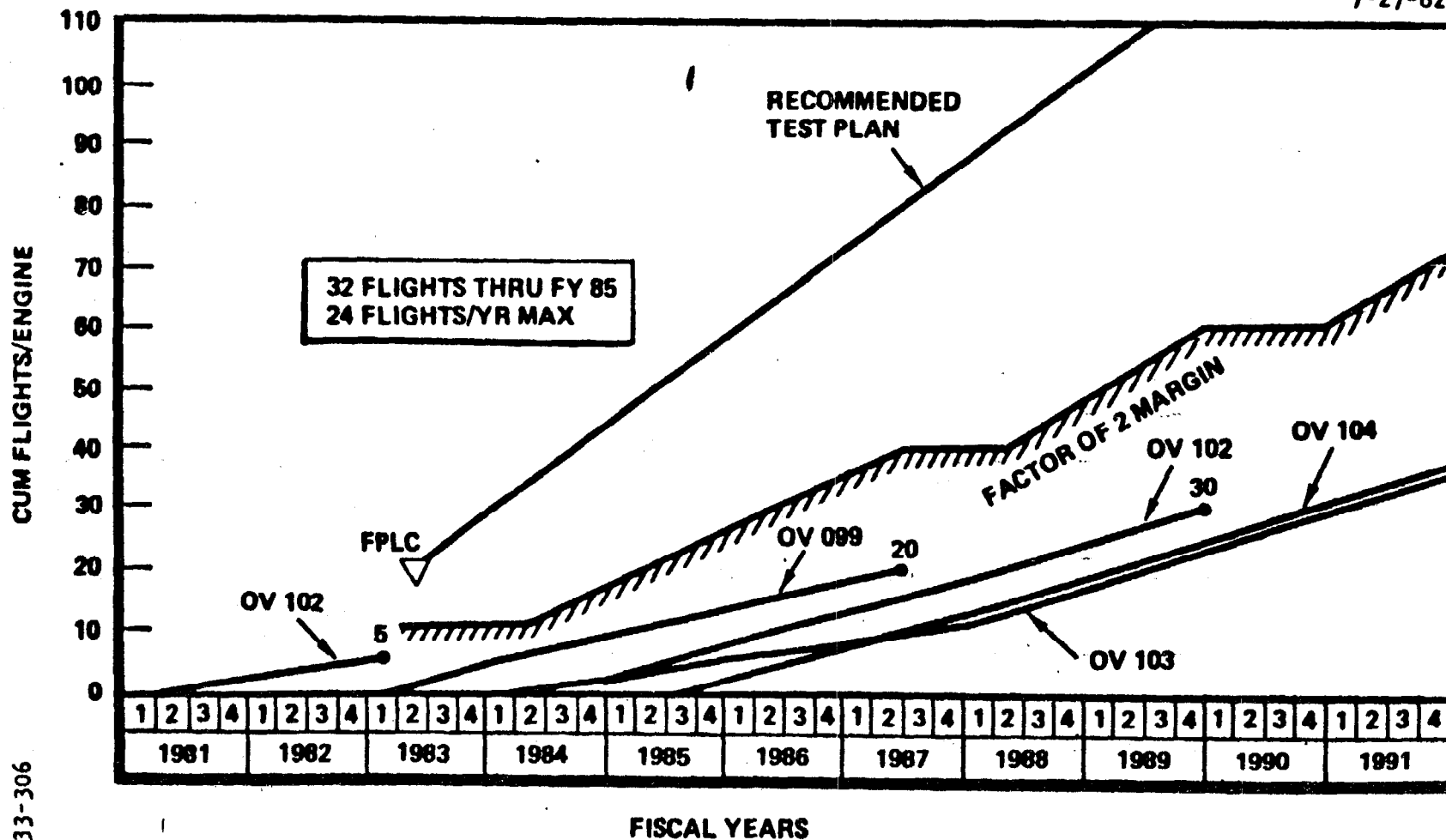

6T-AI

433-306



81

C-53

APPENDIX VNOTES ON RELATIONSHIPS OF SHUTTLE
PROGRAM TO COMMERCIAL AIRLINE LOGISTICS1. INTRODUCTION

Now that STS-5 has been completed and with OV-099's first flight drawing near, some of the potential problems in logistics, spares and support can be viewed in somewhat clearer perspective. This rather rambling and discursive commentary represents some observations made in the light of extensive airline experience, both in operating and design fields. Some viewpoints are undoubtedly contentious and represent only the writer's opinions and not necessarily those of the Aerospace Safety Advisory Panel as a whole.

As in an airline, the relationship of overall safety to logistics and maintenance for a continuously operating Shuttle fleet is absolutely central. It is perhaps more so because the national prestige and multi-million dollar business commitments to established launch dates make it imperative that these will be met in a planned and orderly support manner, rather than by "cannibalizing" and borrowing from the production line. At the extreme end of this launch-at-any-cost spectrum would be the unwise extension of major component overhaul life or the expedient adjustment of operating "red lines."

At some point there must be a transition from the traditional NASA R&D mode to a rational operational pattern but there can be little comparison to that of a safe and successful airline. Some of the issues in these differences will be discussed later, but the major paradox in the Shuttle program appears to be that maximum utilization, amounting to a

projected twenty-two day turn-around (Ref.1) will occur circa 1990 when many of the support and supply sources will have dried up. Even in the so-called "near term" there is an obvious paucity of airframe and engine spares, exacerbated by the unique nature of the components and the lengthy lead times entailed in ordering and manufacturing them.

2. THE SMALL FLEET

The fleet size of four Orbiter (or five if OV-105 is ever funded) is such that, if any comparison to airline terms were possible, a fleet of say four B-747 aircraft would be considered impractical from the economic viewpoint. About the only way in which such an airline fleet could be made acceptable from the maintenance and support viewpoints would be to become a hypothetical part of a larger carrier's fleet of B-747's and to "piggy-back" on those maintenance programs. Obviously nothing of the sort is applicable to the Shuttle program and the airline-Shuttle comparison therefore becomes somewhat academic and misleading. There are, however, some airline control and management techniques which could probably be transplanted with advantage.

Small airline fleets of large, specialized aircraft depend heavily upon spares pooling arrangements, common engine and major component overhaul facilities, and the like. They have a grand common denominator with other carriers in that the prime manufacturer obtains, resolves and distributes maintenance operating data - especially safety related issues - from all sources. This is reinforced by the regulatory activities of the FAA and thus there are probably more "checks and balances" than could ever be possible with the nature of the Shuttle program. Consequently it would appear that the tightest overall program management control possible will only be just good enough for the Shuttle in the absence of some of the advantages cited.

3. THE DETAIL DIFFERENCES IN VEHICLES

One of the inherent problems of a fleet of vehicles which are almost alike is that it requires special vigilance to avoid the mistakes of apparent maintenance familiarity. For example, in the case of an actual B-757 fleet of the writer's acquaintance there are now, in seventeen aircraft no less than five gross, landing and zero fuel weight combinations, four different engine configurations (all Pratt & Whitney), four different cockpit layouts and it is difficult to find more than two aircraft for which you could use the same wiring diagram manual. The moral to this story is that it is infinitely more difficult to manage systems which are almost alike and this canard applies equally to the four Orbiter OV-099, 102, 103 and 104.

Comprehensive individual wiring manuals are essential, rather than recourse to masses of blueprints to unravel the differences at the flight line or launch pad level. This will become a sine qua non around say 1990 when some of the continuity of the devoted cadre of experts has disappeared through attrition and retirement. Economies in maintenance publications now will reap their own negative reward later, but a format like the airlines' universal ATA Spec. 100 series offers great flexibility in permitting the operators to do their own revisions without the requirement for off-set printing.

4. THE INABILITY TO "BORROW" SPARES

One of the interesting characteristics of large commercial carriers is that, while competing intensively on the traffic route and fare structure fronts, they do, in general, co-operate with each other to a remarkable degree on the maintenance and engineering fronts. The IATP (International Airline Technical Parts Pool) system, initially organized

under IATA airline auspices, is a good example of this highly developed interchange system but its roots are, of course, in the degree of common units and parts between each of the carriers, including the use of each other's engines upon specified rental and return agreement terms. Clearly no such advantages are possible with the unique nature of almost all of the functional system components of the Orbiter and its supporting ground systems, but the purpose of this recital of the obvious is to avoid the danger of making logistics and spares support comparisons which are significantly influenced by airline techniques.

Airline methodology has certainly some lessons which could be of value to the Shuttle program but in this instance it is more likely that military techniques (shorn of some of their traditional overbuying excesses) would provide a better model. The comparatively leisurely utilization rates (in peacetime) would seem to provide a more accurate counterpart from the specific viewpoint of spares, although the length of the supply lines for the Shuttle involve a great deal of expedited special air transport methods - especially critical as turn-around time become shorter.

5. THE SLOW RATE OF MATURING (LOW UTILIZATION)

Since the fleet base of the Orbiters is so small, and the rate of accumulation of hours and cycles so slow it may well be that the entire system will barely attain real maturity co-incident with obsolescence. This problem is intensified by the very low number of test hours compared with the development of a commercial airline and particularly by the absence of a broad "service test" phase among many different operators all around the world. Even so, commercial airlines occasionally suffer disastrous problems at a stage when it

would be reasonable to assume that the entire structure and functional systems had reached maturity. There is also the reverse situation to attaining maturity in which increasing age has uncovered unexpected problems necessitating major remedial programs especially in structural aspects.

Maturity of the SSME will probably be interrupted by the use of progressively increasing power levels necessitated by payload demands. Any support program should guard against excessive optimism in terms of anticipated and uninterrupted linear development of MTBR and MTBF values. The HPOTP and the HPFTP pumps are especially critical in view of their extraordinarily high performance with respect to material temperature limits and operating margins. The complete engine test stand facilities offer few alternatives in the event of damage due to an uncontained failure, which, it would seem statistically is likely to happen with the number of engines in the entire program through, say, the year 1990.

6. THE UNEVEN PREDICTED WEAR-OUT POINTS

The multiplicity of functional components in the Orbiter are at least double and probably closer to triple those in a large commercial transport aircraft. A large proportion of these are of brand new design and it is going to be extremely difficult to rationalize the preventive maintenance programs in terms of MTBR and MTBF to suit. A sophisticated aircraft like the Lockheed L-1011 would probably provide the best comparison but even so most of the functional system components in this case are derivatives of earlier designs and thus there has been a broad historical base upon which to predict an initial maintenance program which could be acceptable to the FAA's MRB - Maintenance Review Board - see Ref. 1) at the outset of operations.

To achieve an equivalent degree of confidence at the

commencement of Shuttle operations is plainly not possible but the vital nature of this data foundation gleaned every piece of experience, test and early use information in a collective and systematic way for the entire system - would appear to be imperative especially in view of production lead times and batch size impoverishment. The magnitude of the task of producing comprehensive FMEA's (failure modes and effects analysis) for all critical components may result in an encyclopedic paper analysis which will be completed too late for economic supplies re-ordering. The judicious use of actual flight-line experience rather than somewhat abstract analyses should therefore be encouraged and some spares procurement gambles made as a form of insurance for the 1990's. Obviously the MEA's for the selected list of critical high-value components must be completed first.

7. DATA FEED-BACK FROM OPERATOR TO PRIME

The mechanism of operating experience data feed-back from the Shuttle operations groups to the prime manufacturers warrants some discussion insofar as its relationship to an airline is concerned. In the airline case the aircraft manufacturer not only collects all his own data from his resident representative upon airframe problems but also acts as a "clearing house" for information on all significant vendor component problems. Some of the larger vendors also have their own representatives at the main airline base. This information chain is constantly endorsed by a lively defect reporting system produced by the airline itself and the whole process is enforced by the sometimes unwelcome attention of the FAA who have their own series of safety related directives and reports.

Parallels of some of the above do not appear to exist in the Shuttle program but, on the other hand, some of the liaison engineering procedures are probably more closely coupled,

especially in the R&D phase. The presence of such large groups of contractor personnel at KSC, for example, at every launch has not parallel in commercial airline operation. In the airline case a small introductory team of factory experts is invariably stationed at the main M & E base for the first few months. These groups include personnel who can help establish the entire maintenance and overhaul programs for the airline operators and assist in securing FAA operating approval if necessary.

Since NASA and the prime contractors appear to act as their own "police force" - there being no counterpart of the FAA - the overall perspective of data reporting requirements may not be as clear as in the commercial airline case. This will be especially true when the craft have been in operation for a decade or more and are considered to be a "mature system." The danger of dedicated channels of information from the larger prime contractor contingents at Kennedy and Vandenberg for the rather exclusive use (even if unintentionally) of the principal factory always exists in a program wherein the manufacturer-operator relationships are manifestly incestuous.

8. THE SPC PHILOSOPHY - STRENGTHS AND WEAKNESSES

The Shuttle Processing Contract philosophy now being developed deserves some comment, particularly because, as a concept it has arrived rather late in the day. Clearly it will not save money as opposed to leaving the processing activities in the hands of knowledgeable and responsible prime contractors. What it can do is to try to makeup for some of the inherent shortcomings of such a small-fleet-base R&D pattern but it must consciously avoid the danger of internecine warfare, especially in information channels. It would appear that since the transfer of experience of the launch techniques must inevitably involve the acquisition of

some key personnel, there would perforce be some "pirating," at KSC in particular. Perhaps this would be necessary eventually in any case to permit NASA to disengage itself progressively from its all-absorbing Shuttle role and move on to other programs.

The greatest inherent weakness in the SPC approach seems to revolve around the extraordinarily specialized nature of the Orbiter and the learning curve issues which are germane thereto. Equipment knowledge and overhaul repair techniques and facilities are so specialized and unique that it would seem to be impractical, for example, to every subcontract the support of the SSME's to any group other than Rocketdyne (see Ref. 3). There must be other crucial systems in the Orbiter of the same nature, that is to say, cases in which attempts to transfer authority for apparent contractual advantage would prove unproductive.

9. SUSTAINING ENGINEERING

The somewhat euphemistic term "sustaining engineering" seems to embrace a combination of the function of what the airlines know generically as "engineering" and the manufacturer as "customer support" - or at least the in-service modification and development engineering aspects of support. The tendency among the larger trunk airlines today is to reduce their own airline engineering activities (reductions from approximately 150 persons to 35-50 during the past three or four years being not uncommon) and depend more heavily upon the manufacturer's support engineering services. Top airline management personnel are now more frequently of a legal or financial persuasion and the era of major influence of the key engineering personality has gone (see Ref. 4). Consequently the likelihood of bigger airlines doing their own corrective engineering re-design, as was the case in the early post WW II period has disappeared upon economic

grounds, and the situation may have some sort of applicability to the Shuttle program.

To the outside observer of the Shuttle program it appears that a degree of investigative engineering is being done on both sides of the house - NASA and the prime contractors. In the present R&D phase this is undoubtedly the right course to pursue but when NASA eventually moves into being the operator it would appear logical to keep the corrective engineering responsibility squarely with the prime manufacturer (if their prices aren't too impossibly high!). This field of "sustaining engineering" will be in need of careful delineation of interface relationships under the SPC concept to avoid duplication of responsibilities or worse, abdication.

The commercial transport aircraft is in reality a very complex and therefore imperfect machine made practical to great extent by the skills of the mechanics and technicians who maintain them. This is also true to a somewhat lesser extent for military aircraft, but since the design is almost never optimum the maintenance and operational people have to circumvent the shortcomings by ingenuity and adaptability - a process sometimes known rather grandly as "the learning curve." It is frequently true that there is not, and should not be, a solution to every problem by redesign. Indeed, the smaller the vehicle fleet basis the less practical it is to start upon a redesign in cases where operator ingenuity could alternatively solve the problem. In short, "sustaining engineering" activities should be examined and re-examined and where they have no effect upon safety they should be reviewed through the "pay-back criterion" bearing in mind that nine-tenths of all cost-effectiveness justifications of this type are illusory in the full term.

10. SUMMARIZING COMMENT

If one should be unwise enough to try to summarize such admittedly unsupported impressions as the foregoing, the encapsulation would be something like the following. If nothing else some of the points might provide stimulus for future discussion.

- a. The Shuttle program does not appear to have the amount of spares that an airline would require at a comparable period in the operational development of a new fleet.
- b. It would appear that, due to the specialized and unique nature of the Shuttle program more, rather than less spares would be needed, than for an airline.
- c. The maintenance publication programs must not be curtailed as a cost-saving expedient - otherwise we shall pay for it later in continuous delays and possibly safety.
- d. An overall maintenance control program covering all aspects of Shuttle program including the entire propulsion system along the lines of an FAA Maintenance Review Board should be prepared.
- e. The Shuttle Processing Contract concept is already late and if it is not to be implemented until the end of 1983 some irrecoverable lead time will be lost. Alternatively, some expedient gambles on spares procurement should be taken by the existing channels now to reduce cannibalization and borrowing from the production line.

REFERENCES

1. "Shuttle Ground Turnaround and Launch Projections"
by George Page, NASA KSC October 27, 1982 (at JSC).
2. FAA Advisory Circular AC 121-22 Maintenance Reveiw Board
(MRB).
3. Memorandum: Elverum and McDonald to W. M. Hawkins -
NASA-ASAP visit to Rocketdyne, Canoga Park, September 29,
1982.
4. "The Sporty Game" by John Newhouse published by Alfred A.
Knopt 1982.

ORBITER ESCAPE CONCEPT

CONCEPT:

- BASED ON YANKEE SYSTEM DEMONSTRATED IN EA³/B STENDEL SLED TESTS (FB-44)
- REAR SUPPORTS FLAT ON ASCENT WITH FOLD-DOWN (BICYCLE) SEAT FOR ENTRY
- A PROPERLY DESIGN STRAP SYSTEM COULD ELIMINATE ANY FOLD-DOWN SEAT REQUIREMENT ON ENTRY
- COMMANDER AND PILOT SEATS SLIDE BACK ON RAILS FOR EJECTION ESCAPE
- REAR SUPPORTS FOLD UP FOR STORAGE IN ORBIT
- SEATS/SUPPORTS CONTAIN ROCKETS, PARACHUTES AND STRAP SYSTEMS

OPERATION:

- BLOW HATCH AWAY
- EJECT FOUR REAR CREWMEN
- SLIDE FRONT SEATS TO REAR
- EJECT COMMANDER AND PILOT
- ~ 2.0 SECONDS OR LESS BASED ON SLED TESTS

BENEFITS:

- FLAT-BACK SUPPORTS MORE COMFORTABLE ON PRELAUNCH/ASCENT AND WITH STRAP SYSTEM ACCEPTABLE ON ENTRY
- ENTIRE ESCAPE SYSTEM (SUPPORTS, ROCKETS AND CHUTES) CONSIDERABLY LIGHTER THAN PRESENT SIX STEEL ORBITER SEATS

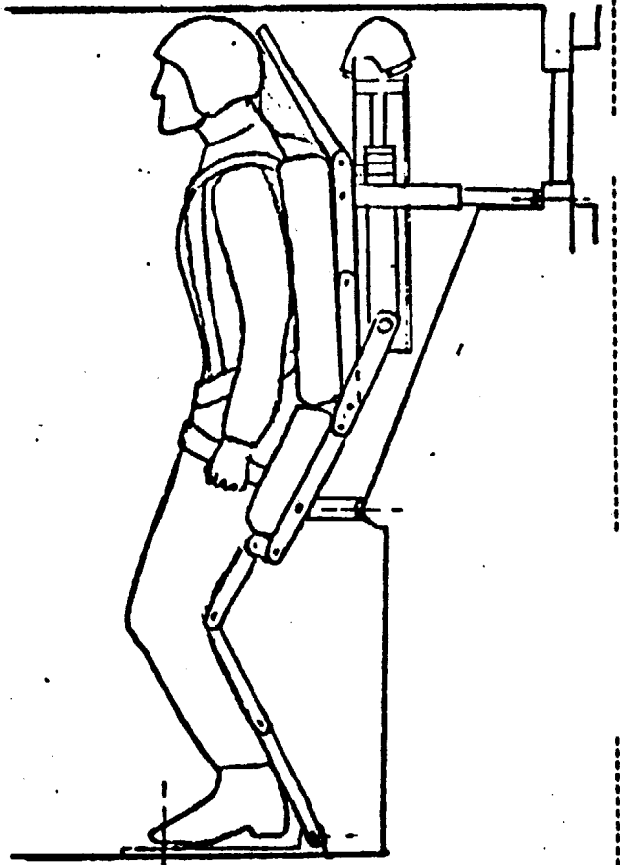
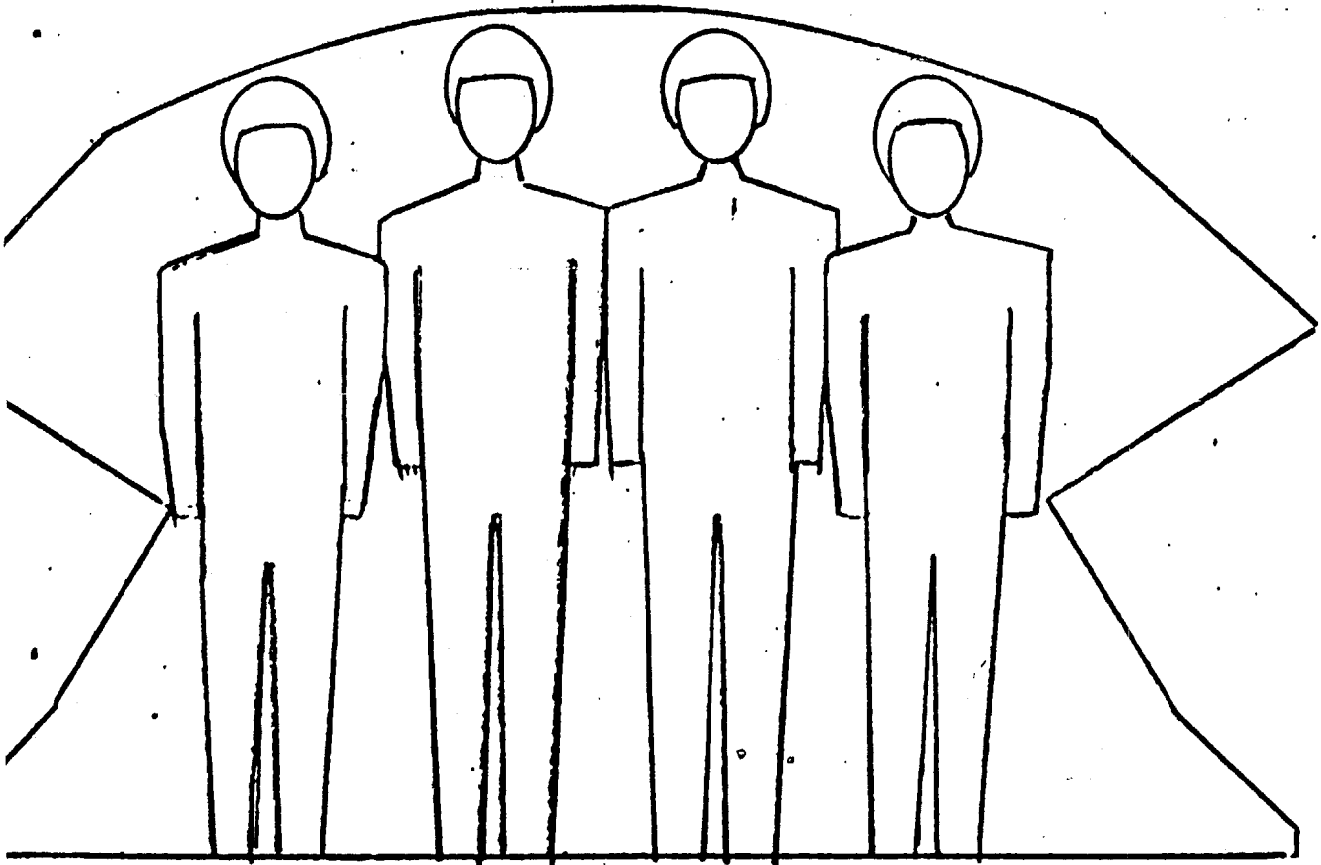

SHEET NO. 94
JOB NO.
DATE

ORBITER ESCAPE CONCEPT

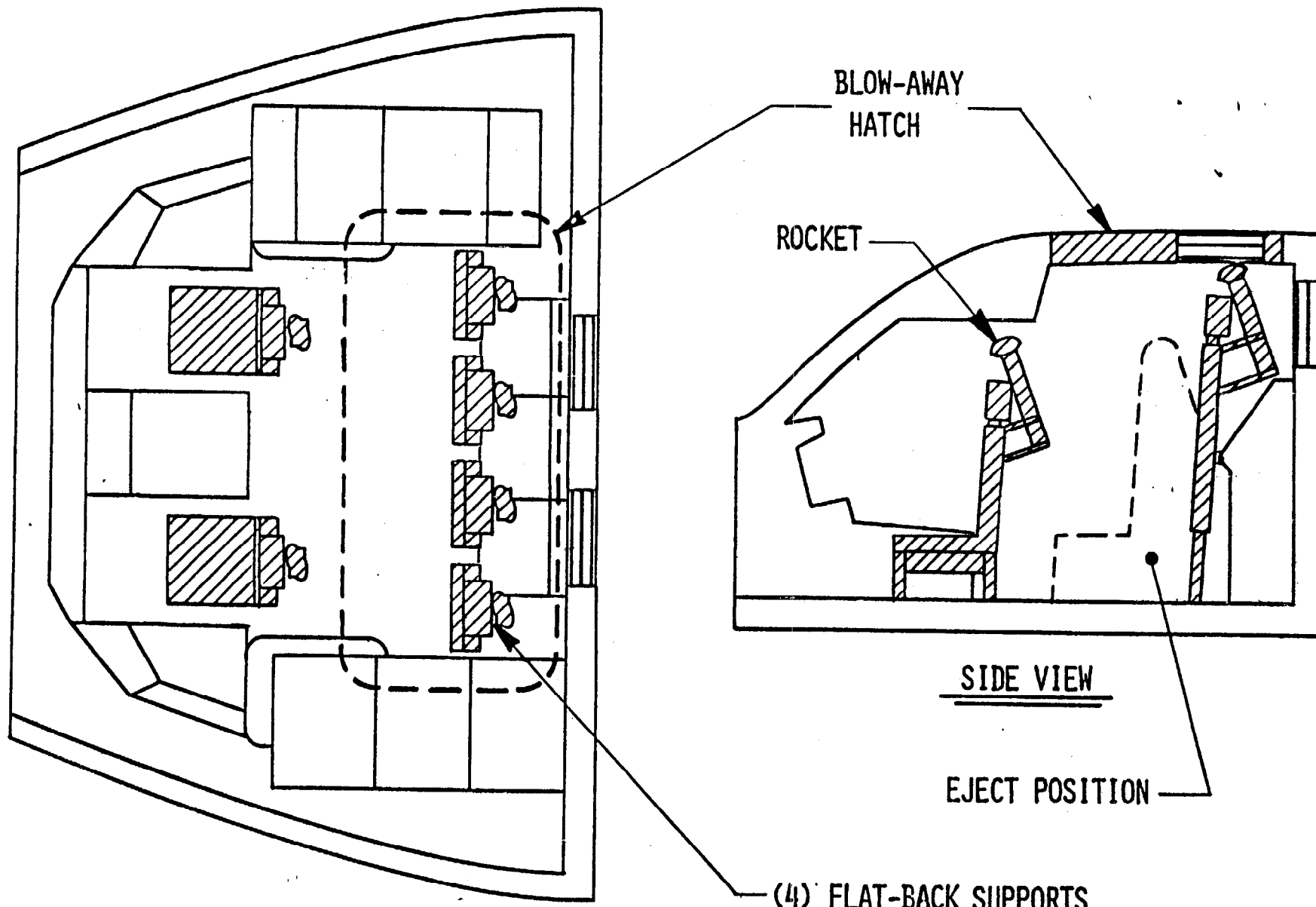

TOP VIEW

BLOW-AWAY
HATCH

ROCKET

SIDE VIEW

EJECT POSITION

(4) FLAT-BACK SUPPORTS

RELATED SYSTEMS

<u>AIRCRAFT</u>	<u>SYSTEMS DELIVERED</u>	<u>LIVES SAVED</u>
A-1E	220	30
A-1G	40	
A-1 H/J	204	33
T-28	56	17
T-28 MAP	43	
T-28D-10	144	NO DATA
RSRA	6	*
A-300	1	*
LEARFAN	3	*
ENFORCER	3	*
<i>GERMAN FAN TRAINER</i>	<i>100</i>	<i>1/84 DELIVERY</i>

* HAS NOT BEEN USED IN EMERGENCY TO DATE

SEPT 82

APPENDIX VII

Mr. Willis M. Hawkins
Senior Advisor
Lockheed Corporation
Burbank, CA 91520

September 13, 1982

Mr. James M. Beggs
Administrator NASA
Washington, DC 20546

Dear Jim:

During one of the past meetings you asked the Aerospace Safety Panel to review the safety aspects of flight operations at the NASA Centers. Lee Davis of the ASAP accepted the assignment and has now visited Langley, JSC, Ames, and DFRF. His recommendations are as follows:

a. Walter Williams addressed this subject in March. His recommendations are sound and should be implemented, specifically:

- (1) Headquarters NASA should update and issue Management Instructions 7910.1 and 7910.2. (The ASAP would be happy to review drafts before official issue.)
- (2) The Intercenter Operations Group (ICOG), consisting of the flight operations chiefs should be reconstituted and meet quarterly to exchange information on operational and flight safety problems.
- (3) Flight Safety should be recognized as a distinct discipline and experienced pilots should be assigned to

assist the Flight Operations Chief at each Center in fulfilling his safety responsibilities.

- (4) Flight Test Engineering should be a distinct and official function at the Research and Engineering Centers. Regardless of the character and duration of any flight program, plans and schedules should be drawn up, preferably by Flight Test Engineering, and approved by appropriate levels of management.
- b. There should be greater exchange of flight safety related information between the operations branches of the Centers. This could be a function of the ICOG, (2) above. An example, JSC has had several flameouts (some dual) in T-38 operations. Some weeks later DFRF which operates a T-38, had not heard of the problem, or its solution.
- c. Line management should be certain that flight safety issues are brought to their attention, and decisions thereon are not based on personalities. Example: The Flight Operations Chief at JSC had recommended a policy forbidding nonstop flights from the Cape to Ellington in T-38s. (Sound reasons: limited range, flameout problems, weather and congestion in the Houston area.) JSC management over-ruled, apparently influenced by the opinions of some of the astronauts.

Davis feels that flight operations at the Centers are in the hands of competent experienced managers. It is clear that the function of Flight Test Engineering with its planning and judgment inputs would enhance safety margins if the responsibility of assessing risks were assigned to such an organization by Flight Operations managers. Lee Davis specifically commends that suggestion of Williams to your attention. His overall attitude is that no apparent immediate hazards exist but inconsistencies from Base to Base and too-long familiarity with past practices suggest

that new emphasis from Headquarters is imperative along with sincere follow-up.

Very sincerely yours,

Willis M. Hawkins, Chairman
Aerospace Safety Advisory Panel