

Global Precipitation Measurement (GPM) Spacecraft Lithium Ion Battery Micro-Cycling Investigation

George Dakermanji, Leonine Lee, and Thomas Spitzer

George.dakermanji-1@nasa.gov, Leonine.lee@nasa.gov, Thomas. J. spitzer@nasa.gov

**Code 563, NASA Goddard Space Flight Center
Greenbelt, Maryland 20771**

- The Global Precipitation Measurement (GPM) is a Low Earth Orbit (LEO) spacecraft at 400 Km altitude and 65 degrees inclination. The spacecraft was launched from Tanegashima, Japan on February 27, 2014
- The GPM spacecraft has two instruments; the Dual-frequency Precipitation Radars (DPR) and the GPM Microwave Imager (GMI). The spacecraft development was funded jointly by the US and Japan. NASA/GSFC was responsible for the spacecraft, the GMI instrument, performed the I&T and is responsible for the Mission Operations from Goddard. JAXA built the DPR instrument, provided the launch vehicle and performed the launch services.
- The power system is a Direct Energy Transfer System (DET) designed to support 1950 Watts orbit average power.
- The GPM batteries were built by ABSL, U.S. in Longmont, Colorado and use SONY 18650HC cells. The spacecraft battery set consists of three 8s 84p batteries operated in parallel as a single battery.

Presented by Leonine Lee
2016 NASA Battery Workshop
November 15-17, 2016
Huntsville, AL

Beta = 0

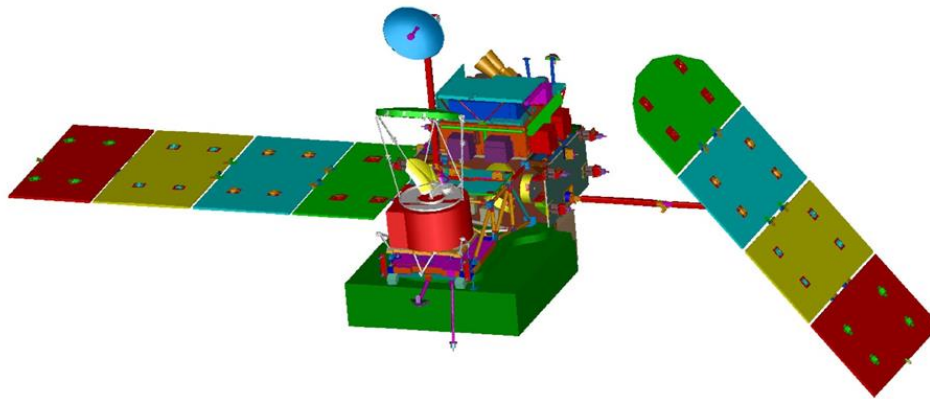

Beta = 90

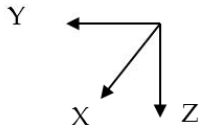

Eclipse Duration

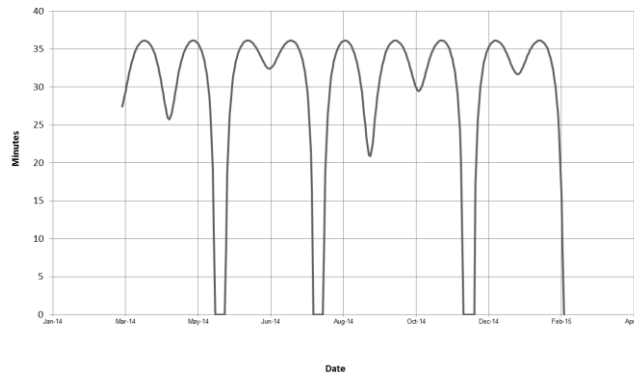

Presented by Leonine Lee
 2016 NASA Battery Workshop
 November 15-17, 2016
 Huntsville, AL

- During initial DPR Instrument integration with the spacecraft at GSFC, large current transients were observed in the battery.
- Investigation revealed that the DPR phased array radar generates cyclical high rate large current transients on the spacecraft power bus.
- The interaction of the DPR high current transients repeated at 700 milliseconds with the power system electronics operation lead to the battery transient current profile observed.
- The GPM solar array is divided into segments. The coarse solar array power control is performed by switching sequentially ON or OFF the solar array segments from the power bus depending on the loads and battery charge demand. The fine power control is performed by redundant Pulse Width Modulated (PWM) electronics of a solar array segment. A solar array segment is added or removed from the power bus when the PWM high or low limits are reached.

Strip Chart Recorder Battery Currents (40,000 points/second)

Current in each Battery at Beta =90°

Repetition rate of major waveform : Once/700 msec

'Heartbeat 'pulse rate about 75 Hz

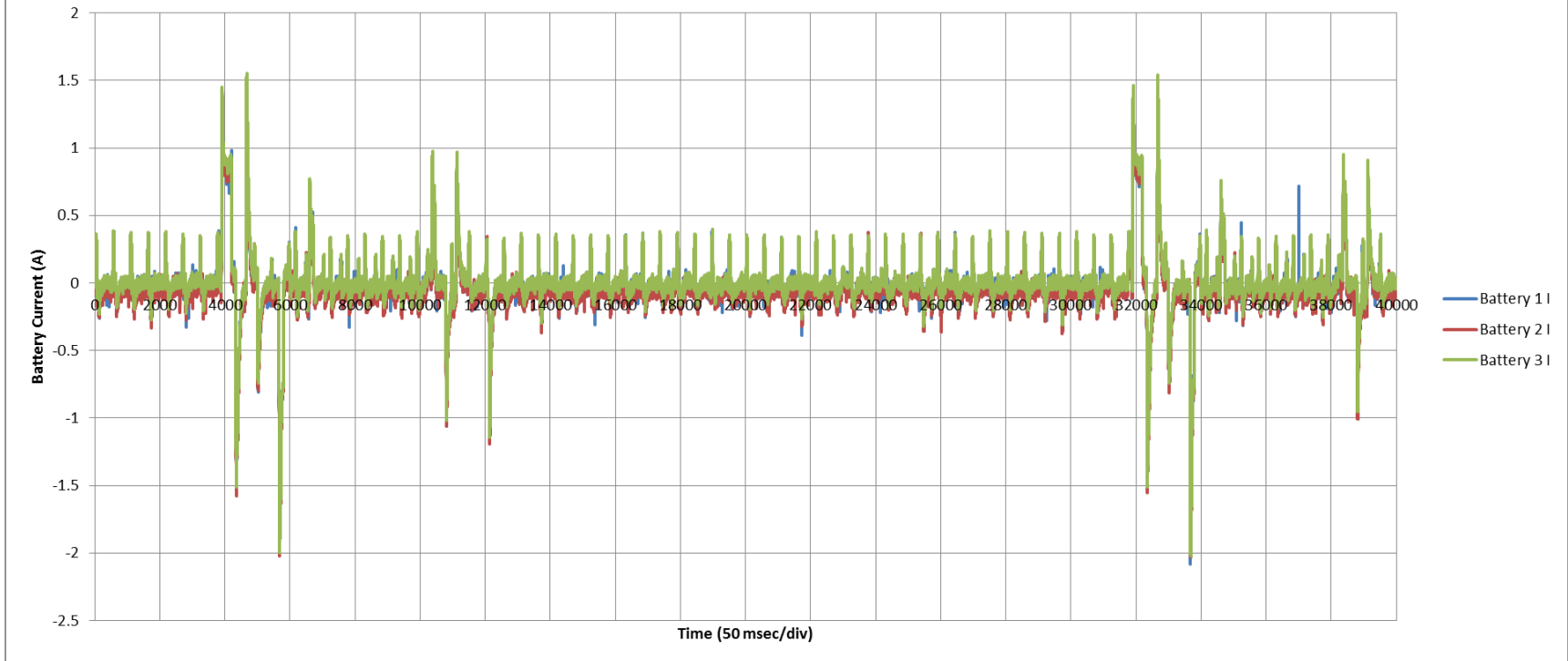

Presented by Leonine Lee
 2016 NASA Battery Workshop
 November 15-17, 2016
 Huntsville, AL

- During battery current charge and discharges at levels higher than the DPR transients, the DPR current transients in the battery were not of concern since their effect is basically to modulate the current in the charge or discharge periods. JPL test data on SONY 18650HC cell packs indicated negligible degradation (ref 1)
- However, during low current taper periods and during the full sun orbits, the DPR load transients will cause very large number of small charge/discharge cycling on the battery.
- No experimental data could be found on the effects of large number micro-cycling on battery life. Due to the timing of finding this issue, a quick resolution of potential impact on GPM was required. An accelerated test program was developed to bound the effect. Two batteries from a previous in-house GSFC spacecraft, the Lunar Reconnaissance Orbiter (LRO), were used that had batteries with the same number of series and parallel SONY 18650 HC cells.

- A conservative transient profile was selected for the stress test that enveloped the frequency and current amplitudes observed.
- A 100Hz, ± 2.5 A square wave current profile was selected
- The capacities of the Test and Control Batteries were characterized prior to test start .
- A test duration of 5 month was conservatively estimated to cover the predicted mission period were the micro-cycling is of concern.
- Tests were conducted with both batteries in ambient room temperature.
- The two batteries were charged to 33.1V (about 4.14 V/cell) corresponding to about 90% State-of-Charge (SOC) which was the SOC level planned for GPM orbital operations.

- A non-latching mercury relay is used to connect the battery to the electronic load and a wide bandwidth constant current power source .
- The electronic load is set to operate at 100Hz generating a 0 to 5A square wave load profile
- An Agilent Solar Array Simulator is used to generate approximately 2.5A constant current.
- The coil of the non-latching mercury relay are controlled through two series connected non-latching relays
- Independent primary and back-up protection circuits that monitor the battery voltage, current and temperature disable the drive to the mercury relay coil in case of overvoltage, overcurrent and over temperature.
- The battery current was monitored continuously with an oscilloscope . The solar array simulator current was adjusted when needed to maintain stable energy balanced operation in the battery

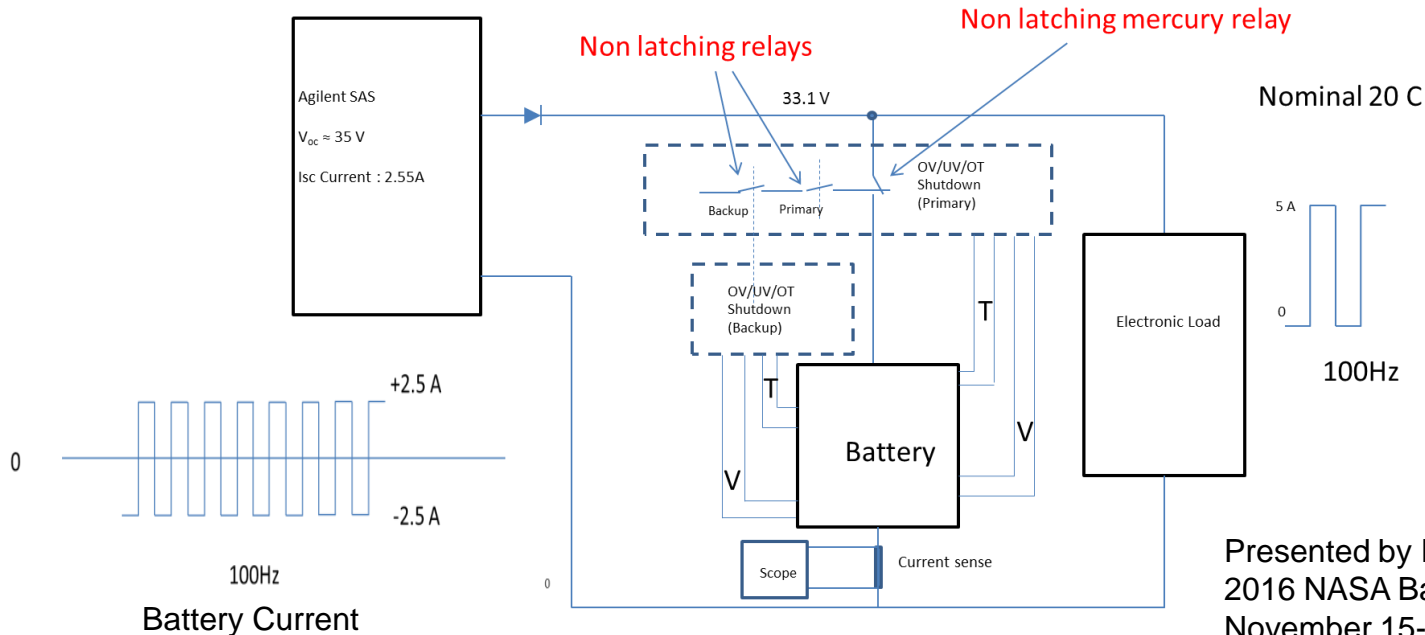

Presented by Leonine Lee
 2016 NASA Battery Workshop
 November 15-17, 2016
 Huntsville, AL

- The power supply was connected to the Control battery with a decoupling diode and a low current fuse
- The power supply current was limited to very low current of < 0.05 A and maximum voltage set ≈ 35 V

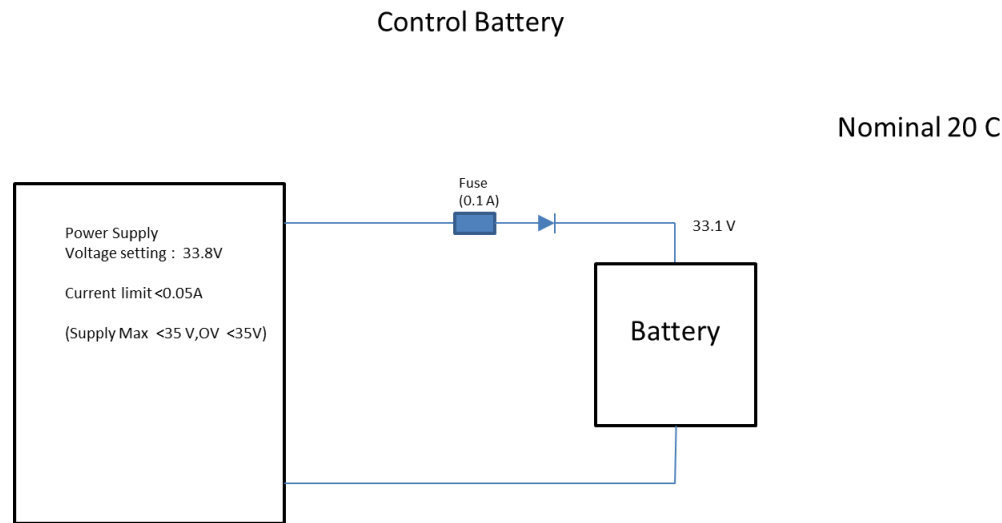

Presented by Leonine Lee
 2016 NASA Battery Workshop
 November 15-17, 2016
 Huntsville, AL

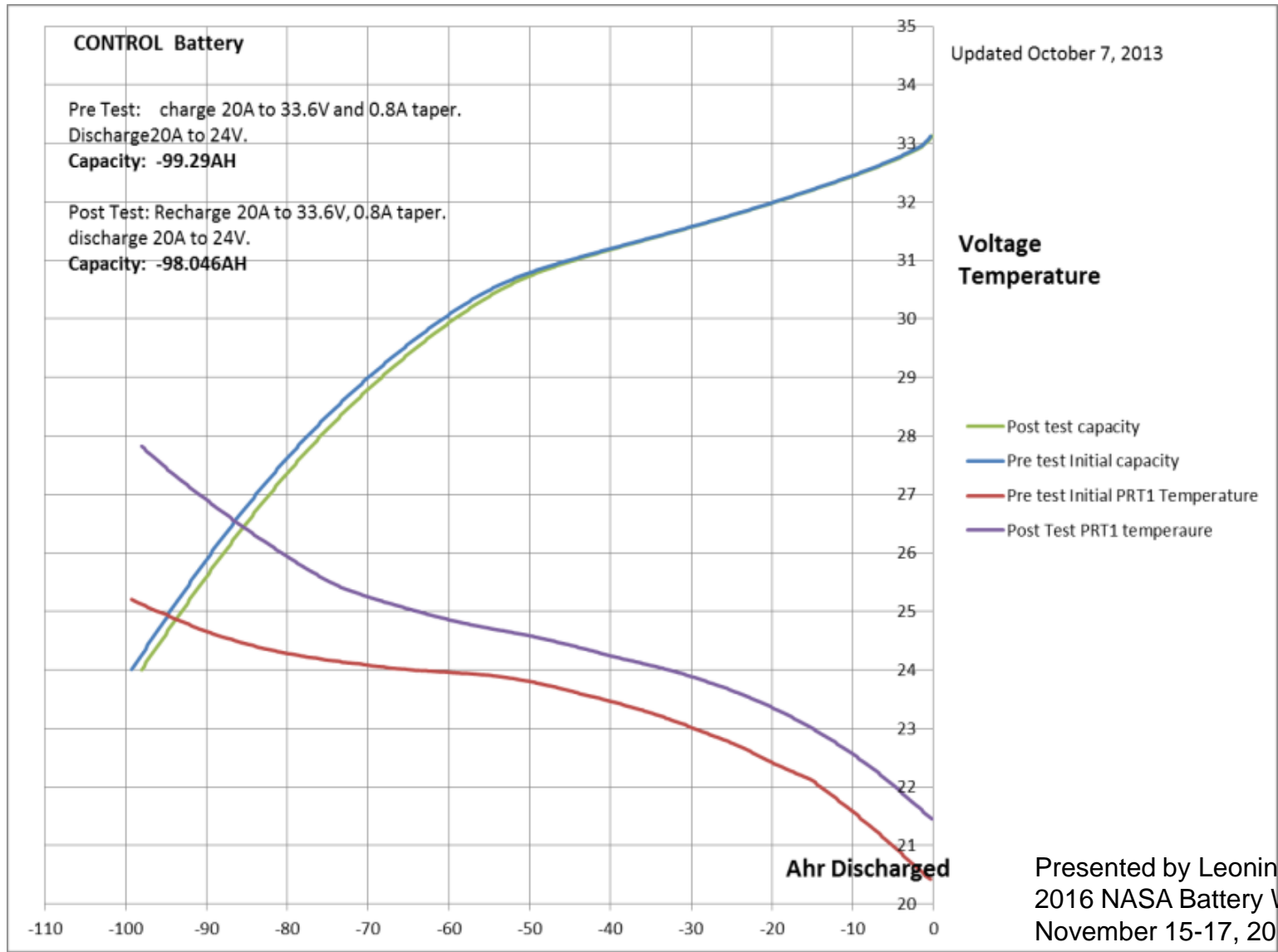

Presented by Leonine Lee
 2016 NASA Battery Workshop
 November 15-17, 2016
 Huntsville, AL

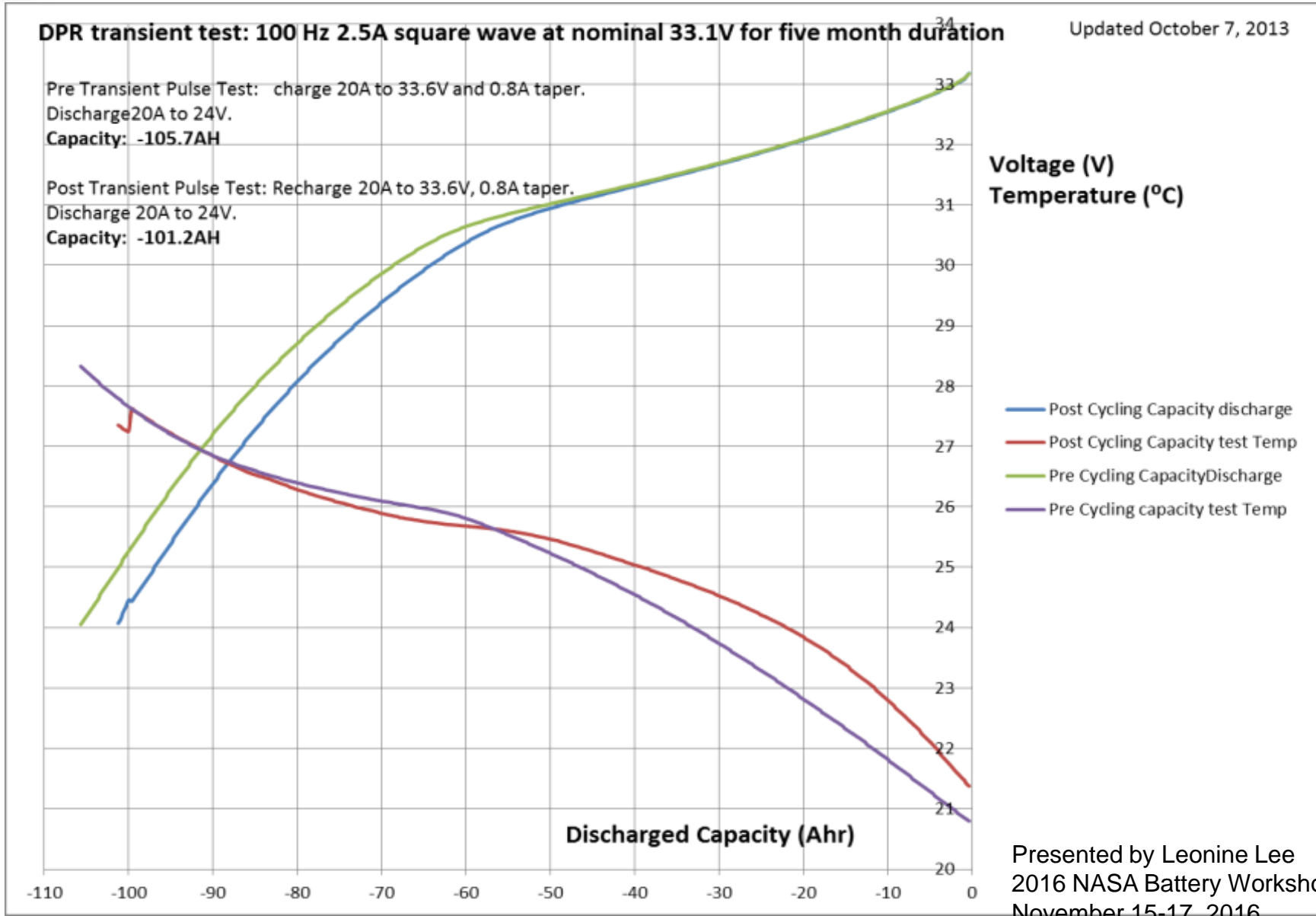

Presented by Leonine Lee
 2016 NASA Battery Workshop
 November 15-17, 2016
 Huntsville, AL

- The results indicate degradation of around 3.5% over the 5-month test period.
- Analysis of the worst case impact on GPM mission life was small indicating that the mission will not be compromised (three year mission with five year goal)
- The GPM battery sizing is conservative, with the actual loads less than the design, DOD around 10%. The capacity loss predicted with the very conservative worst case micro-cycling profile is relatively small.
- Note: A review of the history of the two Stress Test and Control Batteries indicated that the Test Battery had undergone no testing aside from the GSFC In-coming Capacity Tests after delivery from ABSL while the Control Battery was in use for a relatively short period. Since these small cell batteries do not undergo adequate formation cycles/burn-in, it is possible that the Test Battery degradation was partially due to its test history compared to the Control battery.

- To better characterize the capacity degradation with micro-cycling, a second test set up was developed and started using a more representative real-time current test profile using GPM I&T batteries that had undergone similar tests.
- Conservative transients simulation with more representative real time wave shape profile was selected

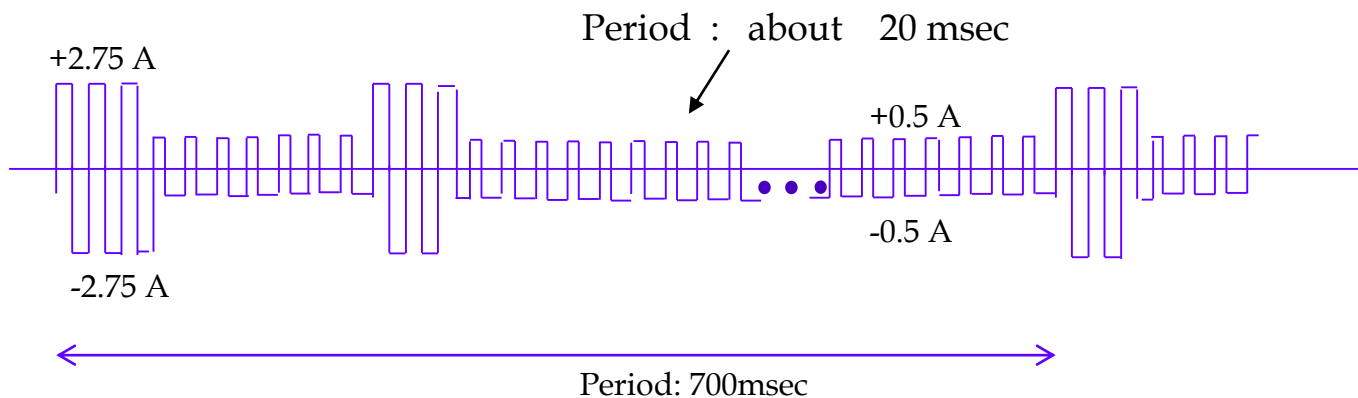

Presented by Leonine Lee
 2016 NASA Battery Workshop
 November 15-17, 2016
 Huntsville, AL

- An Agilent SAS Arbitrary Waveform Generator was used to generate the DPR transient wave-shapes.
- The batteries were on cooling plates and maintained at 20°C throughout the test period

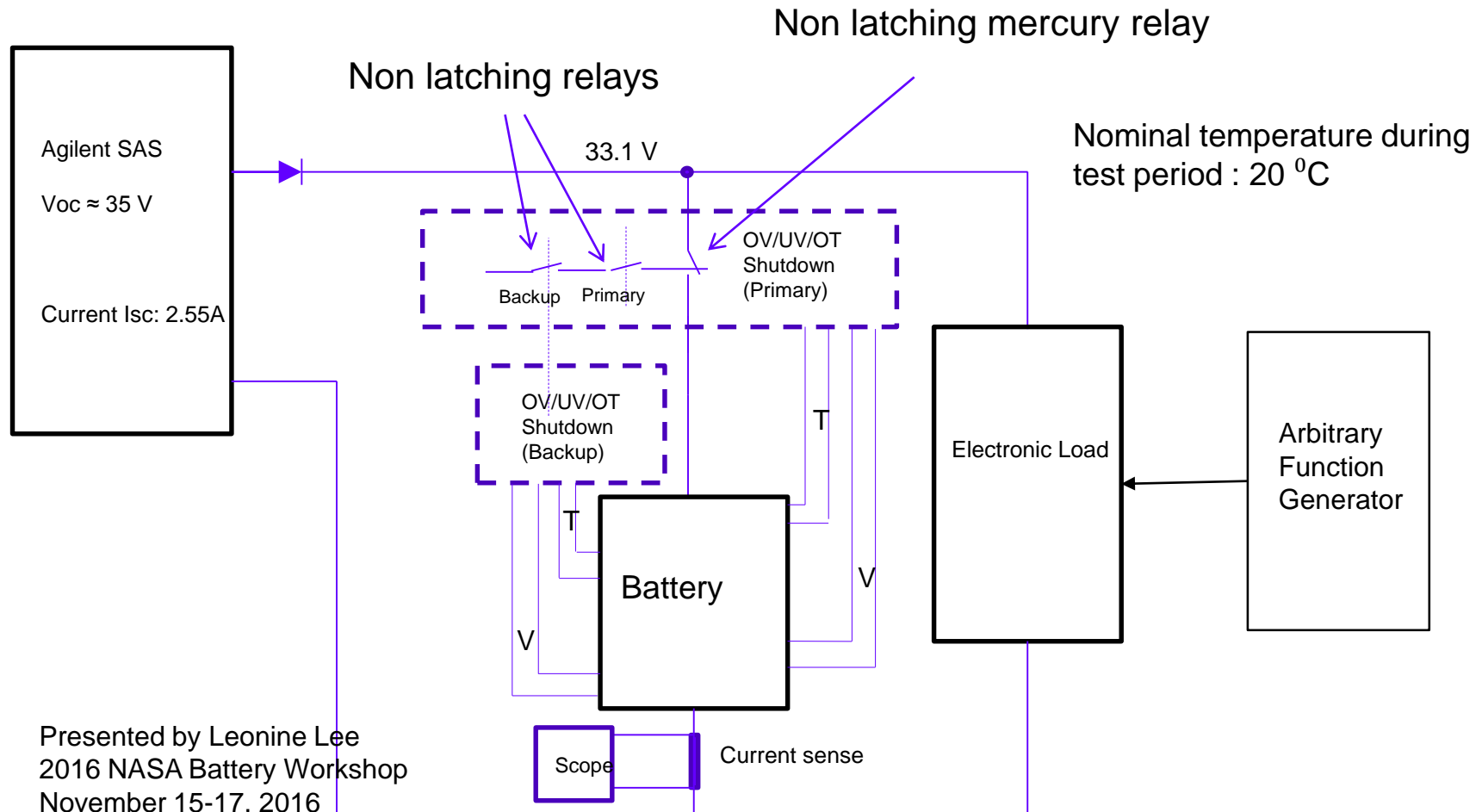

Presented by Leonine Lee
 2016 NASA Battery Workshop
 November 15-17, 2016
 Huntsville, AL

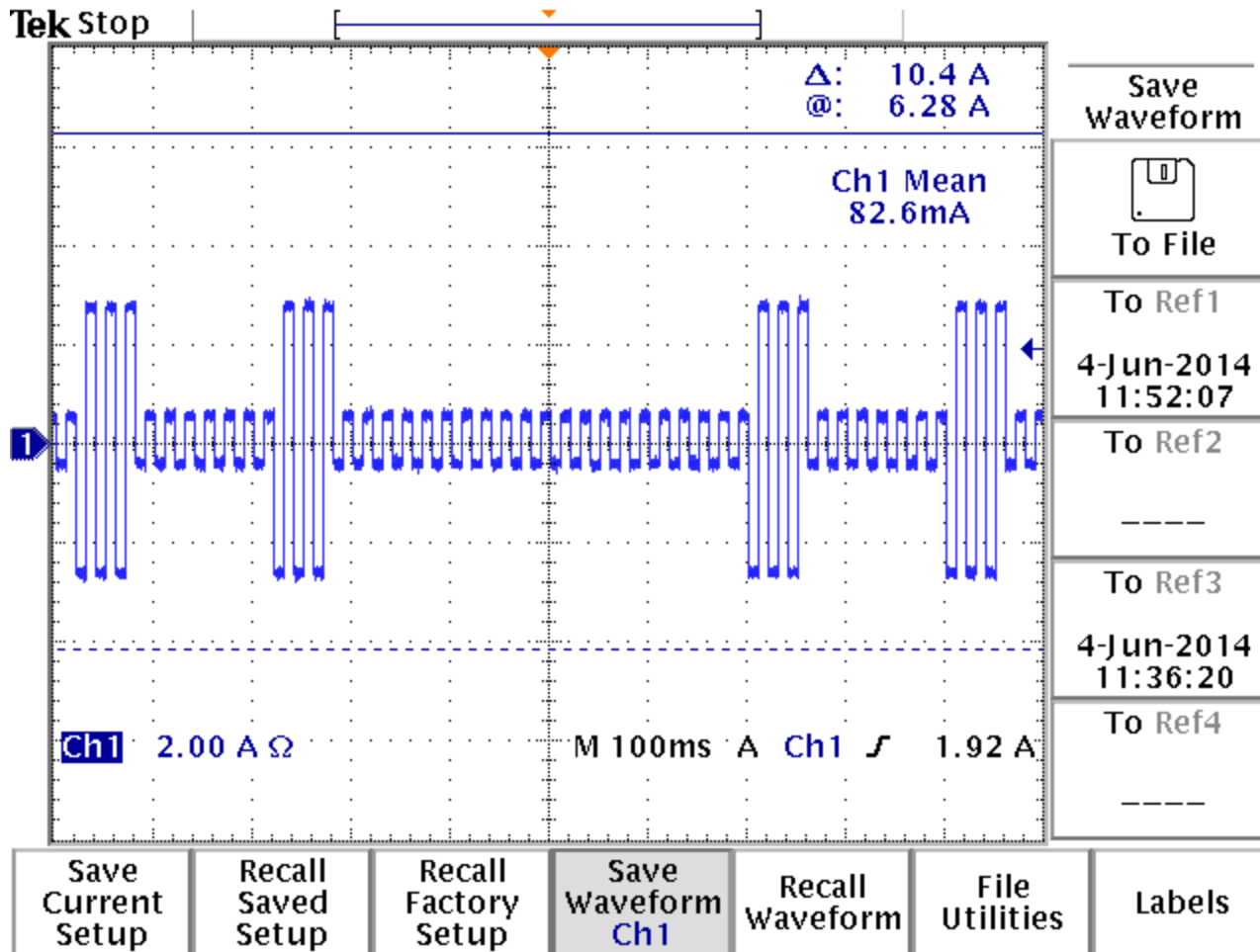

Presented by Leonine Lee
 2016 NASA Battery Workshop
 November 15-17, 2016
 Huntsville, AL

May 2014---August 2015 SN001,SN002 Capacity & Temperature Plots

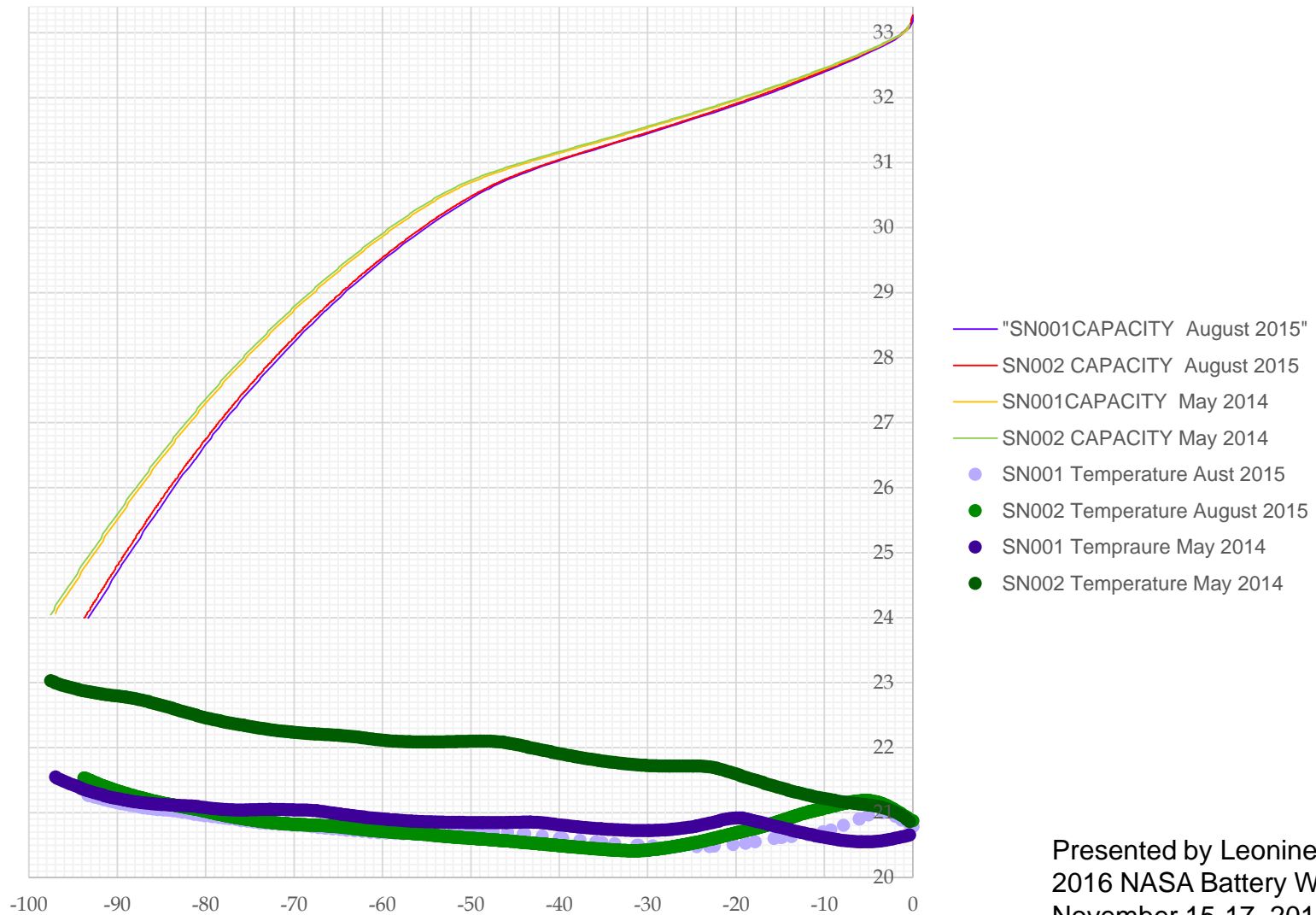

Presented by Leonine Lee
 2016 NASA Battery Workshop
 November 15-17, 2016
 Huntsville, AL

8/26/2015							
		Control Battery SN 001 Capacity (Ahr)	Test Battery with DPR equivalent Charge /discharge Transients SN002 Capacity (Ahr)			Divergence of CONTROL & TEST battery capacities	
Test Date							
Pre-test Capacity (1st test)	5/28/14	97.88			97.89		-0.01
Pre-test Capacity (2st test)	5/30/14	97.33			97.89		-0.56
August 2014 Intermedaite Capacity test	8/12/14	93.95			94.45		-0.5
October 2014 Intermediate Capacity Test	10/21/14	94.474			95.08		-0.606
January 2015 Intermediate Capacity Test	1/7/15	95.15			95.9		-0.75
August 2015 Intermediate Capacity Test	8/13/15	92.94			93.6		-0.66

Presented by Leonine Lee
 2016 NASA Battery Workshop
 November 15-17, 2016
 Huntsville, AL

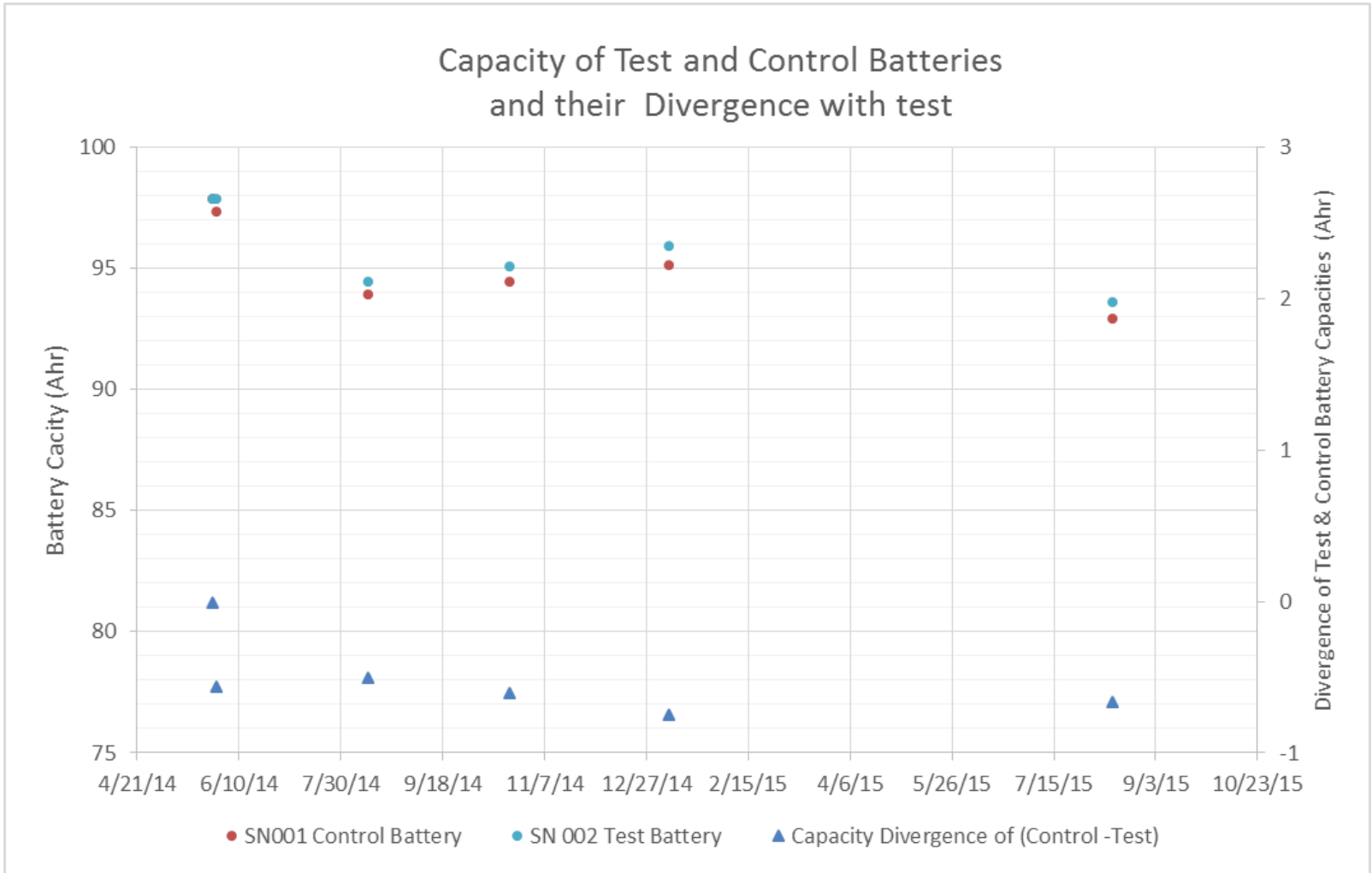

Presented by Leonine Lee
 2016 NASA Battery Workshop
 November 15-17, 2016
 Huntsville, AL

- The Real Time profile test results indicate minimal changes that can be attributed to micro-cycling
- The differences between the Test Battery capacity and Control Battery capacity test results are within measurement uncertainties

- The Stress Test was restarted using the GPM I&T batteries after completion of the Real Time test in August 2015 to verify the early test results, and to envelop worst case conditions for possible long duration multiple extension mission as is typical in GSFC missions. The TRMM satellite (about 400Km , 35°) that GPM satellite replaced operated for around 18 years and ended due to propulsion system fuel depletion.
- Same profile as first Stress Test: 100Hz generating a 0 to 5A square wave load profile

DPR Transients Tests: November 18 2015 and May 24 2016 Capacity Tests
 Sony 18650, 8s x 84p +/- 2.5 A , 100Hz

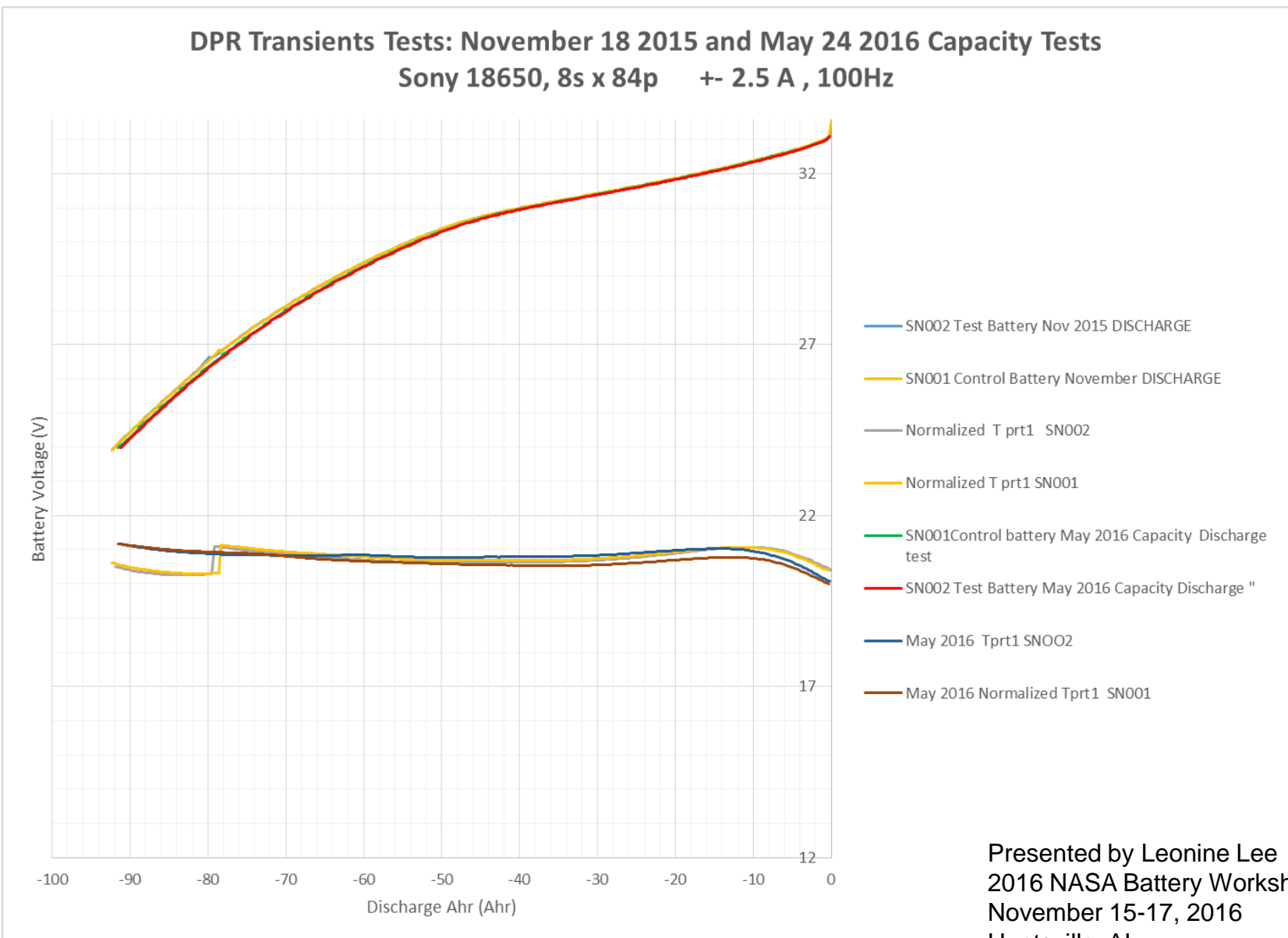

Presented by Leonine Lee
 2016 NASA Battery Workshop
 November 15-17, 2016
 Huntsville, AL

The Second Stress Life test on 84 p x 8s 18650HC batteries at ± 2.5 A and 100Hz the results indicate minimal differences between the Test Battery capacity and Control Battery capacity test results after 6-month of ± 2.5 A square wave 100Hz cycling. The differences are within measurement uncertainties



- Continue 100 Hz, +/- 2.5A cycling till November 2016.
- Modify the cycling profile and continue cycling

Presented by Leonine Lee
2016 NASA Battery Workshop
November 15-17, 2016
Huntsville, AL

1. Ratnakumar, Bugga et al; Safety Issues Related to Li-Ion Battery Testing Under LEO Cycling Coupled with Current Ripple. Space Power Workshop, April 18-21, 2011. Private discussions.
2. DPR Transient Currents Investigation, GPM internal report 10/25/2013

- *The authors would like to acknowledge the following staff in Code 563 at GSFC:*
 - Dong Sui and Tom Rozanski for helping in the testing.
 - Brad Kercheval and Steve Vincent for test setup design and waveform generator programming

- DET Direct Energy Transfer
- DOD Depth of Discharge
- DPR Dual-frequency Precipitation Radar
- GMI GPM Microwave Imager
- GPM Global Precipitation Measurement
- GSFC Goddard Space Flight Center
- I&T Integration and Test
- JAXA Japanese Aerospace Exploration Agency
- JPL Jet Propulsion Laboratory
- LEO Low Earth Orbit
- LRO Lunar Reconnaissance Orbiter
- NASA National Aeronautics and Space Administration
- PRT Platinum Resistance Thermometer
- PWM Pulse Width Modulated
- SOC State of Charge
- TRMM Tropical Rainfall Measuring Mission

Presented by Leonine Lee
2016 NASA Battery Workshop
November 15-17, 2016
Huntsville, AL