



**JHU/APL Work Performed Under Task: NNN13AA17T
NASA Contract NNN06AA01C**

Agency: National Aeronautics and Space Administration

Office: Radioisotope Power Systems Program Office

Location: Glenn Research Center

Nuclear Power Assessment Study Final Report

4 February 2015

Released on 1 June 2015

The Johns Hopkins University Applied Physics Laboratory
11100 Johns Hopkins Road
Laurel MD 20723

Prepared for:

June F. Zakrajsek
21000 Brookpark Road
Cleveland OH 44135
Phone: (216) 977-7470
E-mail: june.f.zakrajsek@nasa.gov

JHU/APL POCs:

Dr. Ralph L. McNutt, Jr. (Study Chair)
Mail Stop: 200-E258
Phone: (240) 228-5435
E-mail: ralph.mcnutt@jhuapl.edu

Dr. Paul H. Ostdiek (Program Manager)
Mail Stop: 200-E520
Phone: (240) 228-8698
E-mail: paul.ostdiek@jhuapl.edu

This technical study was intended to identify strategies and issues to the provisioning of safe, reliable and affordable nuclear power systems for potential consideration by NASA's Science Mission Directorate. It is not intended to represent NASA policy or planning.

NUCLEAR POWER ASSESSMENT STUDY



Final Report

Radioisotope Power Systems Program

TABLE OF CONTENTS

TABLE OF CONTENTS	1
EXECUTIVE SUMMARY	1
NASA Nuclear Power Requirements	6
Sustainability	7
Fission Power System Possibilities for SMD.....	8
Technical	8
Fuel availability	8
Fuel and security costs of FPS versus RPS	9
Flight FPS costs remain unknown	9
PREFACE	11
ACKNOWLEDGMENTS	14
1 INTRODUCTION	15
1.1 Study Objectives and Terms of Reference.....	15
1.2 Study Organization	15
1.3 Study Methodology	16
2 DESIGN REFERENCE MISSIONS	17
2.1 Mission Study Goals and Methodology.....	17
2.1.1 DRM Selection Overview	18
2.1.2 Decadal Survey TSSM Concept Overview	18
2.1.3 Decadal Survey UOP Concept Overview.....	20
2.1.4 DRM Ground Rules	21
2.2 NPAS DRM Results.....	22
2.2.1 Summary.....	22
2.2.2 NPAS TSSM RPS Study Results.....	22
2.2.2.1 NPAS TSSM RPS Study Ground Rules and Method	22
2.2.2.2 NPAS TSSM RPS Study – Questions Answered	23
2.2.2.3 NPAS TSSM RPS Study Options Summary.....	23
2.2.3 NPAS UOP RPS Study Results	23
2.2.3.1 NPAS UOP RPS Study Approach, Challenges, Constraints, and Assumptions	24
2.2.3.2 NPAS UOP RPS Study - Questions Answered.....	25
2.2.3.3 2014 UOP Replacement Options Summary.....	25
2.2.4 NPAS TSSM FPS Study Results	26
2.2.4.1 NPAS TSSM FPS Study Approach, Ground Rules and Assumptions.....	27
2.2.4.2 Mission Accommodations	29
2.2.4.3 NPAS TSSM FPS Study – Questions Answered.....	29
2.2.4.4 NPAS TSSM FPS Study Options Summary	30
2.2.5 NPAS UOP FPS Study Results.....	31
2.2.5.1 NPAS UOP FPS Study Approach, Constraints, and Assumptions.....	31
2.2.5.2 NPAS UOP FPS Study Summary.....	32
2.2.6 Mission Opportunities with Higher Power	32
2.3 Assembly, Test, and Launch Operations (ATLO) for Nuclear-enabled Missions at Kennedy Space Center: RPS and FPS.....	33
2.3.1 Summary.....	33
2.3.2 Nuclear Mission ATLO Team’s Objectives.....	33
2.3.3 ATLO Assessment Development Process	34
2.3.4 ATLO Assessment Approach	34
2.3.5 New RPS Assessment.....	34

2.3.5.1	Radioisotope Thermoelectric Generators	34
2.3.5.2	Stirling Radioisotope Generator Systems.....	35
2.3.6	FPS Assessment.....	36
2.3.6.1	Compare or Contrast with Existing RPS Experience	36
2.3.6.2	Security Considerations	36
2.3.6.3	Operations Analysis	37
2.4	Instrument Sensitivity Analysis	39
2.4.1	Summary.....	39
2.4.2	Objectives, Approaches, and Assumptions	39
2.4.3	Reference Radioisotope Systems.....	40
2.4.4	Impact of RPS Implementations on TSSM and UOP Payloads.....	40
2.4.5	Reference Fission Systems	40
2.4.6	Impact of FPS Implementations on TSSM and UOP Payloads.....	41
2.4.6.1	NPAS TSSM Study	41
2.4.6.2	NPAS UOP Study	42
2.4.7	Environmental Impact of Nuclear Power System Implementations on Payloads and Mitigation Strategies	42
2.4.7.1	Radiation.....	42
2.4.7.2	Thermal.....	43
2.4.7.3	Vibration	44
2.4.7.4	Pointing and Fields of View.....	44
2.4.7.5	Electromagnetic Interference (EMI).....	44
2.4.7.6	Magnetic Fields.....	45
2.5	Power Needs Assessment for NASA Missions	45
2.5.1	Summary.....	45
2.5.2	Objectives and Approaches.....	45
2.5.3	HEOMD Missions	46
2.5.4	SMD Science Missions.....	46
2.6	Transition Point between RPS and FPS for Science Missions.....	48
2.6.1	Summary.....	48
2.6.2	Objectives	48
2.6.3	Estimate of Potential Total Power Available from Plutonium.....	48
2.6.4	Transition Point Analysis – Plutonium Fuel Availability	49
2.6.5	Transition Point Analysis – Mass	49
2.6.6	Transition Point Analysis – Cost.....	50
2.7	Mission Study Summary	51
3 	DESIGN REFERENCE SYSTEMS	52
3.1	System Study Team Methodology	52
3.2	Parametric Systems Analysis.....	53
3.3	Radioisotope Power Systems: State-of-the-Art.....	57
3.3.1	Radioisotope Thermoelectric Generators (RTGs)	57
3.3.2	Stirling Radioisotope Generators (SRGs).....	57
3.3.3	Roadmap for Developing New RPS Technology.....	57
3.4	Design Reference Radioisotope Power Systems	58
3.4.1	Advanced Radioisotope Thermoelectric Generators.....	58
3.4.1.1	Modular ARTG concept.....	62
3.4.1.2	Thermoelectric Extensibility to FPS.....	63
3.4.1.3	ARTG Observations	65
3.4.1.4	Possible Near-term ARTG Forward Work	65

3.4.2	Stirling Radioisotope Generators.....	66
3.4.2.1	Common Convertor SRG Concept	68
3.4.2.2	Proposed Design Improvements in the next SRG	70
3.4.2.3	Stirling Extensibility to FPS	72
3.4.2.4	SRG Observations.....	73
3.4.2.5	Possible Near-term SRG Forward Work.....	75
3.5	Design Reference Fission Power Systems.....	75
3.5.1	Fuel Assessment	78
3.5.2	Reactor Description	78
3.5.3	Radiation Shield Description	80
3.5.4	FPS Reactor Scalability	80
3.5.5	Alternative FPS Concepts.....	83
3.5.6	FPS Observations.....	83
3.5.7	Possible Near-term FPS Forward Work.....	84
3.6	Infrastructure and Fuel Availability	85
3.6.1	RPS DOE Infrastructure [124,125]	85
3.6.2	Plutonium-238 Fuel Production.....	90
3.6.3	Potential for Increasing Pu-238 Production Rate	92
3.6.4	Impact of Pu-238 on Mission Power	93
3.6.5	HEU Availability and Observations	94
3.6.6	FPS Ground Testing Facilities	95
4	 SAFETY, ENVIRONMENTAL PROTECTION, LAUNCH APPROVAL, AND SECURITY	97
4.1	U.S. Space Nuclear Systems – The Safety Challenge	97
4.1.1	Introduction	97
4.1.2	Background History	97
4.1.3	The Foundations of U.S. Space Nuclear Power Safety	100
4.1.3.1	Purpose, Objectives & Strategy of Safety.....	100
4.1.3.2	Building Safety into the Design of U.S. Space Nuclear Systems.....	100
4.2	Assessing the Environmental Impact, Safety, & Risk Associated with the Development & Use of Space Nuclear Systems.....	101
4.2.1	NEPA Compliance Process	101
4.2.1.1	Specific NEPA Considerations for any Potential Future FPS Development	102
4.2.2	US Safety Analysis, Review, and Launch Approval Process.....	104
4.2.2.1	The Launch Approval Process.....	104
4.2.2.2	Elements of the Risk Assessment	106
4.2.2.3	Safety Analysis Computational Overview	107
4.3	Security for a Fission Power System.....	111
4.3.1	Introduction	111
4.3.2	Security Summary.....	111
4.4	Summary of Schedule and Cost Impacts for New RPS	113
4.5	Summary of Schedule and Cost Impacts for New FPS	113
4.5.1	Schedule Impacts	113
4.5.2	Cost Impacts.....	114
5	 ROUGH ORDER-OF-MAGNITUDE (ROM) COSTS.....	115
5.1	RPS Design, Development, Test and Engineering Assumptions	115
5.1.1	Modular Advanced Radioisotope Thermoelectric Generator Development.....	115
5.1.2	Stirling Development.....	116
5.2	Fission Power System Design, Development, Test and Engineering Key Assumptions.....	117
5.2.1	FPS Development.....	118

5.3	System Study Team Cost Elements by Phase	119
5.4	System Design, Development, Test and Engineering Cost Summary	120
5.5	ROM Mission Cost	123
5.5.1.1	Design Reference Mission ROM Cost Generation Approach – Mission Concepts	123
5.5.2	Non-Nuclear Mission Cost Analysis Findings.....	124
5.5.2.1	UOP 2014 RPS Study.....	125
5.5.2.2	TSSM 2014 RPS Study	126
5.5.2.3	TSSM 2014 FPS Study	129
5.5.3	Nuclear Mission Power System and Launch ROM Cost Generation Approach	130
5.5.3.1	Descriptions and Assumptions for Nuclear Mission Cost Items	130
5.5.3.2	TSSM 2014 RPS and FPS Study – Nuclear Mission Launch Cost Analysis Findings	137
5.5.4	Total Mission Cost Analysis Findings for 2014 TSSM Study.....	137
5.6	NPS Non-Mission/Non-System Costs.....	137
5.6.1	RPS and FPS Skills and Capabilities Sustainment	138
5.6.2	RPS Infrastructure Sustainment	139
5.6.3	FPS Infrastructure Sustainment	139
6 	FINDINGS	140
6.1	Background to Findings.....	140
6.2	Findings	140
6.2.1	Technical Findings	140
6.2.1.1	RPS specific.....	142
6.2.1.2	FPS specific.....	143
6.2.2	Sustainability Findings	145
6.2.3	General Observations.....	146
6.3	Take Away from the NPAS Effort.....	147
	APPENDIX A: NUCLEAR POWER ASSESSMENT STUDY TERMS OF REFERENCE (TOR)	148
	APPENDIX B: STUDY PARTICIPANTS*	153
	APPENDIX C: ACRONYMS.....	156
	APPENDIX D: KEY DATES	163
	APPENDIX E: INVENTORY ALLOCATION OF PLUTONIUM-238 FOR CIVIL SPACE APPLICATIONS.....	164
	REFERENCES	167

List of Figures

Figure 2-1 | Decadal Survey TSSM Conceptual Flight System 19

Figure 2-2 | Decadal Survey UOP Conceptual Spacecraft Layout 20

Figure 2-3 | NPAS TSSM 1kW_e FPS Spacecraft Configuration 28

Figure 2-4 | ATLO Assessment Process 34

Figure 2-5 | Summary of ALTO Scenario Option 1 38

Figure 2-6 | Summary of ATLO Scenario Option 6 38

Figure 2-7 | Neutron Dose Over 15 Years, Out to 1,000 cm 41

Figure 2-8 | Gamma Dose Over 15 Years, Out to 1,000 cm 41

Figure 2-9 | NPAS TSSM Study Notional FPS Spacecraft Layout 42

Figure 2-10 | Representative Power Ranges for SMD Mission Class 47

Figure 2-11 | NPAS RPS and FPS Mass v.s. EOM Power 50

Figure 2-12 | Nuclear Power Cost v.s. EOM Power for NPAS Concepts 51

Figure 3-1 | ARTG 500 W_e-Class Concept with Segmented TE Couples 60

Figure 3-2 | ARTG Electrical Power Output and Specific Power Performance Predictions 61

Figure 3-3 | MOD-ARTG Configurations Based on a 4-GPHS Stackable Segment 62

Figure 3-4 | Electrical Power Output and specific Power of Mod-ARTG Configurations 63

Figure 3-5 | Common Building Block Segmented Thermoelectric Module for ARTG and 1 kW_e TE FPS 64

Figure 3-6 | Thermoelectric Technology Roadmap 66

Figure 3-7 | ASRG Engineering Unit 2 67

Figure 3-8 | Potential Generator Configurations Using a Common Stirling Converter 70

Figure 3-9 | Alternative Stirling Control Architecture 72

Figure 3-10 | Stirling Extensibility to FPS 74

Figure 3-11 | Reactor Design from the Decadal NASA/DOE Study 76

Figure 3-12 | 1-kW_e TE FPS from the Decadal NASA/DOE Study 77

Figure 3-13 | 3-kW_e Stirling FPS From the Decadal NASA/DOE Study 77

Figure 3-14 | 1-kW_e Stirling FPS Concept 78

Figure 3-15 | NPAS FPS Reactor Configuration 79

Figure 3-16 | NPAS FPS Shield Configuration 80

Figure 3-17 | NPAS FPS Reactor Cross-Sections for Four Thermal Power Levels 81

Figure 3-18 | Projected Shield Mass as a Function of Thermal Power and Dose 82

Figure 3-19 | STMD KiloPower Technology Development Project 84

Figure 3-20 | General Purpose Heat Source Module 86

Figure 3-21 | DOE Role in NASA Nuclear Launches 86

Figure 3-22 | Light Weight Radioisotope Heater Unit 87

Figure 3-23 | Aqueous Processing Glovebox Line at LANL 87

Figure 3-24 | IAAC at INL’s Space and Security Power Systems Facility 88

Figure 3-25 | MMRTG Being Assembled in IAAC 89

Figure 3-26 | Thermal Vacuum Chamber at INL’s Space and Security Power Systems Facility 89

Figure 3-27 | 9904 RPS Shipping Cask in Radioisotope Thermoelectric Generator Facility at KSC 89

Figure 3-28 | Impact of Pu-238 Production on Mission Power 94

Figure 3-29 | Device Assembly Facility at NNS 96

Figure 4-1 | The U.S. Safety Review & Launch Approval Process for Nuclear-Powered Space Missions 105

Figure 4-2 | Computational Flow for the Launch Approval Safety Analysis 108

Figure 5-1 | 16-GPHS ARTG Notional Development Schedule 116

Figure 5-2 | 6-GPHS SRG Notional Development Schedules 117

Figure 5-3 | 1-kW_e FPS Notional Development Plan 119

Figure 5-4 | NPAS Concept System Technology, Engineering, & Flight System Development Costs, Graphical Survey 121

List of Tables

Table ES-1 | Planetary Decadal Survey RPS Needs [24] 2

Table ES-2 | Characteristics of Funded DSCME Studies..... 6

Table 2-1 | NPAS DRM Selection Criteria 18

Table 2-2 | TSSM Mission Concept Parameters..... 17

Table 2-3 | Decadal Survey UOP Conceptual Orbiter Key Parameters 21

Table 2-4 | NPAS TSSM 1kW_e RPS Study Options Summary 24

Table 2-5 | NPAS UOP RPS Replacement Options Summary 26

Table 2-6 | Comparison of the Decadal Survey TSSM Study and FPS Concepts..... 30

Table 2-7 | Thermal Waste Heat from the NPAS Power Systems [Total Heat/Waste Heat]..... 44

Table 2-8 | Specific Power for Existing RPS and NPAS RPS and FPS Concepts..... 50

Table 3-1 | ARTG Parametric Option Set 54

Table 3-2 | SRG Parametric Option Set..... 55

Table 3-3 | NPAS FPS Parametric Option Set..... 56

Table 3-4 | Key Assumptions for NPAS ARTG Conceptual Design Study..... 59

Table 3-5 | 8-Couple TE Module Characteristics for the MOD-ARTG and 1 kW_e TE FPS Concepts..... 64

Table 3-6 | Available Stirling Convertor Options..... 68

Table 3-7 | REactor Performance Data for Four Thermal Power Levels..... 81

Table 3-8 | 16-GPHS ARTG Availability based on Pu-238 Production Rate Variations 91

Table 3-9 | 6-GPHS SRG Availability Based on PU-238 Production Rate Variations 92

Table 4-1 | Space Nuclear Systems Launched by the U.S. (1961-2014)..... 98

Table 5-1 | Reference System Cost Elements By Phase 120

Table 5-2 | Design, Development, Test and Engineering Cost Summary 121

Table 5-3 | Summary of Non-Nuclear Mission Costs (FY15 \$) 124

Table 5-4 | 2014 NPAS UOP RPS Mission Non-Nuclear Related Cost Breakdown Comparison (\$M) 125

Table 5-5 | 2014 NPAS UOP RPS WBS 6.0 Spacecraft Non-Nuclear Cost Breakdown Comparison (\$M) 126

Table 5-6 | 2014 NPAS TSSM RPS Mission Non-Nuclear-Related Cost Comparison (\$M) 127

Table 5-7 | 2014 NPAS TSSM WBS 6.0 Spacecraft Non-Nuclear Cost Comparison (\$M) 128

Table 5-8 | 2014 NPAS TSSM 1 kW_e FPS Mission Non-Nuclear Cost Breakdown Comparison (\$M) 129

Table 5-9 | Nuclear Mission Cost Items 131

Table 5-10 | TSSM 2014 Study—Preliminary Nuclear Mission Launch Cost Analysis Findings (\$M) 137

Table 5-11 | 2014 NPAS TSSM Study—Preliminary Nuclear Mission Cost Analysis Findings** (\$M) 138

Table 5-12 | Recurring DOE Funding for Sustainment..... 139

Table 5-13 | Non-Recurring DOE Funding for Sustainment..... 139

EXECUTIVE SUMMARY

The objective of this study¹ is to "Discuss a sustainable strategy and present findings for the provisioning of safe, reliable, and affordable nuclear power systems that enable NASA Science Mission Directorate (SMD) missions and is extensible to Human Exploration and Operations Mission Directorate (HEOMD) needs in the next 20 years."

The context of this study is set by the confluence of ongoing requirements and continuing budget pressures. Stated in the "Background" of the "Terms of Reference" for this study (Appendix A):

NASA has pursued different approaches for provisioning nuclear power systems. In recent history, Radioisotope Power Systems (RPS) have been provisioned in support of the Science Mission Directorate (SMD) for robotic exploration. Fission Power Systems (FPS) have been in development in support of Human Exploration and Operations Mission Directorate (HEOMD) goals. Nevertheless, fission and radioisotope power systems have traveled down parallel development paths, requiring separate resources. SMD is considering the possibility of using both RPS and FPS for future missions. This potential approach along with the current budget scenario presents an opportunity to explore development of common power system technologies that feed both FPS and RPS as an alternate provisioning strategy. This strategy may hold the possibility of furthering exploration goals for several mission directorates, while reducing technology risk associated with new systems development.

NASA's need for RPS to enable robotic scientific missions for planetary exploration has been a "given" for over 4 decades. The continuing need for planetary missions has been articulated clearly during the last decade from the NRC report of 2009 [1] through the Planetary Decadal Survey of 2011, "Vision and Voyages" [2] (Table ES-1). Requirements across the other Divisions within the Science Mission Directorate and across other Directorates have not been as clear.² Implementation of these systems has never been an easy task. An ongoing difficulty is the inherent difference between the development cycle of RPS and the shorter time from mission approval to launch. Joining these two different sets of requirements—and their associated different ways of "doing business"—remains a challenge in the partnership between DOE and NASA to develop and fly these power systems.

¹ The study objective is found in the "Terms of Reference" for this study and reproduced in its entirety in Appendix A.

² The only other explicit heliosphere mention has been in the Heliophysics Decadal Survey, which notes that RPS are required for implementing future, but currently notional, missions to the outer and beyond [3].

TABLE ES-1 | PLANETARY DECADAL SURVEY RPS NEEDS [2]

Mission Concept*	Class†	Nuclear ¹ (Y)	Cost [§] (FY \$15 B)	Power System Type¶	#ASRG**	# MMRTG‡	Pu-238†† (kg)	BOM Power ^{§§} (We)	\$M/We BOM¶¶
LGN	NFC	Y	1.317	A	4	0	3.5	576	2.29
CSSR	NFC		1.483	S	0	0	0	500	2.97
MAX-C	FC		3.498	S	0	0	0	677	5.17
MAX-C descope	FR		2.441	S	0	0	0		
MSR Lander/MAV	FC		3.998	S	0	0	0	714	5.60
MSR Orbiter/EEV	FC		1.580	S	0	0	0	634	2.49
JEO	FR (AB)	Y	4.668	M	0	5	17.6	625	7.47
TSSM	FC	Y	6.712	M+A	5	1	7.9	600	11.19
VCM	FC		2.415	S+B	0	0	0	854	2.83
SP	NFC	Y	1.297	A	2	0	1.8	280	4.63
UOP no SEP	FR	Y	2.728	A	3	0	2.6		
UOP w/SEP	FC	Y	3.382	A	3	0	2.6	438	7.72
Trojan Tour	NFC	Y	1.303	A	2	0	1.8	280	4.65
Enceladus Orbiter	FC	Y	1.879	A	3	0	2.6	480	3.91
Io Orbiter	NFC	Y	1.383	A	2	0	1.8	320	4.32
Totals (no descope)			34.913		19	6	37.8	6,978	5.00
Totals (descope)			33.203		19	6	37.8		
Totals (no descope) – nuclear only			21.940					3,599	6.10
Totals (no descope) – non-nuclear only			12.974					3,379	3.84

*Mission Concepts: LGN – Lunar Geophysical Network (4 landers total); CSSR – Comet Surface Sample Return; MAX-C – Mars Astrobiology Explorer-Cacher; MSR – Mars Sample Return; MAV – Mars Ascent Vehicle; EEV – Earth Entry Vehicle; JEO – Jupiter Europa Orbiter; TSSM – Titan Saturn System Mission; VCM – Venus Climate Mission; SP – Saturn Probe; UOP – Uranus Orbiter and Probe

Nuclear¹: Y = nuclear (here RPS); no entry means solar arrays and/or batteries

†Class: NFC – New Frontiers Candidate; FC – Flagship Candidate; FR – Flagship Recommendation; FR (AB) – Flagship Recommendation under Augmented Budget

§Cost (Total Mission Cost with all threats; CATE estimate by the Aerospace Corporation in fixed FY\$15 B)

¶System (Assumed power system for technical and CATE studies): S – solar arrays; A – ASRG; M – MMRTG; B – batteries as prime (on probes)

**Number of ASRGs assumed

‡Number of MMRTGs assumed

**Approximate mass of Pu-238 isotope required (kg, rounded to nearest 0.1 kg) at nominal fueling levels: assumes 110g of isotope per FC, 8 FC’s per ASRG (2 GPHS Step 2 modules), and 32 FCs per MMRTG (8 GPHS Step 2 modules)

§§Power – Nominal required BOM power in We (does not include power for SEP stage for CSSR). The most stressing case is given if multiple flight elements are used; hence, the power number is more representative for some missions, e.g., 714 We is the most stressing case during EDL for the lander for the MSR Lander/MAV entry.

¶¶ \$/ We – Specific mission concept cost expressed as fixed year FY15 M\$ per BOM We; ratio of values in column 3 to those in column 8

The following issues were provided for the NPAS team to consider:

- (1) There are well known benefits of more efficient power systems.

- (2) NASA's PSD wants to understand the potential for commonality between Planetary RPS systems and components and any initial future investments in fission systems and components to guide its technology investments.
- (3) Identification of opportunities and challenges of a sustainable, incremental development strategy for Nuclear Power Systems (NPS) are needed to support the efficient development of technology requirements both for SMD needs and future fission capabilities for HEOMD.

The first item is driven by the ever-present need in space to minimize mass, which must be delivered with expensive launch vehicles. While access to space has improved since the early years of the space era, its expense remains a challenge both to power supply systems, such as RPS, and power usage systems, such as the spacecraft systems and scientific instruments of the payload. Hence, one must consider the mass trades between various RPS and Fission Power Systems (FPS) as they affect mass overall. In addition, the supply of Pu-238 for RPS is both expensive and scarce, so its efficient use and stewardship remain central challenges for NASA and DOE.

Human missions to deep-space locations such as extended missions on the lunar and Martian surfaces have always been recognized as requiring some form of nuclear power. The short-term nature of the Apollo missions to the Moon allowed for the use of batteries and fuel cells, although the long-lived experiments within the five deployed³ Apollo Lunar Surface Experiment Packages (ALSEP) made use of one RPS each [4]. Although there is an inherent difference in scale between robotic and human missions, the costs of the associated power supplies and converter technologies (converting the thermal energy generated from nuclear heat sources to electricity) are of a sufficient magnitude that it is important to identify any common requirements across the Agency that may exist, both for the Agency as a whole and for easing the investment requirements of the PSD via cost sharing that makes sense.

Recent HEOMD studies have validated Mars surface power needs at 35 to 40 kW_e, which could possibly be provided by a single, full-size power unit or multiple smaller power units in the ~10s of kW_e range, levels not practicable with RPS. Nonetheless at the high-power end of SMD requirements and the low-power end of HEOMD requirements there may be technology commonalities, depending upon the system modularity (i.e., the number of units) of the HEOMD implementation. This level of detail is yet to be determined for the systems, but commonality in converter technologies appear to be the most promising areas for common investment.

Whereas the detailed applications and trades have changed over the decades, technical progress has typically not fared as well as initial expectations would suggest. The initial attempts to provide a NPS in the ~500-W_e range competed an RPS approach [5] against a FPS [6–8], but neither one achieved the initial goal in a timely manner (i.e., the SNAP program up through the mid-1960s). The use of high-efficiency, dynamic converters (using a boiling mercury Rankine-cycle) was discontinued with the early RPS approaches in favor of static, thermoelectric (TE) converters, in spite of their low conversion efficiencies [9].⁴

The quest for more efficient TE conversion materials has made slow but steady progress. The highest power use of RPS was with the GPHS-RTG on Cassini, with three units delivering a combined, beginning of mission (BOM) power of 889 W_e [13]⁵ using 54 GPHS modules each with four fueled clads (FCs) for a total of 216 FCs, each of which contains a nominal ~110 g of Pu-238 isotope [12].⁶ At the other extreme, the SNAP 10-A

³ There was no ALSEP package on the Apollo 11 mission, and the one on the Apollo 13 mission was not deployed on the Moon.

⁴ Subsequent work was performed on dynamic power conversion schemes at a variety of power levels including the Kilowatt Isotope Power stem (KIPS) using Rankine power conversion and Brayton Isotope Power Systems (BIPS), and then again in the 1980s for the Strategic Defense Initiative (SDI) and Space Exploration Initiative (SEI) [10–12].

⁵ Power as measured for the F-2, F-6, and F-7 units; see Tables 4 and 5 in [13].

⁶ This ~23.8 kg of Pu-238 used on Cassini may mark a practical upper limit to the amount of power on a spacecraft produced by using TE converters; it does mark the upper limit to the amount of power produced on a spacecraft to date using TE converters.

reactor produced about 40 kW of heat and using TE converters produced $\sim 500 W_e$, but at a smaller energy per unit mass than an RPS system.

There are 10 broad conclusions that can be drawn from this study. We summarize these here and refer the interested reader to the body of the report for the supporting information and analyses.

1. **NASA will need appropriately sized nuclear power systems to support robotic space missions for the period covered by the decadal surveys currently in force.** The 2011 Planetary Decadal Survey makes it clear that nuclear power systems are enabling for the implementation of high-priority planetary science missions (Table ES-1). There are no chemical, solar, or other nonnuclear power supplies known that can fulfill the need. Within the rest of the SMD, there are no currently identified missions requiring nuclear power within the Earth Science Division (ESD) or within the Astrophysics Science Division (ASD); identified missions all operate in near-Earth space (~ 1 AU) where solar arrays are generally adequate for power needs. Most identified missions within the Heliophysics Science Division (HSD) similarly operate near 1 AU and can use solar arrays. There have been and potentially are exceptions: the joint NASA-ESA Ulysses mission [14], the Solar Probe mission [15] as had been planned prior to its incarnation as Solar Probe Plus [16], and any outer heliosphere missions [3]. The latter category includes the Interstellar Probe concept contained within the report of the Panel on Solar and Heliospheric Physics in the Heliophysics Decadal Survey of 2013: “Solar and Space Physics: A Science for a Technological Society”⁷ [3].
2. **This need for nuclear power systems is expected to extend for at least one more decade past that covered by the current decadal surveys.** Given (1) current budget levels, (2) decadal survey priorities, and (3) NASA requirements as expressed to the DOE (most recently in 2010), nuclear power systems are expected to be required well into the 2030s at the least.
3. **Without significant budget increases in mission cost caps, projected, single-mission power requirements are unlikely to exceed $\sim 600 W_e$.** Mission cost is the primary driver for future planning, but the link between mission cost and power needs for a given spacecraft is not a simple one (cf. the rightmost column of Table ES-1). Current TE technology and planned plutonium dioxide production may just suffice to meet NASA needs at current PSD budget levels, but even this statement is highly contingent upon which RPS-powered missions are flown, in what order, and at what cadence. That is, the projected flight rate constrained by NASA program planning budgets aligns RPS demand with supply.
4. **Radioisotope Power Systems (RPS) with projected Pu-238 production rates and current technology may suffice to fulfill currently projected SMD needs.** The power requirement not exceeding $600 W_e$ is more efficiently fulfilled with an RPS than an FPS. RPS with projected NASA-funded Pu-238 production levels and current TE converters may fulfill SMD needs, albeit with little margin. The margin in question is driven by the flight-rate and power requirements on the one hand, and by the predictable production rates of FCs by DOE for GPHS modules on the other. The average Pu-238 production rate that is being established by the current NASA-funded Pu-238 supply project will be 1.5 kg of plutonium dioxide per year. A nominal 151 g of plutonium dioxide is used per FC. After the existing 35 kg of Pu-238 isotope is consumed, an average production of 9 to 10 FCs per year (a total roughly equivalent to two and a half GPHS modules per year) is anticipated. Pu-238 is a precious resource and needs efficient utilization and preservation. The other caveat is that low production rates could become a self-fulfilling, mission-limiting prophecy.
5. **Significantly increased capability⁸ in the rate of RPS electrical power available for missions is possible only with increased Pu-238 production rates and/or flight qualification of a dynamic converter.** To provide more programmatic (cost and schedule) resiliency, and to allow for additional or earlier RPS availability for even a limited mission set closely spaced in time, either higher efficiency

⁷ Interstellar Probe was not called out in the Heliophysics Decadal for implementation in the 2013 to 2022 time period. It was noted that given current budget constraints and the development of Solar Probe Plus (SPP), “the next major mission in heliophysics cannot be reasonably expected before 2024, or 6 years after SPP.”

⁸ Increases are possible also with increased TE efficiency, but not to the same extent.

converters—for example, TE enhanced MMRTG (eMMRTG) and/or dynamic Stirling—would need to be matured for flight (allowing for less Pu-238 usage for the same electrical power output) or an increase in Pu-238 production over time would be required.

6. **Converter technologies are independent of the nature of the nuclear heat source.** Both RPS and FPS rely on a nuclear heat source tied to an energy converter for electric power production in space. Heat-to-electrical conversion technologies are independent of how the heat is produced, be it via the natural decay of a radioisotope or via nuclear fission in a nuclear reactor. Lifetime, reliability, power level, and converter efficiency considerations, as well as overall power system cost, integration issues, and complexity, would likely drive selection of the approach to be implemented. Converters based upon advanced TE converters and/or dynamic power conversion (e.g., Stirling) not only have applicability to RPS, but they may have direct applicability to higher power FPS likely needed for human missions to Mars (HEOMD) as well as to RPS for SMD. The sizing and approaches to modularity may differ, but the underlying technology and materials issues may be common to both needs, depending upon how large the HEOMD modular FPS units need to be to satisfy HEOMD mission needs. For modular FPS units less than or equal to $\sim 4 \text{ kW}_e$, both TE and/or dynamic power conversion systems would be applicable with the assumed 1- kW_e reference conceptual power system. If HEOMD needs modular FPS units larger than 4 kW_e but less than 10 kW_e , only dynamic power conversion systems will be feasible for the assumed system due to thermal power limits of the 1- kW_e design reference system (DRS) reactor. At power levels from $\sim 10 \text{ kW}_e$ to several 10s of kW_e and even higher levels, Brayton converters may prove to be a competitive power conversion option to Stirling converters, and a different design reference reactor, e.g., a liquid metal cooled reactor, would be needed to provide the higher thermal power output needed to produce the higher electrical power. In any case, development of common power system converter technologies that feed both FPS and RPS represents a promising provisioning strategy.
7. **SMD has a continuing requirement to maintain and advance RPS for the next two decades and to plan for increased Pu-238 production rate over time.** The corresponding Pu-238 production rate needs to be at least at the minimum amount to keep the corresponding DOE infrastructure and personnel training in place and current. This observation regarding the infrastructure maintenance reinforces point 2 and sustainability needs.
8. **A space-based FPS could potentially enable higher power SMD missions, but only if the future need arises and sufficient new funds to develop an FPS flight unit are provided.** A novel, low-power, FPS-critical experiment is being funded (FY2015 to FY2017) by NASA's Space Technology Mission Directorate (STMD) in cooperation with DOE to demonstrate technical feasibility. Schedule and cost projections to first flight will not be investigated formally until a system development project is initiated, which is not currently planned and would not be considered until after FY2017. For the purposes of this study, such schedule and costs have been roughly estimated to be no less than 10 years and \$550 M.⁹
9. **FPS could be used on, but are not currently required for, SMD missions and would present technical challenges.** Radiation background, low specific power, and Assembly, Test, Launch, and Operations (ATLO), all present significant design challenges for FPS-powered robotic missions at the 1- kW_e power-level (roughly the lowest for which an FPS system makes technical sense). FPS-powered system mass would be greater than RPS-powered system mass at the 1 kW_e power level (this difference tends to increase as power level decreases); this fission system may currently be consistent with a Technology Readiness Level (TRL) ~ 2 to 3 compared with 9 for current RPS.
10. **SMD has no current requirements for a mission power system at the 1- kW_e level or higher, and so no current requirement for an FPS exists.** Absent requirements and with the current low TRL, SMD has no need to pursue FPS development per se, unlike the financial interest the Directorate does have to advance converter technology.

⁹ The cost of a 1- kW_e FPS using Stirling converters is estimated to be \$344M for design, development, test, and engineering (DDT&E) + \$80M for first flight unit + \$128M in DOE costs, for a total of \$552M (FY2014\$). This does not include any costs associated with infrastructure, reactor fuel, NASA Launch Approval Engineering, NASA Launch Services Program support, or security costs at Kennedy Space Center (KSC) or Cape Canaveral Air Force Station (CCAFS) to support a launch campaign.

NASA Nuclear Power Requirements

The panel assessed SMD requirements for nuclear power over the next 20 years as well as their extensibility to the needs of HEOMD. The NPAS did not consider nuclear thermal propulsion (NTP), as this is not an SMD requirement in any foreseeable mission scenario. The reactor power level for NTP is orders of magnitude larger, and reactor operating temperatures are factors of ~3 more, than what is required for SMD, and, partially due to the power level and higher operating temperatures and partially due to the direct application to propulsion, the fission fuel form and materials issues differ significantly from an FPS related to electrical power needs.

Cognizant of the decadal survey recommendations to which SMD responds, and the preponderance of applicability focused on robotic planetary missions, the analysis approach adopted was to respond to Planetary Decadal Survey consensus requirements. Specifically, we found that RPS is enabling for two Flagship recommendations, three additional Flagship candidates, and four New Frontiers candidates for which the electrical power requirements range from 144 W_e (for each of four landers) to 625 W_e . For these cases the lowest power requirements were for landers with 280 to 320 W_e required for the New Frontiers candidates.

Assessing the potential uses/needs for Discovery missions was more challenging, as nuclear powered Discovery missions were only offered in the Discovery 2010 Announcement of Opportunity (AO) (released 7 June 2010) [17], and, while two such missions requiring ASRGs were selected to proceed into Phase A, only the third, non-nuclear mission was selected for flight development. However, RPS had been identified as enabling for nine potential Discovery missions, which had been funded for closer study under the Discovery and Scout Mission Capabilities Expansion (DSMCE) investigation in 2007 [18] (Table ES-2). For these funded mission concept studies, the power requirements range from 130 to 267 W_e , with ~130 to 150 W_e required for landers/rovers. The solicitation for the funded studies assumes these power requirements could have been met by the ASRG. The power levels for these studies could also be met by the MMRTG and/or enhanced MMRTG (eMMRTG) [19] in considering future power needs; however, the implementations are not always interchangeable due to the additional waste heat generated by the TE, compared to Stirling, converters. All other concepts (from the decadal survey and funded DSMCE studies) were found to be feasible by using one to two ~300- W_e Pu-238-based RPS. Hence the NPAS concludes that all current SMD requirements could be met with a <1-k W_e RPS.

TABLE ES-2 | CHARACTERISTICS OF FUNDED DSCME STUDIES

DSMCE Study	~ Launch Mass (kg)	No. of ASRGs**	Required Power Level *** (W_e)	Lifetime (yr)
Mission 1	1,500	1	130	1
Mission 2	1,550	1	143	1
Mission 3	900	2	800 W_e peak (battery augmented)	3
Mission 4	3,600	2	148	1
Mission 5	2,400	2	262	8
Mission 6	1,500	2	212	11
Mission 7	1,500	2	223	14
Mission 8	1,500	2	254	9
Mission 9	1,400	2	267	10

* <http://science.nasa.gov/researchers/sara/grant-stats/grant-stats-archive/>

** DSMCE study baselined ASRG power output at 145 W_e BOM

*** Required power for the mission's active science phase

Requirements within HEOMD are not defined at this time, but potential focus is on human missions to Mars. In the HEOMD Mars Design Reference Architecture 5.0 [20,21], there are no current requirements for Pu-238-based RPS, but there are FPS needs [22]. Earth return of humans from the Martian surface requires a power

system that can deliver ~ 35 to 40 kW_e for in situ propellant production and also for crew habitat support during the surface stay. Practical approaches require an FPS, but the relevant architecture trades—the number of systems versus power output per system, as well as reliability, safety, and total costs constraints will remain undefined until no earlier than 2019.¹⁰

In assessing the extent to which nuclear systems are enabling for SMD, i.e., required, necessary, and sufficient to close engineering solutions, the NPAS observed that for current SMD requirements ($< 1 \text{ kW}_e$) Pu-238-based RPS systems are the preferred technical choice. This observation is largely driven by the fact that practical, currently envisioned FPS systems in this low power ($\sim 1 \text{ kW}_e$) range have a specific power (W_e/kg) lower than RPS by at least a factor of 3. For equal availability, the RPS approach is thus technically preferred.

Finally the NPAS also assessed the requirements of the current (FY2014) Agency Mission Planning Model (AMPM) [23],¹¹ which lays out a planned cadence of Discovery and New Frontiers missions from 2013 through 2033. An upper limit to needs can be assessed assuming the consideration of nuclear systems is to be allowed for these competed missions. However, assessment against competed mission slots also means that this class of potential nuclear-enabled missions is not determined until actual competition against issued AOs; hence, the requirements are non-deterministic.

Sustainability

Long-term sustainability of key capabilities that are necessary but used infrequently, is a well-known challenge in the aerospace industry and NASA, especially in times of tight fiscal constraints. Here “sustainable” must address efforts, which are themselves affordable, but also support an equally affordable mission set. A successful approach for the long-term must include a mix of production for flight programs in the pipeline as well as advanced technology developments for future use. Without such an approach technical knowledge retention becomes difficult and technical capabilities can stagnate and often wane, both of which can lead to a lack of real progress and instead just a cyclic activity of “reinventing the wheel.”¹²

Items of focus included the MMRTG (currently on Mars and powering the Curiosity rover) and several conceptual systems: (1) the eMMRTG (using advanced TE element manufacture being transferred to industry; “plug and play” for higher MMRTG efficiency), (2) Stirling convertor-based systems at a power level similar to those of the MMRTG or ASRG, (3) high-power Stirling radioisotope generator (SRG) ~ 200 to 300 W_e , and (4) the Advanced Radioisotope Thermoelectric Generator (ARTG), which would make use of advanced, segmented thermoelectric elements to reach conversion efficiencies of $>11\%$.¹³ All of these have potential future roles, but require consideration of technology sustainability, particularly if multiple systems are envisioned to be required for the future.

¹⁰ At this time it is expected that due to complexity and costs, the total power system would be substantially more expensive for systems made up of several, smaller power units rather than fewer, larger power units; therefore, HEOMD’s power level size decision will be driven toward the larger $\sim 10\text{-kW}_e$ systems.

¹¹ During the course of this writing, the FY2015 AMPM has been released for the time period 2014 through 2035 [24]; although some of the details differ from the 2014 version, there are no significant differences between the two that would affect any of the methodology in this study. The FY2014 AMPM shows four new Mars missions, three new Discovery missions, and three New Frontiers missions between 2018 and 2031. The FY2015 AMPM shows three new Mars missions, four new Discovery missions, and three New Frontiers missions between 2020 and 2034. The AMPMs are aligned with the FY2014 and FY2015 Congressional budget requests, respectively.

¹² Costs, outcomes, and problems encountered in several previous space nuclear power system efforts are well known by several members of the EC, MST, and SST, who had personally participated in some of these efforts.

¹³ For a modular concept ranging from 30 to 400W_e based upon 2014 ARTG studies using a cold junction temperature of 498K; better performance should be achievable with a cold junction temperature of 473K (similar to the cold-junction temperature of the MMRTG couples) (Fleural, private comm., 16 Dec 2014).

The NPAS did not reexamine older concepts and/or concepts more suited to higher power levels including Brayton and Rankine dynamic converters (higher power levels), thermionic and photovoltaic converters (have lifetime and radiator limitations) [25,26], and alkali metal thermal-to-electric converters (AMTECs) [27,28,29] or TE concepts that are not being considered for space use (e.g., copper selenides [30,31]).

Fission Power System Possibilities for SMD

Given the cost of NASA support of DOE infrastructure for supporting RPS for spacecraft and the costs associated with, and limits on the production rates of, Pu-238 for GPHS modules for RPS units, the NPAS took a very detailed new look at what the advantages/disadvantages and issues would be for using small FPS for support of SMD missions. The focus was on reactors that would be small compared with the notional 200 kW_e Prometheus reactor [32] for enabling large science mission with nuclear electric propulsion (NEP) [33] with the STMD KiloPower system concept used as a representative reference system in order to examine the potential applicability of FPS to SMD missions. A variety of salient issues were reviewed as discussed in the following subsections.

Technical

In terrestrial and naval applications, nuclear reactors typically use thermal neutrons, with the only exceptions being some research reactors and fast reactors for fissile fuel breeding. In space, minimization of mass is a driving requirement, and minimizing a reactor requires little-to-no moderator and, hence, a fast or epithermal reactor. In addition, the reactor shield to limit gamma-ray and neutron exposure of the spacecraft bus can also be a significant mass driver for the power system as a whole. To minimize the shield mass, a minimum size is also typically sought for the reactor core plus reflector, although there are also trades associated with spot shielding of electronics, reactor placement on a boom and its mass, and other considerations. Various design trades are intimately linked to these and other mission requirements such as design lifetime, making it difficult to make generalizations about the different approaches, which have been considered (cf. e.g., [34]). Space reactor designs using fast neutron spectrum approaches have uniformly incorporated highly enriched uranium (HEU), which is enriched to >92% in the fissile isotope uranium-235 (U-235). The earlier SNAP reactor designs, including the SNAP-10A, which flew in 1965, used HEU and differed only in being epithermal reactors, making use of uranium zirconium hydride (UZrH), originally selected partially due to the high costs [7] and other use priorities for HEU in the late 1950s [5], as well as other technical requirements.

Various fissile isotopes other than U-235 have been considered over the years for fueling a space reactor, notably U-233 [35]. However, alternatives to U-235, like U-233, involve a variety of safety and materials issues, and the U.S. practice of meeting the intent of the United Nations "Principles Relevant to the Use of Nuclear Power Sources In Outer Space" [36], specifically Principle 3 (nonbinding), requires the use of U-235. Space reactors developed both by the United States and the Soviet Union show that electrical power outputs at ~1 to 10 kW_e are feasible, but at low specific power (~2 W/kg at 1 kW_e).

Fuel availability

Unlike the case with Pu-238 for RPS, no new HEU will be produced in the foreseeable future, but DOE expects HEU to become available over the coming years to support U.S. space-reactor needs. In 2006, the DOE announced that in the coming years ~20 metric tons of HEU feedstock would be reserved for research, space, and medical isotope production reactors [37]. Specific set-aside amounts for this material were established, and allocations will be made as the HEU is removed from defense-programs use over the coming decades. Only a small fraction¹⁴ of the material in this reserve account is available for space reactors, and it must be shared amongst all users. No additional defense-related HEU is now foreseen as available due to long-range

¹⁴ The actual number is for official use only (OUO).

commitments and requirements. Additional HEU for space reactor application would require reprioritization of existing commitments and revision of current HEU allocations.

Fuel and security costs of FPS versus RPS

As part of this effort, technical experts from DOE and NASA (including NPAS members) have examined fuel, sustainment, facility, and security costs of HEU for an FPS versus Pu-238 for an RPS. Given the current state of the supplies and cost sharing for facilities [38], it can be assumed that the uranium enrichment is a sunk cost. In this case the use of HEU fuel by NASA, derived from retired nuclear weapons, for FPS is estimated at this time to be far less costly than plutonium dioxide fuel for RPS.

Due to the fuel form and concentration of fissile material for the FPS concept, the cost situation is reversed for security of HEU for FPS versus plutonium dioxide for RPS at either Kennedy Space Center (KSC) or the Cape Canaveral Air Force Station (CCAFS). Consultation with relevant parties has led to an estimate of the flight use of HEU imposing an additional ~\$30M nonrecurring cost for replacing or upgrading existing facilities used in processing RPS plus a further ~\$40M in recurring costs for security at the launch site (versus RPS) for each launch.

Flight FPS costs remain unknown

Perhaps the largest uncertainty is the cost and schedule for developing a compact FPS for space flight. Only one U.S. reactor has been flown – the SNAP-10A reactor on the SNAPSHOT. The reactor series used UZrH fuel and SNAPSHOT was launched in April 1965 into a near-polar orbit from Vandenberg Air Force Base on the California coast. The reactor automatically shut down by ejecting the beryllium neutron reflectors due to a non-nuclear fault (voltage regulator on the spacecraft bus) after 43 days of operation [39]; it remains in a 1300-km altitude, “nuclear-safe” orbit, although debris-shedding events of some level may have occurred [40].

The United States has spent billions of dollars on space reactor programs, which have resulted in only one flight of an FPS, i.e., SNAPSHOT.¹⁵ While these programs have assessed and advanced technologies, only that one has produced a flight system (e.g., Table III-1 of [46] and Table 1 of [47]). Examinations of these terminated efforts have revealed that materials issues and technology challenges produced common pitfalls. The driver of those was often the need to make large performance jumps from what was considered state of the art to satisfy the mission requirements. These issues led to cost overruns and, coupled with long lead times and large capital expenditures for ground testing and development to reach a flight-ready unit, as well as a lack of or cancellation of a mission, tended eventually to lead to program cancellations [7,8,32,33,41,46,48–50].

Recently NASA’s STMD funded the KiloPower Technology Development Project, investigating the feasibility of a simple, low-power (~1- to 10-kW_e) HEU-fueled reactor, with a long-lived potential [51], which lends itself to testing more easily. The approach adopted in that effort has been to look for modest incremental progress

¹⁵ By 1984 about \$840M real-year dollars had been spent, including “costs of record” of \$730M, an additional \$35M in unrecorded costs, \$35M for building test facilities, and an additional \$40M for equipping them [8]. With some overlap, the costs for the SP-100 program were “over \$420 M” then-year dollars from FY1983 through 1992 [41]. Total expenditures by the DOE Naval Reactor Program on Project Prometheus (for NASA) are \$110M [33]. The expenditures are comparable for the Department of Defense’s (DoD’s) Nuclear Electric Space Test Program (NEPSTP) [42] and the SDI’s Project Timberwind [43]. These numbers suggest then-year expenditures of over \$1B. A breakdown using FY2010 dollars yields the following [44]: missile and space propulsion \$1.69B (1950-1962) and space reactor power systems \$ 0.638B from FY1986 to FY1997. Numbers from 1963 through 1985 are not broken out, but would have been large due to the NERVA program, which ended in 1973. For comparison the Advanced Radioisotope Power System program from FY1986 through FY2000 spent \$0.958B in FY2010 dollars. Care must be exercised in using these numbers: as program elements are moved between different accounts from time to time or the program element names are changed; imputed costs for the RTG program in real-year dollars up through FY1985 is estimated as \$0.681B [45].

over previous work coupled to a simple design for low power levels (~few kW_e); limited operational temperatures; and SMD-based, modest performance goals. This approach has just begun (FY2015 to FY2017), and, given its low TRL, its ultimate applicability remains to be seen. However, the novel approach and potential for robust provision of FPS electrical power positions the concept for possible application both to future SMD and HEOMD needs and led the NPAS to consider it as the notional FPS to use as the reference FPS reactor heat source for this study.

PREFACE

Both nuclear power and the age of space exploration had their origins in World War II. The combination of the two rapidly found its way both into popular culture and science fiction. Their joint development was an outcome of the Cold War years, beginning in the second half of the 1940s. An initial report by the Douglas Aircraft Company [52] on the possibilities of artificial, Earth-orbiting satellites led to Project Feed Back [5], a plan for reconnaissance satellites capable of observing otherwise unviewable parts of the world with television cameras [53]. Such systems were scoped as requiring an onboard auxiliary power plant capable of continuously supplying 500 watts of electricity (W_e).

In the early 1950s the Atomic Energy Commission (AEC) was actively investigating the production of such power levels using both radioisotope power supplies and small fission reactors. The Systems for Nuclear Auxiliary Power (SNAP) program, initiated under President Eisenhower's Atoms for Peace program, pursued both approaches for space and terrestrial use [9,54,55]. While only one U.S. space reactor was flown (the 500- W_e SNAP-10A in April 1965), the radioisotope power program led to less-powerful, but more-used power systems on a variety of both U.S. military and scientific satellites. With evolving national priorities and needs, and with the end of the Cold War, use of such small nuclear power systems has shifted more and more to the National Aeronautics and Space Administration (NASA).

The relationship between NASA and the Department of Energy (DOE), successor to the AEC, for employing Radioisotope Power Systems (RPS) for space missions was most recently codified in a Memorandum of Understanding (MOU) between these two organizations in July 1991 (cf. Appendix N of [56]). Supplements to that agreement have guided the development, implementation, and flight of RPS since.¹⁶

In the late 1990s several technologies were being pursued as part of an Advanced Radioisotope Power System (ARPS) program [58]. A technical study in 2000 considered converter technologies for future development with overlap to the JPL X2000 technology development program and potential upcoming RPS-powered spacecraft [25]. At that time free-piston Stirling converters had been under development for some time by NASA, initially for use with the SP-100 space nuclear reactor project [10]. A conversion assessment for a small converter had been carried out in 1999 and a decision was made to proceed on the project [59–61]. About a year later in 2001, an RPS Provisioning Strategy Team issued a report summarizing NASA's then-estimated needs for RPS for the following decade and beyond [56].¹⁷ That report advocated two development projects: a Stirling RPS¹⁸ with higher electrical conversion efficiency and a new radioisotope thermoelectric generator (RTG) with less development risk, which could operate in the Martian atmosphere.¹⁹ Both would allow for operation both in deep space and in the atmosphere of Mars. The new RTG was viewed as a backup for the Stirling RPS, reducing both programmatic and development risks. Additional purchases of plutonium-238 (Pu-238) from Russia were viewed as required, as new domestic production was then thought not to be occurring until 2008 or 2009, and the immediate need would be to provide fuel for the RPS on the

¹⁶ There have been previous MOUs beginning with the flight of a SNAP-19 RPS on NASA's Nimbus spacecraft [57]. It was modified 13 times between 1965 and 1980 to cover mission changes and additional missions, the last being to provide radioisotope heater units (RHUs) for the Galileo mission. MOUs between the Agencies also addressed prior fission technology and system development efforts, with the most recent established in 2004 for development of a nuclear fission system for Project Prometheus.

¹⁷ Previous similar assessments focusing on RPS production and sustainment were undertaken periodically by the DOE and included NASA representation [62, 63].

¹⁸ With respect to the new Stirling RPS, the initial contract award was made by the DOE in August 2000; the scope was a funded study, with multiple contractors awarded identical scope during the procurement. As part of that effort, Lockheed Martin delivered a conceptual design report in February 2001, so this effort was well underway prior to the issuance of the RPS Provisioning Report that year. A subsequent modification to the contract, issued in May 2002, awarded the remainder of the contract phases to Lockheed Martin.

¹⁹ In the time between these two reports, the advocacy for continuing the AMTEK converter work had disappeared as technical problems continued to plague that program [27].

“Mars Smart Lander” (MSL) due for launch in 2007. The expected outcome, total cost for this dual strategy, was estimated to be \$319 to \$457 million (Table 3.4-3. in [56]; amounts are then-year dollars).

Just over 5 months from the issuance of that report, the world was changed by the 9/11 attacks on the United States. Security of associated new facilities was reconsidered, and the RPS activities at the Mound facility in Miamisburg, Ohio, were moved to Argonne National Laboratory—West, now part of Idaho National Laboratory (INL), outside of Idaho Falls, beginning in the Fall of 2002 [64]. Subsequently, the decision was made to store the neptunium-237 used as “feedstock” for Pu-238 production at INL as well [65]. By 2011, new domestic Pu-238 production had not yet begun, and the Stirling development was proving to be a challenge. However, the newest model of RTG (relying on technology similar to that of the SNAP-19 used on the Viking Mars landers), the Multi-Mission Radioisotope Thermoelectric Generator (MMRTG) [66], was developed and implemented successfully. MSL, rechristened as the Mars Science Laboratory mission with its subsequently named “Curiosity” rover, and the New Horizons mission to Pluto and the Kuiper Belt were launched (in 2011 and 2006, respectively)—the latter as a competed mission that is using the final remaining GPHS-RTG (General Purpose Heat Source RTG) of the generation employed on Galileo, Ulysses, and Cassini with a mixture of both newer and older Pu-238 nuclear fuel [13,67].

At this time, powered by the GPHS-RTG, New Horizons remains on course for its flyby of Pluto on 14 July 2015, and Curiosity continues in an extended mission on Mars, powered by its MMRTG [68]. The Solar Probe Plus (SPP) mission (confirmed for launch in 2018) and notional Europa Clipper mission both designed to use solar arrays have replaced the then-planned (in 2001), RPS-powered Solar Probe and Europa missions.

Ten years after the work of the RPS Provisioning Strategy Team, The 2011 Decadal Survey for Planetary Science, “Vision and Voyages for Planetary Science in the Decade 2013-2022” [2], makes the case for future missions enabled by the use of RPS; most of those mission concepts baselined the Advanced Stirling Radioisotope Generator (ASRG) [69]. At least partially motivated by a National Research Council (NRC) report on the topic of the importance of RPS to NASA programs [1], NASA has funded DOE to conduct a “Plutonium Supply Project” with the goal of reestablishing domestic production of Pu-238 and reaching an average production capability²⁰ of ~1.5 kg per year of plutonium dioxide (~1.1 kg per year of Pu-238) by early 2021. The first test targets containing Np-237 have been irradiated in the High Flux Isotope Reactor (HFIR) located at Oak Ridge National Laboratory (ORNL) to evaluate Pu-238 production [70].

Budget authority for NASA’s Planetary Science Division (PSD) has dropped from the levels expected at the time that “Vision and Voyages” was written, however. Recognizing that NASA continues to require RPS to support its missions, the Administration’s Fiscal Year (FY) 2014 budget proposed to shift the costs for all NASA-related RPS infrastructure to NASA via an addition of \$50 million per year to the PSD budget (cf. page SCI-9 of [71]). This was in addition to the project to restart domestic production of Pu-238, which has been funded by NASA since its inception in FY2012. The proposed infrastructure action was subsequently passed into law by the Congress [72].²¹ NASA chartered a “DOE RPS Infrastructure and Pu-238 Production Zero Base Review” in May 2013 to review the adequacy of the budgeted amounts [73]. That report was produced and briefed to NASA in September 2013 and delivered to the Office of Management and Budget (OMB) in early October 2013. In addition, the ASRG flight project was terminated shortly thereafter due to insufficient funds, leaving only the MMRTG as an available, flight-qualified RPS for NASA missions.

²⁰ The project objective is establishing capability, which will be the criterion for project completion and turnover to operations, rather than a production rate *per se*. The actual production rate for the resulting operation depends on NASA future funding decisions, based on its mission needs. In other words, this effort could provide a capability that does not do anything, if production is not required or funded for some time periods, as is the case in other parts of the infrastructure. Those decisions are beyond the scope of the project being described.

²¹ The requested monies were initially rejected per House Report 113-171 (accompanying H.R. 2787) and agreed to per House Report 113-135.

The current Nuclear Power Assessment Study (NPAS) was chartered by NASA on March 15, 2014, against this backdrop of events to “Discuss a sustainable strategy and present findings for the provisioning of safe, reliable, and affordable nuclear power systems that enable NASA Science Mission Directorate (SMD) missions and is extensible to Human Exploration and Operations Mission Directorate (HEOMD) needs in the next 20 years.” (“Terms of Reference,” “Objective,” cf. Appendix A) This report contains the methodology used, analyses performed, and the findings that resulted in the course of conducting the NPAS.

ACKNOWLEDGMENTS

The Executive Council gratefully acknowledges the skilled help of the many people who have contributed to the successful execution of this study and compilation of this report. In particular, the efforts of Young Lee and the Mission Study Team, of Joseph A. Sholtis, Jr. and the Safety, Environmental Protection, Launch Approval and Security Team, and of Lee Mason and the Systems Study Team were invaluable and crucial in carrying out this study. Similarly, the various NASA and DOE facilities that provided support via their Collaborative Engineering Centers and support for the many technical interchange meetings are gratefully acknowledged. We finally thank our alternates on the Executive Council, who have played a vital role in making certain that the study continue in a timely fashion, and, especially, the tireless efforts of the Study Coordinator, June F. Zakrajsek, and the Executive Secretary, Kathryn K. Trase, in coordinating and supporting all of the study efforts. Finally we owe a debt of gratitude to Kristin M. Spear and the Editorial Staff at the NASA Glenn Research Center in producing this study report.

Nuclear Power Assessment Study

RADIOISOTOPE POWER SYSTEMS PROGRAM

1 | INTRODUCTION

The Nuclear Power Assessment Study (NPAS) was chartered by the NASA Planetary Science Division (PSD), and coordinated by NASA's Radioisotope Power Systems Program to examine the provisioning of nuclear power systems for a variety of NASA needs.

NASA has identified a long-term need to develop more efficient nuclear power systems to support both NASA's Science Mission Directorate (SMD) and Human Exploration and Operations Mission Directorate (HEOMD). In addition, the SMD seeks to understand the potential for commonality between components of possible Radioisotope Power Systems (RPS) and Fission Power Systems (FPS).

This study was performed with collaboration from NASA centers including the Glenn Research Center (GRC), Goddard Space Flight Center (GSFC), Johnson Space Center (JSC), Kennedy Space Center (KSC), and the Jet Propulsion Laboratory (JPL); the Department of Energy (DOE) and its laboratories, including Los Alamos National Laboratory, (LANL), Idaho National Laboratory (INL), Sandia National Laboratories in Albuquerque (SNL), and the Y-12 National Security Complex (Y-12); the Johns Hopkins University Applied Physics Laboratory; and, independent consultants. The NPAS was conducted from 15 March through 5 September of 2014.

1.1 | Study Objectives and Terms of Reference

The NPAS Terms of Reference (Appendix A) led to several topics for consideration and evaluation by the team. A possible strategy for technology development and capability sustainment was discussed. Nuclear safety and mission and infrastructure impacts of potential RPS and FPS on mission concepts were also examined.

As with the 2001 RPS Provisioning Study [56], the Terms of Reference do not include investigation of non-nuclear alternatives to RPS and FPS technologies. Consequently, any conclusions or findings reached should not be construed as reflecting on the desirability, technical feasibility, or economic viability of non-nuclear technologies.

1.2 | Study Organization

The NPAS was guided by an Executive Council (EC) and conducted by two primary technical teams: the Mission Study Team (MST) and the Systems Study Team (SST). The two technical teams conducted in-depth assessments of mission and systems concepts to address specific considerations provided in the Terms of Reference and answer questions from the EC. The EC was comprised of stakeholders from the appropriate NASA mission directorates, flight centers, the Department of Energy, and nuclear safety. The EC assimilated reports from the technical tier teams and developed the findings contained within this report. Study participants were selected to encompass a diverse set of experiences to ensure NPAS encompassed a broad view of technology options, mission concepts, and organizational practices.

1.3 | Study Methodology

The MST and SST selected Design Reference Missions (DRMs) and Design Reference Systems (DRSs) to form the foundation upon which technical trades and assessments were based. Nuclear power system performance, technology readiness, cost, and safety as well as operational flexibility, served as a basis in developing the system options and the DRMs. Two existing Flagship-class mission concepts from the 2011 Planetary Science Decadal Survey “Vision and Voyages for Planetary Science in the Decade 2013 – 2022” [2] were studied by the MST: the Titan Saturn System Mission (TSSM) and Uranus Orbiter and Probe (UOP). Mission science and instrumentation were constrained to remain consistent with the decadal survey concepts, while the spacecraft power systems were revised to accommodate the new power system options provided by the SST. The DRSs included conceptual, advanced thermoelectric (TE) as well as Stirling converters, which could be utilized in both notional radioisotope and fission system concepts.

The technical teams also considered the extensibility of the DRSs to other potential users. The MST evaluated the applicability of the DRSs to smaller Discovery and New Frontiers mission classes. The future needs of NASA HEOMD, as stated in its Mars Design Reference Architecture 5.0 [21], were compared to the potential capabilities of the DRS notional concepts.

The MST and SST evaluated mission and systems concepts in the context of the entire system development and mission lifecycles. The MST enumerated options for Assembly, Test, and Launch Operations (ATLO) for both RPS and FPS concepts. The technical teams also assessed nuclear safety, launch-approval processes, and security implications of the notional conceptual systems for the DRMs. The SST prepared notional flight system development plans and examined the impact of fuel availability, infrastructure, and ground-test activities on the notional, proposed system concepts. Both technical teams developed cost estimates for the power-system development and implementation on the DRMs. Chapters 2, 3, 4, and 5 provide a summary of the technical work completed by the study teams. Chapter 6 provides the summarized findings from this technical work. Details of the methodologies used are included at the beginnings of each chapter.

The technical work performed by the MST and SST was provided to the EC for review. The EC distilled the technical data from the teams into the findings discussed in this report. These findings address the study considerations listed in the “Terms of Reference” (Appendix A).

2 | DESIGN REFERENCE MISSIONS

The 2008 Titan Saturn System Mission (TSSM) study [74] and 2010 Uranus Orbiter and Probe (UOP) mission concept developed for the Ice Giants [75] were the two decadal survey studies selected to become Design Reference Missions (DRMs) for the Nuclear Power Assessment Study (NPAS), primarily because their technical details and mission cost estimates exist in the public domain. Both missions were identified as being high priorities for planetary exploration by the decadal survey.

The TSSM concept required a total power of 540 W_e at end of mission (EOM) using 2008 Advanced Stirling Radioisotope Generators (ASRGs) producing 135 W_e EOM each. The UOP concept required a total power of 368 W_e at EOM using the 2010 ASRGs producing 122.5 W_e EOM each. Each DRM was studied by replacing the ASRGs with higher-powered Radioisotope Power Systems (RPS) and Fission Power Systems (FPS) and investigating the necessary accommodations required and their resulting impacts on the mission.

2.1 | Mission Study Goals and Methodology

The Mission Study Team (MST) sought to understand potential future mission needs for RPS and FPS, considering power system efficiency and mission reliability requirements. To determine the applicability of power systems considered for NASA missions and the associated science or exploration returns, the MST developed DRMs using both notional RPS and FPS to investigate and understand the capabilities required of these power systems. The MST specifically investigated the impacts of the considered power systems in the areas of mission development, integration, operation, reliability, lifecycle cost, risk, and safety. The MST also assessed security constraints at the launch site.

The MST employed the point-design studies approach over “delta” studies in order to learn how systems function from a mission perspective and characterize power-system requirements. The MST leveraged the previously studied mission architectures, technical details, and cost estimates from the decadal survey study as a reference point for NPAS mission-study comparison purposes. The MST developed the DRMs from the original concepts described in the decadal survey and added the necessary accommodations for the notional power systems. For power system comparisons, both RPS and FPS were studied on the same mission to improve the credibility of study results. For assessing mission commonality, the MST evaluated multiple missions to obtain more analysis information and better assess total mission costs. The MST constrained the DRMs to apply the original science goals and payloads, baseline launch vehicle, and mission design from the original decadal survey concepts.

Following each mission study, the MST generated ROM mission costs and assessed commonalities between the concepts utilizing RPS and FPS. In parallel to the DRM studies, the MST examined the notional power system impact to conventional ATLO activities at NASA Kennedy Space Center (KSC), including launch integration, security, and radiological contingency planning. In addition to conducting the DRM studies, the team assessed the impact of radiation, gamma rays, and neutrons potentially emanating from the RPS or FPS on science instrument design and measurements. The MST evaluated the nuclear power system technologies commonality to different applications: from science missions to potential human exploration missions to Mars. The MST also analyzed the typical power requirements of various science mission classes.

For Human Exploration and Operations Mission Directorate (HEOMD) missions, the MST did not perform any detailed mission studies, as was done for the Science Mission Directorate (SMD) missions, but relied primarily on the previous Mars Design Reference Architecture (DRA) [20] study and recent HEO Architecture Team study updates [22] as a basis for HEOMD needs because there was insufficient time and funding to conduct HEOMD studies to the same level of detail as for the SMD missions.

The MST, led by the NASA Jet Propulsion Laboratory (JPL), was formulated with representation from the Johns Hopkins University Applied Physics Laboratory (APL), Department of Energy (DOE), NASA Glenn Research

Center (GRC), NASA Goddard Space Flight Center (GSFC), Idaho National Laboratory (INL), JPL, NASA Johnson Space Center (JSC), KSC, and Sandia National Laboratories (SNL) (see Appendix B).

2.1.1 | DRM Selection Overview

At the NPAS kick-off meeting at NASA Headquarters on May 1, 2014, the NPAS Executive Council (EC) recommended the 2008 TSSM and 2010 UOP to be the DRMs, primarily because their technical study contents and mission cost estimates exist in the public domain and these were two of the top-rated mission concepts in the decadal survey exercise. Table 2-1 shows the criteria and rationale used for the NPAS DRM selection.

TABLE 2-1 | NPAS DRM SELECTION CRITERIA

Criteria	Rationale
Planetary Science Decadal Survey Mission	<ul style="list-style-type: none"> • Consensus around priority science objectives • Existing mission concepts and cost estimates • Domestic and international interest
Multi-faceted mission architecture	<ul style="list-style-type: none"> • Multiple mission facets provide robust de-scope options while maintaining scientific value • Mission concept may benefit from additional power • Mission concept is sufficiently challenging to demonstrate capabilities needed in the future
Mission concept cost estimate exceeds cost cap with the use of solar electric propulsion (SEP)	<ul style="list-style-type: none"> • Deferred missions subject to less perceived “favoritism” by science community • Mission not feasible with current technologies – NPS may enable • Enables assessment of Nuclear Power Systems’ (NPS’s) potential ability to reduce mission cost

The RPS studies for UOP and TSSM were assigned to APL and JPL, respectively, as was done for the decadal survey. FPS studies with TSSM and UOP were assigned to GRC since the Collaborative Modeling for Parametric Assessment of Space Systems (COMPASS) laboratory has previously conducted FPS-based mission concept studies.

2.1.2 | Decadal Survey TSSM Concept Overview

The TSSM study [74] was aimed at developing a comprehensive, international mission to explore the Saturn system, with particular emphasis on the moons Titan and Enceladus. The study built on results of earlier Titan mission concepts, with specific direction from NASA. This study and its predecessors were intended to support a joint NASA-ESA (European Space Agency) down-select to a notional, single, Outer Planets Flagship Mission planned for 2009.

The baseline mission concept for TSSM integrates an orbiter and ESA-provided in situ elements into a single flight system. Key mission parameters are shown in Table 2-2.

TABLE 2-2 | TSSM MISSION CONCEPT PARAMETERS

Parameter	Value
Launch Date	Sep 10–30, 2020
Start SEP Thrusting	Dec 1, 2020
End SEP Thrusting	Oct 14, 2025
SOI	Oct 28, 2029
Flight time to Saturn	9 years
TOI	Sep 29, 2031
SEP ΔV	~2.7 km/s
SEP Propellant	451 kg
Chemical Propellant	2528 kg
Chemical ΔV	~2.4 km/s
Orbiter Current Best Estimate Dry Launch Mass	1,081 kg
Orbiter Dry Mass Margin	532 kg
SEP Stage Current Best Estimate Dry Launch Mass	502 kg
SEP Stage Dry Mass Margin	276 kg
In Situ Elements Current Best Estimate Launch Mass	579 kg
In Situ Element Airborne Support Equipment	43 kg
In Situ Elements Launch Mass Margin	211 kg

The TSSM orbiter (Figure 2-1) would be a three-axis stabilized spacecraft powered by RPS that has strong similarity to the Cassini orbiter. The TSSM orbiter concept includes an articulated 4-meter high-gain antenna (HGA) using Ka-band for high-rate science data downlink. A planned payload of six instruments plus radio science is accommodated, with the model instruments located on a payload deck as well as other locations on the spacecraft, dictated by their observational requirements. Accommodation for the two in situ elements (ESA-provided Lander and Montgolfier) is provided at attachment points along the body of the orbiter. Five ASRGs would power the spacecraft, with four estimated based on information available at the time to provide 540 W_e of electrical power at the end of mission (about 13 years after launch) with a fifth unit carried as a spare. The TSSM architecture was designed also to be compatible with use of MMRTGs. Redundant 25 A-hr Lithium-ion (Li-ion) batteries provide for power demands that exceed the RPS capability during the science-mapping orbit and at other times during the mission. The launch mass of the flight system would be 6,203 kg. This is within the Atlas V 551 capability of 6,265 kg to the required launch energy. The flight system design includes ample mass and power margins. In addition, the use of SEP allows for significant mass growth of up to 300 kg beyond the current margins with a minimal impact of up to a 1.5-year longer flight time.

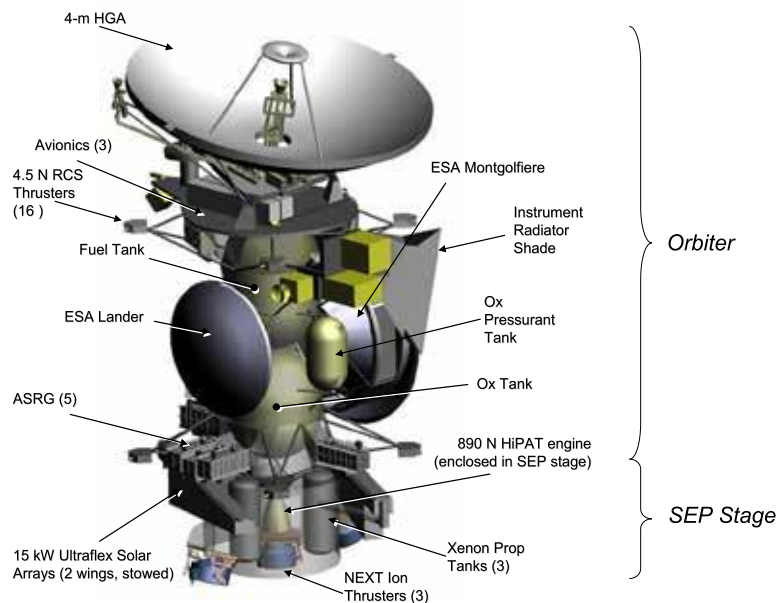

FIGURE 2-1 | DECADAL SURVEY TSSM CONCEPTUAL FLIGHT SYSTEM

2.1.3 | Decadal Survey UOP Concept Overview

The 2010 ICE Giants Decadal Study [75] was directed to define a preferred concept approach for a Uranus or Neptune mission that would launch in 2020–2023. Uranus was ultimately selected as the more accessible and lower risk option that could be achieved within the specified launch time frame.

A low-thrust, SEP-trajectory option was developed to reach Uranus, based on a single Earth-gravity-assist (EGA) that could be repeated every year, using an Atlas V (531) launch vehicle and a 20-kW_e (1 AU) SEP stage that would be released after the first 5 years of the 13.4-year cruise. No Jupiter flyby opportunities were available for the time frame considered. The selected trajectory enabled a mission concept, which fully accommodated both the floor- and enhanced-science payload through a 2.4-year science campaign with three phases: Uranus Capture and Probe Delivery (29 days), Primary Uranus Science Orbit (20 orbits in 431 days), and a Uranian Satellite Tour (424 days). The full mission duration totals 15.4 years. The UOP mission science objectives and requirements are described in detail in the “Ice Giants Decadal Mission Study Final Report” [75], and remain unchanged for the 2014 NPAS study.

The notional 2010 UOP flight system includes an orbiter and deployable atmospheric entry probe. The notional Orbiter science payload consists of a wide-angle camera, magnetometer, and visible/near-IR mapping spectrometer (floor payload), as well as an ultra-stable-oscillator, mid-IR thermal detector, UV imaging spectrograph, narrow-angle camera, and plasma instrument (enhanced payload). The atmospheric entry probe would be equipped with a mass spectrometer and temperature-pressure sensors (floor), as well as an ultra-stable oscillator and nephelometer (enhanced). Duty cycling of instruments is not required during science operations. The primary payload elements on the 2010 UOP spacecraft concept are shown in Figure 2-2. Additional details can be found in the 2010 decadal report [75].

Key 2010 Decadal Survey UOP Orbiter element parameters are summarized in Table 2-3. Additional flight system design details can be found in the decadal report [75].

The full mission cost estimate developed for the 2010 UOP mission concept baseline totals \$1,894 M (FY2015 dollars), falling within the study target range of \$1.5 B–\$1.9 B (FY2015). This estimate includes launch vehicle costs and assumed \$20M for each ASRG (unfueled).

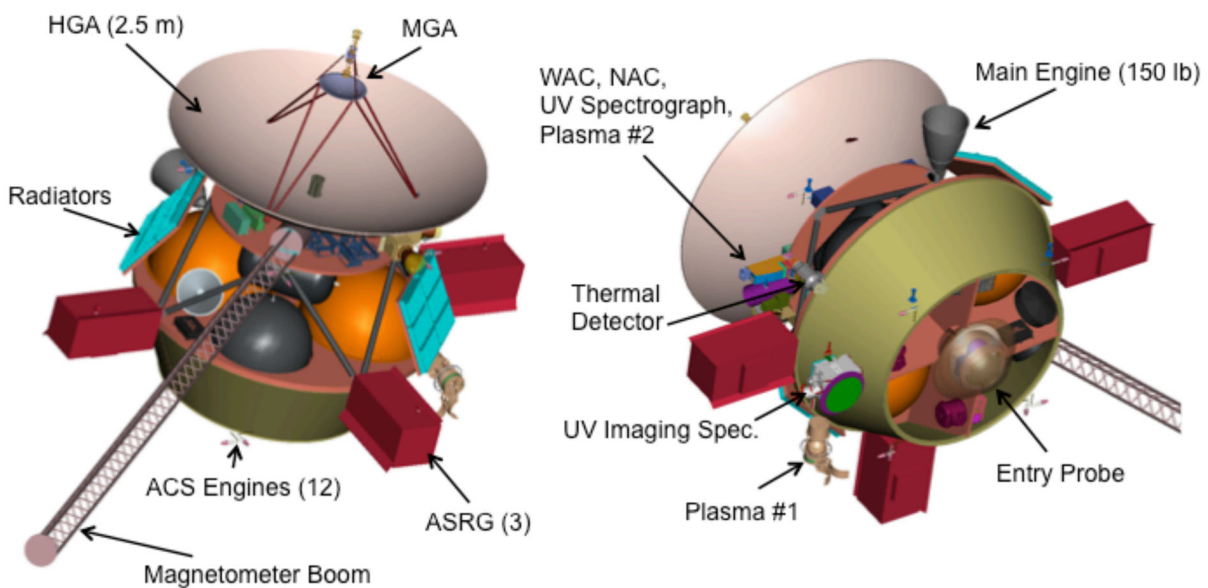

FIGURE 2-2 | DECADAL SURVEY UOP CONCEPTUAL SPACECRAFT LAYOUT

TABLE 2-3 | DECADAL SURVEY UOP CONCEPTUAL ORBITOR KEY PARAMETERS

Orbiter Element Parameter	Value/Summary, units
Design life	15.4 years
Structures	<ul style="list-style-type: none"> Aluminum cone adapter, honeycomb decks, and struts Magnetometer boom
Orbiter Mass (excludes probe)	2,217kg (wet), 906kg (dry), including margin
Thermal Control	“Thermos bottle” approach: heat pipes, louvers, thermostat controlled heaters
Propulsion	Dual-mode chemical; 2,500m/s ΔV
Attitude Control	<ul style="list-style-type: none"> 3-Axis: SEP phase, maneuvers, science Spin: hibernation and probe delivery Knowledge: +/- 100 microradian Control capability: 0.1 degrees Pointing stability: 5 microradian/sec
Command and Data Handling	<ul style="list-style-type: none"> Housekeeping data rate: 300 bps (sci) Data Storage Capability: 32 Gbit
Power	<ul style="list-style-type: none"> Primary source: 3 ASRG: 438 W_e BOL, 367.5 W_e EOL, 1-year storage Average consumption (with margin): On-orbit avg. 314-363 W_e (science), Peak: 606 W_e (maneuvers) Battery: Li Ion, 16.8 amp-hours

2.1.4 | DRM Ground Rules

In order to manage the scope of the study and to provide a good comparison with the original decadal survey TSSM and UOP studies, the NPAS Executive Council established ground rules for the NPAS mission studies. They are:

- Use the published decadal survey studies as the authoritative source for information regarding the decadal-survey, mission-concept baseline.
- Retain the science goals and objectives, science requirements, and instrument payload as specified in the decadal studies.
- Focus on power system accommodations for the orbiter and treat the in situ elements or Entry Probe as “black box” payloads.
- Use the mission design approach from the decadal survey studies including use of an SEP Stage and the launch vehicle.
- Match the decadal survey study reserves approach.
- Use the descriptions, properties, interface data, and other required inputs for the 2014 SRG and ARTG system concepts as provided by the NPAS System Study Team.
- Update the original decadal study cost estimate to reflect the 2014 power system accommodations, and report the results in FY2015 dollars. Additional guidance for the NPAS study includes the use of decal survey study science payload costs, and the exclusion of launch vehicle and technology-development related costs. The study team was also directed to retain line items for the new RPS unit costs, but with the cost set to zero during mission design sessions.

2.2 | NPAS DRM Results

2.2.1 | Summary

The TSSM RPS and FPS studies by NPAS explored the utility of increasing EOM power from 500 W_e to 1,000 W_e , with the capability to (1) simplify spacecraft design by replacing the 4-meter antenna (which has a heavy gimbal and strict pointing requirements), (2) increase instrument duty cycles and data return, and (3) possibly enable different payload choices, such as high-powered, active instruments.

The UOP RPS study examined new RPS at the 300-400 W_e EOM power level as a replacement for the ASRG. The new UOP RPS concept improves on the ASRG-based performance, particularly compared to that using the 2014 ASRG mass and power estimates.

Variable unit sizing of power system levels was also examined for each revised concept. TSSM selected concepts with the 6-GPHS SRG and 16-GPHS ARTG concepts to achieve a $\sim 1,000 W_e$ EOM power level, with a maximum of four power units (including redundant units) to avoid configuration and integration issues. In contrast, UOP selected the 4-GPHS SRG and 9-GPHS ARTG concepts to achieve 370 W_e EOM power while meeting mission's tight mass and configuration constraints.

Based on these two study results, the redundancy policy for a mission was noted to be a major driver to differentiate RPS options when considering future implementations.

The TSSM study with the SRG option included a redundant unit, which drove up mass compared to ARTG option. The UOP study considered SRG options with and without a redundant unit, resulting in a significant mass difference between those two options.

2.2.2 | NPAS TSSM RPS Study Results

The goal of the study conducted by JPL was to determine the potential system-level benefits, both technical (system mass reduction and mission duration increase) and programmatic (mission cost reduction), due to the additional power generation afforded by the considered new RPS. The NPAS TSSM 1- kW_e RPS study, performed by JPL's Team X, concluded that the TSSM mission could be done using the new notional RPS—SRG and ARTG—at the 1 kW_e power level. The higher power level would allow for simplification of the spacecraft telecom and power subsystems, and increased power margins, which could be allocated to science. Spacecraft mass would increase slightly due to the increased RPS mass.

2.2.2.1 | NPAS TSSM RPS Study Ground Rules and Method

The RPS parameters for the NPAS TSSM RPS study were provided as study inputs by the System Study Team, assuming a GPHS module producing 250 W_{th} BOL.²² EOM powers are given for a 17-year lifetime (3 years on the ground and 14 years in operation).

The sparing strategy is to include one spare unit for Stirling RPS cases and no spares for thermoelectric RPS cases, based on the decadal survey TSSM study approach and on initial estimate of RPS and spacecraft reliability requirements. Hence, the sparing strategy used the decadal survey TSSM study's decision not to include electric power from the spare unit in any of the power balance or available power totals; the additional unit is purely a spare.

²² The Step 2 GPHS and its nominal BOL power output are assumed.

The Team X design team started with the decadal survey TSSM study design and analyzed the effects flowing from replacing the power system with the new RPS, which would increase the available power. The subsystems significantly impacted were power, thermal, structures, and telecom.

The primary design goals were to use the extra power to reduce system complexity by: (1) reducing antenna size (using larger TWAs to maintain data rate), (2) reducing battery size, and/or (3) replacing the propellant tank heat source via ASRG waste-heat cooling loops with electrical heaters.

The final notional spacecraft designs utilize the first two options.

The MST evaluated two SRG concepts, the 6-GPHS module and 4-GPHS module SRG, and two ARTG concepts, the 16-GPHS module and 9-GPHS module ARTG, on the NPAS TSSM. Detailed system findings for these NPAS TSSM options can be found in a separate report: “NASA Nuclear Power Assessment Mission Studies for Enabling and Extending Future Space Exploration” (RPS-RPT-0121, JPL D-81712) [76].

The MST also updated the decadal survey TSSM Study concept that utilized ASRGs in order to compare the results of integrating the new RPS concepts within the NPAS TSSM. Mass and power performance parameters of the ASRG were updated to reflect the most recent 2014 estimates. The report NPAS Mission Studies report [76] discusses the impacts to the decadal survey TSSM in light of updated ASRG performance parameters.

Additionally, the study was tasked with providing updated ROM mission costs based on each of the new power system options.

2.2.2.2 | NPAS TSSM RPS Study – Questions Answered

A list of initial study questions were developed by the NPAS Mission Study Team, along with corresponding answers based on the findings developed by the NPAS TSSM RPS study. Detailed questions and corresponding answers can be found in the NPAS Mission Studies report [76].

2.2.2.3 | NPAS TSSM RPS Study Options Summary

The primary findings of the NPAS TSSM RPS Study, excluding costing results, are summarized across all studied configurations in Table 2-4. The relative cost of these configurations is addressed in Chapter 5 of this report.

2.2.3 | NPAS UOP RPS Study Results

The goal of the study conducted by APL was to investigate the accommodations required to replace the three ASRG power units baselined in the decadal survey study with updated, 2014 versions of Stirling (SRG)-based and Thermoelectric (TE)-based RPS concepts. The main objectives for the study were to investigate the potential for higher power availability and to understand the potential mission sensitivities to the new power systems, while at the same time ensuring that the resulting mission concept remained feasible. Additionally, the study was tasked with providing updated ROM mission costs based on each of the new power system options. The new UOP RPS concept was able to improve on the ASRG-based performance, particularly when compared to using the 2014 ASRG mass and power estimates.

TABLE 2-4 | NPAS TSSM 1kW_e RPS STUDY OPTIONS SUMMARY

Subsystem	2008 ASRG	2008 Study with 2014 ASRGs	3+1 6–GPHS Stirling	5+1 4–GPHS Stirling	3 16–GPHS ARTG	5 9–GPHS ARTG
Telecom	X/Ka, 4 m antenna, 35WRF TWTA	X/Ka, 4 m antenna, 35WRF TWTA	X/Ka, 2.25 m antenna, 140WRF TWTA. -3 kg	X/Ka, 2.25 m antenna, 140WRF TWTA. -3 kg	X/Ka, 2.25 m antenna, 140WRF TWTA. -3 kg	X/Ka, 2.25 m antenna, 140WRF TWTA. -3 kg
Power	4 Operating + 1 Spare. 107 kg and 541 W EOM.	5 Operating + 1 Spare. 205 kg and 575 W EOM.	3 Operating + 1 Spare. 187 kg and 891 W EOM. Smaller batteries, non-RPS mass -5 kg.	5 Operating + 1 Spare. 192 kg and 965 W EOM. Smaller batteries, non-RPS mass -5 kg.	3 Operating + 0 Spares. 163 kg and 1,041 W EOM. Smaller batteries, non-RPS mass -5 kg.	5 Operating + 0 Spares. 161 kg and 945 W EOM. Smaller batteries, non-RPS mass -5 kg.
Thermal	Passive cooling loop heats prop tanks with ASRG waste heat.	Passive cooling loop heats prop tanks with ASRG waste heat.	Uses mechanically-driven pumped fluid loop to utilize SRG waste heat. +12 kg	Uses mechanically-driven pumped fluid loop to utilize SRG waste heat. +12 kg May require additional cooling loops.	Can passively radiatively heat prop tanks with ARTG waste heat. -23 kg	Can passively radiatively heat prop tanks with ARTG waste heat. -23 kg May require additional cooling loops.
Structure	Composite and Aluminum for low mass, rigidity. 350 kg.	Effects of other subsystem mass increases not studied. On order of +20 kg.	Other subsystem mass increases drive mass +20 kg	Other subsystem mass increases drive mass +21 kg Need to accommodate 6 units.	Effects of other subsystem mass increases not studied. On order of +6 kg.	Effects of other subsystem mass increases not studied. On order of +6 kg. Need to accommodate 5 units.
Dry Mass (with margins)	3,224 kg	~3,400 kg	3,350 kg	~3,360 kg Configuration and Thermal may add mass.	~3,270 kg	~3,270 kg Configuration and Thermal may add mass.

* Green color denotes positive changes for a potential mission; red color denotes negative changes for a potential mission

2.2.3.1 | NPAS UOP RPS Study Approach, Challenges, Constraints, and Assumptions

The overall study approach adopted by the ACE Lab study team for the UOP RPS analysis consisted of the following elements: review of the original decadal survey mission concept baseline and all SRG and ARTG unit options provided by the System Study Team, examination of various combinations (based on size and quantity) of both the SRG and ARTG units, selection of optimal SRG-based and ARTG-based system configurations that would enable the updated UOP mission concept to work successfully, identification of driving accommodation requirements and effects relative to the decadal survey mission baseline, and estimation of UOP total mission ROM cost deltas as a consequence of the 2014 power system updates.

Upon initial analysis, it was quickly determined that the NPAS UOP RPS study would be driven fundamentally by mass constraints, given the study ground rules and the physics of delivering a sufficiently instrumented payload to Uranus orbit within an acceptable mission duration. Given that the decadal survey baseline mission design, launch vehicle (Atlas V-531), and 20 kW_e (1AU) SEP stage would be retained, the NPAS study update was constrained by the 2010 Orbiter total dry mass allocation of 711.7 kg (the maximum expected value, including contingency but excluding unallocated margin). Other key constraints for the study include: total post-launch mission duration (15.4 years); retaining a spin-balanced spacecraft design; and, avoiding changes to the science payload configuration in accommodating the 2014 SRG units.

The orbiter mass constraint described above drives the key trade for the NPAS RPS study: the number of RPS units of either type that could replace the three 2010 ASRG units within existing mass allocations, while still meeting or exceeding the decadal survey UOP power output.

The initial estimates of ASRG unit mass and power values used in the decadal survey UOP study had undergone revision in the course of further ASRG development activity. As of 2014, the ASRG mass estimate had increased, and the expected power output had decreased, relative to the 2010 values. The study team decided to continue to reconfigure the NPAS UOP Orbiter using the original, 2010 ASRG mass and power allocations, but would also report on the changes required to accommodate the 2014 ASRG versions on the baseline orbiter (along with the 2014 SRG and ARTG options that are the subject of this study), as a basis for comparison.

Another key assumption driving RPS selection and sizing involves the time of unit fueling (beginning of life, or BOL) relative to launch (beginning of mission, or BOM). The BOL is the basis point for projecting power system output throughout the mission lifetime, as the thermal output of the nuclear fuel degrades as a function of time. The decadal survey UOP study had assumed the ASRG fueling (BOL) would occur one year prior to launch (BOM). The UOP study team revisited this assumption to make sure whether the same assumptions can be applied. Upon consultation with NPAS team members representing DOE, the following was assumed for the NPAS UOP RPS study: For a three-unit SRG system, it is suggested that the fueling and testing should begin 24 months prior to launch. For a two-unit ARTG system, it is suggested that the fueling and testing sequence should begin 18 months prior to launch. Power output levels calculated for key events in the UOP mission timeline were based on these DOE-recommended, pre-launch, fueling schedules, coupled with the power output degradation factors supplied by the NPAS System Study Team for the SRG- and ARTG-based system options.

The NPAS UOP RPS study team evaluated two options of the 4-GPHS SRG concept, and one option of the 9-GPHS ARTG concept on the NPAS UOP after careful evaluation of power system sizing based on the mission's mass and power constraints. Detailed system findings for these NPAS UOP options can be found in the NPAS Mission Studies report [76].

The MST also updated the decadal survey UOP Study concept that utilized ASRGs in order to compare the results of integrating the new RPS concepts within the NPAS UOP. Mass and power performance parameters of the ASRG were updated to reflect the most recent 2014 estimates. The NPAS Mission Studies report [76] discusses the impacts to the decadal survey UOP in light of updated ASRG performance parameters.

2.2.3.2 | NPAS UOP RPS Study - Questions Answered

A list of initial study questions were developed by the NPAS Mission Study Team, along with corresponding answers based on the findings developed by the NPAS UOP RPS study. Detailed questions and corresponding answers can be found in the NPAS Mission Studies report [76].

2.2.3.3 | 2014 UOP Replacement Options Summary

The primary findings of the NPAS UOP RPS study, excluding costing results, are summarized across all studied configurations in Table 2-5. The relative cost of these configurations is addressed in Chapter 5 of this report.

TABLE 2-5 | NPAS UOP RPS REPLACEMENT OPTIONS SUMMARY

Subsystem	2010 Baseline ASRG	2010 Decadal with 2014 ASRGs	(2+1) x 4-GPHS Stirling SRG	(2+0) x 4-GPHS Stirling RTG	2 x 9-GPHS ARTG
Power	3 Primary + 0 Spare. 82 kg and 368 W _e EOM.	4 Primary + 0 Spare. 132 kg and 436 W _e EOM. (2014 est. output power lower than 2010)	2 Primary + 1 Spare. 110 kg and 588 W _e EOM. Minor shunt regulator component changes.	2 Primary + 0 Spare. 74 kg and 392 W _e EOM.	2 Primary + 0 Spare (plus 1 thermally isolating bracket each). 98 kg and 379 W _e EOM.
Avionics	Typical, Redundant APL Integrated Electronics Module, 32Gbit recorder.	No change	Potential for minor modifications to CMD and TLM interface.	Potential for minor modifications to CMD and TLM interface.	Potential for minor modifications to accommodate additional temperature sensor inputs.
G&C	Redundant Star Trackers, IMU, Sun Sensors, RWAs, Maneuvering Thrusters, Monopulse input from RF	No change	Removal of monopulse tracking as part of RF mass savings option	No changes required	Removal of monopulse tracking as part of RF mass savings option
Telecomm.	Dual Ka and X Band; 2.5m HGA; 40-W Ka, low EMI TWTA, Monopulse	No change	1.8m HGA; Removal of Monopulse; 14kg subsystem reduction	No changes required	1.8m HGA; Removal of Monopulse; 14kg subsystem reduction
Thermal	“Thermos bottle” design with heat pipes, louvers, controlled heaters	Potential minor modifications for higher shunt power	Potential minor modifications for higher shunt power	No significant changes expected	Thermal isolating mounting brackets required. Relocation of components in ARTG thermal view likely required.
Mechanical / Structural	Aluminum structure, built around large HGA and large dual-mode propulsion system	Future analysis of layout & mass props needed to account for placement of 4th ASRG & mass increase	No significant structural changes expected	No significant structural changes expected	Future analysis of layout needed; Effects of ASRG radiant heat on nearby components to be studied.
Orbiter Dry Mass MEV	712 kg	~763 kg	~727 kg	~704 kg	~722 kg

2.2.4 | NPAS TSSM FPS Study Results

The TSSM 1-kW_e FPS study demonstrates that the notional 1-kW_e FPS could be used on the TSSM mission launched on an Atlas V 551 using a simple, fixed boom, and could nearly double power for gathering science data for TSSM.

One of the main objectives of the COMPASS FPS study was to answer the question: *Could a FPS-based TSSM mission succeed using the decadal survey TSSM study reference design by replacing the ~550 W_e ASRG systems with a 1.0-kW_e nuclear reactor, using either a Stirling or thermoelectric power conversion systems?*

The NPAS TSSM FPS Study did find a mission solution with both Stirling and TE FPS concepts, with increases in trip times of two years and three years, respectively. The longer trip time is due to the additional SEP spiral cruise time, which is necessary due to the higher FPS mass. This SEP spiral cruise would not be required for the lower mass RPS TSSM options.

The Stirling and TE FPS concepts evaluated by COMPASS for TSSM did utilize common power conversion technologies that could bridge RPS and FPS as well as SMD science and HEOMD mission power needs. This mission study demonstrates that FPS could be compatible with Flagship-class science missions if such power levels were needed.

2.2.4.1 | NPAS TSSM FPS Study Approach, Ground Rules and Assumptions

The GRC COMPASS Team conducted the TSSM 1.0-kW_e FPS study in June 2014 using the two 1.0-kW_e FPS options, Stirling and TE versions, provided by the System Study Team. While there was a strong desire to maintain as many features of the original decadal survey TSSM study baseline as possible, some changes were required to accommodate the two slightly different FPS concepts [77].

In addition to following the DRM ground rules (see Section 2.1.4 DRM Ground Rules), further ground rules invoked were: (1) The fission reactor would not be used to power electric propulsion, in order to investigate implementations of FPS without nuclear electric propulsion; (2) A fixed boom should be used to avoid the risks associated with use of deployable booms; and (3) Use of the Atlas V 551 would be preferred over other launch vehicles, in order to minimize nuclear launch costs and be comparable to the baseline TSSM.

The System Study Team provided the FPS parameters based on the reactors in the decadal survey 2010 NASA/DOE Small Fission Power System Feasibility Study [78]. The FPS were designed to the following requirements: 1 kW_e, 15-year full-power design life, 28-Vdc bus, and a 10-year flight system development.

The final version of the developed FPS-based conceptual designs, shown in Figure 2-3, remained on the Atlas V 551, kept a fixed boom, and still used the SEP stage, chemical propulsion and aerobraking. The SEP stage was key in keeping the FPS-based TSSM spacecraft on the Atlas V 551: the fission system was ~300 kg heavier than the previous RPS system, but SEP would allow the spacecraft to launch with negative C3 to a near geostationary transfer orbit (GTO) and then spiral out to escape. The SEP stage would provide the orbiter system with ~500 W_e of power through the spiral out and Earth flybys so that the reactor would not need to be started until after the last Earth flyby. Benefits to this approach are: eliminating the potential reentry risk associated with an operated reactor flying by the Earth, reducing the required operating lifetime of the reactor and reducing the total radiation dose from the reactor. This approach would allow the required reactor shield mass to be reduced as well.

Due to the addition of the reactor and starting in GTO, the vehicle would take an additional 2-3 years to arrive at Titan. However, the additional power that would be available from the reactor versus the ASRGs would allow the suite of science instruments to be run concurrently, eliminating science “campaigns” and thus almost doubling the projected science data returned from Titan (from five gigabits to nine gigabits).

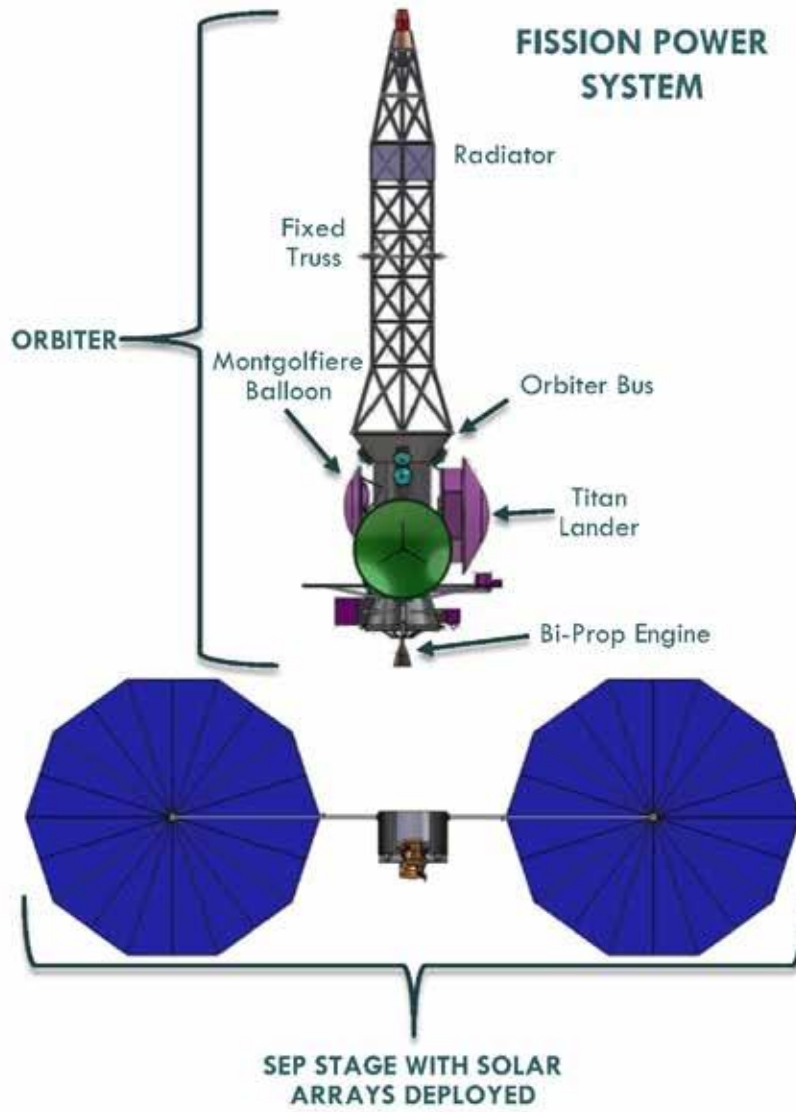

FIGURE 2-3 | NPAS TSSM 1kW_e FPS SPACECRAFT CONFIGURATION

2.2.4.2 | Mission Accommodations

Fission power systems do not scale favorably at very low power levels. However, while there is a several hundred kilogram mass increase using FPS over RPS at this low power level, there is merit in understanding what the mission impacts would be if FPS were used, in particular, for the higher-power science missions.

The TSSM FPS study relied on some key findings of the NPAS TSSM RPS 1.0-kW_e study Team X session, which was performed prior to the FPS study session and served as the study's point of departure. Some key Team X findings also adopted in the FPS concepts are: (1) Adopt a reduction in communications antenna size from 4 meters to 2.25 meters to allow antenna relocation to accommodate a "top"-mounted FPS; (2) Increase TWTA capability from 35 W_e RF to 140 W_e RF; (3) Replace the propellant-tank ASRG cooling loops in the decadal survey TSSM study with electric heaters (a possible future trade with heating loops from an FPS radiator); and (4) Maintain the same instrument suite but perform simultaneous instrument operation and almost double the data return.

The following accommodations were necessary to allow the mission to work with the FPS options that were considered, i.e., both the 1.0-kW_e Stirling and 1.0-kW_e Thermoelectric systems: (a) While retaining the baseline Atlas V 551 launch vehicle, a tall, 23-meter fairing, to replace the decadal survey TSSM's short 20-meter fairing, is necessary to accommodate the total height of the FPS attached to the fixed boom; (b) The SEP-stage solar array would increase from 15 kW_e to 19 kW_e to allow the reactor to be unpowered during Earth flybys; (c) The SEP-stage propellant would increase from 450 kg to 1,534 kg for the Stirling option, and to 1,950 kg for the TE option and add one additional NASA Evolutionary Xenon Thruster (NEXT) thruster for the TE option only; (d) The total mission duration would increase for electric-propulsion, Earth-spiral durations of two years for Stirling and three years for the TE options; and (e) A Titan aerobraking, 4.5-meter, drag plate would be added for both FPS options. Detailed descriptions of mission accommodation discussions and detailed subsystem findings of the NPAS TSSM FPS Study can be found in the NPAS Mission Studies report [76].

ATLO approaches specific to FPS were developed during the study and further developed by the FPS ATLO team (Section 2.3).

Most spacecraft reactor concepts have the reactor situated some distance from the spacecraft, utilizing an optimization of shield mass and boom/cable mass to minimize the total ionizing dose (TID) to electronics parts, instruments, and other materials degraded by radiation. The study's FPS design was set at a TID of 25 krad at a dose plane of 10 meters during a notional 15-year mission. This allows for 25 krad from the space environment that could be accommodated for missions other than those in the vicinity of Jupiter. A shield of tungsten and lithium hydride along with a 10-meter boom provides the 25-krad design point.

The main shield casts an 11.6-degree, half-angle, cone shadow with a projected base radius of 2.25 meters at 10 meters distance to protect the spacecraft systems except for the communications antenna, which protrudes beyond the 2.25 meters. To accommodate the antenna, the shield shape is augmented with an extended section of 80 degrees in circumference with a 19.0 degree half-angle. This configuration results in a section of 3.5-meter, projected, cone-base radius at the 10-meter separation distance, which would completely shield the deployed antenna articulation ranges and avoid any potential back-scatter radiation concerns.

2.2.4.3 | NPAS TSSM FPS Study – Questions Answered

A list of initial study questions were developed by the NPAS Mission Study Team, along with corresponding answers based on the findings developed by the NPAS TSSM FPS study. Detailed questions and corresponding answers can be found in the NPAS Mission Studies report [76].

2.2.4.4 | NPAS TSSM FPS Study Options Summary

The COMPASS FPS study assessed the replacement of the ~550-W_e ASRG-powered system of the decadal survey TSSM Study with Stirling and TE-fission power options and showed that it is possible to find a mission architecture solution that would meet requirements. This study’s results also could be compared to the results from Team X study, which replaced the TSSM 2008 ASRGs with future concepts of the ARTG and SRG also capable of providing ~1 kW_e.

The masses of the FPS options would be greater than the RPS options and, therefore, the FPS options required some mission redesign and orbiter reconfiguration of the decadal survey TSSM concept. In particular, the mission durations of the FPS concepts were increased, due to the need to launch to a GTO orbit and subsequently spiral out of Earth orbit.

Table 2-6 provides a summary recap of the of the mission parameters of the original decadal survey TSSM concept with the Stirling and TE FPS concepts. The relative cost of these configurations is addressed in Chapter 5 of this report.

TABLE 2-6 | COMPARISON OF THE DECADAL SURVEY TSSM STUDY AND FPS CONCEPTS

Subsystem	2008 ASRG	1 kW _e Stirling Reactor	1 kW _e TE Reactor
Science	108 kg, 182 W _e , ~5Tb Data Return	108 kg, 182 W _e , ~9Tb	108 kg, 182 W _e , ~9Tb
Mission	~13 yr	~15 year (1 year Earth spiral-out)	~16 year (2 year Earth spiral-out)
Launch Vehicle	Atlas 551, short fairing. C3 of 0.6 km ² /s ² (6250 kg Stage Mass)	Atlas 551, long fairing. C3 of – 14.8 km ² /s ² (8300 kg Stage Mass)	Atlas 551, long fairing. C3 of – 22 km ² /s ² (9600 kg Stage Mass)
SEP Stage	~15 kW _e , 500 kg Xe, 2+1 NEXT	~19 kW _e , 1,400 kg Xe, 2+1 NEXT	~19 kW _e , 1,800 kg Xe, 3+1 NEXT
Orbiter Power System	171 kg, >13 yr operation time	~500 kg, ~7 yr [reactor NOT activated until after final Earth flyby (~7 yr after launch)]	~700 kg, ~7 yr [reactor NOT activated until after final Earth flyby (~7 yr after launch)]
Aerobraking	4 m antenna for drag area, ballistic coefficient 77 kg/m ² (2 month aerobraking campaign)	4.5 m drag flap plus 2.25 m antenna same 77 Ballistic coefficient (2 month aerobraking campaign)	4.5 m drag flap plus 2.25 m antenna 80 ballistic coefficient (~2.1 month aerobraking campaign)
Communications	X/Ka, 4 m antenna, 25/35 W radio frequency (RF), 140 kbps	2.25 m antenna, X/Ka, 70/250 W RF, 250 kbps	2.25 m antenna, X/Ka, 70/250 W RF, 250 kbps
Attitude Control System (Titan Ops)	Four, 25 Nms, local vertical, local horizontal (LVLH) around Titan	Four, 150 Nms reaction wheels, Gravity Gradient around Titan	Four, 150 Nms reaction wheels, Gravity Gradient around Titan
Total S/C Dry Mass (with margins)	~3,200 kg	~4,200 kg	~5,000 kg

* Green color denotes positive changes for a potential mission; red color denotes negative changes for a potential mission

2.2.5 | NPAS UOP FPS Study Results

The GRC COMPASS Team conducted the NPAS UOP 10.0-kW_e FPS study in August 2014, adapting the NPAS TSSM 1.0-kW_e FPS study experience. Although the initial approach of replacing the decadal survey UOP study ASRGs with the 1.0-kW_e FPS while maintaining the 20-kW_e solar electric propulsion (SEP) stage appeared feasible, the Mission Study Team found that it would not meet requirements because UOP is a more propulsive-demanding mission than the TSSM.

2.2.5.1 | NPAS UOP FPS Study Approach, Constraints, and Assumptions

Several major constraints of the decadal survey UOP RPS design had significant impacts on the UOP FPS design. Key constraining factors are: (1) system mass limits, (2) exclusion of a Jupiter flyby due to the limited number of flyby opportunities, and (3) acceptable mission duration. The initial approach envisioned was to replace the three ASRGs of the decadal survey UOP mission concept with a 1.0-kW_e FPS. However, the significantly mass-constrained launch of the decadal survey UOP mission concept on an Atlas V 531 provided little-to-no margin for the heavier 1.0-kW_e FPS. Based on lessons learned from the NPAS TSSM 1.0-kW_e FPS study, it was determined that a mission architecture solution using even the larger Atlas V 551 and SEP could not be found.

It was then decided to expand the trade space beyond the initial ground rules by investigating a mission option using a multi-kilowatt FPS design and replacing the SEP with a nuclear electric propulsion (NEP) stage to determine if this scenario could provide a mission solution.

In order to accommodate NEP, the decadal survey UOP study parameters were modified to replace the SEP stage with a 7.5 - 10 kW_e nuclear electric propulsion system integrated into the Uranus Orbiter. The NEXT electric propulsion system was unchanged from the decadal SEP option and the same NEXT thruster configuration (2+1 spare) was retained. The probe would still be jettisoned at Uranus orbit insertion.

The study selected Stirling FPS due to its power-output capability. TE FPS was eliminated from consideration due to its lower power; the thermal capability from the reactor concept design is limited to 50 kW_{th}, which in turn limits TE FPS output power to < 4 kW_e.

Proposed mission options that were assessed include: (1) Maintain the decadal survey UOP mission's Atlas V 551 or use a Delta IV Heavy; (2) Launch to escape ($C_3 > 1$) and activate the NEP stage; (3) Avoid Earth Flybys (Venus or Mars flybys were assumed to be acceptable); (4) a Jupiter flyby would not be considered for launch dates past 2021 using NEP; (5) Use NEP to slow down the spacecraft at Uranus to reduce the chemical propellant, which would be required for capture into orbit (~100 kg) (maintain insertion into a highly elliptical orbit as utilized in the decadal survey UOP mission study); and (6) Evaluate the option of keeping the NEP stage for the Uranus-moon-tour mission phase. This option would provide higher power for simultaneous science instrument operation and could also enable an extended moon tour beyond the 2 years base-lined in the decadal survey UOP study.

A comparison of the base-lined decadal survey UOP RPS mission and the NPAS UOP FPS mission characteristics along with detailed descriptions can be found in the NPAS Mission Studies report [76].

2.2.5.2 | NPAS UOP FPS Study Summary

The mass-constrained UOP mission did not allow a retrofitting of a 1.0-kW_e FPS option while maintaining the decadal survey UOP study guidelines. However, a solution was found having an Earth flyby after nearly two years of reactor operations to support NEP, an approach which also held the promise of larger science data returns. The Mission Study Team and the COMPASS Team discussed this option with the NPAS Executive Council, and the council determined that one ground rule for mission design options involving a first-of-a-kind FPS would be no Earth flyby with an operated reactor (~2 years in this case), due to nuclear safety considerations regarding potential Earth impact. Earth flybys of a subsequent flight-proven FPS would not necessarily be so constrained; they would be assessed based on information available at that time.

The science team conducted a top-level evaluation of the potential benefits of having high power for the Uranus moon tour as compared to the decadal survey UOP study and estimated an order-of-magnitude increase in data return using the same instruments to collect more images. Additionally, if the NEP stage remained with the moon probe, the potential extra delta V could prolong the moon-tour phase and also contribute to additional science data acquisition.

The UOP NEP study could be revisited after a reactor launch safety assessment and the development of new protocols.

2.2.6 | Mission Opportunities with Higher Power

Based on observation of the NPAS mission studies, it was recognized that some missions could be designed to take advantage of higher power if the power source is more capable:

- Systems could be designed to turn on more science instruments simultaneously to enhance science return. The scenarios become easier to plan if all of the instruments could stay powered on independently of each other. The reliability of the instruments could potentially be improved by reducing the number of power cycles.
- The amount of data return could be improved if the downlink is power-positive and ground passes could be added throughout the mission. Some mission concepts may allow an increase in power to the transmitter or the ability to transmit in two bands simultaneously to increase the amount of data return.
- The data rate of the system data bus for the spacecraft could be increased with more power. This could eliminate local data storage at the instrument and simplify the architecture. An increase in power could increase the amount of data storage available on the flight system.
- A higher-power source could eliminate the need for a waste-heat-recovery thermal system and enable the use of thermostats and computer-controlled heaters, simplifying the system and improving the overall reliability.
- Higher power sources could enable the use of electric propulsion, improving the mass margin of some missions. Electric propulsion at the science target may increase the opportunities for extended missions and other targets.

2.3 | Assembly, Test, and Launch Operations (ATLO) for Nuclear-enabled Missions at Kennedy Space Center: RPS and FPS

2.3.1 | Summary

The use of a small FPS to enable a space mission would be a new challenge for NASA KSC, although some features would be common with previous work encountered in preparing RPS missions for launch. The current notional FPS would be a compact reactor that would generate approximately 1 kW_e of usable power. The use of this type of system would pose specific challenges in the area of Assembly, Test, and Launch Operations (ATLO) of a FPS-powered mission. The intent of ATLO is to start with the various components required of the specific NASA mission (instrumentation packages, spacecraft, rocket fairing, nuclear power system, etc.) and, by the conclusion of operations, have a fully-prepared rocket with mission-specific payload hardware on the launch pad tested and ready for launch.

The current ATLO concept of operations to support a nuclear-powered mission involves a specific subset of buildings at KSC and Cape Canaveral Air Force Station (CCAFS): the Radioisotope Thermoelectric Generator Facility (RTGF), the Payload Hazardous Storage Facility (PHSF), the Atlas Vertical Integration Facility (VIF) at Space Launch Complex-41 (SLC-41), and any connecting roadways between these structures that the nuclear materials would travel upon.

The ATLO operations at KSC typically transpire over a six-month period immediately prior to launch. However, the preparations for these operations start approximately five years prior to launch. A significant activity that takes place outside of this six-month window is the Trailblazer or Pathfinder exercise, which is a detailed dress rehearsal of all procedures involved in handling the power system, its nuclear material, and any system associated with them. This activity typically takes place 12-18 months prior to launch, and requires the exercise of all detailed procedures by all organizations involved (NASA mission team, DOE, KSC, USAF, etc.).

The various combinations and permutations of assembling an FPS, providing for power system check-out, providing for a fully integrated check-out with spacecraft systems, and then movement of the various systems to the VIF and launch pad, were thoroughly considered, analyzed, and assessed by the ATLO team based on currently available information.

A total of six different scenarios were developed and analyzed, which considered the use of existing and new ATLO capabilities and then were compared with each other. Based on undesirable potential discriminators, including the need for possible re-design of the Atlas V fairing and significant modifications to the VIF internal structures, the number of attractive options decreased to only two. Both of these remaining ATLO concepts would involve fully integrating the FPS into the launch vehicle fairing prior to movement of the fairing to the VIF for integration with the rocket. The difference of these two options involves whether the PHSF was used for the effort or a new nuclear facility would be required based on several concerns, including security.

2.3.2 | Nuclear Mission ATLO Team's Objectives

To ensure that end-to-end mission development and operations phases were addressed to capture complete mission perspectives, and to encourage mission-level trades rather than system-level trades to occur, an ATLO team was stood up as part of the NPAS effort. The objectives of this team were to: (1) identify assumptions and ground rules that could apply to ATLO assessment, (2) identify ATLO constraints that could have impacts on the System Study Team's nuclear power system designs in order to minimize their local optimizations, (3) identify system operability and affordability requirements that could impact ATLO, (4) identify any new FPS deliverables that would need to be developed, considering the current set of RPS deliverables, (5) develop a

high-level notional ATLO flow, (6) identify nuclear safety and security needs, and (7) identify areas requiring future investigation.

2.3.3 | ATLO Assessment Development Process

The following processes, shown in Figure 2-4, were used to perform KSC ATLO assessment studies:

2.3.4 | ATLO Assessment Approach

The use of existing ATLO processes and functions for RPS systems was the starting point used for developing various options for use with a FPS. To the extent possible, the same buildings were utilized for the various functions. If the particular function could not be accomplished in an existing facility, modifications to that facility and/or a new facility were considered. With the low level of maturity of the current conceptual FPS and HEOMD’s still-yet-to-be-defined FPS requirements that could impact the size, concept, and design of FPS, the ATLO team felt that it was important to be as inclusive as possible in considering all ATLO options. If the FPS conceptual design undergoes changes at a later time, the choice of which ATLO option to pursue could also change.

2.3.5 | New RPS Assessment

2.3.5.1 | Radioisotope Thermoelectric Generators

The typical ATLO process for RTGs has been employed over the last several decades to support missions such as Cassini, Galileo, Ulysses, (Pluto) New Horizons and Mars Science Laboratory (Curiosity). There have been some subtle changes in the process to keep up with changes in two key areas (transportation and safety analyses). The basic flow will be briefly discussed.

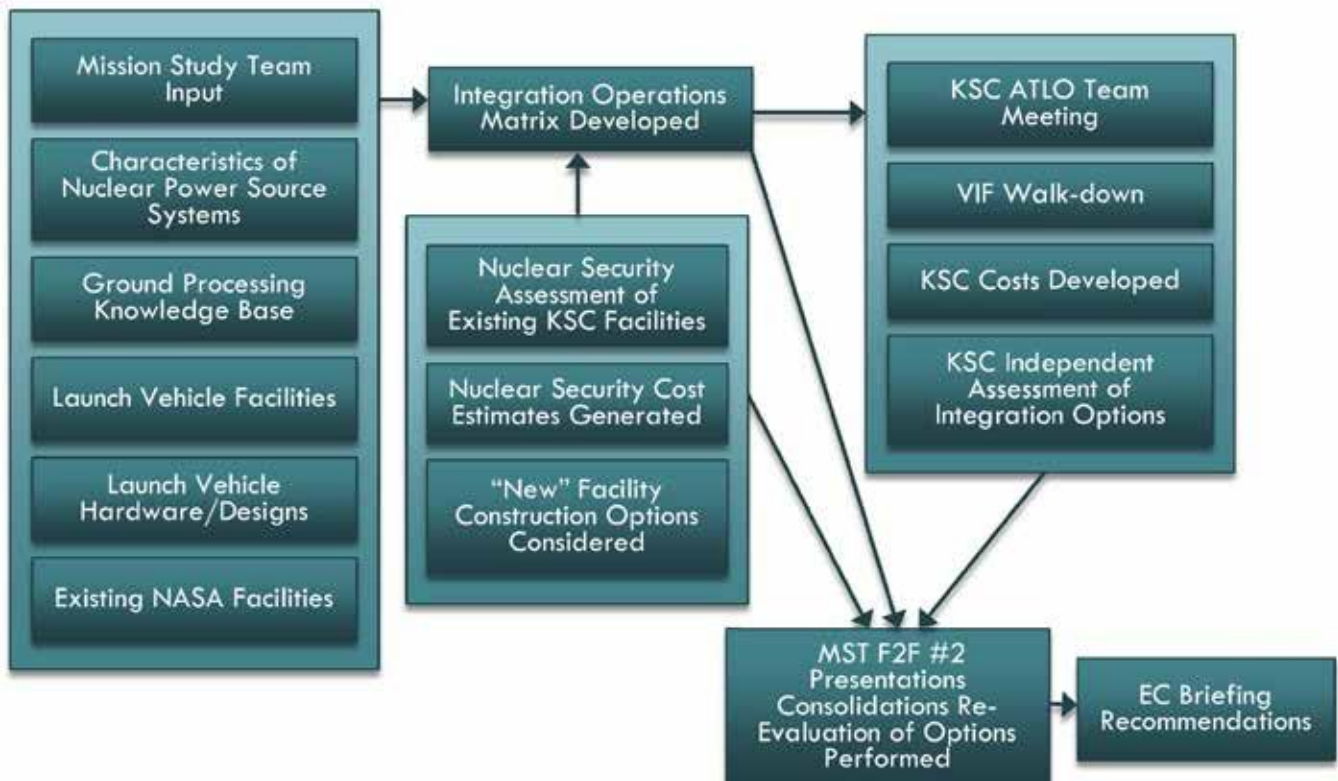

FIGURE 2-4 | ATLO ASSESSMENT PROCESS

The power system is shipped typically 4-6 months prior to the launch date to a storage/staging building at KSC (typically, the RTGF). This facility allows for separation of the nuclear power system-related operations from the more conventional spacecraft ATLO operations. Another key operation occurs when the power system is taken from the RTGF to the PHSF and attached to the spacecraft to perform a final risk reduction operation called a “hot fit” check. This procedure typically takes 1-2 days, and provides the final verification that the spacecraft flight hardware electrical and mechanical integration operations could precede with the lowest possible risk at the launch pad. Additionally, the hot fit check at the PHSF provides a final opportunity to power up the spacecraft with the flight RTG, and confirm in a near “test like you fly” configuration, that there should be no interference issues or obvious operational constraints imposed by the actual flight article during the mission.

Approximately one week before the launch date, the RTG is moved from the RTGF to the VIF near the launch pad (SLC-41 for an Atlas V mission). The fairing and encapsulated spacecraft would have already been moved from the PHSF and mated to the launch vehicle, approximately 2-4 weeks prior to launch. The RTG is lifted approximately 150 feet (~ 45 meter) onto an upper level of the VIF and placed onto a specialized cart for integration of the RTG with the spacecraft through a large, mission-unique fairing door.

The fairing door is typically located in the cylindrical portion of the fairing and allows for access to the spacecraft or rover inside the fairing. This integration event can take from a few hours to several days, depending on the complexity of the interaction between the RTG and the spacecraft.

Other operations that are part of this process include: (1) “Trailblazer” or “Pathfinder” operation which is typically scheduled to occur 12-18 months prior to launch, with significant post-event lessons learned reviews following the event, (2) Final dry run or “dress rehearsal” delivery of the RTG simulator to the VIF occurs approximately 2-3 weeks prior to actual delivery of the flight RTG, and (3) Extensive preparations of the nuclear safety processes to be applied during the presence of nuclear material at KSC starts 3-4 years prior to launch.

Detailed discussions and changes of RTG ATLO flow processes can be found in the NPAS Mission Studies report [76].

2.3.5.2 | Stirling Radioisotope Generator Systems

The General Purpose Heat Source (GPHS) module (Step 0,1,2) has been the same heat source for all RPS-powered NASA missions since the advent of this design in the early 1980s [13,79–81]. This would continue to be the case for the Stirling convertors currently envisioned for the near future. Due to this similarity as well as other constraining factors, the changes between the RTG and SRG systems from an ATLO perspective are projected to be minimal. The same fundamental steps would be used. A building would be used as a central storage area (RTGF), the PHSF would be used for a hot fit check, and the VIF would be used for final integration. The cost of development, including all certifications, of a new shipping container would likely constrain the physical size of the SRG to fit the capabilities of the current shipping system. Some accommodations likely would be necessary to allow for the intricacies of the controller for the Stirling convertor and for the possibility of a change-out of the controller under extreme circumstances, but not enough is known about these potential actions at this time to determine any special ATLO considerations.

2.3.6 | FPS Assessment**2.3.6.1 | Compare or Contrast with Existing RPS Experience**

RPS have been used by NASA and launched from KSC since the 1960s, and the related ATLO processes are well understood. The one and only use of a space nuclear reactor system, SNAP-10A, was a power system for a space mission SNAPSHOT, launched in 1965 from Vandenberg Air Force Base in California. A nuclear-fission-based system has never been handled or integrated into a spacecraft at KSC or CCAFS. Additionally, the protocols for handling and integrating such a system, as well as the current launch vehicle designs and associated ground processing procedures, have undergone many significant changes since the 1960s. The NPAS Executive Council therefore deemed it important to analyze what additional accommodations at KSC might be required and/or desired for an FPS.

The FPS considered here would be delivered either fully assembled (core in place) or as two packages, with the core being separate from the reactor housing. In either case, there would be no plan to test the exact core/reactor set prior to it arriving at KSC in a power-generating mode. Given the current knowledge base, the ATLO team therefore envisioned that this activity would occur at KSC.

An FPS would then require some means of replicating the RPS “hot fit” check with the spacecraft. The capability to “power up” the flight fission system, while electrically integrated to the spacecraft to exercise the flight interfaces and systems, may not be necessary at a later time, but it is thought that the analogy to RPS operations should be considered here. The RPS systems are typically delivered after they have been fueled and tested; the heat source is already installed. This allows for a streamlined approach to ATLO, since the primary activities involve outfitting the RPS with the required flight hardware, conducting wellness checks of the power system and a hot fit check with the spacecraft. RPS are extensively tested prior to arrival at KSC and the testing continues once they arrive, either in a stand-alone configuration or integrated with the spacecraft. The checkout of a reactor system may require additional safety protocols, staffing, and facility accommodations beyond what a RPS typically requires.

The transportation of the two different types of systems would be very similar. The RPS and the core of the FPS dictate that the DOE Office of Secure Transportation (OST) would be involved. This type of transportation is usually scheduled approximately one year in advance and then finalized when the shipping date gets within 60 days. There are established data packages for either the RPS (9904, RTG shipping container) or HEU (ES-3100). Other packages may be necessary and may need to be explored, i.e., GE-2000 or NAC-LWT type B shipping container certified by NAC Corporation [82].

2.3.6.2 | Security Considerations

This topic of security consideration is covered in detail in Chapter 4 in this report. It is acknowledged here because of its potential importance in operations analysis, because the cost of providing security may affect where various activities take place (existing building versus a new one, for example). The results of the security analysis will be referred to here as the different options are considered.

The fact that NASA funds missions in a discrete project-by-project fashion may favor one approach over the other. The security posture must be reviewed and approved by NASA, DOE and the U.S. Air Force. The primary impact forecasted for spacecraft ATLO operations, resulting from additional security measures is believed to be primarily an increase in the schedule and the associated staff costs versus a typical RPS system. There were no obvious technical restrictions or constraints that appeared to be applied to spacecraft ATLO tasks resulting from the additional security layers imposed by an FPS.

2.3.6.3 | Operations Analysis

In an effort to be complete and to provide the most value going forward, NPAS considered a total of six options for delivery, integration, testing, and placement of an FPS onto a launch vehicle for a NASA space mission. Since it is likely that various assumptions that are considered for this study could change with time, the ATLO team decided a complete list of options and related assumptions, as well as a thorough analysis with the reasons for the down select to the most viable options, would have the most long-term value.

The initial assumptions include: (1) Extensive planning and preparations for the power system operations to support the mission ATLO would start approximately 5-6 years prior to launch; (2) The mission ATLO described here are only activities occurring at the launch site – assumed to be KSC for purposes of this study; (3) The FPS would be tested and its operational status verified prior to delivery to KSC; (4) Zero-power testing at KSC will be included to be minimally consistent with the RPS option; (5) All durations listed are notional and are best-case scenarios, with the first evolutions likely to be longer in length; and (6) Where integration operations “on the pad” are identified as an option, they shall be evaluated and compared against the existing “plug and play” integration criteria, similar to a RPS system. Cases where a re-design of the launch vehicle and/or other significant impacts to processing or hardware would be required are discussed or noted.

The options 2, 3, 4, and 5 considered are described in the NPAS Mission Studies report [76]. Details on the only two options that appear to be tenable (1 and 6) are described below.

Figure 2-5 shows the ATLO option 1 scenario. The HEU core and FPS would be shipped separately to KSC and delivered to the RTGF approximately six months prior to launch, which is analogous to an RPS timeline. The HEU core and FPS would be integrated and tested at the RTGF. Approximately two months prior to launch, the integrated FPS (HEU core and FPS) would be shipped to the PHSF and encapsulated with the spacecraft payload, inside the launch vehicle fairing. Approximately one month prior to launch, the encapsulated payload fairing assembly would be transported to the VIF and mated to the Atlas Launch vehicle. The ground-rule assumption for the ATLO analysis performed for this study was limited to the Atlas V launch vehicle, which includes references to the VIF and SLC-41. Approximately 1-2 days prior to opening of launch window, the Atlas V vehicle would be rolled out from the VIF via the Mobile Launch Platform (MLP) to the launch location (approximately 1,800 feet) at SLC-41.

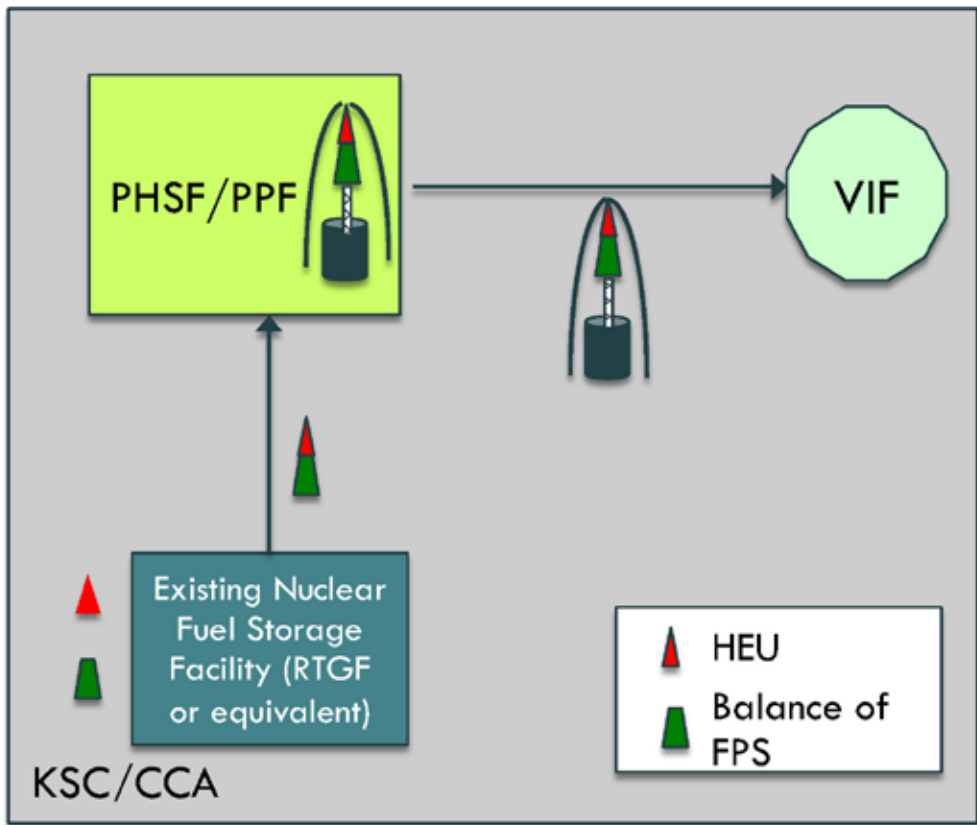

- Core and FPS shipped separately and received at existing fuel/FPS storage facility
- HEU Core integrated with power system assembly at existing fuel/FPS storage facility
- Zero power test performed at RTGF
- S/C payload stack/FPS encapsulated in fairing at PHSF
- Fairing S/C stack transported to VIF
- Lift to top of VIF and assemble onto the LV

FIGURE 2-5 | SUMMARY OF ALTO SCENARIO OPTION 1

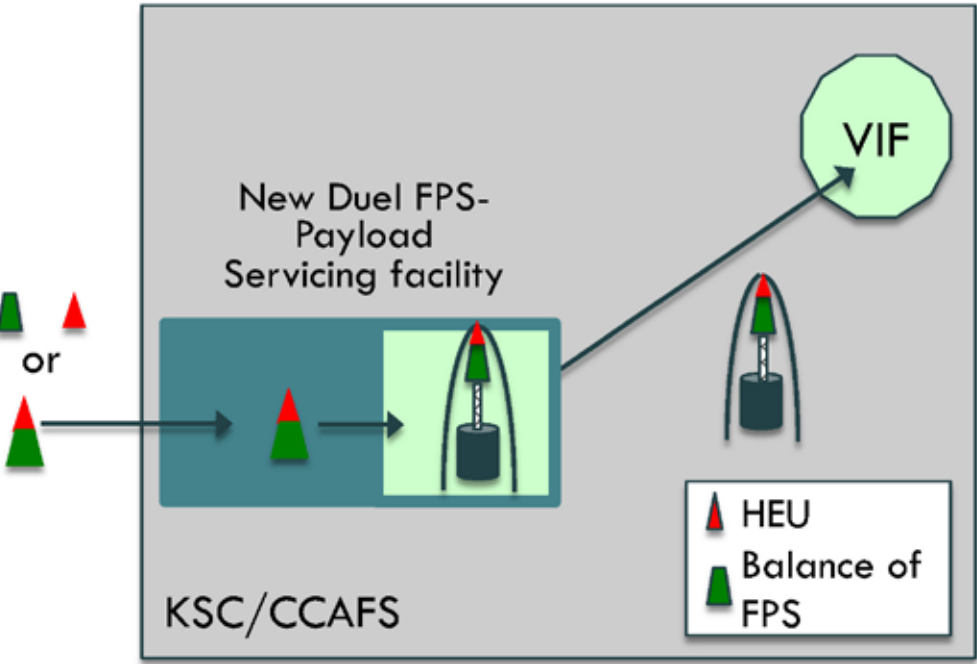

- Fueled or unfueled FPS received at new combined facility
- Core inserted into FPS if necessary
- Zero power check performed at New nuclear facility
- FPS and S/C payload stack integrated and encapsulated in fairing
- FPS and S/C stack transported to VIF and integrated on the LV

FIGURE 2-6 | SUMMARY OF ATLO SCENARIO OPTION 6

Figure 2-6 shows the ATLO option 6 scenario. The FPS would be delivered to a new nuclear facility that can serve the function of both the RTGF and the NASA PHSF. The HEU core and the FPS could be delivered separately or together, approximately six months prior to launch. The FPS would be tested in this new facility and then integrated onto the spacecraft. The payload fairing encapsulation process starts approximately two months prior to launch. When completed, the fairing would be transported to the VIF and mated to the launch vehicle approximately one month prior to launch. Approximately 1-2 days prior to opening of launch window, the Atlas V vehicle is rolled out from the VIF to SLC-41.

2.4 | Instrument Sensitivity Analysis

2.4.1 | Summary

The MST also assessed the impact on science instrument design and measurements arising from utilizing a spacecraft with an RPS or FPS. Radiation and neutron impacts on science instruments are of potential concern for FPS, in particular for instruments with optical detectors and instruments with high-voltage electronics. Noise from gamma rays from FPS would be on the order of magnitude of the Mars environment, and displacement damage from neutrons should be negligible. Total radiation dose could be mitigated with shield design, boom length, reactor operation duration, spot shielding, and through instrument robustness. RPS also produces gammas, but at a much lower level than FPS. Increasing the number of GPHS modules on RPS would be expected to increase the generated radiation proportionally. For example, the 16-GPHS ARTG would exhibit radiation fields 50-100 % higher than the 8-GPHS MMRTG. The effect of more GPHS modules is mitigated from strictly a linear relationship by some self-shielding effects. Note that the radiation field of a RPS is anisotropic due to the deviation of the heat sources from a point source geometry.

Though the new RPS and FPS would generate more heat per unit than the ASRG and MMRTG, thermal impact could generally be mitigated with shading and pointing if required by the mission or potential use of any excess heat could provide benefit for special thermal.

Vibration for a new SRG RPS and Stirling FPS is expected to be similar to the ASRG, and while this is expected to be low, it must be considered during spacecraft and instrument design.

EMI for a new RPS is expected to be low as for the current RPS, but it must be considered if there are sensitive instruments. For FPS, the impact on instruments would probably be minor due to greater separation distance between the reactor and instrument payload

2.4.2 | Objectives, Approaches, and Assumptions

The assessment of the impacts on science instrument design and measurement that arise from utilizing a RPS or FPS focused on the impacts of and mitigation strategies for radiation, thermal, vibration, pointing and fields of views, EMI, and magnetic fields.

The specific instrument packages from the UOP and TSSM mission concepts were analyzed in greater depth for their potential interactions with new RPS and FPS. The original TSSM and UOP concepts did not develop complete instrument performance requirements so typical measurement requirements were used where needed. Then, the general RPS and FPS environments were evaluated for potential impacts on broad classes of instruments.

The main focus of the design study was to determine if instruments could operate nominally with the FPS-based power system considering its higher radiation and thermal emission levels. The results are compared to those for RPS-based power system.

2.4.3 | Reference Radioisotope Systems

The RPS considered in this analysis were the 6-GPHS SRG and the 16-GPHS ARTG. The 6-GPHS SRG would produce 300 W_e EOM and 1,500 W_{th} BOL, and the 16-GPHS ARTG would produce 350 W_e EOM and 4,000 W_{th} BOL.

2.4.4 | Impact of RPS Implementations on TSSM and UOP Payloads

Instruments investigated require little or no changes to accommodate both RPS designs, ARTG and the new SRG. Payloads have been integrated with RTGs (which have higher levels of radiation than the RPS) on, for instance, Voyager, Ulysses, Cassini, and (Pluto) New Horizons. Note that these missions accommodated the RTGs on a boom, and utilized heat shields to protect the payload from viewing the hot power source.

No significant changes in instrument impacts would be anticipated with a new SRG or ARTG relative to current ASRG and MMRTG designs.

As larger units, they would produce more radiation and heat per unit, and potentially more vibration and EMI, but at a given power level total impact is expected to be similar. As system designs mature, more investigation may be warranted.

2.4.5 | Reference Fission Systems

The two notional FPS designs considered in this analysis were the 1-kW_e SRG generator FPS (4.3 kW_{th}) and the 1-kW_e TE FPS (13 kW_{th}).

The FPS design would use a Uranium-Molybdenum (UMo) reactor core, with a truncated-cone, shadow shield with layers of lithium hydride (to shield neutrons) and depleted uranium (to shield gamma rays), as described in Section 3.5 Design Reference Fission Power Systems.

The FPS studied were designed with radiation requirements of 1×10^{11} neutron (Figure 2-7) and 25 krad of gamma rays behind 100 mils of aluminum (Figure 2-8) at a 10-meter dose plane over 15 years. These correspond respectively to fluxes of 200 n/cm²-s and 0.2 Rad/hour of gamma radiation.

Total radiation dosage experienced by the instruments is the sum of the FPS component (baseline 25 krad) and the environmental component (varies by mission). Instrument parts are typically designed with a Radiation Design Factor (RDF) of 2, so if radiation dose from FPS is 25 krad, and radiation dose from environment is also 25 krad, then instruments would need to be designed for $(25+25) * 2 = 100$ krad tolerance.

Vibration and EMI estimates were not developed for the FPS, so it was assumed that vibration and EMI from the Stirling FPS convertors are similar to an equivalent quantity of ASRGs.

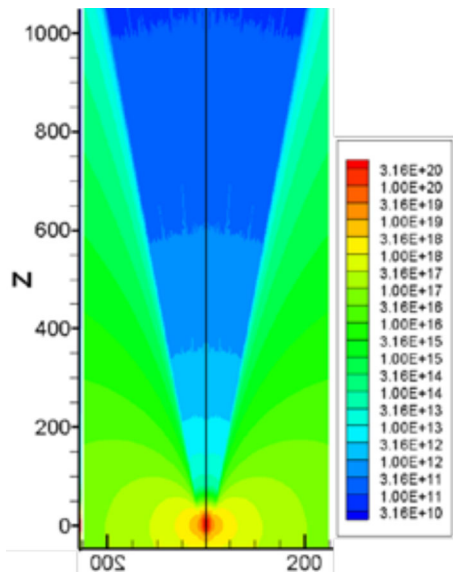

FIGURE 2-7 | NEUTRON DOSE OVER 15 YEARS, OUT TO 1,000 CM

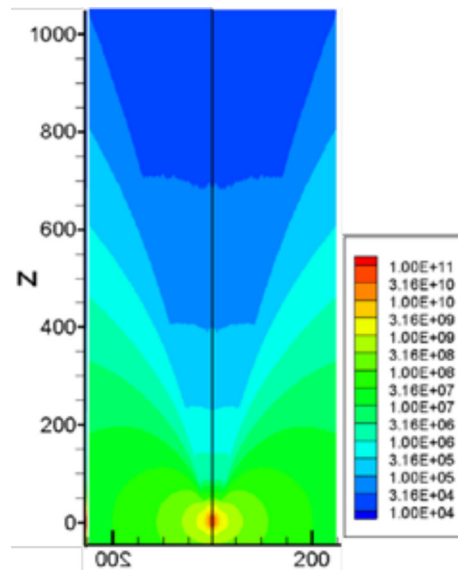

FIGURE 2-8 | GAMMA DOSE OVER 15 YEARS, OUT TO 1,000 CM

2.4.6 | Impact of FPS Implementations on TSSM and UOP Payloads

2.4.6.1 | NPAS TSSM Study

Figure 2-9 shows the NPAS notional FPS spacecraft layout. Utilization of a FPS would require additional design to address the effects of gamma and neutron radiation. The primary approach could be shielding – a low-Z (LiBr) shield wrapped around the reactor to intercept neutrons and a high-Z (W) shield beneath the reactor to reduce the flux of gamma radiation to the spacecraft. A 10-meter boom could be added to reduce the radiation by $1/r^2$. Waste heat is dissipated in the (blue) radiator panels on the boom. For this spacecraft, which uses solar panels to power SEP, the reactor could be kept quiescent (~ 0 radiation) for most of the cruise phase – further reducing the total dose from the reactor. Most instruments and electronics would be mounted 13 meters from the reactor, and receive ~ 12 krad from FPS gamma radiation after 8 years. The Polymer Mass Spectrometer (PMS) would be located nine meters from the reactor in order to meet field of view (FOV) requirements, and would receive ~ 25 krad from FPS gamma radiation after 8 years.

The total fluence of neutrons over 8 years would be $\sim 5 \times 10^{10}$ n/cm² at 13 meters and $\sim 10^{11}$ n/cm² at 9 meters. The neutrons have a negligible impact on total krad dose.

The additional environmental radiation would be estimated at 7 krad, for a total of 19 krad for most instruments and 32 krad for PMS. These values would be doubled to 38 krad and 64 krad with an RDF of 2, well below the 100-krad dose requirement.

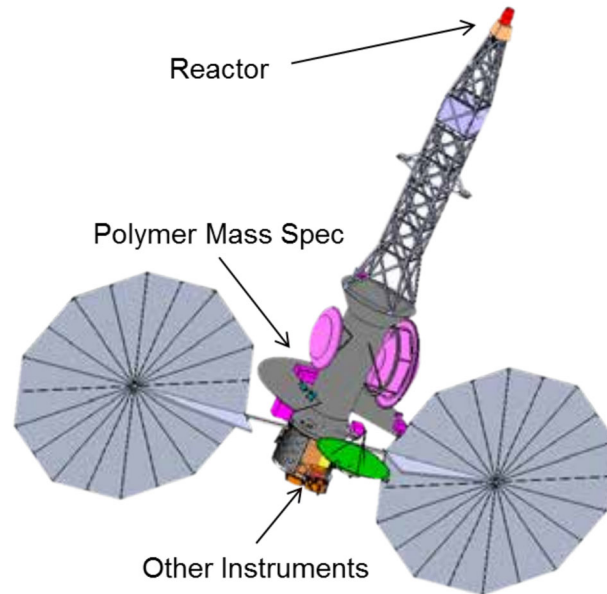

FIGURE 2-9 | NPAS TSSM STUDY NOTIONAL FPS SPACECRAFT LAYOUT

2.4.6.2 | NPAS UOP Study

The UOP spacecraft was not redesigned to accommodate an FPS during the NPAS. However, it is assumed that the redesign would include a 10-meter boom and a shielding and thermal control approach similar to that used for TSSM. It is also assumed that the FPS would be placed 180 degrees away from the probe, requiring relocation of the antenna. Thus, the primary differences between the UOP and the TSSM missions with respect to the impacts of the FPS on instrumentation are: (1) a slightly longer mission duration (14 years), (2) no solar panels to mitigate the effective radiation dose by delaying reactor activation, and (3) distance of the payload from the FPS. It is assumed here that the payload would be located at 10 meters from the power source – thus the total gamma ray dose for the payload is 25 krad and the neutron dose is 10^{11} n/cm². The environmental dose would be estimated to be 10 krad, yielding a mission radiation dose at the payload of 35 krad. This value would be doubled to a total of 70 krad with an RDF of 2.

2.4.7 | Environmental Impact of Nuclear Power System Implementations on Payloads and Mitigation Strategies

2.4.7.1 | Radiation

Both RPS and FPS systems are significant sources of radiation and could have significant impact on the payloads and measurement by payloads. The RPS emits alpha particles, which are easily shielded, but is also a source of gamma rays and neutrons, which can be significant to payload sensors and electronics. A FPS also emits neutrons and gamma rays, but with much greater fluences.

The effects of the radiation on payload include damage to electronics and sensitive surfaces, increased noise on the sensors, and, potentially, complicating measurement of the pristine in situ environment by adding energetic electrons, ions, and neutrons (and positrons from FPS from pair-production by energetic gamma rays).

For a notional straw-man mission, the FPS reactor would be activated once it is safely away from the Earth after launch and the total ionizing dose (TID) received at the payload from an FPS would be approximately 25 krad over 15 years, which could be approximately equal to the environmental dose for a mission of that duration. If so, the total dose would be 50 krad. Considering a RDF of 2, the payload must be designed to

withstand 100 krad. Commercial-off-the-shelf parts can be as soft as 1 krad, and may be impractical for use with either RPS or FPS systems.

Note that a gamma dose rate of 25 krad over 15 years is lower than the dose seen for Mars missions. The noise from gamma rays is proportional to dose rate, and thus the noise from the reactor should be similar to the noise seen on solar-powered Mars missions. The neutron flux rate corresponds to a total dose of $\sim 1 \times 10^{-3}$ krad over 15 years, suggesting that displacement damage from neutrons would pose a negligible risk to the payload.

The radioisotope generators could have a small effect on measuring the pristine in situ environment, other than the induced instrument noise discussed above. Spacecraft charging effects are not significant with standard practice designs. Neither gamma rays nor neutrons become trapped and concentrated in spacecraft or planetary fields. They can interact with in situ neutral and charged species, but the cross sections (and local densities) are so low that the changes to the environment are difficult to detect.

At 25 krad, all instrument types experience minor issues with radiation tolerance of signal-chain components that limits the ability to reuse existing designs. At 50 krad, all instrument types experience significant issues with component radiation hardness resulting in performance compromises and increased cost.

There are several mitigation strategies to ameliorate the effects of RPS and FPS radiation on instruments. Separation would be a very effective strategy as radiation decreases as r^2 , but the design becomes challenging when separation distances exceed a few meters. Nevertheless this is a primary strategy for FPS radiation mitigation, and trades between radiation dosage and boom mass, configuration, moment of inertia, launch vehicle integration issues, and deployment complexity must be considered for a specific mission implementation.

Incorporation of an effective shadow shield could reduce radiations from FPS, typically a trade between mass and effectiveness. Spot shielding around soft components could be very effective for the shielding from energetic particles (Galileo used kilograms of tantalum for this purpose) but would not be very effective for shielding from gamma rays. As mentioned above, activation of the FPS could be delayed, reducing the total mission dose.

SEU-type events could be mitigated with error correction codes, and, for detectors, with spike-detection and removal. Spike detection could be challenging, since there is a continuous distribution of the amplitude of the spikes. In general, spike removal techniques utilize higher sampling rates and/or larger data volumes and greater acquisition times.

Displacement damage in detectors could be corrected with thermal annealing. Many instruments have flown annealing heaters, but they are rarely used—both because of risk to the detectors (such as damage to solder joints or bump bonds) and of to changes in the “flat-field” calibration.

Micro-channel plates amplify noise events with electron cascades, potentially reducing the lifetime of the detectors. Faraday cone detectors are less sensitive to radiation effects.

2.4.7.2 | Thermal

The thermal outputs of the notional nuclear power systems considered are listed in Table 2-7. Instrument radiators would need to be shielded from view of the power system radiators. Most optics would require blanketing or shielding to avoid distortion arising from differential heating. For RPS systems, the radiated power adds to complexity of the launch configuration. FPS systems would not produce heat until they begin operation.

TABLE 2-7 | THERMAL WASTE HEAT FROM THE NPAS POWER SYSTEMS [TOTAL HEAT/WASTE HEAT]

6-GPHS SRG	16-GPHS ARTG	1 kW _e Stirling FPS	1 kW _e TE FPS
[1.5/1.15] kW _{th}	[4.0/3.55] kW _{th}	[4.3/3.3] kW _{th}	[13/12] kW _{th}

Heating from the Stirling FPS would be approximately twice the ~2 kW_{th} of current existing RPS (i.e., MMRTG). We have found no reports in the literature of this waste heat having a measurable effect on orbital in situ measurements.

Certain sensitive instruments (e.g. IR spectrometers, thermal spectrometer, and other instruments requiring cooling) would need to be pointed away from the FPS end of the spacecraft and shaded. Given that the heat from the power source is all coming from a known direction it should be possible to find clear fields of view for the radiators.

In general, spacecraft design could resolve thermal issues with standard practices of pointing and shading.

2.4.7.3 | Vibration

Stirling convertor tests and the interface specifications for ASRGs show vibration levels that are well within typical spacecraft environmental specifications and thus should not be an issue for heritage instruments. There are residual concerns about operation in unbalanced mode (partial Stirling failure) and in possible higher vibration levels in the higher power Stirling engines required for the SRG and FPS implementations. Further design maturation and analysis is needed to quantify these vibration levels.

The magnitude of vibration impact is a strong function of the separation distance between the vibration source and the sensitive area, with a less than perfectly stiff structure soaking up much of the vibration.

In general, vibration issues could be accommodated using standard engineering practices. For FPS spacecraft, it would be important that the boom be designed to damp vibration and avoid resonance.

2.4.7.4 | Pointing and Fields of View

The nuclear power systems add restrictions for the fields of view of instrument radiators and optical axes – but generally are not as intrusive as solar arrays. The 10-meter boom would affect the inertial and dynamic properties of the spacecraft. It may be extremely difficult to damp some bending modes and the spacecraft may not be very agile for some rotations. These may combine to lead to requirements for a scan platform or fast-steering mirror for remote sensing instruments and may introduce challenging periodicities in alignment for the in situ instruments.

Larger reaction wheels, a scan platform, or fast-steering mirrors could resolve issues with spacecraft agility for pointing remote sensing instruments. Normal spacecraft engineering practices would be expected to resolve issues for fields of view.

2.4.7.5 | Electromagnetic Interference (EMI)

No EMI issues have been identified for nuclear power systems that lie beyond normal environmental specifications although there is still concern about fields that may be generated by Stirling engines, particularly operating in unbalanced mode. Studies for nuclear propulsion have shown that fission sources are no more problematic than spacecraft charging due to the space environment. Additionally, flight experience from past missions shows that use of RTGs and similar RPS systems do not lead to large charge imbalances.

EMI varies with distance as 1/r² so separation is an effective strategy. For example, in the case of the TSSM notional FPS spacecraft design, compared to the notional RPS spacecraft design, the distance between the Stirling convertors and the instruments would be tripled, so EMI from the power system would be 9 times less in the FPS case than in the RPS case.

2.4.7.6 | Magnetic Fields

The RTG on Galileo created less than 1 nT at the payload. The current trend for payload magnetic requirements is an order of magnitude more stringent, 0.1nT at the magnetometer. ASRGs, operating in balanced mode, are rated to meet this requirement. However, magnetic cleanliness for unbalanced operation or with larger Stirling engines remains to be verified. No magnetic cleanliness issues have been identified for the fission power sources although that may be in part due to the immaturity of the design and testing. The cooling loop, for instance, could be a source of magnetic fields, depending on the implementation.

Normal spacecraft engineering practices such as using twisted pairs of wires would be expected to resolve issues with unbalanced current loops.

2.5 | Power Needs Assessment for NASA Missions

2.5.1 | Summary

NASA HEOMD and SMD have a variety of power needs for their missions. Potential HEOMD power demands tend to be much higher than potential SMD needs, reaching into the tens of kW_e range, potentially favoring a larger-sized, lower dollars-per-kilowatt FPS unit. Human lunar and Mars missions could benefit from a FPS that is easily scalable to 10 to 40 kW_e. This is the power range required for a Mars surface power system.

Past outer planet science mission concepts have been designed to the constraints of available power systems. Previous missions have had power requirements that ranged from 100 W_e up to ~1,000 W_e, i.e., Mars Science Laboratory to Cassini.

Based on the science mission class power needs assessment results, Discovery, New Frontiers, and Flagship missions could all be supported by an RPS unit size of ~300 W_e at EOM.

Discovery missions could use one unit, New Frontiers missions could use two units, and Flagship missions could use 2-4 units. High-powered Flagship missions might use FPS in the 1+ kW_e range.

It is recognized that the understanding of roles of the nuclear power systems in mission development and operations phases could strongly influence the nuclear power system technology development and maturation approaches.

2.5.2 | Objectives and Approaches

This effort examined past, present, and future power needs of NASA missions for the Science Mission Directorate and Human Exploration and Operations Mission Directorate to understand Science and HEOMD mission pull for RPS and FPS. Furthermore, considerations for science mission class constraints on RPS such as cost, mass, and power, and FPS applicability to those missions were undertaken. Also, the Mission Study Team investigated unit sizing for each science mission class to identify overall optimal power unit sizing. The Mission Study Team also analyzed the nine DSMCE studies, past Discovery Missions and mission concept studies supporting the most recent decadal survey including TSSM and UOP RPS/FPS studies as well as mission and power system technologies.

For HEOMD missions, MST relied primarily on the previous Mars DRA 5.0 study and some recent HEO Architecture Team study updates as a basis for the HEOMD preliminary nuclear power needs [20–22].

2.5.3 | HEOMD Missions

HEOMD currently has no approved missions requiring nuclear power systems. The primary future need would be a crewed Mars surface mission, such as that outlined in Mars DRA 5.0 [22]. Recent studies have validated potential Mars surface power needs at 35 to 40 kW_e, with Mars Ascent Vehicle (MAV) propellant production and crew habitat support being the principal drivers. Previous trade studies rejected solar power for this application because it limits propellant production to daylight hours (thus extending the overall mission timeline), and the possibility that power disruption due to months-long dust storms pose an unacceptable crew safety risk. Note that once the investment in a relatively large fission surface power system is made, there is likely no further need for smaller RPS; surface rovers or other portable equipment could be recharged with the fission system.

Because a Mars surface power module could become a workhorse power system for NASA, and it is unlikely that NASA will develop more than one fission surface power system due to limited future NASA budgets, it is important that both the initial and immediate future power needs, and associated overall FPS cost and affordability, are understood. Recent studies indicate that a modular approach employing multiple, small (3 to 10 kW_e) reactors may have potential mass and operational advantages over a single, large (40 kW_e) reactor system; however, the total power costs for the Mars crewed surface missions and campaigns that use many smaller, higher dollars-per-kW_e FPS units could become cost prohibitive and unaffordable. Additional reactor trade studies, analyses, and system integration assessments, as well as development of nuclear safety requirements and policies for Mars surface operations with human presence nearby (either while operating or in the future), which currently don't exist, would be needed to understand better potential FPS development, design and cost issues. Also, the Space Technology Mission Directorate's (STMD's) KiloPower feasibility activity, further studies with DOE and industry, and a non-advocate review all would need to be completed before deciding on a final power system concept and size for crewed Mars surface missions.

Finally, exact Mars human-system architectures have not yet been determined and could significantly alter nuclear system needs for future crewed Mars surface missions. Details of desired attributes and capabilities that are expected to be necessary for a FPS intended for crew use on the Martian surface as well as other conclusions concerning power needs for HEOMD missions can be found in the NPAS Mission Studies report [76].

2.5.4 | SMD Science Missions

SMD science missions are discussed here focusing on the Discovery, New Frontiers, and Flagship mission classes. Each of these mission classes has different constraints regarding cost, mass, and power. Discovery missions tend to be lower-powered missions and are severely limited in cost, and thus generally would be relying on RPS-related costs not being included in the mission cost cap. New Frontiers missions are also cost constrained, but mission studies have demonstrated they could budget for RPS flight unit and launch approval costs, though not necessarily DOE and fuel costs. Flagship mission concepts are generally very challenging missions with higher payload power needs and a significantly higher cost cap that can better accommodate RPS, launch approval, DOE, and fuel costs.

Upon assessing the past, present, and potential future SMD mission set, it is observed that a single unit size producing ~ 300 W_e at end of mission could be the power level of most interest for future RPS development efforts.

This ~300 W_e size satisfies the desire to minimize the number of installed units for higher-power Flagship missions, with three to four units to satisfy a 900-1,200 W_e spacecraft. At the lower power end, (non-lander, non-rover) Discovery missions, could amply be powered with one single ~300 W_e unit. New Frontiers missions could then be powered with one or two units. This observation held true for >90% of the missions analyzed for this study.

Details of these conclusions for the Discovery and Flagship Mission Classes can be found in the NPAS Mission Studies report [76].

Observations and Perspectives on Single Unit RPS Size for Science Missions

Figure 2-10 summarizes the Mission Study Team’s observations of SMD missions. With a perspective of what unit size power system should NASA invest in that would be larger than the current ~110-W_e MMRTG, the motivation, to some degree, is to identify a size that could satisfy the three classes of SMD missions with the minimal number of units. First and foremost, RPS typically mass optimize at larger power sizes, realizing an economy of scale. Heat loss is higher at either end of a RTG (where there are no TE converters to convert it to electrical power); therefore, units with a higher number of GPHS modules have a lower percentage of heat losses, maximizing electric power output. In addition, basic structural mass is of a higher percentage in smaller size units.

Moreover, the matter of designing a spacecraft bus to accommodate a greater number of RPS units becomes increasingly difficult in arranging instruments, antennas, etc., while maximizing the RPS radiator’s view of space in order to maximize heat rejection. Secondly, integrating a larger number of units at the launch site is somewhat limited by several factors; a reasonable number of launch vehicle fairing access doors, and if using the Atlas launch vehicle, workable flooring access is not readily available around the entire vehicle at the integration facility.

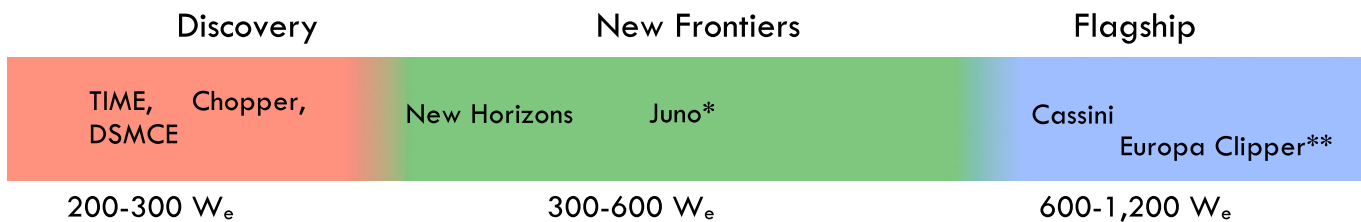

* Non-RPS mission

** NASA has selected solar power as the current notional baseline for the Europa Clipper mission after the NPAS study was concluded

FIGURE 2-10 | REPRESENTATIVE POWER RANGES FOR SMD MISSION CLASS

Upon assessing the past and potential future SMD mission set, it was observed that a single unit size producing ~ 300 W_e at end of mission could be in the area of interest for future RPS development efforts. This size satisfies minimizing the number of installed units for higher power Flagship missions with three to four units to satisfy a 900- to 1,200 W_e spacecraft. At the lower power end, Discovery missions, could amply be powered with one single ~300-W_e unit. New Frontiers missions could then be powered with one or two units.

Another perspective on determining unit size is what mission class has the most need for RPS. While more Discovery missions are executed than NF or Flagships, the cost cap of \$450 million makes it more difficult to implement a challenging mission that would be enabled by an RPS. Being a competed mission, the cost associated with proposing a RPS mission, purchasing the RPS unit(s) and associated launch approval costs, becomes a significant budget challenge if these costs are included in the cost cap. New Frontiers, with a larger \$750 million cost cap, could more easily be conceived to conduct a challenging mission that is truly

enabled by RPS. Flagship missions are flown on a much longer cadence, but are also the most capable and challenging missions.

Given that, using multiple $\sim 300\text{-}W_e$ units should fully satisfy Flagship needs and would still be desirable for NF and Discovery missions.

2.6 | Transition Point between RPS and FPS for Science Missions

2.6.1 | Summary

The power level of the transition point between RPS and FPS for science missions is subjective and mission dependent. MST identified and discussed three major discriminators: plutonium fuel availability, power system mass, and power system cost impact. MST's analyses using those discriminators found a prudent general transition point around 1 kW_e . This power level could be achieved by following a Cassini-heritage model for plutonium fuel consumption ($\sim 32\text{ kg}$ of plutonium dioxide) and number of RPS units flown (three GPHS-RTGs = 900 W_e); this would be the approximate transition point for power system cost impact.

2.6.2 | Objectives

The purpose of the transition point analysis between RPS and FPS for science missions is to determine FPS applicability to science missions by answering questions such as: *Where does FPS come into play for SMD missions? At what point does it make sense for SMD to explore seriously the use of FPS?*

2.6.3 | Estimate of Potential Total Power Available from Plutonium

This section provides a prediction of the total quantities of fueled clads and GPHS modules that could be fueled with Pu-238 that could be produced using domestic sources of target materials. This section provides the technical analysis illustrating that the DOE has available sufficient raw fuel material required to produce plutonium in order to meet the NASA mission needs as stated in this study. Sections 3.6.2 to 3.6.4 provides a projection for RPS availability and its impact on mission power by using various scenarios involving varying rates for production of new Pu-238, representative types of RPS, and several mission scenarios. The referenced RPS were defined to be the 16-GPHS ARTG and the 6-GPHS SRG. For the sake of this analysis, it is assumed that Mars 2020 (1 MMRTG), Europa (5 MMRTG) and a Discovery class mission (1 MMRTG) would entirely consume the current stocks of Pu-238. If any of these assumptions change, this prediction should be revisited; this is particularly true if NASA chooses a different power production means for the notional Europa mission.

With the quantities of neptunium that are available ($\sim 300\text{ kg}$) [83] and the assumption that we would use the current baseline production rate of 1.5 kg per year of plutonium oxide, this feed material would last several decades ($\sim 200\text{ years}$). The 2001 NEPA EIS for Pu-238 production allows for production up to a level of 5 kg per year of Pu-238 isotope ($\sim 7\text{ kg}$ year of oxide) at the facilities considered in the EIS, including the facilities at ORNL. [84] The consideration of a higher production rate at ORNL, which would have to be based on NASA demand, has previously been envisioned and would lead to the use of the existing stores of neptunium in a time frame of $\sim 60\text{ years}$ (see Chapter 5). The costs to increase the production rate will be determined upon request by NASA to DOE.

Additional Pu-238 could be produced from the Am-241 present in the weapons stockpile to be processed at the mixed oxide fuel (MOX) fabrication plant, currently under construction at the Savannah River site [85,86]. This scenario is different than that currently being pursued in the United Kingdom for the ESA, where the effort to extract Am-241 from a stockpile of plutonium that was set aside from the reprocessing of commercial spent reactor fuel for direct use as heat source material, as opposed to use as a target material to produce Pu-238. The ability to use Am-241 as a target material for production of Pu-238 is established and documented [87] as is the chemistry to separate the Am-241 [88]. The production of Pu-238 from Am-

241 has Cm-242 as an intermediate product, which has its own history as a potential heat source [89]. The separation of Am-241 and subsequent conversion to Pu-238 could produce a minimum of 300 kg of Pu-238 based on the quantities of weapons material to be processed at the MOX plant as mentioned in the NEPA action (34 tons of weapons plutonium [90]). The use of americium as a target material would require additional target fabrication capabilities but the irradiation facilities and the separation facilities would essentially be the same as for using neptunium. The costs for the additional DOE target fabrication capabilities are not yet firmly established and would require additional investigation. The conservative amount of Pu-238 that could be produced from the current stores of US-owned neptunium is about 200 kg. The conservative total amount of Pu-238 from these two sources of target materials (Np-237 and Am-241) of 500 kg represents a quantity of isotope, which would roughly be equivalent to 685 kg of plutonium dioxide of appropriate isotopic assay for heat source production. The number of fueled clads produced from 500 kg of Pu-238 would, therefore, be 4,545. This would be used to produce 1,136 GPHS modules.

The purpose of presenting these projections here is to illustrate the technical feasibility of fuel production flexibility in meeting RPS needs: by producing more Pu-238 in addition to the possible use of more efficient power conversion systems. The costs for increasing the Pu-238 production rate to 5 kg per year of isotope and the cost to use Am-241 as target material would need further analysis outside this study.

For use by NASA and others, DOE has produced approximately 300 kg of Pu-238 over the last 50-plus years. NASA has consumed approximately 140 kg of this material with the rest going to other users or still in the national inventory. The potentially available Pu-238 discussed above is approximately 4 times what NASA has used over the last 50 years.

2.6.4 | Transition Point Analysis – Plutonium Fuel Availability

If there were shortage of the Pu-238 for NASA usage, this Pu-238 fuel availability could be an excellent discriminator for determining transitional point between RPS and FPS for science missions. Considering the amount of Pu-238 that could be used for NASA and the speculated science mission rates, the fuel availability as an input for the transitional point analysis became an irrelevant discriminator.

2.6.5 | Transition Point Analysis – Mass

RPS generally have higher specific powers than FPS at lower power levels, while FPS generally have higher specific powers than RPS at higher power levels. Examination of mass for RPS and FPS at various power levels can provide an approximate cross-over point for specific power and suggest a power level to transition from RPS to FPS based on system mass.

Table 2-8 lists the powers, masses, and specific powers for six different RPS and FPS conceptual designs.

Spacecraft can use multiple RPS units, with essentially constant specific power. Integration gets more complicated past 3-4 RPS units, so this is not an indefinitely extensible approach. Though only one size of SRG and one size of ARTG are included in the table, RPS specific power does increase slowly with system size due to economy of scale. Sparing methodology is not considered in this analysis.

FPS specific power increases significantly with system size, with Stirling FPS exceeding RPS specific power at the ~10 kW_e power level and beyond.

The powers and masses are plotted in Figure 2-11. The RPS values are plotted for up to 4 units.

From these data, it is clear that RPS is more mass efficient at the power levels where RPS is applicable. Extrapolating the RPS masses would give a cross-over point at the ~8-10 kW_e power level, assuming it was possible to accommodate a sufficient number of units and/or scale up RPS unit size [91].

TABLE 2-8 | SPECIFIC POWER FOR EXISTING RPS AND NPAS RPS AND FPS CONCEPTS

Class	Type	Power (W _e BOL*)	Power (W _e EOM**)	Mass (kg)	Specific Power (W _e /kg BOL)	Specific Power (W _e /kg EOM)
Existing RPS	MHW-RTG	157	89***	38	4.1	2.3***
	GPHS-RTG	290	227	58	5.0	3.9
	MMRTG	115	55	45	2.6	1.2
RPS	eMMRTG	154	101	45	3.4	2.2
	6-GPHS SRG	370	297	47	7.9	6.3
	16-GPHS ARTG	456	347	54	8.4	6.4
FPS	1 kW _e Stirling FPS	1,000	1,000	406	2.5	2.5
	5 kW _e Stirling FPS	5,000	5,000	1,049	4.8	4.8
	10 kW _e Stirling FPS	10,000	10,000	1,559	6.4	6.4
	1 kW _e TE FPS	1,000	1,000	604	1.7	1.7

* BOL is Beginning of Life: when the unit is fuelled, typically 3 years before launch for RPS.
 ** EOM is End of Mission defined as 17 years after fueling, typically 14 years of operation for RPS.
 *** MHW-RTG values come from Voyager data at 34 years of operation, rather than 14 years of operation.

Mass vs Power Level

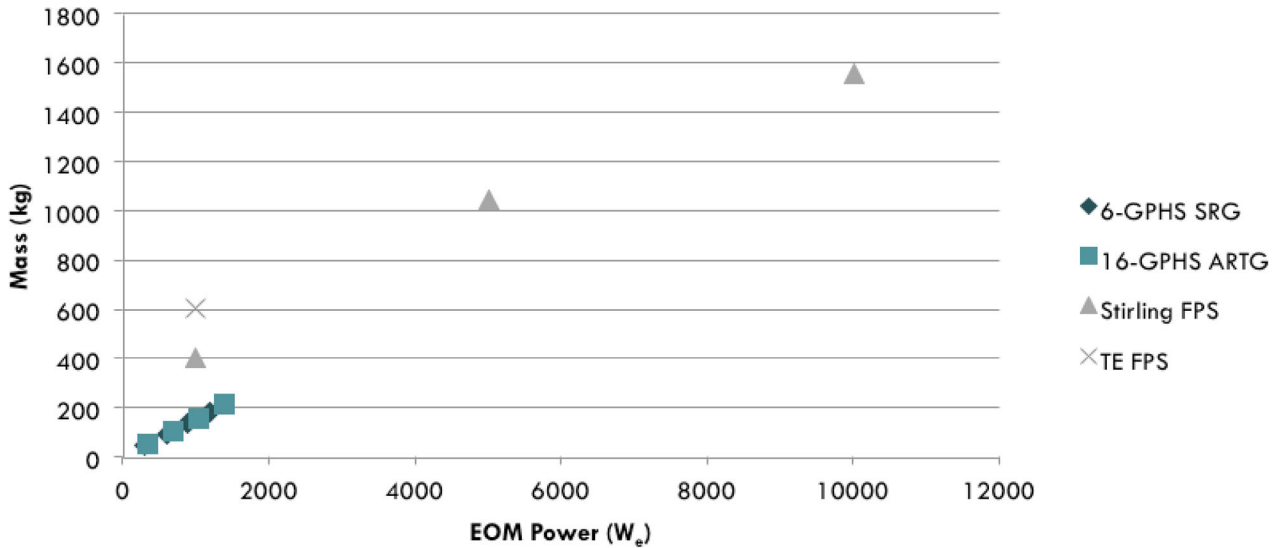

FIGURE 2-11 | NPAS RPS AND FPS MASS V.S. EOM POWER

2.6.6 | Transition Point Analysis – Cost

Examination of cost for RPS and FPS at various power levels can suggest a power level to transition from RPS to FPS based on system cost.

Estimated mission costs for new RPS and FPS are plotted in Figure 2-12. These costs include RPS unit costs, RPS-related ATLO costs, and launch services costs. These costs do not include any development costs or launch vehicles costs.

The RPS values are plotted for missions with 1 to 4 units. Power system production and fuel related costs scale with number of units; most other costs are constant with number of units.

Cost for the first unit is on the same order for both RPS and both FPS. Due largely to plutonium costs, as soon as there are multiple RPS units on a mission, the total RPS cost is higher than the cost for one FPS unit. Because the highly-enriched uranium fuel costs for the FPS were assumed to be zero, the FPS costs may be larger than indicated, but the cost increase with power is expected to be less for an FPS than for multiple RPS units. After cost deltas to non-nuclear mission costs are taken into account, this suggests that FPS is beneficial from a cost perspective above ~1 kW_e. Note that the fidelity of the RPS (some systems in TRL 9) costs is higher than those for the FPS (TRL 1-3).

Nuclear Power Cost vs Mission Power Level

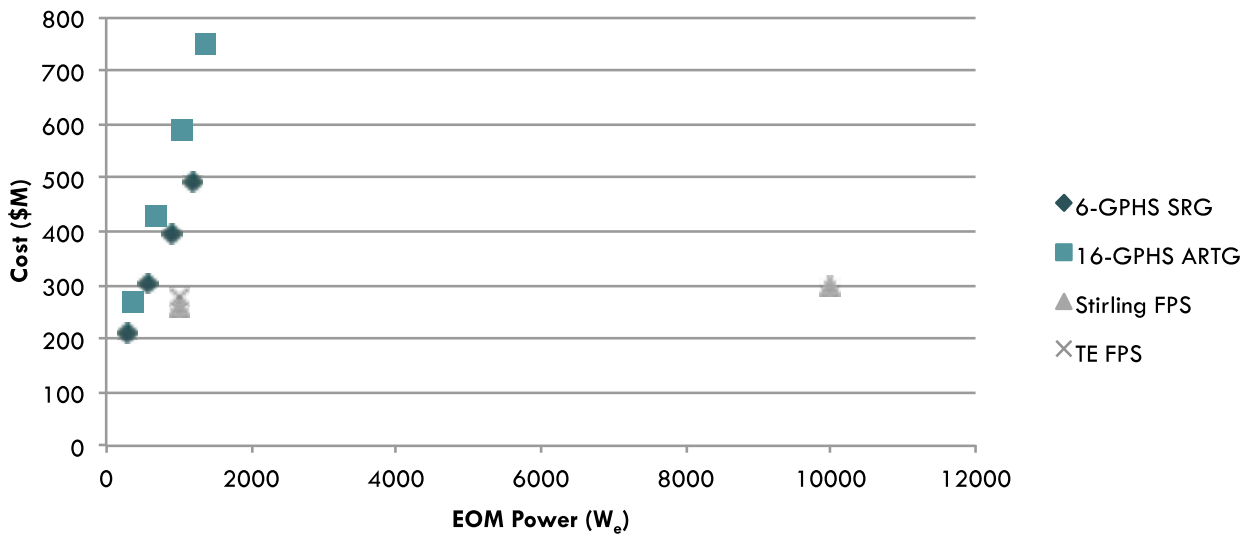

FIGURE 2-12 | NUCLEAR POWER COST V.S. EOM POWER FOR NPAS CONCEPTS

There is very little difference in estimated cost between the 1-kW_e and 10-kW_e Stirling FPS. In contrast, extrapolating the number of RPS units suggests that RPS costs would exceed Flagship mission total cost target before RPS could supply 10 kW_e. From a HEOMD perspective, the number of FPS units per mission is also an important cost consideration, particularly if several smaller 1-kW_e modular FPS units are assumed, which would suggest a total recurring FPS hardware cost of several billion dollars, which could cause the mission to become cost prohibitive and unaffordable.

2.7 | Mission Study Summary

The NPAS Mission Study Team conducted four major mission studies performed by JPL’s Team X, JHU/APL’s ACE Lab, and GRC’s COMPASS Team. The Mission Study Team also performed in-depth analyses in many supporting areas such as special FPS ATLO processes and security requirements, radiation environmental effects and mitigation options for payloads, and nuclear mission costs. In addition, an assessment and evaluation was performed on the Discovery, New Frontiers, and Flagship mission classes in order to capture a broader spectrum of power system needs and understand when nuclear fission systems are beneficial to missions.

To that end, many of the subtleties and nuances of this work are expressed in the expanded report [76], and the reader is encouraged to explore the findings discussed there in much greater detail.

3 | DESIGN REFERENCE SYSTEMS

3.1 | System Study Team Methodology

The System Study Team (SST) was chaired by GRC and comprised of subject matter experts from GRC, JPL, DOE, LANL, INL, ORNL, and Y12, along with an independent consultant (see Appendix. B). Effort was made to include technical experts from a variety of disciplines representing radioisotope heat sources, nuclear fuel, reactor design, radiation shielding, system testing, thermoelectric power conversion, Stirling power conversion, electrical controls, power electronics, and systems analysis. The primary objective was to develop and assess a limited set of power system concepts, as study options, beyond those that are currently available for future planetary science missions. While the main emphasis was on planetary science applications, and specifically the DRMs described in Chapter 2, the SST sought to include system concepts that could be extensible to HEOMD missions, such as a Mars crewed surface mission.

Technology readiness level is a key consideration in matching components and systems to missions. In reviewing options, the team considered a 20-year time horizon, from 2016-2036, for technology consideration. This limited the design space to those technologies that were already in development or were close derivatives of current space or terrestrial systems. Specifically, the SST sought to identify systems that build on the current MMRTG or recent ASRG developments while infusing new component technologies that would improve performance, reduce mass, reduce cost, increase robustness, or expand mission applicability. An important design driver was the identification of components or technologies that could be shared between RPS and FPS.

The study ground rules limited the power conversion trade space to include only thermoelectric and Stirling. RPS power conversion technology options have been studied in the past (e.g., [10,92,93]). Brayton and Rankine conversion are viable technologies, but do not appear to offer a performance advantage relative to Stirling at the power levels of interest. Brayton technology is receiving some attention by STMD and HEOMD for larger fission power and propulsion applications, and a current Phase II Small Business Innovation Research (SBIR) effort plans to develop a sub-scale 1 kW_e converter prototype [94]. The RPS Program has previously investigated thermophotovoltaic conversion technology, but the efficiency is less than Stirling and the technical maturity is less than thermoelectric. Alkali Metal Thermo-Electric Conversion (AMTEC) was carried as an RPS option during the late 1990s and found to have technical and performance issues that prevented its implementation. Thermionic conversion also lacks technical maturity and requires high temperature heat sources that don't appear feasible in the mission timeframe of interest.

The system concepts that resulted from the study, termed design reference systems (DRSs), were heavily influenced by the TSSM and UOP DRMs. The NPAS System and Mission Study Teams participated in an iterative process where requirements were defined, concepts were developed, and mission impacts were assessed. The SST started by generating parametric design options using variable heat source configurations to achieve a range of system electrical power output levels. The tabular options were provided to the Mission Study Team to assist in their mission analysis process. The mission studies were geared to consider variations on the original decadal survey studies that would produce expanded spacecraft capabilities with increased power. After the Mission Study Team finalized their design choice, the SST further defined the DRS characteristics and key performance parameters. These DRSs were then evaluated for their extensibility to smaller Discovery and New Frontier mission classes, and larger power systems that may be suitable for HEOMD Mars crewed surface missions. HEOMD mission requirements, nuclear safety criteria, and cost constraints have not yet been established, and additional assessments would need to be performed later to ensure that the reference FPS can meet HEOMD's mission needs.

3.2 | Parametric Systems Analysis

The initial product from the SST included a parameterized set of RPS and FPS concept options that spanned the TSSM and UOP mission design space. The RPS options included an Advanced RTG (ARTG) and a Stirling Radioisotope Generator (SRG). The ARTG option set, shown in Table 3-1, spanned a range of GPHS modules from 8 to 18. The ARTG parametric analysis was based on the use of segmented skutterudite, $\text{La}_{3-x}\text{Te}_4$, and Zintl thermoelectric (TE) couples being developed by the RPS Technology Advancement Project (TAP) under the Advanced Thermoelectric Couple (ATEC) task [95]. The analysis assumed a vacuum-only generator approach, similar to heritage GPHS-RTG technology, with radiatively coupled TE couples (or multi-couple modules) and high temperature multi-layer insulation (MLI) to achieve hot-junction temperatures of approximately 1300K [13]. Cold-junction temperatures of 498K were selected to achieve designs that are near the minimum system mass. The performance estimates included Beginning of Life (BOL) power (assumed as three years before launch), Beginning of Mission (BOM) power, End of Mission (EOM) power (assumed as 14 years after launch), and various other system design parameters as requested by the Mission Study Team. The ARTG option set covered BOM power levels from about 208 W_e to 491 W_e and EOM power levels from 166 W_e to 393 W_e . The TSSM mission study resulted in a decision to use three 16-GPHS ARTGs supplying 347 W_e EOM per generator. The UOP mission study resulted in the decision to use two 9-GPHS ARTGs supplying 189 W_e EOM each. The ARTG EOM system efficiency for the range of options considered was between 9.5% and 10%. System specific power varied from about 7.5 W_e/kg to 8.5 W_e/kg (based on BOL).

A similar parametric analysis was performed for the SRG option, with the results shown in Table 3-2. The SRG option considered a range of GPHS modules from two to eight, resulting in BOM power levels from 126 W_e to 492 W_e and EOM power levels from 104 W_e to 409 W_e . The SRG analysis assumed an “ASRG-like” dual-opposed Stirling convertor configuration with one-half the GPHS modules dedicated to each convertor [96]. The SRG analysis also assumed the same 247LC heater head material and random fiber metallic regenerator as used in ASRG. However, the designs assumed a higher temperature version of the ASRG NdFeB alternator magnets, MLI instead of Microtherm HT, and water-based heat pipes for cold-end heat rejection. The design hot-end temperature matched the ASRG value of 1033K and cold-end temperature was optimized for minimum system mass. As an alternative to the minimum mass designs, SRG systems could have been based on maximum power output or maximum system reliability. The preferred SRG design strategy could be a subject of further study as the NPAS designs are refined. The TSSM mission study resulted in a decision to use three plus one 6-GPHS SRGs supplying 297 W_e EOM each (the spare generator is provided for redundancy, and is therefore included for mass and cost, but not in the total power available). The UOP mission study resulted in the use of two 4-GPHS SRGs supplying 193 W_e EOM per unit. The SRG EOM system efficiency ranged between 22% and 24%. System specific power varied from about 7.5 W_e/kg to 8 W_e/kg (based on BOL).

TABLE 3-1 | ARTG PARAMETRIC OPTION SET

# GPHS	8	9	10	11	12	13	14	15	16	17	18
CBE Inputs											
BOL Power (W_e) (4 K)	218	248	276	306	336	366	396	426	456	486	515
BOM Power (W_e) (4 K + BOL + 3 yrs)	208	237	263	291	320	349	377	406	434	463	491
EOM Power (W_e) (4 K BOL+17 yrs)	166	189	210	233	256	279	301	324	347	370	393
BOL Power (W_e) (270 K)	217	247	275	304	334	364	394	424	454	483	513
BOM Power (W_e) (270 K)	207	236	262	290	319	347	375	404	432	461	489
EOM Power (W_e) (270 K)	166	188	209	232	255	277	300	323	346	368	391
Degradation Rate	1.6%	1.6%	1.6%	1.6%	1.6%	1.6%	1.6%	1.6%	1.6%	1.6%	1.6%
Housing Diameter (cm)	20.3	20.3	20.3	20.3	20.3	20.3	20.3	20.3	20.3	20.3	20.3
Radiator Fin Tip-to-Tip Dimension (cm)	51.5	51.8	52.1	52.3	52.6	52.9	53.2	53.5	53.7	54.0	54.3
Length	58.7	64.7	70.7	76.7	82.7	88.8	94.8	100.8	106.8	112.8	118.8
GPHS Heat Load (BOL W_{th})*	2,000	2,250	2,500	2,750	3,000	3,250	3,500	3,750	4,000	4,250	4,500
GPHS Heat Load (EOM W_{th})	1,784	2,006	2,229	2,452	2,675	2,898	3,121	3,344	3,567	3,790	4,013
Thermal Efficiency	84.9%	85.9%	85.8%	86.5%	87.0%	87.5%	87.9%	88.3%	88.6%	88.9%	89.1%
BOL (W_{th}) Waste Heat (4 K)	1,782	2,002	2,224	2,444	2,664	2,884	3,104	3,324	3,544	3,764	3,985
TE Cold Junction Temperature (270 K)	498 K	498 K	498 K	498 K	498 K	498 K	498 K	498 K	498 K	498 K	498 K
Average Heat Rejection Temperature (4 K)	459 K	459 K	459 K	459 K	459 K	459 K	460 K	460 K	460 K	460 K	460 K
Average Heat Rejection Temperature (270 K)	472 K	472 K	472 K	472 K	472 K	473 K	473 K	473 K	473 K	473 K	473 K
Disturbance Force (@ 100 hz)	N/A										
BOL Specific Power (W_e/kg)	7.5	7.7	7.6	7.8	8.0	8.1	8.2	8.3	8.4	8.5	8.6
Mass (kg)	29.2	32.2	36.1	39.2	42.2	45.2	48.2	51.2	54.2	57.3	60.3
BOL Power Efficiency	10.9%	11.0%	11.0%	11.1%	11.2%	11.3%	11.3%	11.3%	11.4%	11.4%	11.5%
EOM Power Efficiency	9.5%	9.6%	9.6%	9.7%	9.8%	9.8%	9.9%	9.9%	9.9%	10.0%	10.0%

* Assumes 250 W_{th} per GPHS



Option that was used for the TSSM Team-X Study



Option that was used for the UOP ACE Study

BOL: Beginning of Life; BOM: Beginning of Mission; EOM: End of Mission

TABLE 3-2 | SRG PARAMETRIC OPTION SET

# GPHS	2	4	6	8
CBE Inputs				
BOL Power (W_e) (4 K)	130	240	370	510
BOM Power (W_e) (4 K + BOL + 3 yrs)	126	232	357	492
EOM Power (W_e) (4 K BOL+17 yrs)	104	193	297	409
BOL Power (W_e) (270 K)	116	215	331	456
BOM Power (W_e) (270 K)	113	207	319	440
EOM Power (W_e) (270 K)	93	173	266	366
Degradation Rate	1.16%	1.16%	1.16%	1.16%
Diameter (cm)	19	33	33	36
Length (cm)	50	45	65	95
GPHS Heat Load (BOL W_{th})*	500	1,000	1,500	2,000
GPHS Heat Load (EOL W_{th})	437	874	1,312	1,749
Controller Efficiency	90%	90%	90%	90%
BOL Waste Heat (4 K) (W_{th})	356	733	1,089	1,433
BOL Stirling Cold End Temperature (4 K)	420 K	450 K	450 K	430 K
Average Heat Rejection Temperature (4 K)	400 K	428 K	428 K	408 K
Average Heat Rejection Temperature (270 K)	440 K	468 K	468 K	448 K
Disturbance Force (@ 100 hz)	10 N	13.6 N	16.9 N	19.8 N
BOL Specific Power (W_e/kg)	7.5	7.5	7.9	7.9
Mass (kg)	17.3	32.0	46.8	64.6
BOL Power Efficiency	26.0%	24.0%	24.7%	25.5%
EOM Power Efficiency	23.8%	22.1%	22.6%	23.4%

* Assumes 250 W_{th} per GPHS



Option that was used for the TSSM Team-X Study



Option that was used for the UOP ACE Study

BOL: Beginning of Life; BOM: Beginning of Mission; EOM: End of Mission

The TSSM and UOP mission studies also considered FPS options. The reference reactor design was derived from the 2010 NASA/DOE Small Fission Power System Feasibility Study [80] performed as part of the NRC Planetary Science Decadal Survey [2]. That study evaluated power system design options for a notional 1 kW_e , 15-year long planetary science mission with technology that was extensible up to 10 kW_e . The reactor utilized a 93% enriched UMo core (cast in plates), Na heat pipes, BeO reflector, and B4C central control rod. Radiation shielding was based on multiple layers of LiH and tungsten (or depleted uranium) to limit reactor-induced radiation to less than 25 krad and 1×10^{11} n/cm² at 10 m separation distance. The reactor technology approach was deemed suitable for thermal power levels up to about 50 kW_{th} . It could be combined with segmented skutterudite, La_{3-x}Te₄, and Zintl TE couples to produce power levels from 500 W_e to 3 kW_e , or with ASRG-derived Stirling convertors to produce power levels from 1 kW_e to 10 kW_e . A notional development plan was devised for the 2010 system concept that could achieve a flight capability in approximately 10 years. The present STMD KiloPower Technology Development Project evolved from the 2010 Small FPS Feasibility Study. The KiloPower Technology Development Project uses a similar design concept as a reference for a nuclear-heated reactor demonstration test that will be performed at the Nevada National Security Site, Device Assembly Facility in approximately 3 years.

The parametric analysis for the FPS options is presented in Table 3-3. The main focus was on a 1 kW_e FPS for TSSM as an alternative to the multi-RPS architectures. Analysis was performed for both a TE-based and Stirling-based option, derived heavily from the 2010 Small FPS Feasibility Study. Additional parametric design options were provided for a 5 kW_e and 10 kW_e Stirling FPS that could be used in a Nuclear Electric Propulsion (NEP) variant for the UOP mission. The 1 kW_e TE system used a 13 kW_{th} reactor core and

TABLE 3-3 | NPAS FPS PARAMETRIC OPTION SET

FPS Parameter	CONVERSION TECHNOLOGY			
	1 kW _e TE	1 kW _e Stirling	5 kW _e Stirling	10 kW _e Stirling
BOM Reactor Thermal Power (W _{th})	13,000	4,333	21,667	43,333
BOM Net Power (200 K) (W _e)	1,035	1,045	5,225	10,189
EOM Net Power (4 K) (W _e)	995	1,008	5,031	9,767
Full Power Mission Life (years)	15	15	15	15
Overall System Length (cm)	394	302	584	710
Maximum System Diameter (cm)	187	105	131	146
Thermal Efficiency	90%	95%	95%	95%
Device Efficiency	9.8%	28%	28%	28%
Electrical Efficiency	90%	90%	90%	90%
BOM Reactor Heat Pipe Temperature (K)	1,100	1,100	1,100	1,100
BOM Power Conversion Hot-End (K)	1,050	975	975	1,000
BOM Power Conversion Cold-End (K)	525	475	475	500
BOM Waste Heat (200 K) (W _{th})	11,965	2,955	14,778	29,846
BOM Heat Rejection Temperature (200 K)	475 K	400 K	415 K	450 K
Radiator Area (m ²)	5.23	3.19	13.62	19.59
EOM Reactor Thermal Power (W _{th})	13,000	4,333	21,667	43,333
EOM Power Conversion Hot-End	1,005 K	930 K	930 K	955 K
EOM Power Conversion Cold-End	522 K	470 K	471 K	497 K
EOM Device Efficiency	9.5%	27%	27%	26%
EOM Waste Heat (4K) (W _{th})	12,005	2,996	14,993	30,315
EOM Heat Rejection Temperature (4 K)	472 K	395 K	411 K	447 K
System Mass (kg)	604	406	1,049	1,559
BOM Specific Power (W _e /kg)	1.71	2.57	4.98	6.54
BOM Power Efficiency	8.0%	24.1%	24.1%	23.5%
EOM Power Efficiency	7.7%	23.3%	23.2%	22.5%

SKD/La_{3-x}Te₄/Zintl TE modules that are distributed along the condenser section of the Na heat pipes. The reactor design limited BOM, TE hot-junction temperature to about 1050K, and the 5.2 m² radiator was based on a 525K BOM TE cold-junction temperature. The system specific power was approximately 1.7 W_e/kg (BOM) and the overall EOM system efficiency was about 8%. The 1-kW_e Stirling FPS used a 4.3-kW_{th} reactor core and eight 200-W_e Stirling convertors operating at 975K BOM hot-end temperature. The 3.2 m² radiator is based on a 475K BOM Stirling cold-end temperature. The 1 kW_e Stirling FPS specific power was approximately 2.6 W_e/kg (BOM) and the overall EOM system efficiency was about 23%. The 5 kW_e and 10 kW_e Stirling designs used a 21.7 kW_{th} and 43.3 kW_{th} reactor core, respectively. System specific power for the larger Stirling FPS was improved due to advantageous economies-of-scale associated with the reactor and shield, resulting in 5 W_e/kg at 5 kW_e and 6.5 W_e/kg at 10 kW_e. The required power level for the UOP NEP variant option was ultimately determined to be approximately 8 kW_e based on preliminary mission analysis. However, the 10 kW_e Stirling option was selected for the UOP FPS DRM due to its close proximity in size and available design details.

3.3 | Radioisotope Power Systems: State-of-the-Art

3.3.1 | Radioisotope Thermoelectric Generators (RTGs)

RTGs have been used in space for over 50 years with various heat source configurations and two distinct TE couple technologies. The historical RTGs used couples based on either the PbTe family or the SiGe family of thermoelectric materials [97]. SiGe-based thermoelectric couples were employed in the 160 W_e MHW-RTG to accomplish missions such as Voyager (operating since 1977) and the 300 W_e GPHS-RTG used on missions including Galileo (1989), Ulysses (1990), Cassini (since 1997), and Pluto New Horizons (since 2006). The RTGs that used SiGe-based TE converters were designed for vacuum-only operation, and operated with hot-junction temperatures of about 1273K. PbTe-based thermoelectric couples (including segmented variants with p-type Te-Ag-Ge-Sb, or TAGS) were used in the 30 W_e SNAP-19 RTGs for Pioneer 10 and 11 (1972 and 1973) and Viking I and II (1975) and the current MMRTG launched on Mars Science Laboratory/Curiosity in 2011 [81]. The RTGs that used PbTe-based TE converters were designed for operation in both vacuum and planetary atmospheres, with hot-junction temperature of about 810K. The MMRTG represents the current state-of-the-art. It uses eight GPHS modules to produce approximately 122 W_e BOM with a mass of approximately 45 kg (2.8 W_e /kg). As a first spinoff of the ATEC technology development, skutterudite thermoelectric couples are undergoing technology maturation by the RPS Program as a direct replacement for the PbTe/TAGS couples in the MMRTG. With the upgraded TE couples, the “enhanced” MMRTG (eMMRTG) would produce 154 W_e BOM (equivalent to 3.5 W_e /kg) with the same number of GPHS modules (i.e. 8) used for a MMRTG [98].

3.3.2 | Stirling Radioisotope Generators (SRGs)

Free-piston Stirling convertor technology has been under development for space use since the 1970s when this configuration was matured in laboratory testing, eliminating the need for mechanical seals and wet lubrication [99]. The current RPS class of Stirling convertors was started in the late 1990s with Infinia Corporation’s 55 W_e Technology Demonstration Convertors (TDC). Sixteen TDCs were produced by Infinia, and four remain on test at GRC with the fleet leaders (TDC #13 and 14) at over 87,000 hours. The Stirling Radioisotope Generator, or SRG-110 used two GPHS modules and dual, opposed TDCs to generate 116 W_e BOM with a projected mass of 32 kg (3.6 W_e /kg) [100]. In 2006, a decision was made to replace the TDCs with two Sunpower 80 W_e Advanced Stirling Convertors (ASC) installed in a modified SRG-110 generator housing. To date, Sunpower has produced 27 ASCs, including six flight-pathfinder E3 models that are operating at GRC. The longest operating engineering model convertor is the ASC-E2 #5 with over 29,000 hours. The Advanced Stirling Radioisotope Generator (ASRG) was projected to produce 140 W_e BOM with two GPHS modules and weigh 30 kg (4.7 W_e /kg) [101]. It was planned for use on two 2012 finalists for NASA’s next Discovery Program missions (Comet Hopper and Titan Mare Explorer) but neither was selected. The ASRG flight project was cancelled in November 2013 due to budgetary pressures within the Planetary Science Division that could not support the projected cost required to complete the project.

3.3.3 | Roadmap for Developing New RPS Technology

The RPS Program is pursuing technology development for both the TE and Stirling power conversion options under the Technology Advancement Project. As a possible follow-on to the eMMRTG effort, JPL is leading the development of an advanced thermoelectric converter based on the segmented skutterudite, $La_{3-x}Te_4$, and Zintl couple technology. A government-industry team is pursuing the modular ARTG (mod-ARTG) using segmented multi-couple modules in a two GPHS module assembly that produces about 43 W_e BOM. The design is scalable up to 18 GPHS modules, in increments of two, producing just under 500 W_e BOM. The Mod-ARTG is designed to operate in vacuum at a hot-shoe temperature of 1273K and a cold-shoe of 498K with an overall system efficiency of about 11%. The operating temperatures and system efficiency represent major improvements over the eMMRTG, which is projected to achieve about 8% system efficiency at 873K/473K. Some of the key component technologies needed to realize the Mod-ARTG concept include the

TE multi-couple module development, lightweight high-temperature MLI, compliant cold-shoe, aerogel encapsulation, sublimation control, and life verification.

GRC is leading the RPS Stirling technology development under TAP with an emphasis in three principal areas: hot-end components, cold-end components, and systems/testbeds. Under hot-end components, work has focused on improved thermal insulation materials, Stirling-specific MLI packaging, and heat source backup cooling using variable conductance heat pipes (VCHP). The cold-end components effort has developed advanced NdFeB magnets for higher temperature alternators, high temperature organic adhesives and wire insulation, and titanium-water heat pipes for heat rejection. The systems/testbeds task has demonstrated new fault-tolerant electrical controller architectures for both single- and dual-Stirling convertor systems and pursued mechanical balancers that permit single, unopposed convertors to operate with low vibration. In addition to the RPS-based Stirling technology development, STMD is developing a 12 kW_e-class Stirling power conversion unit (PCU) for future FPS that includes dual, opposed 6 kW_e engines that share a common expansion space and a pumped NaK hot-end heat exchanger.

3.4 | Design Reference Radioisotope Power Systems

The DRS that were selected by the Mission Study Team from the parametric option sets were further refined by the SST through two face-to-face team meetings and various follow-up studies. On July 9-10, 2014, the SST met at GRC to define system configurations, review integration options, identify technology challenges, and develop performance and mass estimates. On August 13-14, 2014, the SST met at DOE Y12 to define notional system development plans, review technology risks and opportunities, establish a cost estimation methodology, and generate Rough-Order-of-Magnitude (ROM) system cost estimates. The mission studies resulted in seven discrete DRSs: 9-GPHS ARTG, 16-GPHS ARTG, 4-GPHS SRG, 6-GPHS SRG, 1 kW_e TE FPS, 1 kW_e Stirling FPS, and 10 kW_e Stirling FPS. In order to simplify the process, and with consent from the Executive Council, the SST reduced the list to five DRSs excluding the 9-GPHS ARTG and 4-GPHS SRG given their similarity to the larger RPS counterparts. The five DRS are described in greater detail in the proceeding sections. System development plans and cost estimates were generated for each, and are presented in Chapter 5.

3.4.1 | Advanced Radioisotope Thermoelectric Generators

In early 2014, a system engineering study of conceptual ARTG designs was completed. The study was supported by NASA's RPS Program and conducted by AR and TESI [102]. The baseline thermoelectric materials and couple technology used in this study was the 15% efficient segmented thermoelectric couple demonstrated in 2011 under the TAP ATEC task led by JPL. The segmented-couple technology utilizes the following thermoelectric materials: n-type and p-type filled skutterudites for the lower temperature segments and n-type La_{3-x}Te₄ and p-type Yb₁₄MnSb₁₁ rare earth compounds for the higher temperature segments. The chemical and thermal stability of these materials is being established through extended performance testing of up to two years under nominal and accelerated operating conditions. The 15% conversion efficiency was achieved for hot and cold side junction temperatures of 1273 K and 473 K respectively, which is relevant to space RTG operation.

The system conceptual design studies were grounded in various degrees by data from heritage systems: GPHS-RTG, Modular Radioisotope Thermoelectric Generator (MOD-RTG) and MMRTG, and previous ARTG conceptual design development effort completed in 2006 in support of ATEC [103–105]. Key assumptions and requirements that were used in the 2014 study are summarized in Table 3-4. Design heritage from the GPHS-RTG includes the thermoelectric converter architecture with a large array of cantilevered couples bolted to the radiator, arrayed in a series-parallel electrical circuit, and radiatively coupled to the heat source. Additional heritage to the GPHS-RTG includes the use of multi-foil Insulation, the use of a mid-span support for designs with more than nine GPHS modules, and end-cap preloads for holding the GPHS module stack. The 2006 ARTG study work developed a modified cold end radiator attachment, and assumed the use

of opacified aerogel encapsulation of the segmented couples (from ATEC). In addition, the ARTG employed multi-foil insulation that replaced astroquartz separators (from GPHS-RTG) with zirconia particle spacers (from MOD-RTG). The GPHS modules used here are the “Step 2” modules, which are slightly larger and heavier than the “Step 0” or “Step 1” module designs used in the previous GPHS-RTGs.

TABLE 3-4 | KEY ASSUMPTIONS FOR NPAS ARTG CONCEPTUAL DESIGN STUDY

Category	Key Assumption or Requirement
Design	<ul style="list-style-type: none"> • Vacuum-only operation • Design life of at least 17 years; 3 years of storage, followed by 14 years after beginning of mission (BOM is defined as Launch) • Capable of withstanding EELV launch loads
Heat Sink Environment	<ul style="list-style-type: none"> • Worst design case: Venus Gravity Assist – 270 K heat sink • Best design case: deep space – 4 K heat sink
Operation	<ul style="list-style-type: none"> • Operating voltage range of 22-36 VDC, with a design load voltage equal to 32.8 VDC • Conductive heat flow from the ARTG to the ARTG-Spacecraft adaptor is less than 50 W_{th} • No vibrations or EMI
Heat Source	<ul style="list-style-type: none"> • Step-2 GPHS modules; stacks of 8, 12, 16 or 18 GPHS modules • DOE-recommended specification of 250 +/- 6 W_{th} per GPHS module • Maximum thermal load of 4,500 W_{th} (equivalent to 18 GPHS modules)

The updated 2014 ARTG conceptual design is shown in Figure 3-1 with its array of 415 discrete segmented couples. The couple design includes a heat collector, aerogel-encapsulated thermoelectric legs and a mechanically compliant, low thermal resistance cold shoe for bolting to the radiator. The design was constrained by the current method of transporting a RPS in the US with limits on both thermal loading (~4500 W_{th}) and physical length of the RPS, thus the 18 GPHS-RPS unit is bound by these restraints. Figure 3-2 summarizes analytical results from the 2014 ARTG study conducted by AR and TESI. The figure highlights the performance trade-off between power output and specific power that results from reducing the segmented couple cold junction temperature (while maintaining the hot junction temperature at 1273 K). The compromise adopted for the NPAS ARTG was to select a cold junction temperature of 498 K, which offers a high electrical power output at an operating point slightly below the maximum specific power condition (achieved at a temperature ~ 523 K). When comparing with the heritage GPHS-RTG, it can be seen that the largest 18-GPHS ARTG design is projected to achieve large gains in electrical power output (~515 W_e versus 285 W_e) and system specific power (~ 8.6 W_e/kg versus 5.1 W_e/kg). Scaling down from the 18-GPHS module configuration leads to slightly lower generator efficiencies and specific power due to the influence of the end cap on thermal losses and overall mass fraction. A parametric analysis based on the 8, 12, 16 and 18-GPHS module configurations was used to produce single point design ARTG characteristics between 8-GPHS module and 18-GPHS module systems in single GPHS module increments (see Table 3-1). The mid-span support is needed for any ARTG configuration with more than 9 GPHS modules. The Mission Study Team selected two specific configurations for its mission case analyses, a 9-GPHS ARTG and a 16-GPHS ARTG.

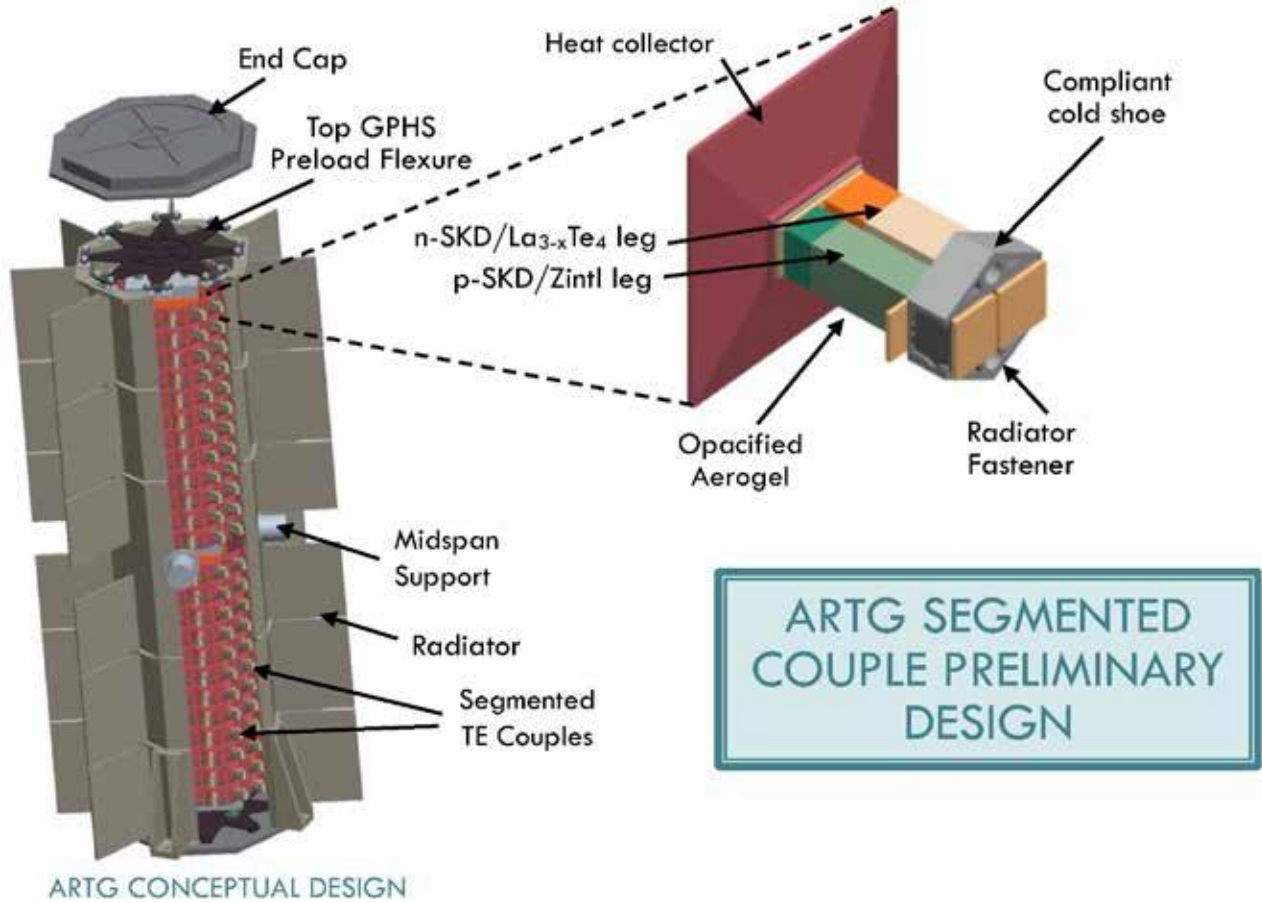

FIGURE 3-1 | ARTG 500 W_e-CLASS CONCEPT WITH SEGMENTED TE COUPLES

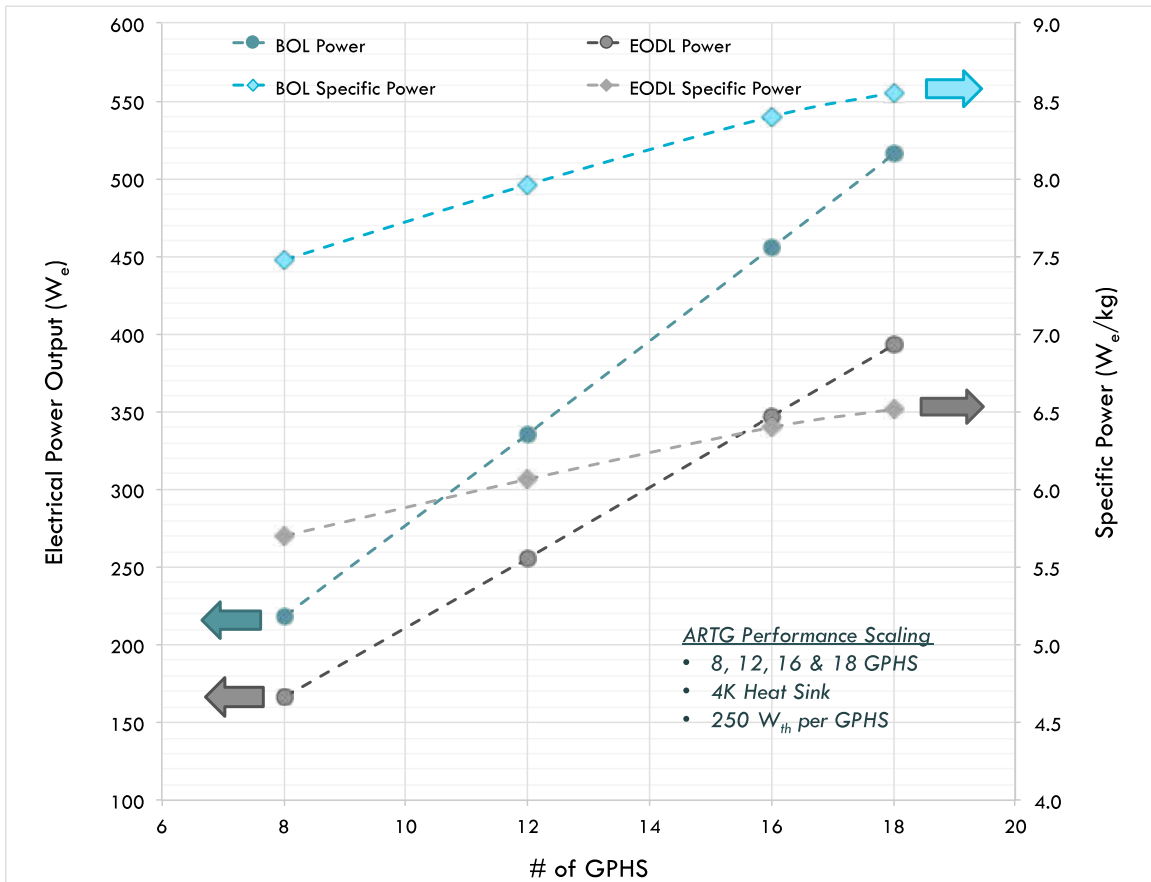
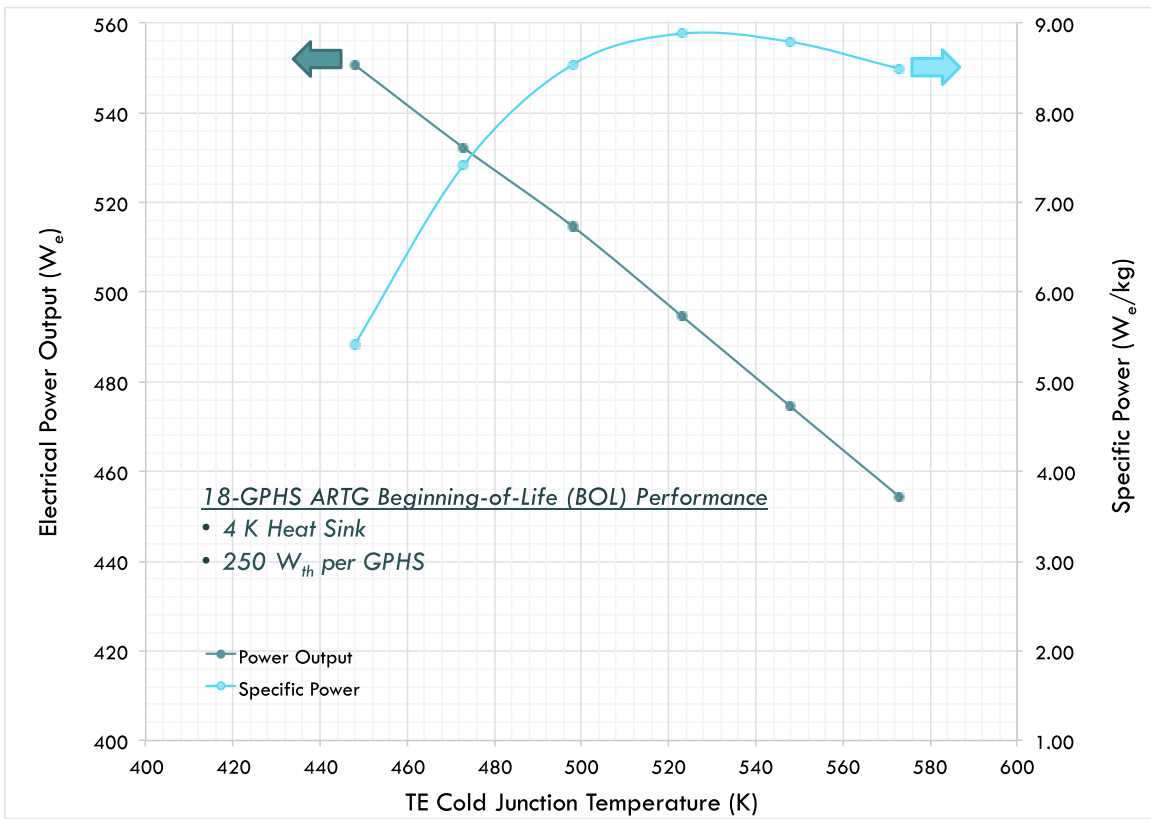

FIGURE 3-2 | ARTG ELECTRICAL POWER OUTPUT AND SPECIFIC POWER PERFORMANCE PREDICTIONS

3.4.1.1 | Modular ARTG concept

The Modular ARTG (Mod-ARTG) provides a promising solution for missions wishing to optimize the RTG unit size for end-of-mission power requirements while minimizing the impact on spacecraft accommodations and operations. The Mod-ARTG concept and evaluation benefited from the previous development in the mid 1980s of a MOD-RTG Ground Demonstration System based on Si-Ge thermoelectric couple/module technology and the GPHS-RTG heritage system. The 2014 AR/TESI ARTG conceptual system study considered 4-GPHS Mod-ARTG segments that could be stacked together up to the larger 16-GPHS ARTG selected for NPAS, as shown in Figure 3-3.

Similar configurations can be derived from 1-GPHS module or 2-GPHS module segments. However, a study should be conducted to determine an optimal segment size based on mission requirements and manufacturability. To maintain a generator output voltage of 32.8V across all possible configurations necessitates the use of segmented skutterudite/ $\text{La}_{3-x}\text{Te}_4/\text{Yb}_{14}\text{MnSb}_{11}$ TE multi-couple modules (as opposed to discrete couples). The Mod-ARTG would enable more flexibility for missions to customize their power system. At roughly $20 W_e$ for a 1-GPHS module segment, $43 W_e$ for a 2-GPHS module segment and $96 W_e$ for a 4-GPHS module segment, mission users could minimize the number of Mod-ARTG systems and potentially save fuel and RTG production costs. In similar fashion to the single point ARTG designs, Figure 3-4 shows that performance improves for larger Mod-ARTG sizes due to a reduction in the relative impact of end caps on thermal losses and system mass. The analysis is based on the 4-GPHS module stackable segment, but is representative of what would be expected for 1- or 2-GPHS module segments.

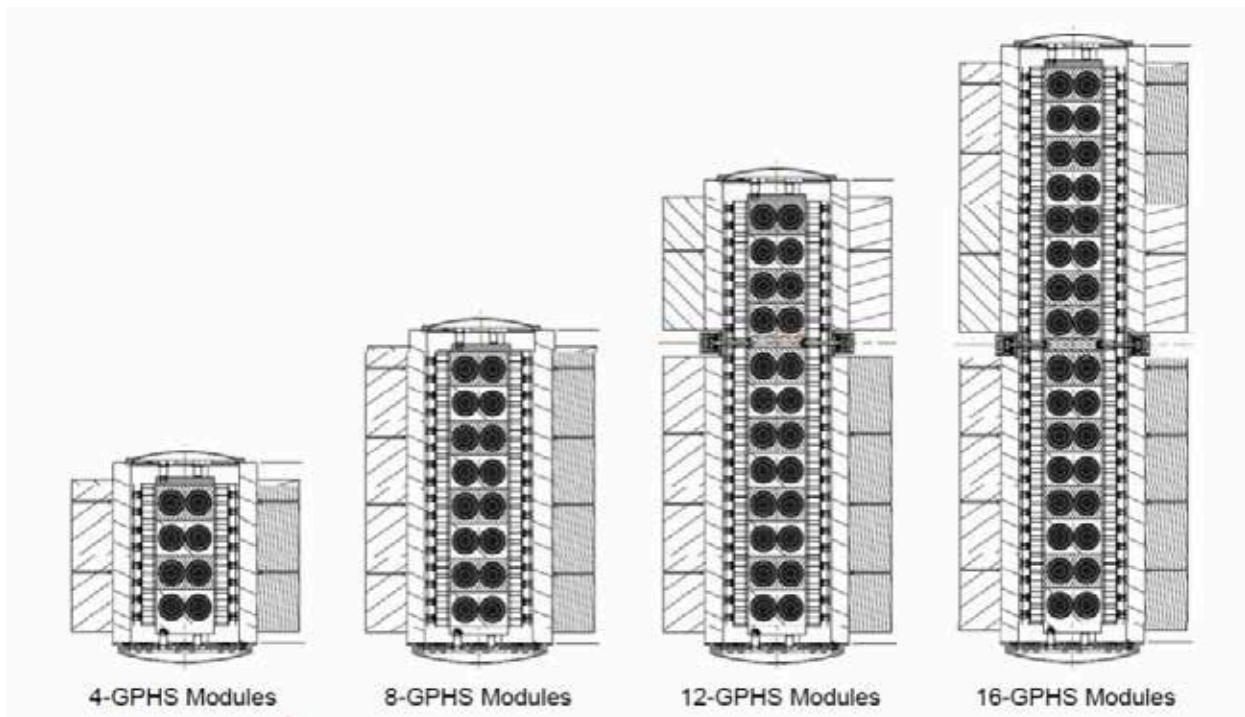

FIGURE 3-3 | MOD-ARTG CONFIGURATIONS BASED ON A 4-GPHS STACKABLE SEGMENT

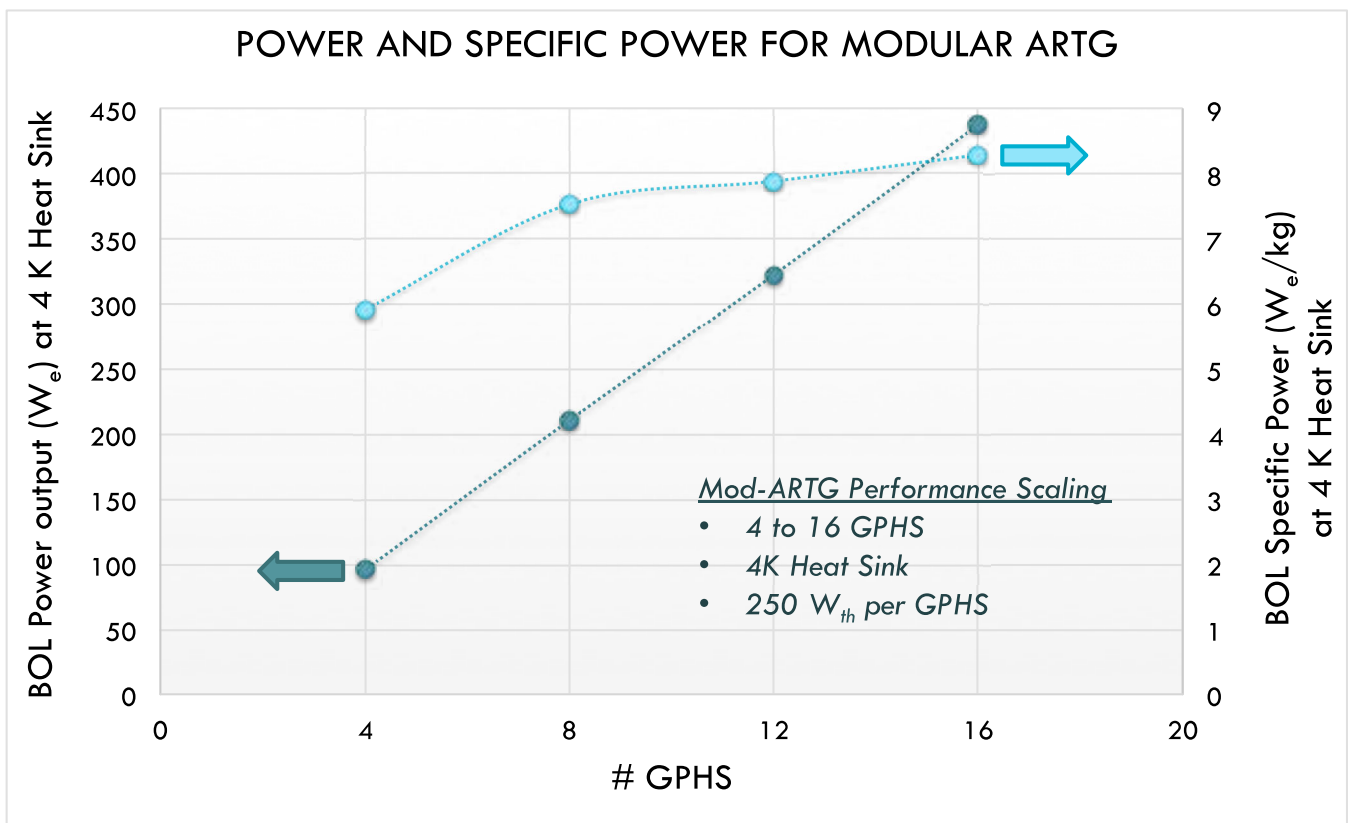

FIGURE 3-4 | ELECTRICAL POWER OUTPUT AND SPECIFIC POWER OF MOD-ARTG CONFIGURATIONS

3.4.1.2 | Thermoelectric Extensibility to FPS

Heritage RTG systems have mainly used a converter array configuration with hundreds of discrete TE couples interconnected on the cold side in a series-parallel “laddering” pattern to achieve high redundancy and eliminate single point failures. However, when scaling up to higher power levels, the use of discrete TE couples becomes less practical due to the large quantities and constraints imposed by system integration. Some such thermoelectric system applications have instead used arrays of multi-couple modules (referred to here simply as “TE modules”).

The use of TE modules is also required for “low power” system designs if requirements dictate a high TE module output voltage (e.g. 28V), which translates into a large number of couples with high aspect ratio. The best approach for practical and efficient thermal/mechanical integration with the heat source and heat rejection system components is to assemble these high aspect ratio couples into robust TE module structures. This approach was employed for the Mod-ARTG and the TE FPS concept configurations where the converter architecture and large number of couples dictated the use of TE modules. As an example, an 8-GPHS Mod-ARTG made of 2-GPHS module stackable segments requires that each segment maintain the same number of couples in its series-parallel configuration as found in a traditional full size ARTG (416 couples for a 16-GPHS module unit). The 8-stack Mod-ARTG would require 8x416, or 3328 segmented couples, with each couple having 8 times smaller cross-sectional area (no change in total footprint of the TE converter for preserving the same thermal resistance between heat source and radiator). This leads to replacing the segmented couples in the traditional RTG design with an 8-couple TE module in the stackable Mod-ARTG, and each 2-GPHS module segment having 52 TE modules. Similarly, the small FPS converter and radiator subsystem is composed of an array of 18 heat pipes, each heat pipe supporting 21 TE modules and their radiator fin, for a total of 3024 TE couples [106]. Table 3-5 summarizes the TE module characteristics for the Mod-ARTG and 1 kW_e TE FPS.

TABLE 3-5 | 8-COUPLE TE MODULE CHARACTERISTICS FOR THE MOD-ARTG AND 1 kW_e TE FPS CONCEPTS

Module Characteristics	Modular ARTG	1 kW _e TE FPS
Number of couples	8	
TE Materials	Skutterudites/La _{3-x} Te ₄ /Yb ₁₄ MnSb ₁₁	
Heat source coupling	Radiative with heat collector	Conductive, bare hot shoe
Heat sink coupling	Cantilevered, bolted to radiator	Spring-loaded module bar
Hot Junction temperature (K)	1,273	1,060
Cold Junction temperature (K)	498	505
Leg height (mm)	12.73	
p-leg cross-section (mm)	1.67 x 2.49	3.28 x 4.57
n-leg cross-section (mm)	1.67 x 1.67	3.28 x 3.28

The multi-couple segmented TE module is a potential common building block to various system applications, including the ARTG, Mod-ARTG, high-temperature MMRTG (HT-MMRTG),²³ and small TE-based FPS. Depending on the application and its configuration for coupling to the heat source (radiative or conductive) and heat sink, the basic segmented “skeleton structure” can be integrated into cantilevered or spring-loaded TE module configurations, as shown in Figure 3-5. The “skeleton structure” would consist of an array of eight segmented couples mechanically and thermally assembled into a single structure. The TE module would utilize a common hot shoe, having a compliant metal/ceramic header, and cold side interconnects. The couples are based on ATEC technology with skutterudites/La_{3-x}Te₄/Yb₁₄MnSb₁₁ materials capable of providing up to 15% device efficiency (for 1,273 K/473 K hot and cold junction temperatures). The eight-couple skeleton structure is already configured internally in a series-parallel laddering circuitry, so that the full converter simply consists of all of the modules connected electrically in series. Additional parallel circuits could be added for higher power systems. Four-couple and eight-couple segmented TE module prototypes have been developed for proof-of-concept converter demonstrations in solar-thermal (radiative heat source coupling) [107] and fossil fuel combustor (conductive heat source coupling) generator applications [108].

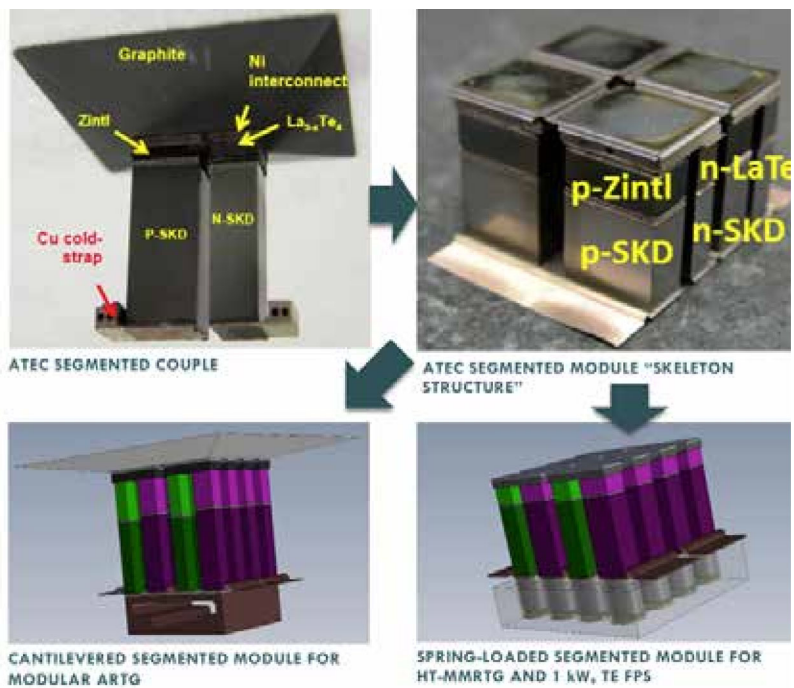

FIGURE 3-5 | COMMON BUILDING BLOCK SEGMENTED THERMOELECTRIC MODULE FOR ARTG AND 1 kW_e TE FPS

²³ The High Temperature Multi-Mission Radioisotope Thermoelectric Generator (HT-MMRTG) concept was developed in 2014 as part of the advanced RTG conceptual studies conducted by industry and funded by the RPS Program. The HT-MMRTG is based on the MMRTG system, but would enable segmented thermoelectric couples and modules to operate up to hot-junction temperatures of ~1125 K (instead of ~ 815 K in the MMRTG, and ~ 875 K in the eMMRTG) thanks to the use of higher temperature heat source support, a higher temperature-capable liner and improved thermal insulation. The HT-MMRTG concept has the potential to increase Beginning-Of-Life (BOL) power by an additional 60 to 70 W over the MMRTG, and 30 to 40 W over the eMMRTG.

3.4.1.3 | ARTG Observations

The ARTG and Mod-ARTG concepts are derived from the GPHS-RTG and the previous MOD-RTG Ground Demonstration System. The concepts were last updated by industry (AR/TESI) in early 2014 producing information on performance, physical characteristics, component and system mass, and sensitivity to various heat sink environments. The NPAS reference mission study results indicated that a higher power RPS unit ($\sim 300 W_e$ at EOM) might offer benefits to future missions. The Mod-ARTG approach allows mission planners maximum flexibility with power system sizing, minimizing the number of RPS units for any given mission, thus simplifying spacecraft accommodation, and potentially reducing Pu-238 fuel and RPS production costs.

Building on the inherent modularity and scalability of thermoelectric converters, a Mod-ARTG system would provide a unique capability to mission planners. In addition to providing significant performance gains over heritage RTGs, the Mod-ARTG allows for “custom sizing” of power systems in increments as small as $23 W_e$, with scaling up to a 500 W-class system. It would make use of ATEC segmented TE couple and module technologies, which have demonstrated a 15% device efficiency. The segmented TE module is the common building block for TE RPS and FPS applications owing to its ability to be easily configured for radiative or conductive coupling to heat sources and arrayed into converter slices for expansion to high power systems.

3.4.1.4 | Possible Near-term ARTG Forward Work

Recommendations for near term ARTG forward work include technology advancement and system engineering studies with reevaluation of mission needs and requirements at regular intervals. Technology advancement activities should focus on continuing ATEC technology development with the goal of transitioning to a “Technology Maturation” project that can address flight requirements. Figure 3-6 provides a preliminary timeline for ATEC technology advancement to an ARTG Technology Maturation start in FY2020 with a potential transition to a Mod-ARTG flight system development in FY2024. Based on prior RTG flight system development, the Mod-ARTG could become available to mission users in the early 2030s. ATEC device technology development activities should expand from single couples to multi-couple modules. A parallel task could focus on maturing advanced multi-foil insulation with zirconia spacers instead of astroquartz layers.

Industry, NASA, and DOE should conduct collaborative system studies to mature the Mod-ARTG concept with consideration for possible FPS applications. In particular, trade studies related to Mod-ARTG stackable segment size, TE module size, and detailed module configurations based on the common TE building block should be developed. In addition, risks related to other system component technologies (advanced thermal insulation, end caps, etc.) should be investigated prior to a potential transition to flight system development. Finally some assessment should be done to better understand qualification requirements for the Mod-ARTG and explore their applicability across the full range of system sizes. It is also important that the program periodically revisit performance projections, development risks, and relevance of proposed system concepts in light of the latest mission needs and requirements.

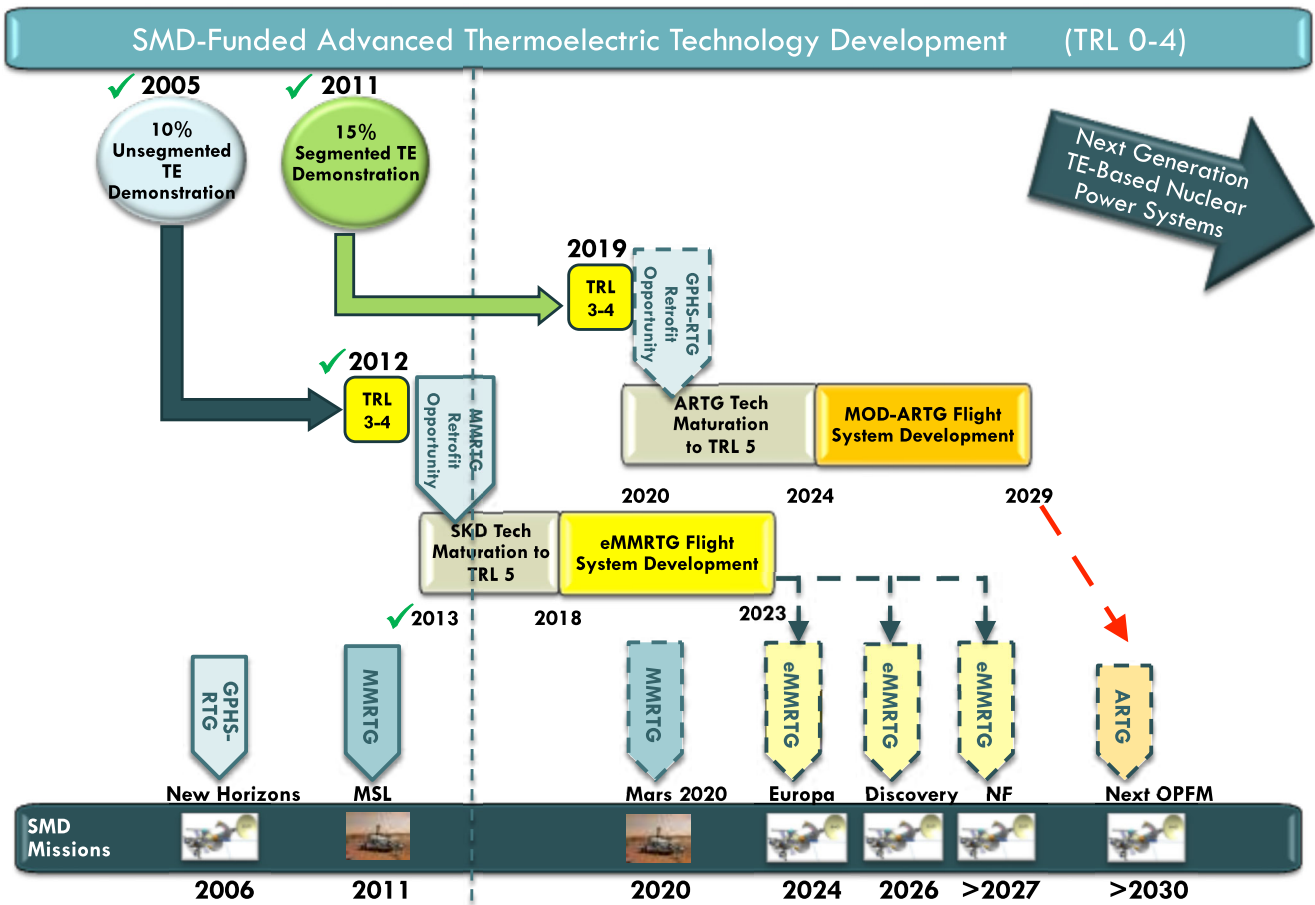

FIGURE 3-6 | THERMOELECTRIC TECHNOLOGY ROADMAP

3.4.2 | Stirling Radioisotope Generators

The development of any future SRG will most certainly be influenced by the experience gained during the SRG-110 and ASRG projects. The previous investments resulted in technology and engineering advancements that are relevant to future Stirling power systems. The SRG activity started with Small Business Innovation Research (SBIR) contracts placed by both DOE and NASA in the 1990s, progressed through a NASA Research Announcement (NRA) technology development, and led to the first engineering unit system [109], additional engineering model test articles, and flight hardware components built under the DOE flight project. Following the flight project cancellation, GRC initiated assembly of the second Engineering Unit (EU2) generator, shown in Figure 3-7, which uses two flight-like E3 model Advanced Stirling Convertors (ASC) and the version 4.0 Engineering Development Unit (EDU) ASC Controller Unit (ACU) [110]. While the design of a future Stirling generator may evolve from the EU2, much of the technology developed and much of the engineering practices are directly applicable.



FIGURE 3-7 | ASRG ENGINEERING UNIT 2

Following the ASRG flight project, many “lessons learned” were captured by DOE, NASA, and Lockheed Martin. One of the most overarching lessons concerns the trade in the Stirling convertor design between performance and robustness. The prior SRG-110 was based on the Technology Demonstration Convertor (TDC) that has been shown in the laboratory to be robust and reliable, with the longest operating convertors having more than 10 years of operations. The ASRG used the ASC that provides higher efficiency than the TDC, along with lower mass and reduced volume. The ASC originated from a technology advancement effort and then transitioned to the flight project [111]. One lesson learned is that the effort to transition the ASC from technology to flight development did not emphasize reliability and robustness sufficiently. Thus, reliability needs to receive greater attention in future Stirling convertor trades and hardware development.

Prior to the SRG-110 project, there were studies performed by NASA and DOE to evaluate various system configurations. The results from these studies were used to prepare system requirements to guide industry teams developing candidate conceptual designs. Three industry teams presented their conceptual designs to the Government, leading to the eventual selection of Lockheed Martin to develop the system. Based on fueling and launch safety considerations the final design coupled one GPHS module to one convertor, in a dual-opposed assembly, with no ability to share heat or maintain generator power output after a convertor fault. Among the options considered during the concept studies was the use of oversized convertors sharing a central heat source that could accommodate failures by operating with increased heat input and power output to maintain generator output. Based on the ASRG experience, it would be worthwhile to revisit these trades in determining the best power level for the next convertor and/or generator. However, these trades must consider the fueling and safety implications that might arise with an alternative configuration.

Table 3-6 presents a partial summary of free-piston Stirling convertors that could be considered for space use. The 55 W_e TDC, built by Infinia Corporation, uses flexure bearings instead of gas bearings. The TDC is slightly larger and less efficient than the ASC. The 1 kW_e P2A is a commercially produced unit used in terrestrial cogeneration applications, with technology licensed by Sunpower to Microgen Engine Corporation. The Power Conversion Unit (PCU) is a new Sunpower design, being developed by STMD under the Nuclear Systems Project that uses two 6 kW_e engines for NASA fission surface power applications [112].

TABLE 3-6 | AVAILABLE STIRLING CONVERTOR OPTIONS



	Infinitia TDC	Sunpower ASC	Sunpower P2A	Sunpower PCU
Nominal (W_e)	55	80	1,000	6,000
Range (W_e)	30-60	60-100	800-1,300	4,500-7,200
T_{hot} °C	650	760	550	575
T_{cold} °C	120	90	50	100
Frequency (hz)	80	100	50	60
Piston Amp. (mm)	5.6	4	10	16
Approximate Mass (kg)	4.5	2-3	35	100
Status	16 units, 4 on test at GRC	28 units, 14 on test at GRC, 1 in production at SP	>10,000 units built by Microgen (China)	2 prototypes built at SP for 12 kW _e assembly

3.4.2.1 | Common Convertor SRG Concept

Power requirements for upcoming planetary science missions vary over a relatively wide range. They can be as low as 110–200 W_e for a Discovery-class mission, to perhaps as high as 1000 W_e for a Flagship-class mission. New Frontiers missions fall somewhere between these two, requiring about 400 W_e of power. While high efficiency Stirling convertors can be designed over this power range, it may not be practical to develop a separate convertor for each mission class. One challenge was to determine if a single Stirling convertor unit could be developed and used in multiples to serve the entire range of power needs. Further, if a single convertor could be identified to meet science mission needs, an additional challenge would be to determine if this convertor could be extended further to meet the needs of HEOMD missions.

Stirling convertors have been shown to provide up to 40% efficiency at RPS representative operating temperatures, over the range of power levels of interest for NPAS and beyond. A new convertor design could sacrifice some of the high efficiency to obtain greater robustness and reliability. The new design could incorporate lessons learned from ASRG, while maintaining technical heritage with the ASC or TDC to leverage their extensive convertor testing history [113]. It may be desirable to incorporate features that extend the mission use (e.g. higher temperature alternators to accommodate Venus flybys) or to improve fault tolerance (e.g. mechanical balancers to allow continued low-vibration operation after a mating convertor stops). Ideally, the goal is to identify a single convertor that could be used in multiples across the entire RPS power range and also serve the FPS power class. As a minimum, it would be beneficial for RPS and FPS Stirling convertors to utilize common design elements such as alternator magnets, cold end heat pipes, and modular controllers. However, the process should avoid an outcome in which a common convertor design results in significant compromises across the different system applications.

A potential strategy was developed during the NPAS to implement a single 200 W_e ASC-H (H for high power) convertor in a myriad of configurations to meet the broad range of planetary science power requirements. The results are summarized in Figure 3-8. In the first column is a representation of the ASRG with its two 80 W_e ASCs, each coupled to a dedicated GPHS module. Note that the concept is shown without

the typical external housing that serves as the structure and heat rejection radiator, although that would be required for all of the options. The SRG-200 option is a candidate for Discovery class missions. In this configuration, two ASC-Hs share a common 3-GPHS module assembly, with provisions to allow a convertor failure and still produce full generator power. The New Frontiers-class SRG-400 could utilize the same two ASC-Hs with a shared heat source having 6 GPHS modules. In this configuration, the system could produce 50% power after a convertor loss by using heat pipes and mechanical balancers. A full range of GPHS module configurations are presented for the Flagship-class SRG-500. The four ASC-Hs could share a common 8 GPHS module assembly, similar to the SRG-200 and SRG-400 arrangement. Or, the SRG-500 could be configured with distributed heat sources, like the ASRG, with two independent assemblies of two convertors sharing four GPHS modules. A third option for the SRG-500 places all the GPHS modules in a stacked assembly that is partially separated from the ASC-H convertor bank, with heat pipes to transport the thermal energy from the GPHS modules. This approach is similar in concept to the 1 kW_e Stirling FPS (KP-1) configuration in which a 4.3 kW_{th} reactor delivers its heat to eight ASC-Hs via primary heat pipes. All of the configurations presented in Figure 3-8 utilize the common ASC-H Stirling building block, and any of the generator configurations are viable options for further study.

Several new features were considered in developing the candidate Stirling generator configurations. These features need to be studied in more detail to fully understand the impact on generator performance, integration complexity, safety, and reliability. One possible feature is a dynamic balancer that could be used to maintain dynamic balance in the event of a Stirling convertor stoppage. Balancers of this type have been used on Stirling coolers and can be either passive (no power input) or active (a small amount of driving power). The SRG application could use an active balancer, so the impact of the mass, additional parts, and controller complexity needs to be considered relative to the merit of the healthy Stirling convertor continuing to operate after its opposing mate has stopped. Another feature that should be revisited in sizing the next Stirling convertor and generator is the concept of a shared heat source among several convertors, with the convertors operating at de-rated power during nominal conditions. In the event of a Stirling failure, the remaining healthy Stirling convertors would then increase their power output, by absorbing the heat that is not being consumed by the failed convertor. The shared heat source approach could also require a balancer to maintain low vibrations in the event of a convertor failure.

Some system configuration options may be enabled with the use of heat pipes. Heat pipes at either the hot-end or the cold-end of the Stirling convertor may enable system configurations that otherwise would not be possible. At the hot-end, the ability to take heat to a convertor from a remote heat source, or any number of heat sources, without the need for them to be directly coupled may be beneficial. Hot-end heat pipes could also be used to divert GPHS module heat away from the convertor should there be a desire to stop the convertor during certain mission phases [114]. At the cold-end, a heat pipe eliminates the requirement for the Stirling rejecter to be conductively coupled with the heat rejection radiator. Cold-end heat pipes could also increase the allowable heat flux to accommodate larger Stirling convertors with greater heat rejection loads.

	ASRG	SRG-200	SRG-400	SRG-500		KP-1
BOM Power	140 W _e	193 W _e	370 W _e	495 W _e		1,097 W _e
Number of GPHS	2	3	6	8		Fission
Heat Source Configuration	Distributed & dedicated	Centralized & shared using heat pipes		Distributed & dedicated	Distributed & shared using heat pipes	
Stirling Configuration	2X 80W ASC	2X 200W ASC-H		4X 200W ASC-H		8X 200W ASC-H
						

FIGURE 3-8 | POTENTIAL GENERATOR CONFIGURATIONS USING A COMMON STIRLING CONVERTOR

3.4.2.2 | Proposed Design Improvements in the next SRG

Based on the engineering experience that was gained during the SRG-110 and ASRG projects, there are many areas for improvement that can be applied to future Stirling convertors and generators. Improvements in the convertor can generally be classified as those for reliability and robustness, and those that allow greater operational performance. The ASC has shown to have low mass and provide high efficiency compared to alternatives, however obtaining adequate robustness and reliability characteristics has proven to be difficult.

If a direct derivative of the ASC is pursued, areas that could be addressed include fasteners, gas bearings, running clearances, and internal debris sources. The fasteners used in the ASC tended to be very small and custom made. Potential design changes could eliminate some fasteners or result in the use of a more standard size fastener in order to reduce cost, time, and risk. The gas bearing system has been proven to be highly successful in production cryocoolers, but was difficult to implement in the ASC with consistent performance and margin that could be verified. The ASC’s high conversion efficiency depends on very small piston-cylinder running clearances. The clearances and the gas bearing feed system can be sensitive to debris, and the random fiber regenerator was a potential source of debris that was shown to effect convertor performance. If greater deviation from the ASC design is considered, potential options to improve reliability include flexure-based bearings, self-balanced convertors with dual pistons, increased internal clearances, and thermoacoustic Stirling configurations that eliminate the displacer.

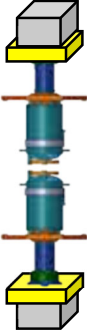
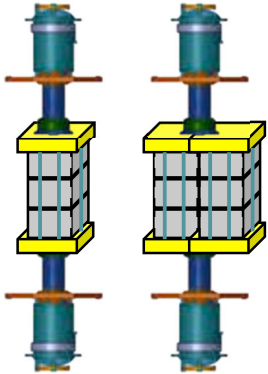
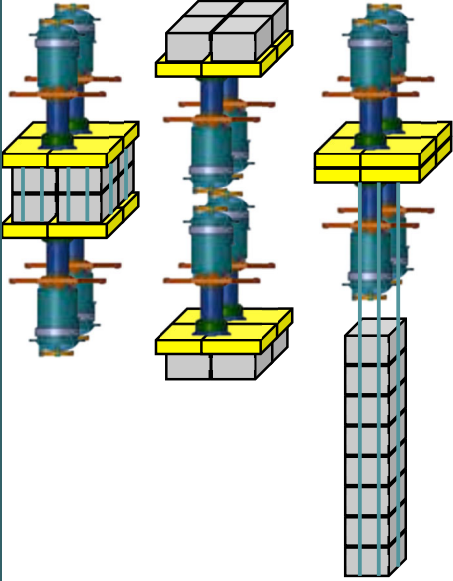
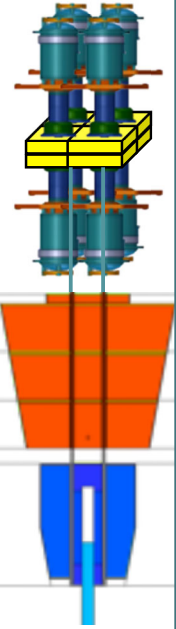
A future SRG could realize significant mass improvements by using MLI as the hot-end thermal insulation method [115]. The ASRG utilized solid bulk insulation, known as Microtherm HT, which permitted the multi-mission use of the generator in either space vacuum or in planetary atmospheres. The thickness of the Microtherm HT had a major influence on the size of the housing, which could otherwise be smaller if it were based strictly on radiator area. Technology development has been pursued at GRC to identify metallic foils and thermal insulating spacers that can operate at temperatures up to 850 °C and be packaged to provide a high efficiency MLI blanket surrounding the GPHS modules and Stirling heater head assembly. Analysis indicates a potential 20% system mass advantage with MLI as compared to bulk insulation. A portion of the savings comes from the ability to downsize the housing in accordance with the more compact MLI packaging. The key drawback is the restricted use of the generator to space vacuum environments. An MLI-based design would also require additional studies to evaluate fuel safety and impact protection.

It may be desirable to operate future SRG or small FPS with a higher Stirling cold-end temperature than the ASRG, to minimize radiator area and system mass. Some of the critical technology development needed to allow higher cold-end temperatures has already been completed. The ASC alternator was limited to approximately 130°C, primarily due to the permanent magnets. Higher temperature NdFeB magnets have undergone extended aging tests at GRC and have been integrated and demonstrated in a high temperature alternator. This magnet allows the alternator to operate up to about 200°C. In addition to the permanent magnets, there are organics used in the convertor that must be able to withstand the elevated cold end temperature. These include the liquid thread locker used on fasteners, adhesive used for attaching the magnets to the alternator can, epoxy used in potting the alternator coil, insulation on the alternator wire, and the low friction coating used on the close clearance moving parts of the convertor. Many of these organic materials have been evaluated to characterize performance and life.

Lockheed Martin delivered the EDU 4.0 ACU to GRC for use on the EU2 generator, and is planning to deliver EDU 4.1 to allow dual controller testing in the RPS System Integration Lab (RSIL). These controllers are representative of the flight controller that was planned for the ASRG flight system. As part of that same effort, Lockheed also authored a post-ASRG project technical paper that provides lessons learned from the ASRG controller development effort and options for improved controllers in the future [116]. These papers address SRG control over the power range from 80 W_e to several kilowatts. The most significant improvement came from a proposed change in overall controller architecture. Reliability of the ACU was based on an N+1 approach in which two controller cards control and synchronize the two convertors in a generator. If one of the two controller cards would fail, a third (spare) card would take over to maintain control and synchronization. As a result of their study, Lockheed concluded that an approach using “A-side, B-side”, as shown in Figure 3-9, could be simpler and more reliable. This configuration can be visualized as two controllers, with each controller having two control cards. Within each controller, much of the hardware and circuitry resides on a board that is used by both control cards. In this architecture, if one controller fails, the redundant controller takes over operation.

As a part of their study, Lockheed looked into the impact of controlling higher power levels [116,117]. It was found that the existing controller design could potentially be used with convertors as high as 170 W_e each. Further, improved cooling of the power electronics would allow power levels up to 250 to 350 W_e per convertor. Higher power levels could be accommodated with minor upgrades to the power electronics and circuitry that process the power flow. All power supplies and control logic elements could remain essentially unchanged.

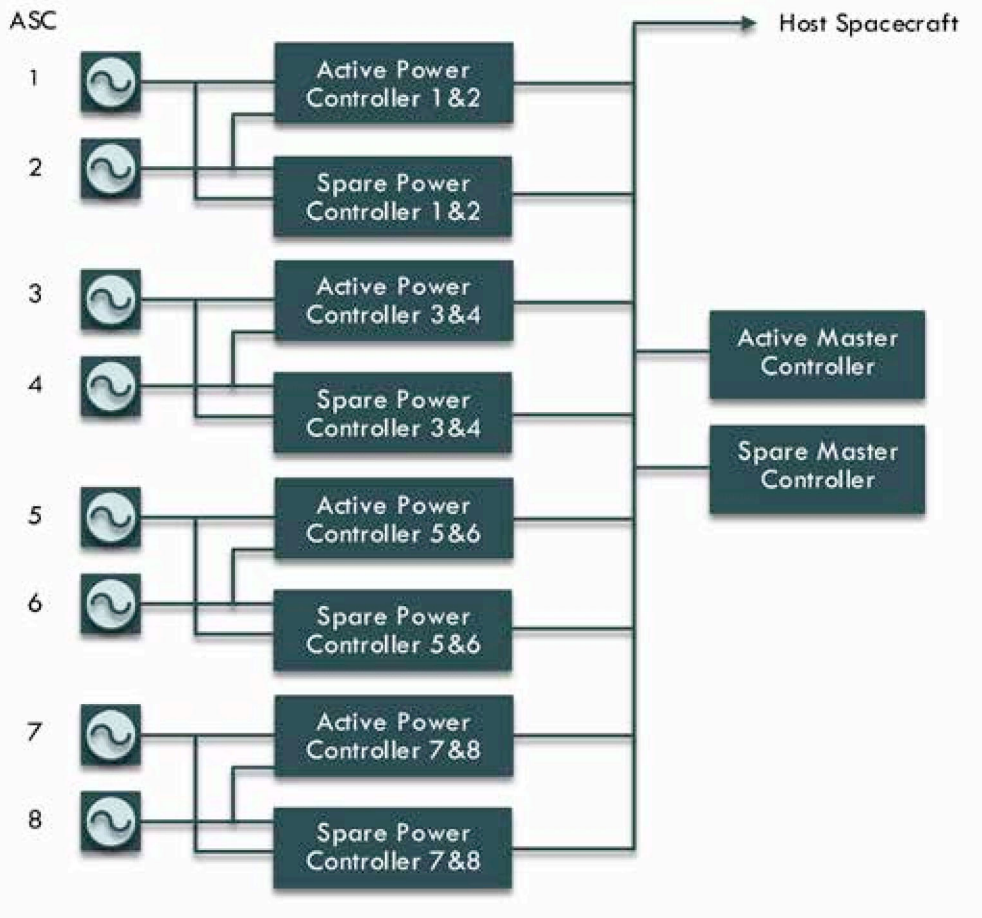

FIGURE 3-9 | ALTERNATIVE STIRLING CONTROL ARCHITECTURE

3.4.2.3 | Stirling Extensibility to FPS

In considering future Stirling convertors, heritage to previous convertors can be based on three different categories: technology, engineering, and/or design. Technology heritage represents the knowledge, information, and data that have been gathered across all prior developments. Engineering heritage refers to the design, analysis, and manufacturing methods that have been developed, refined, and validated. Design heritage relates to a specific configuration, component, or part that has been used previously and can be used in other applications with little or no modifications.

One of the benefits of the 200 W_e ASC-H concept that resulted from the sizing study is that it could share many common features with the ASC, leveraging the ASC's "technology" and "engineering" heritage. It can be also used over a wide range of power needs. The ASC-H can be used in SRGs from 200 W_e to 500 W_e , and it can also be used in the 1 kW_e Stirling FPS. It offers a direct link between RPS and FPS, with "design" heritage across multiple systems.

The eight ASC-H convertors in the 1 kW_e Stirling FPS (KP-1) may represent an upper limit for the number of convertors in a system, based on the concepts explored during the NPAS. Beyond eight convertors, the integration of the hot- and cold-end thermal transport as well as the electrical control becomes somewhat complicated. In order to scale upwards to a 10 kW_e -class FPS, it would prove extremely difficult to integrate fifty 200 W_e ASC-H units. Alternatively, the larger FPS could utilize a scaled convertor with lineage to the ASC but based more specifically on the 1 kW_e P2A (shown previously in Table 3-7). A 1.5 or 2 kW_e version of the P2A would provide a potential building block for an eight-convertor assembly in the 10 kW_e Stirling FPS. The commercial P2A would require technology maturation to address the requirements of space flight

(e.g. low mass, long life without maintenance). The P2A derivative (P2A-D) convertor would share “technology” and “engineering” heritage with the ASC, and at least some “design” heritage with the commercial P2A unit. While the production version of the P2A is manufactured by Microgen in China, the P2A-D could be designed, built, and tested with domestic vendors.

There are many internal Stirling component technologies that are common among ASC, ASC-H, and P2A-D. All convertor hot-end assemblies can use the same nickel-based superalloy heater head material and leverage successful non-destructive inspection methods established for the ASC. The regenerators could also employ the same material and random fiber geometry from ASC, if the debris issue can be resolved. The new designs could utilize a higher capacity version of the ASC hydrostatic gas bearing system, or a derivative of the TDC flexure bearings. The cold-end mechanical components could be similar, using scaled versions of the ASC’s piston, displacer flex rod, and planar spring. All convertors could use the same ASC-demonstrated xylan coating on the running surfaces, and a myriad of ASC organic compounds used for internal adhesives, o-rings, thread locking, and wire insulation. The alternators could share the same magnet can configuration, with a possible upgrade to the higher temperature NdFeB magnets that have been tested to 200 °C. In fact, many of the design strategies discussed above have been implemented in the 6 kW_e engines being developed by STMD for fission surface power.

Figure 3-10 provides a graphical summary of the potential Stirling extensibility between RPS and FPS. The ASC provides a critical technical foundation with heritage to the ASC-H and the P2A. The same ASC-H unit can be used in a two-convertor arrangement for the 6-GPHS SRG, representing a multitude of SRG options, and as an eight-convertor assembly for the 1 kW_e Stirling FPS. A notable difference between FPS and typical RPS is that the convertors in the FPS are separated from the heat source. However, it was conceptualized that one of the SRG-500 variants from Figure 3-8 that an SRG could be configured with a stacked assembly of GPHS modules and remotely heated convertors using primary heat pipes. This configuration has many similarities with the FPS approach.

The 10 kW_e Stirling FPS in Figure 3-10 represents a potential HEOMD Mars surface configuration with a deployable radiator. It could use the P2A-D convertor, with modest changes to power level, mass, and design life from the commercial version. The 1 kW_e and 10 kW_e Stirling FPS share the same convertor configuration with four pairs of dual-opposed convertors arranged with co-located hot ends to simplify heat transfer from the reactor. In the same way that the ASC-H can be used in multiples to meet a range of power requirements from 200 W_e (SRG-200) to 1000 W_e (KP-1), the P2A-D could serve FPS options from 3 to 10 kW_e. A 3 kW_e FPS (KP-3) could use two P2A-D units, while a 5 kW_e FPS (KP-5) could use four units, and a 10 kW_e FPS (KP-10) could use eight units.

The SRG and Stirling FPS options share other design elements beyond the Stirling convertors and internal Stirling component technologies. The systems could share similar thermal insulation materials (e.g. MLI or Microtherm HT), hot-end heat pipes, convertor integration structure, mechanical balancers, cold-end heat pipes, and radiator structure. Furthermore, a post-ASRG ACU analysis [116,117] indicated that the ASRG controller technology is scalable up to several kW_e with a relatively minor thermal management redesign. The 10 kW_e Stirling FPS could use an evolved, transformer-based version of the ASRG controller. The higher-power concept could employ input transformers to optimize the controller voltage and multiple SRG controller cards to share the power coming from a larger P2A-D convertor. While the evolved controller may result in modest mass increases and efficiency decreases relative to the ASRG controller, it offers scalability across all power levels of interest in this study.

3.4.2.4 | SRG Observations

The Stirling DRS that were studied for NPAS indicated that Stirling offers the highest efficiency option for RPS. Existing laboratory convertors have demonstrated conversion efficiency of almost 40% at RPS-relevant operating temperatures. The high efficiency allows system designers the ability to minimize the Pu-238 fuel

inventory with margin to trade efficiency for reliability or robustness. Stirling is also the only practical solution among the power conversion technologies considered by the SST that could achieve a 10 kW_e capability with the FPS heat pipe reactor. While this power level may be a stretch for most planetary science missions, with the possible exception of those that use electric propulsion, high power ($\sim >10\text{ kW}_e$) and robust high efficiency energy conversion technology (e.g., advanced Stirling convertors) are crucial to enabling future HEOMD crewed Mars surface missions once those requirements are defined and the KiloPower concept is found to be suitable.

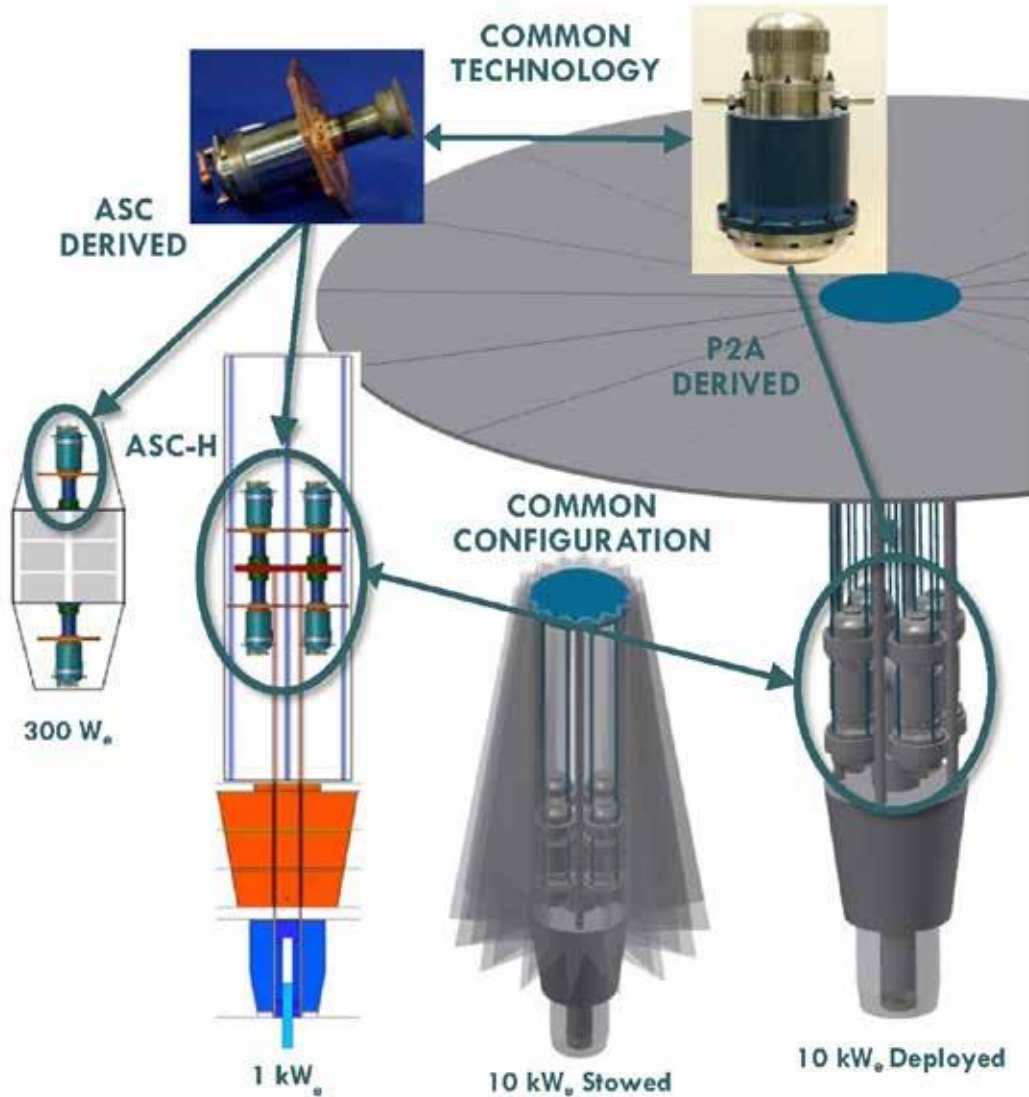

FIGURE 3-10 | STIRLING EXTENSIBILITY TO FPS

The availability of ASRG hardware assets presents several promising options for advancing the technology readiness of Stirling. The current EU2 generator can be used in ground tests to verify the system performance envelope and evaluate off-nominal operating characteristics. The six additional flight-like ASC-E3 units can be placed on extended operation testing and continue to contribute to that convertor reliability database. The two EDU controllers are available to perform integrated spacecraft bus testing to verify multi-generator electrical performance and demonstrate fault tolerance. Also, sufficient engineering model hardware may exist to consider a Stirling technology demonstration flight. A proto-flight approach could be used with available hardware assets to field an electrically heated ASRG on the ISS or as a hosted payload on an earth orbiting satellite.

A Stirling Technology Development Project could develop a higher power capability that incorporates lessons learned from ASRG. The technology maturation could focus on design improvements and new fault tolerance features that could extend the mission use for SRGs. The 6-GPHS SRG, capable of delivering 300 W_e at EOM, is a viable option for future Discovery and New Frontiers missions. The EOM power output fills a desired capability for planetary science and represents a single generator capability that clearly distinguishes Stirling from current MMRTGs. The generator could utilize a scaled and modified version of the ASC, designated ASC-H, which produces 200 W_e and could be used in both SRGs and small FPS up to about 1 kW_e . The ASC-H development paves the way for a larger, P2A derivative convertor that could be used in FPS up to 10 kW_e .

3.4.2.5 | Possible Near-term SRG Forward Work

The next steps in developing a new Stirling capability for SMD includes requirements definition and trades studies by the NASA-DOE team to formulate the convertor and generator design strategies. Relative to the convertor, near term studies could be conducted to select the preferred bearing approach, determine the appropriate running clearances, identify suitable materials to increase the convertor cold-end temperature, and resolve the regenerator debris issue. An emphasis should be placed on the manufacturability of repeatable, flight-quality convertors. As far as the generator is concerned, items that could be studied include the use of MLI, shared heat sources, spare convertors, mechanical balancers, hot- and cold-end heat pipes, and modular controllers. The new development should focus on retaining Stirling's high efficiency while introducing new features that improve robustness and reliability. This near term effort should include input from science mission users to make sure that their needs and concerns are addressed.

Prior to embarking on a Technology Development Project, a non-advocate review should be commissioned to assess the Stirling Technology Readiness Level based on the progress made under the ASRG and ASC development projects. This assessment should include an evaluation of all relevant Stirling technologies and design options that may be used in a future flight development. It should also include an assessment of the Stirling industry base as a means to identify all potential vendors.

3.5 | Design Reference Fission Power Systems

The FPS concept used for the NPAS started with the 2010 NASA/DOE Small Fission Feasibility Study performed for the National Research Council (NRC) Planetary Science Decadal Survey [2]. The basic requirements that guided that study included 1 kW_e system power output, 15-year full power design life, and 28 Vdc bus. Trade studies in 2010 reviewed many different reactor and power conversion combinations before settling on a baseline. The reactor design approach, shown in Figure 3-11, included a uranium-molybdenum (UMo) core with 10% Mo mass fraction and 93% highly enriched uranium (HEU) using a stack of solid, cast fuel plates. The fast-spectrum reactor concept utilized a beryllium oxide (BeO) neutron reflector and a single, centered boron carbide (B4C) startup rod. A B4C safety collar between the core and radial reflector was used to assure subcriticality under certain postulated launch vehicle accidents and was ejected after reaching orbit. The reactor was cooled by a series of eighteen potassium (K) heat pipes operating at a condenser temperature of 1100 K. The heat pipes extend through a conical shadow shield and deliver thermal power to the power conversion devices. A layered lithium hydride (LiH) and tungsten (W) shadow shield was sized to attenuate reactor radiation to less than 1×10^{11} n/cm² and 25 krad at a 10-m separation distance within a 4.5-m payload diameter.

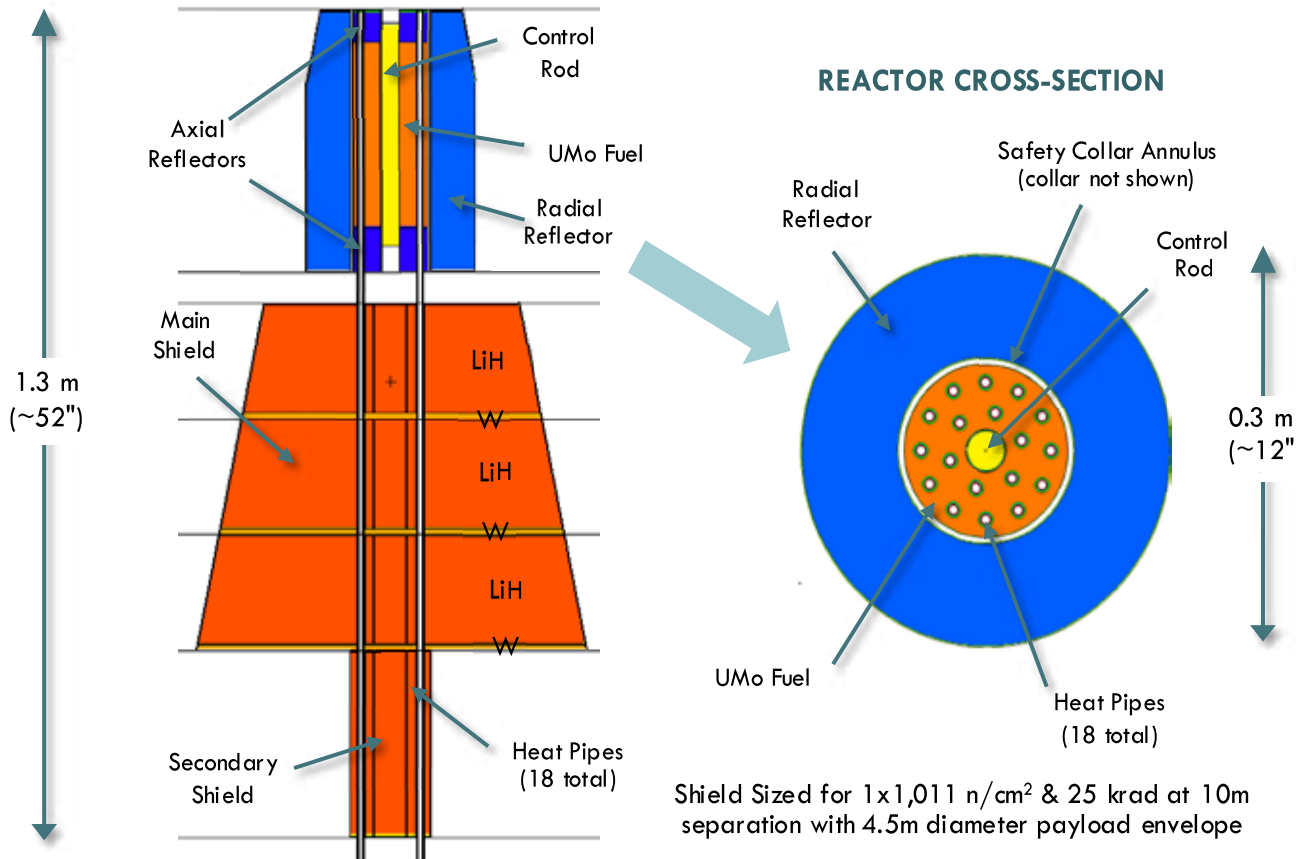

FIGURE 3-11 | REACTOR DESIGN FROM THE DECADAL NASA/DOE STUDY

The $13 \text{ kW}_{\text{th}}$ reactor could be combined with advanced thermoelectric (TE) conversion to produce 1 kW_{e} , as shown in Figure 3-12 or with Stirling convertors to produce 3 kW_{e} , as shown in Figure 3-13. The TE FPS used segmented skutterudite, $\text{La}_{3-x}\text{Te}_4$, and Zintl TE multi-couple modules distributed along the length of the heat pipe condenser sections that were directly bonded to aluminum radiator fins. The Stirling FPS used eight ASRG-derived Stirling convertors, which are coupled to the primary heat pipes via two copper heat collector blocks and cooled by secondary water heat pipes [118]. The estimated system mass was about 600 kg for the TE option and 750 kg for the Stirling option. The NRC team prepared a 10-year flight system development plan for the 2010 concept that was used at that time in generating a ROM system cost of \$690 million.

The 2010 FPS concept has evolved and undergone refinement through studies performed by GRC, Los Alamos National Lab (LANL), and the Y12 National Security Complex [119]. The present KiloPower concept serves as a reference design for a STMD Technology Demonstration Project that includes a nuclear-heated reactor demonstration test at the Device Assembly Facility (DAF) in 2017. The KiloPower technology effort was influenced by the 2012 Demonstration Using Flattop Fissions (DUFF) experiment at DAF that coupled an existing, spherical U-235 reactor core with a pair of Stirling convertors to produce 24 watts of electric power [120]. A lower development cost is projected for the KiloPower concept based on use of a UMo fuel form casting capability that is currently used at Y12, available ASRG-based Stirling convertors, and existing nuclear test facilities at the Nevada National Security Site (NNSS).

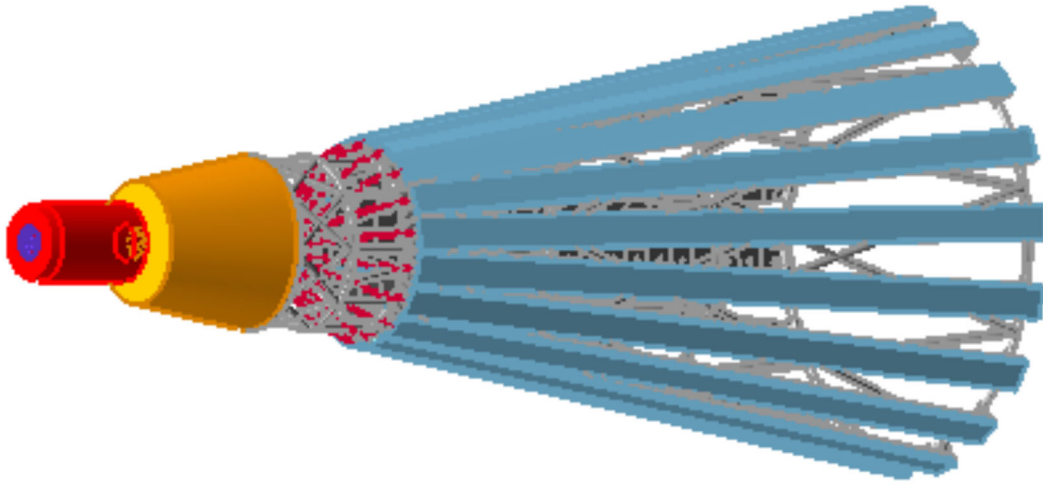

FIGURE 3-12 | 1-kW_e TE FPS FROM THE DECADAL NASA/DOE STUDY

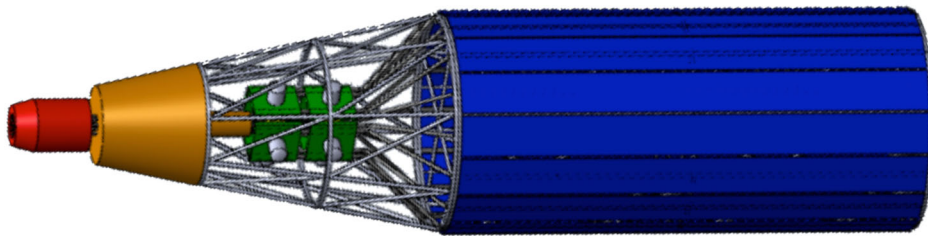

FIGURE 3-13 | 3-kW_e STIRLING FPS FROM THE DECADAL NASA/DOE STUDY

The 1 kW_e Stirling FPS concept produces about 1 kW_e using a 4.3 kW_{th} reactor core and eight modified ASRG Stirling converters, as shown in Figure 3-14. The smaller reactor core uses highly enriched UMo with 7-8% Mo mass fraction. Other changes relative to the 2010 design concept include fewer heat pipes (8), different heat pipe fluid (Na), different heat pipe envelope material (Haynes 230), ex-core clamped heat pipe thermal-mechanical integration, lower heat pipe temperature (1050 K), depleted uranium (DU) gamma shield rather than tungsten, and no B₄C safety collar. The estimated system mass for the 1 kW_e Stirling FPS concept is about 400 kg. The 4.3-kW_{th} core is small enough that it can be tested on the existing Comet criticality test stand at DAF in a system demonstration that includes Stirling converters.

A key feature of this reactor is the simple and predictable negative temperature reactivity feedback mechanism that allows the reactor to respond automatically to temperature, and thus, thermal load demand. Fast-spectrum reactors in this power range can be controlled by thermal expansion and negative reactivity feedback. Negative reactivity feedback causes the reactor power to decrease if less heat is extracted by the power conversion system. Because of this feature the reactor is self-regulating, with no requirement for active reactor control. The central B₄C rod in the FPS concept is only used for starting and stopping the reactor and to assure subcriticality in the event of a launch accident. A more complex control strategy may be considered and could be added to meet future mission or ground testing requirements, if necessary.

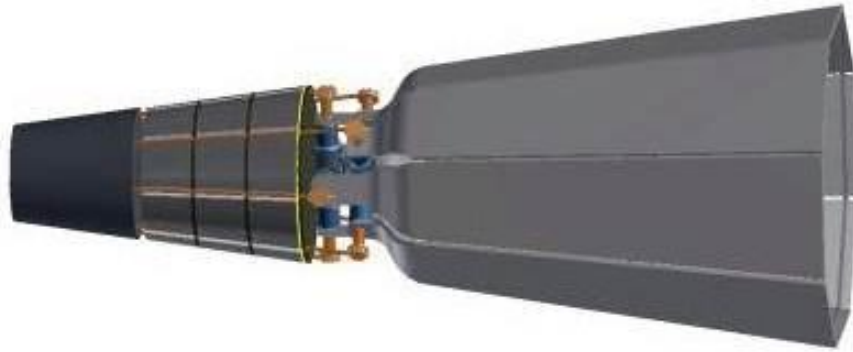

FIGURE 3-14 | 1-kW_e STIRLING FPS CONCEPT

3.5.1 | Fuel Assessment

The baseline FPS fuel form is a Uranium alloy with 7-8% Molybdenum operating at approximately 1100 K (825 °C) peak fuel temperature [121]. The fuel is projected to have a very low burn-up and very low fission product release given the low thermal power of the reactor. The burn-up would vary from approximately 0.08 atom percent to 0.5 atom percent over a 15-year operating life, in scaling the reactor from 4.3 kW_{th} to 43 kW_{th}. The fission density would be approximately 7×10^{10} fissions/cm³-s, a rate that is about 3 orders of magnitude lower than conventional reactor fuel. An important goal of an NPAS fuel assessment is to understand the prior UMo research and relevant data related to high temperature, low fission rate, and low burn-up fuel. This must include understanding the issues with the U-Mo alloy phase diagram, thermal cycling, heat treatment during casting, diffusion at high temperature, and fuel swelling over time.

A preliminary fuel assessment concluded that the UMo alloy should be operated in the “gamma” phase, which should minimize the fuel swelling at the specified conditions. In addition, particular attention should be paid to thermal cycling (reactor turning on or off) and diffusion of the UMo alloy to the heat pipe envelope. Early non-nuclear material coupon testing should be conducted to ascertain strength, creep, and diffusion characteristics. Additional testing including fuel sample irradiation trials and post irradiation examination (PIE) should follow. A potential approach to quantify fuel behavior uncertainty is the Phenomenology Identification and Ranking Table (PIRT) used by the Nuclear Regulatory Commission. While a great deal of information exists on metallic UMo fuel from the 1950s and 1960s for its application in sodium-cooled, fast breeder reactors, the higher operating temperatures which are key to the FPS concept here are quite different from those previously-investigated regimes. Ultimately, the fuel and fuel form will require additional testing to ensure stability at the operating temperature for the intended operating life.

3.5.2 | Reactor Description

The baseline 4.3 kW_{th} reactor is presented in Figure 3-15. The reactor core is a cast UMo alloy, with a diameter of 11 cm, length of 24 cm, and approximate mass of 28 kg. The peak fuel temperature is 1100 K. There is a 4 cm diameter B4C startup rod that inserts axially into an annulus along the core centerline. Eight heat pipes are positioned on the outer fuel boundary and attached using mechanical clamps or fasteners. The heat pipes transport the reactor thermal power to the power conversion system at an average condenser temperature of 1050 K, a value which led to the selection of Na as the working fluid with Haynes 230 as the wick and envelope. Each heat pipe is 1.27 cm in diameter and approximately 3 meters long. The heat pipe design includes a factor of two margin in power throughput, with each heat pipe capable of carrying about 1 kW_{th}. The neutron reflector material is BeO, which is used in a 20-cm thick radial reflector, a 9-cm thick upper axial reflector, and a 7-cm thick lower axial reflector. The total reactor mass including core, heat pipes, reflector, and startup rod is about 134 kg.

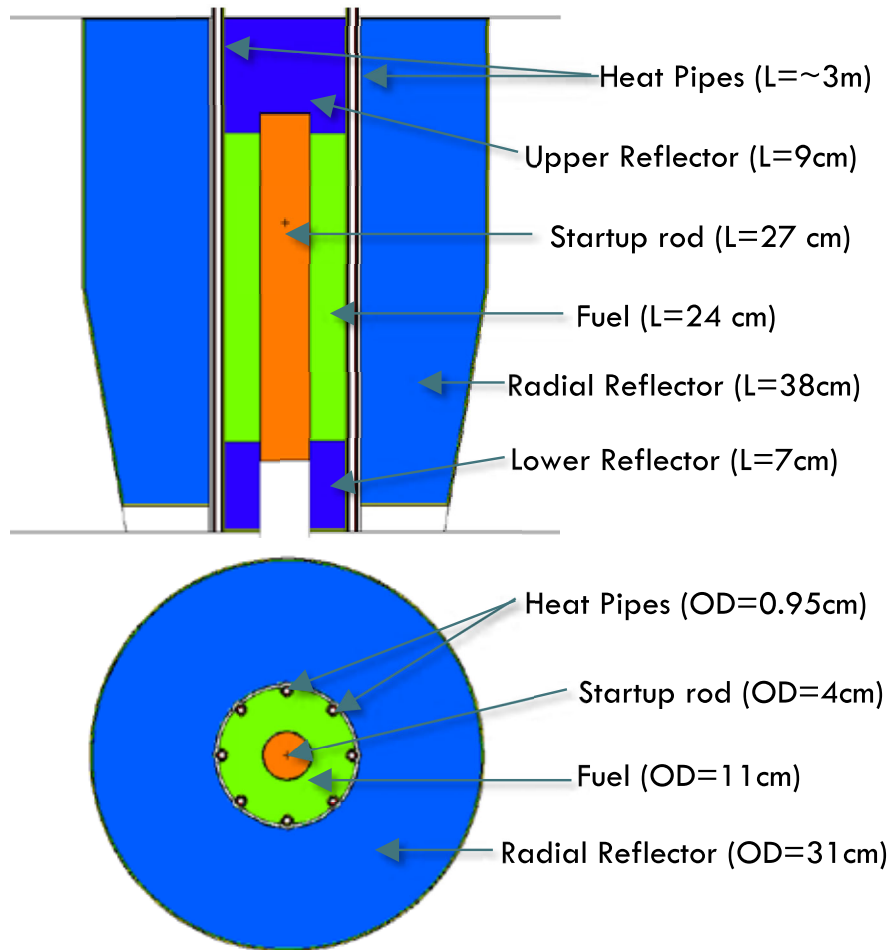

FIGURE 3-15 | NPAS FPS REACTOR CONFIGURATION

There are three primary attributes that contribute to the safety of the FPS reactor concept. These are 1) fixed excess reactivity as required to achieve the design operating temperature, 2) very low starting radiological inventory, and 3) intrinsic design that minimizes the likelihood of criticality under potential accident conditions. A reactor designed with fixed excess reactivity means that the peak reactor temperature is limited by the materials and geometry. During startup, the reactor is brought to temperature slowly to prevent transients that might cause a harmful temperature overshoot. This can be accomplished by gradually removing the startup rod to a final position that could be maintained for the entire mission duration. After the reactor has achieved its operating temperature, the well-established physics associated with negative temperature reactivity feedback will automatically regulate the power output of the reactor to achieve equilibrium between the core reactivity and the power conversion heat removal. During operations, this design feature reduces the likelihood of harmful transients that could cause fuel damage. Like most reactors, the FPS concept has very little initial radiological inventory prior to startup. The core would have about 1.5 curies of radioactivity, primarily from small amounts of U-234 in the unirradiated fuel. Moreover, there would be no fission products or activated materials prior to reactor operation. Finally, the FPS has been designed to remain sub-critical under several commonly analyzed launch accident conditions. Among the cases analyzed was a scenario in which an intact, undamaged core is fully immersed in water or wet sand that could provide reflection and moderation of neutrons. The analysis indicates that the reactor will not achieve criticality unless the startup rod is removed and the reflector remains intact surrounding the core.

3.5.3 | Radiation Shield Description

The FPS reactor shield concept is shown in Figure 3-16. It consists of alternating layers of LiH and DU contained in a one millimeter-thick stainless steel can. The overall thickness is about 52 cm, not including a 5 cm separation gap between the reactor and the first shield layer. The shield is sized to attenuate gamma radiation to less than 25 krad and fast neutron radiation (>1 MeV) to less than 1×10^{11} n/cm² at a 10 m dose plane over a 15-year design life. The total shield mass for the 4.3 kW_{th} reactor is about 170 kg. The shield is shown with direct line-of-sight penetrations for the eight heat pipes, although a more likely design would have the heat pipes bent around the shield to minimize streaming.

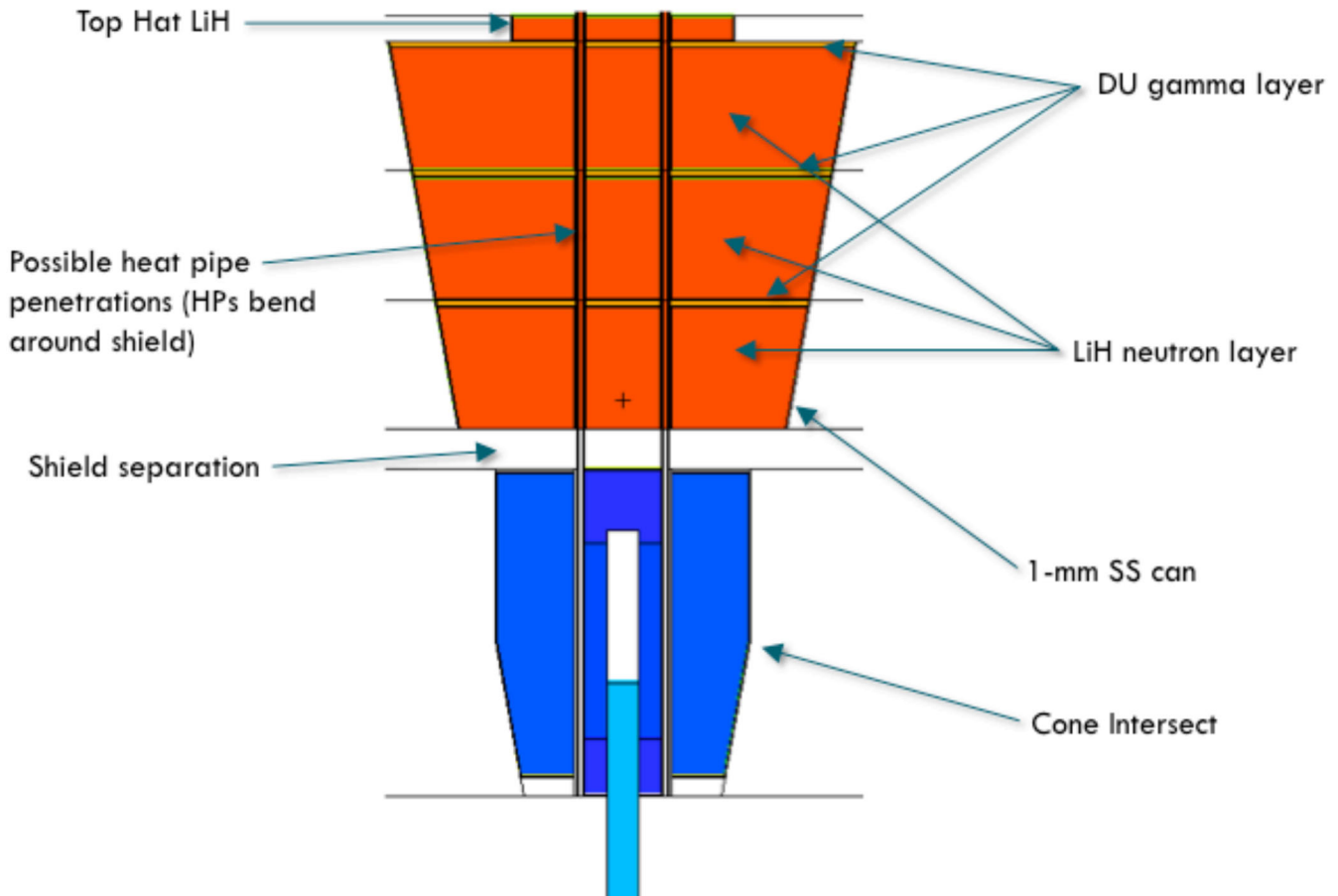

FIGURE 3-16 | NPAS FPS SHIELD CONFIGURATION

3.5.4 | FPS Reactor Scalability

The NPAS effort sought to explore options for scaling FPS up to 10 kW_e. Preliminary analytical studies were performed by LANL using full MCNP-based radiation transport analysis and detailed thermal analysis. Core designs were developed for four different thermal power levels: 4.3 kW_{th}, 13.0 kW_{th}, 21.7 kW_{th}, and 43.3 kW_{th}. The reactor cross-section and heat pipe configuration for the four thermal power levels are presented in Figure 3-17 (note that the layouts are shown with proportional geometry). As the core power increases, the fuel diameter and number of heat pipes also increase. All of these design concepts are sized to allow two heat pipes to fail without compromising core thermal integrity. For reactor thermal power levels greater than 4.3 kW_{th}, the heat pipes must be moved internal to the core and bonded directly to the fuel for proper thermal management. The in-core heat pipes represent an additional technology challenge that must be addressed early in the development effort for the larger cores.

A summary of the key reactor design parameters and estimated mass is presented in Table 3-7. The reactor masses include the core, heat pipes, reflector, and startup rod. These reactor thermal power levels would produce a range of electric power output levels depending on the power conversion choice. For example, when paired with Stirling convertors, the FPS would produce between 1 kW_e and 10 kW_e. When paired with TE power conversion, the FPS would produce between 300 W_e and about 3 kW_e.

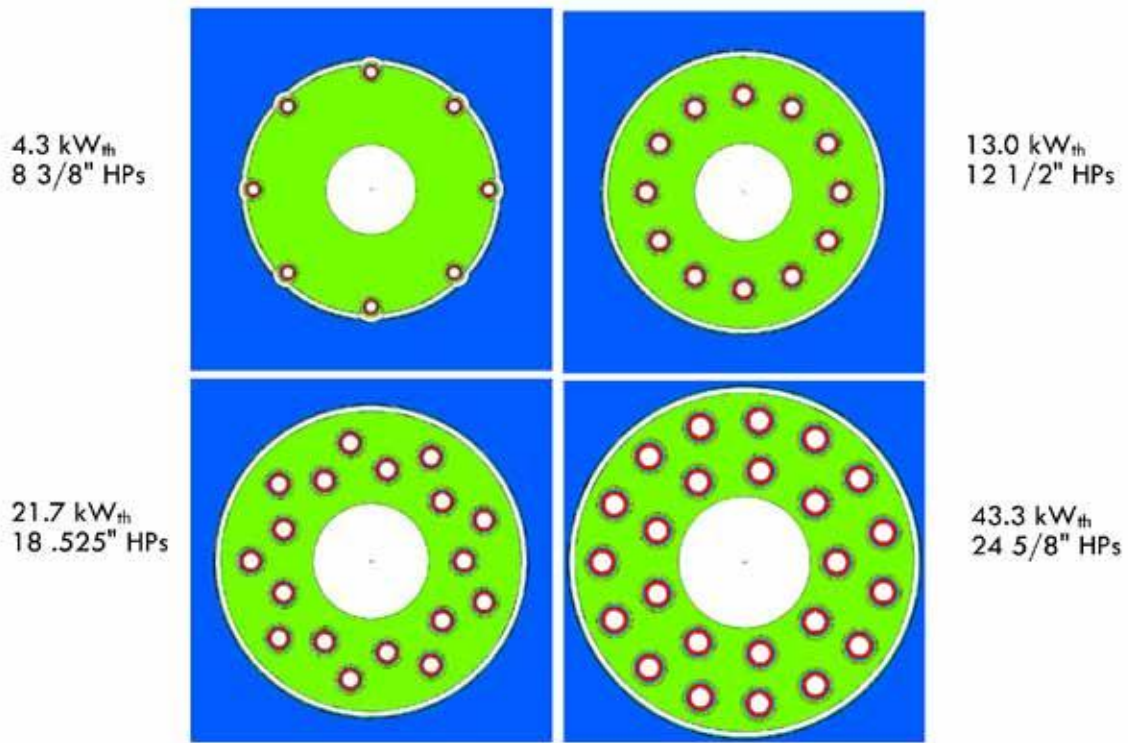

FIGURE 3-17 | NPAS FPS REACTOR CROSS-SECTIONS FOR FOUR THERMAL POWER LEVELS

TABLE 3-7 | REACTOR PERFORMANCE DATA FOR FOUR THERMAL POWER LEVELS

Performance Parameter (kW _{th})	REACTOR POWER (kW _{th})			
	4.3	13.0	21.7	43.3
Full-Power Years	15	15	15	15
Number of Heat Pipes	8	12	18	24
Fuel Burn Up (FIMA)	0.09%	0.22%	0.32%	0.56%
Power Density (W/cc)	2.3	6.0	8.7	15.1
Total U ²³⁵ Inventory (kg)	28.4	32.9	37.9	43.7
Total Reactor Mass (kg)	134.2	157.8	184.4	226.3

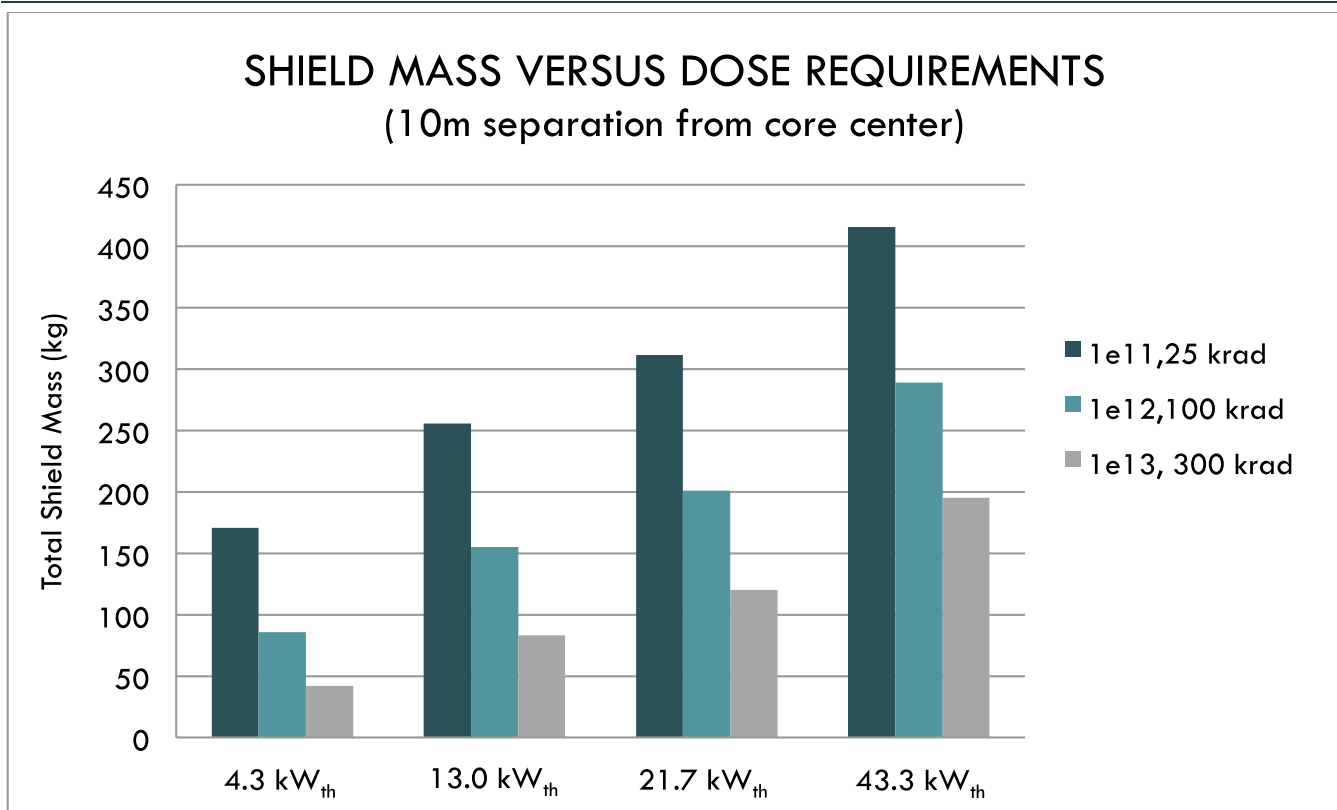

FIGURE 3-18 | PROJECTED SHIELD MASS AS A FUNCTION OF THERMAL POWER AND DOSE

A radiation shield design was developed for each reactor core, based on the assumptions stated in Section 3.5.3. In addition, parametric shielding analysis was performed to determine the mass sensitivity to neutron and gamma dose. Figure 3-18 presents a graphical summary of estimated shield mass versus reactor thermal power assuming low (10^{11} n/cm², 25 krad), medium (10^{12} n/cm², 100 krad), and high (10^{13} n/cm², 300 krad) dose rates at the 10 m dose plane. Note the significant shield mass savings as the radiation dose constraints are relaxed.

In performing the reactor scaling studies, the team determined that there was no inherent limit to the thermal power attainable from a block-fuel reactor that is cooled by heat pipes. However, as with any type of reactor concept, there are trade-offs between thermal power, development risk, performance, and cost. The 4.3 kW_{th} FPS reactor concept takes advantage of numerous simplifications to make development risk relatively low. But as the thermal power increases, external heat pipes are no longer practical and the heat pipes must be embedded in the fuel. This would introduce various reactor fabrication and system integration issues, and could have safety implications. In addition, at higher thermal power levels the increased size of the fuel block may exceed the capacity of existing shipping containers required for the nuclear material.

As the core grows in thermal power level, more and larger heat pipes would be needed in order to maintain thermal design margin. At thermal power greater than 10 kW_{th} a control system would likely be needed to compensate for fuel burn-up during the mission. This would be a simple system and would only be needed to make-up for reactivity loss, so movement would be very infrequent (a few times in 15 years). As thermal powers approach 50 kW_{th} , fuel swelling, creep, and distortion may become a significant engineering issue for UMo alloy fuels, such that a pin-type reactor or a more robust fuel block (e.g. cermet) would be needed. In addition to these projected constraints, many reactor design aspects become more difficult with increasing thermal power level including: reflector/shield thermal management, nuclear ground testing, required/achieved control worth, as well as launch and reentry accident safety.

3.5.5 | Alternative FPS Concepts

There was not consensus on the System Study Team regarding the FPS concept as the NPAS reference reactor approach. During the study, a range of concerns was expressed relative to the proposed FPS reactor design and technology basis. These concerns included scalability, security, testability, launch and reentry safety, reliability, lifetime, and unit cost as it might impact multi-unit missions (e.g. HEOMD Mars surface missions). Some team members believed that there had not been sufficient design work and independent review to reach a defensible conclusion on reactor choice. Additionally, there are alternative concepts that may provide a better path to future small FPS. One candidate would be a moderated reactor such as a SNAP derivative design using UZrH or UYH, which would require considerably less HEU with greatly reduced security requirements. Other concepts were also discussed among the System Study Team including reactor fuel systems that use U-235 in UO₂, UN, and UC, as well as a concept that uses U-233.

Nevertheless, results of the study were believed to be sufficient to provide representative ROM cost estimates and notional development schedules, with technical issues and design requirements to be addressed in a future design evaluation. It was suggested by some team members that the next step should be a comprehensive study of potential requirements for future small fission systems, and an evaluation of a range of concepts and technologies be made against those requirements. This differs from the FPS approach in which a specific technology solution is advanced through hardware demonstration to inform mission requirements planning and performance expectations.

3.5.6 | FPS Observations

STMD is funding a KiloPower Technology Development Project in cooperation with DOE through a three-year, \$5 million/year project that will culminate with a nuclear-heated technology demonstration test at DAF. By maintaining a simple design and restricting the thermal power level, the KiloPower concept can be evaluated in existing DOE and NASA test facilities prior to implementing a flight development effort. The flight-specific system and mission integration aspects and overall development cost will remain cursorily defined until the STMD technology effort is completed. Its potential use in HEOMD Mars surface application will also depend on further requirements development and concept assessment.

The KiloPower concept represents a novel approach to developing an initial space reactor capability for NASA. The fast-spectrum, highly reflected HEU core provides a low mass, compact system that is relevant to planetary spacecraft applications. At the 1-kW_e level, it can be combined with either TE or Stirling power conversion options that are already being developed for RPS. The concept has also been shown to offer favorable scaling characteristics to permit its use at power levels up to 10 kW_e. This power level may be suitable for future HEOMD Mars surface missions in which multiple units could be employed to satisfy a 35–40 kW_e total power requirement, if that architecture is shown to be cost effective [122] and the concept can be shown to meet HEOMD mission requirements.

FPS are not an ideal solution for all space science missions. Their relatively large size and mass make them impractical for anything smaller than Flagship-class orbiters. The reactor-induced radiation presents a potential challenge for the spacecraft electronics and science payload, requiring heavy shielding and special spacecraft packaging to avoid radiation damage to sensitive equipment. FPS also introduce additional, and potentially costly, security measures that must be considered when transporting and processing the system for launch.

An important FPS assumption is that the fuel supply is based on adequate quantities of available, excess HEU that is provided at no cost to a NASA mission from the DOE. The only direct cost to a mission related to the reactor fuel is associated with the fabrication, inspection, and delivery of the core. It was also assumed for the study that the fuel can be manufactured and tested in existing DOE facilities with infrastructure that is currently maintained by DOE for other customers, but additional FPS reactor and fuel capabilities would be

needed for a sustained effort (see Section 5.6.3). FPS also offer the characteristics of low radiological inventory at launch and the ability to start the reactor after the system is in a safe operating environment.

3.5.7 | Possible Near-term FPS Forward Work

The first step toward establishing the KiloPower concept as a viable space FPS option is the successful completion of the STMD Technology Development Project. The project will focus on thermal prototype and separate-effects materials testing, non-nuclear and nuclear system-level²⁴ technology testing as shown pictorially in Figure 3-19 [123]. The thermal prototype testing will evaluate thermal cycling effects, and verify heat pipe thermal interfaces and mechanical attachment methods. The materials testing will generate data to understand orthotropic thermal expansion characteristics and creep properties of the DU-Mo alloy. The non-nuclear integrated test will assemble an electrically heated DU core with sodium heat pipes and Stirling power convertors in a configuration mimicking a notional flight design. The objective will be to evaluate integrated thermal performance and characterize system dynamics in a thermal-vacuum environment.

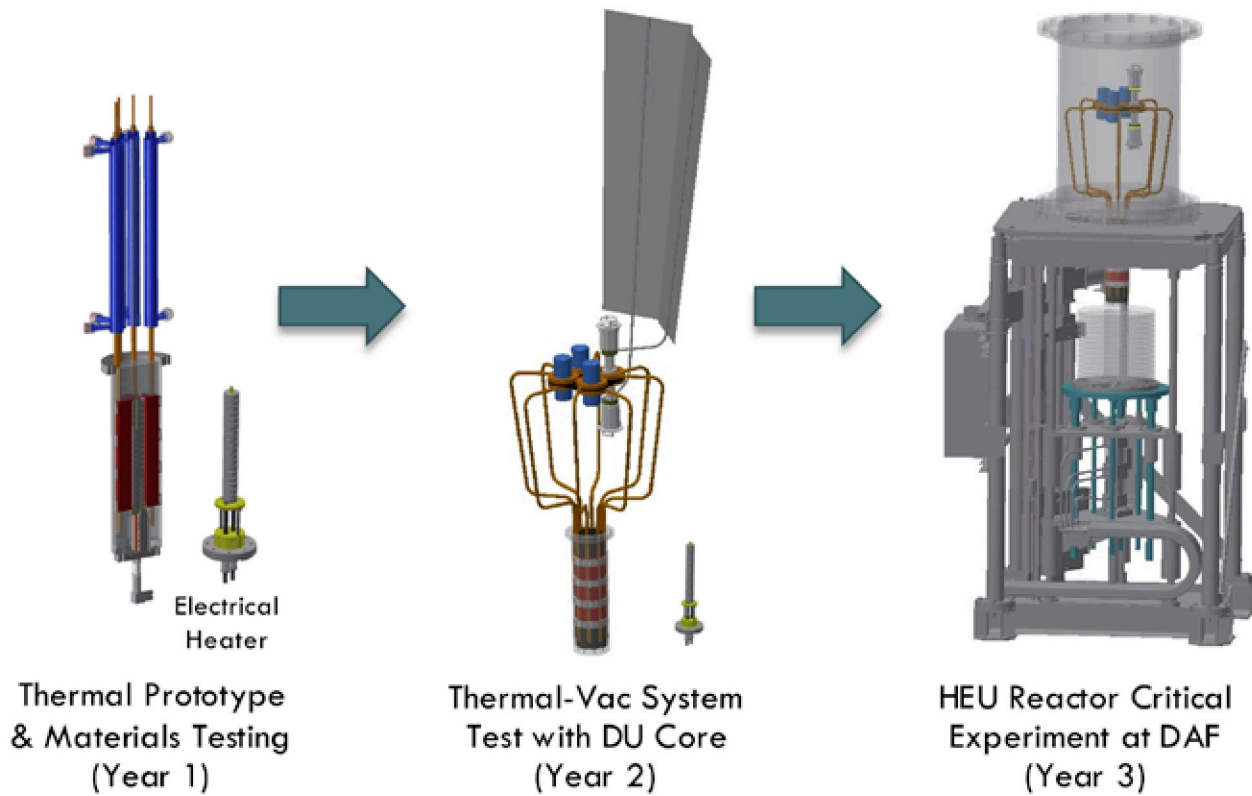

FIGURE 3-19 | STMD KILOPOWER TECHNOLOGY DEVELOPMENT PROJECT

The technology demonstration will conclude with a nuclear-heated demonstration test at DAF using the existing COMET critical experiments machine. A full-scale, prototypical HEU core will be installed in place of the DU core from the non-nuclear test, while retaining the heat pipes and Stirling convertors. The HEU core and balance of plant will be contained in a thermal-vacuum chamber that rests on the top of COMET. An assembly of BeO annular disks will be placed on the moving pedestal to permit the system to reach criticality. The goals of the test include verification of the excess reactivity and neutronic performance of the core, verification of the overall thermal performance, characterization of the startup/shutdown sequence, and successful demonstration of electrical power generation from nuclear heat.

²⁴ In this context, system-level refers to an assembly of the key components needed to demonstrate component interfaces and power generation from nuclear heat in a relevant environment.

3.6 | Infrastructure and Fuel Availability

3.6.1 | RPS DOE Infrastructure [124,125]

DOE provides a unique capability for supplying power systems that function in remote or hostile environments. This capability has been provided since the early 1960s and DOE counts NASA as one of its most prominent customers. This capability is one-of-a-kind in the world in terms of its experience (over five decades), number of missions supported (over two dozen to date), and range of power levels (watts to hundreds of watts).

The heart of every RPS is a plutonium dioxide heat source. Spontaneous radioactive decay of plutonium-238 produces 0.56 watts of thermal energy per gram of the isotope; Pu-238 has a half-life of 87.7 years. The heat produced is either used directly in the form of thermal energy or used to power a converter that produces electricity. For systems that supply electricity, plutonium dioxide is processed and assembled into fueled clads, and then assembled into the standard building blocks used in today's RPS, the General Purpose Heat Source (GPHS) module, depicted in Figure 3-20. The required number of GPHS modules needed to provide the mission's electrical power is then assembled into the converter to make up the RPS. The latest NASA mission to land on Mars, the Curiosity Mars rover, uses eight GPHS modules inside its MMRTG to provide electricity and heat to the rover since its launch in November 2011. Before that, the Pluto-New Horizons spacecraft launched in January 2006 with an RPS containing 18 GPHS modules.

SDPS operates complex process development and production facilities at three national laboratories – Los Alamos National Laboratory (LANL), Oak Ridge National Laboratory (ORNL), and Idaho National Laboratory (INL) – and maintains the personnel and hardware necessary to support NASA launch activities for RPS-equipped missions. Sandia National Laboratories (SNL) has a significant role in SDPS in planning safety verification tests for heat sources, and for performing safety analyses for NASA missions. DOE performs a number of activities to support successful launches for NASA missions, such as ground support operations at KSC, NEPA analyses, radiological contingency planning, nuclear safety and security, and risk communications. The RPS infrastructure can be characterized as a geographically dispersed collection of equipment and highly trained technical staff at DOE, NASA, KSC, and several national laboratories organized to perform a sequential process, with no redundancy of key functions, as depicted in Figure 3-21.

ORNL produces carbon-bonded/carbon-fiber (CBCF) insulator sleeves, which provide thermal insulation for the GPHS fueled clads installed in the GPHS modules. ORNL also produces the special iridium-alloy metal containment, or clad vent sets, for the plutonium dioxide fuel pellets manufactured at LANL. ORNL ships these sets to LANL, where they are used to encapsulate the fuel pellets. LANL then ships the resulting encapsulated pellets (GPHS fueled clads) to INL where they are inserted into graphite components to form GPHS modules. The modules are then inserted into converters to form RPS. ORNL produces platinum-rhodium alloy metal clads and ships them to LANL for use in encapsulating very small plutonium oxide pellets, which are ultimately used to fabricate the Light Weight Radioisotope Heater Unit (LWRHU), depicted in Figure 3-22. NASA uses the LWRHUs for warming critical components, instrumentation, lubricating fluids, and thruster fuel during planetary space exploration missions and some Earth-orbiting missions.

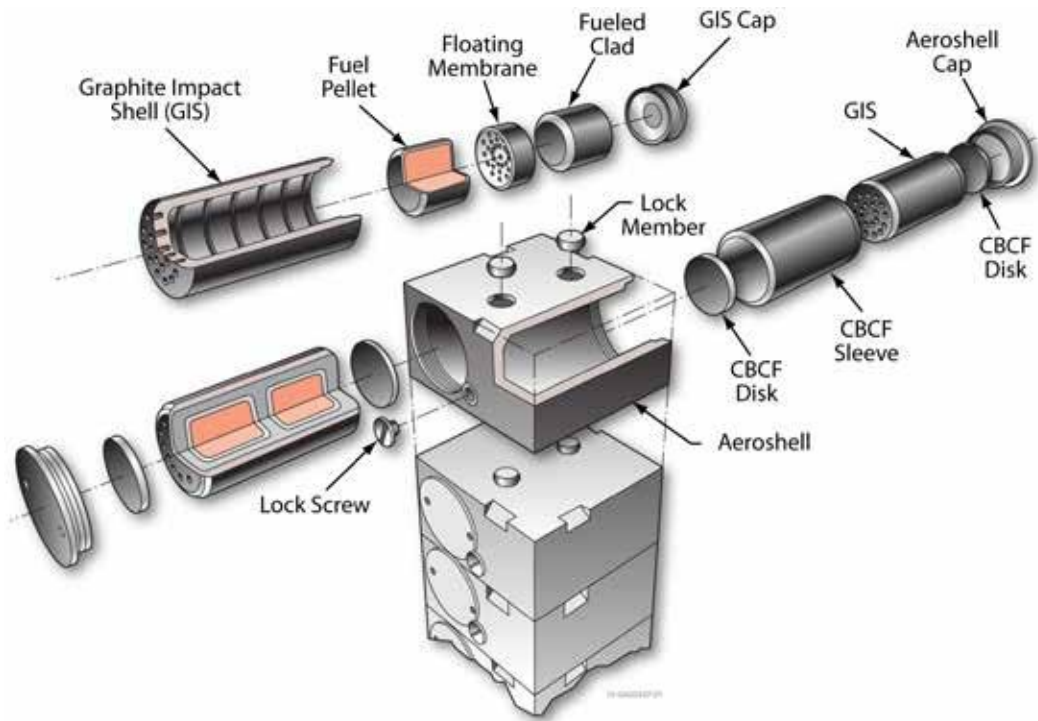

FIGURE 3-20 | GENERAL PURPOSE HEAT SOURCE MODULE

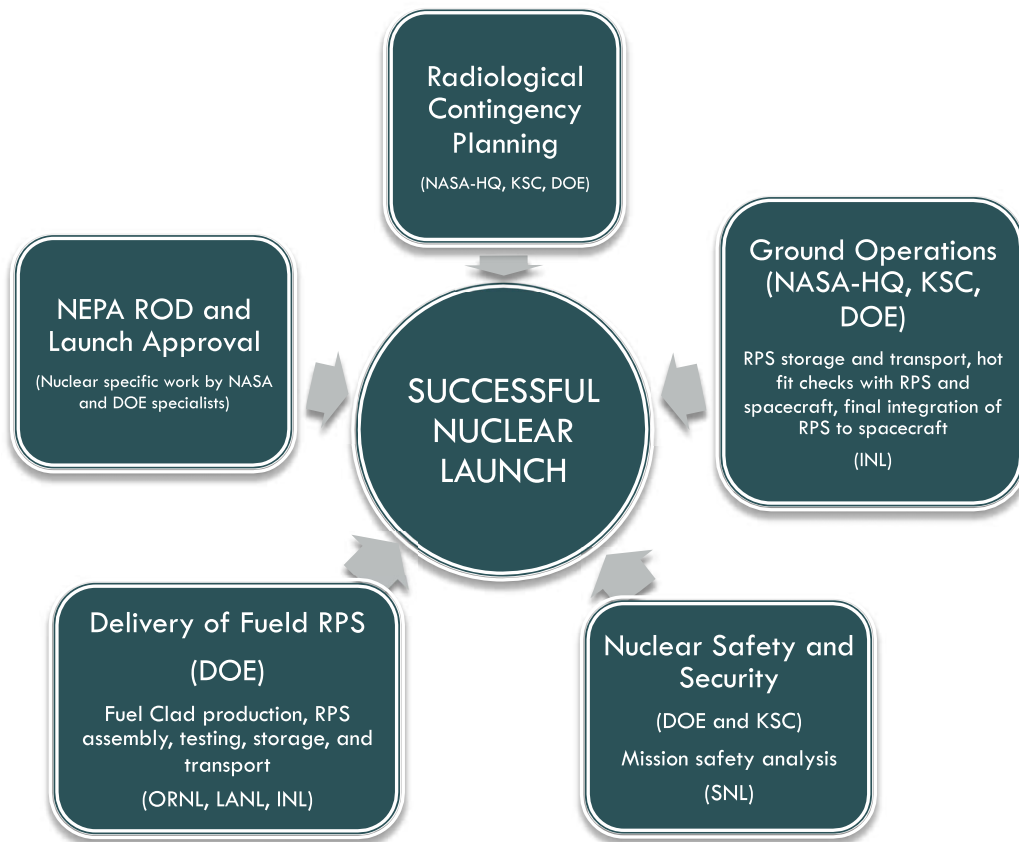

FIGURE 3-21 | DOE ROLE IN NASA NUCLEAR LAUNCHES

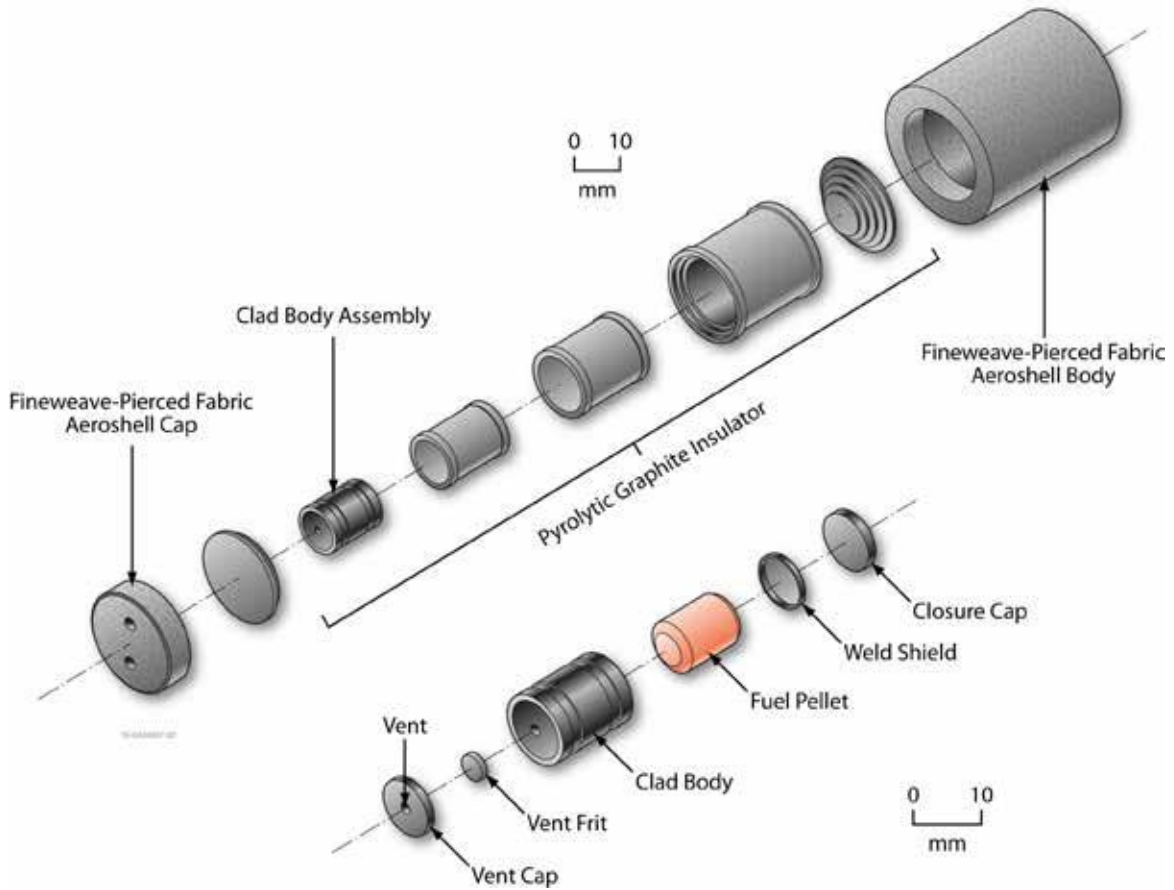

FIGURE 3-22 | LIGHT WEIGHT RADIOISOTOPE HEATER UNIT



FIGURE 3-23 | AQUEOUS PROCESSING GLOVEBOX LINE AT LANL

At LANL, plutonium dioxide undergoes a purification process to remove decay products and other impurities, if necessary. It is then converted into an oxide form, pressed into ceramic pellets, and encapsulated in clad vent sets supplied by ORNL. Both the fueled clads for GPHS modules and for LWRHUs are fabricated at LANL. All processing of plutonium dioxide must take place in tightly sealed gloveboxes maintained under negative pressure to ensure no leaks of fuel into the workspaces. Figure 3-23 shows the aqueous processing glovebox

line at LANL, one of several glovebox lines used there to fabricate the fueled clads. After final inspection and acceptance of the fueled clads, LANL ships them to INL. LANL also performs safety verification testing of fueled clads and modules in support of launch safety, and it provides safe, secure storage of the majority of the existing U.S. plutonium dioxide supply.

INL is responsible for assembly, testing, storage, and transportation of RPS to user destinations and ground support at KSC in Florida. At INL's Space and Security Power Systems Facility (SSPSF), fueled clads are received from LANL and assembled into graphite module components to form the GPHS modules. The modules are then assembled into converters to become RPS. SSPSF houses three different gloveboxes where RPS can be assembled. The Inert Atmosphere Assembly Chamber (IAAC), shown in Figure 3-24, is one of the three gloveboxes at INL used for RPS assembly and Figure 3-25 shows the MMRTG being assembled in the IAAC. After assembly, each RPS is put through a series of tests to simulate various launch and flight conditions. These include vibration, magnetic, mass properties, and thermal vacuum testing. One of the two thermal vacuum chambers is shown in Figure 3-26. Then the RPS are stored until at SSPSF they are transported to KSC. The SSPSF is dedicated solely to SDPS activities. INL manages the various types of Type B-certified casks in which the fueled clads and the completed RPS are transported. Once transported (typically around four to six months prior to launch), INL provides support to ground operations through launch, including implementation of the DOE nuclear safety rules and regulations required whenever certain quantities of radioactive materials are stored or used. Figure 3-27 shows the 9904 RPS shipping cask in one of the facilities used to store RPS at KSC. Finally, INL serves as the lead laboratory for SDPS, providing technical integration and coordination of material reviews and configuration control reviews for the RPS infrastructure.

SNL supports the DOE SDPS Program as the lead for safety analysis capabilities. A suite of codes exist to handle the diverse phenomena associated with safety analyses for nuclear launches, including blast and impact, propellant fires, atmospheric re-entry, diverse accident sequences, atmospheric transport and consequences, and probabilistic modeling and risk determination.



FIGURE 3-24 | IAAC AT INL'S SPACE AND SECURITY POWER SYSTEMS FACILITY



FIGURE 3-25 | MMRTG BEING ASSEMBLED IN IAAC



FIGURE 3-26 | THERMAL VACUUM CHAMBER AT INL'S SPACE AND SECURITY POWER SYSTEMS FACILITY



FIGURE 3-27 | 9904 RPS SHIPPING CASK IN RADIOISOTOPE THERMOELECTRIC GENERATOR FACILITY AT KSC

3.6.2 | Plutonium-238 Fuel Production

This section provides a projection for RPS availability using various scenarios involving varying rates for production of new Pu-238, varying types of RPS, and varying mission scenarios. The first parameter to be varied is the production rate for Pu-238. Three cases are analyzed: 1.5, 3.0, and 5 kg/year of plutonium dioxide are assumed to be produced by ORNL. The first newly produced material is assumed to be available one year after the latest currently projected project end date (essentially the start of fiscal year 2023). It is also assumed to be a steady operation with the total fuel available at the end of a given year, with no production variability or “sprint mode” operations.

Two types of future RPS are considered: 1) the Advanced Radioisotope Thermoelectric Generator (ARTG), which is assumed to use 16 GPHS modules, each containing four fueled clads (FC), resulting in a total of 64 FCs per ARTG; 2) the 6-GPHS SRG, for a total of 24 FCs per SRG. Finally, it was assumed all existing plutonium dioxide inventory was used by prior missions, so only newly produced fuel was considered in the analysis. The prior missions include using one MMRTG for Mars 2020, five MMRTG for a potential Europa mission, and one MMRTG for a potential Discovery or New Frontiers mission. At the time that this study was conducted, this assumption was plausible given the mission set under consideration by PSD. However, shortly after the conclusions of NPAS, the Europa Clipper project determined the mission concept’s science objectives could be met using solar power. This change would considerably affect this analysis.

The Pu-238 supply project is expected to start full production no later than the summer of 2021. The current projected production rate of ~ 1.5 kg of plutonium dioxide per year is conservatively equal to 9 FCs/year rate, allowing for some material loss during aqueous clean up after shipment from ORNL to LANL. Table 3-8 and Table 3-9 are intended to convey when the cumulative FCs are sufficient to produce a fueled power system, either 16-GPHS ARTG or 6-GPHS SRG. Time is allocated in the schedule for the following actions: 1) shipment of the material from ORNL to LANL, 2) accumulation of enough material at LANL to allow for efficient aqueous processing, batch processing of plutonium dioxide powder and encapsulation into iridium hardware, 3) shipment of the heat sources to INL, 4) processing of the heat sources into modules and subsequent fueling and testing of the RPS when enough FCs are available to do this, and 5) shipment of the system to the launch facility 4-6 months prior to launch. These schedule accommodations explain why the first FCs noted in the tables are shown in 2024 even though they represent material produced at ORNL in 2021-22.

Table 3-9 show when either 16-GPHS ARTGs or 6-GPHS SRGs, respectively, would be available for launch. Each row in these tables provides the number of FCs, GPHS modules, and RPS per year that could be available based on production rates set at 1.5, 3.0, or 5.0 kg per year. The table is color coded to allow the reader to track the progress of GPHS modules available for RPS. When there are not enough FCs to produce a GPHS module, the extra FCs are shown with a +. For example, in Table 3-8, in fiscal year 2026, for the 1.5 kg per year production rate, there are 11 FCs shown. Given that in any one year, nine FCs would be fabricated, the 11 FCs shown are possible due to the +2 FCs that were not used in 2025 in a GPHS module. Those 11 FCs are used to fabricate two GPHS modules, requiring eight FCs, with an additional three FCs left available to use in fiscal year 2027. When enough GPHS modules are fabricated to fuel a RPS, the quantity and type of RPS is called out in the column. For example, in Table 3-8, in fiscal year 2027 at the 3 kg per year production rate, one 16-GPHS ARTG can be fueled and available for launch. This is denoted in the Table with the label 1 ARTG #1. In fiscal 2031, the second 16-GPHS ARTG is available for flight, labeled 1 ARTG #2. Section 3.6.3 addresses the feasibility of increasing the fuel production rate.

TABLE 3-8 | 16-GPHS ARTG AVAILABILITY BASED ON PU-238 PRODUCTION RATE VARIATIONS

Pu-238 Oxide Production Rate	Available Component	FY 2024	FY 2025	FY 2026	FY 2027	FY 2028	FY 2029	FY 2030	FY 2031	FY 2032
1.5 kg/yr (9 FC/yr)	# of FC	9 FC =	10 FC =	11 FC =	12 FC =	9 FC	10 FC =	11 FC =	12 FC =	9 FC =
	# of Module(s) possible given FC available	2 Mod	2 Mod	2 Mod	3 Mod	2 Mod	2 Mod	2 Mod	1 Mod + 2 Mod	2 Mod
	Left over FC	+ 1 FC	+ 2 FC	+ 3 FC		+ 1 FC	+ 2 FC	+ 3 FC		+ 1 FC
	# ARTG(s) Available								1 ARTG #1	
3.0 kg/yr (18 FC/yr)	# of FC	18 FC =	20 FC =	18 FC =	20 FC =	18 FC =	20 FC =	18 FC =	20 FC =	18 FC =
	# of Module(s) possible given FC available	4 Mod	5 Mod	4 Mod	3 Mod + 2 Mod	4 Mod	5 Mod	4 Mod	1 Mod + 4 Mod	4 Mod
	Left over FC	+ 2 FC		+ 2 FC		+ 2 FC		+ 2 FC		+ 2 FC
	# ARTG(s) Available				1 ARTG #1				1 ARTG #2	
5.0 kg/yr (30 FC/yr)	# of FC	30 FC =	32 FC =	30 FC =	32 FC =	30 FC =	32 FC =	30 FC =	32 FC =	30 FC =
	# of Module(s) possible given FC available	7 Mod	8 Mod	1 Mod + 6 Mod	8 Mod	2 Mod + 5 Mod	8 Mod	3 Mod + 4 Mod	8 Mod	4 Mod + 3 Mod
	Left over FC	+ 2 FC		+ 2 FC		+ 2 FC		+ 2 FC		+ 2 FC
	# ARTG(s) Available			1 ARTG #1		1 ARTG #2		1 ARTG #3		1 ARTG #4

64 Fueled Clads (FC) = 16 GPHS Modules (Mod) = 1 ARTG

TABLE 3-9 | 6-GPHS SRG AVAILABILITY BASED ON PU-238 PRODUCTION RATE VARIATIONS

Pu-238 Oxide Production Rate	Available Component	FY 2024	FY 2025	FY 2026	FY 2027	FY 2028	FY 2029	FY 2030	FY 2031	FY 2032
1.5 kg/yr (9 FC/yr)	# of FC	9 FC =	10 FC =	11 FC =	12 FC =	9 FC =	10 FC =	11 FC =	12 FC =	9 FC =
	# of Module(s) possible given FC available	2 Mod	2 Mod	2 Mod	3 Mod	2 Mod	1 Mod + 1 Mod	2 Mod	3 Mod	2 Mod
	Left over FC	+ 1 FC	+ 2 FC	+ 3 FC		+ 1 FC	+ 2 FC	+ 3 FC		+ 1 FC
	# SRG(s) Available			1 SRG #1			1 SRG #2		1 SRG #3	
3.0 kg/yr (18 FC/yr)	# of FC	18 FC =	20 FC =	18 FC =	20 FC =	18 FC =	20 FC =	18 FC =	20 FC =	18 FC =
	# of Module(s) possible given FC available	4 Mod	2 Mod + 3 Mod	3 Mod + 1 Mod	5 Mod	4 Mod	2 Mod + 3 Mod	3 Mod + 1 Mod	5 Mod	4 Mod
	Left over FC	+ 2 FC		+ 2 FC		+ 2 FC		+ 2 FC		+ 2 FC
	# SRG(s) Available		1 SRG #1	1 SRG #2	1 SRG #3		1 SRG #4	1 SRG #5	1 SRG #6	
5.0 kg/yr (30 FC/yr)	# of FC	30 FC =	32 FC =	30 FC =	32 FC =	30 FC =	32 FC =	30 FC =	32 FC =	30 FC =
	# of Module(s) possible given FC available	6 Mod + 1 Mod	5 Mod + 3 Mod	3 Mod + 4 Mod	2 Mod + 6 Mod	6 Mod + 1 Mod	5 Mod + 3 Mod	3 Mod + 4 Mod	2 Mod + 6 Mod	6 Mod + 1 Mod
	Left over FC	+ 2 FC		+ 2 FC		+ 2 FC		+ 2 FC		+ 2 FC
	# SRG(s) Available	1 SRG #1	1 SRG #2	1 SRG #3	1 SRG #4 1 SRG #5	1 SRG #6	1 SRG #7	1 SRG #8	1 SRG #9 1 SRG #10	1 SRG #11

24 Fueled Clads (FC) = 6 GPHS Modules (Mod) = 1 SRG

3.6.3 | Potential for Increasing Pu-238 Production Rate

This section addresses the prospects for increasing the production rate for new Pu-238 above the planned average rate of 1.5 kg of plutonium dioxide per year. The planned production rate is based on NASA’s projected mission needs and funding availability. For the purpose of comparison, production rates of 1.5, 3.0, and 5.0 kg/year were considered.

Several factors can be considered in order to increase production beyond 1.5 kg/year. The current Pu-238 Supply Project includes value studies to identify any areas where production can be optimized at minimal cost. A clear understanding of the potential effectiveness of such measures, or of any future expansion approach, depends on first completing the project’s technology demonstration work currently in progress. Key factors yet to be finalized include: 1) what rate will actually result from the base capability, except that 1.5 kg per year is minimum; 2) what the sensitivity around that rate will be and what steps would be needed to improve it; 3) what “sprint capability” might exist within the base capability; 4) what isotopic assay can be achieved with the base capability or with any improvement options; or 5) what combination of improvements would be selected for any given future production need. Changes that could be considered, if increased

production were to become necessary, include process improvements or equipment upgrades, target design changes, use of additional target locations in the Advanced Test Reactor (ATR) at INL, and outfitting and startup of a currently unused hot cell at ORNL that would require an investment on the order of approximately \$100 million. Each of these changes has ramifications, including additional tests, costs and schedule impacts, and non-uniform technology readiness levels and risks between the various ideas proposed.

It is very likely that several changes, including outfitting and startup of the currently unused hot cell, would need to be implemented to improve the production rate to 5 kg/year, but smaller increases may be possible with less investment. NASA and DOE have options to consider that would build flexibility into supporting future mission rates. One option is to pursue a new system design to improve efficiency; another option is to increase the Pu-238 production rate. In addition to cost as a factor in this trade, the relative risk and sustainment factors of these choices also need to be considered. However, the trade is not “either/or” but a spectrum that needs optimization using a more rigorous systems engineering analysis, after the currently planned production capability is better understood (in another year or two). Significant investments to increase Pu-238 production or to develop a new system to increase conversion efficiency should only be made in response to some known NASA mission need for more mission power than is currently expected. Currently, whether using the MMRTG or proposed eMMRTG, the forecasted demand is not known to exceed supply projections, so any investment should support a change in the foreseeable need.

3.6.4 | Impact of Pu-238 on Mission Power

Matching NASA’s mission needs to the current inventory and future production of Pu-238 is crucial to assure RPS program responsiveness. An analysis was performed to evaluate the mission power that can be generated with the new Pu-238 that is being produced. The analysis considered the maximum mission power that can be produced as a function of time for a range of RPS technology options. The NPAS effort assumed all of the currently available fuel has been consumed in upcoming SMD missions or obligated for upcoming mission solicitations. The new production capability for plutonium dioxide is planned to be available no later than summer 2021, after which material may be produced at an average rate of 1.5 kg per year (the 1.5 kg of plutonium dioxide equates to about 1.1 kg of Pu-238 isotope). For the purpose of this analysis it was assumed that the first fueled clads, could be available early in calendar year 2023.

Figure 3-28 shows the End of Mission (EOM) DC power output that could be produced from the 1.5 kg/year plutonium dioxide supply for four RPS technology options: MMRTG, eMMRTG, 16-GPHS ARTG, and 6-GPHS SRG. EOM is defined as 17 years after fueling of the RPS (three years storage + 14 years of mission time). The efficiency and degradation rates for the four RPS technologies were based on inputs received from technology experts, and are consistent with the values used in the NPAS mission studies. The data provides a forecast on the cumulative electrical power output that can be deployed based on fuel availability, power conversion efficiency, and system degradation (including the 0.8% per year isotope decay).

Figure 3-28 highlights the benefits of technologies that provide higher efficiency and lower power conversion degradation. If SMD were to rely solely on MMRTG technology, 25 years of new Pu-238 production would limit the total EOM power that could be deployed for all missions to about 300 W_e. The eMMRTG would effectively double the total EOM power output in 25 years to about 600 W_e. 16-GPHS ARTG technology provides a 4 fold improvement over MMRTG, with the possibility to supply missions with nearly 1200 W_e EOM power after 25 years of new Pu-238 production. The 6-GPHS SRG offers the greatest return from the new Pu-238, with a total EOM power output of over 3000 W_e after 25 years of new production. The 16-GPHS ARTG and 6-GPHS SRG curves in Figure 3-28 also show data markers that represent the frequency at which the new 16-GPHS ARTGs and 6-GPHS SRGs could be fueled. By the year 2050, NASA could deploy about three 16-GPHS ARTGs (1050 W_e EOM) or ten 6-GPHS SRGs (3000 W_e EOM).

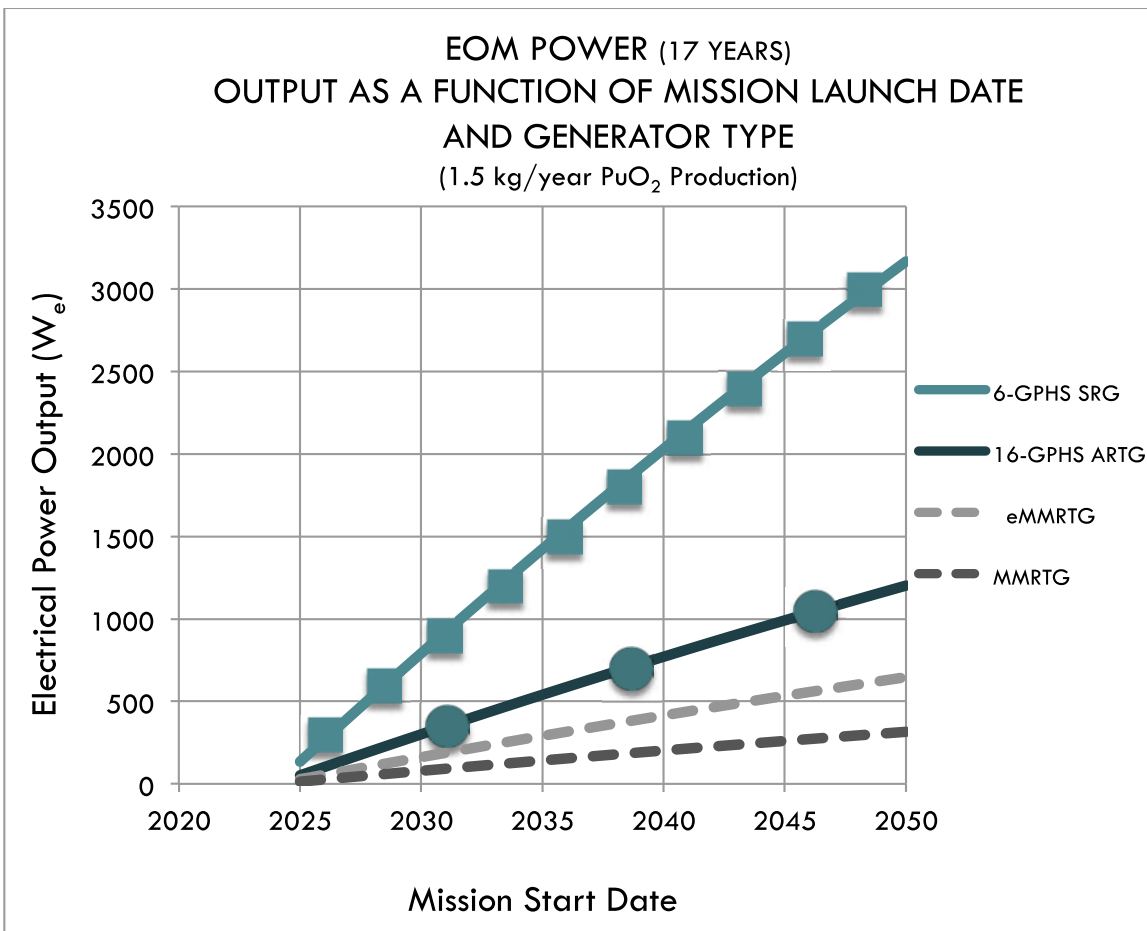

FIGURE 3-28 | IMPACT OF PU-238 PRODUCTION ON MISSION POWER

3.6.5 | HEU Availability and Observations

In 2005, DOE completed a review of the highly enriched uranium (HEU) operations at the Y-12 National Security Complex. The review also evaluated how best to use HEU that would become available from reductions in the nuclear weapons stockpile. Based on this review, the administrator of the National Nuclear Security Administration (NNSA) declared that, in coming years, up to 200 metric tons of HEU will be removed from any future use as fissile material for nuclear warheads.

The majority of the material has been, or will be, freed up from past or planned nuclear warhead dismantlement. There were several categories specified for future use and disposition of this HEU as it became available. These categories included the designation of 160 metric tons for use in Navy nuclear propulsion reactors; the designation of 20 metric tons to be down-blended to low enriched uranium (LEU) for use in power reactors, research reactors, or related research; and, about 20 metric tons of HEU for use in isotope production and, space and research reactors that currently employ HEU.

A memorandum of agreement (MOA) was completed in 2006 among the DOE Offices of Defense Programs, Naval Reactors, Defense Nuclear Nonproliferation, and Nuclear Energy, Science and Technology. The MOA establishes three distinct material inventory accounts for effective planning and control of the HEU; describes the process to assign materials to the management accounts; defines the process to manage changes to the accounts; requires an annual reconciliation and update for the accounts; and describes the process to coordinate and obtain approval of plans and activities involving the use and disposition of the material.

The *Research and Space Reactors* account is for HEU materials currently in use or reserved for U.S. research, medical isotope production, and future space reactors. If material placed in this group is determined to be no

longer required by the research, medical isotope production, or space reactor programs, the material will be re-categorized as material for down blending. There is approximately 20 metric ton of HEU that will be removed from weapon use over the coming years and placed in the *Research and Space Reactors* account. An amount has been set aside for each program element, and those quantities are identified as Official Use Only information and are not publicly available.

The space reactor set-aside is a small fraction of the 20 metric ton set aside for *Research and Space Reactors*. It is important to note that the HEU reserve for space reactors is to be shared across any and all Federal agencies that may have need of a space reactor. The set-aside is modest if all potential federal uses for space reactors are considered including NASA planetary science, surface power, space propulsion and national security uses. The DOE Office of Nuclear Energy is responsible for management of the space reactor reserve.

Additions to the space reactor set-aside would depend on a reprioritization within the *Research and Space Reactors* account or additional HEU being released for non-military applications. However, there can be no guarantee that additional HEU will be allocated for such purposes in the future. Therefore, HEU forecasts should be based on highly probable program needs and allotment requests should represent a specific need to achieve program goals. To achieve this goal, HEU forecasts and allotments must be closely coordinated among the responsible NASA mission directorate, the responsible DOE program office and the NNSA Lead Materials Management Organization. The amount of HEU required to provide NASA mission power needs should be a factor of consideration in reactor fuel selection and reactor design.

3.6.6 | FPS Ground Testing Facilities

The facilities considered for NPAS were based on past FPS studies and the current STMD KiloPower Technology Development Project. This project will use the Nevada Nuclear Security Site (NNS) and the former Nevada Test Site as the location for nuclear testing. The NNS has attributes and infrastructure that make it the ideal site for space reactor testing. These attributes include a long distance to the site boundary for public access greatly enhancing safety; a “brown” field site whose overall characteristics will not change in the unforeseen event of an accident; and, existing Security Category 1, Hazard Category 2 nuclear facilities.

One of the key facilities at NNS is the Device Assembly Facility (DAF), shown in Figure 3-29. DAF houses a collection of general purpose critical experiment machines capable of subcritical, delayed, and super-prompt critical operations using large quantities of special nuclear material. One of these machines, COMET, will be used in the KiloPower project for the nuclear demonstration experiment. DAF has existing regulatory and NEPA documentation that is very compatible with testing small kilowatt-class reactors. Most kilowatt-class reactors have very low decay heat (10s to 100s of thermal watts), such that fuel melting can be precluded using natural convection. Reactors in this size range also have negligible fission product generation during testing, so radioactive dose from a potential accident would be small. These design aspects suggest that small reactors would fit into the current regulatory system.

The NNS also has the ability to conduct reactor testing at higher power levels or for longer durations. NNS has an existing underground nuclear facility, known as U1A. This facility would be ideal for higher power nuclear reactors, where there would be a greater concern associated with decay heat and potential radiation dose from an accidental fission product release. This facility would provide sufficient containment in the event of an accident. The facility also has current NEPA documentation that allows for nuclear material to be abandoned in place after a test. Although this feature has never been exercised for a fission reactor, it could allow the reactor to be cemented in place as an effective means of disposal after testing.

Irradiation test facilities and capabilities in the United States have decreased dramatically since the 1990 assessment. The remaining operational test reactors are the Advanced Test Reactor at INL and the High Flux Isotope Reactor at ORNL. There are currently no fast spectrum test reactors operational in the United States.

The primary challenge in irradiation test design for FPS fuels and materials would be designing the test assemblies to operate at the very high temperatures, and matching as closely as possible the neutron energy spectra and the fuel energy density.



FIGURE 3-29 | DEVICE ASSEMBLY FACILITY AT NNSS

To support irradiation of fuel, several options are available. A test reactor, such as INL Advanced Test Reactor, could be used to achieve the appropriate burn-up, using high thermal neutron fluxes and very short test times (on the order of days or weeks). These tests would use pressure to achieve the desired test temperature. However, these tests would be limited given that the test reactor has a different neutron energy level than the proposed fast reactor concept. Another option is to use a university reactor at a lower flux with longer test times. This situation also has the same limitations as ATR, but has a flux closer to that desired for the reactor concept. The final option is to ground test and actual FPS. This test would mimic the actual conditions the fuel would experience in space. This test may even be the lowest cost option. More analysis would be necessary to come to a final preferred path.

Post Irradiation Examination would be done at a facility that has hot cells, such as INL, ORNL or PNNL. Samples could be tested using both destructive and non-destructive testing. The types of tests would look for fission product formation, migration, and retention, dimensional and density changes in the fuel (such as fuel swelling and creep), or other material property changes that could impact long-term fuel performance (such as fuel ductility).

4 | SAFETY, ENVIRONMENTAL PROTECTION, LAUNCH APPROVAL, AND SECURITY

A Safety Team, led by the EC Nuclear Safety Consultant and comprised of safety experts from DOE Headquarters and DOE's Sandia National Laboratories (SNL), National Environmental Policy Act (NEPA) experts from NASA's Jet Propulsion Laboratory (JPL), and a security expert from DOE's Idaho National Laboratory (INL), was established during the conduct of the NPAS. This Safety Team gathered and provided information, as needed, for the EC, the SST, and the MST throughout the conduct of the NPAS. In addition, the Safety Team offered inputs to the SST and MST to ensure that safety, environmental protection, launch approval, and security were appropriately considered in the DRSs and DRMs. While the primary emphasis of the NPAS was on planetary science missions, some top-level, cursory reviews of HEOMD needs were performed, clearly indicating that more study should be conducted in this area. Following is a summary of the important information and findings of the Safety Team.

4.1 | U.S. Space Nuclear Systems – The Safety Challenge

4.1.1 | Introduction

Nuclear systems have enabled tremendous strides in our country's exploration and use of space since 1961. The U.S. has launched 47 nuclear power systems and hundreds of radioisotope heater units (RHUs) in support of 31 missions that range from navigational, meteorological, communications, and experimental satellites to lunar, solar, Martian, Jovian, Saturnian, and outer solar system exploration missions. One mission (SNAPSHOT in 1965) involved a small 500 W_e reactor power system (SNAP-10A); the remaining missions were powered by RPS (specifically, RTGs); with many of the solar system exploration missions using RHUs [126–132].

The launch and use of space nuclear power systems presents unique safety challenges. These safety challenges, or issues, must be recognized and addressed in the design of each space nuclear power system, including consideration of potential accident conditions. In doing so, the planned and potential uses of each nuclear power system must be identified and characterized, in normal and off-normal operations, as well as in credible accident situations.²⁻⁴ Safety analyses and testing must then be conducted to determine the level of safety built into the nuclear system. Analyses must also be performed to establish the safety adequacy of the design for nuclear system ground testing. Other analyses are required to assess the potential environmental impacts and risks associated with the launch of any proposed U.S. space mission that would use space nuclear power; this includes quantitative assessments (both internal and external) that are provided to the White House Office of Science and Technology Policy (OSTP), so that an informed decision can be made at the highest levels of the Government about whether to proceed with launch, based upon risk-benefit considerations [127–129].

Effective safety engineering in the design, development, and use of nuclear technology is vital to the viability, acceptance, and continued use of nuclear energy systems in space. The public, employees, astronauts for crewed missions, the environment, property, and other resources must be protected. Past history has shown that this can be accomplished if appropriate safety objectives are established and met, using proven safety strategies and practices [127].

4.1.2 | Background History

A focus on safety from the outset, followed by meticulous continued attention to safety in design, development, and preparation for use, has permitted the U.S. to launch a variety of nuclear systems in support of civilian and military space missions [126–129]. Table 4-1 below lists all U.S. space nuclear systems launched to date.

TABLE 4-1 | SPACE NUCLEAR SYSTEMS LAUNCHED BY THE U.S. (1961-2014)

Mission	Mission Type	Launch Date	Nuclear Source (# sources/Nominal Output)	Status
TRANSIT 4A	Navigational	Jun 61	SNAP-3B7 (1/2.7 W _e)	Successfully achieved orbit; ops terminated 1966
TRANSIT 4B	Navigational	Nov 61	SNAP-3B8 (1/2.7 W _e)	Successfully achieved orbit; ops terminated 1967
TRANSIT 5BN-1	Navigational	Sep 63	SNAP-9A (1/25 W _e)	Successfully achieved orbit; ops terminated 1970
TRANSIT 5BN-2	Navigational	Dec 63	SNAP-9A (1/25 W _e)	Successfully achieved orbit; ops terminated 1971
TRANSIT 5BN-3	Navigational	Apr 64	SNAP-9A (1/25 W _e)	Failed to achieve orbit; SNAP-9A burned up on reentry as then designed/intended
SNAPSHOT	Experimental	Apr 65	SNAP-10A (1/500 W _e)	Successfully achieved orbit; S/C voltage regulator failed after 43 days; SNAP-10A reactor shutdown permanently in 3000+ year orbit
NIMBUS B-1	Meteorological	May 68	SNAP-19B2 (2/40 W _e each)	Vehicle destroyed during launch; SNAP-19B2s retrieved intact; fuel used on later mission
NIMBUS III	Meteorological	Apr 69	SNAP-19B3 (2/40 W _e each)	Successfully achieved orbit; ops terminated 1979
APOLLO 11	Lunar exploration	Jul 69	RHU (2/15 W _{th} each)	Successfully placed on moon, served to provide heat for the solar-powered Early Apollo Science Experiment Package (EASEP) batteries; ops terminated 1969
APOLLO 12	Lunar exploration	Nov 69	SNAP-27 (1/70 W _e)	Successfully placed on moon; ops terminated 1977
APOLLO 13	Lunar exploration	Apr 70	SNAP-27 (1/70 W _e)	Mission aborted en route to moon; SNAP-27 survived reentry & in 7000+ ft of water in deep ocean
APOLLO 14	Lunar exploration	Jan 71	SNAP-27 (1/70 W _e)	Successfully placed on moon; ops terminated 1977
APOLLO 15	Lunar exploration	Jul 71	SNAP-27 (1/70 W _e)	Successfully placed on moon; ops terminated 1977
PIONEER 10	Solar system exploration	Mar 72	SNAP-19 (4/40 W _e each) RHU (12/1 W _{th} each)	Successfully placed on interplanetary trajectory; ops terminated 2003
APOLLO 16	Lunar exploration	Mar 72	SNAP-27 (1/70 W _e)	Successfully placed on moon; ops terminated 1977
TRIAD-01-1X	Navigational	Sep 72	TRANSIT-RTG (1/30 W _e)	Successfully achieved orbit; ops terminated 1977
APOLLO 17	Lunar exploration	Dec 72	SNAP-27 (1/70 W _e)	Successfully placed on moon; ops terminated 1977
PIONEER 11	Solar system exploration	Apr 73	SNAP-19 (4/40 W _e each) RHU (12/1 W _{th} each)	Successfully placed on interplanetary trajectory; ops terminated 1995
VIKING 1	Mars exploration	Aug 75	SNAP-19 (2/40 W _e each)	Successfully placed on Mars; ops terminated 1982
VIKING 2	Mars exploration	Sep 75	SNAP-19 (2/40 W _e each)	Successfully placed on Mars; ops terminated 1982
LES 8	Communications	Mar 76	MHW-RTG (2/150 W _e each)	Successfully achieved orbit for ops
LES 9	Communications	Mar 76	MHW-RTG (2/150 W _e each)	Successfully achieved orbit for ops
VOYAGER 2	Solar system exploration	Aug 77	MHW-RTG (3/150 W _e each) RHU (9/1 W _{th} each)	Successfully placed on interplanetary trajectory; still operational
VOYAGER 1	Solar system exploration	Sep 77	MHW-RTG (3/150 W _e each) RHU (9/1 W _{th} each)	Successfully placed on interplanetary trajectory; still operational
GALILEO	Jovian exploration	Oct 89	GPHS-RTG (2/275 W _e each) LWRHU (120/1 W _{th} each)	Successfully placed in orbit around Jupiter; deorbited into atmosphere of Jupiter following end-of-mission
ULYSSES	Solar polar exploration	Oct 90	GPHS-RTG (1/275 W _e)	Successfully placed in orbit around Sun; ops terminated 2009
MARS PATHFINDER	Mars rover exploration	Dec 96	LWRHU (3/1 W _{th} each)	Successfully placed on Mars; rover ceased ops in 1997
CASSINI	Saturnian exploration	Oct 97	GPHS-RTG (3/275 W _e each) LWRHU (117/1 W _{th} each)	Successfully placed in orbit around Saturn; still operational
MER-A (Spirit)	Mars rover exploration	Jun 03	LWRHU (8/1 W _{th} each)	Successfully placed on Mars; ops ended 2010
MER-B (Opportunity)	Mars rover exploration	Jul 03	LWRHU (8/1 W _{th} each)	Successfully placed on Mars; still operational
NEW HORIZONS	Pluto/Kuiper Belt Exploration	Jan 06	GPHS-RTG (1/245 W _e)	En-route to Pluto w/arrival in 2015
MSL (Curiosity)	Mars rover exploration	Nov 11	MMRTG (1/110 W _e)	Successfully placed on Mars; still operational

The most recent launches of U.S. nuclear-powered space missions occurred in January 2006, with the launch of the Pluto–New Horizons (PNH) spacecraft, which will study Pluto and its moons in 2015, and then fly onward to the Kuiper Belt and beyond; and in November 2011, with the launch of the Mars Science Laboratory (MSL) spacecraft and Curiosity rover, which is now exploring and characterizing Gale Crater on Mars. As with previous missions, PNH and MSL/Curiosity were extensively reviewed from a system-safety and mission-risk perspective prior to launch [127].

Launch and space flight involve risk of failures or accidents. Some failures can pose severe accident environments to an on-board nuclear heat source or system. In general, the most critical periods include launch, ascent, and orbital or trajectory insertion, when large quantities of propellant are present. Accident environments in these mission phases can include blast overpressure, impacts from small shrapnel and larger fragments, Earth-surface impact, debris impact, propellant fires, and atmospheric reentry heating and ablation. Overall, the probability of a catastrophic launch vehicle/upper stage accident is in the range of a few percent (~1-4%), based on historical data [127].

Three accidents involving U.S. space nuclear power systems have occurred; all three involved the launch vehicle or transfer stage, and were unrelated to the power system. In each case, the nuclear systems responded as designed and there were no hazardous consequences. A chronological summary of these failures follows [127].

The first failure occurred on April 21, 1964, when the Transit 5BN-3 navigational satellite failed to achieve Earth orbit after a computer malfunction prematurely shut down an upper stage booster. The satellite and its 25-W_e SNAP-9A RTG power system reentered the Earth's atmosphere and burned up completely, as early RTGs were designed to do [132], at an altitude of ~50 km. Approximately 20,000 Curies of plutonium-238 were released into the upper atmosphere and dispersed worldwide. Subsequently, the design criteria for RTGs under accidental reentry was changed from complete breakup, burn up, and dispersal at high altitude, to intact survival, that is, with fuel containment and confinement preserved through reentry [127,132–135].

On May 18, 1968, the launch of the Nimbus B-1 meteorological satellite from Vandenberg Air Force Base, California, with two 40-W_e SNAP-19B2 RTGs aboard, was terminated by the Range Safety Officer about one minute into flight due to an erratically ascending launch vehicle, to protect the public and property on the ground in the area. Although the launch vehicle and satellite were completely destroyed, the RTGs survived intact with no release of radioactive fuel. Both SNAP-19B2 RTGs were retrieved from the Santa Barbara channel. The fuel recovered from these RTGs was used on a subsequent mission [126,127].

Lastly, in April 1970, the Apollo 13 mission was aborted on the way to the Moon because of an explosion of an oxygen tank in the service module. A 70-W_e SNAP-27 RTG was on the lunar lander to power an Apollo Lunar Surface Experiment Package (ALSEP), with the insertable fuel canister and thermoelectric generator housing stored separately. Because the lunar lander returned to Earth after serving as a crew “life boat,” it and the SNAP-27 RTG fuel canister experienced atmospheric reentry. The SNAP-27 RTG fuel canister survived reentry intact, with no detected release of radioactive material, and sank to a depth in excess of 2135 meters at the bottom of the South Pacific Ocean in the vicinity of the Tonga trench, where it remains [127].

Although failures have occurred, they were anticipated by prior analyses and specifically accounted for in the design of the on-board nuclear systems, thus preventing hazardous radiological consequences. Moreover, it should be noted that for the above mission failures, radiological measurements and evaluations were conducted to permit recovery from and final determination of each accident. In summary, the historical record indicates that the U.S. space nuclear safety program has worked extremely well [127].

4.1.3 | The Foundations of U.S. Space Nuclear Power Safety

Sections 4.1.3.1 and 4.1.3.2 convey the current approach to safety for U.S. space nuclear power systems and missions. This approach has been developed over time based upon the early, pioneering efforts under the SNAP Program [130–132], as well as all subsequent RPS and FPS development and flight programs [1,136–142]. Although national needs, requirements, and protocols have changed over time, and our technical insight of safety and security issues have progressed, safety has always been emphasized from the very beginning [8,127,132].

4.1.3.1 | Purpose, Objectives & Strategy of Safety

Safety is an integral part of any nuclear system, and it encompasses the entire system lifecycle. Its purpose is protection of the public, the environment, workers, property, and other resources from undue risk of injury or harm. In support of this purpose, three objectives must be met: 1) Create a safe product; 2) Demonstrate safety – convincingly; and 3) Obtain the necessary approvals for development, ground test, launch and mission use [127]. The strategy used to meet these objectives for any U.S. space nuclear heat source or system is to: 1) Design and build safety into each nuclear heat source and system at the outset, considering its potential applications; 2) Demonstrate the safety of each nuclear heat source and system through rigorous analysis and testing; and 3) Separately and quantitatively assess the environmental impact as well as the level of risk for each proposed nuclear system and nuclear-powered space mission, in support of the National Environmental Policy Act (NEPA) of 1969 and Presidential Directive/National Security Council Memorandum – 25 (PD/NSC-25) of 1977, as amended [1,127,143,144]. In addition, in recognition of the real possibility of failure or accident during launch, radiological contingency planning is conducted in preparation for each launch of a nuclear heat source or power system. That contingency planning involves, among other things, personnel training, equipment checkout, and instrument calibration and checkout, as well as exercises of the plan prior to launch.

Section 4.1.3.2 addresses the first step, i.e., design and build safety into each nuclear heat source and system at the outset, considering its potential applications, while Section 4.2 addresses the second and third steps.

4.1.3.2 | Building Safety into the Design of U.S. Space Nuclear Systems

Before the design of a U.S. space nuclear system can proceed in earnest, clear safety criteria must be in place to guide designers and mission planners [127]. Such top-level safety criteria should be functional in nature, as opposed to prescriptive, so that designers and mission planners are afforded maximum flexibility to consider a wide spectrum of options regarding how the criteria are met. These safety criteria will be different for RPS and FPS, primarily because the safety issues associated with RPS vary from those for FPS [127]. For example, the primary issue associated with RPS is possible release of the radioactive fuel into the environment or biosphere; this leads to RPS designs that focus on fuel containment, confinement, and stability for all credible accidents that could occur during its life cycle [1,127]. The issues associated with FPS are more complex, and include, for example, the potential for inadvertent criticality, as a result of a launch or post-reentry Earth impact accident; core disruption during operation in space, due to overpower or undercooling situations; and, release of reactor fuel and any fission or activation products as a result of an accident during its life cycle [127,145–147]. Also, the issues and safety criteria will be different for robotic and crewed missions, particularly for crewed Mars surface missions that would have human presence nearby either during surface operations or afterwards in the future.

RPS safety issues are very well understood; sound, fully vetted, and approved safety criteria are in place for RPS [1,127]. The same level of historic fidelity for FPS safety criteria does not yet exist, although FPS safety issues are understood [127,145–147]. Such safety criteria are termed herein “Functional Design and Operational Safety Criteria,” to ensure that FPS safety criteria, when developed and put in place, are functional in nature and address operational situations that could occur during the FPS life cycle. It should be noted that although FPS safety policy and criteria have in the past been addressed for in-space nuclear

propulsion [140], crewed space missions involving FPS surface operations with human presence nearby, have not been studied to the extent that deep space and robotic missions have, and are likely to be more demanding.

If and when the U.S. decides to consider pursuing FPS technology in earnest, it is imperative that sound *Functional Design & Operational Safety Criteria* be put in place before concerted FPS design efforts proceed.

Such *Functional Design and Operational Safety Criteria* for FPS would be developed by experts with the involvement of all stakeholder Agencies, and subsequently should be approved by all decision makers, e.g., stakeholder Agency heads and the Director of the Office of Science and Technology Policy.

Any space nuclear power system development program must include a vibrant safety program from the outset.

Such a safety program would incorporate not only attributes identified herein but would establish: 1) A set of risk-based safety requirements (derived from top-level safety policy, objectives, strategy, as well as *Functional Design and Operational Safety Criteria*, which are integrated into the design process at an early stage and carried through to realization and operation of the system); 2) Clear lines of authority, responsibility, and communications; 3) Feedback mechanisms (for continual monitoring and evaluation); and, 4) Independent safety oversight [127–129,140,142,147]. Moreover, to build a “safety culture” within the development program, management at all levels should foster a safety consciousness among all program participants and throughout all aspects of the space nuclear system development program [127–129,140,142,147].

4.2 | Assessing the Environmental Impact, Safety, & Risk Associated with the Development & Use of Space Nuclear Systems

This section addresses the second and third steps required to meet the safety objectives and purpose stated in Section 4.1. Specifically, Section 4.2.1, addresses environmental compliance under NEPA; and Section 4.2.2, addresses safety analyses and evaluations established under PD/NSC-25 of 1977, as amended. These two processes are separate and distinct; hence, their separate treatment.

4.2.1 | NEPA Compliance Process

NEPA requires all Federal agency decision-makers to consider the potential environmental impacts of proposed actions before committing to a specific course of action. In doing so, NEPA directs agencies to consider alternatives to their proposed activities. In essence, NEPA requires NASA decision makers to integrate the NEPA process into early planning to ensure appropriate consideration of environmental factors, along with technical and economic ones. NEPA is also an environmental disclosure statute, in that it requires that the best available information about the proposed action be made available to the public before a decision to proceed is made, as well as to relevant Federal, state, and local agencies. NEPA does not require that the proposed action or activity must be the most environmentally benign of potential alternatives. NEPA only requires that a decision-maker consider (and fully disclose) environmental impacts as one factor before deciding to implement an action.

NASA Procedural Requirements (NPR) 8580.1A describes NASA's requirements for implementing NEPA, and NASA's overall environmental planning process. It requires compliance with NASA and Council on Environmental Quality (CEQ) regulations, specifically 14 Code of Federal Regulations (CFR) Part 1216 and 40 CFR Parts 1500-1508 [148]. NPR 8580.1A describes what type of NEPA documentation must be completed: a Categorical Exclusion (CatEx) document, an Environmental Assessment (EA), or an Environmental Impact Statement (EIS), plus their associated decision documents.

All NASA missions need some type of NEPA documentation. Adopting existing environmental documentation is allowed and encouraged. NEPA compliance documentation must be completed before project planning reaches a point where NASA's ability to implement reasonable alternatives is effectively precluded, i.e., before major decisions are made regarding project implementation. Environmental planning factors should be integrated into the Pre-Phase A concept study when a broad range of alternatives are being considered.

At a minimum, an environmental evaluation should be initiated in the Phase A concept development stage. During this stage, the responsible project manager will have the greatest latitude in making adjustments in the plan to mitigate or avoid important environmental impacts, and in planning the balance of the NEPA process to avoid future unexpected events that may have schedule or cost implications. Before completing the NEPA process, no NASA official should take an action that would limit the choice of reasonable alternatives. Accommodating environmental requirements early in project planning ultimately conserves both budget and schedule flexibility.

4.2.1.1 | Specific NEPA Considerations for any Potential Future FPS Development

The major difference in NEPA compliance between a space reactor development versus the mission specific launch of an RPS-powered mission would be the potential need for developing programmatic-level NEPA documentation for FPS in advance of any mission-specific NEPA documentation. Such programmatic-level documentation for current RPS (e.g., ASRG, MMRTG) has been developed. Regulations from CEQ allow programmatic NEPA review of new agency programs with connected actions. Programmatic NEPA review avoids the possible segmenting (the breaking of a Federal project into a number of smaller actions) of environmental analyses by analyzing an entire program or suite of related or similar actions, e.g., the combined air quality impacts of rocket motor exhaust, evaluated across the entire array of related missions. For example, developing a space reactor may not be the only NASA action that would be required in order to launch a space reactor. NASA may need to make alterations to facilities or build new facilities to integrate a space reactor with a payload or launch vehicle. DOE may need to make alterations or build new facilities in developing and testing a space reactor. Since these actions would likely take place in a variety of geographical locations, at different times, i.e., over the course of 5-10 years), it would not be possible to sufficiently address all the environmental factors in one NEPA document. A programmatic approach, creating a combination of NEPA documents (including adopting existing relevant NEPA documents), over a period of time, leading ultimately to a mission-specific NEPA document would be necessary. An example of a notional programmatic NEPA approach and schedule for a space reactor development is provided in Figure 4-1.

The schedule line for the mission-specific NEPA document shown in the figure would be representative of the EIS schedule for a RPS mission.

The Programmatic EIS would need to be completed early in such a program, and would need to address NASA's purpose and need for developing a space reactor. This EIS would need to address a range of reasonable alternatives to this proposed action (including a "No Action" alternative) and evaluate associated environmental impacts. The document would generally describe possible future related environmental documentation to address impacts in various geographical locations and varying times. This first Programmatic EIS would need to be completed in advance of any related NEPA documentation for proposed facilities or missions, and would be based on the best available information. It is estimated that this Programmatic EIS would take about two years to complete.

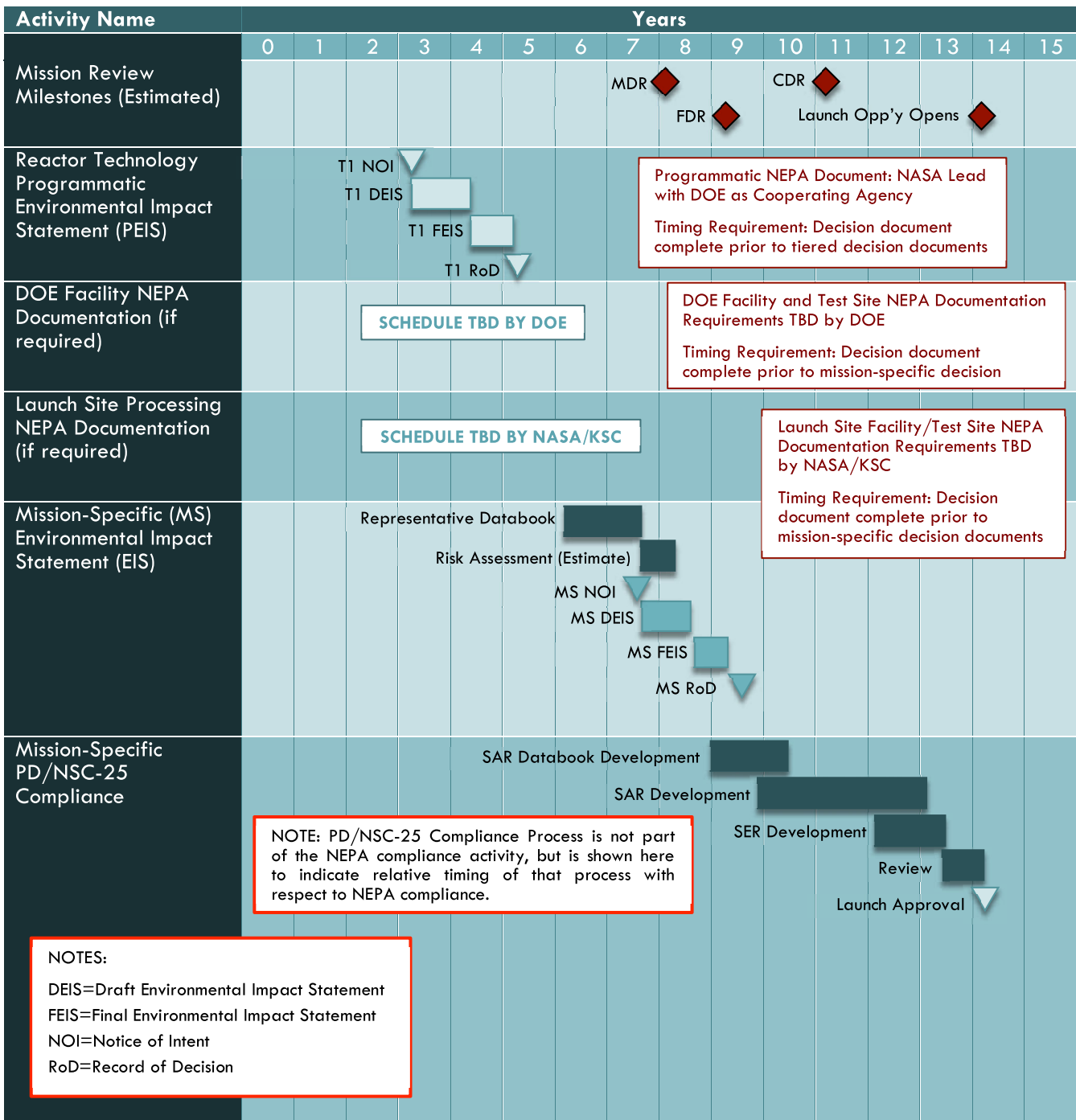

FIGURE 4-1 | NOTIONAL PROGRAMMATIC NEPA APPROACH

Regarding DOE facilities, it is possible that existing DOE NEPA documentation may be adequate to support the proposed NASA action. However, given the many uncertainties that exist, additional DOE NEPA documentation could be required and should be planned for accordingly. NASA would need to formally adopt existing DOE NEPA documentation relevant to the development of a space reactor. Additionally, depending on the timing of actions and availability of DOE resources, new or modified NEPA documentation could be required.

If NASA needed to develop a new Assembly Test and Launch Operations (ATLO) facility or substantially alter an existing one, it may be necessary to develop an EA or EIS for that proposed action. The time required for such NEPA documentation could range from about nine months to two years.

For mission-specific NEPA documentation, such follow-on documents would likely require two years to complete. However, it may be prudent to build in more time in the development schedule for the first launch of a new space reactor. Public interest would likely be large, and it is possible that opposition could be substantial. Additional time would allow NASA to reach out to launch area communities prior to formally initiating the NEPA process to hear their environmental input and concerns. This would help NASA better address any concerns in the draft EIS and perhaps reduce the overall level of public concern during the development of the final EIS and beyond.

4.2.2 | US Safety Analysis, Review, and Launch Approval Process

4.2.2.1 | The Launch Approval Process

NPR 8715.3, Chapter 6 describes the procedural requirements for characterizing and reporting potential risks associated with a planned launch of radioactive materials into space, on launch vehicles and spacecraft, during normal or abnormal flight conditions. Procedures and levels of review and analysis required for launch nuclear safety approval vary with the quantity of radioactive material planned for use and potential risk to the general public and the environment [149]. Launches involving the use of small quantities of radiological material for science instrumentation usually only require reporting or assessment, review and approval within NASA.

However, for any U.S. space mission involving the use of RPS, radioisotope heating units, nuclear reactors, or a major nuclear source, launch approval must be obtained from the Office of the President [144]. The approval decision is based on an established, and proven, review process that includes an independent evaluation by an *ad hoc* Interagency Nuclear Safety Review Panel (INSRP) comprised of representatives from NASA, the Department of Energy (DOE), the Department of Defense (DoD), and the Environmental Protection Agency (EPA), with an additional technical advisor from the Nuclear Regulatory Commission (NRC) [144].

The Presidential launch nuclear safety approval process requirement for a detailed safety analysis of the actual system (i.e. power source, spacecraft, launch vehicle, mission design) built for launch, results in a more highly developed model of the NPS application [150]. This model provides a tool that affords greater insight into the elements of the application that influence the application's nuclear risk and provides information that guides the development of site-specific radiological contingency plans. Moreover, since the Presidential launch nuclear safety approval process involves all the federal government agencies that have a substantive safety responsibility for various aspects of the mission (i.e. NASA — spacecraft/mission safety; Department of Energy — NPS safety; Department of Defense — launch site and range safety; and Environmental Protection Agency — air, water, and accident cleanup safety), the development and evaluation of the safety analysis provides a focal point for coordinating interagency resolution of any nuclear safety issues identified during the development phase of the application [150].

The process of flow, shown in Figure 4-1, begins with development of a launch vehicle databook: a compendium of information describing the mission, launch complex, launch system, spacecraft, and nuclear system(s), along with potential accident scenarios including their associated environments and probabilities.

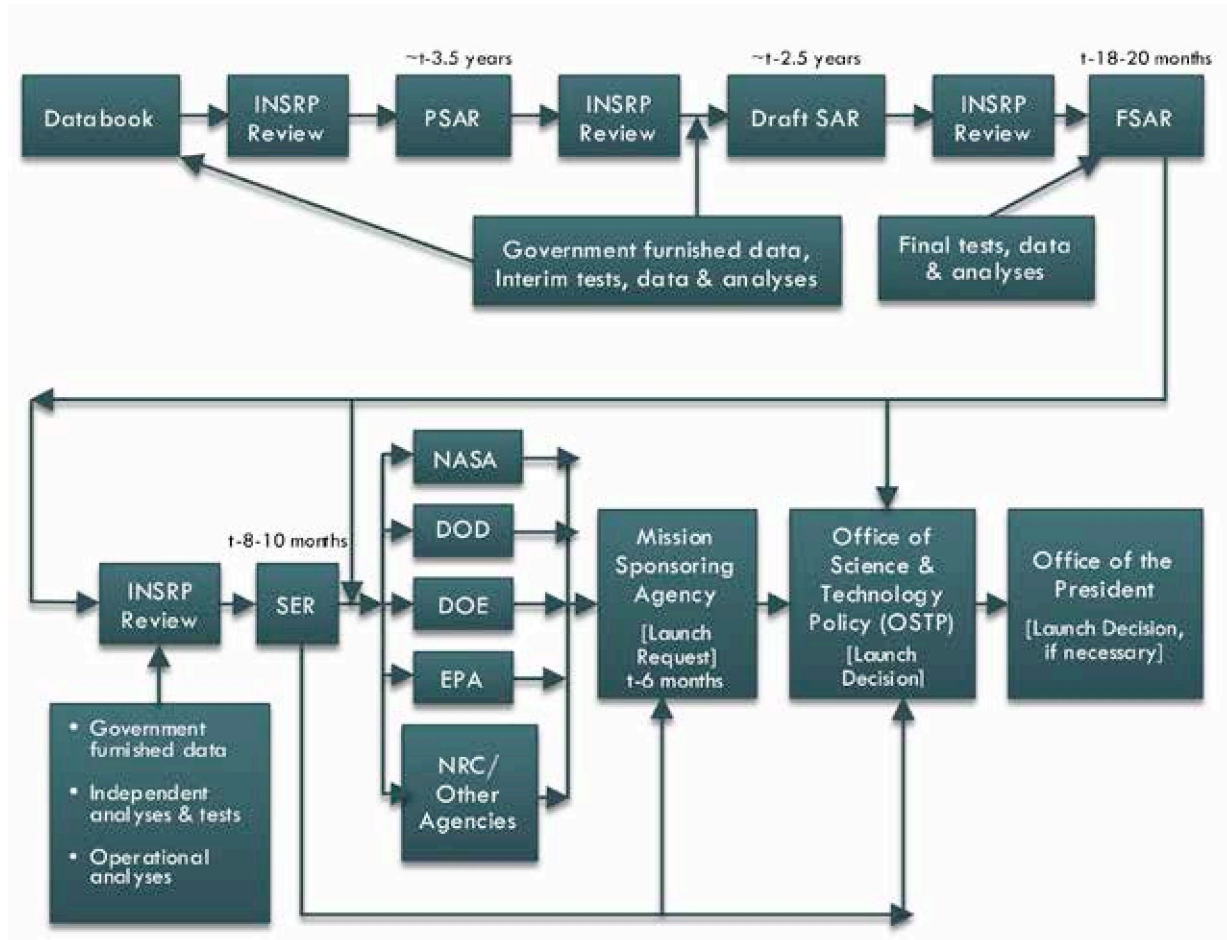

FIGURE 4-1 | THE U.S. SAFETY REVIEW & LAUNCH APPROVAL PROCESS FOR NUCLEAR-POWERED SPACE MISSIONS

DOE uses the databook to prepare a Preliminary Safety Analysis Report for the space mission. In all, three Safety Analysis Reports (SARs) are typically produced and submitted to the mission’s INSRP—the Preliminary SAR (PSAR), a Draft SAR (DSAR), and a Final SAR (FSAR). The DOE project office responsible for providing the nuclear power system (Office of Nuclear Energy, NE-75) develops these documents. The *ad hoc* INSRP conducts its nuclear safety/risk evaluation and documents their results in a nuclear Safety Evaluation Report (SER). The SER contains an independent evaluation of the mission radiological risk. DOE uses the SER as its basis for accepting the SAR.

If the DOE Secretary formally accepts the SAR-SER package, it is forwarded to the head of the mission-sponsoring agency, e.g., the NASA Administrator, Secretary of Defense, etc., for use in the launch-approval process. The mission-sponsoring agency distributes the SAR and SER to the other cognizant government agencies involved in the INSRP, and solicits their assessment of the documents. After receiving responses from these agencies, the agency conducts internal management reviews to address the SAR and SER, and any other nuclear safety information pertinent to the launch. If the agency recommends proceeding with the launch, then a formal request for nuclear safety launch approval is sent to the Director of the Office of Science and Technology Policy (OSTP) within the Office of the President; the SAR and SER are included with the request.

NASA Headquarters is responsible for implementing this process for NASA missions. DOE supports the process by analyzing the response of power system hardware to the different accident scenarios and environments identified in the databook and preparing a probabilistic risk assessment (PRA) of the potential radiological consequences and risks to the public and the environment for the mission. KSC is responsible for overseeing development of databooks, and traditionally uses JPL to characterize accident environments and integrate databooks. Both KSC and JPL subcontractors provide information relevant to supporting the development of databooks. The development team ultimately selected for a mission would be responsible for providing payload descriptions, describing how the nuclear hardware integrates into the spacecraft, describing the mission, and supporting KSC and JPL in their development of databooks.

4.2.2.2 | Elements of the Risk Assessment

The information provided in the sections below first appeared in Bechtel et al. [141], was presented to the United Nations, and outlines the steps required to conduct a safety analysis for a U.S. RPS-powered mission triggering PD/NSC-25.

An extensive safety-testing database is required for any use of nuclear hardware. This data is used as inputs into the safety analysis. The U.S. nuclear launch risk assessment for RPS is supported by over 30 years of safety tests of GPHS module hardware, ranging from component-level testing to full-scale RTG converter sections. The safety testing has focused on the response of a GPHS Fueled Clad (FC) to various insults. Typically, the FC response is reported in terms of clad gross distortion, crack dimensions (if any), and plutonium-dioxide released (if any), and the particle-size distribution of retained and any released fuel.

Following are examples of safety tests performed in support of the GPHS module and RPS hardware. Similar tests would need to be conducted for a FPS that uses a reactor as its heat source. FPS safety tests are not explicitly discussed below but would draw upon many of these tests. FPS are likely to require safety tests beyond those listed here.

Explosive-Overpressure Tests: Early testing featured shock-tube tests, also referred to as the explosive-overpressure tests. This test series evaluated the effects of a shock wave hitting either a GPHS module or RTG as the result of an explosion. The test module was oriented with one of the side surfaces normal to the direction of shockwave propagation. Simulant graphite blocks were placed on either side of it to simulate a stack of three modules. The FCs in the test module were filled with a uranium dioxide (UO₂) fuel simulant.

Fragment Projectile Tests: Fragment tests were conducted to determine the effects of small fragments and projectiles impinging on the GPHS module as a result of a launch vehicle (LV) explosion. Tests were initially conducted with aeroshell fine-weave pierced fabric (FWPF) material plates to determine the velocity attenuation afforded by the GPHS module aeroshell alone. These were followed by tests of half-module targets using aluminum bullets. In addition, this test series examined the impact of titanium bullets against bare FCs.

Drop Tests: Drop tests from a helicopter were conducted during the development of the GPHS module to determine the terminal velocity of the GPHS module and examine how it would tumble to the ground.

Solid Propellant Fire Tests: Two GPHS module components were exposed to an extended-duration fire from a large cube of solid propellant. These components, a bare FC and an impact assembly composed of a graphite impact shell (GIS) with two FCs, were placed on each side of the propellant block and directly exposed to the fire. A UO₂ fuel simulant was used in both components.

Bare Clad Impact Tests: The Bare Clad Impact (BCI) Tests were conducted to determine the FC and fuel response to impacts against different media, including steel, concrete, and sand, at different velocities. The test conditions were designed to reflect those that could result from an accident on-pad or during early ascent. BCI tests were conducted with FCs containing either UO₂ or plutonium dioxide.

General Purpose Heat Source Impact Tests: The GPHS module impact testing was designed to simulate the atmospheric reentry and subsequent Earth impact experienced by a GPHS module in the aftermath of an orbital abort. The GPHS module used in these tests were machined to remove a small layer of graphite from all exterior surfaces. This amount removed was based on twice the expected thickness of material ablated during an accidental reentry. All FCs within these GPHS modules were filled with plutonium dioxide fuel. The modules were subjected to a heat profile expected during reentry prior to being impacted at predicted post-reentry Earth impact velocities. The impact angle was varied in these tests. The modules were impacted against steel.

Large Fragment Tests: The Large Fragment Tests involved the impact of a large fragment from a launch vehicle casing against a simulated section of an RTG. A series of rocket-sled tests were conducted to simulate a large fragment impact. A simulated heat source was located inside the simulated RTG, and heated to pre-launch temperatures at time of impact. The simulated RTG consisted of a stack of eight GPHS modules, with two modules containing UO₂ simulant FCs and six modules made from bulk graphite, which contained solid molybdenum slugs representing FCs.

Flyer Plate Tests: The flyer plate tests involved the flat-on impact of a thin, plate-like fragment against a FC filled with UO₂ fuel simulant. The plate was composed of spacecraft-grade aluminum. The FCs used in the first three tests were remnants from one of the shock tube tests. The FCs were heated prior to testing, with the goal that they be at their pre-launch temperature.

Edge on Flyer Plate Tests: The Edge on Flyer Plate tests simulated the impact of large, plate-like fragments against fully loaded GPHS modules as well as bare FCs. All clads contained a UO₂ fuel simulant. The plates were accelerated to their target in an edge-on impact configuration using a sled track.

RTG End-On Impact Tests: The purpose of the RTG impact tests was to produce test data on FC distortion versus GPHS module stack position in the RTG and the variability in distortion at each position. A secondary objective was to obtain data on fractional fuel-simulant release in the event of a breach in a FC. A simulated RTG with a stack of nine simulated GPHS modules loaded with UO₂ FCs was heated to pre-launch temperatures. For this test a rocket sled propelled the simulated RTG into a concrete target.

Iridium Ductility Testing: The FCs used to encapsulate the plutonium dioxide fuel are made of an iridium alloy. To better understand the properties of this cladding material, tensile tests were performed at a variety of temperatures to characterize the response of the iridium alloy cladding material as a function temperature and strain rate.

Solid Propellant Fire Characterization Tests: A series of tests were conducted to investigate and characterize the environments underneath and near various types of solid propellants when burning in atmospheric conditions, and to measure the response of various isotopic materials or surrogates to those environments.

4.2.2.3 | Safety Analysis Computational Overview

The following description of the computational analysis is primarily for an RPS-powered mission, with some commentary provided if a FPS were to be involved.

The launch safety analysis is performed using a suite of computer codes to model various stages and phenomena of the accident sequence, radioisotope release (“source term”), radioisotope transport, and consequences. Figure 4-2 shows the computation flow for the launch-approval safety analysis. NASA develops a Databook for the launch vehicle and accident probabilities and environments. This serves as an input to the calculations. Phenomenological codes [151] determine the response of the RPS hardware to blast, impact, fires, and reentry. These codes produce a set of look-up tables which are used as an input to predict the source term for a given accident scenario. Typically the safety features of the RPS prevent a release of material. Should a release occur, the source term is transferred to a consequence suite of codes to determine how far any released material

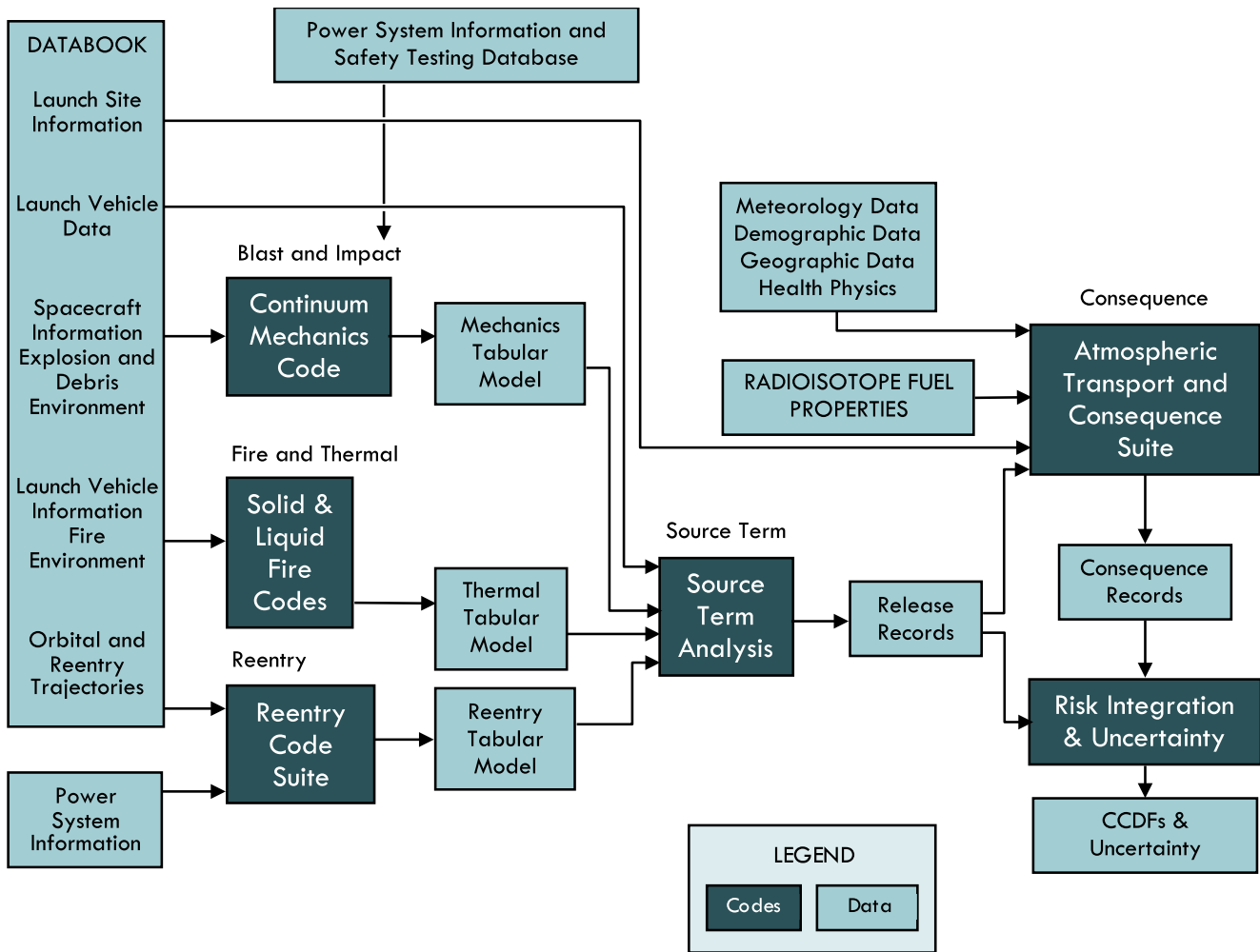

FIGURE 4-2 | COMPUTATIONAL FLOW FOR THE LAUNCH APPROVAL SAFETY ANALYSIS

might be transported and what health effects or environmental effects might result. The final product of the risk assessment is a distribution of probability of accident, probability of release, possible consequences, mean values, and an estimate of the risk.

The potential accident scenarios that can arise are more extensive than can be tested. Therefore, the safety analysis relies on numerical modeling to augment the existing safety-test database. The potentially damaging environments that must be modeled are the blast from the launch destruct event, the impact of the RPS hardware on the ground, and the impact of debris and solid propellant fragments onto the RPS hardware. Continuum mechanics codes are used to model explicitly the accident environments defined within the databook. These programs include nonlinear, constitutive models and accurately analyze large deformations that may lead to geometric nonlinearities. These numerical simulations of mechanical damage due to blast and impact conditions provide an estimate of the damage to the power source (and its components), particularly the damage to the FCs within the power source. Estimates of the FC exposure, breach, and deformation are determined from the numerical simulations. The assessment is performed on a clad-by-clad basis for each accident case with the results being provided to a release model embedded in the source-term analysis code. The release model determines the quantity and particle size distribution of the plutonium dioxide of any released material based on the clad damage information provided from the numerical simulations.

These numerical simulations examine mechanical loading conditions such as blast, ground impacts, impacts from spacecraft fragments, and for some missions, debris from an intact spacecraft. The mechanical damage in most cases is due to a complex chain of events. The numerical simulations decouple the complex chain of events and feed the source term analysis code information about individual events that can then be used to account for the progressive chain of events. The source-term analysis code is provided details on FC exposure, deformation, and breach within matrices of ground-impact events, fragment impacts, spacecraft-debris impact, and blast. These individual results can then be combined for an estimate of the resulting release due to mechanical loading.

A criticality safety analysis is conducted for all RPS missions. However for RPS missions, there is insufficient material to produce a critical reaction so this is not a focus of the safety assessment. It is conducted for completeness. For a mission with an FPS, the criticality analysis would be a significant element of the analysis. Continuum mechanics codes would be used to model the response of the FPS to impacts on the ground and by debris, and for overpressure waves at very small time steps. These results would be sent to a nuclear criticality code such as MCNP to determine the criticality and reactivity of the modified FPS for all time steps through the end of the mechanical insult.

The launch accident environment can have liquid propellant fires and solid propellant fires. The U.S. has built several layers of protection into its hardware to help prevent a release of RPS fuel in the event of a launch-area accident. For instance, liquid propellant fires are not expected to burn hot enough to melt the iridium clad containing the RPS fuel. Several codes [151] are used to model the liquid propellant fires, solid propellant fires, thermal-mechanical impacts and vaporization environments effects on the RPS hardware and fuel.

Inputs to the code characterize the solid propellant ground fire, the buoyant cloud, and the distribution of any released plutonium dioxide mass into bins of various particle sizes from a coincident or near-coincident impact. From this starting point, the code suite predicts the composition and particle-size distribution of aerosols containing plutonium dioxide in the buoyant cloud. In effect, the code transforms the source term (mass by size bin) of plutonium dioxide particles released by mechanical insult into one that includes the effects of vaporization, condensation, and particle agglomeration.

NPS-enabled spacecraft may be subject to inadvertent reentry scenarios. For RPS-enabled missions, the nuclear heat source (one or more GPHS modules) is designed to survive reentry conditions, and a suite of codes is used to evaluate and confirm the response of the modules. For FPS-enabled missions, the most recent preferred reentry responses of the reactor power system have been either: 1) breakup and complete burn-up of the reactor, reactor fuel, and any activated materials at high altitude; or 2) intact reentry of the reactor (containing its nuclear fuel) and any activated components until earth-surface impact [137,139,146]. Several codes are used together to provide an integrated solution to the sequential physics problems of motion, heating, thermal response, chemistry, and inviscid flowfields that may be encountered during reentry. Evaluation of the parametric reentry space requires performing thousands of solutions for the reentry flight dynamics, aerodynamic surface heating, and the ablation and thermal response of the nuclear heat source. This analysis is performed for each individual mission since each mission has unique orbital characteristics. The thermal, physical and velocity results of this analysis are passed on to the source term analysis.

The source term is the amount and form of the RPS fuel, if any, which may be released. Since the hardware is designed to contain the fuel, the source term may have a null value. The source term for the launch safety analysis is generated using a Monte Carlo code that generates millions of potential outcomes for a single mission analysis. It attempts to characterize all threatening elements of the launch-accident environment.

Each simulation starts with a determination of where the accident occurs by randomly sampling a probability distribution function from the launch vehicle. The source term code then steps through all the insults that would

occur in that accident: including the initial blast, in-air fragment impacts, ground impact of the RPS, impact of solid propellant or other large fragments on the RPS, rain of debris, and liquid and solid propellant fires. Various distributions are sampled throughout the simulation, resulting in millions of unique solutions.

The final result from source term analysis is a distribution of potential fuel releases for the consequence analysis to sample. Details on the final releases include mass released, particle size distribution, release location, and fire environment parameters. The results also define the probability of a release given an accident, which, combined with the accident probability, yields the total probability for the scenario.

The consequence suite is a set of codes that calculates the atmospheric transport of released RPS fuel and the subsequent consequences in terms of health effects, doses, and land contamination. Health effects are characterized as the number of latent cancer fatalities over the subsequent 50 years. The linear, no-threshold, dose model is used along with an option for a *de minimis* (threshold) value. The code suite is run stochastically for numerous scenarios, called “observations.” The specific source term, weather conditions, and time of launch are randomly selected for each observation. Importance sampling is used to ensure that combinations of variables that result in low-probability, high-consequence events are considered in the analysis.

Modeling of atmospheric transport is accomplished using a Lagrangian-trajectory, Gaussian model of the puff, with the capability to handle multiple particle-size source terms. The transport and diffusion of material in a cloud puff are governed by meteorological conditions that can vary in space and time. These conditions include wind components at grid points, stability class, height of mixing layer, and roughness of the surface below. Each source cloud, defined with characteristics such as particle size, initial cloud dimensions, and initial coordinates, is tracked in time steps through a four-dimensional wind field (three spatial dimensions plus time).

Where puff interaction with the ground would occur, the calculation of air and ground concentrations at defined grid points is initiated. Following the transport and concentration calculation, the potential doses and health effects to exposed population are evaluated. A separate module computes potential doses based on dose conversion factors (DCFs) for the different dose pathways. Since the source terms may involve various particle sizes and the resolution may change from one application to another, this built-in module does not restrict the DCF values to a fixed list of particle sizes. The dose and health-effects calculations also encompass other data related to potentially contaminated areas, such as population density, land usage, food production, and food consumption.

The results of the consequence suite are combined into tables of mean consequences, various percentile consequences, and risk (mean consequence times release probability). Complementary cumulative distribution function graphs are also created at various levels of confidence. These graphs show the probability that a particular level of consequence or greater might occur at each level of confidence. These results provide the technical basis for the decision maker to assess the risk introduced when conducting a space nuclear power application.

4.3 | Security for a Fission Power System

4.3.1 | Introduction

The Security Performance and Accountability Division at DOE's INL conducted a security gap analysis of a potential future project that would utilize Category I Special Nuclear Material (SNM) at the Kennedy Space Center (KSC) in support of an FPS for a future space mission.

Various options were evaluated in an attempt to identify the best approach to protecting Category I SNM when present at KSC in advance of a launch. Decision criteria used to identify protective system designs that could provide the most effective and cost-efficient protection effectiveness were:

- Degree of risk reduction
- Cost effectiveness
- Adherence to DOE Order Protection requirements [152,153]
- Sustainability
- Implementation practicality
- Safety, and
- Benefits to all stakeholders

The security gap analysis and findings identified by this study task were based on a number of different activities, which included on-site visits, facility walk downs and meetings with managers representing both KSC and Air Force contract security; the development of cost estimates for different security upgrade approaches; and, analysis to identify protection options and alternatives that would provide the greatest degree of risk reduction when considering cost effectiveness and DOE Order requirements [152–155].

4.3.2 | Security Summary²⁵

INL Battelle Energy Alliance (BEA) Safeguards and Security was tasked to conduct a security gap analysis by comparing existing security infrastructure and protection afforded to Category III SNM, e.g. Pu-238, at NASA KSC to DOE Order requirements for adequate protection of Category I SNM, if this more restricted category of nuclear material was physically present and utilized at KSC in the future for a space mission involving an FPS.

The operational concept that was analyzed consists of a nine-month security campaign repeated approximately once every three years, for the next 18 years. Each nine-month campaign would require the movement of Category I SNM to four different on-site locations at KSC. The first location, where Category I SNM is initially stored and utilized, would be the Radioisotope Thermoelectric Generator Facility (RTGF). Each FPS campaign would utilize the RTGF location for the longest duration in comparison to all other on-site facilities that would be involved (approximately 4.5 months, or half the total duration of each). While at the RTGF, the Category I SNM would be in its most transportable state in a building that provides the least delay to physical threat in comparison to all other on-site locations that would be utilized in the later stages of the project.

Based on both the length of time Category I SNM would be physically present at the RTGF and the size, portability, configuration, and weight of SNM, it was recognized that the lowest risk option would be the

²⁵ A detailed “official use only” report of the work described above has been generated by INL [160] and can be obtained by contacting Dr. Stephen G. Johnson at stephen.johnson@inl.gov or 208-533-7496.

construction of a new combined RPSF and FPS Facility, or RPSF/FPSF, including a new protected area that would meet DOE Order material access area (MAA) and protected area (PA) protection requirements. This approach, identified herein as “Option A,” meets DOE requirements and provides significantly more protective system effectiveness in comparison to other options evaluated. These options would involve retrofitting security upgrades to the existing RTGF, identified herein as options “B” and “C”. Although these options would be less expensive, there is significantly more risk in selecting either in comparison to “Option A.” In part, these risks include not meeting DOE Order MAA requirements and having potentially insufficient adversary barrier delay, which would require increased protective force staffing above and beyond what has been identified herein or increased risk to protection of the Category I SNM.

There are three other locations that would be utilized by the FPS campaign as Category I SNM is moved: the Payload Hazardous Storage Facility (PHSF), Vertical Integration Facility (VIF), and launch pad. The movement of Category I SNM as the project is relocated from one location to another would also be included in this category of protection. Unlike the protection methodology and approach used for the RTGF, these three project locations (and related movements between these locations) would incorporate manpower-intensive measures with a performance-based approach and a few selected security upgrades, as opposed to spending millions of dollars to meet DOE PA and MAA protection requirements at each. This protection approach is based on the shorter project duration phase at each of these facilities (usually lasting ~1 month or less), and the fact that the size, weight, portability, configuration, and accessibility of Category I SNM has inherent built-in security (for example, the Category I SNM would be located as high as ~150 feet above ground in the fairing of the Atlas V rocket, contained in a non-portable reactor).

Current protective force staffing levels at KSC do not allow any guard resources to protect Category I SNM, nor are current guards certified by DOE as Security Police Officer (SPO) IIs. Additionally, no SPO III offensive response capability as required by DOE Order exists on-site, nor is KSC capable of providing DOE-certified SPO III training. Based on these facts, the NPAS study found that DOE would need to assist NASA/KSC in conducting a SPO II selection and certification course. In order to obtain the needed SPO III personnel, it is recommended that DOE/NNSA provide SPO III volunteers who would be used on a three-month, rotating basis for each nine-month campaign. In addition to the SPO IIIs, it is also recommended that DOE/NNSA provide security staff members that have the expertise on a volunteer basis to meet specific DOE Category I SNM protection requirements for each campaign (e.g. Material Control and Accountability (MC&A), Vulnerability Assessment Analyst, etc.).

There were a number of advantages for all stakeholders using the above protective force approach, if DOE/NNSA sites would be given first priority to hiring SPO II qualified personnel from KSC after each nine-month campaign were completed. This would be considered a “cost avoidance” for DOE/NNSA, since there is always a need to hire and backfill vacant SPO II positions throughout the complex, and having a cadre of qualified SPO IIs would be viewed as advantageous. Additionally, this approach would provide incentives for individuals to become SPO II qualified, as opposed to having a nine-month job with no long-term job prospects.

There are some protection challenges for each campaign, regardless of the protection options that are selected. For example, DOE requires all DOE and NNSA sites to utilize the Argus alarm software operating system developed by the Lawrence Livermore National Laboratory [156]. Currently, KSC utilizes alarm-operating software from Lenel Co. [157], which would be cost prohibitive and not feasible to be replaced with an Argus operating system. Therefore, an equivalency or exemption would have to be approved by DOE.

In summary, the following rough cost estimates were completed:

- It would cost ~\$28 million to construct a new DOE-compliant PA and build a new RPSF/FPSF that meets DOE Order MAA protection requirements, to include installing a few security upgrades at the PHSF and VIF.
- It would cost ~\$42 million to select, train, and pay for labor for the nine-month FPS campaign that provides ~100 SPO IIs and ~16 SPO II first-line supervisors and includes SPO IIIs and security staff with DOE Category I SNM protection expertise from the DOE/NNSA complex.

The total cost estimate for a first nine-month FPS campaign that combines the two above physical security upgrades and protection labor cost estimates would be ~ \$70 million.

Every nine-month campaign thereafter equates to a rough cost estimate of ~\$40 million each, significantly less than the first campaign, since the one-time physical upgrades and some of the initial one-time equipment costs would be completed the first time.

4.4 | Summary of Schedule and Cost Impacts for New RPS

If a new RPS system is designed based upon the results of existing safety tests and analysis, then there would be only minor impacts to the cost and schedule associated with the safety analysis, review, and launch approval process required for a nuclear mission which would use the new RPS. For a new RPS design very similar to a previously flown RPS, e.g., the eMMRTG, there may be no need to start the launch-approval process sooner than normal. However, for a new RPS design significantly different from those previously flown, such as a SRG, it may be necessary to start the safety analysis, review, and launch-approval process at least one year sooner to familiarize participants involved in the process with the new design and any associated new or different issues that may be involved.

Costs are not expected to vary much from historical costs for NEPA, Launch Approval, or Security so long as adequate safety testing and analysis is performed during the design of the new RPS, and the databook is available. If the databook is not available, ~2-3 years would be required to develop and complete the databook before safety analysis supporting the launch-approval process could begin in earnest.

4.5 | Summary of Schedule and Cost Impacts for New FPS

4.5.1 | Schedule Impacts

For a new, first-of-its-kind FPS, it might be prudent to start the NEPA and launch-approval processes at least one year sooner than normal. Although the focus would be different, the schedule for safety analysis of an FPS-powered mission is not expected to vary from that typically involved for an RPS-powered mission. This schedule assumes that safety was properly and adequately factored into the design of the FPS from the onset of system design. All appropriate safety analyses (e.g., blast and impact, fires, reentry, and criticality studies) should have been completed and the design adjusted appropriately, prior to the beginning of the launch-approval process for a mission.

Development for first use and launch of a FPS would require Programmatic NEPA treatment, utilizing multiple documents to address activities at multiple locations. This NEPA Programmatic treatment would begin with a Tier 1 document to address the decision regarding FPS development, followed by multiple “tiered” documents to address the potential new RPSF/FPSF building at KSC and associated actions, and a mission-specific NEPA document when launch of an actual mission is proposed.

If and when NASA considers pursuing FPS development in earnest, NASA should initiate a programmatic NEPA strategy to encompass FPS development (including FPS testing); FPS flight-system production, transport, and checkout and testing; and, the construction and operation of a new RPSF/FPSF at the KSC/CCAFS. It is important to note that the option of building a new RPSF/FPSF to meet the requirements of Category I, Attractiveness B, HEU fuel for an FPS has been central to the findings from NPAS. If other options are pursued, the discussions are not as straightforward, since they would rely upon getting DOE concurrence for waivers to several current DOE regulations. This would involve accepting a certain amount of programmatic risk, which is not easily quantified in terms of either schedule or cost.

An example of a notional programmatic NEPA approach for FPS development is provided within a typical overall schedule illustrated in Figure 4-1 of Section 4.2.1.1. Each NEPA document would likely take 18 – 24 months to develop. The start and completion points for each of those documents would be dependent upon the details of the proposed approach and timeline for FPS development and use. It should also be noted that the launch-vehicle databook drives the mission-specific NEPA and launch-approval process schedules; if a databook is not available, it means that approximately 2-3 years must be added to the front end of the mission-specific NEPA schedule.

The existing RTGF would require significant security modifications to accommodate an FPS with Category I, HEU fuel, or a new RPSF/FPSF could be built. Even with significant security modifications, the existing RTGF would not meet all DOE requirements, and, therefore, several exemptions to DOE security requirements would have to be sought. There is no guarantee that these exemptions would be granted. A new facility could minimize risk, as all DOE regulations could be met with a new facility. Either option would require ~2-3 years for conceptual, preliminary, and final design reviews. It would be necessary to complete the NEPA process for the proposed facility prior to construction start, as part of a NEPA process.

A formal vulnerability analysis would be conducted as part of the design process to ensure that the prescribed security features would be sufficient for the design-basis threat [158]. Subsequent construction would require ~2 years, followed by ~six months to one year to complete required DOE nuclear operations and security readiness reviews. The new RPSF/FPSF should be completed ~1.5-2 years prior to the first FPS launch that it supports. Thus new RPSF/FPSF project should be initiated at roughly Launch-8 years.

It should be noted that the schedule for constructing a new RPSF/FPSF is based on new construction within DOE rules and regulations. If NASA's processes are slower or faster, the above stated schedules would have to be adjusted appropriately.

4.5.2 | Cost Impacts

Costs are not expected to vary much from historical costs for either NEPA or launch-approval processes, assuming that safety was adequately factored into the design of the FPS from the onset of system design. All appropriate safety analysis, e.g., blast and impact, and criticality studies, will have been completed and the design adjusted appropriately prior to the beginning of the launch-approval process for a mission. If not, the cost of the mission NEPA and launch approval activities would increase.

It should be noted that a programmatic EIS for FPS development would be needed as identified within the Schedule Impacts above; the estimated cost would be ~\$2-4 million.

5 | ROUGH ORDER-OF-MAGNITUDE (ROM) COSTS

5.1 | RPS Design, Development, Test and Engineering Assumptions

As part of this effort, the NPAS used best engineering judgments to assemble rough order-of-magnitude (ROM) costs for the development of flight systems using the notional Design Reference Systems (DRS)²⁶ described in Chapter 3. Here “flight system development” is taken to include Design, Development, Test and Engineering (DDT&E) of engineering units, qualification units and flight units. The RPS DDT&E costs were estimated using a bottoms-up approach and a base fiscal year of 2014. For the purposes of this study, the cost estimates were organized into three phases by a member of the System Study Team (SST) and defined as technology development, engineering development²⁷ and the balance of flight system development. Within each phase, the costs are derived based on the required design, analysis, hardware fabrication, and testing using best-guess engineering estimates by appropriate members of the SST. The DDT&E costs include NASA center support (JPL for TE, GRC for Stirling) for technology development and engineering development, as well as costs associated with an industry System Integration Contractor (SIC). The SIC is assumed to lead all system design, analysis, development, fabrication, and testing through delivery of the flight hardware to other DOE team members for fueling. The DOE costs for SIC contract management, fueling, assembly, test, delivery, and launch operations are included in the mission costs (Section 5.5). All DDT&E cost estimates included 30% estimate contingency²⁸

5.1.1 | Modular Advanced Radioisotope Thermoelectric Generator Development

For the ARTG DRS, costs were provided by JPL with input from Aerojet Rocketdyne based on the notional development plan shown in Figure 5-1. Engineering and flight system development phases would start in 2019 following completion of the SKD Technology Maturation Project. The five-year ARTG technology maturation builds upon the eMMRTG and includes both couple and module development that would lead to extended life testing. The RPS convertor development could be performed in parallel with the FPS convertor development, if required, but any differences in requirements would tend to preclude potential cost savings. The main differences between the RPS and FPS configurations are the mechanical attachment method, which is cantilevered for RPS and spring-loaded for FPS; the TE leg geometry, which is narrower for RPS; and the required operating temperatures, which are 1,275K for RPS and 1,050K for FPS. The five-year ARTG engineering development phase would include an unfueled two-GPHS-module “building block” qualification unit followed by an electrically heated qualification unit of the flight-like 16-GPHS-module generator (but no qualification unit fueled with Pu-238). The two-year flight system development phase would produce one 16-GPHS-module flight generator by 2030 that would provide ~350W_e EOM power. This is based on the assumption that sufficient new plutonium dioxide fuel would be produced at a 1.5 kg/year production rate. The 16-GPHS ARTG is the basis for the ARTG DRS cost estimate; however the estimate should be representative of ARTG systems with 8 to 18 GPHS modules.²⁹

²⁶ “Design Reference System” refers to notional power system concepts analyzed and costed in the process of assembling this report.

²⁷ An Engineering Model for these purposes is defined as a prototype with characteristic form, fit, and function used to discover and correct design deficiencies prior to finalizing the flight system design and embarking upon its construction. Engineering model development is a key phase of overall flight system development, but costed separately in this study.

²⁸ “Estimate contingency” is used rather than “margin” and/or “reserve” as these are set against a baseline, which does not exist.

²⁹ This cost relationship does not apply to the MST costs for different size notional ARTG systems as certain cost aspects are fixed regardless of size (transportation, ATLO, etc.) and others vary (heat source).

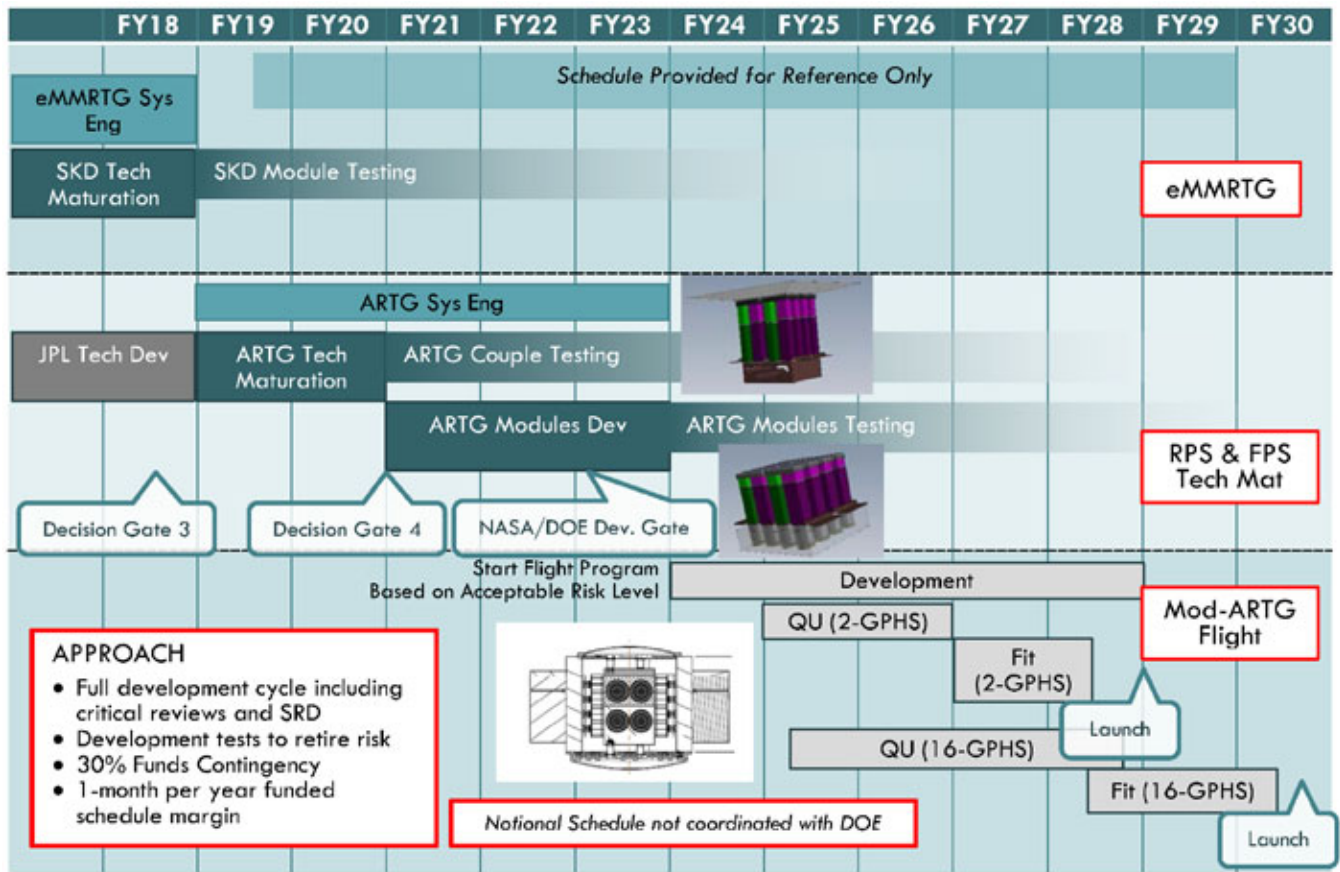

FIGURE 5-1 | 16-GPHS ARTG NOTIONAL DEVELOPMENT SCHEDULE

5.1.2 | Stirling Development

The SRG cost estimate was provided by GRC assuming extensive technical heritage from the ASRG development effort and referencing historical budget profiles from Lockheed Martin and Sunpower for similar systems. The notional SRG development schedule (Figure 5-2) shows two options. The primary option is the 6-GPHS SRG that would initiate in 2016 and conclude in the mid-2020s when new plutonium dioxide is available to fuel the first generator. The new SRG would leverage the prior component technologies and hardware assets from the ASRG project to the extent possible. The three-year technology development phase would include fast prototype,³⁰ easily inspected convertors and open-frame controllers that could be modified and rebuilt as the design evolves for the notional, new 6-GPHS SRG. The four-year engineering development phase would emphasize flight-like components assembled into prototype systems that would be tested in relevant environments to verify achievement of flight requirements. The overall development would include a sufficient number of convertors and controllers to establish a viable reliability database for flight. The engineering development phase would culminate in an integrated engineering model (EM) generator performance verification test followed by an extended duration (years) EM generator life test. The three-year flight system development phase assumes the use of an electrically-heated, 6-GPHS SRG qualification unit and an equivalent flight unit.³¹ This notional 6-GPHS SRG (300 W_e EOM) is the basis for the SRG DRS cost estimate, although it is believed to be representative of systems using from 3 to 8 GPHS modules.

³⁰ Fast prototype is an early, re-configurable, pre-final design unit that helps to inform the final design.

³¹ The need for a fueled qualification unit to qualify the generator fueling process would need to be further studied.

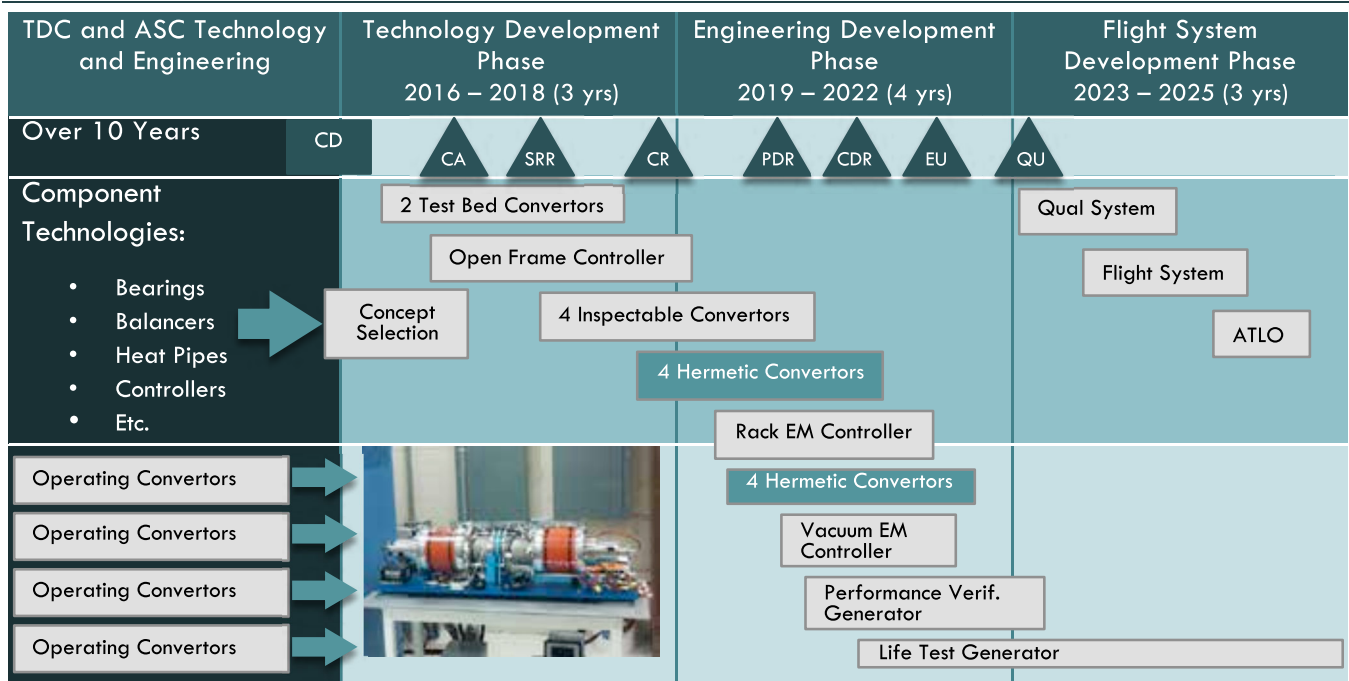

FIGURE 5-2 | 6-GPHS SRG NOTIONAL DEVELOPMENT SCHEDULES

An additional potential option is for a possible technology demonstration mission using available ASRG hardware assets to the extent possible. The concept would be to relax the original ASRG flight requirements to allow for a technology demonstration using non-flight-rated components based heavily on the current Engineering Unit #2 system under test at GRC. The “technology demo” mission, potentially funded by NASA STMD, could allow for the ASRG to operate as a non-mission critical system, with two GPHS-mockup electrical heat sources. The benefit of the “technology demo” mission is the ability to field a Stirling power flight system and address concerns on the readiness of Stirling technology for flight use. This concept requires further study to determine the feasibility and mission implementation approach and is not included in the SRG cost estimate.³²

5.2 | Fission Power System Design, Development, Test and Engineering Key Assumptions

The FPS DDT&E costs were estimated in a similar fashion to the RPS using a bottoms-up approach in fiscal year 2014 base year dollars. As with the RPS estimates, for the purposes of this study the FPS cost estimates were organized into three phases: technology development, engineering development, and the balance of flight system development. Within each phase, the costs were derived based on the required design, analysis, hardware fabrication, and testing using best-guess engineering estimates provided by members of the SST. The DDT&E costs include NASA center support (JPL for TE and GRC for Stirling), for technology development and engineering development as well as the costs associated with a SIC. The SIC is assumed to lead all system design, analysis, development, fabrication, and testing through delivery of the flight hardware to DOE for fueling. The Stirling FPS would utilize either ASRG-derivative convertors and controllers for the 1-kW_e system or P2A-derived convertors and an evolved ASRG controller for the 10-kW_e system. The 1-kW_e TE FPS would utilize ARTG-derived, spring-loaded SKD/LaTe/Zintl TE modules. Hardware deliverables provided by the SIC would include two EM units, one unfueled qualification unit (integrated with the control system), and one flight unit. The FPS DDT&E estimates include 30% estimate contingency.

³² This suggested option came late in the NPAS effort and has been in active discussion since early September 2014 when NPAS concluded. As a result of this timing this option was not considered by the MST and this section is included only for completeness of the record of the considerations discussed.

The estimate assumes the use of NASA facilities for the non-nuclear EM system testing, including launch vibration testing, mission environment testing, and a one-year extended duration thermal-vacuum performance test leading up to Critical Design Review (CDR), with continued post-CDR testing up through launch. The SIC would be responsible for end-to-end system design, analysis, and demonstration of readiness for flight.

In contrast to the RPS DDT&E costs, several key FPS tasks would be performed by DOE laboratories during the technology and engineering development phases. These would include casting and machining of the depleted uranium (DU) and highly enriched uranium (HEU) cores by a qualified fuel provider, e.g., Y12 or Babcock and Wilcox Technical Services Group (BWXT), nuclear technology demonstration testing at the Nevada National Security Site (NNSS), UMo fuel irradiation testing and post irradiation examination (PIE) at an appropriate DOE Laboratory, e.g., INL, ORNL, or Pacific Northwest National Laboratory (PNNL), and pre-flight safety and security analysis and documentation. If in-core heat pipes are to be utilized, a DOE laboratory would lead the technology development for thermal and structural bonding of the heat pipes to the fuel.

In addition to the costs presented in this study, another cost element that would require development is the cost to sustain the Fission Reactor capability within the DOE national laboratories. A FPS could be used to power space missions at a cadence commensurate with NASA science missions, but there will be periods in which the program is not actively producing a reactor for flight. In order to keep the program viable, a sustainability cost would be incurred. These costs are associated with maintaining facilities and keeping personnel and equipment certified for flight system production involving special nuclear materials (SNM). Such costs include the procurement of materials, control storage and shipment of SNM, fuel fabrication capability, core components fabrication capability, storage and staging of fabricated components, and maintenance of a reactor system assembly area and associated equipment. This sustainment cost requires further study.

The costing methodology for the 1-kW_e TE and 10-kW_e Stirling FPS included a scaling factor³³ applied to the cost estimates generated for the 1-kW_e Stirling FPS, based on the thermal power rating of the reactor. The scaling factor for the 1-kW_e TE FPS is 1.2 based on its 13-kW_{th} core, while the scaling factor for the 10-kW_e Stirling FPS is 1.5, based on its 43-kW_{th} core. Included in the DOE costs is a one-year EM system nuclear ground test at NNSS, followed by a comprehensive core PIE at an appropriate DOE facility. The DOE would also have responsibility for the reactor flight acceptance test at NNSS and shipment of the flight reactor to KSC. The remainder of the DOE costs associated with launch operations, including all flight safety and security costs, are included in the mission costs (Section 5.5).

5.2.1 | FPS Development

Development of the design reference FPS flight system is estimated to be a 10-year effort (Figure 5-3). The development would begin with a three-year technology development phase that is currently partially funded by STMD (FY2015–FY2017). The current STMD KiloPower Technology Development Project is funded to perform (1) separate effects testing on materials, (2) an integrated components test using electric heat applied to a depleted uranium core in a vacuum chamber, and (3) an integrated components test heated by nuclear fission at the Device Assembly Facility (DAF). There are additional technology development activities required beyond the STMD effort including (1) a Phenomena Identification and Ranking Table (PIRT) UMo fuel assessment, (2) fuel irradiation effects testing, and (3) initial safety and security studies. The technology development phase would end with a NASA Pre-Phase A Study. The engineering development phase is estimated to last four years and would include (1) a detailed design of the reactor system, (2) a long-term, electrically-heated system test, (3) a one-year nuclear ground test, (4) vibration testing, (5) impact testing, (6)

³³This scaling factor was used as a multiplier on the reactor cost estimates to account for additional complexities associated with the higher-power reactor cores. For example, the 1 kW_e-Stirling (4.3-kW_{th}) reactor engineering costs were estimated at \$15M based on subject matter expert (SME) input. The 13-kW_{th} core engineering costs were scaled by 1.2x to \$18M, and the 43-kW_{th} core engineering costs were scaled by 1.5x to \$22.5M. The scaling factors were determined by the SME and applied to all reactor cost elements that were influenced by the reactor core thermal power.

and environmental testing. More detailed studies involving safety, security and NEPA processes would be carried out as well. This engineering development phase would culminate in a CDR and a decision on authority to fabricate and test the flight system. The final phase of the project would be a three-year flight system development phase. This would include final design, flight qualification testing, and development of the final safety and security documentation. The flight system development phase would result with delivery of the flight hardware and required documentation to proceed to ATLO. The SIC would be responsible for end-to-end system design, analysis, engineering development and demonstration of readiness for flight.

	Technology Development Phase 2015–2017 (3 yrs)	Engineering Development Phase 2018–2021 (4 yrs)	Flight Systems Development Phase 2022–2024 (3 yrs)
Program	CD	CR PrPhA	CA PDR CDR
			ATLO
System Engineering	<ul style="list-style-type: none"> Mission Concept Review Pre-Phase A study Phenomena Identification and Ranking Technique (PIRT) study 	<ul style="list-style-type: none"> Quality Assurance Plan Requirements & system review Studies (analysis of normal and accident conditions) Engineering design and review 	<ul style="list-style-type: none"> Final design & review Final approvals Launch processing
NASA	<ul style="list-style-type: none"> Electrically heated DU test at GRC 	<ul style="list-style-type: none"> Engineering model hardware Engineering model environment test Long term electrically heated DU test 	<ul style="list-style-type: none"> Flight Hardware Fabrication Flight qualification test Continued electrically heated DU test
DOE	<ul style="list-style-type: none"> Nuclear heated test at DAF using HEU Irradiation test at a university or DOE lab 	<ul style="list-style-type: none"> Long term nuclear test at NTS using HEU Post irradiation examination of core 	<ul style="list-style-type: none"> Flight reactor acceptance test at NTS
Safety & Security	<ul style="list-style-type: none"> Studies 	<ul style="list-style-type: none"> Preliminary EIS & SAR 	<ul style="list-style-type: none"> Final EIS, SAR & INSRP

CD = Concept Development
 CR = Concept Review
 PrPhA = Pre-Phase A study
 CA = Contract Award

PDR = Preliminary Design Review
 CDR = Critical Design Review

ALTO = Assembly, Test & Launch Operations
 EIS = Environmental Impact Statement

SAR = Safety Analysis Report
 INSRP = Interagency Nuclear Safety Review Panel

FIGURE 5-3 | 1-kW. FPS NOTIONAL DEVELOPMENT PLAN

5.3 | System Study Team Cost Elements by Phase

The System Team approach to generating the DDT&E cost estimates included the identification of key deliverables by phase, as shown in Table 5-1. Common across all reference systems in this report is a NASA Management and Integration (M&I) function, DOE/SIC technical oversight, Independent Verification and Validation (IV&V), and DOE/SIC contractor-to-mission technical coordination. All reference system DDT&E cost estimates include one flight unit. The 16-GPHS ARTG deliverables include SKD/LaTe/Zintl couple and module technology maturation leading to a SIC qualification unit, with parallel system engineering to guide the development. The 6-GPHS SRG deliverables include continued fleet testing of the ASRG hardware assets by GRC with parallel convertor and controller technology maturation leading to separate SIC-provided EM and qualification units.

TABLE 5-1 | REFERENCE SYSTEM COST ELEMENTS BY PHASE

System	Technology Development	Engineering Development	Flight System Development
16-GPHS ARTG (350W _e EOM)	<ul style="list-style-type: none"> • SKD/LaTe/Zintl Technology Development • Couple Technology Maturation • TE Development • System Engineering 	<ul style="list-style-type: none"> • Qualification Unit • Management & Integration 	<ul style="list-style-type: none"> • Flight Unit • Management & Integration
6-GPHS SRG (300W _e EOM)	<ul style="list-style-type: none"> • ASRG Fleet Testing • Convertor, Controller, System Technology Maturation 	<ul style="list-style-type: none"> • Engineering Model (EM) & Qualification (Qual) Units • Management & Integration 	<ul style="list-style-type: none"> • Flight Unit • Management & Integration
1-kW _e Stirling FPS	<ul style="list-style-type: none"> • STMD KiloPower Technology Development Project • Convertor, Controller, Development and System Integration (leverages SRG) • Phenomenology Identification and Ranking Table • UMo Fuel Post Irradiation Examination (PIE) • NASA Pre-Phase A Study 	<ul style="list-style-type: none"> • Reactor EM & Qual Units • Balance of Plant EM & Qual Units • Nuclear Safety Testing • EM Non-nuclear System Test (with depleted Uranium core) • EM Nuclear System Test (second hardware set with highly enriched Uranium core) • EM Reactor Core PIE • Management & Integration 	<ul style="list-style-type: none"> • Flight Reactor • Flight Balance of Plant • Reactor & Balance of Plant Integration • Reactor Acceptance Test • Reactor Shipping • Management & Integration
1-kW _e Thermoelectric (TE) FPS	<ul style="list-style-type: none"> • TE Development (leverages ARTG) • In-core Heat Pipe Integration 	<ul style="list-style-type: none"> • 1.2X Reactor & System Qualification Costs 	<ul style="list-style-type: none"> • 1.2X Reactor & System Acceptance Costs
10-kW _e Stirling FPS	<ul style="list-style-type: none"> • Convertor, Controller Development and System Integration (leverages P2A) • In-core Heat Pipe Integration 	<ul style="list-style-type: none"> • 1.5X Reactor & System Qualification Costs 	<ul style="list-style-type: none"> • 1.5X Reactor & System Acceptance Costs

The FPS design reference systems studied share common technology products, including the STMD-funded KiloPower Technology Demonstration Project, UMo PIRT, UMo fuel-sample testing and PIE, and safety studies. The 1-kW_e TE and 10-kW_e Stirling FPS also share the need for in-core heat pipe technology maturation. All FPS options include one DU-fueled EM system for non-nuclear testing, one HEU-fueled EM system for nuclear testing with post-test core PIE, and one DU-fueled qualification system. The FPS cost elements also include a flight reactor acceptance test at NNSS and delivery of the flight reactor to KSC. The system-specific deliverables for the 1-kW_e Stirling FPS include an augmentation of the SRG technology maturation to address FPS-specific requirements (e.g. reactor-induced radiation) and Balance of Plant (BOP) integration for the eight Stirling convertors. Similarly, the 1-kW_e TE FPS would include an augmentation of the ARTG technology maturation to address the differences associated with TE leg geometry, spring-loaded mechanical attachment, operating temperature, and radiation environment. The system-specific deliverables for the 10-kW_e Stirling FPS would include technology maturation for the larger P2A-derived Stirling convertors and evolved, transformer-based, electrical controller. The cost methodology assumed cost scaling factors of 1.2× and 1.5× for the 1-kW_e TE and 10-kW_e Stirling FPS, respectively, based on the increased thermal power rating of their reactor cores.

5.4 | System Design, Development, Test and Engineering Cost Summary

The ROM DDT&E costs for the five design reference systems are presented in Table 5-2 and graphically in Figure 5-4. From a DDT&E perspective, the total system costs fall into three groupings. The RPS options cost

about \$200-250 million, the 1-kW_e FPS about \$400-450 million, and the 10-kW_e FPS about \$700 million. The technology development costs for the Stirling and TE 1-kW_e FPS options assume savings based on leveraging the RPS development, i.e., the RPS development is a required prior effort.³⁴ The engineering development phase for the RPS options is considerably less than the FPS, based on following an established process that has been performed for prior RPS. The FPS engineering costs are also dominated by the need to perform a full-power, ground, nuclear test at the NNSS and an extended-duration EM system test at NASA. The RPS flight unit values include costs for the SIC deliverables plus NASA M&I. The FPS flight unit costs add the cost of reactor acceptance testing at NNSS and shipment of the HEU reactor to KSC.

TABLE 5-2 | DESIGN, DEVELOPMENT, TEST AND ENGINEERING COST SUMMARY

	Technology Development	Engineering Development	Flight System Development	Total Design Development Test & Engineering
16-GPHS ARTG (350 W _e EOM)	51	138	34	223
6-GPHS SRG (300 W _e EOM)	65	130	44	239
1 kW _e Stirling FPS	29	316	80	425
1 kW _e TE FPS	50	311	95	456
10 kW _e Stirling FPS	101	496	115	712

NPAS ROM SYSTEM COSTS (FY14 \$M)
INCLUDING 30% ESTIMATE CONTINGENCY

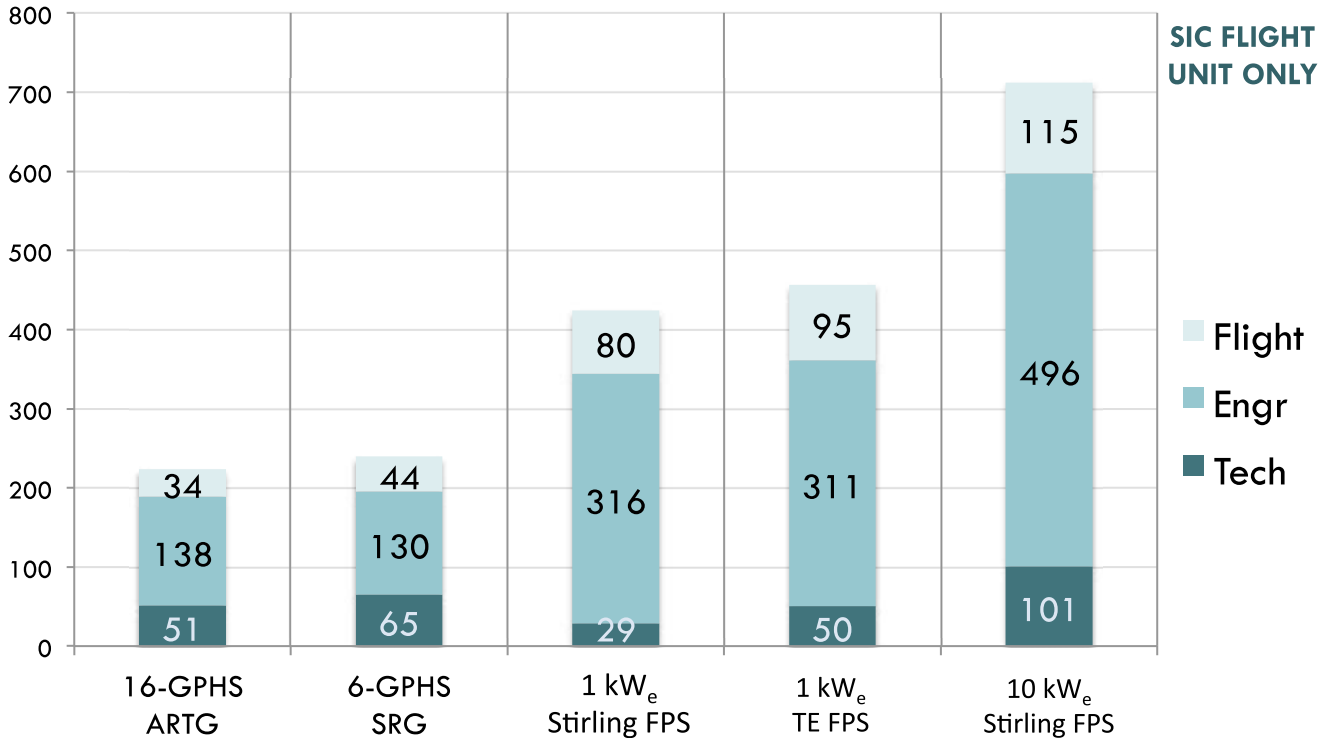

FIGURE 5-4 | NPAS CONCEPT SYSTEM TECHNOLOGY, ENGINEERING, & FLIGHT SYSTEM DEVELOPMENT COSTS, GRAPHICAL SURVEY

³⁴ Even with the prior RPS effort the exact level of cost savings will depend upon the detailed requirements of and schedules for both system efforts.

Both the SST and the MST estimates exclude any costs associated with a fueled qualification unit for the RPS systems, either SRG or ARTG. The cost for producing a qualification unit is included in the SST estimates for both systems, but not for fueling it. This approach came about due to current uncertainty on whether a radioisotope heat source fueled qualification unit would be required for SRG, ARTG, neither, or both. The recent ASRG effort had included a fueled qualification unit as part of its baseline. The recent MMRTG campaign did not fuel a qualification unit. Although such a unit was planned early on, it was abandoned prior to the fueling of the flight unit for MSL. If at a later time a need for a fueled, qualified unit is identified, these costs will need to be added into the SST cost estimate. While the heat sources that are used for a qualification unit are generally not recyclable into a flight unit, they can be chemically recycled and new heat sources reconstituted at LANL so that material is not “lost” and the cost for those heat sources is not attributable to the qualification unit wholly. The costs associated with fueling and testing the qualification unit would be a valid SST cost, however. It was also unclear to what extent a fueled qualification unit would be expected to be on long-term test, thus incurring additional nominal costs. Due to these uncertainties in the potential need for a fueled qualification unit and the in utility of long-term testing no firm consensus on the costing was reached at this time. If a fueling and testing campaign for a qualification unit were to be undertaken for either SRG or ARTG as part of a campaign leading to a flight unit production the likely costs would be several millions of dollars. If such a campaign was done as part of a stand-alone fueling and testing of the qualification unit, the costs would be higher.

A distinction worth noting concerns the difference between the RPS and FPS estimated fuel cost and how these have been tracked. For the RPS, the plutonium dioxide fuel production costs are included with the mission costs (Section 5.5) and additional costs are associated with Pu-238 infrastructure and operations (Section 5.6). The FPS HEU fuel material costs are currently projected to be negligible, and so taken as zero, based on the use of HEU material from the Office of Nuclear Energy’s Research and Space Reactor HEU account.

The infrastructure to produce and test Depleted-Uranium (DU) and HEU cores for KiloPower conceptual experiments currently planned by STMD is also presumed to be zero cost to NASA in this study because infrastructure being used is already supported by DOE and the program is well within the established nuclear safety basis at the facilities. Development and testing of future flight systems are likely to require infrastructure investments to support hardware modifications, facility modifications, and nuclear safety basis upgrades in the test facilities. However, such costs require further study and were not included in this report.

The NASA cost associated with delivering HEU reactor cores for testing or flight is the cost of fabricating (e.g. casting, machining) the HEU into the required reactor-core geometry is included in the DDT&E estimates. Other reactor components may be needed based on the as-yet-developed mission requirements, but those needs and costs are not yet known.

As noted previously, there may be a future sustainment cost to NASA to maintain mission specific equipment created as part of the system development effort, as well as to keep the qualifications of people, processes, and procedures in order. This topic requires further study.

Based on the DRSs selected for this study and the cost assumptions of the study, the total FPS DDT&E costs include the cost of a fueled flight unit, whereas the RPS DDT&E estimates exclude the plutonium dioxide fuel costs (the plutonium dioxide costs for flight units are captured in the mission cost section).

An important figure-of-merit for space nuclear systems is the recurring cost per unit of electrical power output. Generally, nuclear power systems require a large up-front investment to complete the DDT&E, but the recurring unit costs can be relatively small from an overall mission cost perspective. The best-performing system concept on a recurring unit cost basis is the 10-kW_e Stirling FPS at \$115/W_e. Of course, this benefit would be realized only for missions that could utilize a 10-kW_e power source. The 350-W_e ARTG, excluding

fuel, 1-kW_e Stirling FPS, and 1-kW_e TE FPS all resulted in a recurring unit cost in the \$800-\$1000/W_e range. The 300-W_e SRG, excluding fuel, recurring unit cost was approximately \$1,500/W_e.

5.5 | ROM Mission Cost

The total mission ROM costs estimation efforts provided the following findings:

- Total nuclear mission launch costs appear to be insensitive to nuclear power system type, once power system technology and infrastructure development is completed.
- The required mission power level may drive total mission costs for RPS missions that would need power levels above ~1 kW_e.
- Total mission cost comparisons between the TE and Stirling-based RPS missions did not reveal any significant cost deltas.
- One of the main discriminators for RPS options is the cost to fuel the generators.
- Total increases in non-nuclear mission cost (~\$ 200 million) were found using FPS instead of RPS at the 1-kW_e power level.
- Expect minimal change to the cost profile for NASA Launch Approval Engineering and Launch Services Program costs for FPS compared to RPS.
- Security costs for FPS are significant (~\$ 70 million) compared to RPS.

5.5.1.1 | Design Reference Mission ROM Cost Generation Approach – Mission Concepts

The Mission Study Team used the NASA Work Breakdown Structure (WBS) to categorize the mission costs so that the cost impacts to specific segments of the mission from the proposed new power systems could be easily identified. The team used a two-pronged approach to better assess the impact of the proposed new power systems to the two DRM total mission costs. The first prong of the approach was to develop all of the “non-nuclear mission costs” with mission designers during the design sessions, focusing on the development of spacecraft and mission operations costs. To extract the non-nuclear mission costs from the previous studies, the team removed from the total mission cost all costs associated with the previously studied power system, nuclear launch costs, the launch vehicle costs, the ESA in-situ element costs (for the TSSM DRM), and other non-power-system, technology-related items. For comparison, the previous TSSM study cost estimates were then inflated to fiscal year 2015 dollars. Since the 2008 TSSM study cost estimates were in fiscal year 2014 dollars and the other decadal studies were in fiscal year 2015 dollars, the 2008 TSSM study cost estimates were inflated to fiscal year 2015 dollars using the “nominal” NASA inflation rate (3.00% in going from FY2014 to FY2015 amounts) for comparison purposes. These non-nuclear mission costs are discussed in Section 5.5.2.

The second prong of the cost estimation approach was to develop the “nuclear mission cost” estimates with the ATLO team, which includes the cost of the proposed new power systems, along with all nuclear power system-associated ATLO and launch costs. These nuclear mission costs are discussed in Section 5.5.3. For this cost analysis, the team assumed that the nonrecurring cost for the power systems had already been retired and only the recurring cost to reproduce a power system unit was included in the estimates. The DDT&E costs for each proposed power system are provided in Sections 5.1 to 5.4. Then, the team summed the non-nuclear and nuclear mission costs to develop the total mission costs. The total mission costs were estimated for the thermoelectric and Stirling RPS for both the TSSM and UOP missions. The total mission costs were only estimated for the thermoelectric and Stirling FPS for the TSSM mission. As discussed in Chapter 2, the UOP mission did not work with the FPS option considered and using the same constraints as the decal mission study; therefore, a final design reference mission and its total mission cost for the FPS option was not produced.

5.5.2 | Non-Nuclear Mission Cost Analysis Findings

Table 5-3 shows the summary of non-nuclear mission costs for the UOP RPS, TSSM RPS, and TSSM FPS study results for each proposed power system. SRG Option A includes an extra SRG to provide for redundancy as discussed in Chapter 2. This option would have a mass impact on the structures and this results in increased cost. Detailed descriptions of the cost information for each mission are provided in subsequent sections. Non-nuclear mission cost data that was generated during the design session indicates that no significant difference would be found between the total mission cost when evaluating the DRMs with different RPS. However, there would be an increase of approximately \$200 million to the DRM’s total mission cost when evaluating the FPS. This cost increase is primarily due to the increases in system mass, system complexity, and mission duration.

TABLE 5-3 | SUMMARY OF NON-NUCLEAR MISSION COSTS (FY15 \$)

	Mission Costs Less Nuclear Launch Cost* (\$ M)		
	UOP – RPS	TSSM - RPS	TSSM – FPS
Decadal Study	1,516	2,499	2,499
SRG Option A	1,524	2,436	2,634
SRG Option B	1,516	N/A	N/A
TE Option	1,527	2,411	2,661

* Removed power system cost and removed estimated nuclear mission launch costs

5.5.2.1 | UOP 2014 RPS Study

The mission-level cost breakdown results generated by the APL ACE Lab Study Team for the 2014 UOP RPS study are summarized in Table 5-4. The first column lists the elements of the baseline 2010 UOP study, while the remaining three columns correspond to the selected 2014 RPS SRG and ARTG system options costs. Cost elements that changed relative to the 2010 UOP study baseline are highlighted in yellow. All costs shown are in fiscal year 2015 millions of dollars, allowing for direct comparison to the corresponding 2010 decadal study costing results, which also were published in fiscal year 2015 dollars.

The 2014 SRG Option B, which would use two 4-GPHS-module SRGs, exhibits no discernable change to the non-nuclear costs relative to the 2010 UOP baseline configuration. Cost differences for both the SRG and ARTG 2014 UOP options relative to the 2010 baseline are minimal except in the area of communications. The cost differences are due to the modified communication approach adopted for those options and its impact to Mission Operations and DSN cost items. Changes in Project Management, Systems Engineering, and the Safety & Mission Assurance are due solely to the fact that they are estimated as a percentage of other costs (using cost estimating relationships or CERs).

Table 5-5 shows additional detail for WBS 6.0: “Spacecraft.” Cost elements that changed relative to the 2010 UOP baseline are outlined for emphasis. The increased structure/mechanical cost for the ARTG option is the result of adding thermal isolating brackets to the ARTG. The cost reductions shown in RF Communications for two of the selected options is the result of removing the mono-pulse tracking and decreasing the size of the HGA as a mass-saving option. The HGA size reduction partially offsets the mass increases introduced by the 2014 power system concepts relative to the 2010 ASRG quoted masses. All other non-nuclear spacecraft costs remain unchanged from the 2010 baseline.

In summary, based on currently available information, the total non-nuclear-related mission costs estimated for the selected 2014 RPS replacement options are all within 0.7 percent of the 2010 ASRG-based cost estimate.

TABLE 5-4 | 2014 NPAS UOP RPS MISSION NON-NUCLEAR RELATED COST BREAKDOWN COMPARISON (\$M)

NASA WBS	Description	Uranus Decadal 2010 excl. ASRGs	SRG Option A (2+1) x 4-GPHS	SRG Option B 2 x 4-GPHS	ARTG 2 x 9-GPHS
	Phase A	6	6	6	6
01	Project Management	48	47	48	47
02	Systems Engineering	67	66	67	66
03	Safety & Mission Assurance	43	42	43	42
04	Science/Technology (Phases A-D)	15	15	15	15
05	Payloads	27.4	27.4	27.4	27.4
06	Spacecraft	321	313	321	315
07	Mission Operations	156	155	156	155
08	Launch Vehicles & Services	–	–	–	–
09	Ground Data Systems	17	17	17	17
10	Systems Integration & Test	57	57	57	57
DSN	Space Communications Services (DSN)	34	57	34	57
Subtotal		1,049	1,062	1,049	1,064
Cost Reserves		467	462	467	463
Total		1,516	1,524	1,516	1,527

* Changes from the Decadal Survey are outlined.

TABLE 5-5 | 2014 NPAS UOP RPS WBS 6.0 SPACECRAFT NON-NUCLEAR COST BREAKDOWN COMPARISON (\$M)

Spacecraft Description	Uranus Decadal 2010 excl. ASRGs	SRG Option A (2+1) x 4-GPHS	SRG Option B 2 x 4-GPHS	ARTG 2 x 9-GPHS
Cruise Stage	150	150	150	150
SRM Stage	–	–	–	–
Orbiter	171	164	171	165
Structure/Mechanical	7	7	7	9
Propulsion	31	31	31	31
Guidance & Control	23	23	23	23
IEM/Avionics	20	20	20	20
Power System Electronics	20	20	20	20
Thermal Control	2	2	2	2
RF Communications	25	17	25	17
Harness Assembly	2	2	2	2
Flight Software (FSW)	21	21	21	21
Test Beds	19	19	19	19
Total	321	313	321	315

* Changes from the Decadal Survey are outlined.

5.5.2.2 | TSSM 2014 RPS Study

Table 5-6 shows the cost breakdown for the TSSM RPS study results produced by the JPL Team X exercise. All of the non-nuclear mission costs are in fiscal year 2015 millions of dollars. The 2008 ASRG column provides the baseline 2008 TSSM study cost estimate, inflated to fiscal year 2015, with the RPS and their associated nuclear mission launch costs removed. The other two columns contain the 2014 study results for the 6-GPHS SRG and 16-GPHS ARTG options. Rows with cost changes relative to the 2008 TSSM study have values outlined for emphasis.

This comparison shows no significant difference, except in the spacecraft subsystem, WBS 6.0. The changes to 1 Project Management, 2 Systems Engineering, 3 Safety & Mission Assurance, and 10 Systems Integration & Test are due to the fact that they were estimated as a percentage of flight system cost (using CERs).

TABLE 5-6 | 2014 NPAS TSSM RPS MISSION NON-NUCLEAR-RELATED COST COMPARISON (\$M)

NASA WBS	Description	2008 ASRG*	SRG (3+1) x 6-GPHS	ARTG 3 x 16-GPHS
01	Project Management	130	124	124
02	Systems Engineering	48	46	46
03	Safety & Mission Assurance	86	82	82
04	Science/Technology	185	185	185
05	Payloads	260	260	260
06	Spacecraft	702	639	620
07	Mission Operations	294	294	294
09	Ground Data Systems	74	74	74
10	Systems Integration & Test	56	54	54
DSN	Space Communications Services (DSN)	68	68	68
Subtotal		1,902	1,826	1,807
Cost Reserves		597	611	604
Total		2,499	2,436	2,411

* 2008 ASRG column displays 2008 TSSM Study costs inflated to FY 15 with ASRG and associated nuclear mission launch costs removed

** Changes from the Decadal Survey are outlined.

The additional detail for WBS 6.0 Spacecraft is provided in Table 5-7. A review of this data shows:

- The non-RPS portion of the power subsystem cost decreases from \$52M to \$35M due principally due to the use of fewer batteries.
- The telecomm subsystem cost decreases from \$76M to \$54M due principally to use of a smaller antenna.
- For the 16-GPHS ARTG case, the thermal subsystem cost falls to \$11M due to adopting a passive radiative heating conceptual approach using the waste heat from the ARTGs.
- The structural costs decreases from \$121M to \$101M; however, most of this change is due to different study assumptions, and the original TSSM design was re-evaluated at \$105M.

In summary, there is a decrease in estimated non-nuclear mission cost from baseline for both of the RPS cases. This is the result of successfully reducing spacecraft complexity using the additional available power, as discussed in Chapter 2.

TABLE 5-7 | 2014 NPAS TSSM WBS 6.0 SPACECRAFT NON-NUCLEAR COST COMPARISON (\$M)

Spacecraft Description	2008 ASRG	SRG (3+1) x 6-GPHS	ARTG 3 x 16-GPHS
Flight System Management and Engineering	54	52	52
SEP Stage	127	127	127
Orbiter	521	460	441
Structure/Mechanical	125	103	103
Propulsion	51	41	41
Guidance & Control	62	62	62
IEM/Avionics	52	52	52
Power System Electronics	52	35	35
Thermal Control	29	30	11
RF Communications	76	54	54
Harness Assembly	12	20	20
Flight Software (FSW)	49	49	49
Test Beds	14	14	14
Total	702	639	620

* Changes from the Decadal Survey are outlined.

5.5.2.3 | TSSM 2014 FPS Study

The non-nuclear mission cost-breakdown results produced by the GRC COMPASS Team for the 2014 TSSM FPS study are summarized in Table 5-8. The first column lists elements of the baseline 2008 TSSM study, inflated to fiscal year 2015, with all the power system and associated nuclear launch costs removed. The next two columns provide the 2014-study, non-nuclear mission costs for accommodating both the Stirling FPS and TE FPS options. Rows with cost changes relative to the 2008 TSSM study have values outlined for emphasis.

TABLE 5-8 | 2014 NPAS TSSM 1 kW_e FPS MISSION NON-NUCLEAR COST BREAKDOWN COMPARISON (\$M)

NASA WBS	Description	2008 ASRG*	2014 Stirling FPS	2014 TE FPS
01	Project Management	130	130	130
02	Systems Engineering	48	48	48
03	Safety & Mission Assurance	86	86	86
04	Science/Technology	185	185	185
05	Payloads	260	260	260
06	Spacecraft	702	792	806
07	Mission Operations	294	307	313
09	Ground Data Systems	74	74	74
10	Systems Integration & Test	56	56	56
DSN	Space Communications Services (DSN)	68	68	68
Subtotal		1,902	2,005	2,025
Cost Reserves		597	629	636
Total		2,499	2,634	2,661

*2008 TSSM Study costs inflated to FY 15 without nuclear launch costs.

** Changes from the Decadal Survey are outlined.

The spacecraft cost increases to both 2014 TSSM FPS options are primarily due to additional mass increases of the overall spacecraft to accommodate the increased mass of the FPS. Spacecraft accommodations or modifications would be required for the mission to close due to greater propellant loading, increased Solar Electric Propulsion stage array power, and structure mass (payload adaptor, longer fairing, drag flap, etc.). The COMPASS Team applied their cost models to the 2008 ASRG option, as well as the 2014 Stirling FPS and 2014 TE FPS options, in order to have a consistent approach to determine differences in spacecraft cost (WBS 6.0). These differences were applied to the inflated 2008 ASRG estimate of \$702M to calculate the 2014 Stirling FPS and 2014 TE FPS costs.

The Mission Operations cost estimates also increase with both FPS options. The primary cost increase is due to mission design changes because the SEP stage is required to spiral out for approximately one year and the more massive TE FPS would require the SEP stage to spiral out for two years.

In summary, the estimated non-nuclear costs of the TSSM FPS missions increase approximately 5% for the Stirling FPS and 6% for the TE FPS options over those of the original 2008 TSSM Study.

5.5.3 | Nuclear Mission Power System and Launch ROM Cost Generation Approach

The NASA RPS Program Office’s Planning, Programming, Budget and Execution (PPBE) Cost Estimation WBS structure was employed to document mission launch nuclear safety costs for TSSM and UOP. All estimated costs were normalized to fiscal year 2015 dollars and mid-range cost numbers were used if a range of cost data was supplied, as in the Launch Service Provider area. The following key inputs were used during nuclear power system and nuclear mission launch cost estimation activities:

- Notional spacecraft configuration produced from DRM studies using the System Study Team’s nuclear power system characteristics.
- Assumption that DOE allocates 35 kg of Pu-238 isotope for use by NASA, which is sufficient material to provide for fueling a total of seven MMRTG for use with the nominal planning set being: one MMRTG for Mars 2020, one MMRTG for a notional Discovery class mission launch in approximately 2022, and five MMRTGs for a 2024 launch of a Europa mission.³⁵
- Use of the “preferred option” for ATLO of new nuclear power systems at KSC, discussed in Section 2.3.
- DOE costs apply the 2011 MSL mission experience as a basis for the cost estimate.
- Security costs are a bottoms-up estimate using DOE-INL labor rates and equipment costs. Physical upgrades were estimated based on similar recent DOE facility values.

5.5.3.1 | Descriptions and Assumptions for Nuclear Mission Cost Items

The following areas provide a description of each cost element in Table 5-9, along with associated assumptions. Costs associated with the INSRP process are not borne by the mission, but by the organizations supporting INSRP, and as such, are not included in the cost estimates.

³⁵ Subsequent to the completion of this study NASA announced that the notional Europa Clipper mission would use solar arrays rather than MMRTGs.

TABLE 5-9 | NUCLEAR MISSION COST ITEMS

WBS	WBS TITLE	WBS Elements
A.0	NASA Management and Integration	<ul style="list-style-type: none"> • Management of Nuclear Power Systems (NPS) work for Mission Integration, Test, and Launch Operations • Systems Engineering and Integration • Integral part of Mission, paid by Radioisotope Power Systems Program
B.0	DOE Nuclear Powered Mission Support	<ul style="list-style-type: none"> • System Integration Contractor (Flight Unit generation and engineering support thru ATLO at KSC) • Idaho National Lab (INL) (Mission support to DOE, RPS Assembly, Testing, Nuclear Power System Delivery to KSC Group Ops) • Los Alamos National Lab (LANL) (Pu-238 Heat Source Fabrication) • Oak Ridge National Lab (ORNL) (Fabrication of iridium cladding, General Purpose Heat Source Graphite Components) • ORNL (Technical Management Support) • URS Corp. – Washington Safety Management Solutions (Quality Assurance Oversight and Risk Management) • Sandia National Lab (SNL), Other [National Environmental Policy Act (NEPA*) Launch Safety] • Various Radiological Contingency Planning (RCP*) and Emergency Planning • Engineering Consultants • NPS Management Reserve (MR) – (RPS: 30%; FPS: 50%) • DOE Federal Administrative Charge (FAC) (3%)
B.1	Pu-238 Oxide Cost Based On Current Pu-238 Supply Project Estimate	<ul style="list-style-type: none"> • Pu-238 Fuel Cost
C.0	DOE/NASA Security Considerations	<ul style="list-style-type: none"> • Security Considerations
D.0	NASA Launch Approval Engineering (LAE) – JPL	<ul style="list-style-type: none"> • Management & Infrastructure • Compliance Engineering (NEPA, PD/NSC-25, Radiological Contingency Planning) • Aerospace Nuclear Safety Engineering (Databook, Test, etc.) • Risk Communication • NASA NEPA Contractor (NASA HQ SMD Contract, Producer of the EIS, estimated cost) • Launch Site Night Launch Capability
E.0	NASA Launch Service Program (LSP) Support – KSC	<ul style="list-style-type: none"> • Facility Management / New Launch Site Facility (DOE cost estimate for new or modified RTGF) • Launch Service Mission Unique Modifications / Mission Unique Services (2014 PPBE estimate for 2025 launch) • Health Physics (Ground Ops radiological monitoring oversight and support, and radiological contingency planning and launch support) • Launch Site Radiological Contingency Planning (RCP*) & Launch Support (Facility and Monitoring Equipment Readiness/Planning, Exercising, and Launch Deployment Readiness)

* Cost between DOE and NASA are not double booked

A.0 NASA Management and Integration Costs

NASA management and Integration costs include management of nuclear power systems work for mission integration, test, and launch operations, covering needed systems engineering and integration activities. This is an integral part of nuclear mission success that is paid by the RPS Program. These estimates are based on those experienced during the MSL mission development. It is assumed that the cost estimate for these activities for a FPS would be on the same order as those experienced for a RPS.

B.0 DOE Nuclear Powered Mission Support Costs

There are several key assumptions for the cost estimates for DOE-provided services. The first is that the following missions would launch before the DRMs: the Mars 2020 mission would be launched in July 2020 with one MMRTG, a notional Discovery-class mission with one MMRTG would be launched in 2022, and a Europa mission would be launched in 2024 with five MMRTGs. These missions would consume the existing plutonium dioxide fuel supply, which consists of existing domestically-produced material and material purchased from Russia. Therefore, the DRMs studied would require new fuel that would be produced after the successful completion of the Pu-238 Supply Project. The first new domestic supply of plutonium dioxide would be delivered from ORNL to LANL in approximately August 2022. The nominal full production rate is currently estimated at 1.5 kg per year, which equates to approximately 1.1 kg of Pu-238 isotope. These rates determine the GPHS module production rate. The number of potentially fueled RPS is estimated based on various Pu-238 production rate scenarios of 1.5, 3.0, and 5.0 kg plutonium dioxide per year as provided in Table 3-6 and Table 3-7. Lastly, it is assumed that the installation of the additional hot press and ancillary equipment to produce heat sources at Los Alamos National Laboratory would be fully funded and completed on schedule by the end of fiscal year 2017.

The DOE Nuclear Powered Mission Support costs include various activities to ensure the success of a nuclear mission. Those activities are listed below for an RPS. For an FPS, the costs are assumed to be equal to that of one RPS:

System Integration Contractor - Power System (SIC) would entail the actual production costs for a generator, flight-unit generation.

Mission support to DOE, RPS assembly, testing, nuclear power system delivery to KSC, group ops by the Idaho National Laboratory (INL) would include the cost of taking the heat sources from LANL, building them up into GPHS modules, fueling the generator and performing acceptance testing. Any development of tooling and fixtures for new RPS designs would be included. The typical product cycle is 5-6 years. Tooling/fixtures run 3-4 years working closely with the SIC. This is then followed by procedure development and readiness reviews. The actual fueling and testing takes several months. The RPS is then delivered to KSC approximately 4-6 months prior to launch and ground support is provided. The safety basis for nuclear operations at KSC and during transportation is the responsibility of the INL. A continual presence up to and through launch is maintained to deal with the nuclear safety basis and any contingency operations. The bulk of the funding is spent preparing tooling, fixtures, procedures and readiness reviews. The readiness reviews have to be re-done if more than 12 months lapses between operations.

Fabrication of iridium cladding, General Purpose Heat Source graphite components by Oak Ridge National Laboratory (ORNL) would include production of plutonium dioxide for heat sources and the safety verification tests using an impact gun to maintain the safety basis for flight status. If LWRHUs are needed they would be provided by LANL.

Technical Management Support by ORNL includes the chief engineer's effort that supports the federal project manager for a flight program and production of the iridium cladding and carbon-

carbon components. In order to keep proficiency, these items are produced on an annual basis in small numbers under the DOE Operations and Analysis work as described in Section 5.6.2. Specialized materials testing is conducted frequently in response to support development or production needs. A campaign to support a specific mission is budgeted here.

Quality assurance oversight and risk management by URS Corp - Washington Safety Management Solutions. This sub-contractor provides DOE-HQ with quality assurance oversight resources to cover all aspects of the production and delivery of a flight-certified RPS. All national laboratories and contractors that provide product that could be associated with a flight system are subject to oversight by this entity.

National Environmental Policy Act (NEPA) and launch safety support by the SNL or key sub-contractors. NASA leads NEPA activities but DOE provides support. The roles are somewhat different for launch safety, for which NASA provides the databook for the launch vehicle/mission and DOE prepares the nuclear safety analysis. This information feeds into the Presidential Directive/National Security Council Memorandum #25 compliance process that culminates in a request for launch approval from the President's Office of Science and Technology Policy (OSTP).

Various Radiological Contingency Planning (RCP) and Emergency Planning. The emergency planning effort and communication effort associated with a launch of nuclear space power systems involves many groups and lasts over several years. The radiological contingency effort involves in excess of 100 individuals who are involved with the Radiological Control Center (RADCC) and associated facilities, as well as in teams out in the field to monitor for release of material in the event of a launch accident. The teams are scattered over many miles of the coastline and inland based on prevailing weather patterns.

Technical support through ATLO by the Systems Integration Contractor (SIC) includes a full time equivalent engineer to consult with for fueling, testing, and general power systems questions. This could be included in the SIC mentioned above but is broken out here explicitly.

Engineering Consultants. A sub-contractor of senior RPS engineering resources provides DOE-HQ with assistance in key areas associated with manufacturing and performance of RPS.

NPS Management Reserve (MR) - 30%/50%. Considering the various areas of the process have their own contingency levels based on risk and level of knowledge, this can be refined in the future as more information about the new systems are available. 30% is used herein for RPS and 50% used for FPS, given that RPS systems and associated processes are very familiar where FPS are not and have a higher technical, schedule and cost risk.

DOE Federal Administrative Charge (FAC) (3%). This is an administrative charge (levied on NASA) per 42 U.S. Code § 7259a - Activities of Department of Energy facilities.

B.1 Plutonium Dioxide Costs

Plutonium dioxide cost estimates for NPAS are based on the current Pu-238 Supply Project estimate to produce a one-year supply of fuel. This cost is used as a multiplier against the quantity of plutonium dioxide that each studied mission power system would require. This cost is applicable only to RPS.

C.0 DOE/NNSA Security Costs

DOE/NNSA Security Costs include the security cost based on the amount of special nuclear materials (SNM) FPS would use at KSC. It covers both personnel and infrastructure costs. Details of these costs can be found in Section 4.3.

D.0 NASA Launch Approval Costs

There are a number of assumptions that are made in support of the costs estimates for this study. The cost estimates are based on the assumption that the NASA Space Launch System (SLS) with a direct trajectory is used. A night launch is the baseline, given that it is deemed the most conservative launch mode for LAE cost-estimate development. In addition, it is assumed the following costs are covered by another NASA program area and are excluded from these estimates: SLS costs for detailed vehicle-specific information for representative and SAR data book development; SLS costs for launch vehicle studies, design and implementation of flight termination system (FTS) or automatic destruction system (ADS), if required for nuclear safety; costs of any additional environment testing that may be required following accident-scenario definition; and additional NEPA analyses (swing-by, etc.) if required by alternatives assessment.

Further, the estimate excludes consideration for potential need for program-level EIS for reactor development action, or facility NEPA actions that could be required for reactor development/test or processing at launch site. This increment is likely between \$1.5- \$2.5M per document.

The ANSE costs assume no SLS multi-mission data book (MMDB) information available, requires full development activity for Representative databook. The estimate also includes LAE support of mission-specific EIS, but excludes consideration for potential need for program-level EIS for reactor development action, or facility NEPA actions that could be required for FPS development/test or processing at launch site, either in parallel or serially with mission-specific EIS. The NEPA contractor costs estimated at \$2.0 million and the night launch capability development and implementation estimated at approximately \$1 million, considered to be mission cost.

The first-time use of an FPS would involve several considerations, which include early and continued interaction between the Launch Approval Engineering team and the FPS design team, which will reduce the risk of later difficulties with the NEPA and launch approval process and subsequent cost escalations. In addition, changes in FPS design after the NEPA analysis is completed might lead to difficulties with the launch approval process or a re-start of the NEPA process, with associated delays and cost escalation.

NASA Launch Approval costs include engineering activities that are required to ensure mission launch nuclear safety and success. These five areas are described below.

(1) **Management & Infrastructure:** Specify requirements, coordinate, integrate and review lab-wide aerospace nuclear safety engineering, risk communication, and Launch Approval Engineering activities necessary to satisfy regulatory and agency requirements including, National Environmental Policy Act (NEPA), Presidential Directive/National Security Council Memorandum #25 (PD/NSC-25), Federal Radiological Emergency Response Planning (FRERP), Interagency agreement provisions between NASA and United States Department of Energy (DOE) pertinent to Launch Approval Engineering, international treaties and agreements pertinent to launch approval engineering, and other legal and

regulatory requirements related to the assessment and mitigation of potential adverse environmental effects of space missions; coordinate the various interfaces with NASA HQ, other NASA Centers, the DOE and other agencies related to satisfying these requirements.

(2) Compliance Engineering (NEPA, PD/NSC-25, Radiological Contingency Planning): Provide support to NASA HQ in satisfying the requirements of Presidential Directive/National Security Council Memorandum #25 (PD/NSC-25) and NPR 8715.3, NASA General Safety Program Requirements, for flight projects that involve the launch of radioactive materials or might have large-scale or protracted effects on the physical or biological environment. Provide support to NASA HQ in satisfying the requirements of NEPA and NASA regulations for implementation (14CFR1216) and NPR 8580.1A. Provide support to NASA HQ in satisfying the requirements of the Federal Radiological Emergency Response Plan with regard to the launch of radioactive materials. Includes interfacing with contractors, government agencies, and headquarters in support of the launch approval processes.

(3) Aerospace Nuclear Safety Engineering (Databook, Testing, etc.): Support NASA/KSC in preparing Launch Vehicle Databooks to support analyses required for NEPA documentation and Nuclear Safety Analyses prepared by the U. S. Department of Energy when special nuclear materials (SNM) are included in the spacecraft.

(4) Risk Communication: Provide a coordinated approach to communication with the media, public, educators, legislators, and governmental bodies about NASA missions that may have environmental or safety issues of greater than ordinary concern to members of these groups. Represent the interests of the project and the RPS Program at all communication planning meetings and reviews, and provide liaison function with internal JPL offices, NASA HQ, and other industrial partners/subcontractors as required. Typical NASA risk communication products and activities include Talking Points, Responses To Queries, Fact Sheets, formal communications effectiveness training for key project spokespeople, support for social media activity, and a project-specific Risk Communication Plan.

(5) NASA NEPA Contractor (NASA HQ SMD Contract, Producer of the EIS, estimated cost): Support NASA/HQ in ensuring procedural compliance with NASA requirements for the National Environmental Policy Act NEPA, as described by NPG 8580.1, Procedures and Guidelines for Implementing the National Environmental Policy Act and Executive Order 12114. Includes representing the project at all NEPA Compliance meetings and reviews and providing liaison function with NASA HQ, and other industrial partners/subcontractors as required. Documentation products may include contributions to NEPA Compliance Documentation, such as an Environmental Assessment (EA) or an Environmental Impact Statement (EIS).

Launch Site Night Launch Capability: These costs are provided to accommodate for the first-time night launch capability with a FPS, as these resources are not currently available. Although this is the one of KSC/LSP cost elements, it was included here only for bookkeeping purposes to ensure it was not overlooked.

E.O NASA Launch Service Provider (LSP) costs

The first-time launch of a FPS at KSC would involve several considerations. The more definitive the design of the flight FPS—particularly physical size and configuration—the better that the launch site can assess facility needs and launch vehicle integration strategies and impacts. The design, launch site test requirements, and integration strategies for FPS would greatly influence launch site operations and facility needs. The launch site does not yet have experience supporting FPS processing and there would be a learning curve, just as there was with RPS. Without a mature FPS system design, the launch site facilities and processing cost impacts are difficult to bound. FPS requiring significant changes to launch vehicle flight hardware—particularly the launch vehicle fairing—would have significant cost impacts to the launch service contract and possibly to

launch site facilities. Early understanding of both new RPS and FPS processing scenarios would allow the launch site to recommend least-cost, least risk launch vehicle modifications and/or provide work-around strategies so that the launch vehicle modifications are not required. If possible, an FPS-based, mission-operations scenario should minimize changes to integrated launch vehicle operations or procedures, since operational changes are not as difficult, nor as costly or risky, as rocket design changes.

There are four main areas of potential work that were costed as part of this study:

(1) Facility management and new launch site facility (DOE cost estimate for new or modified RTGF) includes staffing, operations, and maintenance of the launch site facilities that are used for processing of the spacecraft, the spacecraft power system components, and/or the special nuclear material required for a mission using nuclear power sources. To date, two NASA-owned and managed KSC facilities have been used for ATLO processing of all nuclear-powered missions: the Payload Hazardous Spacecraft Facility (PHSF), and the RTG Facility (RTGF). A 1-2 month activation/readiness certification of these facilities is included, along with six months of dedicated staff support, 24/7 continuous operations, and utilities for all ATLO activities leading up to launch. The costing also includes spacecraft and DOE post-launch, pack-up and departure support, generally 1-2 weeks post launch. KSC has provided the range of estimated cost data utilizing existing facilities and known MMRTG or SRG nuclear materials to support a 2025 launch or considering a new launch site processing facility that would be built for handling FPS nuclear materials with more stringent DOE security requirements. For ATLO ROM-cost generation, a mid-range number is used.

(2) Launch service mission-unique modifications or mission-unique services includes items such as oversized fairing access doors, special dedicated Ground Support Equipment (GSE), launch vehicle modifications to track nuclear materials in case of accident, launch service provider procedure changes or enhanced security support at the launch pad or other non-government owned (contractor) facilities, or minor changes to launch service provider facilities to accommodate the special needs of that mission. Using a conservative approach, the LSP estimate is based on actual (Pluto-New Horizons and MSL) costs of launch vehicle modifications or special launch vehicle requirements and escalated out to a 2020 launch services contract award for a launch in 2025. For ATLO ROM cost generation, a mid-range number is used.

(3) Health physics includes ground operations radiological monitoring oversight and support, and radiological contingency planning and launch support at the launch site. This task provides personnel and monitoring equipment to staff and support the launch of spacecraft carrying special nuclear materials. It pays for radiological monitoring personnel at the payload processing and nuclear material handling facility, for vehicles, monitoring equipment acquisition, calibration, and maintenance as well as periodic training of health physics personnel and practice exercises. This cost also assumes support of the nuclear material/mission pathfinder (typically 12 – 18 months prior to the launch date, a one – two month activation/preparation period, and 6 months of daily ATLO operations through launch. This line works in close concert with RADCC planning and launch support (see below).

(4) Launch-site Radiological Contingency Planning (RCP) and launch support [facility and monitoring equipment readiness/planning, exercising, and launch deployment readiness] includes facility and equipment maintenance, operations, and staff support of the launch site Radiological Control Center (RADCC) to ensure proper planning, notification of the public, and coordination among local, state, and federal agencies in case of a radiological release during ATLO processing or launch.

5.5.3.2 | TSSM 2014 RPS and FPS Study – Nuclear Mission Launch Cost Analysis Findings

Table 5-10 shows the summary of nuclear mission cost estimates for the UOP RPS, TSSM RPS, and TSSM FPS study results. The cost increases of the 6-GPHS SRG and the 16-GPHS ARTG options are driven by the plutonium dioxide costs. The mission costs for TSSM also are driven by both fuel costs and the number of RPS required. For the FPS option, the security costs are a driver due to the investment in personnel and facilities required to meet government regulations. In addition, the additional structure required by the TE FPS option increased the costs as compared to the Stirling option.

TABLE 5-10 | TSSM 2014 STUDY–PRELIMINARY NUCLEAR MISSION LAUNCH COST ANALYSIS FINDINGS (\$M)

Description		RPS (1 unit)		RPS (1kW _e)		FPS (1kW _e)			
		Single Unit		TSSM		TSSM			
		Existing Facility						Stirling	TE
		1 x 6-GPHS Stirling	1 x 16-GPHS ARTG	4 x 6-GPHS Stirling	3 x 16-GPHS ARTG				
A.0	NASA Management and Integration Costs	11	11	11	11	11	11		
B.0	DOE Nuclear Powered Mission Support Costs	123	128	303	264	128	144		
B.1	PuO ₂ Costs	33	89	133	267	0	0		
C.0	DOE/NNSA Security Costs	0	0	0	0	72	72		
D.0	NASA Launch Approval Costs	13	13	13	13	14	14		
E.0	NASA Launch Service Provider Costs	33	33	33	33	35	35		
Total Cost		210	270	490	590	260	280		

- Normalized all costs to FY15
- Used the mid-range number when ranges of cost data was provided by KSC

5.5.4 | Total Mission Cost Analysis Findings for 2014 TSSM Study

Table 5-11 shows the summary of the 2014 TSSM study total mission cost for the RPS and FPS study results. The total mission costs appear to be in family, relative to the 2008 study, and insensitive to nuclear power system type once power system development is completed. Lastly, while the additional power provided by the proposed RPS and FPS systems was shown to benefit spacecraft communication, these changes to the communication subsystem were not necessary, and the additional available power did increase the overall cost of the mission.

5.6 | NPS Non-Mission/Non-System Costs

In order to support future missions, NASA and DOE need to maintain the capability to produce RPS. The financial support for this capability is provided by NASA and is not attributed to the mission or nuclear power system costs. An approach has been developed for RPS. NPAS applied the same approach in defining potential sustainment needs for FPS. As is discussed elsewhere within this report, the underlying conversion technologies are common between RPS and FPS and therefore, the required sustainment approaches would have much in common. Relevant items include sustainment of skills, capabilities, and infrastructure, all of which include both human knowledge bases as well as “brick-and-mortar” facilities.

TABLE 5-11 | 2014 NPAS TSSM STUDY–PRELIMINARY NUCLEAR MISSION COST ANALYSIS FINDINGS** (\$M)

	RPS			FPS	
	2008 ASRG	SRG (3+1) x 6-GPHS	ARTG 3 x 16-GPHS	Stirling	TE
EOM Power (W_e)	541	891	1,041	1,015	1,015
Mission Cost w/o nuclear components	2,499*	2,436	2,411	2,634	2,661
Power System + ATLO + Nuclear Launch Cost**	215***	490	590	260	280
Total Mission Cost w/o Launch Vehicle	2,714	2,926	3,001	2,894	2,941

* 2008 TSSM Study costs inflated to FY 15 using 3% rate

** Power System + ATLO + Nuclear Launch Cost is normalized to fiscal year 2015 dollars and mid-range cost numbers where used if a range of cost data was supplied, as in the Launch Service Provider area

*** Uses 2008 cost estimates for Power System + ATLO + Nuclear Launch Cost – Launch Vehicle Cost, which did not include fuel costs or other DOE costs

5.6.1 | RPS and FPS Skills and Capabilities Sustainment

Between launches, NASA must maintain the capability to produce RPS for future missions in a timely and cost-effective manner. To aid this process, NASA levied a requirement on the RPS Program [159] stating that “The RPS Program shall sustain current and future RPS capabilities and the necessary support functions to provide for future missions as required.” The objective behind this requirement is to make certain that RPS expertise, capabilities, and infrastructure would be supported between implementing missions as a means to maintain a repository of corporate knowledge and lessons learned.

This top-level requirement led the RPS program, working with the DOE, to determine the capabilities that need to be maintained. The process used had four steps: 1) Identify current critical and key RPS capabilities; 2) Identify RPS critical and key capabilities that can be covered by funded in-line work; 3) Identify risk of losing the RPS capability; 4) Develop sustainment recommendation. The RPS Program’s definition of sustainability is: Long-term management of critical or key Government and Contractor competencies, skills, and facilities. Management means to strategically (in content and timing) and economically balance these critical and key assets across the RPS Program portfolio to meet NASA needs.

Applying the process described, the following key competencies and skills were identified: 1) Thermoelectric principles, materials, and couple development, modeling, testing, and production, and supporting laboratories; 2) Stirling principles, convertor development, modeling and testing, and supporting laboratories; and, 3) nuclear risk analysis, probabilistic risk assessment, accident scenario modeling and analysis, risk communications, radiological contingency planning, and compliance engineering and planning. For each of the thermoelectric and Stirling conversion areas, sustainment-funding levels of \$4 million per year are currently baselined for in-house government capabilities and \$3 million per year for industry. For the nuclear launch approval capabilities, \$2 million per year is baselined for in-house capabilities. Given the current NASA budget for missions and the RPS Program, these levels of sustainment are fully covered by in-line mission costs, support to missions, or technology development work. The sustainment of all of these skills and capabilities and infrastructure is applicable to both RPS and FPS, and does not require additional resources. However, as a FPS is developed, an evaluation of reactor and fuel capabilities and skills would need to be conducted.

5.6.2 | RPS Infrastructure Sustainment

Sustainment capabilities include skills, equipment, and support facilities. The sustainment of the laboratories used to support RPS is included within the skills and capabilities sustainment levels, as these laboratories are required to support the capabilities being sustained. However, DOE formerly funded maintenance of a set of capabilities (facilities, equipment, and core staff) to support the potential mission use of RPS. The FY2014 Congressional appropriation shifted accountability for paying for all associated infrastructure to NASA via an addition of \$50 million per year to the PSD budget, consistent with the National Aeronautics and Space Administration FY2014 President’s Budget Request [71]. NASA chartered a *DOE RPS Infrastructure and Pu-238 Production Zero Base Review* in May 2013 to review the adequacy of the budgeted amounts [73].

The associated arrangements between agencies are documented in a tiered Interagency Agreement (IAA) that supplements the 1991 MOU (cf. Appendix N of [56]). The work sustains a base level of qualified staff and keeps key facilities in an operational mode, including any improvements; a base level of safety and technical analysis capabilities; nuclear materials and systems transportation and storage; and, procurement of hardware as needed to sustain a limited supply chain or to level production rates between missions. In addition, NASA is funding the DOE to sustain industry to produce fine weave pierced fabric (FWPF) for the GPHS module bodies, to reestablish the capability to produce Pu-238 domestically (The Plutonium Supply Project), and to accelerate the installation of a new replacement Hot Press and associated furnaces (at LANL) to support upcoming NASA mission needs.

Table 5-12 provides these recurring funding amounts and Table 5-13 provides the non-recurring funding amounts. The capability to produce Pu-238 upon completion will then require approximately \$10 million per year to be added to the recurring DOE sustainment resources for Operations and Analysis.

TABLE 5-12 | RECURRING DOE FUNDING FOR SUSTAINMENT

	FY14	FY15	FY16	FY17	FY18	FY19	FY20
Operations & Analysis Subtotal	\$48,100	\$49,600	\$53,100	\$54,000	\$57,500	\$59,500	\$60,000
Fine-Weave Pierced Fabric (FWPF)	\$1,000	\$1,000	\$1,030	\$1,060	\$1,090	\$1,090	\$1,100

TABLE 5-13 | NON-RECURRING DOE FUNDING FOR SUSTAINMENT

	FY14	FY15	FY16	FY17	FY18	FY19	FY20
LANL: Hot Press & Furnaces	\$3,200	\$7,800	\$4,200	\$1,000	\$0	\$0	\$0
Pu-238 Supply Project	\$14,500	\$21,400	\$21,400	\$15,000	\$15,500	\$18,500	\$19,000

5.6.3 | FPS Infrastructure Sustainment

The sustainment of the power conversion capabilities for FPS is covered by the sustainment efforts under RPS. Additional sustainment capabilities would be needed in the area of fission reactors and fuels. At this time, because there is no operating FPS, there is no need to allocate resources to sustain the capabilities. As the reactor design matures and if NASA investment in these capabilities progresses, sustainment of FPS capabilities would need to be revisited.

The proposed FPS design makes use of existing DOE material and facilities that are required and maintained by DOE customers and other customers.

6 | FINDINGS

6.1 | Background to Findings

The EC had face-to-face meetings and regular telecons over the course of the study (see Appendix D). In addition, members participated in various meetings of the System Study Team (SST) and Mission Study Team (MST) as well as in site visits and tours, both at NASA and DOE facilities (Appendix D). Some of the detailed material on security issues posed by a launch campaign using a reactor with highly enriched uranium-235 is not publicly releasable and is to be found as a stand-alone report as Official Use Only (OUO) information [160]. Broad findings derive solely from publicly available information.³⁶

6.2 | Findings

The findings developed, while intertwined with each other to some extent, can nonetheless be grouped into three broad categories: technical, sustainability, and management. The first (technical) can be subdivided further into RPS-specific and FPS-specific, although issues associated with converter technologies involve both.

6.2.1 | Technical Findings

In reviewing the various mission concepts and possibilities both from the decadal survey and the DSMCE concepts, as well as from looking at the power requirements for these, including payload, communications, and avionics, the EC concludes the following:

Nuclear power is required and essential for implementing SMD Missions for at least the next two decades.

There are a significant number of scientific investigations articulated in the recent decadal survey [2] that would be enabled by nuclear power. Examples include missions to the outer reaches of the solar system and missions to environments that have limited to no exposure to the Sun (

³⁶ Some members of the EC participated in classified briefings on security at LANL and on DOE hardware capabilities at Y-12. While these briefings provided more depth to the other materials considered by all EC members, they did not provide substantially additional or contradictory materials to what is provided herein.

Table ES-1). It is also clear that the requirements are less than 1 kW_e for all current SMD plans.

Practicalities of current budgets and technical approaches based upon significant past developments and coupled with safety considerations leave open only RPS approaches³⁷ in the near term, unless significant new expenditures and infrastructure developments are to be incurred. FPS using HEU fuel could also be considered an option if mission needs emerge that warrant the required level of investment.

³⁷ This study did not consider the use of RPS based upon light-weight radioisotope heater units (LWRHUs) [161]. Such sources can produce only $\sim 1 \text{ W}_{th}$, and hence $< 1 \text{ W}_e$, and are, therefore, inadequate for primary power for the classes of spacecraft considered here.

6.2.1.1 | RPS specific

The RPS technical investigations conducted by the SST have reiterated that:

RPS is the only currently proven and available implementation approach.

Given currently articulated future PSD needs, it follows that there is a corresponding need to maintain current RTG capability with the MMRTG, the only currently available RPS, as well as to advance higher efficiency TE and Stirling technologies [1]. Dynamic converters have promise for the greatest efficiency increase for SMD future requirements (e.g., a notional $\sim 300 W_e$ generator). Continuing advanced converter development would lead toward program resiliency, i.e., SMD would be able to make mission-planning decisions based on science and programmatic priorities and not be driven solely by Pu-238³⁸ supplies. Such supplies would remain limited unless Pu-238 production is increased beyond currently planned rates (~ 1.5 kg per year plutonium dioxide on average), and options for doing so are worth pursuing. The promise of dynamic power conversion for significantly higher thermal-to-electrical conversion efficiencies is not new, but the historically demonstrated lower risk of a steady-state thermoelectric converter has tended to drive their implementation as long as Pu-238 supplies were adequate, i.e., met the flight-rate demand. Ongoing developments of TE converters and dynamic converters promise better efficiencies, slower degradation rates, and longer lifetimes than currently available with the MMRTG, but each with different levels of development risk.

The most recent attempt to develop dynamic, and in this case Stirling, converters for flight was stopped in October 2013 due to budgetary issues. Nonetheless, the basic technology approach of free-piston Stirling engine converters [166], is believed by many to show the best promise for earliest implementation of high-efficiency dynamic conversion for flight use [167,168]. To salvage as much of that previous effort as possible, an independent technical, cost, management, and risk assessment of ASRG could be a beneficial activity before new converter development is undertaken. Such an assessment could also determine the programmatic value of a flight demonstration.

The MST took a close look at using FPS rather than RPS on high-power PSD missions. Comparisons between the two nuclear systems required looking at what could be done at the 1-kW_e power level for both the TSSM and UOP notional missions because FPS did not provide a resilient replacement for RPS at power levels lower than this. With current planetary decadal mission concepts and currently projected future budget levels for missions, FPS are not applicable to most SMD mission concepts.

Long-term usage by NASA of RPS technology has led to:

RPS infrastructure and usage costs are well known.

NASA usage of RPS³⁹ has provided a solid, 40-plus-year, historical record of performance (dating from 1968 [169,171,172]), and a clear understanding of the costs of implementing RPS on NASA missions. While the costs of RPS infrastructure maintenance and use are not low, the long history of use enables budget and schedule planning with high confidence, and minimizes chances of missing budgetary targets. In addition,

³⁸ The European Space Agency (ESA) is pursuing the use of Am-241-based RPS [162,163] obtained from the reprocessing of spent nuclear fuel from commercial reactors. Such reprocessing is proscribed by law in the U.S. [164], and Am-241 has other technical disadvantages as compared with Pu-238 as well [1,9,165].

³⁹ The first such use was on a technical demonstration mission, first with the aborted Nimbus B launch of 18 May 1968 [169, 170], and then with the successful Nimbus III launch of 14 April 1969 [171,172].

diligence by both NASA (on the spacecraft side) and DOE (on the RPS-supply side) over the years of usage has resulted in implementation efficiencies, which produce the quality product required at the lowest cost.

6.2.1.2 | FPS specific

Motivated by concerns of Pu-238 availability at the time of the planetary decadal survey, a joint NASA / DOE white paper was submitted to the most recent planetary decadal survey [78] and discussed the use of a small, heat-pipe-cooled FPS, similar to concepts that had been studied previously. The MST and SST, as directed by the EC spent a considerable part of their efforts to maximize the alignment of FPS with PSD needs and requirements as a viable alternative to RPS at some time in the future for certain notional missions. The notional FPS baselined here differs significantly from the recent NASA Project Prometheus reactor [32], previously studied reactors, e.g. SP-100 [173], and the previously flown SNAP 10A reactor (U.S.), as well as Buk, Topaz I and Topaz II (Enisey) reactors (Soviet Union)⁴⁰ [174].

Reactors require a critical mass of nuclear fuel to operate, which tends to set a minimum practical size, driven by both the form (isotopic as well as chemical) of the fuel as well as the physical layout of the reactor, reflector, and shielding requirements. Small non-thermal reactors have been studied and used in space.⁴¹ In order to limit the size, and hence mass, of the radiation shield, required to limit the exposure of the spacecraft avionics and instrument electronics to the fission-produced neutrons and gamma-rays that escape from the core, the nuclear fuel should have as high a density of fissile material as is consistent with manufacturability and structural integrity.

One approach to fulfilling this approach is to use uranium very highly enriched in U-235 (>90%) in the form of uranium-molybdenum alloy (UMo). The goal for alloying the Mo component between ~5% and ~10% is to maximize core structural integrity while minimizing the required Mo (non-fissile density) component.⁴² Buk reactor cores used U₃Mo (3% Mo) in the form of loaded fuel pellets [189]; the approach here is to use ~7% to 8% Mo. Such a design is inherently simple with few parts and can provide a small potentially long-lived reactor (at low power).⁴³ The electrical power output can, of course, be reduced to an arbitrarily small level with a corresponding vanishingly small conversion efficiency, but such a reactor would not, of course, be practical due to the associated low specific power (power per unit mass) and low conversion efficiency.

These considerations mesh well with the KiloPower reactor concept [121,191], which has been studied theoretically in some detail and was used as the reference reactor for the FPS considered in this study. The FPS conceptual design was driven by the approach: keep it simple, keep it low-tech, and keep it small. Its core would use uranium molybdenum fuel, with ~7% to 8% Mo in a small number of parts. Such a core design is inherently simple with few parts and could provide a small, long-lived reactor core for the power levels under consideration. For conversion of heat to electrical power, heat pipes would be used to extract the heat from the periphery of the core for lower power levels or from locations within a larger core for higher power levels. Combined with the discussed existing TE convertors [106] or Stirling converters, the approach could lead to a practical “small” FPS for the electrical power range of ~1 kW_e to ~10 kW_e with an upper bound for TE convertors limited to ~4 kW_e. Lower levels of power output are not mass-effective and higher levels than 10 kW_e (corresponding to Stirling convertors and ~40 kW_{th}) produce too high of a fuel core temperature for this core and heat transfer approach to be used.

⁴⁰ There is some commonality with the fuel type used in the Buk reactor, but not in its implementation or other reactor specifics.

⁴¹ The SNAP reactors were “epithermal” with the neutrons partially moderated by the fuel which was uranium zirconium hydride, but this approach can allow the hydrogen to diffuse out of the fuel at operational temperatures, limiting reactor operational lifetime (~a year in 1965).

⁴² This range also tends to minimize the temperature of the phase transition from the γ phase [175–178], a characteristic, which can be important for the use of this fuel [179–188].

⁴³ Concepts have been put forward in the literature using exotic isotopes (U-233 and Cm-245 [35]; Am-241m [190]). However, these do not exist in bulk and there are no production facilities.

Planetary mission costs tend to scale with the spacecraft mass;⁴⁴ too heavy a power supply for a small spacecraft would tend to lead to a higher implementation cost. However, FPS could be used to implement larger SMD Flagship missions than currently envisioned if PSD budgets were to be increased significantly to accommodate such larger missions.

With respect to current budgets and decadal considerations, FPS is not required in order to implement envisioned SMD mission concepts as long as RPS capability is maintained; FPS is a poor technical fit to the current mission set discussed and could not fulfill all requirements in any case. The latter set of requirements flow from landers, rovers, and Montgolfière (hot-air “balloon”)-approaches to exploration, for which mass is at a premium.

The EC included representatives from HEOMD, and they recognize that FPS are likely to be required and essential for implementing HEOMD missions. The current Mars Design Reference Architecture recognizes a need for ~35 to 40 kW_e of electricity in the form of one or multiple FPS units. However, power levels, redundancies, architectures, and corresponding future mission budgets are all yet to be determined for human missions to the Mars surface, which drive this power need. Depending upon the exact Mars human system architectures and exploration strategy selected, the final decisions in these areas could significantly alter nuclear system needs for future crewed Mars surface missions.

As with Pu-238 isotopic fuel supplies, the required FPS U-235 HEU fuel supply has limits. There are 20 metric tons of the required fuel in the U.S., which have been set aside from current and future excess material as it becomes available over the coming years for use in research, space, and medical isotope production reactors [37]. Because only a fraction of the 20 metric tons is set-aside for all U.S. space reactor needs, close coordination between DOE and NASA of supply and demand estimates is required to assure that material demand for NASA missions will not outweigh the supply at any given time.⁴⁵ An additional comparison to Pu-238 fuel supplies is that fuel material and infrastructure costs for HEU to NASA are currently estimated to be negligible.

The conversion technology being developed by SMD (TE and Stirling) is applicable to, and should be highly beneficial for, both RPS and FPS, particularly for the small (≤ 1 -kW_e) systems of interest to SMD. For systems larger than ~ 4 kW_e, only Stirling convertors would be applicable for the assumed design reference systems. Because of cost and complexity issues, it is currently anticipated that HEOMD is likely to be more interested in the larger FPS module sizes of ~ 10 kW_e; however, exact HEOMD power unit sizes cannot yet be determined until further HEOMD assessment and studies are completed.

Fission reactors have never flown from either KSC or CCAFS (SNAP-10A was launched into a near-polar orbit from Vandenberg Air Force Base in 1965). Technical requirements during the launch campaign and the uranium fuel form would entail security requirements over and above those currently in place and used for flying RPS on spacecraft. Overall mission requirements and first-ever costs associated with FPS usage were estimated. FPS SNM Security mission costs at the Cape during ATLO would be very significant (\sim \$70 M). When the design of the FPS system is more mature a more in-depth security vulnerability analysis will allow for a better quality cost estimate for security considerations during ATLO. This analysis may also allow for a limited number of trades to be performed which may involve means of fuel storage, duration of ATLO activities and location of operations at KSC, to name a few of the possible variables. On the other hand, FPS mission costs would not be expected to vary much from historical costs for RPS NEPA or Launch Approval processes (based on the reference FPS assumed in this study).

⁴⁴ This assertion is, for example, born out by the CATE and technical studies for the missions listed in Table ES-1; also, e.g. cf. https://www.nasa.gov/sites/default/files/files/Probabilistic_MassGrowth_Uncertainties_2013.pdf

⁴⁵ DOE tracks requirements, forecasts, estimates and allotments via the Office of Nuclear Materials Integration (ONMI) per the current (10 April 2014) version of DOE Order 410.2

To investigate the feasibility of such small FPS units by NASA, STMD is making an investment (~\$15M) in a technology project using the KiloPower concept [121,191]. This three-year program, just beginning in FY2015, should help demonstrate the technology feasibility, in support of a key decision point (KDP) at end of FY2017.

The current FPS cost estimate fidelity for implementation lags that of RPS. A gap in costing robustness will remain until a new FPS is actually developed for flight and flown.

6.2.2 | Sustainability Findings

With NASA as the primary user of RPS in the U.S., current NASA mission requirements, and the MMRTG and its TE converters as the only currently available approach for providing space nuclear power, a careful balance of maintenance of current capabilities and research and development for improving those capabilities within available funding must be met. Total abandonment either of current capabilities or ongoing research and development will lead to an erosion of capabilities and knowledge base such that the U.S. capability for current RPS and/or future RPS and FPS could be lost. At the same time, the balance must also take into account safe maintenance of required DOE infrastructure and capabilities, production time scales, and the uncertainties associated with NASA missions requiring nuclear power supplies and when those might really be needed.

The FY2014 NASA AMPM [23] calls for two Mars, two Discovery, and three New Frontiers missions between FY2021 and FY2033 (12 years). If all are postulated to be nuclear and use “MMRTG-like” RPS producing 125 W_e at their beginning of life (BOL), we could estimate the Mars missions might require one RPS each, the Discovery missions two such RPS each, and the New Frontiers missions three each for a total of 15 RPS and a total nominal BOL output power of 1875 W_e. This upper limit using current technology would imply a demand of 15 MMRTGs in 12 years. This time period corresponds to new Pu-238 from the Pu-production project now being funded, which would produce 1.5 kg per year of plutonium dioxide, allowing for 9 fueled clads produced per year. With 32 fueled clads per MMRTG the implication is 4 years to supply 1 MMRTG, i.e., a production supply of 3 MMRTGs over the 12-year period. Hence, only 3 out of 15 (20%) of this notional demand could be powered by such MMRTGs using newly produced fuel. Working from an availability vantage point, such a supply implies only one notional, nuclear New Frontiers mission or one notional, nuclear Mars mission plus one notional, nuclear Discovery mission could be flown instead, and there would still be timing constraints in the mission implementation driven by the production rates of the fueled clads.⁴⁶

This is, of course, a very simplistic analysis, leaving out decay (from time of chemical processing of the Pu-238 to use), surge capacity, lead times from fuel delivery to launch, or any improvements to outcomes with fuel blending, but such additional details should not affect outcomes to the point that change the findings here.

This time period for the mission set corresponds to Pu-238 supply and DOE infrastructure costs (to be paid out of NASA’s budget) of ~\$70 M per year.⁴⁷ The cost for each MMRTG (unfueled) is ~\$15M, so 3 produced over 12 years amortizes to an additional ~\$4 M per year (FY2015\$). We can thus estimate that post-2021 sustainment of the MMRTG route would cost ~\$74 M per year with no more than 30% of all robotic

⁴⁶ This is only one of a continuum of scenarios. The FY 2015 AMPM [24] baselines 2 Mars, 4 Discovery, and 2 New Frontiers missions for this period. If all were nuclear with the same number of supplies as assumed with the 2014 AMPM, then 16 supplies would be implied. Here also, material currently available is assumed to be used and/or set aside for other missions prior to 2021, which may not be the case. In addition, plutonium dioxide in each clad is made and processed at different times, leading to differing thermal outputs and the actual power available on a given spacecraft depends on the actual launch dates and margins assumed. Hence, this type of exercise only provides an estimate of what should be available and what might be achieved.

⁴⁷ This is a “sunk” cost, that is, in order to maintain the infrastructure so as to have the capability to produce RPS in the future, this expenditure is needed, and none of this cost is mitigated as a function of to what extent and/or how often the infrastructure is used.

planetary flights using current RPS technology, depending on the category and power usage.⁴⁸ Note that of these funds, ~\$10 M per year is required to sustain the production infrastructure at ORNL with an \$11-14 M per year beyond that for actual production of 1.5 kg per year of plutonium dioxide, the total cost being currently estimated \$21-24 M per year. Hence, the implied cost is ~\$7 to 9 M per kg of plutonium dioxide or ~\$10 to 12 M per kg of Pu-238 isotope (cf. Chapters 2 and 5: the \$10 M per year is a “sunk” infrastructure cost and the \$11-14 M per year is a mission cost for 1.5 kg per year of plutonium dioxide).

There is currently about 35 kg of Pu-238 “on hand” with 17 kg within specification and about 18 kg out of DOE specification (per DOE Memorandum of August 2013 – reprinted in Appendix E of this report). The specification of the amount of Pu-238 is important for the correct characteristics of the FC and other materials to be maintained, to ensure robustness in the event of a potential launch accident, as well as for providing adequate power for the missions. The DOE has indicated that seven MMRTGs could be fueled with this material; for example, Mars 2020, one Discovery mission, and one Flagship mission using five or fewer MMRTGs could potentially be powered with the Pu-238 on hand.⁴⁹ Processing and assembly of fueled clads limit the timeline on which given units can be made available, a situation that will continue with the new Pu-238 as it becomes available. Long-term, e.g. 20-year, schedules thus become important, albeit with frequent, e.g. yearly updates, to take into account the best information on the user (NASA) side. For this planning to work efficiently, it must be a joint DOE and NASA activity.

Flight rates can be increased, but additional funds would be required. There are two different routes: (1) more efficient converters, e.g., segmented TE converters, building upon ongoing efforts at JPL, and/or Stirling converters, building upon past and ongoing efforts at GRC, and/or (2) increased Pu-238 production rates. Under the current environmental impact statement (EIS) and records of decision (RODs) [192,193], up to 5 kg per year of plutonium dioxide could be produced, although an existing, currently unused hot cell at the REDC at ORNL would likely have to be outfitted with equipment and brought on line in order to accomplish this increased rate of production.

6.2.3 | General Observations

Successful implementation of planetary space missions, has always been, and continues to be, a technically difficult undertaking, requiring the technical skills of many people, with diverse technical backgrounds, and not failure-tolerant. The separate development and implementation of nuclear power supplies for spacecraft is, in and of itself, a similarly difficult undertaking, with the addition of multifarious and necessary safety requirements and procedures to guarantee that those requirements will be met. The combination of these two technically demanding and intensive efforts can be – and has been on numerous occasions – carried out successfully. However, all parties are in agreement that this is not an automatic outcome of such efforts, but requires significant proactivity amongst all of the participants. At the top level:

1. Communications between all concerned divisions of NASA (SMD, HEOMD, STMD) and of DOE (NE, NNSA) must remain open in a timely and on-going fashion. Such communications are important, and indeed necessary, for programmatic efficiency, technology development, and achieving successful flight status.
2. Lines of authority, responsibility, and management need to be streamlined for development of flight articles. This has not always been the case in past efforts, and while that lack can be overcome, there is a price to be paid in both schedule and costs.
3. This study has identified communication issues which need to be strengthened as these efforts go forward including:

⁴⁸ If one nuclear Mars and one nuclear Discovery mission of the seven in the 2014 AMPM are flown then the flight rate of nuclear missions is 2/7 ~ 30%. If only one New Frontiers mission is flown the rate would be 1/7 ~ 15%.

⁴⁹ Following the cutoff of new information for this study, the Europa Clipper pre-project made a decision not to use MMRTGs for that mission; this action should free up enough Pu-238 to produce an additional 5 MMRTGs if they were to be needed on a mission for NASA.

- a. SMD and HEOMD coordinate any future requirements, as they evolve, in a timely fashion.
- b. NASA nuclear investments be coordinated both within NASA and with DOE in a united set of requirements.

6.3 | Take Away from the NPAS Effort

This effort has not revealed any unexpected surprises: it remains a fact that nuclear power systems are required to enable high-priority SMD mission concepts recommended by the decadal survey [2]. The power level required for such missions would be $< 1 \text{ kW}_e$ and best met by RPS solutions. Sustaining this capability requires plutonium (Pu-238) production and funding of the maintenance of the associated infrastructure by NASA due to this shift of funding responsibility to NASA in the President's FY2014 budget [71] and as passed by the Congress [72].

FPS does not represent a good fit for SMD missions as currently projected. Due to the size of foreseen FPS concepts it would likely not enable non-orbiting mission (landers and/or rovers⁵⁰), and, would likely not, therefore, enable the breadth and depth of the science discussed in the current decadal survey.

FPS has promise and would likely be required for HEOMD surface missions. Depending on how and when human-crewed, deep-space missions are implemented, it is difficult to see how FPS would not have an enabling role, e.g. for providing surface electrical power at Mars [22].

To meet SMD science needs across cost classes the availability for flight of both thermoelectric and Stirling converters currently appear to be advantageous for the foreseeable future. Advancement of these converter technologies (both static and dynamic) to achieve increased efficiency has direct benefit to future SMD science missions (flybys, orbiters, landers, and rovers). Continued investments are being pursued to provide this advancement and determine the best implementation strategies based on mission-informed system requirements at key decision points in the development. Once successful, these technologies could enable compelling science output by achieving higher power output for longer operational time, balancing plutonium usage and production in support of an increased flight rate. From a NASA perspective, such developments could also help missions remain within budget constraints (more cost-effective implementations), and help retire mission risk (more reliable implementations). In any case, all would be of significant benefit to the space science program.

The physics of dynamic power conversion promises higher conversion efficiency than from TE systems. For the power levels of interest to SMD, and based upon the current understanding of the state-of-the-art technology, Stirling converters appear to offer a better fit than Rankine or Brayton converter units [93,198]. However, Stirling power converters have never been flown. This situation has been a major obstacle to their adoption and use, a situation not unlike that of ion propulsion prior to its implementation on NASA's Deep Space One (DS-1) technology demonstration mission (from 1998 through 2001). Similarly, the pursuit of opportunities for future technology flight demonstration of Stirling power converters could be considered in support of technology maturation and risk reduction. In the meantime, continued efforts to increase converter efficiency and lifetime remain essential.

⁵⁰ A notional fission reactor concept for a Mars lander/rover, the Heatpipe-Operated Mars Exploration Reactor (HOMER) using highly enriched uranium nitride (UN) fuel and Stirling converters to provide 3 kW_e [194] was discussed in the early 2000's for use on Mars [195]. Notional system mass was 775 kg including: reactor mass = 244 kg, shield = 212 kg, Stirling engine = 87 kg, power conditioning, rover, structure, and miscellaneous items 160 kg, and radiator mass of 72 kg [196]. The notional rover: Mars Atomic Rover for Geographic Exploration (MARGE) had a total landed mass of 3,284.2 kg [197] (the Curiosity rover has a landed mass of 899 kg and is powered by one MMRTG).

APPENDIX A: NUCLEAR POWER ASSESSMENT STUDY TERMS OF REFERENCE (TOR)

**NASA Radioisotope Power Systems Program
Nuclear Power Systems Assessment
Terms of Reference
March 15, 2014 (Amended May 2014)**

Background

NASA has pursued different approaches for provisioning nuclear power systems. In recent history, Radioisotope Power Systems (RPS) have been provisioned in support of the Science Mission Directorate (SMD) for robotic exploration. Fission Power Systems (FPS) have been in development in support of Human Exploration and Operations Mission Directorate (HEOMD) goals. Nevertheless, fission and radioisotope power systems have traveled down parallel development paths, requiring separate resources. SMD is considering the possibility of using both RPS and FPS for future missions. This potential approach along with the current budget scenario presents an opportunity to explore development of common power system technologies that feed both FPS and RPS as an alternate provisioning strategy. This strategy may hold the possibility of furthering exploration goals for several mission directorates, while reducing technology risk associated with new systems development.

Objective

Discuss a sustainable strategy and present findings for the provisioning of safe, reliable, and affordable nuclear power systems that enable NASA Science Mission Directorate (SMD) missions and is extensible to Human Exploration and Operations Mission Directorate (HEOMD) needs in the next 20 years.

Stakeholders

Several organizational entities have a vested interest in the activities of this team, the findings and the future investment strategy. These include NASA mission and technology investors, the mission developers, and the Department of Energy (DOE) organizations involved in providing the RPS and potential future FPS. Accordingly, to represent these stakeholders, the executive council will be comprised of the following organizations:

- NASA/SMD, HEOMD, Space Technology Mission Directorate (STMD) – responsible for defining, advocating, justifying, and obtaining funding for NASA space exploration priorities and nuclear technology/system development activities
- Jet Propulsion Laboratory (JPL), Goddard Space Flight Center (GSFC), Johns Hopkins University Applied Physics Laboratory (APL) – responsible for defining and developing missions to meet science objectives
- DOE Office of Space and Defense Power Systems (NE-75), DOE National Nuclear Security Administration (NNSA) – responsible for safely providing nuclear power systems to meet NASA's needs

Duration of Activity

The study will begin in April 2014 and conclude in November 2014.

Deliverables

Deliverables include:

- a) A status briefing will be provided Executive Council to the RPS Program midway during the study (July 2014).
- b) A final presentation with a written report will be delivered Executive Council to the RPS Program Director. The final presentation will be delivered in advance of the written report in September 2014. A written report will be delivered by the Executive Council in November 2014 for unlimited distribution.

Reporting

The Nuclear Power Systems Assessment study is performed by an Executive Council (EC) and two technical tier teams. The technical tier teams will be responsive to the EC to provide the necessary data and information that is required to address the study objective. The Executive Council will report the final output to the RPS Program Director, David Schurr.

Executive Council Chair

Dr. Ralph L. McNutt, Jr. of The Johns Hopkins Applied Physics Laboratory

Executive Council Membership, Operating Mode, and Schedule

- Members:
 - Chris Moore, HEOMD
 - Ryan Stephan, STMD
 - Leonard Dudzinski, SMD
 - Wade Carroll, DOE NE-75
 - Jerry McKamy, DOE NNSA
 - Kim Reh, JPL
 - Mike Amato, GSFC
 - Cheryl Reid, APL
 - Joe Sholtis, Nuclear Safety Consultant
 - Suzanne Aleman, NASA Nuclear Flight Safety Assurance Manager
- Executive Council Secretary
 - Katie Trase, GRC
- Operating Mode
 - The Executive Council will gather information from 2 technical teams. These teams will provide reports and data and perform trades to inform the Executive Council.
- Meeting Dates
 - April TBD, at GRC
 - July TBD, at DOE
 - September TBD & TBD, at NASA HQ
 - Teleconference calls as scheduled
- Technical Support
 - Technical Tier Team 1: Mission Study Team
 - Technical Tier Team 2: Systems Study Team

Issues to be Addressed

In formulating the findings, the Executive Council and Technical Tier Teams will study issues that the NASA decision makers need to consider in determining the provisioning strategy. The following are the study considerations, constraints, and outputs.

Study Considerations:

- Sustainable Technology Development Strategy
 - NASA's goal for higher power efficient systems
 - Technology and system development applicability and breadth to meet current and future mission needs
 - Conversion technology independence and dependence to nuclear source
 - Conversion technology and source independence and dependence to mission needs
 - Common component approaches
 - Conversion technologies state-of-the-art (SOA) and capabilities

- Commonality and unique aspects of components, specifically related to the convertor, controller, and thermal systems.
 - Energy conversion architectures that aggregate smaller components to achieve larger power systems
- Dual applicability of conversion technologies to radioisotope and fission powered systems
- Technology Capability Sustainment
 - Continuity of safety certifications of workforce and facilities
 - Sustainment of industry and government knowledge, capabilities, skills and infrastructure
- Programmatic Feasibility
 - Fuel availability, quality, production, and process limitations to support future mission scenarios
 - Onramps to flight and funding sources
 - Costs, schedules and risks associated with provisioning
- Nuclear safety considerations and processing considerations
 - Safety analysis, safety databooks
 - Energy conversion system ground testing and shipping
 - Launch approval process
- Infrastructure impacts
 - Changes to current DOE infrastructure implied by energy conversion technology and technology development strategy
 - Planning horizon required to modify DOE infrastructure to accommodate technologies and development strategy
- Spacecraft configuration constraints and system integration
 - Internal redundancy to address system and mission reliability
 - Spacecraft integration and operation
 - Assembly, Test, and Launch Operations (ATLO) considerations including launch: launch vehicle (LV) integration, Kennedy Space Center (KSC) operations, and Radiological Contingency Planning (RCP)

Study Constraints

- The Step 2 General Purpose Heat Source (GPHS) is the assumed, standard component for RPS systems.
- No changes to the NNSA, LANL, and Y-12 infrastructure to develop and fuel reactors or test fission systems
- NASA mission scenarios, requirements and timelines as described in the Vision and Voyages for Planetary Science in the Decade 2013-2022
- Mission Planning Scenario
 - Mars (2020)
 - Europa (2024)
 - Future Discovery (between 2025 and 2030)
 - Future New Frontiers (between 2025 and 2030)
 - Future Flagship Missions(post 2030)
- Consideration of potential HEOMD missions that would benefit from nuclear power technologies will be included
 - Mars habitat

- o In-Situ Resource Utilization (ISRU)

Study Output:

- a) Discussion of a strategy/roadmap and rationale of RPS and FPS common component technology development for SMD with possible extension to HEOMD needs
 - i. Top-level requirements for dual components
 - ii. Extensibility to HEOMD future missions
 - iii. If and/or when to convert to or include fission systems
 - iv. Impacts to NASA and DOE infrastructure
 - v. Limitations and/or impacts of radioisotope and fission heat sources
- b) Discussion of flight system development costs, risks and other considerations
- c) Discussion of safety impacts and required analyses of FPS
- d) Identification of follow-on studies or trades requiring further investigation

Technical Team Consultants and Advisors

Integral to the objectives of this study is the development of technical data to support the EC findings. Technical experts in the areas of Mission and System Studies are provided. These two Technical Tier Teams will deliver trade studies, mission and system studies, and operational and infrastructure reports to the Executive Council. The Executive Council may request additional clarification or study input from the Technical Tier Team to support the study objective. These teams will be organizationally diverse and will include technologist, mission (SMD & HEOMD) and systems engineers, as well as nuclear experts from the DOE.

- Young Lee, JPL, will lead the Mission Study Team. This team will provide data on mission power needs, environmental constraints, and processing, infrastructure and vehicle integration constraints. Nuclear Safety, mission impacts and system availability and costs will also be provided. The team will also develop and deliver at least one design reference mission and will leverage those already developed. The team will include:

Name	Org	Role
Paul Ostdiek	APL	Consultant
Rich Anderson	APL	Ace Study Lead/Mission Design
June Zakrajsek	GRC	Consultant/Stakeholder
Bob Cataldo	GRC	ATLO Analysis/ConOps
Steve Vernon	APL	ATLO Analysis/ConOps
Steve Oleson	GRC	Consultant
Young Lee	JPL	Mission Study Team Lead
Brian Bairstow	JPL	System Engineering
David Woerner	JPL	Consultant
Jean-Pierre Fleurial	JPL	Consultant
John Elliot	JPL	Mission Concept (SMD)
Greg Carr	JPL	Power System User -Ops
Michelle Rucker	JSC	Consultant/Stakeholder
Kevin Watts	JSC	Mission Concept (HEO)
TBD	GSFC or JPL	Science Chair
Anthony Belvin	DOE	Consultant/DOE POC/Launch

Larry Craig/Chuck Tatro	KSC	Launch Ops
TBD	GSFC	Consultant
Steve Johnson	INL	Nuclear Processing and Operations
Ron Lipinski	SNL	Safety Analysis
Vicky Ryan	JPL	Launch Approval Engineering

- Lee Mason, GRC, will lead the Systems Study Team. This team will provide data on component trades, GPHS and fission heat source considerations and constraints, dynamic and static power conversion, controller and electrical integration, and dynamic system constraints and considerations. Nuclear safety, system impacts and costs will also be provided. The team will include:

Name	Org	Role
Lee Mason	GRC	Systems Study Team Lead
Paul Schmitz	GRC	Systems Analysis
Marc Gibson	GRC	Fission Systems
Dirk Cairns-Gallimore	DOE	RPS and Pu-238
Anthony Belvin	DOE	Reactors
Jeff Schreiber	GRC	Stirling
Jean-Pierre Fleurial	JPL	Thermoelectrics
Dave Poston	LANL	Reactor Analysis
Patrick McClure	LANL	Nuclear Testing
John Creasy	Y12	Reactor Fuel and HEU
Marty Fraeman	APL	PMAD
TBD	GSFC	System Integration?
Chip Redding	GRC	CAD
Abe Weitzberg	Independent	Consultant
Chris Robinson	Y12	Consultant
Lou Qualls	ORNL	Consultant
Jim Withrow	GRC	Consultant
Wayne Wong	GRC	Consultant
Matt Dolloff	GRC	Consultant
Dave Woerner	JPL	Consultant
Lee Mason	GRC	Systems Study Team Lead

APPENDIX B: STUDY PARTICIPANTS*

Executive Council Membership

RALPH L. MCNUTT, JR., *Johns Hopkins University, Applied Physics Laboratory, CHAIR*
SUZANNE M. ALEMAN, *NASA Nuclear Flight Safety Assurance*
MICHAEL J. AMATO, *NASA Goddard Space Flight Center*
WADE CARROLL, *DOE Office of Space and Defense Power Systems*
LEONARD DUDZINSKI, *NASA Science Mission Directorate*
JERRY MCKAMY, *DOE National Nuclear Security Administration*
CHRISTOPHER MOORE, *NASA Human Exploration and Operations Mission Directorate*
CHERYL REED, *Johns Hopkins University, Applied Physics Laboratory*
KIM R. REH, *NASA Jet Propulsion Laboratory*
JOSEPH A. SHOLTIS, Jr., *Sholtis Engineering & Safety Consulting*
RYAN A. STEPHAN, *NASA Space Technology Mission Directorate*

Alternate Executive Council Membership

MICHAEL L. ADAMS, *NASA Goddard Space Flight Center*
PATRICIA M. BEAUCHAMP, *NASA Jet Propulsion Laboratory*
ALICE CAPONITI, *DOE Office of Space and Defense Power Systems*
STEVEN CLEMENT, *DOE National Nuclear Security Administration*
AMIR H. DEYLAMI, *NASA Space Technology Mission Directorate*
KENNETH E. HIBBARD, *Johns Hopkins University, Applied Physics Laboratory*
PAUL OSTDIEK, *Johns Hopkins University, Applied Physics Laboratory*
JOHN W. WARREN, *NASA Human Exploration and Operations Mission Directorate*

Study Coordinator

JUNE F. ZAKRAJSEK, *NASA Radioisotope Power Systems Program*

Executive Secretary

KATHRYN K. TRASE, *NASA GLENN RESEARCH CENTER*

Mission Study Team Membership

YOUNG LEE, *NASA Jet Propulsion Laboratory, LEAD*
RICHARD ANDERSON, *Johns Hopkins University, Applied Physics Laboratory*
BRIAN BAIRSTOW, *NASA Jet Propulsion Laboratory*
ANTHONY BELVIN, *DOE Office of Space and Defense Power Systems*
GREG CARR, *NASA Jet Propulsion Laboratory*
ROBERT CATALDO, *NASA Glenn Research Center*
LARRY CRAIG, *NASA Kennedy Space Center*
DONYA DOUGLASS-BRADSHAW, *NASA Goddard Space Flight Center*
JOHN ELLIOT, *NASA Jet Propulsion Laboratory*
JEAN-PIERRE FLEURIAL, *NASA Jet Propulsion Laboratory*
DOUG ISBELL, *NASA Jet Propulsion Laboratory*
STEPHEN JOHNSON, *Idaho National Laboratory*

RON LIPINSKI, *Sandia National Laboratory*
STEVEN OLESON, *NASA Glenn Research Center*
PAUL OSTDIEK, *Johns Hopkins University, Applied Physics Laboratory*
MICHELLE RUCKER, *NASA Johnson Space Center*
VICKY RYAN, *NASA Jet Propulsion Laboratory*
RANDY SCOTT, *NASA Kennedy Space Center*
CHARLES TATRO, *NASA Kennedy Space Center*
STEVE VERNON, *Johns Hopkins University, Applied Physics Laboratory*
KEVIN WATTS, *NASA Johnson Space Center*
DAVID WOERNER, *NASA Jet Propulsion Laboratory*
JUNE ZAKRAJSEK, *NASA Glenn Research Center*

APL ACE Members:

RICHARD ANDERSON, *Lead/Systems*
HOLLIS AMBROSE, *G&C*
BETSY CONGDON, *Mechanical*
MARTY FRAEMAN, *Avionics, Power*
JASON GORCZYCA, *S/C Design*
LAUREN MEHR, *Cost*
BRIAN SEQUEIRA, *Telecom*
STEVE VERNON, *ATLO*
BRUCE WILLIAMS, *Thermal*

GRC COMPASS Members:

STEVE OLESON, *Lead*
BRIAN BAIRSTOW, *Science and Payload, (JPL)*
LAURA BURKE, *Mission Design*
BOB CATALDO, *FPS ATLO Processing*
ANTHONY COLOZZA, *Thermal*
STEPHEN JOHNSON, *FPS ATLO Processing, (INL)*
ROBERT JONES, *Communications*
RICH KELSCH, *Structures*
MIKE MARTINI, *Mission Design*
LEE MASON, *Power*
TOM PACKARD, *Spacecraft Configurations*
TOM PARKEY, *Cost*
PAUL SCHMITZ, *Power*
TIM VERHEY, *Propulsion*
STEVE VERNON, *FPS ATLO Processing, Launch Vehicle, (APL)*
JEFF WOYTACH, *System Integration, Mission ConOps, Launch Vehicle*

JPL Team-X Members:

AL NASH, *Lead*

DAVID HANSEN, *Telecom*
MICHAEL MERCURY, *Systems*
JONATHAN MURPHY, *Deputy Systems*
DHACK MUTHULINGAM, *Power*
JAMIE PIACENTINE, *Configuration*
LEIGH ROSENBERG, *Cost*
MATTHEW SPAULDING, *Mechanical*
ERIC SUNADA, *Thermal*
PAUL WOODMANSEE, *Propulsion*

Safety, Environmental Protection, Launch Approval and Security Team

JOSEPH A. SHOLTIS, JR., *Sholtis Engineering & Safety Consulting, LEAD*
RYAN D. BECHTEL, *DOE Office of Space and Defense Power Systems*
STEPHEN JOHNSON, *Idaho National Laboratory*
RONALD J. LIPINSKI, *Sandia National Laboratory*
J. MARK PHILLIPS, *NASA Jet Propulsion Laboratory*
PAUL K. VANDAMME, *NASA Jet Propulsion Laboratory*

Systems Study Team Membership

LEE MASON, *NASA Glenn Research Center, LEAD*
ANTHONY BELVIN, *DOE Office of Space and Defense Power Systems*
DIRK CAIRNS-GALLIMORE, *DOE Office of Space and Defense Power Systems*
JOHN CREASY, *DOE National Nuclear Security Administration*
SAL DISTEFANO, *NASA Jet Propulsion Laboratory*
MATT DOLLOFF, *NASA Glenn Research Center*
JEAN-PIERRE FLEURIAL, *NASA Jet Propulsion Laboratory*
MARTY FRAEMAN, *Johns Hopkins University, Applied Physics Laboratory*
MARC GIBSON, *NASA Glenn Research Center*
STEVE HERRING, *Idaho National Laboratory*
PATRICK MCCLURE, *Los Alamos National Laboratory*
DAVID POSTON, *Los Alamos National Laboratory*
LOU QUALLS, *Oak Ridge National Laboratory*
CHIP REDDING, *NASA Glenn Research Center*
CHRIS ROBINSON, *DOE National Nuclear Security Administration*
PAUL SCHMITZ, *NASA Glenn Research Center*
JEFF SCHREIBER, *NASA Glenn Research Center*
ABE WEITZBERG, *Independent Consultant*
JIM WITHROW, *NASA Glenn Research Center*
DAVID WOERNER, *NASA Jet Propulsion Laboratory*
WAYNE WONG, *NASA Glenn Research Center*

* Participants listed alphabetically

APPENDIX C: ACRONYMS

ACU	ASC Controller Unit
ADS	Automatic Destruction System
AEC	Atomic Energy Commission
ALSEP	Apollo Lunar Surface Experiment Package
AMPM	Agency Mission Planning Model
AMTEC	Alkali Metal Thermal-to-Electric Converter
AO	Announcement of Opportunity
APL	Applied Physics Lab
ARPS	Advanced Radioisotope Power System
ARTG	Advanced Radioisotope Thermoelectric Generator
ASC	Advanced Stirling Convertor(s)
ASD	Astrophysics Science Division
ASRG	Advanced Stirling Radioisotope Generator
ATEC	Advanced Thermoelectric Couple
ATLO	Assembly, Test, and Launch Operations
ATR	Advanced Test Reactor
BAE	Battelle Energy Alliance
BCI	Bare Clad Impact
BOL	Beginning of Life
BOM	Beginning of Mission
BOP	Balance of Plant
CBCF	Carbon-Bonded Carbon-Filter
CBCF	Carbon-Bonded/Carbon-Fiber
CCAFS	Cape Canaveral Air Force Station
CDR	Critical Design Review
CEQ	Council on Environmental Quality
CFR	Code of Federal Regulations
COMPASS	Collaborative Modeling for Parametric Assessment of Space Systems
CSSR	Comet Surface Sample Return

DAF	Device Assembly Facility
DDT&E	Design, Development, Test and Engineering
DEIS	Draft Environmental Impact Statement
DoD	Department of Defense
DOE	Department of Energy
DRA	Design Reference Architecture
DRM	Design Reference Mission
DRS	Design Reference System
DSA	Documented Safety Analysis
DSAR	Draft Safety Analysis Report
DSMCE	Discovery and Scout Mission Capabilities Expansion
DU	Depleted Uranium
DUFF	Demonstration Using Flattop Fissions
EA	Environmental Assessment
EC	Executive Council
EDL	Entry, Descent, and Landing
EDU	Engineering Development Unit
EEV	Earth Entry Vehicle
EGA	Earth-Gravity-Assist
EIS	Environmental Impact Statement
EMI	Electromagnetic Interference
eMMRTG	enhanced Multi-Mission Radioisotope Thermoelectric Generator
EOM	End of Mission
ESA	European Space Agency
ESD	Earth Science Division
FAC	Federal Administrative Charge
FC	Fueled Clad
FEIS	Final Environmental Impact Statement
FONSI	Finding of No Significant Impact
FOV	Field of View

FPS	Fission Power Systems
FPSF	Fission Power System Facility
FR	Flagship Recommendation
FR (AB)	Flagship Recommendation under Augmented Budget
FRERP	Federal Radiological Emergency Response Planning
FSAR	Final Safety Analysis Report
FTS	Flight Termination System
FWPF	Fine-Weave Pierced Fabric
FY	Fiscal Year
GIS	Graphite Impact Shell(s)
GPHS	General-Purpose Heat Source
GRC	Glenn Research Center
GSE	Ground Support Equipment
GSFC	Goddard Space Flight Center
GTO	Geostationary Transfer Orbit
HEOMD	Human Exploration and Operations Mission Directorate
HEU	Highly-Enriched Uranium
HFIR	High Flux Isotope Reactor
HGA	High Gain Antenna
HOMER	Heat pipe-Operated Mars Exploration Reactor
HQ	Headquarters
HSD	Heliophysics Science Division
IAAC	Inert Atmosphere Assembly Chamber
IECEC	International Energy Conversion Engineering Conference and Exhibit
INL	Idaho National Laboratory
INSRP	Interagency Nuclear Safety Review Panel
IV&V	Independent Verification and Validation
JEO	Jupiter Europa Orbiter
JHU	Johns Hopkins University
JPL	Jet Propulsion Laboratory

JSC	Johnson Space Center
KIPS	Kilowatt Isotope Power System
KSC	Kennedy Space Center
LAE	Launch Approval Engineering
LANL	Los Alamos National Lab
LEU	Low enriched uranium
LGN	Lunar Geophysical Network
LSP	Launch Service Program
LWRHU	Light Weight Radioisotope Heater Unit
MAA	Material Access Area
MARGE	Mars Atomic Rover for Geographic Exploration
MAV	Mars Ascent Vehicle
MAX-C	Mars Astrobiology Explorer-Cacher
MC&A	Material Control and Accountability
MER	Mars Exploration Rover
MLI	Multi-Layer Insulation
MLP	Mobile Launch Platform
MMDB	Multi-Mission Data Book
MMRTG	Multi-Mission Radioisotope Thermoelectric Generator
MOA	Memorandum of Agreement
MOU	Memorandum of Understanding
MOX	Mixed Oxide Fuel
MR	Management Reserve
MS	Mission-Specific
MSL	Mars Smart Lander; Mars Science Laboratory
MSR	Mars Sample Return
MST	Mission Study Team
NASA	National Aeronautics and Space Administration
NE	Nuclear Energy
NEP	Nuclear Electric Propulsion

NEPA	National Environmental Policy Act
NEPSTP	Nuclear Electric Propulsion Space Test Program
NEXT	NASA Evolutionary Xenon Thruster
NFC	New Frontiers Candidate
NNSA	National Nuclear Security Administration
NNSS	Nevada National Security Site
NOI	Notice of Intent
NPAS	Nuclear Power Assessment Study
NPR	NASA Procedural Requirements
NPS	Nuclear Power Systems
NRA	NASA Research Announcement
NRC	National Research Council; Nuclear Regulatory Commission
NSC	National Security Council
NTP	Nuclear Thermal Propulsion
OMB	Office of Management and Budget
ORNL	Oak Ridge National Laboratory
OST	Office of Secure Transportation
OSTP	Office of Science and Technology Policy
OUO	Official Use Only
PA	Protected Area
PCU	Power Conversion Unit
PD	Presidential Directive
PEIS	Programmatic Environmental Impact Statement
PHSF	Payload Hazardous Storage Facility
PIE	Post Irradiation Examination
PIRT	Phenomenology Identification and Ranking Table
PMS	Polymer Mass Spectrometer
PNH	Pluto New Horizons
PNNL	Pacific Northwest National Laboratory
PPBE	Planning, Programming, Budget and Execution

PRA	Probabilistic Risk Assessment
PSAR	Preliminary Safety Analysis Report
PSD	Planetary Science Division
RADCC	Radiological Control Center
RCP	Radiological Contingency Planning
RDF	Radiation Design Factor
RHU	Radioisotope Heater Units
ROD	Record of Decision
ROM	Rough Order of Magnitude
RPS	Radioisotope Power Systems
RPSF	Radioisotope Power System Facility
RSIL	RPS System Integration Lab
RTG	Radioisotope Thermoelectric Generator
RTGF	Radioisotope Thermoelectric Generator Facility
SAR	Safety Analysis Report
SBIR	Small Business Innovation Research
SC	Space Craft
SDI	Strategic Defense Initiative
SDPS	Space and Defense Power Systems
SEI	Space Exploration Initiative
SEP	Solar Electric Propulsion
SER	Safety Evaluation Report
SIC	System Integration Contractor
SLC	Space Launch Complex
SLC-41	Space Launch Complex-41
SLS	Space Launch System
SMD	Science Mission Directorate
SME	Subject Matter Expert
SNAP	Systems for Nuclear Auxiliary Power
SNL	Sandia National Laboratories

SNM	Special Nuclear Material
SP	Saturn Probe
SPO	Security Police Officer
SPP	Solar Probe Plus
SRG	Stirling Radioisotope Generator
SSPSF	Space and Security Power Systems Facility
SST	Systems Study Team; Safe Secure Transport
STMD	Space Technology Mission Directorate
TAGS	Te-Ag-Ge-Sb
TAP	Technology Advancement Project
TDC	Technology Demonstration Converter
TE	Thermoelectric
TID	Total Ionizing Dose
ToR	Terms of Reference
TRL	Technology Readiness Level
TSSM	Titan-Saturn System Mission
ULA	United Launch Alliance
UOP	Uranus Orbiter and Probe
US	United States
USAF	United States Air Force
VCHP	Variable Conductance Heat Pipes
VCM	Venus Climate Mission
VIF	Vertical Integration Facility
WBS	Work Breakdown Structure
Y-12	Y-12 National Security Complex

APPENDIX D: KEY DATES

May 1: NPAS Executive Council Kick-off Meeting (Wash DC)
May 28: Mission Study Team Face-to-Face Meeting #1 (JPL)
June 6: Debrief of MST Face-to-Face Meeting #1 summary to EC (Virtual)
June 9-12: Team X Session on Titan Saturn System Mission (TSSM) Stirling-based RPS (JPL)
June 11: MST ATLO Assessment Sub-team kick-off meeting (Virtual)
June 16-July 7: COMPASS Sessions on TSSM FPS (GRC)
June 19-20: ACE Session kick-off on Uranus Orbiter Probe (UOP) RPS (APL)
June 23-24: INL Tour with NPAS EC Chair (INL)
July 7: Team X Session with sub-team on TSSM TE-based RPS (JPL)
July 9-10: System Team Face-to-Face Meeting #1 – Debrief TSSM Quick-look Study Results (GRC)
July 15: TSSM 2014 RPS/FPS Study Results Briefing (Virtual)
July 17-18: MST ATLO Sub-team Security Assessment for New RPS and FPS (KSC)
July 21: NPAS EC Mid-Term MST Status Briefing (Wash DC)
July 24: ACE UOP RPS Study complete (APL)
July 31: UOP 2014 RPS Study Results Briefing (Virtual)
Aug 4 -15: COMPASS Session on UOP FPS (GRC)
Aug 7: MST ATLO Sub-team Launch Ops Face-to-Face Meeting (KSC)
Aug 13-14: System Team Face-to-Face Meeting #2 - Debrief UOP Quick-look Study Results (ORNL/Y-12)
Aug 19: FPS Technical and Security Discussions (LANL)
Aug 26-28: MST Face-to-Face Meeting #2 including UOP FPS Study Results Briefing (JPL)
Sep 2-5: NPAS EC Final Review (Wash, DC)
Nov 28: NPAS Final Report

COLOR KEY:

Meetings at DOE and Launch Facilities

Mission Studies at Collaborative Engineering Centers

APPENDIX E: INVENTORY ALLOCATION OF PLUTONIUM-238 FOR CIVIL SPACE APPLICATIONS



Department of Energy
Washington, DC 20585

AUG 08 2013

Dr. James Green, Director
Planetary Science Division
Science Mission Directorate
NASA Headquarters
Washington, DC 20546

Dear Dr. Green:

To improve communication and transparency in support of the National Aeronautics and Space Administration's (NASA) mission planning process for identifying missions that could potentially use radioisotope power systems (RPS), the Office of Nuclear Energy (NE) has established a plutonium-238 (Pu-238) inventory allocation for civil space applications.

Please see the enclosed memorandum (Enclosure) that establishes that allocation. The allocation is specified in quantities of Pu-238 isotope rather than the final oxide fuel form and includes a combination of material that meets specifications for the General Purpose Heat Source, the basis of current RPS designs, as well as material that does not meet specifications.

As part of the mission planning process, we ask that NASA provide power requirements for missions as part of its mission planning assumptions. In turn, the Office of Space and Defense Power Systems (NE-75) will advise on the likelihood of supporting particular mission scenarios and the power levels that could be achieved for a particular launch timeline using a specific RPS design. Any questions related to the civil space inventory allocation should be directed to the Office of Space and Defense Power Systems, NE-75.

If you have any questions, please contact me at 301-903-6062.

Sincerely,

A handwritten signature in blue ink that reads "Alice Caponiti".

Alice Caponiti, Director
for Space and Defense Power Systems
Office of Nuclear Energy

Enclosure

cc : David Schurr, NASA SMD PSD
Leonard Dudzinski, NASA SMD PSD



Printed with soy ink on recycled paper

United States Government

Department of Energy

memorandum

DATE: July 19, 2013
REPLY TO:
ATTN OF: NE-75
SUBJECT: Inventory Allocation of Plutonium-238 for Civil Space Applications
TO: File

In order to provide increased transparency for mission planning for space exploration purposes, the Office of Nuclear Energy is establishing separate allocations for civil space applications, such as National Aeronautics and Space Administration (NASA) space exploration missions, and for national security applications. Prior to the establishment of this inventory allocation, the Office of Nuclear Energy's Office of Space and Defense Power Systems (NE-75) managed Pu-238 as a single programmatic inventory serving both civil space and national security applications. The primary differentiator in management of the inventory was whether the Pu-238 was domestically produced or procured from Russia. While material procured from Russia may not be used for national security purposes by agreement, domestically produced material has been informally reserved for national security purposes until such time that a domestic Pu-238 production capability is reestablished. The current approach establishes a civil space allocation that is available for planning future space exploration missions. This allocation includes both Pu-238 procured from Russia and a portion of domestically produced Pu-238.

This memorandum establishes an allocation in the amount of 35 kilograms (kg) of plutonium-238 isotope for civil space applications. Of that amount, approximately 17 kg complies with the Pu-238 content specified for the General Purpose Heat Source. The balance may be used as blend stock to increase the net amount of usable material for flight systems. Information pertaining to the civil space and national security allocations shall be handled consistent with classification guidance set forth in TNP-48, *Guidance for Plutonium-238 Inventories*, attached to this memorandum.

Allocations are based on the mass of Pu-238 isotope, not the mass of bulk oxide. NE-75 will assign specific items in the Pu-238 inventory to each allocation in a manner that balances the needs of user communities. Allocations are for planning purposes only and may be adjusted by NE-75 based on evolving national priorities, either in terms of total mass in each allocation or specific items within an allocation. An allocation does not convey any rights to material usage; it is meant to facilitate planning for future mission needs. New Pu-238 produced domestically using NASA funds will be assigned to the civil space allocation. Pu-238 procured from Russia will always remain as part of the civil space allocation. Allocations do not correspond to whether any usage of material requires reimbursement to the Department of Energy; such commitments are tracked separately.

Document attached contains OOU information

NE-75 plans to issue annual updates to this allocation. If there are any questions, please contact me at (301) 903-6062.



Alice K. Caponiti, Acting Director
for Space and Defense Power Systems
Office of Nuclear Energy

Attachment

Document attached contains OUO information

REFERENCES

- [1] National Research Council, *Radioisotope Power Systems: An Imperative for Maintaining U.S. Leadership in Space Exploration*, The National Academies Press, Washington, D.C., 2009.
- [2] National Research Council, *Vision and Voyages for Planetary Science in the Decade 2013–2022*, National Academies Press, Washington, D.C., 2011.
- [3] National Research Council, *Solar and Space Physics: A Science for a Technological Society* National Academies Press, Washington, D.C., 2013.
- [4] J.R. Bates, W.W. Lauderdale, H. Kernaghan, ALSEP termination report, in: NASA Reference Publication, NASA Scientific and Technical Information Office, Washington, D.C., 1979, pp. 165.
- [5] J.E. Lipp, R.M. Salter, Jr., R.S. Wehner, R.R. Carhart, C.R. Culp, S.L. Gendler, W.J. Howard, J.S. Thompson, Utility of a satellite vehicle for reconnaissance, in: Project RAND USAF Project RR 1, Santa Monica, California, 1951, pp. 140.
- [6] J.E. Lipp, R.M. Salter, Project Feed Back Summary Report, in: R-262, The Rand Corporation, Santa Monica, California, 1954, pp. 50–60.
- [7] S.S. Voss, SNAP Reactor Overview, Air Force Weapons Laboratory, Kirtland Air Force Base, New Mexico, 1984, pp. 103.
- [8] G.P. Dix, S.S. Voss, The pied piper—a historical overview of the U.S. Space Power Reactor Program, in: Proceedings of the First Symposium on Space Nuclear Power Systems, Albuquerque, New Mexico, 1984, pp. 8.
- [9] W.R. Corliss, D.G. Harvey, *Radioisotopic Power Generation*, Prentice Hall, Englewood Cliffs, New Jersey, 1964.
- [10] L.S. Mason, J.G. Schreiber, A Historical Review of Brayton and Stirling Power Conversion Technologies for Space Applications, NASA/TM—2007-214976, NASA Glenn Research Center, Cleveland, Ohio, 2007, pp. 15.
- [11] R.K. Shaltens, Future opportunities for dynamic power systems for NASA missions, in: International Stirling Forum 2006 (ISF2006), Osnabruck, Germany, 2007, pp. 20.
- [12] G. Bennett, Dynamic power for defense and exploration: a look at the Department of Energy's 1987 Nuclear Power Sources Assessment Team report, in: 7th International Energy Conversion Engineering Conference, Denver, Colorado, AIAA 2009-4636, 2009.
- [13] G.L. Bennett, J.J. Lombardo, R.J. Hemler, G. Silverman, C.W. Whitmore, W. Amos, E.W. Johnson, A. Schock, R.W. Zocher, T. Keenan, K.J. Hagan, R.W. Englehart, Mission of daring: the general-purpose heat source radioisotope thermoelectric generator, in: 4th International Energy Conversion Engineering Conference and Exhibit (IECEC), San Diego, California, AIAA 2006-4096, 2006, pp. 23.
- [14] K.-P. Wenzel, R.G. Marsden, D.E. Page, E.J. Smith, The Ulysses mission, *Astronomy and Astrophysics Supplement Series* 92 (1992) 207–219.
- [15] D.J. McComas, L.W. Acton, M. Balat-Pichelin, V. Bothmer, R.B. Dirling, Jr., W.C. Feldman, G. Gloecker, S.R. Habbal, D.M. Hassler, I. Mann, W.H. Matthaeus, R.L. McNutt, Jr., R.A. Mewaldt, N. Murphy, L. Ofman, E.C. Sittler, Jr., C.W. Smith, M. Velli, T.H. Zurbuchen, *Solar Probe: Report of the Science and Technology Definition Team*, Goddard Space Flight Center, Greenbelt, Maryland, 2005, pp. 142.
- [16] D.J. McComas, L.W. Acton, M. Balat-Pichelin, V. Bothmer, R.B. Dirling, Jr., W.C. Feldman, G. Gloecker, S.R. Habbal, D.M. Hassler, I. Mann, W.H. Matthaeus, R.L. McNutt, Jr., R.A. Mewaldt, N. Murphy, L. Ofman, E.C. Sittler, Jr., C.W. Smith, M. Velli, T.H. Zurbuchen, *Solar Probe Plus: Report of the Science and Technology Definition Team*, Goddard Space Flight Center, Greenbelt, Maryland, 2008, pp. 130.
- [17] National Aeronautics and Space Administration, *Announcement of Opportunity Discovery 2010*, NASA, Washington, D.C., 2010, pp. 134.
- [18] National Aeronautics and Space Administration, *C.26 Discovery and Scout Mission Capabilities Expansion (ROSES)*, NASA, Washington, D.C., 2007, pp. 5.

- [19] T. Caillat, S. Firdosy, B.C.-Y. Li, C.K. Huang, D. Uhl, K. Smith, J. Paik, J.-P. Fleurial, R. Bennett, S. Keyser, Skutterudite-based advanced thermoelectric couples for integration into an advanced MMRTG, in: ICT2014, International Thermoelectric Society, Nashville, Tennessee, 2014, pp. 1 (abstract).
- [20] National Aeronautics and Space Administration (NASA) Mars Architecture Steering Group, Human Exploration of Mars Design Reference Architecture 5.0, NASA/SP—2009-566, NASA Headquarters, Washington, D.C., 2009.
- [21] National Aeronautics and Space Administration (NASA) Mars Architecture Steering Group, Human Exploration of Mars Design Reference Architecture 5.0—Addendum, NASA/SP—2009-566-ADD, NASA Headquarters, Washington, D.C., 2009.
- [22] National Aeronautics and Space Administration (NASA) Mars Architecture Steering Group, Human Exploration of Mars Design Reference Architecture 5.0—Addendum #2, NASA/SP—2009-566-ADD2, NASA Headquarters, Washington, D.C., 2014.
- [23] National Aeronautics and Space Administration, FY14 Agency Mission Planning Model (AMPM), 2014.
- [24] National Aeronautics and Space Administration, FY15 Agency Mission Planning Model (AMPM), 2014.
- [25] R. Surampudi, B. Carpenter, M.S. El-Genk, L. Herrera, L. Mason, J.F. Mondt, B. Nesmith, D. Rapp, R.L. Wiley, Advanced Radioisotope Power System Team: 2001 technology assessment and recommended roadmap for potential NASA deep space missions beyond 2011 Report, in: Advanced Radioisotope Power Systems Team Report, D-20757, 2001.
- [26] J.F. Mondt, S. Surampudi, B.J. Nesmith, D. Rapp, Advanced radioisotope power system technology development for NASA missions 2011 and beyond, in: Sixth European Space Power Conference, ESA, Porto, Portugal, 2002, pp. 6.
- [27] R.M.S. Williams, V.B. Shields, M.L. Homer, A.K. Kisor, M.A. Ryan, Challenges facing successful development of long life, high temperature, high efficiency/power AMTECs for space applications, in: M.S. El-Genk (Ed.), Space Technology and Applications International Forum—2001, American Institute of Physics, College Park, Maryland, 2001, pp. 1055–1065.
- [28] J.C. Giglio, R.K. Sievers, E.F. Mussi, Update of the design of the AMTEC converter for use in AMTEC Radioisotope Power Systems, AIP Conference Proceedings 552 (2001) 1047–1054.
- [29] T.K. Hunt, R.K. Sievers, J.T. Kummer, J.E. Patolin, D.A. Butkiewicz, AMTEC/SHE for space nuclear power applications, AIP Conference Proceedings 246 (1992) 1316–1324.
- [30] D. Brown, T. Day, T. Caillat, G.J. Snyder, Chemical stability of (Ag,Cu)₂Se: a historical overview, Journal of Electronic Materials 42 (2013) 2014–2019.
- [31] G. Dennler, R. Chmielowski, S. Jacob, F. Capet, P. Roussel, S. Zastrow, K. Nielsch, I. Opahle, G.K.H. Madsen, Are binary copper sulfides/selenides really new and promising thermoelectric materials? Advanced Energy Materials 4 (2014).
- [32] M. Wollman, M. Zika, Project Prometheus Reactor Module Final Report, SPP-67110-0008, U.S. DOE Naval Reactors Division, Washington, D.C., 2006.
- [33] R. Taylor, Prometheus Project: Final Report, Jet Propulsion Laboratory, Pasadena, California, 2005, pp. x and 215.
- [34] W.R. Determan, G.A. Johnson, Sub-kilowatt class fission heat source thermoelectric power study, in: Nuclear and Emerging Technologies for Space, Albuquerque, New Mexico, 2011, pp. 22.
- [35] S.A. Wright, R.J. Lipinski, Mass Estimates of Very Small Reactor Cores Fueled by Uranium-235, U-233 and Cm-245, in: M.S. El-Genk (Ed.) Space Technology and Applications International Forum—2001, American Institute of Physics, Albuquerque, New Mexico, 2001, pp. 875–880.
- [36] United Nations, Principles Relevant to the Use of Nuclear Power Sources in Outer Space, New York, 1993.
- [37] T.P. D'Agostino, Memorandum of agreement (MOA) for implementation and control of highly enriched uranium (HEU) removed from use of fissile material for nuclear warheads, in: Department of Energy (Ed.), Assistant Deputy Administrator for Program Integration, Washington, D.C., 2006, pp. 16.
- [38] Department of Energy, Highly Enriched Uranium: Striking a Balance, DOE, Washington, D.C., 2001, pp. 174.

- [39] G.L. Bennett, R.J. Hemler, A. Schock, Space nuclear power—an overview, *Journal of Propulsion and Power* 12 (1996) 901–910.
- [40] C.L. Stokely, E.G. Stansbery, Identification of a debris cloud from the nuclear powered SNAPSHOT satellite with Haystack Radar measurements, *Advances in Space Research* 41 (2008) 1004–1009.
- [41] The SP–100 Nuclear Reactor Program: should it be continued? in: Subcommittee on Investigations and Oversight, Committee on Science, Space, and Technology, United States General Accounting Office, Washington, D.C., 1992, pp. 15.
- [42] E.B. Bowron to P.V. Domenici, TOPAZ II Space Nuclear Power Program—Management, Funding, and Contracting Problems, Office of Special Investigations, letter B-277078, United States General Accounting Office, Washington, D.C., 1997.
- [43] N.R. Kingsbury, Space nuclear propulsion, in: Testimony Before the Subcommittee on Investigations and Oversight, Committee on Science, Space, and Technology, House of Representatives, GAO/T–NSIAD–93–02, United States General Accounting Office, Washington, D.C., 1992.
- [44] Management Information Services, Inc., 60 Years of Energy Incentives: Analysis of Federal Expenditures for Energy Development, MISI, Washington, D.C., 2011, pp. 59.
- [45] R.E. Engler, Atomic Power in Space: A History, U.S. DOE Office of Nuclear Energy, Science, and Technology, Washington, D.C., 1987, pp. 188.
- [46] J.P. Layton, J. Grey, A compilation of selected nuclear space power reactor characteristics, in: T–SAC Report, Techno-Systems Analysis Corporation, Princeton Junction, New Jersey, 1983, pp. 32.
- [47] A.S. Koroteev, N.N. Ponomarev-Stepnoi, V.P. Smetannikov, A.A. Gafarov, M. Houts, M. Van Dyke, T. Godfroy, J. Martin, S. Bragg-Sitton, R. Dickens, P. Salvail, R. Harper, I. Hrbud, The case of nuclear propulsion, in: AIAA International Air and Space Symposium and Exposition: The Next 100 Years, Dayton, Ohio, 2003.
- [48] J. Ashcroft, C. Eshelman, Summary of NR Program Prometheus Efforts, Department of Energy, Washington, D.C., 2006.
- [49] S.R. Greene, Lessons learned (?) from 50 years of U.S. space fission power development, in: Proceedings from the Space Nuclear Conference 2005, American Nuclear Society Annual Meeting, San Diego, California, pp. 10.
- [50] A.C. Marshall, Space Reactor Safety, 1985–1995 Lessons Learned, Sandia National Laboratories, Albuquerque, New Mexico, 1995.
- [51] P.R. McClure, D.I. Poston, M. Gibson, C. Bowman, J. Creasy, KiloPower Space Reactor Concept—Reactor Materials Study, LA–UR–14–23402, Los Alamos National Laboratory, Los Alamos, New Mexico, 2014.
- [52] F.H. Clauser, D. Griggs, L. Ridenour, G. Peebles, P. Lagerstrom, W. Klemperer, J. Lipp, R. Krueger, E. Graham, R. Shevell, V. Sturdevant, G. Griminger, H. Luskin, B. Baker, E. Bradshaw, E. Wheaton, L.H.D. Wall, Preliminary Design of an Experimental World-Circling Spaceship, Douglas Aircraft Company, Inc., Santa Monica, California, 1946, pp. 340.
- [53] J.E. Lipp, R.M. Salter, Project Feed Back Summary Report, Santa Monica, California, 1954, pp. 127.
- [54] R.L. Mead, W.R. Corliss, Power from radioisotopes, in: U.S.A.E. Commission (Ed.), Division of Technical Information, Oak Ridge, Tennessee, 1963.
- [55] W.R. Corliss, SNAP nuclear space reactors, in: U.S. Atomic Energy Commission (Ed.), Division of Technical Information, 1969.
- [56] J. Casani, G. Burdick, R. Carpenter, T. Frazier, D. McPherson, A. Mehner, J. Parrish, L. Rutger, R. Wilcox, Report of the RPS Provisioning Strategy Team, 2001, pp. vii and 124.
- [57] Atomic Energy Commission, An Interagency Agreement Between the Atomic Energy Commission and the National Aeronautics and Space Administration Concerning Isotopic SNAP Devices for NASA Space Vehicles, AEC/NASA, Washington, D.C., 1965, pp. 8.

- [58] L. Herrera, The U.S. Department of Energy Advanced Radioisotope Power System Program, Intersociety Energy Conversion Engineering Conference, Colorado Springs, Colorado, 1998.
- [59] R. Furlong, R.K. Shaltens, Technology assessment of DOE's 55-W_e Stirling Technology Demonstrator Convectron (TDC), in: 35th Intersociety Energy Conversion Engineering, Las Vegas, Nevada, 2000, pp. 13.
- [60] J.G. Schreiber, Assessment of the Stirling Power Option for Space Science Applications, in: NASA/TM—2000-210234, NASA Glenn Research Center, Cleveland, Ohio, 2000, pp. 12.
- [61] J.G. Schreiber, L.G. Thieme, Overview of NASA GRC Stirling technology development, in: 1st International Energy Conversion Engineering Conference, AIAA, Portsmouth, Virginia, 2003, pp. 9.
- [62] E.J. Wahlquist, E. Mastal, P. Cunningham, A. Farabee, R. Vallee, B. Boore, D.K. Bailey, R. Carpenter, J. Scoriah, R. Dintman, R. Hagen, Radioisotope Facilities Task Force Report: Pu-238 Production and Processing and Heat Source Radioisotope Power System Assembly and Testing, Department of Energy (Ed.), Office of Nuclear Energy, Washington, D.C., 1993, pp. 86.
- [63] M. Dahl, R.W. Campbell, P.T. Lyman, N. Trulock, R.G. Olesch, N. Haberman, W.C. Dennis, Jr., G.A. Kossi, E.G. Tourigny, E.J. Wahlquist, Pu-238 Facilities Review Team Report: Confirmation of Costs To Sustain RTG Production Capability, Department of Energy (Ed.), Washington, D.C., 1996, pp. 35.
- [64] I. Magwood, D. William, Finding of no significant impact—environmental assessment for the future location of heat source/radioisotope power system assembly and test operations currently located at the mound site, in: Department of Energy (Ed.), Office of Nuclear Energy, Science, and Technology, Washington, D.C., 2002, pp. 4.
- [65] I. Magwood, D. William, Amended record of decision for the Department of Energy's final programmatic environmental impact statement for accomplishing expanded civilian nuclear energy research and development and isotope production missions in the United States, including the role of the Fast Flux Test Facility, in: Department of Energy (Ed.), DOE/EIS-0310, Federal Register, U.S. Government Printing Office, Washington, D.C., 2004, pp. 50, 180–181.
- [66] F. Ritz, C.E. Peterson, Multi-Mission Radioisotope Thermoelectric Generator (MMRTG) Program overview, in: Proceedings of the IEEE 2004 Aerospace Conference, 2004, pp. 2950–2957.
- [67] K. Rosenberg, S. Johnson, Assembly and testing of a radioisotope power system for the New Horizons Spacecraft, in: 4th International Energy Conversion Engineering Conference and Exhibit (IECEC), San Diego, California, AIAA 2006-4192, 2006.
- [68] E.H. Thomas, B. Russell, K.S. Robert, K. Steven, O. William, G. Leo, Multi mission radioisotope thermoelectric generator (MMRTG) performance data and application to life modeling, in: 11th International Energy Conversion Engineering Conference, San Jose, California, 2013.
- [69] L. Dudzinski, J. Hamley, J.S. Thomas, J.F. Zakrajsek, W.M. Peter, NASA's Radioisotope Power Systems Program status, in: 11th International Energy Conversion Engineering Conference, San Jose, California, 2013, pp. 10.
- [70] R.M. Wham, Plutonium-238 supply project: a one year summary, in: Nuclear and Emerging Technologies for Space, Albuquerque, New Mexico, 2013, pp. 7.
- [71] C.F. Bolden, Jr., National Aeronautics and Space Administration FY2014 President's Budget Request, in: NASA Administration (Ed.), Washington, D.C., 2013, pp. 657.
- [72] An act making consolidated appropriations for the fiscal year ending September 30, 2014, and for other purposes, One Hundred Thirteenth Congress of the United States of America, Washington, D.C., 2014, pp. 639.
- [73] W.J. Adams, H. Bell, F. Bellinger, T. Frazier, K. Gilligan, R.L. McNutt, Jr., M. Rokey, D. Schurr, DOE Radioisotope Power Systems Infrastructure and Plutonium-238 Production Independent Review, NASA, Washington, D.C., 2013.
- [74] National Aeronautics and Space Administration, Titan Saturn System Mission Study Final Report, NASA Task Order #NMOO710851, NASA, Washington, D.C., 2009.
- [75] W.B. Hubbard, Ice Giants Decadal Mission Study Final Report, NASA SDO-12345, Washington, D.C., June 3, 2010.
- [76] National Aeronautics and Space Administration, Nuclear Power Assessment Mission Studies for Enabling and Extending Future Space Exploration, RPS-RPT-0121 (JPL D-81712), NPAS Mission Study Team, Washington, D.C., 2015.

- [77] National Aeronautics and Space Administration, COMPASS Final Report: Titan Saturn System Mission (TSSM), CD-2014-109, 2014.
- [78] National Aeronautics and Space Administration/Department of Energy Study Team, Small Fission Power System Feasibility Study Final Report, May 13, 2010.
- [79] E.C. Snow, R.W. Zocher, General-Purpose Heat Source Development: Phase I—Design Requirements, Los Alamos Scientific Laboratory, Los Alamos, New Mexico, 1978, pp. 22.
- [80] E.C. Snow, R.W. Zocher, I.M. Grinborg, L.E. Hulbert, General-Purpose Heat Source Development: Phase II—Conceptual Designs, Los Alamos Scientific Laboratory, Los Alamos, New Mexico, 1978, pp. 23.
- [81] T. Hammel, R. Bennett, S. Keyser, R. Sievers, W. Otting, Multi-mission radioisotope thermoelectric generator (MMRTG): proven power for next generation radioisotope power systems, in: 10th International Energy Conversion Engineering Conference, AIAA, Atlanta, Georgia, 2012.
- [82] U.S. Nuclear Regulatory Commission, Certificate Of Compliance for Radioactive Material Packages, NRC Form 618, 2000. <http://rampac.energy.gov/docs/certificates/1019225.PDF>
- [83] U.S. Department of Energy, Supplement Analysis for the Programmatic Environmental Impact Statement (PEIS) for Accomplishing Expanded Civilian Nuclear Energy Research and Development and Isotope Production Missions in the United States, DOE/EIS-0310-SA-01, Washington, D.C., 2004.
- [84] U.S. Department of Energy, Amended Record of Decision for the Department of Energy's Final Programmatic Environmental Impact Statement for Accomplishing Expanded Civilian Nuclear Energy Research and Development and Isotope Production Missions in the United States, Including the Role of the Fast Flux Test Facility, DOE/EIS-0310, Washington, D.C., 2004.
- [85] M. Mirshak, Construction of MOX plant at SRS to continue through September, in: The Augusta Chronicle, Augusta, Georgia, April 29, 2014.
- [86] Mixed Oxide (MOX) Fuel Fabrication Facility, About the MOX Project, CB&I AREVA MOX Services, LLC, Aiken, South Carolina, 2010.
- [87] C.A. Mangeng and G.R. Thayer, Beneficial Uses of Am-241, LA-10075-MS, Los Alamos National Laboratory, Los Alamos, New Mexico, 1984.
- [88] L.W. Gray, et al., Recovery of Americium-241 From Aged Plutonium Metal, DP-1577, Department of Energy, Washington, D.C., 1980.
- [89] V.C.A. Vaughen, et al., The preparation of multigram quantities of Curium-242 for SNAP-11, Nucl. Appl. 6 (1969).
- [90] Department of Energy, Draft Surplus Plutonium Disposition Supplemental Impact Statement, DOE/EIS-0283-S2, Department of Energy, Washington, D.C., 2012. http://energy.gov/sites/prod/files/EIS-0283-Sup_DEIS_Vol1-2012.pdf_0.pdf
- [91] Steven R. Oleson, et al., COMPASS Final Report: Kuiper Belt Object Orbiter (KBOO), NASA Glenn CD-2009-32 (2009).
- [92] W.A. Wong, Advanced Radioisotope Power Conversion Technology Research and Development, NASA/TM-2004-213352, NASA Glenn Research Center, Cleveland, Ohio, 2004.
- [93] L.S. Mason, Realistic specific power expectations for advanced radioisotope power systems, Journal of Propulsion and Power 23 (2007) 1075-1079.
- [94] J.J. Breedlove, T.M. Conboy, D. Deserranno, M.V. Zagarola, Turbo-Brayton power converter for spaceflight applications, in: Proceedings of the 2015 Nuclear and Emerging Technologies in Space (NETS 2015), 2015, Albuquerque, New Mexico, to be published.
- [95] T. Caillat, et al., Progress status of the development of high-efficiency segmented thermoelectric couples, in: Proceedings of 11th International Energy Conversion Engineering Conference, San Jose, California, 2013.

- [96] T. Sutliff, L. Dudzinski, NASA Radioisotope Power System Program—Technology and Flight Systems, in: 7th International Energy Conversion Engineering Conference, Denver, Colorado, AIAA-2009-4575, 2009.
- [97] Bennett, E.A. Skrabek, Power performance of U.S. radioisotope thermoelectric generators, in: Proceedings of Fifteenth International Conference on Thermoelectrics, Pasadena, California, 1996, pp. 357–372.
- [98] D. Woerner, et al., Getting to an enhanced MMRTG, in: Proceedings of the Nuclear and Emerging Technologies for Space (NETS) Conference, NASA Stennis Space Center, Mississippi, 2014.
- [99] J.G. Schreiber, Developmental Considerations on the Free-Piston Stirling Power Converter for Use in Space, NASA/TM—2007-214805, AIAA-2006-4015, NASA Glenn Research Center, Cleveland, Ohio, 2007.
- [100] J.G. Schreiber, L.G. Thieme, Final Results for the GRC Supporting Technology Development Project for the 110-Watt Stirling Radioisotope Generator (SRG110), NASA/TM—2007-214839, NASA Glenn Research Center, Cleveland, Ohio, 2007.
- [101] J. Chan, G. Wood, J. Schreiber, Development of Advanced Stirling Radioisotope Generator for Space Exploration, NASA/TM—2007-214806, NASA Glenn Research Center, Cleveland, Ohio, 2007.
- [102] B. Otting, T. Hammel, D. Woerner, J.-P. Fleurial, Advanced radioisotope thermoelectric generator (ARTG) design options leveraging segmented thermoelectric technology development, in: Proceedings of the 2015 Nuclear and Emerging Technologies in Space (NETS 2015), Albuquerque, New Mexico, 2015, to be published.
- [103] B.A. Harmon, D.B. Lavery, NASA Radioisotope Power Systems Program update, AIP Conference Proceedings 969 (2008) 396-402.
- [104] R. Ewell, T. Caillat, Development status and plans of the Advanced Thermoelectric Converter (ATEC) project, in: Space Technology and Applications Forum, Albuquerque, New Mexico, 2008.
- [105] D.J. Anderson, J. Sankovic, D. Wilt, R.D. Abelson, J.P. Fleurial, NASA's Advanced Radioisotope Power Conversion Technology Development Status, NASA/TM—2007-214487, IEEEAC Paper 1610, NASA Glenn Research Center, Cleveland, Ohio, 2007.
- [106] J.-P. Fleurial, C. Jordan, G. Pawan, S. Firdosy, B.C. Li, N.R. Keyawa, G.H. Nakatsukasa, B. Nesmith, 1 kW small fission heat pipe-cooled thermoelectric power system design concept and technology maturation, in: 11th International Energy Conversion Engineering Conference, San Jose, California, 2013.
- [107] M.L. Olsen, et al., A high-temperature, high-efficiency solar thermoelectric generator prototype, Energy Procedia. 49 (2014) 1460–1469.
- [108] S. Krishnan, T.J. Hendricks, N.K. Karri, P.K. Gogna, J.R. Chase, J.-P. Fleurial, Progress towards an optimization methodology for combustion-driven portable thermoelectric power generation systems, JOM 41 (2012) 1622–1631.
- [109] E.J. Lewandowski, Testing of the Advanced Stirling Radioisotope Generator Engineering Unit at NASA Glenn Research Center, NASA/TM—2013-217854, AIAA-2012-4253, NASA Glenn Research Center, Cleveland, Ohio, 2013.
- [110] E.J. Lewandowski, G.S. Bolotin, S.M. Oriti, Test program for Stirling radioisotope generator hardware at NASA Glenn Research Center, in: Proceedings of the 12th International Energy Conversion Engineering Conference, Cleveland, Ohio, AIAA 2014-3964, 2014.
- [111] W.A. Wong, S. Wilson, J. Collins, Advanced Stirling Converter (ASC) development for NASA RPS, in: Proceedings of the 12th International Energy Conversion Engineering Conference, Cleveland, Ohio, AIAA 2014-3962, 2014.
- [112] J. Stanley, J.G. Wood, E. Holliday, S.M. Geng, Progress in the development of a 12 kW_e Stirling power conversion unit for fission power systems, in: Proceedings of Nuclear and Emerging Technologies for Space 2013, Albuquerque, New Mexico, NETS Paper 6753, 2013.
- [113] N.A. Schifer, S.M. Oriti, Summary of Stirling Converter Testing at NASA Glenn Research Center in Support of Stirling Radioisotope Power System Development, NASA/TM—2013-216543, NETS-2013-6816, NASA Glenn Research Center, Cleveland, Ohio, 2013.

- [114] C. Schwendeman, C. Tarau, W.G. Anderson, P.A. Cornell, Alkali metal backup cooling for Stirling systems—experimental results, in: Proceedings of Nuclear and Emerging Technologies for Space 2013, Paper 6733, Albuquerque, New Mexico, 2013.
- [115] P.C. Schmitz, Parametric system model for a Stirling radioisotope generator, in: Proceedings of the 12th International Energy Conversion Engineering Conference, Cleveland, Ohio, AIAA 2014–3461, 2014.
- [116] G. Brown, J. Wisner, M. Coe, J. Chan, Scalable Controller Concepts for High Power Nuclear Stirling Systems, IAC-14-C3.5-C4.7.10x26290, International Astronautical Congress, Toronto, 2014.
- [117] National Aeronautics and Space Administration, Advanced Stirling Converter ASC Controller Unit ACU Testing and Fabrication, Contract No. NNC14CA03C, Report No. AACU–RP–14–0109, NASA Glenn Research Center, Cleveland, Ohio, 2014.
- [118] L. Mason, et al., A Small Fission Power System With Stirling Power Conversion for NASA Science Missions, NASA/TM–2011-217204, NASA Glenn Research Center, Cleveland, Ohio, 2011.
- [119] D.I. Poston, D.D. Dixon, P.R. McClure, M.A. Gibson, A simple, low-power fission reactor for space exploration power systems, in: Proceedings of 2013 Nuclear and Emerging Technologies in Space (NETS 2013), Albuquerque, New Mexico, 2013.
- [120] D.I. Poston, P.R. McClure, D.D. Dixon, M.A. Gibson, L. Mason, Experimental demonstration of a heat pipe—Stirling engine nuclear reactor, Nuclear Technology 188 (2014) 229–237.
- [121] P.R. McClure, D.I. Poston, M. Gibson, C. Bowman, J. Creasy, KiloPower Space Reactor Concept—Reactor Materials Study, LA–UR–14–23402, Los Alamos National Laboratory, Los Alamos, New Mexico, 2014.
- [122] M.A. Rucker, Integrated surface power strategy for Mars, in: Proceedings of the 2015 Nuclear and Emerging Technologies in Space (NETS 2015), Albuquerque, New Mexico, 2015, to be published.
- [123] M.A. Gibson, L. Mason, C. Bowman, D.I. Poston, P.R. McClure, J. Creasy, C. Robinson, Development of NASA's small fission power system for science and human exploration, in: Proceedings of the 12th International Energy Conversion Engineering Conference, Cleveland, Ohio, AIAA 2014–3458, 2014.
- [124] U.S. Department of Energy, Space and Defense Power Systems Ten-Year Strategic Plan, INL/MIS–13–29522, Vol. 1, Idaho National Laboratory, Idaho Falls, Idaho, 2013.
- [125] U.S. Department of Energy, Space and Defense Power Systems Ten-Year Strategic Plan, INL/MIS–13–29522, Vol. 2, Idaho National Laboratory, Idaho Falls, Idaho, 2013.
- [126] G.L. Bennett, Flight safety review process for space nuclear power sources, in: Transactions 22nd Intersociety Energy Conversion Engineering Conference, Philadelphia, Pennsylvania, 1987.
- [127] J.A. Sholtis, Jr., R.O. Winchester, N.W. Brown, L.W. Connell, A.C. Marshall, W.H. McCulloch, J.E. Mims, and A. Potter, U.S. space nuclear safety: past, present, and future, in: A Critical Review of Space Nuclear Power and Propulsion 1984–1993, American Institute of Physics Publishing, New York, 1994, pp. 269–303.
- [128] J.A. Sholtis, Jr., Nuclear Space Power Systems: Ensuring Safety From Beginning to End, in: Space Power 8 (1989) 406–407.
- [129] A.C. Marshall, et al., Space Nuclear Safety, ISBN–13: 978–0–89464–061–2 and ISBN–10: 0–89464–061–5, Krieger Publishing Company, Malabar, Florida, 2008.
- [130] S.S. Voss, SNAP Reactor Overview, AFWL–TN–84–14, Air Force Weapons Laboratory, Kirtland, Air Force Base, New Mexico, 1984.
- [131] R.S. Hart, and W.T. Harper (Eds.), Final SNAPSHOT Safeguards Report, North American Aviation Report NAA–SR–10022 (Rev.), Canoga Park, California, 1965.

- [132] Department of Energy, Atomic Power in Space—A History, DOE/NE/32117–H1, Prepared by Planning & Human Systems, Inc., Washington, D.C. under DOE Contract DE–AC01–NE32117, for U.S. Department of Energy, Assistant Secretary for Nuclear Energy, Deputy Assistant Secretary for Reactor Systems Development & Technology, Washington, D.C., 1987.
- [133] Atomic Energy Commission, Announcement No. E–69: Aerospace Nuclear Safety Conference, Atomic Energy Commission, Washington, D.C., 1960.
- [134] Atomic Energy Commission, Aerospace Nuclear Safety, Memorandum for AEC Chairman McCone, prepared by Director, Division of Reactor Development, Atomic Energy Commission, Washington, D.C., 1960.
- [135] J.A. Connor, Jr., Safety Aspects of the Nuclear Space Program, remarks by Lt. Col. Joseph A. Connor, Jr., before the Annual Conference of the Atomic Industrial Forum, San Francisco, California; Atomic Energy Commission (AEC) Press Release December 15, 1960, Washington, D.C., 1960.
- [136] H.M. Dieckamp, Nuclear Space Power Systems, Atomics International, North American Aviation, Inc., Canoga Park, California, 1967.
- [137] Department of Energy, SP–100 space reactor safety, in: SP–100 Program Brochure, DOE/NE–0083, U.S. Department of Energy, Washington, D.C., 1987.
- [138] D.H. Kristensen, Safety Strategy for the Space Nuclear Thermal Propulsion (SNTP) Program, USAF Nuclear Surety Journal, U.S. Air Force Publication 122–1, No. 92–02, Volume 11, No. 2, Air Force Safety Agency, Kirtland Air Force Base, New Mexico, 1992, pp. 18–19.
- [139] BMDO and USAF, NEPSTP Nuclear Safety Policy, Functional Requirements and Safety Guidelines, Nuclear Electric Propulsion Space Test Program Document NEPSTP/T–002, Ballistic Missile Defense Organization and U.S. Air Force Phillips Laboratory, Kirtland Air Force Base, New Mexico, 1993.
- [140] A.C. Marshall, R.A. Bari, N.W. Brown, H.S. Cullingford, A.C. Hardy, J.H. Lee, W.H. McCulloch, K. Remp, G.F. Niederauer, J.W. Rice, J.C. Sawyer, and J.A. Sholtis, Jr., Nuclear Safety Policy Working Group (NSPWG) Recommendations on Nuclear Propulsion Safety for the Space Exploration Initiative (SEI), NASA TM–105705, Washington, D.C., 1993.
- [141] R.D. Bechtel, R.J. Lipinski, A. Smith, et al., The United States approach to risk assessment and its role in implementing an effective safety programme for nuclear power source applications in outer space, in: United Nations Committee on Peaceful Uses of Outer Space, A/AC.105/C.1/L.312, Vienna, Austria, 2011.
- [142] UNCOPUOS and IAEA, Safety framework for nuclear power source applications in outer space, in: the United Nations Committee on the Peaceful Uses of Outer Space (UNCOPUOS), Scientific and Technical Subcommittee, and the International Atomic Energy Agency (IAEA), A/AC.105/934, Vienna, Austria, 2009.
- [143] National Environmental Policy Act, NEPA 14 CFR Part 1216 and 40 CFR Parts 1500–1508, U.S. Environmental Protection Agency, Washington, D.C., 1969.
- [144] Presidential Directive/National Security Council, Scientific or technical experiments with possible large-scale adverse environmental effects and launch of nuclear systems into space, in: White House Office of Science Technology Policy, PD/NSC Memorandum 25, December 14, 1977, and as amended, May 18, 1996.
- [145] Department of Energy, Nuclear Safety Criteria and Specifications for Space Nuclear Reactors, U.S. Department of Energy, Office of Space Nuclear Projects, Report OSNP–1, Rev 0, Washington, D.C., 1982.
- [146] L.W. Connell, L.C. Trost, Reentry safety for the Topaz II space reactor: issues and analyses, in: document prepared by Sandia National Laboratories for the United States Department of Energy under Contract DE–AC04–94AL85000, SAND94–0484, 1994.
- [147] J.A. Sholtis, Jr., Proposed safety guidelines for space reactors, in: Proceedings of the ANS Embedded Topical Meeting, Space Nuclear Conference 2005, San Diego, California, ISBN: 0–89448–696–9, 2005.
- [148] National Aeronautics and Space Administration, NASA National Environmental Policy Act Management Requirements, NASA Procedural Requirements 8580.1A, NASA, Washington, D.C., 2012.

- [149] National Aeronautics and Space Administration, NASA General Safety Program Requirements, in: Nuclear Safety for Launching of Radioactive Materials, NASA Procedural Requirements 8715.3C, Chapter 6, NASA Office of Safety and Mission Assurance, Washington, D.C., amended February 8, 2013.
- [150] R. Wilcox, Safety in the Design and Development of United States Nuclear Power Source Applications in Outer Space, in: United Nations Committee on Peaceful Uses of Outer Space, A/AC.105/C.1/L.313, United Nations, Washington, D.C., 2011.
- [151] R.J. Lipinski, et al., Launch safety analysis for radioisotope power systems, in: Institute of Nuclear Materials Management 55th Annual Meeting, Sec. 3.2., INM, Atlanta, Georgia, 2014.
- [152] U.S. Department of Energy, Safeguards and Security Program, DOE Order 470.4, Washington, D.C., 2011.
- [153] U.S. Department of Energy, Graded Security Protection, DOE Order 470.3B, Washington, D.C., 2008.
- [154] U.S. Department of Energy, Protection Program Operations, DOE Order 473.3, Washington, D.C., 2011.
- [155] U.S. Department of Energy, Nuclear Material Control and Accountability, DOE Order 474.2, Washington, D.C., 2011.
- [156] E.F. Wilson, Software evolution in practice for the U.S. Department of Energy experience report, in: IEEE International Conference on Software Maintenance, Victoria, BC, 1994, pp. 434–436.
http://ieeexplore.ieee.org/xpl/freeabs_all.jsp?arnumber=336751&abstractAccess=no&userType=inst
- [157] Lenel Systems International, Inc., Communication server cryptographic module security policy, in:
<http://csrc.nist.gov/groups/STM/cmvp/documents/140-1/140sp/140sp1683.pdf>
- [158] U.S. Department of Energy, Design Basis Threat Policy, DOE Order 470.3A, Washington, D.C., 2005.
- [159] National Aeronautics and Space Administration, Radioisotope Power Systems Program Requirements Document, NASA Glenn Research Center, Cleveland, Ohio, 2013.
- [160] G. English, R. Cook, R. Langevin, S. Johnson, National Aeronautics and Space Administration John F. Kennedy Space Center, Future fission power system security gap analysis, protection recommendations and cost estimates, Idaho National Laboratory, Idaho Falls, Idaho, 2014, pp. 46.
- [161] R.E. Tate, The Light Weight Radioisotope Heater Unit (LWRHU): A technical description of the reference design, in: J. Warren (Ed.), Los Alamos National Laboratory, Los Alamos, New Mexico, 1982, pp. 40.
- [162] P.C. Schmitz, L.B. Penswick, R.K. Shaltens, Lunar surface Stirling power systems using isotope heat sources, in: 7th International Energy Conversion Engineering Conference, Denver, Colorado, AIAA–2009–4578, 2009, pp. 30.
- [163] L. Summerer, K. Stephenson, Nuclear power sources: a key enabling technology for planetary exploration, in: Proceedings of the Institution of Mechanical Engineers, Part G: Journal of Aerospace Engineering, 225 (2011) 129–143.
- [164] G.R. Ford, Statement on nuclear policy, in: Gerhard Peters and John T. Woolley (Eds.), The American Presidency Project, 1976. <http://www.presidency.ucsb.edu/ws/?pid=6561>
- [165] A.S. Mehner, Alternative fuel considerations (enclosure to letter to Ronald F. Draper), in: S.a.D.P. Systems (Ed.), Department of Energy, Washington, D.C., 1989, pp. 6.
- [166] G.R. Dochat, M. Dhar, Free piston space Stirling technology program, in: Proceedings of the 24th Intersociety Energy Conversion Engineering Conference, Washington, D.C., vol. 842, 1989, pp. 849–854.
- [167] S. Wilson, S. Orti, Advanced Stirling Converter Testing Overview at NASA Glenn Research Center, in: 8th Annual International Energy Conversion Engineering Conference, Nashville, Tennessee, 2010.
- [168] S. Wilson, W.A. Wong, NASA GRC support of the flight ASRG Project, in: 12th International Energy Conversion Engineering Conference, Cleveland, Ohio, 2014.
- [169] A.W. Fihelly, H.N. Berkow, C.F. Baxter, SNAP–19/Nimbus B integration experience, International Energy Conversion Engineering Conference '68, Boulder, Colorado, 1968, pp. 34.

- [170] National Aeronautics and Space Administration, Nimbus Program History, Goddard Space Flight Center, Greenbelt, Maryland, 2004, pp. 34.
- [171] A.W. Fihelly, C.F. Baxter, The SNAP-19 Radioisotopic Thermoelectric Generator Experiment, IEEE Transactions on Geoscience Electronics 8 (1970) 255–264.
- [172] A.W. Fihelly, C.F. Baxter, W.C. Lyon, Orbital performance of the SNAP-19 radioisotope fueled thermoelectric power supply, in: AIAA 3rd Communications Satellite Systems Conference, Los Angeles, California, 1970, pp. 9.
- [173] D. Buden, Summary of space nuclear reactor power systems, in: Symposium on Space Nuclear Power and Propulsion, Department of Energy, Albuquerque, New Mexico, 1993, pp. 69.
- [174] A.C. Marshall, E.F. Haskin, V. Usov, Space Nuclear Safety, Krieger Publishing Company, Malabar, Florida, 2008, pp. xix and 463.
- [175] A.E. Dwight, The uranium-molybdenum equilibrium diagram below 900° C, Journal of Nuclear Materials 2 (1960) 81–87.
- [176] S.P. Garg, R.J. Ackermann, The high temperature phase diagrams for Th-Mo, Th-Re, U-Mo, and U-Re; derived thermodynamic properties of refractory metal solutes in liquid thorium and uranium, Journal of Nuclear Materials 64 (1977) 265–274.
- [177] G. Beghi, Gamma phase uranium-molybdenum fuel alloys, in: Other Information: UNCL. Orig. Receipt Date: 31-DEC-69, 1968.
- [178] V.D. Dmitriev, S.S. Ibragimov, A.G. Karmilov, Effects of neutron irradiation on the structure and properties of uranium alloys containing 0.6–9% by weight molybdenum, Energy 22 (1967) 574–579.
- [179] F.B.V.d. Oliveira, D.A.d. Andrade, Stability of γ -UMo Nuclear Fuel Alloys by Thermal Analysis, 2013.
- [180] J.H. Kittel, T.K. Bierlein, B.R. Hayward, W.C. Thurber, Irradiation behavior of metallic fuels, in: Third International Conference on the Peaceful Uses of Atomic Energy, United Nations, Geneva, Switzerland, 1964, pp. 227–234.
- [181] J.H. Kittel, B.R.T. Frost, J.P. Mustelier, K.Q. Bagley, G.C. Crittenden, J. Van Dievoet, History of fast reactor fuel development, Journal of Nuclear Materials 204 (1993) 1–13.
- [182] R.S. Barnes, R.G. Bellamy, B.R. Butcher, P.G. Mardon, The irradiation behavior of uranium alloy and uranium alloy fuels, in: Third International Conference on the Peaceful Uses of Atomic Energy, United Nations, Geneva, Switzerland, 1964, pp. 218–224.
- [183] B.R. Butcher, B.A. Hatt, The mechanical properties of quenched uranium-molybdenum alloys: part II: a preliminary survey of the deformation mechanisms, Journal of Nuclear Materials 11 (1964) 163–182.
- [184] R.F. Hills, B.R. Butcher, B.W. Howlett, The mechanical properties of quenched uranium-molybdenum alloys: part I: tensile tests on polycrystalline specimens, Journal of Nuclear Materials 11 (1964) 149–162.
- [185] M.P. Johnson, W.A. Holland, Irradiation of U-Mo Base Alloys, Atomics International, Canoga Park, California, 1964.
- [186] H.H. Chiswick, A.E. Dwight, L.T. Lloyd, M.V. Nevitt, S.T. Zegler, Advances in the physical metallurgy of uranium and its alloys, in: Second United Nations International Conference on the Peaceful Uses of Atomic Energy, United Nations, Geneva, Switzerland, 1958, pp. 394–411.
- [187] M.K. Meyer, J. Gan, J.F. Jue, D.D. Keiser, E. Perez, A. Robinson, D.M. Wachs, N. Woolstenhulme, G.L. Hofman, Y.S. Kim, Irradiation performance of U-Mo monolithic fuel, Nuclear Engineering and Technology 46 (2014) 169–182.
- [188] A.L. Lotts, Review and information on U-Mo alloys and U-Mo-UO₂ dispersion fuels, 1960.
- [189] C. Wiedemann, M. Oswald, S. Stabroth, H. Klinkrad, P. Vörsmann, Modeling of RORSAT NaK droplets for the MASTER 2005 upgrade, Acta Astronautica 57 (2005) 478–489.
- [190] J.R. Powell, G. Maise, J. Paniagua, S. Borowski, MITEE-B: A compact lightweight bi-modal nuclear engine to deliver both high propulsive thrust and high electric power, 2001.

- [191] L. Mason, M. Gibson, D. Poston, Kilowatt-class fission power systems for science and human precursor missions, in: *Nuclear and Emerging Technologies for Space 2013*, Albuquerque, New Mexico, 2013, pp. 7.
- [192] B. Richardson, Record of Decision for the Programmatic Environmental Impact Statement for Accomplishing Expanded Civilian Nuclear Energy Research and Development and Isotope Production Missions in the United States, Including the Role of the Fast Flux Test Facility, in: Department of Energy (Ed.), *Federal Register*, U.S. Government Printing Office, Washington, D.C., 2001, pp. 7877–7887.
- [193] Department of Energy, Supplement Analysis for the Nuclear Infrastructure Programmatic Environmental Impact Statement for Plutonium-238 Production for Radioisotope Power Systems, Department of Energy, Washington, D.C., 2013, pp. 64.
- [194] D.I. Poston, R.J. Kapernick, R.M. Guffee, R.S. Reid, R.J. Lipinski, S.A. Wright, R.A. Talandis, Design of a heatpipe-cooled Mars-surface fission reactor, *AIP Conference Proceedings* 608 (2002) 1096–1106.
- [195] R.J. Lipinski, S.A. Wright, M.P. Sherman, R.X. Lenard, R.A. Talandis, D.I. Poston, R. Kapernick, R. Guffee, R. Reid, J. Elson, J. Lee, Small fission power systems for Mars, *AIP Conference Proceedings* 608 (2002) 1043–1053.
- [196] S.A. Wright, D. Poston, Low mass radiation shielding for Martian surface power reactors, *AIP Conference Proceedings* 608 (2002) 759–767.
- [197] J.O. Elliott, R.J. Lipinski, D.I. Poston, Design Concept for a Nuclear Reactor-Powered Mars Rover, *AIP Conference Proceedings* 654 (2003) 376–383.
- [198] L. Mason, Realistic Specific Power Expectations for Advanced Radioisotope Power Systems, in: *4th International Energy Conversion Engineering Conference and Exhibit (IECEC)*, San Diego, California, AIAA 2006–4193, 2006.