

# Kennedy Space Center Technology Transfer News

Dr. Tracy Gibson and  
Dr. Mark Nurge

Photo credit:  
Kevin O'Connell/ASRC

## Hetal Miranda

### Manager of the KSC Technology Transfer (T2) Program

Hetal Miranda, the new manager of the KSC Technology Transfer (T2) Program, brings over 11 years of experience from both the private industry and her roles as a contractor and civil servant for NASA. Her passion for the space program inspired her to obtain a B.S. in Aerospace Engineering from the University of Central Florida (UCF), with the hope of one day working for NASA. After completing her bachelor's degree, she continued to further her education by completing an M.S. in Industrial Engineering from UCF.

When asked about her education background and why she chose her fields of study, Hetal responded that she chose engineering because “[she has] always been fascinated not just by how things work, but also by the larger systems and interconnectivity that govern them.” Her proficiency in industrial engineering has allowed her to analyze complex systems and determine the best ways to improve efficiency, performance, and productivity, and these skills have been instrumental in her success at NASA.

Hetal's first experience at KSC was as an intern, where she worked on a variety of projects with the Technology Transfer Program office. After graduating, she worked as a NASA contractor contributing her expertise in mechanical systems design of ground support equipment for the Constellation program. When the program was coming to an end, she then returned to the Technology Transfer office, where she undertook various responsibilities including leading technology integration and partnership development initiatives. Before starting her current role as manager of the T2 Program, she spent some time working for a small space technology start-up, which allowed her to experience firsthand how a company can leverage NASA technology to create innovative solutions and products for the commercial space industry.

In her current role as the manager of the T2 Program, Hetal is responsible for ensuring that the innovations in space exploration developed at KSC are made available to the public. A key facet of this responsibility involves identifying and cultivating new partnerships and opportunities for collaboration that will expand the reach and impact of technology transfer initiatives. As manager, Hetal is an “advocate of the technology transfer team, supporting their efforts, and creating an environment where they can continue to innovate and succeed.” She is dedicated to fostering a culture of collaboration and innovation within the team while also developing relationships both within NASA and externally to maximize the impact of the team's technology transfer efforts.

When asked about some of the projects she has worked on during her time with NASA, Hetal mentioned that one of the most rewarding projects she led



was a pilot innovation accelerator initiative that established a framework for fostering a culture of innovation at KSC. The initiative provided a collaborative, supportive environment where innovators could flourish, and “was a testament to the value of investing in people and creating a culture of innovation that can drive progress and change.”

Another project Hetal led in her time at NASA, was the management of an agency-level initiative for the Capabilities Integration Team in the Exploration Systems Development Mission Directorate (ESDMD). The goal of this project was to release an agency-wide data call to assess the technical facility capabilities that would be needed over the next 5-10 years that would enable closure of the ESDMD Exploration Capability Gaps (HEOMD-405) and meet the architecture mission needs. Hetal enjoyed this project as it allowed her to collaborate with the technical community, utilizing her technical and communication skills, and “make a meaningful contribution to the future of NASA's exploration and technology capabilities.”

In her spare time, Hetal loves to spend quality time with her family, reading science fiction, listening to a variety of podcasts, and running. She is “proud to be a part of NASA, and excited to continue pushing the boundaries of what's possible in space exploration.”

## KSC T2 Team

*Jim Nicols,  
Delvin Vannorman,  
Meredith Reeves,  
Hetal Miranda,  
Megan Victor,  
Jeff Kohler,  
Lewis Parrish*



# Capacitive Mass Gauging Technology

## A NASA Early Career Initiative

Chris Biagi, of the Applied Physics Lab, has been with NASA for three years. Prior to joining NASA, he worked in both academia and industry, and gained experience in investigating new capacitance technologies. Dr. Biagi received a BS in physics (2003) and an MS in atmospheric sciences (2006) from the University of Arizona and continued on to earn an MS and a PhD in electrical and computer engineering from the University of Florida in 2008 and 2011, respectively.

Within the APL, Dr. Biagi is heading the development of a new technology called Capacitive Mass Gauging (CAPMAG). Currently, there is no easy way to determine the amount of liquid in a tank in space, since the microgravity environment allows the liquid to float in the container and accumulate on the container walls. This is problematic, as the propellants used for space exploration are in liquid form, so a safe, reliable way to measure the amount remaining in a container is needed.

CAPMAG is a capacitance technology that would allow for the determination of the amount of fluid in a tank. It is particularly suitable

for cryogenic fluids, in part because the measurement does not deposit any energy into the fluid (i.e., the measurement does not cause the fluid to heat up). Additionally, CAPMAG doesn't require any moving parts, making it easy to incorporate into space flight technologies.

The development of CAPMAG is funded by the Early Career Initiative (ECI), which gives early career scientists at NASA the opportunity to work on innovative projects and collaborate with a variety of internal and external partners. For Dr. Biagi, the ECI has been a “fantastically transformative experience,” as it has allowed him and his team members to grow, gain experience with the research process at NASA, and meet a number of the supportive, talented people that work for and with NASA across the country.



# KSC Labs Collaborate on Technology Development

## From Gas and Fluid Sensors to an Advanced Thermal Control Coating

*Robert Cox,  
Chris Biagi,  
Madeleine DeFilippo,  
Austin Atkins,  
Carolina Franco,  
Tracy Gibson,  
Annelisa Esparza,  
Nicholas Spangler,  
Joel Olson*

*Not present:  
Mark Nurge and  
Kenneth Engeling.*



At the Kennedy Space Center (KSC), scientists in the Applied Physics Lab (APL) and Applied Chemistry Lab (ACL) collaborate on many different projects. Each lab brings their own expertise and experience to a project, creating an interdisciplinary team that can use their varied experience to develop innovative solutions and technologies. Conveniently, the labs are located in the same building, making it easy to work together when needed.

Mark Nurge is the current lead scientist of the APL, which was founded in the 1990s. He has been with NASA for 36 years and has published several patents and over 25 journal articles and technical memoranda during this time. He was selected as Kennedy Space Center's Engineer/Scientist of the year in 2014 and has also been a Launch Honoree.

A chemist in the ACL, Tracy Gibson, has worked at KSC for 20 years. During his time at KSC he has published 15 patents, and has been an innovator on over 90 NASA New Technology Reports. Dr. Gibson has also received many awards while working at NASA, including the NASA Exception Public Service Medal in 2010 and the NASA Silver Achievement Medal in 2014.

The APL is an instrument development lab with research capabilities. It is multidisciplinary, with expertise in fields such as optics, electromagnetics, thermodynamics, electronics and software design, and physics modeling. The lab previously supported the shuttle program and mainly developed one-of-a-kind instruments to solve shuttle problems; however, since the end of the shuttle program the focus has shifted to other research and development projects such as radiation shielding, solar reflective coatings, and electromagnetic effects.

The ACL, on the other hand, is focused on research and technology development, and creates engineering solutions for the ground- and space-based needs of NASA and its external partners. The lab designs and develops technologies at all Technology Readiness Levels (TRLs), and several of these technologies have been commercialized. Current research focuses in the ACL include hypergol detection capabilities, in-situ resource utilization, plasma chemistry, and water treatment and oxygen production.

Over the last several decades the ACL and APL have collaborated on projects ranging from the in-situ resource utilization project Regolith and Environment Science and Oxygen and Lunar Volatiles Extraction (RESOLVE) to a project looking at methods to dry Space Shuttle tiles to a project analyzing the dielectric properties of spaceflight materials. More recently, the two laboratories have collaborated on projects related to sensor development and evaluation and novel materials for cryogenic fluid management. Several of these more recent projects will be discussed in further detail.

One collaborative project between the two labs is the testing of hydrogen and methane sensors. Liquid hydrogen (LH2) is used as fuel for rocket propulsion systems but can be dangerous because it is extremely flammable. Therefore, early and accurate detection of any LH2 leaks is necessary for safety reasons. Similarly, the ability to detect methane leaks is also important, due to safety concerns for both personnel and the environment. Commercially available hydrogen and methane sensors were tested by the ACL to evaluate whether they met the requirements to be used at KSC. Various characteristics were tested for each sensor, and it was determined that at least one hydrogen sensor

had the potential to meet KSC requirements, while several of the methane sensors showed quick response times and good repeatability.

Another ongoing project is the development of a sensor to determine the concentration of pre-treat in the Universal Waste Management System (UWMS) on the International Space Station (ISS). Pre-treat is added to the system to process the urine and is highly acidic. It is important that the concentration of pre-treat remain in a specified range, as if it is too high it can lead to corrosion in the system, and if it is too low it will not properly stabilize the urine. The existing conductivity-based sensor was not functioning properly, so a new optical sensor was considered as a solution to the problem. Scientists in the ACL and APL first completed a feasibility study to determine that an optical sensor could be used, and then designed a system where the pre-treat could be monitored through the walls of PFA tubing in the UWMS based on absorbance measurements. This new design simplifies the sensor and removes the need for optical windows, which reduces the chance of leaks in the system. Although successful measurements were taken with the new optical sensor in a static mixture of water and pre-treat, further testing is required to achieve reliable measurements in a flow system.

In addition to the previously mentioned projects, one major collaboration between APL and ACL was the development and testing of the Solar White material. Solar White is a thermal control coating designed to reflect the majority of the sun's light while also emitting infrared radiation to create a cooling effect. Development of the technology began in the APL, where theory and modeling work was completed to select materials that could potentially be used for the scattering layer. Once the modeling was completed, the materials expertise of ACL was utilized to test and further develop the technology. Both tile samples and a spray-on coating of Solar White have been tested, with the best tile achieving ~1% solar absorptivity and the best spray-on achieving ~4%, allowing for cryogenic temperatures to be maintained at distances of 1 AU from the sun.

Solar White is also being evaluated for use in other applications such as passively cooled superconductors. The cooling effect created by Solar White may allow for high temperature superconductors (HTS) to remain in a superconducting state without the need for liquid nitrogen (LN2) cooling. If LN2 cooling is not needed, it becomes more practical to use HTS for space applications such as magnetic shielding and efficient energy management. Funding was recently received by APL and ACL to investigate if it is possible to passively cool HTS materials with Solar White, and at what distances from the sun the cooling is effective. Testing was conducted in the Cryogenic Test Lab at KSC, and bismuth strontium calcium copper oxide (BSCCO) was chosen as the HTS material since it is often used to make superconducting wires. The BSCCO sample was placed inside a cast aluminum sphere, which was then coated with multiple layers of the spray-on Solar White coating. Initial testing showed that an absorptivity of ~5.25% was achieved with this configuration.

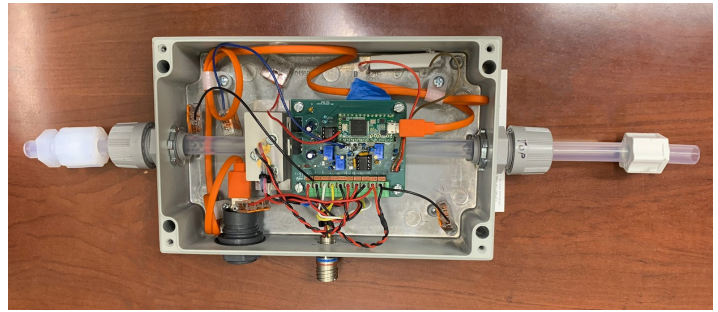

*Optical Concentration Sensor*

It was also determined that, in order to maintain the superconducting state, the temperature of the BSCCO needs to be below 104 K. To achieve this temperature, an absorptivity of ~2.5% is needed. Additional testing is planned to further develop this technology, but Dr. Nurge and Dr. Gibson are optimistic that the tile version of Solar White, and potentially the spray-on as well, will be able to achieve this goal.

Solar White has the potential to be used in many different applications, and three patents have already been issued for the technology. Additionally, several companies have contacted the Tech Transfer office and expressed interest in producing and testing the material, which could lead to the further development and commercialization of the technology.

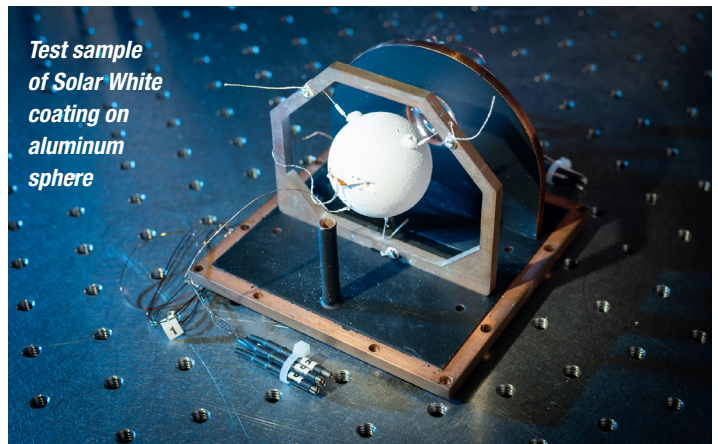

ACL and APL plan to continue their successful collaboration, and work on new projects together in the future. They have recently received funding to develop methods that can reliably generate and quantify hydrazine concentrations of 10 ppb or less. Currently, hydrazine sensors are used in both the ACL and the Components Refurbishment & Chemical Analysis Facility (CRCA), but they are not able to reliably quantify vapor streams at 10 ppb or less. The team plans to develop and modernize the hydrazine generation and quantification processes, develop a new coulometer for the sensor as well as software for data acquisition and analysis, and add vapor dilution hardware to the system to reliably generate 10 ppb levels of hydrazine. Once the new system is shown to be accurate and reliable, it will likely be of interest to other government agencies and industries that utilize hydrazine as well.

# NASA's Low Separation Force Quick Disconnect

## A Self-Aligning, Self-Healing System for Pneumatics and Cryogenics

Umbilicals use fluid connectors, known as quick disconnects (QDs), to transfer fluids into a vehicle. The QDs allow for fast and easy connection and disconnection of fluid lines. Generally, the fluid in a QD follows an axial flow path, which can lead to a high separation force when the system is pressurized since the separation force is proportional to the line pressure. Specifically, the separation force is equal to the fluid pressure times the flow area, and can reach thousands of pounds in some systems. Separation forces of this magnitude require large, heavy support structures, such as umbilical plates and latching mechanisms, to keep the QDs connected.

To eliminate the separation force, the LFD uses a radial flow path rather than axial at the quick disconnect interface. This re-routes the fluid to flow into the connected line perpendicular to the typical flow path in a QD, and allows the fluid to flow evenly around the circumference of the line to balance the pressure. The LFD design also includes ten holes placed around the internal seal, which cancels the load due to the balanced pressure. Because of this innovative design, the separation force is reacted by the internal structure, rather than transferred to the external mounting fixtures and supports as in a traditional QD.



The innovative design and radial flow path of the LFD ensure a low separation force for the device, regardless of line pressure. Since less force is exerted on the fixtures and supports, the overall support structure for the umbilical operations can be lighter and lower strength. This reduces the reliance on high strength locking devices, permits lighter retention systems, and reduces deflection variations.

The LFD was designed to transport pneumatic and cryogenic fluids and can be useful for any company that deals with fluid connectors, especially those in the aerospace sector where the LFD can be used for flight-to-ground, flight-to-flight, and surface-system applications. . Currently the Technology Transfer Office is engaging with manufacturers, SBIR contenders, and universities interested in evaluating and testing the LFD on their aerospace vehicles.

Due to the issues presented by traditional QDs, the low force disconnect (LFD) was invented by NASA's William Manley, Gabor Tamasy, Tom Ebert in 2010. The design of the LFD utilizes a new, innovative seal arrangement and flow path to eliminate the separation force from the line pressure. Within the new design, the pressure load between the seals is internally reacted, resulting in no net separation load. This load reduction means that the force required for umbilical operations at high line pressures is reduced, allowing the support structures (e.g. umbilical plates, locking devices, vehicle structure, and mating mechanisms) to be lower weight and lower strength, which greatly reduces the system mass.

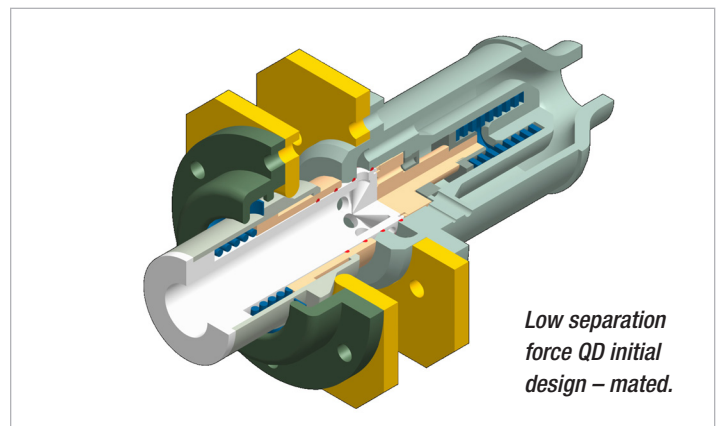

# GenH2 is Revolutionizing the Hydrogen Economy

## Using Many of NASA's Patented Technologies

GenH2, a leading liquid hydrogen (LH2) infrastructure company located in Titusville, FL, focuses on the mass production of products for hydrogen liquefaction, storage, and transfer to further the use of clean, carbon-free energy across the world. They are working to develop liquid-based hydrogen infrastructure solutions that will allow for the safe storage and transfer of LH2 on or near-site to place of use, which will reduce costs associated with the transport and use of LH2 as an energy carrier.

Although it is only a few years old, GenH2 has already formed a strong relationship with NASA through collaboration with current researchers and developers, as well as employment of previous NASA engineers/scientists. NASA and the Technology Transfer office fosters a strong culture of innovation for its inventors, which has been carried on by leading engineers and scientists at GenH2 as they strive to address the challenges facing the hydrogen industry and develop game-changing, breakthrough technologies to bring to the market.

The importance of inventive and innovative approaches at GenH2 are modeled well by two founding members who are also inductees to the select group of NASA Inventors' Hall of Fame. One inductee (2020), James Fesmire, is the Executive Vice-President and Chief Architect of GenH2. He founded the Cryogenics Test Laboratory at the Kennedy Space Center (KSC) and has over 40 years of experience in the field of cryogenics. He is a prolific author, authoring numerous patents, publications, and has also been awarded NASA medals for Distinguished Service, Exceptional Technology Achievement, and Exceptional Service. Dr. Martha Williams, another Hall of Fame inductee (2021), worked as a NASA scientist for 29 years, served as the lead polymer scientist/inventor until she retired in 2018. She has also authored numerous patents, which have resulted in seven active licenses for the KSC Technology transfer office and has received multiple awards including the NASA Commercial Invention of the Year award, Excellence in Technology Transfer Award, NASA Silver Snoopy Award and NASA Silver Achievement Medal.

GenH2 has partnered extensively with NASA's Technology Transfer Office. The Tech Transfer program ensures that the technologies and innovations developed by NASA can be made available to the public, often through licensing agreements with businesses to further develop or commercialize the technologies. GenH2 holds 20 license agreements with the program (including licenses under the Startup program), which is currently the record for the most active NASA patent license agreements held by any private company. Nine of these commercial licenses patent agreements are with KSC, while the others are with the Marshall Space Flight Center (MSFC) and the Glenn



*LS20 Mobile Liquid Hydrogen System*

Research Center (GRC). Of the 20 patents licensed to GenH2, the company has already commercialized several of them—the Layered Composite Insulation for Extreme Conditions (LCX), the Cryostat 500, and the Macroflash instrument. Additionally, GenH2 is currently using licensed data, design concepts, and know-how to develop new products and simulation cryostat platforms for working with LH2 and to contribute to their mainline hydrogen liquefaction and storage products. GenH2 continues to stand out in applying NASA technologies, and in parallel developing new, unique products to bring to the marketplace.

LCX is an insulation system that can be used for complex piping or tank systems, including LH2 systems that are difficult to insulate by conventional means and are utilized in non-vacuum applications and extreme environmental conditions. As a part of the license, the technology is also being commercialized for cold supply chain containers. The system can be tailored to specific performance requirements. The Macroflash instrument is one of multiple cryostat models licensed and utilized by GenH2. The technology was invented by James Fesmire during his time at NASA and has been further developed by GenH2. It has many benefits, as it is compact, easy to use, can run multiple tests per day, and does not require a vacuum chamber setup. The first organization to receive the commercialized product was the South Dakota School of Mines & Technology in Rapid City, South Dakota. The commercial availability of Macroflash, thanks to GenH2 and the Tech Transfer program, will also allow other industry and research organizations to complete testing and research evaluation of common materials as well as more advanced materials and systems.



# PROJECT UPDATE

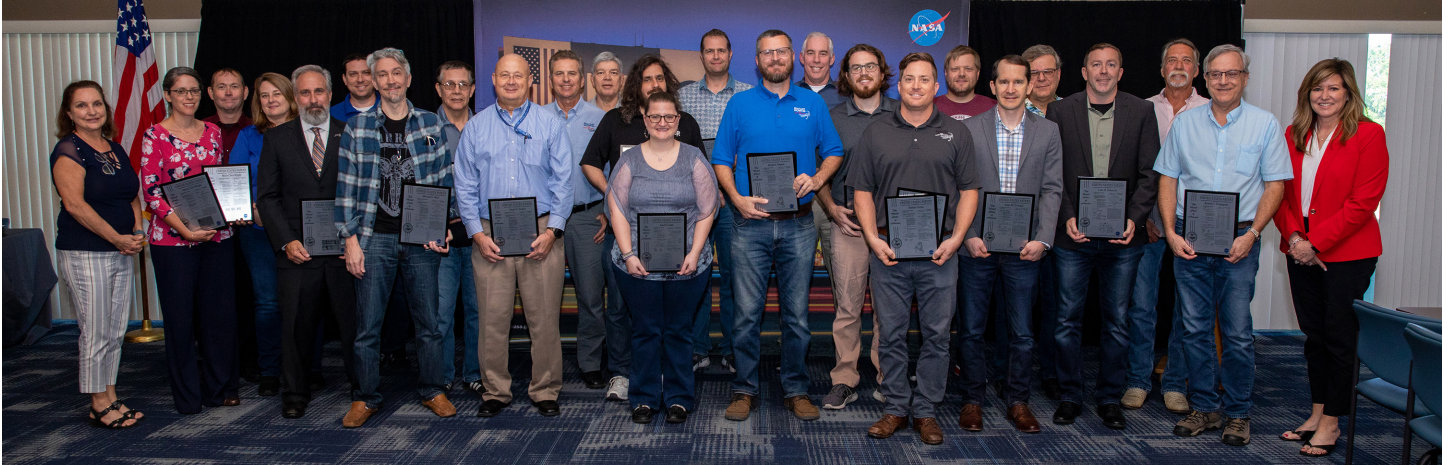

## Innovator Recognition Event

### Kennedy Leaders Celebrate Inventors at Innovator Recognition Event

By Linda Herridge

For the first time since 2018, the latest technologies at Kennedy were celebrated during the 2023 Innovator Recognition event on March 9. At the event, Kennedy leaders presented plaques to 25 NASA employees and seven contractor employees within the Launch Services Program, Engineering Directorate, and the Exploration Research and Technology Programs.

Since January 2020, there have been 151 new invention disclosures, also known as New Technology Reports (NTRs), from 146 NASA and contractor innovators.

Kennedy innovators included on eight or more NTRs from March 2020 to March 2022 were recognized: Jacob Torres; Gioia Massa, Ph.D.; Jeff Richards, Christina Johnson, Ph.D.; Griffin Lunn; and Tracy Gibson, Ph.D. Innovators included on five or more NTRs from the same years included Joel Olson, Ph.D.; Kenneth Engeling, Ph.D.; Ye Zhang, Ph.D.; Jim Mantovani, Ph.D.; LaShelle Spencer; Nathan Gelino; Oscar Monje, Ph.D.; and Dan Batchelder, Ph.D.

The 2021 Best of KSC Software Competition winners also were recognized. The Mission category winner was the Spaceport Command and Control Systems that integrates NASA's Space Launch System core stage, Orion spacecraft, and Interim Cryogenic Propulsion Stage with Kennedy's ground systems to

meet the processing and launch requirements for each Artemis mission. The Institutional category winner was the Secure Notification Application tool that securely enters, tracks, and reports Jacobs Test and Operations Support Contract personnel exposed to COVID-19.

Some technologies were found to have significant value in the conduct of aeronautical and space activities to receive Space Act Awards in 2022. These were the Environmental Test Chamber System (ETCS), Solar Radiance Reflective Coating, Miniaturized Aeroponic Electro-sprayer, and the Close Location Access Wrench (CLAW).

The latest technologies invented at NASA's Kennedy Space Center in Florida were recognized during the 2023 Innovator Recognition event on March 9, 2023. The patent recipients gathered for a group photo after the event held in the Space Station Processing Facility conference center. At far left is Kathy Loftin, chief technologist with the Exploration Research & Technology Directorate. At far right is Jennifer Kunz, Kennedy Space Center associate director, technical. Photo credit: NASA/Kim Shiflett



**NASA TECHNOLOGY  
TRANSFER PROGRAM**

**Kennedy Tech Transfer News** is the magazine of the Technology Transfer Office at NASA's Kennedy Space Center, Florida.

This magazine seeks to inform and educate civil servant and contractor personnel at Kennedy Space Center about actively participating in achieving NASA's technology transfer and partnership goals.



**Hetal Miranda**  
Manager, Technology Transfer Program  
(321) 867-3122  
hetal.miranda@nasa.gov

**Megan Victor**  
Editor  
(321) 867-9724  
megan.e.victor@nasa.gov

<https://technology-ksc.ndc.nasa.gov>

National Aeronautics and Space Administration

**John F. Kennedy Space Center**  
Kennedy Space Center, FL 32899  
[www.nasa.gov/centers/kennedy](http://www.nasa.gov/centers/kennedy)

[www.nasa.gov](http://www.nasa.gov)

NP-2023-07-759-KSC