

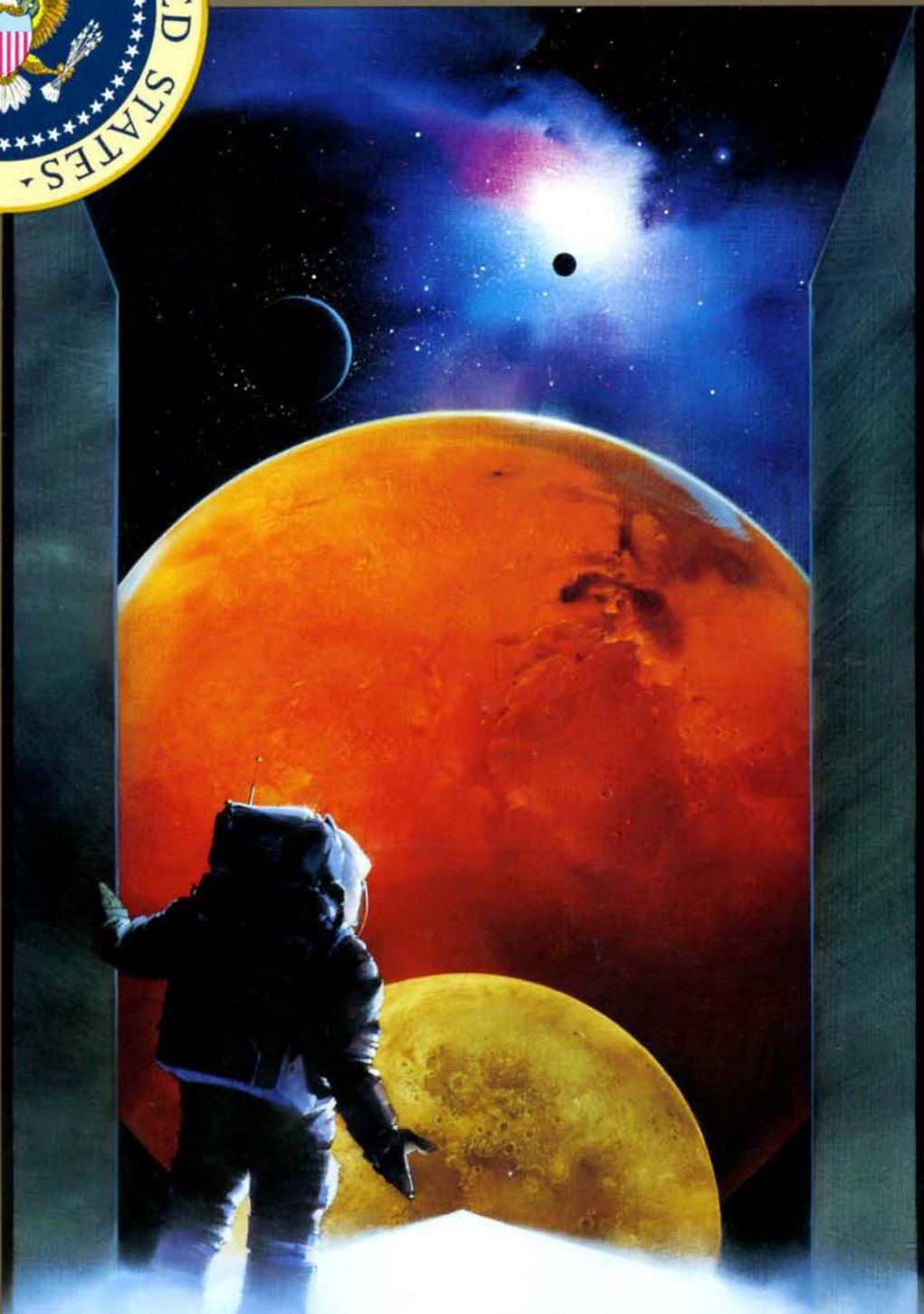

AMERICA AT THE THRESHOLD



**AMERICA'S
SPACE EXPLORATION INITIATIVE**

AMERICA AT THE THRESHOLD

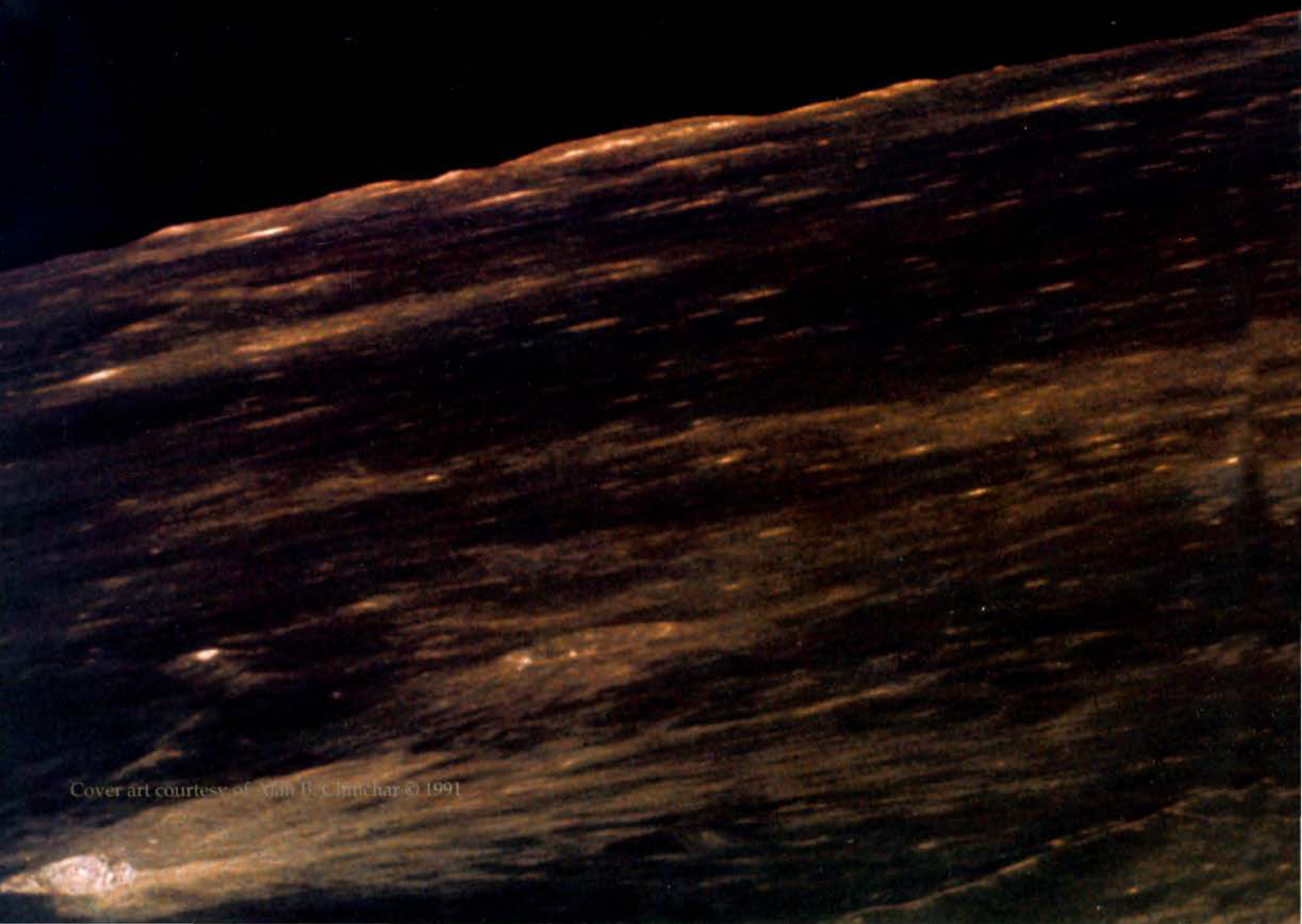

Cover art courtesy of Alan B. Clutcher © 1991

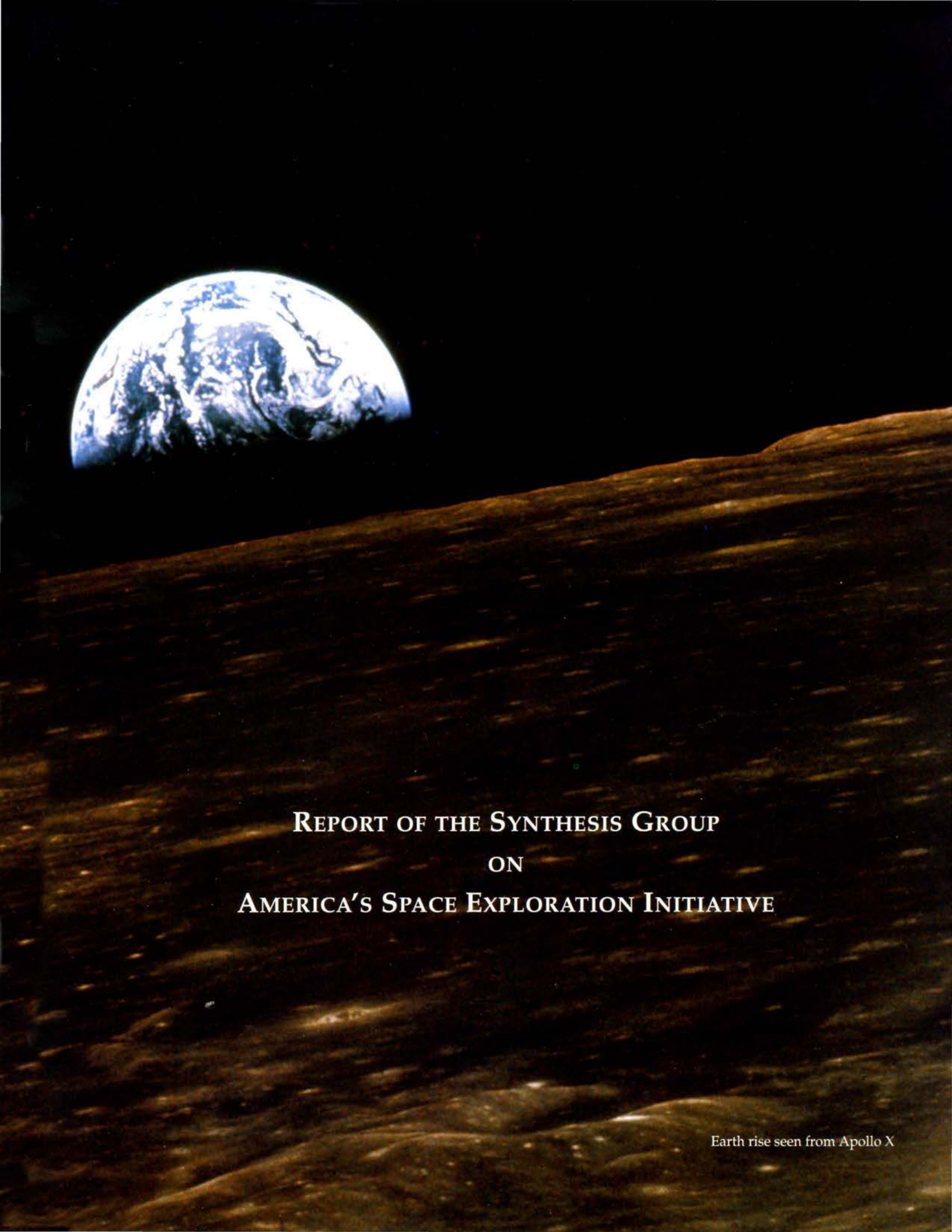

**REPORT OF THE SYNTHESIS GROUP
ON
AMERICA'S SPACE EXPLORATION INITIATIVE**

Earth rise seen from Apollo X



THE VICE PRESIDENT
WASHINGTON

May 6, 1991

Lieutenant General Thomas P. Stafford, USAF (RET.)
Chairman, Synthesis Group
1225 Jefferson Davis Highway, Suite 1501
Arlington, VA 22202

Dear Tom:

President Bush challenged us to chart a course to the future, for the benefit of humanity. His vision of America's future in space, the Space Exploration Initiative, will enable our nation to journey together back to the Moon and on to Mars. Your report meets that challenge.

You have offered the nation several alternatives which demonstrate a thorough understanding of the imperatives of space, an appreciation of political and economic realities, and concern for humanity's needs on Earth. Your effort represents an integral part of a balanced plan of exploration, future acquisition of scientific knowledge, and future space leadership. I am grateful to you and your associates for this landmark contribution.

I want to express our sincere appreciation to you and the Synthesis Group for a thorough, useful, and timely effort. As we journey back to the Moon and on to Mars, we will be mindful that the Synthesis Group roadmap suggested the way. And as humanity benefits from the fruits of this journey, we will acknowledge President Bush's vision and your translation of that vision into a robust, safe, affordable and beneficial voyage.

Sincerely,

Synthesis Group

May 3, 1991

The Honorable J. Danforth Quayle
Chairman, National Space Council
The White House
Washington, D.C. 20500

Dear Mr. Vice President:

I am pleased to submit the attached report "America at the Threshold" in response to your request. This report is the result of contributions by a great number of people desiring to participate in the Space Exploration Initiative. The Outreach Program, implemented by NASA, included studies by the American Institute of Aeronautics and Astronautics, proposals from individuals throughout the nation and contributions from government departments and industrial concerns. These all combined to form the basis of our evaluation. With the advice and counsel of senior members, this report was prepared by a group of dedicated experts made available to the Synthesis Group by departments and agencies throughout the government, private corporations and universities.

Our conclusions support America's goal to provide this generation a robust, safe, and affordable future in space while ensuring the greatest benefit for mankind on Earth.

Sincerely,



Thomas P. Stafford
Lieutenant General USAF (Ret.)
Chairman, Synthesis Group

FOREWORD

There are times when seemingly small decisions reverberate through the centuries. Now is such a time. The decisions we make now for space will set the nation's course for decades, if not centuries to come. The legacy we leave to future generations may well be decided in these next few years.

The Past

In the 15th century, China may well have been the most technologically and culturally advanced state on Earth. It owned great fleets of large oceangoing ships. In 1433, a fleet of Chinese ships sailed all the way to Africa, trading, exploring, and advancing Chinese culture. But the Ming Empire had other priorities — problems at home, pressing needs elsewhere. They recalled the fleet — and then they burned it. They wanted to bring an end to “wasteful” exploring. And they also wanted to ensure that Chinese explorers would not even be tempted to venture forth again for a long, long time.

At about the same time that China was burning its fleet, a small European nation's farsighted leader, Prince Henry of Portugal — now known as Henry the Navigator — sent ships up and down the coast of Africa. Soon another European nation, Spain — just emerging from centuries of war and turmoil — also began an exploration program. For a time, Portugal and Spain competed to explore and use the new world that Spain discovered.

Portugal did not completely abandon exploration, as China did. But Portugal soon lost out to Spain through gradual loss of sea exploration capabilities. Spain went on to reap the harvest of two continents — ushering in a golden age for its people which was to last almost two centuries. With the destruction of the Spanish Armada, the British seized the leadership position with such expeditions as Sir Francis Drake's world voyage and Captain Cook's Pacific voyages.

Nations lose their leadership position when they give up the role of exploration. The question now facing the United States is which path to take with regard to “oceans” of the 21st century.

The Present Challenge

In 1989, President George Bush challenged America in a way no one has challenged us before, “. . . back to the Moon, back to the future. And this time, back to stay. And . . . a journey into tomorrow . . . a manned mission to Mars.” In the history of the human race, no technological challenge has been so great, and no goal so distant. Likewise, there has never been a nation like ours, nor an opportunity so promising.

Ours is a rapidly changing world. To remain competitive and maintain world leadership in the 21st century, America will need the best trained and educated work force, the most advanced technology and the strongest leadership. We now have goals that challenge our abilities far beyond what we've experienced before.

The Space Exploration Initiative is a vision for the 21st century. It is a vision of America reaching beyond itself, and onward, beyond the very bounds of this planet to an entirely new world. On the way there, we will reap the real, tangible benefits of space exploration.

Space is clearly our most challenging frontier. Enroute to Mars, we will explore the Moon, advance Earth sciences, and develop new, innovative technologies. We will tap lunar, Martian and solar energy resources as we explore the heights of human talent and ability. Along the way, America's drive, initiative, ingenuity and technology — all those things that have made our nation the most successful society on Earth — will propel us toward a future of peace, strength and prosperity. The challenge is before us. This report shows how we begin.



"We are living at the very beginning of time. We have come into being in the fresh glory of dawn, and a day of almost unthinkable length stretches before us with unimaginable opportunities for accomplishment. Our descendants of far-off ages, looking down this long vista of time from this other end, will see our present age as the misty morning of human history. Our contemporaries of today will appear as dim, heroic figures who fought their way through the jungles of ignorance, error, and superstition to discover truth."

Sir James Jeans, Astronomer, 1930

The Earth Viewed from Apollo X



TABLE OF CONTENTS

EXECUTIVE SUMMARY	2
INTRODUCTION	10
WHY THE SPACE EXPLORATION INITIATIVE?	12
ARCHITECTURES	16
CONSIDERATIONS AND CONSTRAINTS	18
COMMON ACTIVITIES.....	26
ARCHITECTURE I.....	34
ARCHITECTURE II	40
ARCHITECTURE III	46
ARCHITECTURE IV	52
CONCEPT ALTERNATIVES	58
SUPPORTING TECHNOLOGIES	64
ORGANIZATION AND ACQUISITION MANAGEMENT.....	84
OPERATIONS AND FACILITIES.....	90
LIFE SCIENCES.....	98
EDUCATION.....	104
RECOMMENDATIONS.....	112
APPENDIX	
MEMBERSHIP	A - 2
LEGACIES	A - 8
WAYPOINTS.....	A - 9
THE OUTREACH PROCESS	A-44
GLOSSARY	A-59
BIBLIOGRAPHY	A-61
ART ACKNOWLEDGEMENTS.....	A-67

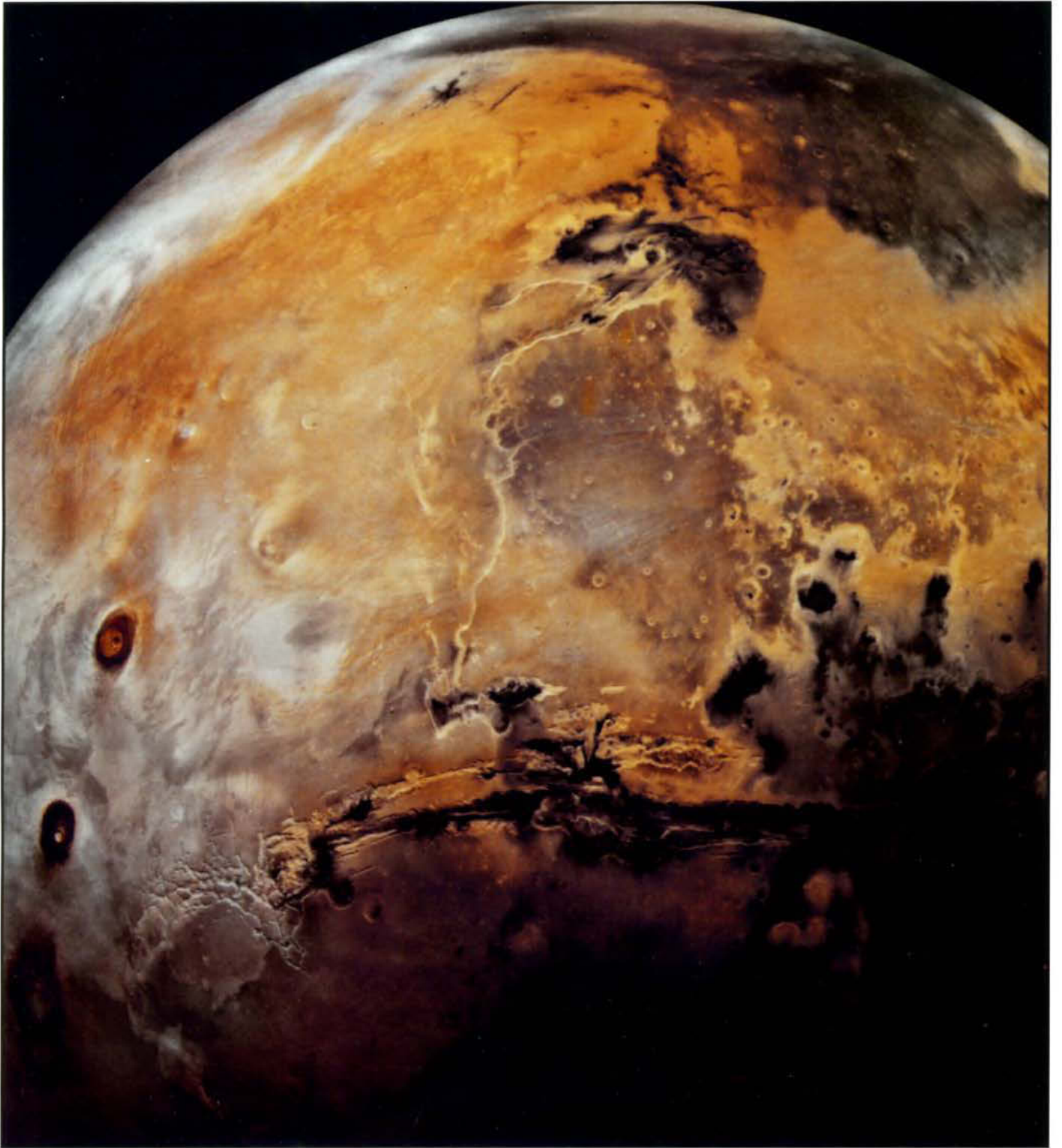

Mars Mosaic from Viking Orbiter 1.

Apollo 11 first placed America on the Moon on July 20, 1969. This extraordinary accomplishment confirmed the United States' technological ascendancy for a generation. On the 20th anniversary of Apollo 11, President George Bush announced a new vision for America in the 21st century — a vision that will return us to the Moon to stay, and onward to Mars by 2019. This vision, the Space Exploration Initiative, represents one of the greatest technological challenges the world has ever known.

Vision for America

The Space Exploration Initiative provides a focus that allows the United States to gain control of our destiny in space. In doing this, six "visions" guide and direct our space efforts. These are:

Knowledge of our Universe. We strive to understand the origin and history of our Solar System, the origin of life, and the ultimate fate of our universe. People are the best explorers, but they often need machines to help. *The Space Exploration Initiative is an integrated program of missions by humans and robots to explore, to understand and to gain knowledge of the universe and our place in it.*

Advancement in Science and Engineering. Returning to the Moon and onward to Mars requires the best engineering and scientific talent our nation can muster. Through a long range commitment to space, we stimulate our national education system and inspire students to learn. Motivated students are essential to excellence in education. *The Space Exploration Initiative will motivate and inspire the new generations on which our future as a nation depends.*

United States Leadership. The Space Exploration Initiative provides us with an opportunity to re-establish

and maintain American preeminence in technological innovation and space leadership. Other nations have gained the initiative in certain areas and have become leaders in a tradition of space exploration that America pioneered. *Leadership cannot be declared . . . it must be earned.*

Technologies for Earth. America's recent history has demonstrated that our space program stimulates a wide range of technological innovations that find abundant application in the consumer marketplace. Space technology has revolutionized and improved our daily lives in countless ways, and it will continue to do so. Energy from space, advances in solar power and fusion fuels, useful materials for advanced communications, new resources, medical breakthroughs, and greater insight into the human potential are some of the direct benefits we can expect. *The Space Exploration Initiative provides focused goals to effect practical and beneficial technological change.*

Commercialization of Space. Initiatives by the private sector are goals of our National Space Policy. Space is a limitless, untapped source of materials and energy, awaiting industrial development for the benefit of humanity. *Commercial products, such as zero gravity derived materials, and service industries, like advanced global communications, all become increasingly feasible and profitable once routine, reliable and affordable access to space is available.*

Strengthened U.S. Economy. New technologies open new markets. An investment in the high technology needed for space exploration maintains and improves America's share of the global market and enhances our competitiveness and balance of trade. It also directly stimulates the scientific and technical employment bases in our country, sectors whose health is vital to our nation's econom-

"The challenges of the Space Exploration Initiative are great, but so is the quality of American talent and ingenuity, and so is the leadership of the American people. And . . . it is America's destiny to lead."

President George Bush

ic security. *The Space Exploration Initiative is an investment in the future of America.*

Why the Moon?

Earth's closest neighbor in space, the Moon, is surprisingly complex. It is an object for detailed exploration, a platform from which to observe and study the universe, a place to live and work in the environment of space, and a natural source of materials and energy for an emerging space-based economy.

The Moon offers a record of four billion years of planetary history. Its violent birth and history of bombardment from space is closely related to events on the early Earth. The Moon provides a natural laboratory for detailed study of geology and planetary formation, the output of our Sun over its lifetime, and the elements of our universe. The Moon's 14 Earth-day night, crystal clear, airless sky and stable ground provide a superb platform for astronomy.

The Moon is the nearest object in space where people can live under conditions similar to those we will face on other planets. Thus, the Moon is a natural test bed to prepare for missions to Mars through simulation, systems testing, operations and studying human capabilities.

The Moon is a rich source of materials and energy for use in space. Abundant metals, ceramics and recoverable amounts of hydrogen, carbon and oxygen can provide propellants and human life support from the lunar surface. The 14 Earth-days of a lunar daytime provide abundant solar energy. Our Moon provides a rich scientific and economic waystation for human expansion into the Solar System.

Why Mars?

Of all the planets in our Solar System, Mars is the most like Earth. With a thin atmosphere, weather, seasons



and a 25-hour day, Mars has a diverse and complex surface, including ice and evidence of water. Although conditions on Mars cannot support life now, a variety of evidence suggests that Mars was warmer, wetter and had a much denser atmosphere early in its history. Life may have existed. If so, fossil evidence may be found.

Mars has undergone a complicated geologic evolution. Its surface consists of gigantic canyons, huge volcanoes, gorges carved by running water, vast regions of sand dunes and a polar ice cap. Understanding the periodic changes in climate that have occurred on Mars will help us understand the Earth's climate and predict its future behavior, a topic vital to the survival of life on Earth.

Architectural Considerations

At its closest point, Mars is 35 million miles from Earth. This distance increases to 230 million miles when we are on opposite sides of the Sun. By comparison, the Moon is only a quarter-million miles away — a three-day journey. The challenges of a Mars expedition stem from the distances, the long times away from Earth, the environment of deep space and Mars' unique characteristics.

A total Mars mission duration depends on both the round trip travel time and the time spent on the planet's surface. Conventional chemical propulsion missions will take about 230 days one way, and require long surface stays of about 500 days to allow the planets to realign before returning home. Advanced nuclear propulsion technologies can shorten the transit time, provide flexible surface stay times, significantly reduce the propellant mass to low Earth orbit and increase the available launch opportunities.

Shorter travel times are desirable to reduce the impact of the deep space environment on the crew and

mission equipment. During the space voyage, expected hazards include radiation from galactic cosmic radiation and solar flares, the lack of normal gravity, psychological stress from long term isolation, and equipment degradation.

The challenges of a Mars trip will require several hundred tons of equipment and fuel for the expedition. Thus, we will require a heavy lift launch capability to minimize assembly in Earth orbit. Nuclear propulsion technology allows reduced weight, approximately one-half that of chemical systems, and achieves faster interplanetary trip times. At Mars, we need Earth-independent operations, since round trip communications times will vary from seven to 40 minutes. We also need improved long term life support systems that operate for lengthy time periods without resupply.

The planetary surface of Mars provides challenges different from those of the Moon. The planet is large — about one-third the size of Earth. It has a diverse topography, with 80,000 foot volcanos, three times as high as Mount Everest and as large as the state of Montana, and canyons as long as our continent is wide. Mars' atmosphere is mostly carbon dioxide, and it is known to have periodic dust storms. These features will require unique power systems, landers, rover vehicles and human habitats.

Architectures

The foundation of the architectures reflects three areas of emphasis: human presence, exploration and science, and space resource development for the benefit of Earth. Different architectures vary with the degree of human presence, the level to which exploration and science are pursued, the extent to which space resources are developed, as well as the relative emphasis between lunar and Martian activity.

Four architectures have been identified and they provide significant differences across the possible areas of interest. They are:

Mars Exploration: The emphasis of this architecture is on Mars exploration and science. The first human mission to the Moon occurs in 2005. The lunar infrastructure is developed only to the degree necessary to test and gain experience with Mars systems and operations and to simulate Mars stay times. The Moon is explored while developing operational concepts for Mars.

Robotic precursor missions are used to scout the territory before committing to a landing site for Mars. The first human mission to Mars occurs in 2014, with a surface stay of 30 to 100 days. The next mission is planned for 2016 for a 600 day stay. This architecture is designed to be a minimal approach to achieving the Initiative objectives.

Science Emphasis for the Moon and Mars: The Moon and Mars are emphasized equally, and an early global assessment of both bodies permits a variety of initial missions designed to better understand global diversity. The first human mission to the Moon is 2003. Life sciences data required for Martian missions are generated through extensive operations on the Moon. Human-controlled robotics assist the planning and execution of human activity on the surface. Instrument emplacement focuses on early deployment of portable instruments which gather observation data independent of lunar location. In the latter stages of architecture implementation, emphasis shifts to larger scientific experiments and instruments after developing surface capabilities for construction, maintenance and operations. Continuous exploration activities yield a significant scientific return though the use of a balanced mix of human and robotic exploration techniques.

Subsequent to the establishment of the desired long term operational capabilities for exploration and science on the Moon, human missions to Mars take place beginning in 2014. All knowledge gained by the activities in lunar orbit, and on the surface becomes part of and is complementary to the dress rehearsal for the Mars mission.

The Moon to Stay and Mars Exploration: This architecture emphasizes permanent human presence on the Moon, combined with the exploration of Mars. One of the major objectives is to build towards life support self-sufficiency for breathing gases and food production on the Moon.

The permanent presence of humans on the Moon, beginning in 2004, gives us an impressive scientific capability. Science on the Moon will emphasize exploration and observation. For lunar exploration, extended traverses in pressurized rovers will permit detailed study of complex and puzzling lunar features and processes. Robotic assistants will extend human reach for great distances across the lunar surface. With a permanent human presence on the Moon, advanced and sophisticated astronomical observatories can be installed and maintained.

Extensive space and lunar surface operations are conducted on the Moon to provide the necessary life sciences and engineering data to prepare for future exploration missions to Mars. The first human mission to Mars is in 2014, with a surface stay of 30 to 100 days.

Space Resource Utilization: This architecture makes maximum use of available space resources to support the exploration missions directly. It also seeks to develop a large class of available resources for a broader range of transportation, habitation, life sciences, energy production, construction and many other long term

Architectures

- I. Mars Exploration
- II. Science Emphasis for the Moon and Mars
- III. The Moon to Stay and Mars Exploration
- IV. Space Resource Utilization



Beyond the Moon

activities. In preparation for the first human return mission, a robotic experimental resource producing plant is landed on the Moon in 2003. The first human mission to the Moon takes place in 2004 and to Mars in 2016. On Mars, the basic exploration would be done on the first two missions with the addition of more resource development, which could be expanded on missions beyond the first two. In the long term, this architecture may benefit Earth by providing Helium-3 to fuel Earth-based fusion reactors and beaming solar-produced electricity to Earth.

Transportation

After study of the various transportation options, it was concluded that chemical propulsion from low Earth orbit, as used in the Apollo program, is still the preferred way to get to the Moon. However, significantly heavier lift capability will be required to support any of the architectures. For the Mars transit from Earth orbit, the nuclear thermal rocket is the preferred propulsive system to allow significantly reduced mass to low Earth orbit, shorter transit times and greater operational flexibility.

Supporting Technologies

Technology will provide the tools necessary for safe and cost effective exploration of the Moon and Mars. Technology development is required in the following areas:

- 1) Heavy lift launch with a minimum capability of 150 metric tons with designed growth to 250 metric tons
- 2) Nuclear thermal propulsion
- 3) Nuclear electric surface power to megawatt levels

- 4) Extravehicular activity suit
- 5) Cryogenic transfer and long term storage
- 6) Automated rendezvous and docking of large masses
- 7) Zero gravity countermeasures
- 8) Radiation effects and shielding
- 9) Telerobotics
- 10) Closed loop life support systems
- 11) Human factors for long duration space missions
- 12) Lightweight structural materials and fabrication
- 13) Nuclear electric propulsion for follow-on cargo missions
- 14) In situ resource evaluation and processing

At first glance, the implementation of the architectural approaches outlined appears daunting. It is indeed complex. But it is noteworthy that America's ability to return to the Moon and to begin the exploration of Mars depends on two fundamental technologies:

- 1) Restoration of a heavy lift launch capability
- 2) Redevelopment of a nuclear propulsion capability

This nation had both of these capabilities in the early 1970s. In addition to these two areas, the 12 other technologies identified, if successfully developed, offer the potential for vastly enhancing the exploration of the Moon and Mars.

Organization and Acquisition Management

The Space Exploration Initiative represents a major management challenge as well as a significant technological challenge to this country. The capability exists in this nation to accomplish the Space Exploration Initiative within the combined resources of the government, industry and the academic community. It requires management that allows for crisp and timely decision making, plus the assured resources to reach its goals.

An Executive Order should be issued to cite the basic charter of the National Program Office for the Space Exploration Initiative Organization. It should define the leadership role of NASA and the cooperative relationships among various governmental departments and agencies. The Executive Order should clearly enumerate the staffing, budgeting and reporting relationships and responsibilities of the affected agencies.

The Synthesis Group reviewed numerous successful and unsuccessful major aerospace, industry and government programs, and studied various acquisition improvements and key factors that helped reduce the cost of the most successful aerospace programs.

In managing the Space Exploration Initiative, NASA should be authorized to tailor the existing procurement system and devise new procedures to fit the needs of this major new program.

The opportunity for a number of international cooperative ventures exists.

Commercial potential abounds within the framework of the Initiative. Launch services, communications satellites, robotics, production of materials in space for use in space and on the Earth, and electronics technology represent a few of these potential areas.

Recommendations

Specific recommendations are provided for the effective implementation of the Space Exploration Initiative.

RECOMMENDATION 1

Establish within NASA a long range strategic plan for the nation's civil space program, with the Space Exploration Initiative as its centerpiece.

“. . . the jewel represented by the vision of a seemingly unattainable goal, the technologies engendered, and the motivation provided to our nation's scientists and engineers, its laboratories and industries, its students and its citizens. Hence that the Mission from Planet Earth be established with the long term goal of human exploration of Mars, underpinned by an effort to produce significant advances in space transportation and space life sciences.”¹

A strategic plan will provide decision points to allow flexibility during the life of the program, concentrate management activities of diverse departments, provide budget guidelines and identify technology pathways. The plan must be based on a detailed governmental (NASA, the Department of Defense, the Department of Energy) analysis of the Synthesis Group's four architectures. This analysis should result in further refinement to gain sufficient detail to support relative costing of the architectures. Existing and planned programs should be reviewed for their contributions to this plan. Industry effort should be limited to studying elements of the architectures. As the strategic plan's centerpiece, the Space Exploration Initiative complements the goals of Mission to Planet Earth.²

RECOMMENDATION 2***Establish a National Program Office by Executive Order.***

This organization would include Department of Defense and Department of Energy personnel working directly for the National Program Office. With the multi-agency nature of the National Program Office, an Executive Order should be issued to cite the basic charter of the organization, the leadership role of NASA, and the cooperative relationship among various governmental departments and agencies. The Executive Order should clearly enumerate staffing, budgeting and reporting relationships and responsibilities of the affected agencies.

RECOMMENDATION 3***Appoint NASA's Associate Administrator for Exploration as the Program Director for the National Program Office.***

This is required to ensure clean lines of management authority over a large, complex program while simultaneously providing a focus for NASA's supporting program elements.²

RECOMMENDATION 4***Establish a new, aggressive acquisition strategy for the Space Exploration Initiative.***

The Space Exploration Initiative should standardize acquisition rules for the agencies executing the Initiative's various projects. The most streamlined processes available should be adopted for that standard. The Space Exploration Initiative is so great in scope that it cannot be executed in a "business as usual" manner and have any chance for success. The

Space Exploration Initiative National Program Director should be designated as the Head of the Contracting Activity. This will allow the director to establish the optimum acquisition procedures within the Federal Acquisition Regulations. Multi-year funding should be provided.

RECOMMENDATION 5***Incorporate Space Exploration Initiative requirements into the joint NASA-Department of Defense Heavy Lift Program.***

The Space Exploration Initiative launch requirement is a minimum of 150 metric tons of lift, with designed growth to 250 metric tons. Using Apollo Saturn V F-1s for booster engines, coupled with liquid oxygen-hydrogen upper stage engines (upgraded Saturn J-2s or space transportation main engines), could result in establishing a heavy lift launch capability by 1998.²

RECOMMENDATION 6***Initiate a nuclear thermal rocket technology development program.***

The Synthesis Group has determined the only prudent propulsion system for Mars transit is the nuclear thermal rocket. Sufficient testing and care must be taken to meet safety and environmental requirements.

RECOMMENDATION 7***Initiate a space nuclear power technology development program based on the Space Exploration Initiative requirements.***

The program must concentrate on safe, reliable systems to a megawatt or greater level. These nuclear power

"We propose . . . to accelerate the development of the NOVA nuclear rocket. This gives promise of some day providing a means for even more exciting and ambitious exploration of space, perhaps beyond the Moon, perhaps to the very end of the solar system itself."

John Fitzgerald Kennedy

systems will be required for use on the Moon before use on the Mars mission.

RECOMMENDATION 8

Conduct focused life sciences experiments.

Implement a definitive life sciences program, along with the necessary experiments and equipment, on Space Station Freedom, consistent with the recommendation of the Advisory Committee on the Future of the U.S. Space Program. These experiments are needed to reduce the uncertainties of long duration space missions.²

RECOMMENDATION 9

Establish education as a principal theme of the Space Exploration Initiative.

The Initiative will require scientists, engineers and technicians for its execution. It is a source of interest and expectation to those considering science and engineering careers. The Space Exploration Initiative can contribute directly to undergraduate and graduate education in engineering and science by re-invigorating a university research program in support of the Exploration Initiative as was done during the Apollo program of the 1960s and early 1970s.

RECOMMENDATION 10

Continue and expand the Outreach Program.

The Outreach Program has served a very useful purpose in the Synthesis Group's deliberations. The ideas from the Outreach Program will be turned over to NASA with the recommendation that they review them

periodically. The Outreach Program generated not only ideas but also greater interest in the Space Exploration Initiative. Both features should be emphasized. The database should be refreshed with further outreach solicitations, perhaps every two years, and with increasing focus to specific program goals. The Space Exploration Initiative touches virtually every scientific field and engineering discipline. The Outreach Program should be extended to include all other entities that are affected by the program in addition to the aerospace industry. An informed public is vital to the Space Exploration Initiative, which will require a sustained commitment of the nation's resources.

Why Now?

America stands at the threshold. Our national space program is undergoing intense scrutiny. Many ask questions similar to those voiced during the heyday of Apollo — What is the point of large space ventures? How can we afford the great expenditures? What is the function of a human presence in space?

By offering direction and purpose, the Space Exploration Initiative will rejuvenate our sense of challenge, of competitiveness, and of national pride. The Space Exploration Initiative is a positive, social endeavor. In a world of uncertainty, it has the capacity to inspire people, to stimulate them and to cause them to reach deep inside to find the very best they have to offer.

Technology development and architecture analysis must precede any final concept validation effort. The Initiative can be started now with a modest commitment of funds.

Great nations have always explored and profited from new frontiers and territories. Space is the new frontier of the industrialized world in the 21st century. Benefits from space and the technologies needed to journey there become increasingly important in the

next century. As Americans, we must ask ourselves what our role will be in human exploration of the Solar System: to lead, follow or step aside?

¹ The Advisory Committee on the Future of the U.S. Space Program.

² These recommendations are consistent with and expand upon those made by the Advisory Committee on the Future of the U.S. Space Program.

Origin of the Space Exploration Initiative

On the 20th anniversary of the first lunar landing mission, Apollo 11, President Bush outlined a program that would put the United States on an aggressive track to return to the Moon to stay, and to land humans on Mars. The President's space policy calls for expanding human presence and activity beyond Earth orbit into the Solar System; obtaining scientific, technological and economic benefits for the American people; encouraging private sector participation in space; improving the quality of life on Earth; strengthening national security; and promoting international cooperation in space. The Space Exploration Initiative accomplishes these goals. In August 1989, NASA began an extensive review to summarize the technology and strategies for going back to the Moon and on to Mars.

The Outreach Program

Vice President Quayle, Chairman of the National Space Council, realized

that the complexity and challenge of the program would require the best minds within the government, industry, academia and throughout the country. He requested NASA "to cast a net widely to find the most innovative ideas in the country." These ideas were solicited by the Administrator of NASA, Richard H. Truly, through an Outreach Program of personal letters and public announcements.

The Synthesis Group

Lieutenant General Thomas P. Stafford, USAF (Ret.), a Gemini and Apollo astronaut and Commander of the Apollo-Soyuz Test Project, was asked by Vice President Quayle and Administrator Truly to serve as chairman of a group to analyze and synthesize the recommendations of the Outreach Program. Lieutenant General Stafford assembled a group of individuals from the Office of the Secretary of Defense, U.S. Army, U.S. Navy, U.S. Marine Corps, U.S. Air Force, the Department of Energy, the Department of Commerce, the Department of Health and Human Services, NASA, academia and industry. The Synthesis Group was chartered to provide two or more significantly different architectures, technology priorities and the early accomplishments to support the nation's Space Exploration Initiative.

Twenty-three senior members, all professionals with vast experience and of national regard, participated. These senior members met periodically to review progress and participated in working sessions to direct the Synthesis Group's efforts.

In order to determine the breadth and scope of a program, it is essential to identify its goals. To provide a frame of reference for the Space Exploration Initiative, it was necessary to determine activities to be accomplished on the Moon and on Mars. Then, and only then, could it be decided how to provide a capability for accomplishing these activities.



The Synthesis Group initially concentrated on the major topical activities to be performed on the planetary surface. These activities, called Waypoints, were further bounded by defining incremental capabilities. Each incremental capability is a significant achievement in itself.

Waypoints
<p>Moon Waypoints</p> <ul style="list-style-type: none"> • Lunar Exploration • Preparation for Mars • Habitation • Lunar Based Observation • Fuels • Energy to Earth <p>Asteroids Waypoint</p> <p>Mars Waypoint</p>

The Architectures

Architectures were developed which reflect the National Space Visions. Technical strategies were defined that were common to all. Three areas of variability were also identified. These differences result from the degree to which each of the following emphases are developed and pursued:

- Emphasis on Exploration and Science
- Emphasis on Human Presence
- Emphasis on Space Resource Development

The balance between activities on the Moon and Mars is another factor that

offers a distinction between architectures.

The concepts of Initial Operational Capabilities and Next Operational Capabilities are important to the architectures, as they provide logical decision points within the Initiative. Decision points allow necessary flexibility during the life of the Initiative to modify the emphasis, adopt new technologies or respond to changes in available funding.

This document describes the architectures, technologies and recommendations of the Synthesis Group. Technology priorities are identified within the Supporting Technologies section of this report. Early accomplishments are identified within their respective sections of the report. The visions and architectures describe pathways back to the Moon to stay, and onward to Mars. Collectively, they represent a vision of America's space program as we enter the 21st century.

National Space Visions
<ul style="list-style-type: none"> • Increase our knowledge of our solar system and beyond • Rejuvenate interest in science and engineering • Refocus U.S. position in world leadership (from military to economic and scientific) • Develop technology with terrestrial application • Facilitate further space exploration and commercialization • Boost the U.S. economy

*For I dipt into the future, far as human eye could see,
Saw the Vision of the world, and all the wonder that would be;*

*Saw the heavens fill with commerce, argosies of magic sails,
Pilots of the purple twilight, dropping down with costly bales.*

– Alfred Lord Tennyson, “Locksley Hall” 1842

Thirty years ago, President Kennedy challenged the nation to land a man on the surface of the Moon, return him safely to the Earth and to do so within a decade. This was a challenge unprecedented in the history of humanity. Not only was President Kennedy’s goal accomplished ahead of schedule, it also led to an unparalleled series of space and technological achievements and a vigorous civilian space program. American preeminence in space was unquestioned, and we reaped the benefits of that position technically, scientifically, economically and politically.

Many people believe that the U.S. no longer enjoys the space leadership earned during the Apollo program. Now that President Bush has challenged the nation with a new vision of America’s future in space, the Space Exploration Initiative offers hope that the nation can gain control of its own destiny in space.

National Space Visions

Derived from the National Space Policy and other documents, the Synthesis Group established the following broad visions for the Space Exploration Initiative:

Increase our knowledge of the Solar System and beyond. The exploration of space yields knowledge of the universe and of our place in it. We seek to understand the origin and history of the planets in our Solar System, the

origin of life and the ultimate fate of our universe. These questions are not suddenly answered by some single piece of information or mission, but require a series of investigations and missions that collectively advance our understanding.

An important aspect of the Initiative is the use of people as instruments of exploration. Human powers of observation uniquely permit some scientific investigations. Many difficult tasks, such as the search for fossil life on Mars, require human presence. A machine can be built to retrieve a rock; only a human can intelligently select a planetary sample while understanding its regional and local context. The Space Exploration Initiative constitutes a combined and balanced program of human and robotic missions. *Such an effort, intelligently planned, can accomplish many more exciting and significant results than either approach taken separately.*

Rejuvenate interest in science and engineering. The Space Exploration Initiative is a science and engineering task of enormous magnitude. Its successful implementation requires outstanding scientists, engineers and technicians. Because the Initiative is a long range, continuing commitment to space, national education must become an integral part of the program. Such education must encompass both the academic establishment and the general public. Information system technologies permit the widespread dissemination of knowledge from space missions; this includes television and “telepresent” media that allow the public to share in space activities as they occur. Programs to involve universities directly in the Initiative, similar to those during the Apollo era, can rejuvenate our base of scientific and technical expertise.

Because the exploration of space spans the activities of society, the Space Exploration Initiative has the potential to initiate achievements in a

wide spectrum of disciplines. *The Space Exploration Initiative will motivate and inspire the new generations on which our future as a nation depends.*

Refocus U.S. position in world leadership. The Space Exploration Initiative provides us with an opportunity to re-establish and maintain American preeminence in space, both on a practical level and in the intangible areas of national prestige. One of the main benefits of the Apollo program was technical innovation. Deadlines and strict requirements push technology development. The Initiative will create imaginative technologies and approaches because, as we move down the decision paths and receive funding, we will need them immediately for real activities and missions. This is a much more effective method of innovation than waiting for technologies to mature naturally, without a focus.

Other nations have seized the initiative and, in certain areas, have become leaders in a tradition of space exploration that America pioneered. Our national ethic is based on a sense of manifest destiny and leadership in new fields of endeavor. *Leadership, however, cannot be declared . . . it must be earned.*

Develop technology with terrestrial application. The space program has traditionally stimulated technical innovations that have found abundant application in the marketplace, and space technology has revolutionized and improved our daily lives in countless ways. Transportation, medicine and communications are just a few areas where space technology has made consumer goods safer, more effective, more affordable and easier to use.

Space technology provides several potential alternatives for producing energy. Solar power or fusion fuels could ultimately provide clean and safe energy for the terrestrial economy. *The Space Exploration Initiative*

plays a significant role in the innovation of new technologies because it promotes focused goals to effect practical and beneficial technological change.

Facilitate further space exploration and commercialization. The encouragement of private sector activity in space is part of our National Space Policy. Routine, reliable and affordable access to space is required for significant industrial activity. Large scale industry in orbit requires a reliable heavy lift launch vehicle. The Space Exploration Initiative provides a focus and rationale for the development of heavy lift launch vehicle technology, and will generate a launch rate that will attract commercial interests.

Space is a vast, untapped source of materials and energy awaiting industrial development for the benefit of humanity. *The production of commercial products and service industries all become feasible once routine and reliable access to space is available.*

Boost the U.S. economy. The needs of the Space Exploration Initiative will directly stimulate the scientific and technical employment base of the country, sectors whose health is vital to our nation's economic security. The Initiative will generate new opportunities for thousands of engineers, scientists, technicians and manufacturing personnel. Because a variety of additional jobs will be established to support the efforts of large programs, the cascade effect will produce additional employment opportunities, many in peripheral, non-technical fields.

Creation of technologies has always opened new markets; historically, we have led the world in profiting from technology. Aerospace technology is one of the few areas where America retains a positive trade balance. Investment in the high technology needed for the Space Exploration Initiative will maintain and significantly improve our share of the global market in technology and positively

affect our international balance of trade. *The Space Exploration Initiative is an investment in the future of America.*

Why Now?

America stands at the threshold. Our national space program is undergoing intense scrutiny. Many ask questions similar to those voiced during the heyday of Apollo — What is the point of large space ventures? How can we afford the great expenditures? What is the value of human presence in space?

Great nations have always explored and profited from new frontiers and territories. Space is the new frontier of the industrialized world in the 21st century. Benefits from space and the technologies needed to journey there become increasingly important in the next century. As Americans, we must ask ourselves what our role will be in human expansion into the Solar System: to lead, follow or step aside?

Thirty years ago, the politics of a bipolar world order compelled us to take up the challenge of space competition. The challenge we now face is no less compelling or significant in the new and emerging world order than it was at the height of the Cold War. The world has changed. We face not only leadership challenges, but economic and technological ones as well. The Space Exploration Initiative will restore America to its preeminence as the world's space leader.

A global consciousness is emerging on such issues as environmental and resource conservation. Problems are so massive, complex and time consuming that few of them are subject to a quick solution, regardless of the availability of resources. There is near universal recognition that the future of all nations depends upon high technology. The science and technology associated with the Space Exploration Initiative take us down avenues that converge on ways to deal with the world's problems. By

exploring space, we come to better understand both ourselves and our planet.

By offering direction and purpose, the Space Exploration Initiative will rejuvenate our sense of challenge, competitiveness, and national pride. The Space Exploration Initiative is a positive, social endeavor. In a world of uncertainty, it has the capacity to inspire people, to stimulate them, and to cause them to reach deep inside to find the very best they have to offer.

Technology development and architecture analysis must precede any final concept validation effort. The Initiative can be started now with a modest commitment of funds.

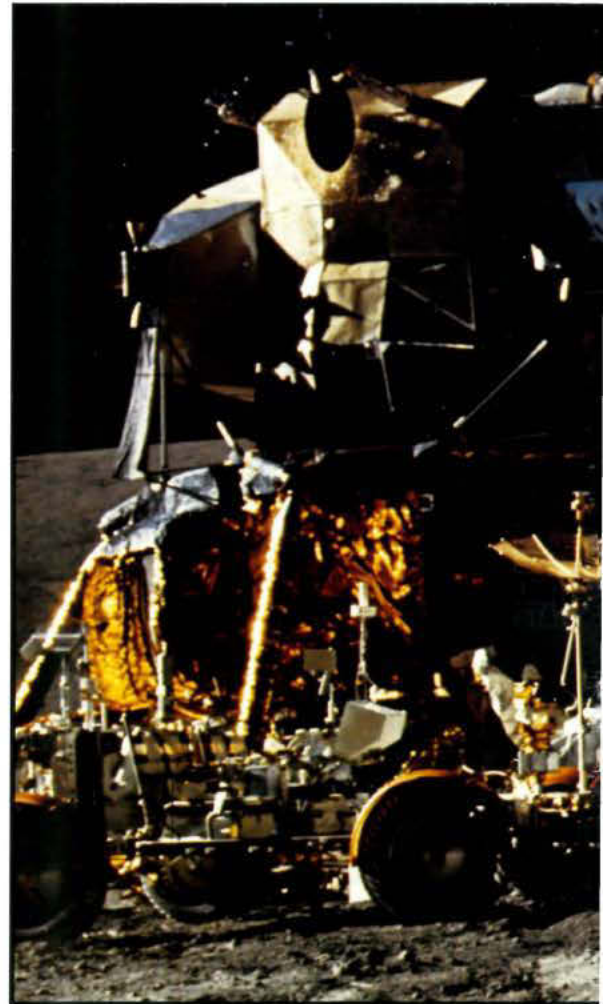

The Space Exploration Initiative is vital to the future of this nation. In this country's past, focused, goal-driven programs have a record of success and benefit to all humanity; we do not settle for less now.

"I believe without question that if a nation misses the great movements of its time it misses the foundation on which it can build the future. The high technical requirements for success in space are so fundamental that spin-off rewards are almost automatic . . . No one today can even guess the limits of either the personal items or the industrial which might accrue from the basic scientific work that has to be done in a space program. This is the great unknown ocean of the universe and we . . . are as obligated to probe it and use it and participate in its control as the nations of Europe were obligated to explore their terrestrial oceans in 1483.

I believe that there are moments in history when challenges occur of such a compelling nature that to miss them is to miss the whole meaning of an epoch. Space is such a challenge."

James A. Michener

Descartes Region of the Moon, Apollo XVI

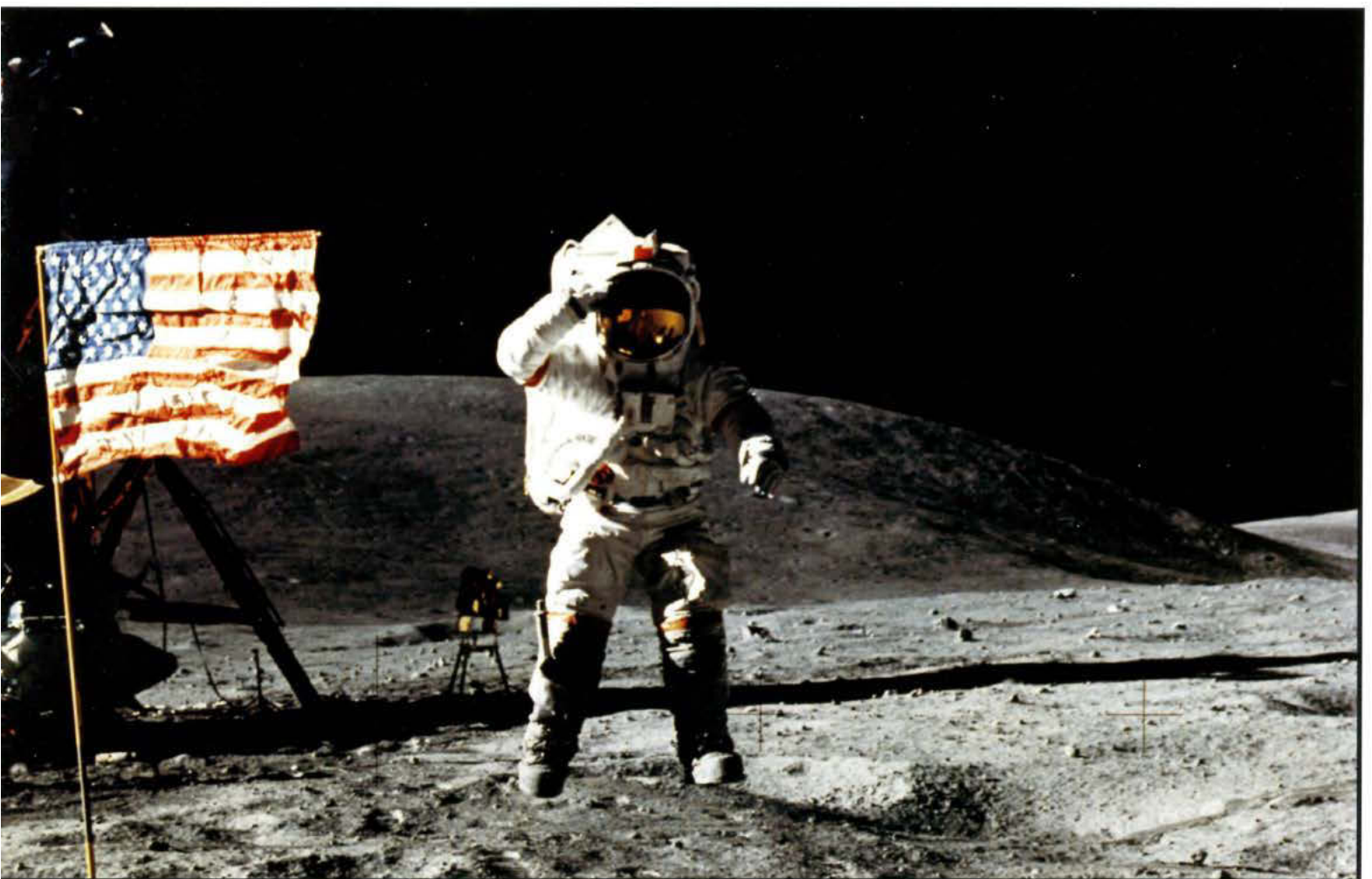

An architecture is both a set of objectives ordered to achieve an overall capability and the sequential series of missions (including specific technical activities) to implement those objectives. Subsequent sections of this chapter discuss the considerations and constraints affecting all architectures, the common elements across the architectures and the four architectures.

Commonality of Architectures

Although the architectures presented here differ, there are common aspects that relate to mission sizing, launch opportunities, duration and surface activities. The dates provided are estimates based upon the optimum launch opportunities for Mars. The dates are notional and depend upon available resources and technological development.¹ The target year for the first landing of humans on Mars, 2014, is common to all architectures, except Architecture IV. Architecture IV has a first landing in 2016. The year 2014 is chosen conservatively to allow for accomplishing the necessary system demonstrations and preparations on the Moon prior to attempting the challenging Mars mission. This also coincides with the opening of a 15-year synodic period of optimum low energy Earth-to-Mars missions. Missions to Mars are possible on 26-month intervals. Recognizing there can be program delays, the President's goal of a landing by 2019 is still possible with alternate Mars opportunities in 2016 and 2018. The synodic window starts to narrow in 2020. Although some flexibility is possible with the dates for lunar activities, they are selected in order to accomplish activities specified by individual architectures, and to properly certify equipment and procedures for the Mars mission in preparation for the initial launch date.

All Mars architectures are designed for a 30 to 100 day stay for the first mission and an approximate 600 day stay for subsequent missions. This

leads to total mission durations of approximately 500 and 1,000 days respectively. It is assumed that after the first human Mars mission, coupled with the experience gained on the Moon, confidence in systems and human capabilities will allow for longer duration missions. A crew of six was selected for both the Moon and Mars missions to achieve maximum commonality for equipment, crew tasks and procedures. For the first two piloted missions to the Moon, one crew member remains in orbit to perform inflight experiments and to monitor the orbiting vehicle while the other five descend to the surface. All six go to the lunar surface after sufficient confidence is gained that the orbiting vehicle remains in an acceptable status while unattended. At Mars, all crew members descend to the surface for every mission, as the reliability of the unattended vehicle has been verified around the Moon. This reduces the hazards associated with space radiation and prolonged time periods in zero gravity.

Architectural activities are described in terms of Initial Operational Capability and Next Operational Capability on both the Moon and Mars. These concepts are used for three reasons: to provide a point at which accomplishments to date can be meaningfully evaluated; to provide decision points at which a given program can be continued, modified, or stopped; and to let each mission contribute to the capability required to meet the next operating level in the sequence. After the lunar Initial Operational Capability in all architectures, a decision can be made to conduct the preparation-for-Mars lunar mission and then proceed directly to the Mars mission.

Diversity of Architectures

Architectures described offer diverse approaches, emphases and program scope and scale for the Space Exploration Initiative. From a the-

Architectures	
I.	Mars Exploration
II.	Science Emphasis for the Moon and Mars
III.	Moon to Stay and Mars Exploration
IV.	Space Resource Utilization

matic aspect, different architectures vary as to the degree of human presence in space, the level to which exploration and science are pursued, the extent to which space resources are developed, and the relative emphasis between lunar and Martian activity. Regardless of the primary emphasis of a given architecture, the other two emphases are always included, as shown below.

Time in lunar orbit to prepare for Martian missions varies from a total of 120 to 460 days, depending on the architecture. Although the 120 day stay time does not exactly duplicate the Mars transit time, it is felt that this time could be extrapolated with a high degree of confidence.

The use of the Mars transfer vehicle, in conjunction with a surface emplacement on the Moon, would allow mission-critical studies into the physiological effects of the fractional Earth-normal gravitation exposures following extended zero gravity stays. This objective can be accomplished with a high degree of operational fidelity on the Moon, and the ready access to zero gravity or fractional gravity would permit a rapid accumulation of data. Simulations of Mars gravity on the lunar surface, using a weighted spacesuit, would allow refinement of gravity-response curves.

The Mars transfer vehicle would have a number of other key missions in addition to life science activities, including simulations of Mars missions, complete with excursions to the Martian (lunar) surface and return, the use of an orbital platform for lunar or astronomical observations, and as a test bed for other essential Mars transfer vehicle subsystem development.

Considering the three different areas of emphasis and the variations in lunar and Mars activity, four architectures have been defined. The *Mars Exploration* architecture places an emphasis on Mars rather than on the Moon. Only activities absolutely nec-

essary to prepare for the Mars mission are planned for the Moon. However, this still allows for meaningful lunar scientific return as a byproduct. The second architecture, *Science Emphasis for the Moon and Mars*, explores both the Moon and Mars and uses the Moon as an observing platform with an integrated strategy of robotic and human missions. The third architecture, *The Moon to Stay and Mars Exploration*, emphasizes human presence on the Moon, with smaller crews engaged in exploration and science at Mars. This architecture is designed to establish a permanent presence for humanity on the Moon so that significant exploration and observation can be accomplished. The fourth architecture, *Space Resource Utilization*, emphasizes the development of lunar resources to provide energy for Earth and the production of propellants to be used for lunar launch and surface operations, and potentially for Mars.

¹ Norman R. Augustine, Chairman of the Advisory Committee on the Future of the U.S. Space Program, addressed the Synthesis Group. When asked what was meant by "go-as-you-pay" in the report, he answered that "The Space Exploration Initiative should be programmed to proceed at a schedule consistent with available funding and the establishment of a solid technology underpinning. When there are problems in the program, as there will always be, the schedule should be slipped rather than taking money from other smaller programs such as the research program."

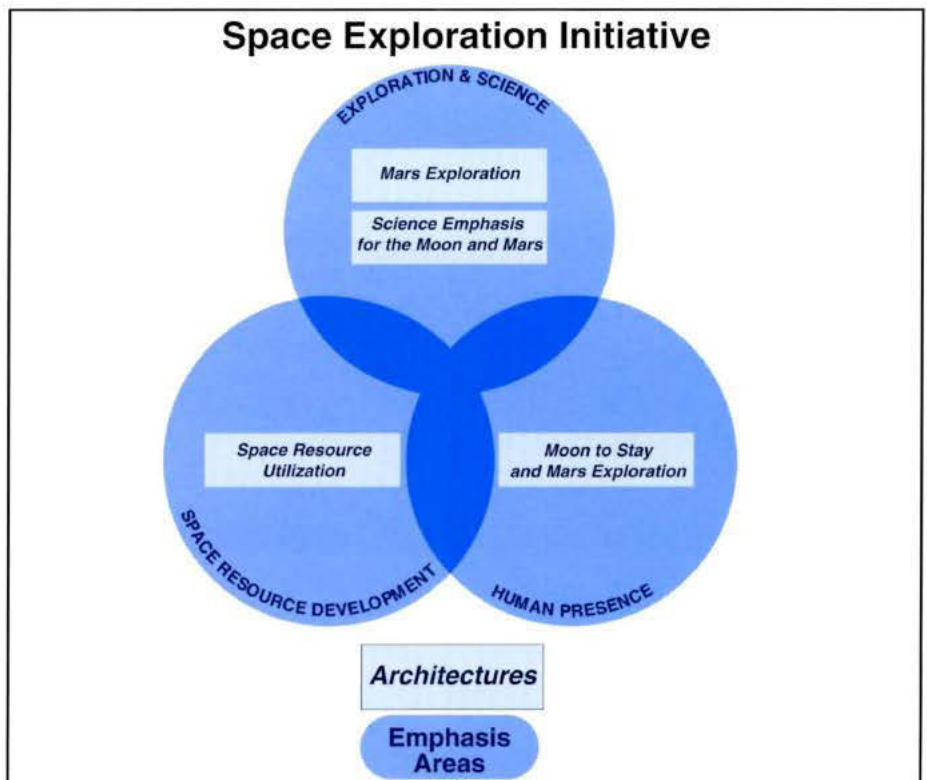

The Space Exploration Initiative architectures are based on the priorities of safety, cost, performance and schedule. This differs from the Apollo program priorities of safety, schedule, performance and cost. These priorities and the lessons learned from previous experience establish a philosophical baseline of specific concepts and ideas that are common to all Initiative architectures.

Crew Safety

Crew safety is the prime consideration for human spaceflight operations. Missions which include both long duration flight and planetary surface stays require system designs and operations concepts that maintain crew health and safety. Due to the communications delay on a mission to Mars, the crew will need to operate independently for critical phases. Mars missions require redundancy in system design and abort options. Propulsion systems, landers and habitat modules require reliable and redundant design to reduce vulnerability to failure.

The following principles were identified to ensure crew safety:

- Multiple levels of parallel redundancy with high reliability and low maintenance requirements
- Capability for both the crew and built-in systems to monitor and control all critical functions during normal and contingency operations without support from Earth
- Capability for the crew to manually control and override critical systems
- System designs which allow crew maintenance or repair
- System and consumable margins which reflect resupply rates

The Synthesis Group established mission abort principles for the architectures. Options were considered for each phase of the mission. While it is understood that establishing generic guidelines for abort strategy is difficult at best, basic principles are required to establish criteria for planning. The basis for all abort options is to reduce vulnerability to failure by system reliability and redundancy, and to provide flexibility to the mission commander to execute an abort mode if necessary (Table 1).

Essential functions must be tolerant to multiple failures and must be restorable. System design requires that the first failure results in no operational degradation; the second leaves the system operational, but possibly in a degraded mode; and the third leaves it in a safe and restorable configuration. Thus, the third failure is not catastrophic and the time to restore the function, at least to a degraded operational mode, is less than the time leading to an irreversible catastrophic condition.

Table 1

Phase	Abort Principles
Enroute To Moon	Reduce Vulnerability to Failure by System Reliability and Redundancy Provide Trans-Earth Injection Fuel or Use Free Return Trajectory
Enroute To Mars	Reduce Vulnerability to Failure by System Reliability and Redundancy Provide Trans-Earth Injection Fuel
Moon and Mars Orbit	Reduce Vulnerability to Failure by System Reliability and Redundancy
Ascent/Descent To/From Surface	Reduce Vulnerability to Failure by System Reliability and Redundancy Provide Both Abort to Surface/Orbit and Options to the Commander
Planet Surface	Reduce Vulnerability to Failure by System Reliability and Redundancy

Mission Opportunities

In order to understand the complexities of interplanetary spaceflight, certain terms must be explained. These terms are:

Engine Specific Impulse: Expressed in seconds, the engine thrust in pounds divided by the propellant flow rate in pounds per second.

Thrust-to-Weight Ratio: The ratio of the engine thrust to the engine weight.

Delta-V: Transportation systems to the Moon and Mars require a series of propulsive maneuvers which result in a velocity change for the spacecraft. This velocity change is called delta-V, expressed in units of velocity (km/s) and related to the amount of energy, and thus fuel, that a spacecraft requires for a mission.

Initial Mass in Low Earth Orbit: The total mass, fuel, transfer vehicle, lander, etc. placed in low Earth orbit to accomplish a space mission.

When Apollo crews went to the Moon in the late 1960s and early 1970s, they accomplished the mission in the following phases:

- Earth to orbit
- Earth orbit operations
- Trans-lunar operations
- Lunar orbit operations
- Descent to surface
- Surface operations
- Ascent from surface
- Lunar orbit operations
- Trans-Earth operations
- Earth entry

The total delta-V for the trip was 5.6 km/s from low Earth orbit to lunar orbit and back. It took three

days to travel the 400,000 km from the Earth to the Moon.

The Earth orbits the Sun once every 365.25 days in a nearly circular orbit with a radius of 149.5 million kilometers. The mean speed of the Earth relative to the Sun is 30 km/s. Mars, on the other hand, orbits the Sun every 686.79 days (1.88 Earth years) in an elliptical orbit with an eccentricity of 0.1. Although the mean distance from the Sun is 227.8 million kilometers, the eccentricity of the orbit results in a 20% difference in distance from the Sun at the two extremes of the orbit; the Mars orbital speed varies between 22 to 26 km/s. Further complicating matters is the fact that the orbital planes of Earth and Mars are inclined relative to each other at 1.9 degrees, rather than being co-planar.

With the difference in orbital periods, "similar" launch opportunities occur only once every 26 months. A similar launch opportunity is one in which the planets have the same heliocentric angular orientation, or phase angle, relative to one another, as shown in Figure 1. However, the eccentricity in the Martian orbit, combined with the orbital speed differences between Earth and Mars, mean that exact launch cycles repeat only once every 15 years. Even though the same phase angle for a launch opportunity for a given mission occurs every 26 months, the distances between the planets and their relative speeds are different, which lead to different energy requirements and trip times from one opportunity to another.

The phases of the Mars mission are:

- Earth to orbit
- Earth orbit operations
- Trans-Mars operations
- Mars orbit operations
- Descent to surface

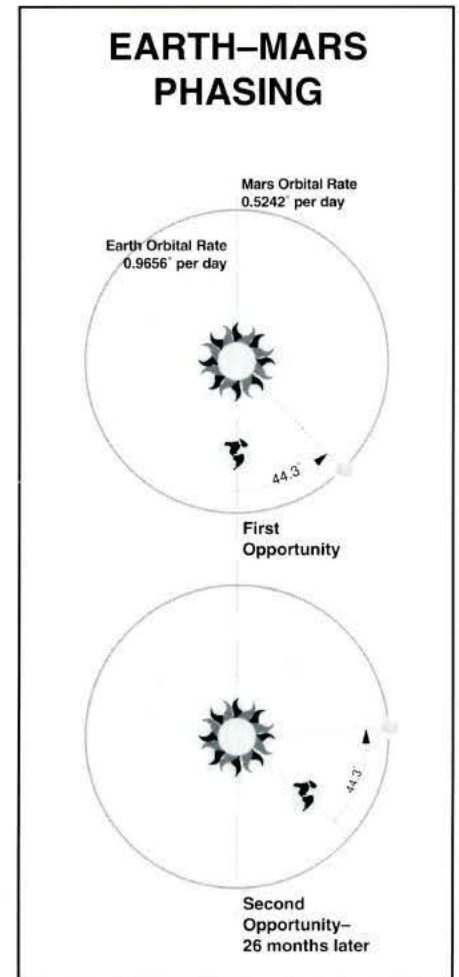

Figure 1

- Surface operations
- Ascent from surface
- Mars orbit operations
- Trans-Earth operations
- Earth entry

The delta-V requirements for the trip from low Earth orbit to Mars orbit and back vary from approximately 8.2 km/s to 24 km/s, depending on the launch opportunity.

Mission Duration

Missions to Mars fall into one of two classes: long duration missions (conjunction class) and short duration missions (opposition class). A long duration mission trajectory traverses a heliocentric angle of about 180 degrees during each orbital transfer, with tangential departure and arrival, as shown in Figure 2. The transfer trajectory, known as a Hohmann transfer, is the minimum energy orbital transfer. This mission duration is on the order of 1,000 days, with a typical stay time at Mars of approximately 500 days. The delta-V

requirements for long duration minimum energy missions are fairly constant, varying only about 10% over the 15 year cycle.

Short duration missions are on the order of 500 days total trip time, with a 30 to 100 day stay at Mars. One of the transfer legs, either the outbound or inbound, must have a deep space propulsive maneuver. This maneuver can be replaced with a Venus swing-by, which is more efficient from a propulsive energy requirement, but requires that Venus be in a particular phase with both Earth and Mars. The Venus swing-by uses Venus’s gravity to modify the trajectory and shorten the trip time and reduce the delta-V. Due to a combination of the eccentricity and the inclination of the Mars orbit, the delta-V requirements for short duration missions can vary with launch date by as much as a factor of two. The best short duration mission opportunities occur in 2003 and 2018. The transfer legs of a typical short duration mission are shown in Figure 3.

There are two major propulsion options for the Mars missions: chemical and nuclear. Both options are compared in Figure 4 for the 2014

Figure 2

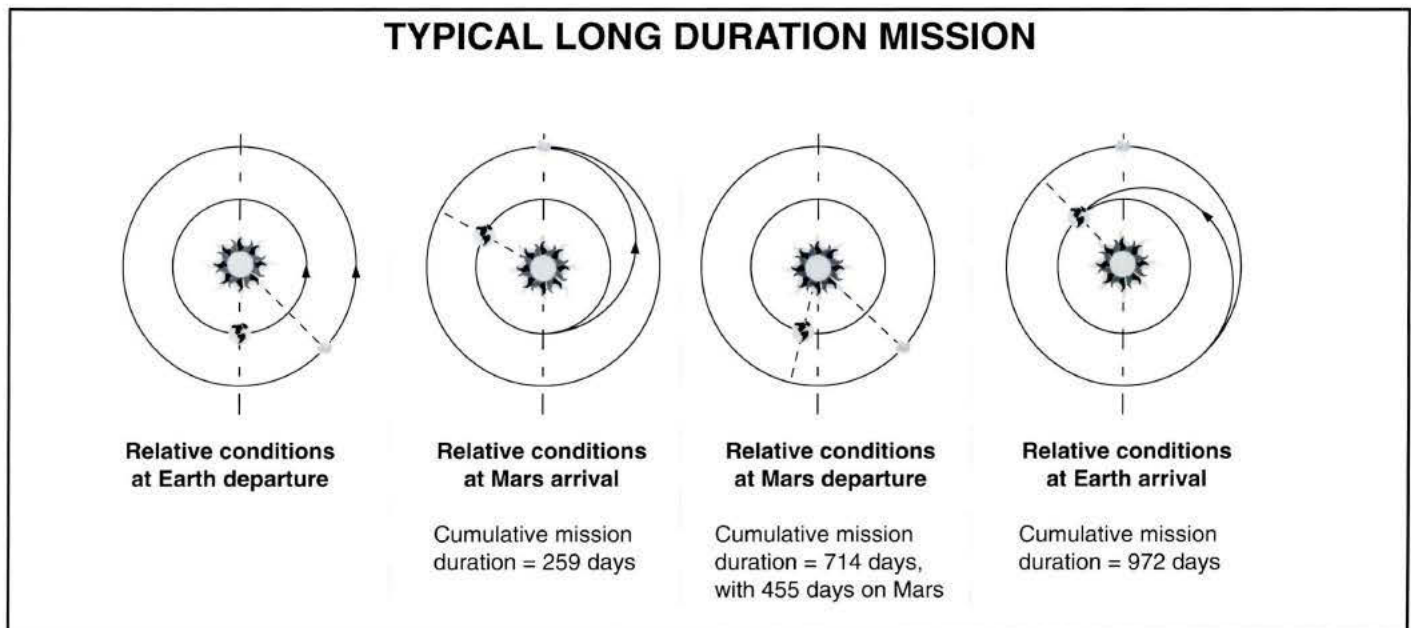

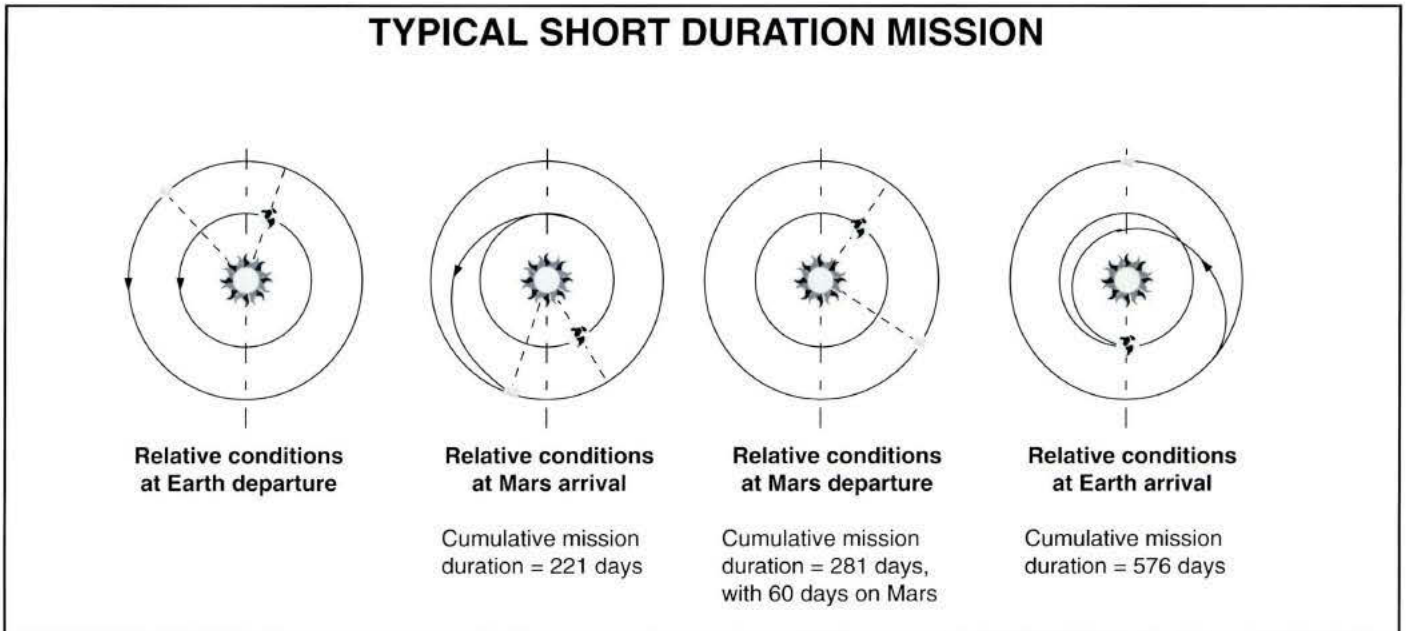

Figure 3

opportunity. Chemical systems have the advantage of being a well developed, flight-tested technology. Unfortunately, chemical systems are limited in performance, with large propellant mass requirements in low Earth orbit and major restrictions in launch opportunities. Nuclear systems, on the other hand, promise high performance with significant savings

in propellant mass. Although nuclear thermal rocket technology was demonstrated in the 1960s, it has not been flight tested.

Launch costs are heavily dependent on the required initial mass in low Earth orbit. Therefore, cost constraints tend to lead toward mission configurations with lower delta-V requirements, and correspondingly

Figure 4

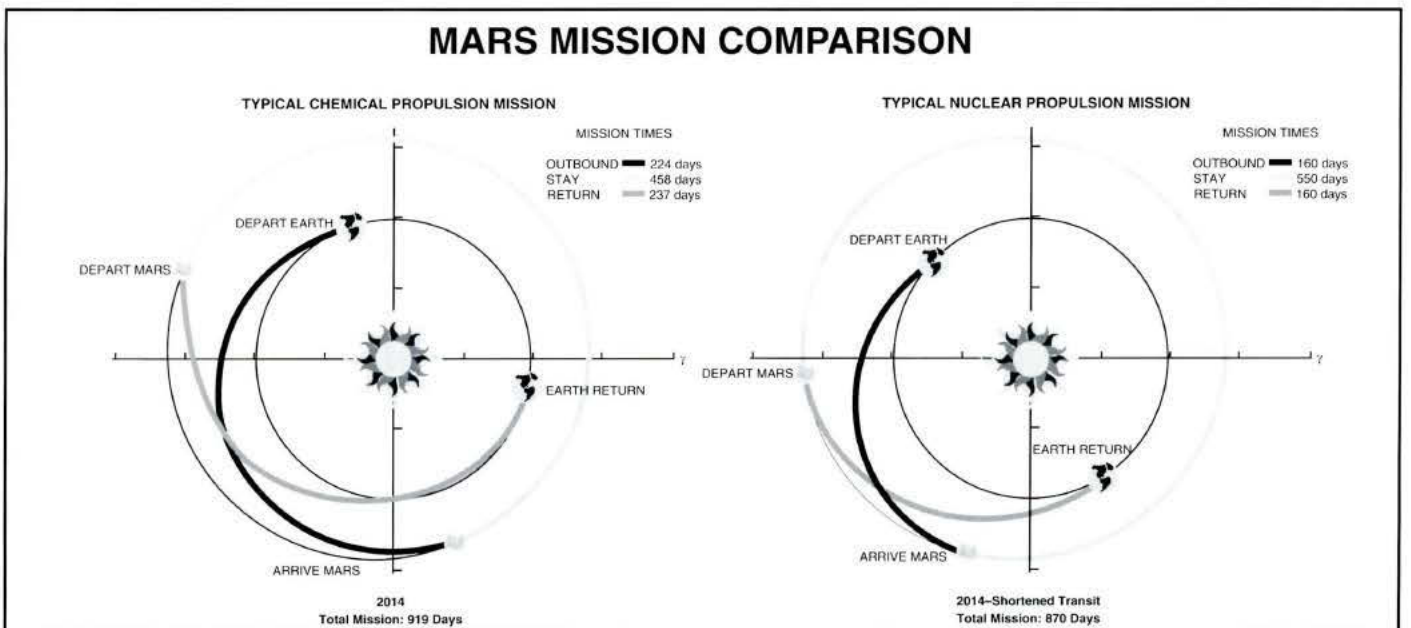

extended from 30 to 100 days at an increase of 100 to 200 metric tons in the initial mass to low Earth orbit during favorable years.

The total number of launches per mission would be limited by the need to minimize on-orbit assembly and at the same time meet available launch windows. For example, using a heavy lift launch vehicle with a 250 metric ton payload capacity, and operating with a maximum system linkup capability of three launch modules, the initial mass to low Earth orbit needed for a total trip would be limited to a maximum of 750 metric tons. Volume constraints and spacecraft design considerations may apply additional limitations. These types of practical limits were considered in evaluating potential missions.

Space Radiation

The space radiation environment outside the Earth's magnetosphere is composed of two types of radiation which present a potential health haz-

ard: galactic cosmic and solar flare events.

The galactic cosmic radiation environment is reasonably well known, yet there are uncertainties with respect to biological effects and related risk assessment. The allowable annual radiation exposure for the astronauts' blood forming organs is 50 REM — a dose of radiation called "Radiation Equivalent Man." During the Mars transfer, the unshielded radiation dose rate will range between 24 and 60 REM per year as a function of the solar cycle (galactic cosmic radiation is maximum during solar minimum). The expected galactic cosmic radiation dose received by an unshielded astronaut on a trip to Mars is below the allowable amount based on the annual 50 REM limit adopted for Space Shuttle astronauts. Shielding to reduce the highly penetrating galactic cosmic radiation is impractical, due to the enormous weight penalty that must be paid to shield the entire spacecraft. Selective materials integrated into the spacecraft design, however, can reduce the

Figure 6

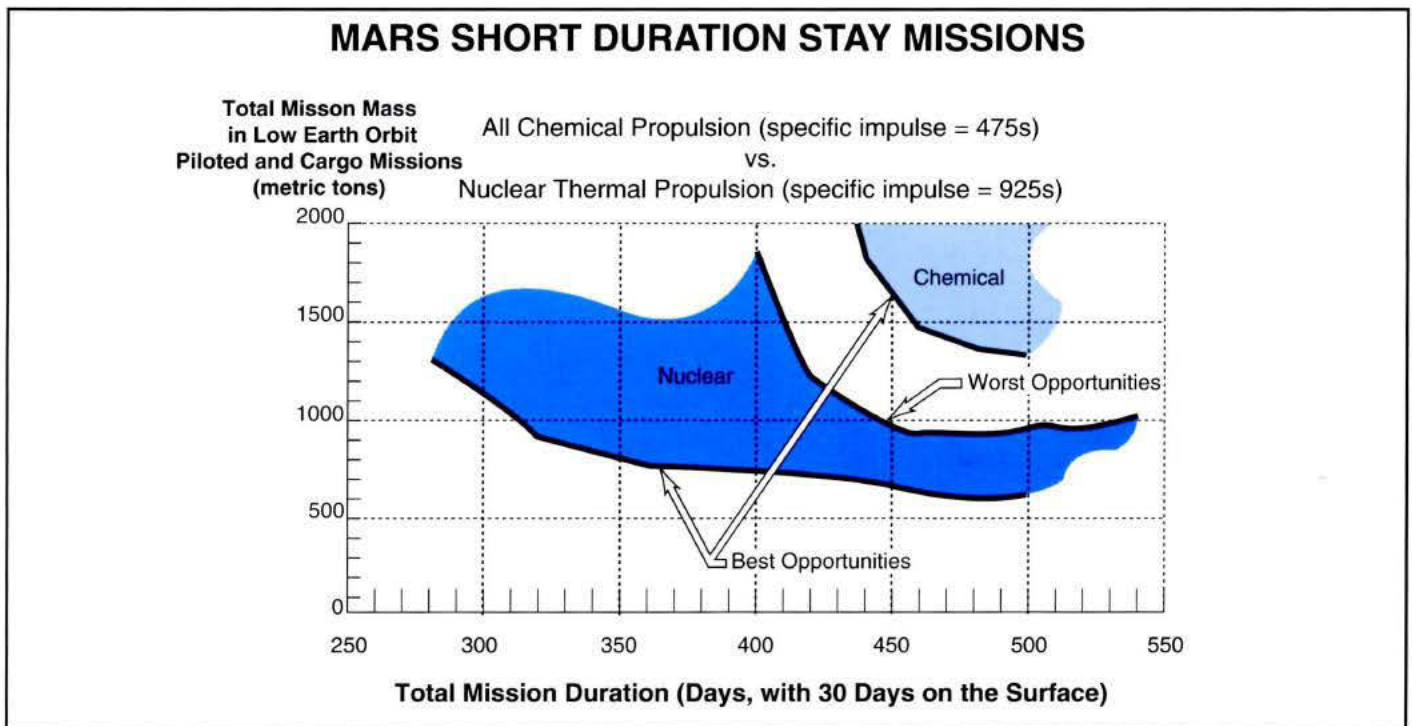

radiation effects. Reducing the trip time is the best method to limit the galactic cosmic radiation exposure to the crew. Once on Mars, the planet and atmosphere provide adequate protection.

Solar flare events may be incapacitating or lethal for an unshielded astronaut; however, the short duration and the energy spectrum of solar flare events (lower than the energy spectrum of galactic cosmic rays) make radiation storm shelters an effective countermeasure. The mass penalty for shielding can be reduced by using water for passive shielding. The excess water required will also enhance safety by providing a backup to water loop closure systems. A radiation storm shelter with 16 gm/cm² of water is estimated to provide adequate shielding against anomalously large solar flare events. Solar monitoring satellites and observations from Earth will enable long range predictions of solar flare activity for mission and extravehicular activity planning purposes. In addition, onboard radiation monitors will provide real time warning to alert the crew to seek the shelter during an event.

Biological experience gained from operations in the lunar environment, along with passive radiation shielding and reduced trip times, should provide adequate protection to the crew for the Mars missions.

Zero Gravity

The issue of mission duration is central to the discussion of architectures. Within the context of the proposed exploration missions, there are several distinct gravitational environments. Extended stays on the lunar surface will result in exposure to one-sixth the Earth's gravity. Mars missions will entail exposure to zero gravity during the outbound leg, three-eighths the Earth's gravity during surface stays of 30 to 600 days, and zero gravity during the return trip. Human exposure to zero gravity results in a deconditioning process, which is related to the time spent in the reduced gravitational field.

The existing knowledge base for deconditioning from long term zero gravity exposure consists of Skylab data, up to 84 days duration; and Soviet Mir space station data, with up to 366 days duration. These experiences, to be confirmed with additional research, indicate that with appropriate countermeasures, a crew can be maintained in satisfactory condition throughout long duration flights; therefore, artificial gravity is not incorporated in the four architectures. It is expected that while crews are on the Martian surface, the three-eighths Earth's gravity will help maintain their physiological health.

It is necessary to fully understand deconditioning effects in order to ensure

that Mars missions are conducted in a safe manner. The approach recommended involves crews using a Mars transfer vehicle crew compartment in lunar orbit and then descending to the lunar surface to provide simulation for Mars missions. This would allow

rapid accumulation of adaptation data. This simulation capability will be used to develop and test effective countermeasures. Mars missions will be designed to minimize, to the degree possible, the time spent in zero gravity.

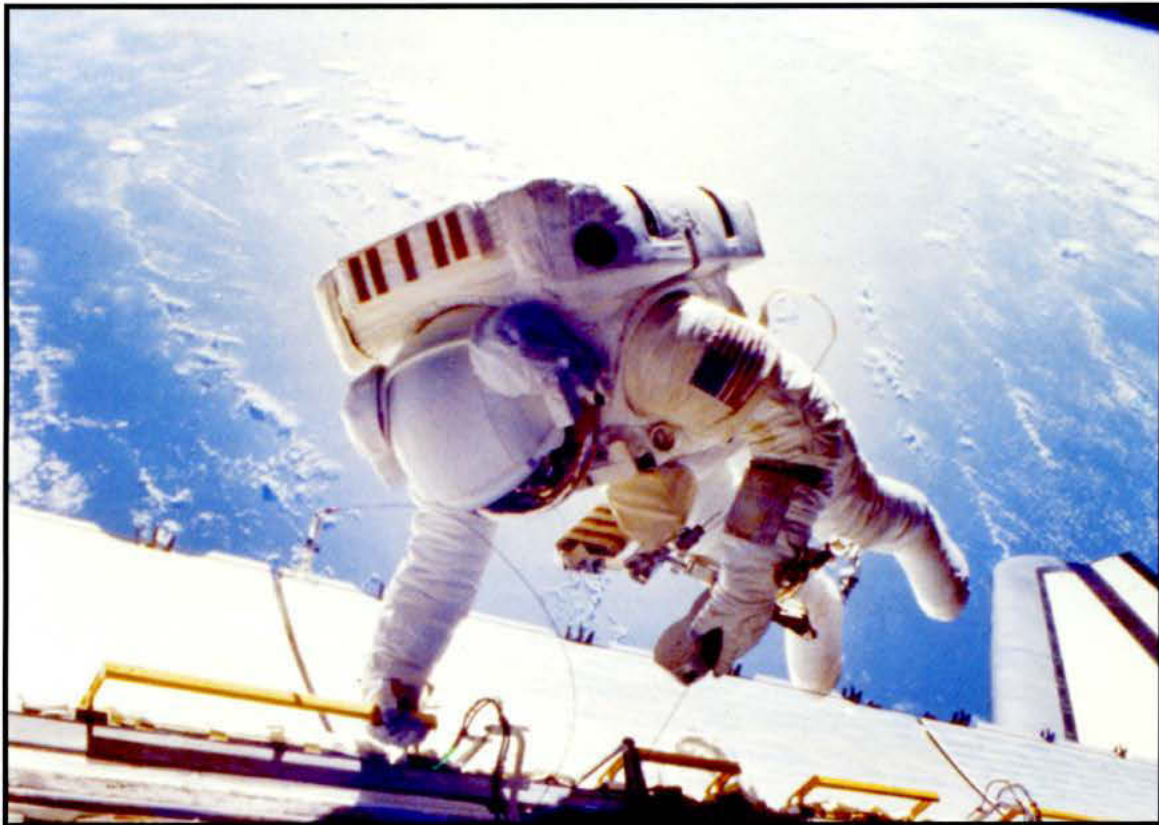

Astronaut Working in Zero Gravity

The journey to the Moon and Mars will consist of many different activities, both on planetary surfaces and in orbital and interplanetary flight. The common architectural strategies are shown below.

Common Architectural Strategies

- Involve the public in the adventure of exploration
- Provide for significant science return
- Emphasize educational return
- Encourage and facilitate benefits for commercial applications and for the industrial sector

Lunar Surface Activities

Surface activities at the Moon encompass the three primary components of the Initiative: science and exploration, human presence, and space resources. In each activity, specific tasks, equipment and strategies are employed to accomplish mission objectives. Not all activities are undertaken at once; the relative extent of each activity is partly responsible for the diversity of architectures.

The Moon is an important target for scientific investigations, both as an object of study and as a platform to look upon the universe. The Moon has undergone a complex and protracted geologic evolution, including the formation of a crust and mantle, impact bombardment, flooding of the surface by volcanic lavas and deformation of the crust by fracturing. The lunar soil (regolith) contains a four billion year history of the output of the Sun. The craters of the Moon record the variations in the impact flux in the Earth-Moon system. The complexity and richness of the lunar geologic record can be deciphered to give us an unprecedented view of the origin and evolution of the Earth-Moon system.

With its low gravity, vacuum and long nights, the Moon is an excellent site from which to observe the universe. It is a stable platform where delicate astronomical instruments can be emplaced and operated to give detailed views of our own and neighboring star systems. Moreover, the observation instruments can scan the entire electromagnetic spectrum from the lunar surface. Observatories on the Moon will give us incomparable views of the universe and Earth and new insights into their origin and evolution. For the first time, it will be possible to resolve the apparent disks of individual stars and observe star spots; such resolution may also permit imaging of other planetary systems. For extra-solar planets, surface features of Jupiter-sized planets can be mapped while full disk spectra of Earth-like planets can be obtained.

The Moon is a source of both materials and energy for an emerging space-based economy in the 21st century. The lunar regolith contains absorbed solar light gases (e.g., hydrogen) and indigenous oxygen that can be extracted and collected for use as propellant and for life support. The regolith also serves as a source of ceramics and metals for construction on the Moon and in Earth-Moon space; iron, titanium and aluminum are relatively abundant. Bulk soil can serve as radiation shielding for surface habitats. Solar power is constantly available during the lunar daytime (14 Earth days). Finally, the rare isotope Helium-3 is present in the lunar soil; this material may ultimately power terrestrial fusion reactors in the next century, providing clean and safe electrical energy.

The Moon is a place for humanity to live and work in the 21st century. It is a small planet with natural, reduced (1/6) gravity; in total area, the Moon is roughly equivalent to the continent of Africa. The materials and energy needed for human habitation on the Moon are readily extractable from surface materials. The Moon is

only three days from the Earth and the near side has a constant and psychologically reassuring view of our home planet. It is a natural "space station" orbiting planet Earth.

Lunar missions and preparations are essential prior to accomplishing piloted missions to Mars. Without flights to the Moon, more than 40 years will have passed since the latest piloted mission beyond low Earth orbit. The Moon is relatively accessible and return to Earth is readily accomplished (as compared to a Mars mission) if emergencies occur. The topography and environment of the Moon are used to simulate Martian conditions. As a part of this approach, it is important to test and operate the actual equipment and systems to be used for the Mars mission. The only way to prove that equipment and systems are truly reliable is to test their functions and operate them over long periods of time in realistic environments.

The Moon provides a testing environment of human performance to ensure the safety of the crew. The issue of human performance after long exposure to zero gravity, and the effectiveness of countermeasures to long term exposure to zero gravity, must be well understood before sending crews to Mars. The degree of autonomy required in systems and equipment is better assessed after understanding crew adaptability to a reduced gravity environment. Simulations of human stay time are required between time spent on the lunar surface and in space-based facilities. Human adaptation at the Moon is measured after spending sufficient time in reduced gravity. Crew members adapt in facilities on the Moon, performing tasks similar to those required at Mars. These crew members also experience the psychological effects and isolation that are experienced by crews traveling to and from Mars. Operational concepts are developed to make best use of the systems and crew on the planetary surfaces.

This applies to robotic and telerobotic systems, as well as human activities.

Martian Surface Activities

The exploration of Mars involves several scientific disciplines that deal with the study of Martian origin, geological processes, and evolution. All architectures envision a robust Mars exploration program that consists of complementary robotic and human mission elements. The exploration program is designed to give first-order answers to some of the most fundamental questions of planetary science.

Scientists are interested in the geological, climatological and biological processes that now act or have acted in the evolution of Mars. Mars has a complex history, involving impacted projectiles from space, internally generated magmas that both intrude the crust and spill out on it (volcanism), tectonic forces that deform and fracture the planet's surface, and erosion and deposition by wind, water and ice. Geological processes that have shaped all the terrestrial planets have acted to one degree or another on Mars.

Although Mars is currently cold and has a very thin atmosphere, it is believed that conditions were much more Earth-like several billion years ago. At that time, Mars apparently had a thicker, warmer atmosphere, running water, and a more moderate climate. Because these conditions could have supported life, the search for traces of former Martian life (fossils) is an important objective in the exploration of Mars.

For some reason, the benign Martian climate changed; the atmosphere thinned, temperatures cooled, and the existing surface water either sublimated into the atmosphere and was subsequently lost to space, or became frozen as ground ice. Why this dramatic change occurred is one of the major puzzles of Martian history. Moreover, it may be a cautionary

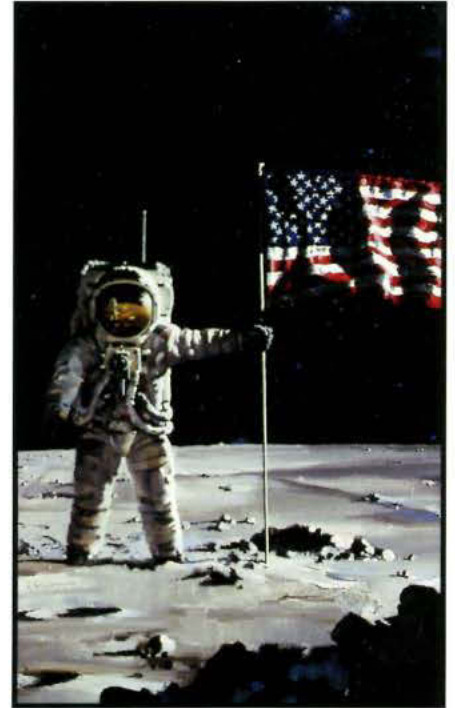

American Exploration

tale for Earth-dwellers, since the dynamics of global climate change are as poorly understood as they are life threatening. With the concerns over Earth's global warming and the long term effects of pollution on the environment, the history of Mars holds valuable insights that will assist in understanding and improving the Earth's evolving environment. Studying Mars also helps in understanding planetary processes and formation and in understanding the history of the Solar System. The exploration of this planet millions of miles from the Earth complements the efforts of Missions to Planet Earth and could hold a key to understanding our own planet.

Surface Science Activities (100 days)

The arrival of humans on the surface of Mars opens new vistas of scientific accomplishment. Field studies become possible when human powers of observation and thought are present, both through the actual presence of humans and by extension through telepresence, the projection of some human powers of discernment and cognition through a machine.

Each mission carries a pressurized rover, giving the crews access to areas within a 50 km radius of the landing site for the first flight, increasing to a 100 km radius in subsequent missions. Because they will have been preceded by a robotic surface rover, the crew's first task is to thoroughly characterize the landing site environment within a radius of 2 km.

Detailed field study of the geology of this area is an ongoing task of the crew members remaining behind while others conduct rover traverses. Experiments are performed on a small scale to test the feasibility of producing fuel from local resources and to demonstrate the capability to grow food in the habitat.

Traverses in the pressurized rover are to sites identified from orbital imagery and the prior surface rover reconnaissance. A crew of two or

three travels to examine key geological sites, collect carefully controlled samples, deploy instrument packages and decipher and understand the complex geology of the region adjacent to the landing site. Although general routes are planned and major field sites identified in advance, the unique opportunity of human travel over the Martian surface permits traverse routes and plans to be modified in real time. This capability is the cornerstone of conducting true field exploration, and the maximum possible latitude for operational changes is granted to the crews during the Mars visit. In this way, significant discoveries are most likely to be made and, as important, followed up with additional field work.

As an example, a landing site might be selected adjacent to certain smooth deposits contained within the floor of the Martian canyons; studies have suggested that these deposits represent ancient lake sediments. A site reconnaissance orbiter documents the geologic relations and context of these deposits in some detail and a pre-deployed surface rover obtains data on their surface composition and physical properties, including a search for outcrops and other exposures.

It is left to the crew to examine these deposits and perform geologic field work. This consists of systematically examining, measuring and sampling exposed lake deposits, mapping their extent and continuity, and searching the rock exposures for possible fossil remains. The field work proceeds on both a contingency and an iterative basis. In the first case, the crew's specific field tasks are actively directed by significant findings in the field; these decisions are made by the field crew in real time. In the second case, the crew has the ability to revisit, re-examine and re-sample previously explored field sites, both to supplement new knowledge and to place data into new contexts derived from the evolving conceptual framework. Such work requires insight and geo-

logical experience and it constitutes a major contribution by humans to planetary exploration.

Surface Science Activities (600 days)

Additional science opportunities are presented by a long surface stay capability. Although the general character of field exploration on a long-stay mission is similar to that conducted during a short stay, more thorough field science of the selected site is accomplished. Return in planetary science is directly proportional to access, capability and time. A significant increase in the amount of time available greatly increases the science return of the mission. Time is available to completely characterize the area surrounding the landing site within the traverse radius of the pressurized rover. An important aspect of extended time on the surface is the ability to revisit sites. Such activity is very common in terrestrial geology and permits the field testing of hypotheses that characterize advanced geologic study.

In order to take scientific advantage of extended surface stays, it is necessary to be able to do some first-order analyses of collected Martian materials in the habitat. This small-scale sample analysis laboratory is able to make bulk chemical analyses, rock examination under microscope and compositional analyses of volatiles, including gas and ice. These laboratory functions enable site revisits to have maximum effect, as field geology requires laboratory work interspersed with field collection. Cryptic or subtle properties of the samples hold significant clues to geological evolution, especially in the fields of ancient environment reconstruction and the search for fossil life.

Environmental and meteorological measurements assume increased importance during long stays, as the increased surface time takes the crew through an entire Martian year. Seasonal variations are studied from the surface in great detail; such

knowledge is also important in order to protect the crew from possible detrimental environmental effects (e.g., dust storms).

Difficult scientific problems, such as the search for fossil life or understanding ancient climates, require large amounts of time to gather data, understand field relations and reconstruct processes and history. Such problems are particularly amenable to study during long duration missions. While positive results from such an investigation cannot be assured, the chances for definitive answers are much more likely to be derived from extended surface activities than from short stays.

Science investigations on later missions will likely be configured to take advantage of the knowledge derived from the initial visits and will carry additional equipment or capability designed to increase the information return of surface exploration. It is unlikely that the general problems of climate change and the origin of life will be resolved during the first visits. These questions are deemed of great significance and will probably receive attention during any long range exploration plan. To fully address all these questions, many sites would have to be visited, sites that span the range of geological age and diversity evident on the planet's surface. Such access is achieved directly from Martian orbit, or from long range surface travel. The baselined method of surface travel offers the maximum flexibility to the crew to modify exploration plans in real time to accommodate discoveries likely to be made as the surface exploration progresses.

It is possible to greatly increase the science return from Mars exploration through the use of telepresence robots. Such robots permit human presence at many varied and separate sites without the logistic difficulties of physically transporting cumbersome life-support systems. In this operational concept, multiple robots are deployed at widely separated locations



Martian Surface

on Mars. These robots are controlled by human operators from a central site either on Mars, near the landing site, or from Martian orbit. Extensive field work is conducted, instruments are deployed and samples are collected by these machines under human control. Samples and data are collected at centralized locations for transport to the Mars habitat for first-order analysis and ultimately, to the Earth-return spacecraft.

Orbital Activities

If the crew were unable to land and were forced to remain in Martian orbit, a variety of scientific activities would be possible. Orbital science roles for humans fall into three broad categories: operators of instrument platforms, scientific observers in orbit, and participants in surface exploration by means of robotic telepresence.

Orbital instruments are an integral part of the global reconnaissance of any planetary body. Global observations from orbit are largely accomplished by robotic precursor missions. An instrument platform could be built into an orbital vehicle and operated in Mars orbit under direct human supervision, but it has not been baselined. This operation involves instrument cycling, repair and manual contingency operation. The value of humans as instrument operators was demonstrated during Apollo lunar orbital operations, again during the Skylab program and on numerous shuttle flights.

Direct visual observations from orbit allow the crew to examine terrain selectively, identify important or critical elements and decipher or unravel complex geological or meteorological phenomena in near real time. The resolution of direct observation is partly altitude-dependent and is augmented by optical devices (e.g., telescopes). The key factor is the human ability to synthesize disparate data to obtain new geological insight. As an example of how this

might happen, the famous orange soil discovered on the Moon by Apollo 17 was little more than a geological oddity until the geologist astronaut recognized regional deposits of orange soil from orbit. Our understanding of the significance of both the samples and its regional extent increased greatly through this direct observation from orbit; we now know that orange soil represents a major phase of volatile-rich lunar volcanism in this region around three billion years ago. Thus, significant clues to planetary geologic evolution may be uncovered through the use of human observations from orbit. Depending upon orbital parameters it might also be possible to conduct scientific observations of the Martian moons, Phobos and Deimos, as well.

The concept of telepresence depends on nearly instantaneous response between the human control operator and the slave robotic system. Orbiting vehicles maintain distances of a few hundred kilometers from the planet's surface, permitting true telepresent operation of robots on Mars by human controllers in orbit. Thus, orbiting crew members become active participants in surface exploration. These telepresent robots act in direct cooperation with the surface crew, as an extra member of the field party or as an independent explorer. In the latter case, the robot makes periodic returns to the surface lander to discharge its cargo of collected samples and stored data not directly transmitted to orbit. This telepresence mode of surface exploration not only greatly extends human reach, by accessing areas either too distant or inaccessible by the surface crews, but also provides a back up capability for surface field work by putting human "presence" on the surface, possibly under conditions in which humans could not effectively operate (e.g., abort conditions, dust storms). This third type of human activity from orbit greatly

augments the total scientific capability of the Mars mission.

Transportation

A heavy lift launch vehicle is the basic capability needed to support any lunar and Martian architecture. The Apollo Saturn V launch vehicle had a lift capability of 140 metric tons to low Earth orbit. This provided a very constrained payload capability to the lunar surface. The Space Exploration Initiative architectures require a more robust system. This has been provided for, in part, by having separate cargo and piloted flights. The mass to low Earth orbit requirements range from a minimum of 150 metric tons up to 250 metric tons per launch. Vice President Quayle asked that we investigate options to accomplish America's exploration goals faster, cheaper, safer and better. This investigation has led to the very clear conclusion that to achieve these goals, the utilization of a heavy lift launch vehicle having a capability to launch 250 metric tons to low Earth orbit is required. The heavy lift launch vehicle significantly affects the ability to implement the architectures defined. All of the lunar and Mars architectures have been baselined with such a vehicle. This allows the architectures to be clearly done faster, cheaper, safer and better than with a less capable launch vehicle. They could be done with a vehicle capable of only 150 metric tons. However, more launches and assembly in Earth orbit would be required, all at odds with the desired goal. A greater lift capacity will require fewer launches to support any architecture, and offers more operational flexibility when launching cargo and piloted missions in the same year.

The need for a new heavy lift launch vehicle has paved the way for an infusion of launch vehicle technology through the joint NASA-Department of Defense National Launch System Program. Many improved



Saturn V Launch of Apollo XVII

production and processing techniques have been identified. These improvements should be incorporated in the contemplated heavy lift launch vehicle. The lessons and the proven technology of the past must also be considered (e.g., the liquid oxygen-kerosene F-1 engines used for Apollo Saturn V, first stage). This combination of propellants and engines offers great potential for the first stage and boosters of a new heavy lift launch vehicle. These engines demonstrated a sea level

thrust of 1.8 million pounds per engine. Flight engines have a flawless record of performance for 13 flights with 65 engines. The propellants also offer the advantage of having less explosive potential by a factor of six than that of liquid oxygen-liquid hydrogen. There are no environmental issues associated with their CO_2 and H_2O by products.¹

In addition to a heavy lift launch vehicle, all architectures require the capability to dock elements of the lunar and Martian cargo and piloted vehicles in low Earth orbit. Automatic docking of modules, a technique utilized by the Soviets on a regular basis, is required. These operations preclude the need for extensive extravehicular activities in low Earth orbit to assemble lunar or Martian transfer vehicles.

Lunar Missions

A typical lunar mission begins with the launch to low Earth orbit of a

Heavy Lift Launch Vehicle

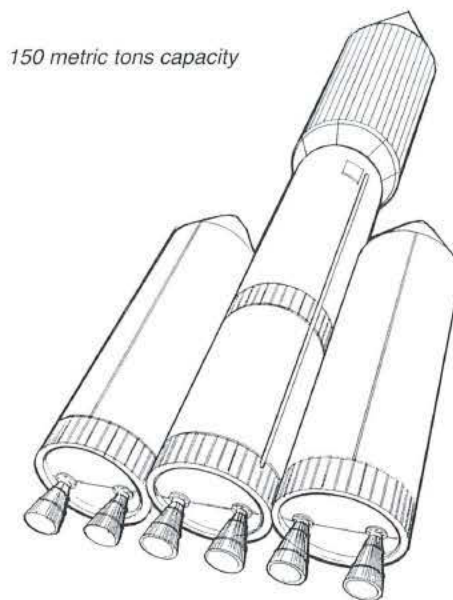

150 metric tons capacity

Technical Strategies

- **Develop a heavy lift launch capability**
- **Limit on-orbit assembly**
- **Develop nuclear technologies**
- **Use the Moon as a test bed in preparation for Mars**
- **Use common systems and operations between the Moon and Mars**
- **Use a complementary mix of human and robotic resources**
- **Emphasize technologies with terrestrial applications**

cargo vehicle containing a habitat, surface power supply, unloader, consumables and experiments. It is launched on a heavy lift launch vehicle with the lunar transfer vehicle injecting the cargo into the trans-lunar phase. Upon lunar approach, the lunar transfer vehicle provides an orbital propulsive capture maneuver to place the cargo and its lander into a lunar orbit. The cargo is then placed at a preselected landing site with the lander. Like the Apollo program, an all-chemical propulsion system is used for lunar missions.

The lunar cargo mission is followed by the piloted mission, containing consumables and experiments, as well as a rover. After launch to low Earth orbit, they are injected into a lunar trajectory by the lunar transfer vehicle, identical to that used for the cargo mission. A propulsive maneuver places the vehicle in lunar

orbit. A piloted lander provides a propulsive descent to the surface.

Upon the completion of their stay on the lunar surface, the crew returns to the lander for launch and rendezvous with the lunar transfer vehicle. A propulsive maneuver is accomplished to place the crew on a course returning to Earth. The crew makes a direct entry into the Earth's atmosphere using an Apollo-type command module.

Mars Missions

The typical Mars mission uses separate cargo and piloted flights. The nuclear thermal rocket is the selected method of propulsion to reduce the transit times and the exposure to zero gravity, space radiation and mass to low Earth orbit. The first mission to Mars is a cargo mission. This mission requires three launches for final assembly. Components of these three launches are then assembled into a Mars mission cargo vehicle using automated, on-orbit rendezvous and docking procedures developed in the lunar phase of the program. The activation of the nuclear engine propels the vehicle out of Earth orbit and on its way to Mars. After reaching the required velocity, the engine shuts off and the vehicle continues its journey. Mid-course propulsive corrections are also required. As the vehicle approaches Mars, the nuclear engine activates for insertion into Mars orbit. The cargo lander is sent to the surface in time to have the emplaced systems activated and checked out before launching the piloted mission.

The piloted vehicle consists of the crew in the Earth-entry vehicle, along with their Mars transfer vehicle, the nuclear engine, inflight experiments and consumables. The crew can be launched in the Space Shuttle, a Space Shuttle follow-on vehicle, or on a heavy lift launch vehicle. After on-orbit rendezvous and docking, the crew activates the nuclear thermal rocket to initiate trans-Mars injection.

The piloted vehicle carries contingency trans-Earth injection fuel to permit an abort from Mars orbit.

With Mars orbital capture and rendezvous with the cargo vehicle complete, the crew descends in their piloted lander to the surface of Mars. After completion of their surface stay, they ascend in their lander to orbit, using the same techniques used for the lunar missions to rendezvous and dock with the Mars transfer and Earth-entry vehicles in orbit around Mars. They then undock the vehicle and depart Mars orbit. The crew makes a direct entry into the Earth's atmosphere after injecting the nuclear stage into solar orbit.

Heavy Lift Launch Vehicle

250 metric tons capacity

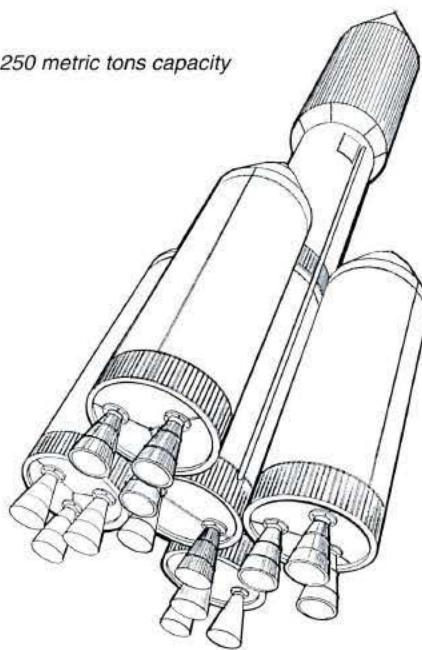

¹ NASA, Johnson Space Center, Code XE memorandum dated January 11, 1991, "Preliminary Heavy Lift Launch Vehicle (HLLV) Requirements for the Space Exploration Initiative," Norman H. Chaffee.

Mars Exploration

The major objective of this architecture is to explore Mars and provide scientific return. The emphasis of activities performed on the Moon is primarily as a preparation for the Mars mission. A significant lunar infrastructure is necessary, however, to test Mars equipment, systems and operations. This permits meaningful scientific return from the Moon.

Strategy

The emphasis of the architecture is on Mars exploration and science. The lunar infrastructure is developed only to the degree necessary to test and gain experience with Mars systems and operations and to simulate Mars stay times. The Moon is explored while developing operational concepts for Mars. For Mars, robotic pre-

cursor missions are used to scout the territory before committing to a landing site. Cargo and piloted landers are separate vehicles: the cargo landers travel one way to the surface, while the piloted vehicle is sized for crew transfer and minimal cargo from the planet surface. Habitats are built into the cargo landers, replicated and joined to build up living volume. This architecture is designed to be a minimal approach to achieving the program objectives.

Summary and Schedule

The projected schedule is shown below.

The first human mission to the Moon occurs in 2005 for a stay of 14 Earth days (one lunar daytime). A known site is chosen, based upon Apollo data, and precursors are not required. A subsequent lunar mission of 14 Earth days occurs the fol-

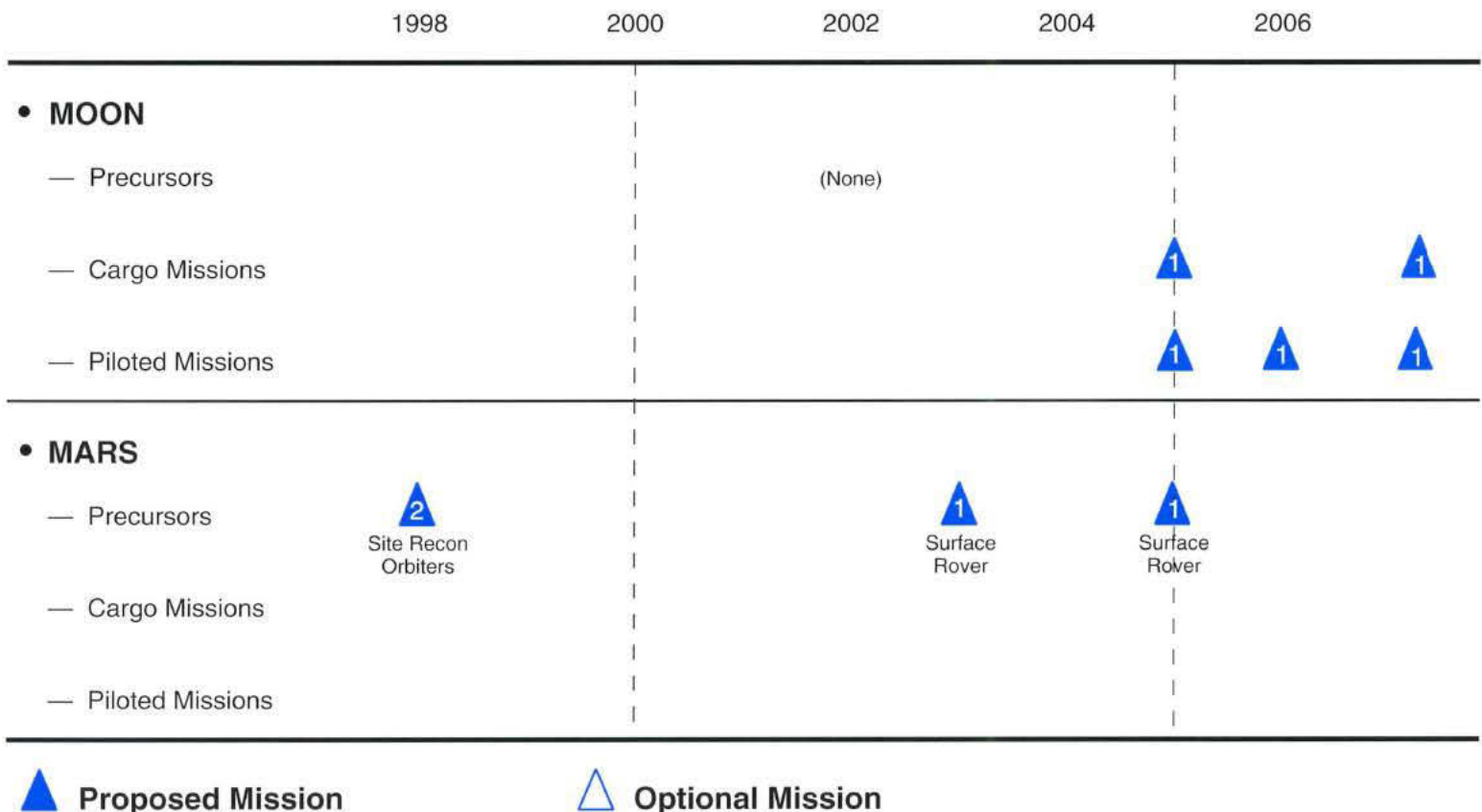

lowing year to the same site. In 2007, surface stays are extended on the Moon up to 60 days. In 2009, two lunar missions are flown as a dress rehearsal for the Mars mission, with a cargo mission preceding the piloted mission in 2008. The opportunity exists for additional lunar flights in 2010 and 2011 if further testing and validation are required.

A minimum set of precursors is flown to gather the data necessary for selecting Mars landing sites. These missions consist of two Mars site reconnaissance orbiters in 1998 and a rover in 2003 and 2005.

The Mars missions begin with a cargo mission in 2012. The first human mission to Mars occurs in 2014 with a surface stay of 30 to 100 days. The next flight occurs in 2016 to a different site for a 600 day stay. The next launch opportunities occur



Astronauts Collecting Martian Rock Samples

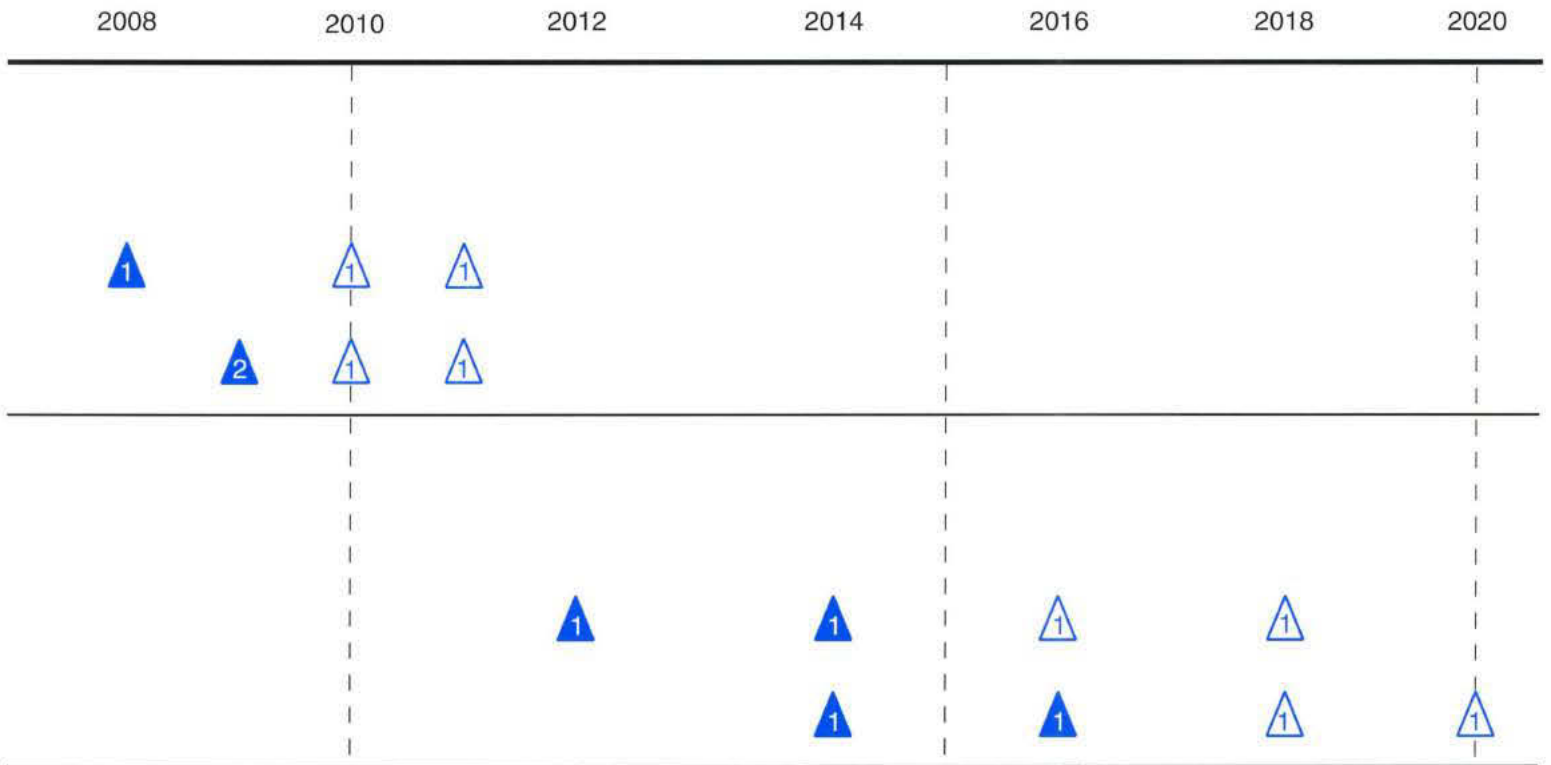

in 2018 with cargo missions preceding each piloted mission by approximately two years.

Lunar Phase

Lunar Precursors. The landing site is selected by reviewing the data and photography from Apollo and other sources, and requires no new lunar precursor missions. This process proved to be successful for six Apollo lunar landings.

Lunar Initial Operational Capability.

This Initial Operational Capability will demonstrate that we can return to the Moon safely, unload cargo and emplace and operate a habitat for at least a lunar daytime. The first human lunar mission is flown in 2005 with a crew of six. The piloted lander is preceded by a cargo lander that contains the habitat, a power supply, consumables, cryotank verification test equipment and an unloader. The initial stay is for 14 Earth days. Five crew members descend to the surface taking an unpressurized rover, with the sixth crew member remaining in orbit. They live out of the lander while setting up the habitat and its regolith shielding. Solar power is used for the initial stay. The first crew on the surface installs the solar flare warning system near the habitat.

Another five-member crew returns to the first landing site in 2006 for another 14 Earth days, living in the habitat, with a sixth crew member remaining in lunar orbit. They check out the condition of the equipment, check the cryotank verification test and deploy small instruments to survey and examine interesting geologic sites. If an Apollo site is chosen, the equipment left behind from that mission is examined to determine the effect of long term exposure on the lunar surface. Certain elements are disassembled and brought back to Earth for analysis. The successful completion of this flight constitutes achieving the Initial Operational Capability.

Lunar Next Operational Capability-1.

The next capability in this architecture is designed to demonstrate that we can operate effectively on the Moon for an extended period of time, including a lunar night (14 Earth days), using prototypical Mars equipment. This flight is the prelude to the dress rehearsal for the Mars mission. After achieving the Initial Operational Capability, a cargo flight is sent to the Moon the next year, 2007. This flight carries a pressurized rover and a nuclear surface power plant to the original landing site. This cargo mission is followed by a piloted mission with six crew members. The six crew members descend to the lunar surface. This mission would be 45 to 60 Earth days in duration. The crew fully evaluates the pressurized rover, including the telerobotics. Of necessity, they do meaningful science activities in the process of accomplishing their evaluations. They accomplish the reconnaissance leading to the selection of a nearby Mars rehearsal landing site on the Moon. They also accomplish a verification of all the procedures required by such operations. The nuclear power system is activated and its performance verified. Equipment is configured to permit continued remote operations and obtain further reliability data subsequent to the crew's departure. The successful completion of this flight constitutes achieving the Next Operational Capability-1.

Lunar Next Operational Capability-2.

At this stage, the aim is to perform a complete dress rehearsal for the mission to Mars while acquiring significant life science data. In 2008, the year following achievement of the Next Operational Capability-1, the Mars dress rehearsal is initiated with a cargo mission to the lunar site chosen for the Mars simulation, in close proximity to the original site. Moon analogs to Martian sites are shown on the next page. This flight carries the same cargo configuration that will be

MARS AND MOON SITE ANALOGS

Mars Western Hemisphere

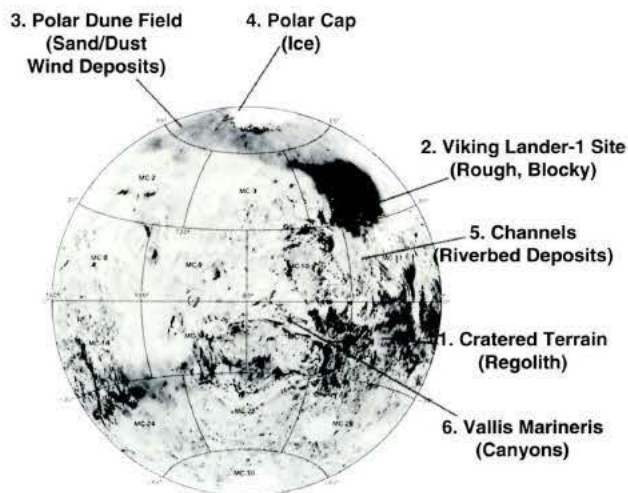

Moon Near Side

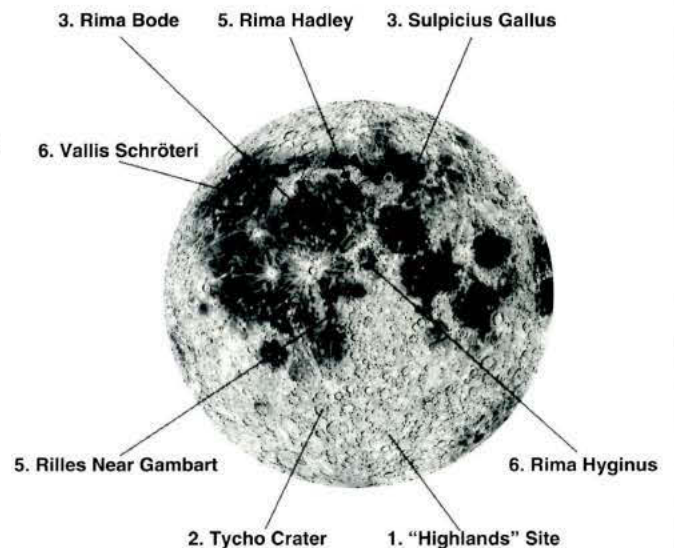

prepositioned at Mars prior to the first human mission. This includes a habitat, a pressurized rover, a nuclear power plant, an unloader/mover, scientific exploration equipment and communications equipment needed for Mars surface operations. All the systems and equipment are deployed and remotely operated just as on Mars. This remote operational validation continues for at least one year prior to sending a crew to the site.

A mission with a crew of six is flown in 2009. The crew stays in lunar orbit for a period of 120 days, a time comparable to a shortened Earth-to-Mars transit, then descends to the surface to stay for 30 days. They accomplish all the activities associated with the Mars mission during their stay, verifying procedures and operations critical to the success-

ful completion of the first Mars mission. The vehicles and systems flown are the same vehicles and systems to be taken to Mars, to the extent practical. For example, the lunar orbiting vehicle is the Mars transfer vehicle. The lunar lander could be the Mars lander. The use of this vehicle allows for realistic mission-critical evaluations of the performance of the systems and the crew with a high degree of operational fidelity. It also provides an opportunity to develop the procedures and techniques for the orbital crew to accomplish meaningful science using telerobotic systems on the lunar surface. Techniques and procedures developed in lunar orbit are directly applicable to their utilization in Mars orbit. These operations are done without the time delays

Figure 2

inherent in Earth operations of such systems on either the Moon or Mars.

While this flight of approximately 150 days' duration is in progress, a second mission is flown by another six-member crew that descends and lands at the original site with no delay in lunar orbit. The mission is planned to have them on the lunar surface when the orbiting rehearsal crew lands. Three of the crew members drive to the Mars rehearsal site in a rover and provide assistance to the Mars rehearsal crew after they land. The rehearsal crew is weighted with appropriate masses after landing, to verify their adaptation to the three-eighths gravity environment of Mars. The crew in place at the site will be able to assist in performing necessary life science experiments and protocols. They stay on the Moon after the rehearsal crew departs, verifying equipment operations up to a total mission duration of approximately 90 days. The successful completion of this phase of lunar operations constitutes the Mars mission dress rehearsal. When successfully completed, the Mars mission can proceed with minimum risk.

If redesigns are required that necessitate further testing on the Moon, there are opportunities to fly additional missions in 2010 and 2011 prior to launching the Mars cargo mission in 2012.

Mars Phase

Mars Precursors. The techniques for Mars exploration involve both people and robots. The overall approach is to achieve knowledge of Mars from robotic missions and then to follow up with detailed field science by humans. An important enhancing technique is the use of robotic telepresence to extend and augment human access during piloted missions to Mars. The precursor mission set described for this architecture is the baselined minimum for all Mars missions.

Landing sites on Mars are chosen for scientific interest. In order to assure adequate margins of crew safety, each site is certified prior to landing. Site certification involves collation of photographic and other remote sensing data to identify and map hazards. Current knowledge of Mars is considered inadequate to certify landing sites. Specifically, we do not possess adequate image data to see hazards, nor do we understand terrain types or surface conditions well enough to assure crew safety and their ability to do useful work at Mars. For these reasons, each architecture provides for site reconnaissance orbiters, which are two identical spacecraft for obtaining high-resolution (25 cm/pixel) contiguous imaging of potential landing sites. At least 12 candidate sites are imaged. The precursor spacecraft also carries additional instruments, such as a mapping spectrometer, to provide strategic science data to aid in site discrimination and selection.

In order to verify terrain models developed from the high resolution imagery and to certify site safety, two rovers are deployed before a piloted mission is launched. These rovers image the surface and subsurface, make in situ chemical and mineral measurements, and conduct tests for soil toxicity. Prime and backup sites are selected from the site reconnaissance orbiter data, and identical rovers are deployed at each site.

Communication orbiters are needed for data relay on rover and human missions. Combining this capability with that of the site reconnaissance orbiter is preferable, and this will be done if vehicle masses can be kept within launch vehicle constraints. Most of the precursor missions can be launched by existing expendable launch vehicles or the core of the heavy lift launch vehicle.

Mars Initial Operational Capability. The goal of the Mars Initial Operational Capability is to arrive at Mars

and successfully accomplish scientific exploration of its surface. The first mission with a crew of six establishes the Mars initial operational capability in 2014 with a surface stay of 30 to 100 days. The mission calls for pre-deploying as much of the needed equipment as possible on the Martian surface to allow for operations by the crew when they arrive. This cargo mission, therefore, must be launched during the previous window of opportunity in 2012. The cargo flight also serves as the validation flight for the nuclear thermal rocket system prior to the piloted flight in 2014. The emplaced equipment is remotely tested to ensure that all is ready and functional before the crew is launched. The mission concept is similar to that employed at the Moon; i.e., stabilized in Mars orbit, the crew descends, accomplishes their activities on the surface, ascends to Mars orbit, rendezvous and docks with the Mars transfer and Earth entry vehicles.

The habitat is the same design as the one tested on the lunar surface. Life support systems for both the Mars transfer vehicle and the Mars surface habitat are closed to the degree possible. This probably results in a system that is closed except for food. The power system is nuclear, with minimal photovoltaic emergency backup.

The cargo vehicle for the 2016 piloted mission arrives at Mars in 2014. If an emergency occurs during the 2014 piloted mission, the assets available in this cargo mission could be used. It contains Mars surface equipment and a habitat, Earth return propellant and a crew excursion vehicle.

Mars Next Operational Capability. The architecture next aims to achieve a long surface stay on Mars to perform extensive field exploration, including addressing difficult and complex scientific problems. The Next Operational Capability also

employs separate cargo and piloted vehicles. The cargo vehicle departs in 2014 and, pending the results of the 2014 piloted mission, lands at a different site to maximize science return. The piloted mission, again with a crew of six, launches in 2016. The option is available to return both the piloted and cargo missions to the original site and further develop the infrastructure. The stay time on the surface is on the order of 600 days to take advantage of the reduced mass to orbit with the conjunction class of mission. It is assumed that after the first Mars mission, confidence in system and human capabilities allows for longer mission durations. An in situ resource demonstration unit is included in this mission to test the feasibility of producing fuels at Mars. Such activities allow us to evaluate the potential for long term habitation and exploration of Mars by humans.

The option of repeating the long stay mission is available in 2018 and again in 2020 before the synodic window starts to narrow.

If the decision is made to accelerate our return to the Moon and go to Mars before the current goal of 2014, Architecture I lends itself to such acceleration. This would require early and robust funding.

On the Rim, North Ray Crater, Apollo 16



Science Emphasis for the Moon and Mars

This architecture's prime focus is balanced scientific return from both the Moon and Mars. Emphasized throughout are exploration and scientific activities, including complementary human and robotic missions required to ensure optimum return.

Strategy

The Moon and Mars are emphasized equally, and an early global assessment of both bodies permits a variety of initial missions designed to better understand global diversity. Life science data required for Martian missions are generated through extensive operations on the Moon.

The operational strategies of this architecture emphasize the use of human-controlled robotics (teleopera-

tions and telepresence) to assist human activity on the surface. Instrument emplacement focuses on early deployment of portable instruments which gather observation data independent of lunar location. In the latter stages of architecture implementation, emphasis shifts to larger scientific experiments and instruments after developing surface capabilities for construction, maintenance and operations. Continuous exploration activities yield a significant scientific return through the use of a balanced mix of human and robotic exploration techniques.

The option to pursue exploration of a near-Earth asteroid is included in this architecture. A precursor robotic probe could be sent to survey the selected asteroid, followed by a human mission.

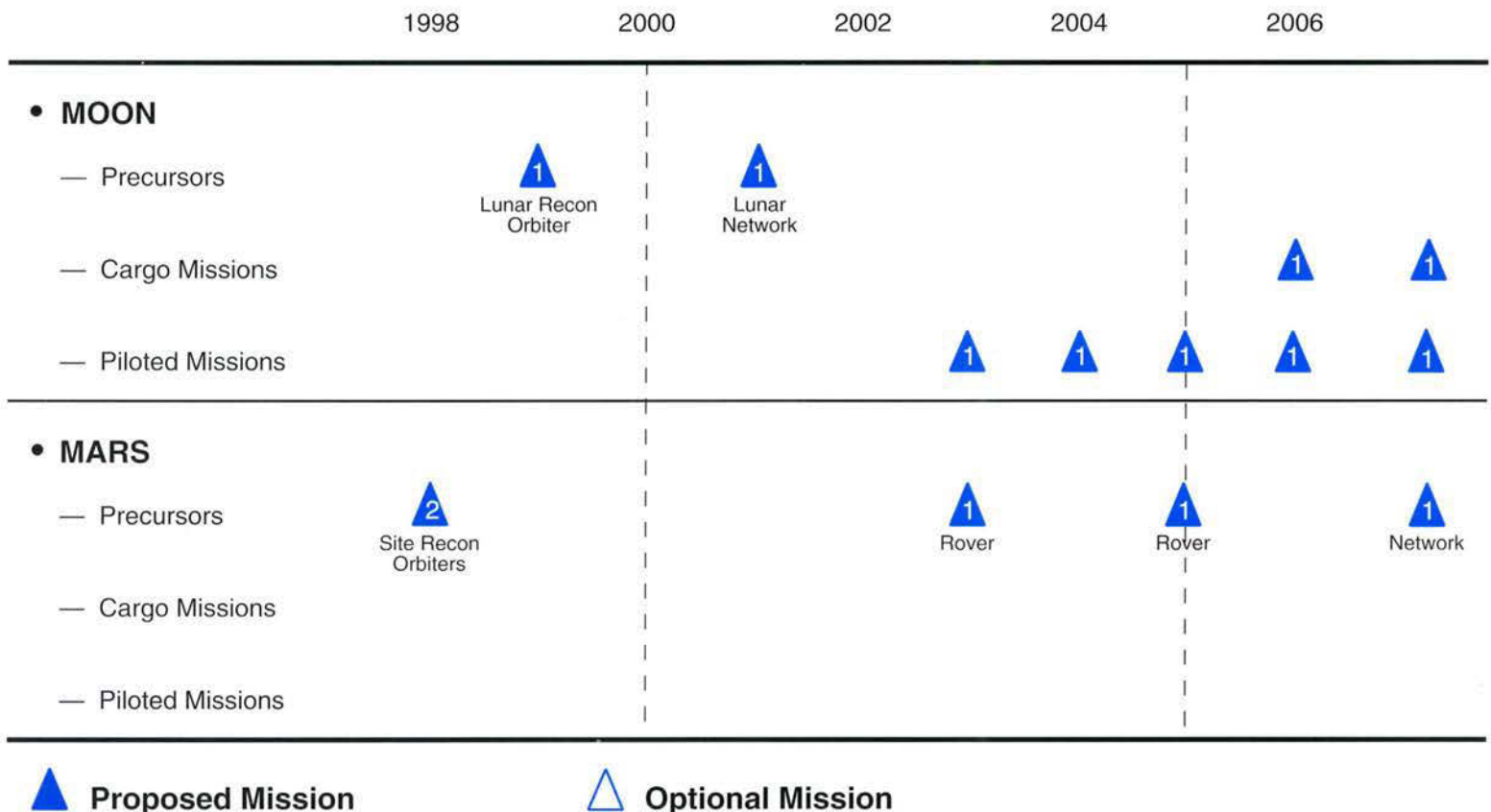

Summary and Schedule

The initial phases of this architecture occur on the surface of the Moon, with emphasis placed on exploration and scientific activities. These activities, along with the planned lunar precursors, provide a better understanding of the global characteristics of the Moon. Coupling this knowledge with the astronauts' growing adaptation to living and operating in the lunar environment, longer missions to the surface are planned, requiring a permanent crew habitat. In addition, more advanced systems enable extension of the crew work area beyond the habitat area for significant lengths of time. Gradually, an infrastructure is developed for the purpose of supporting the increasingly advanced exploration and observation activities. Construction and operational activities distant from



Martian Science and Exploration Facilities

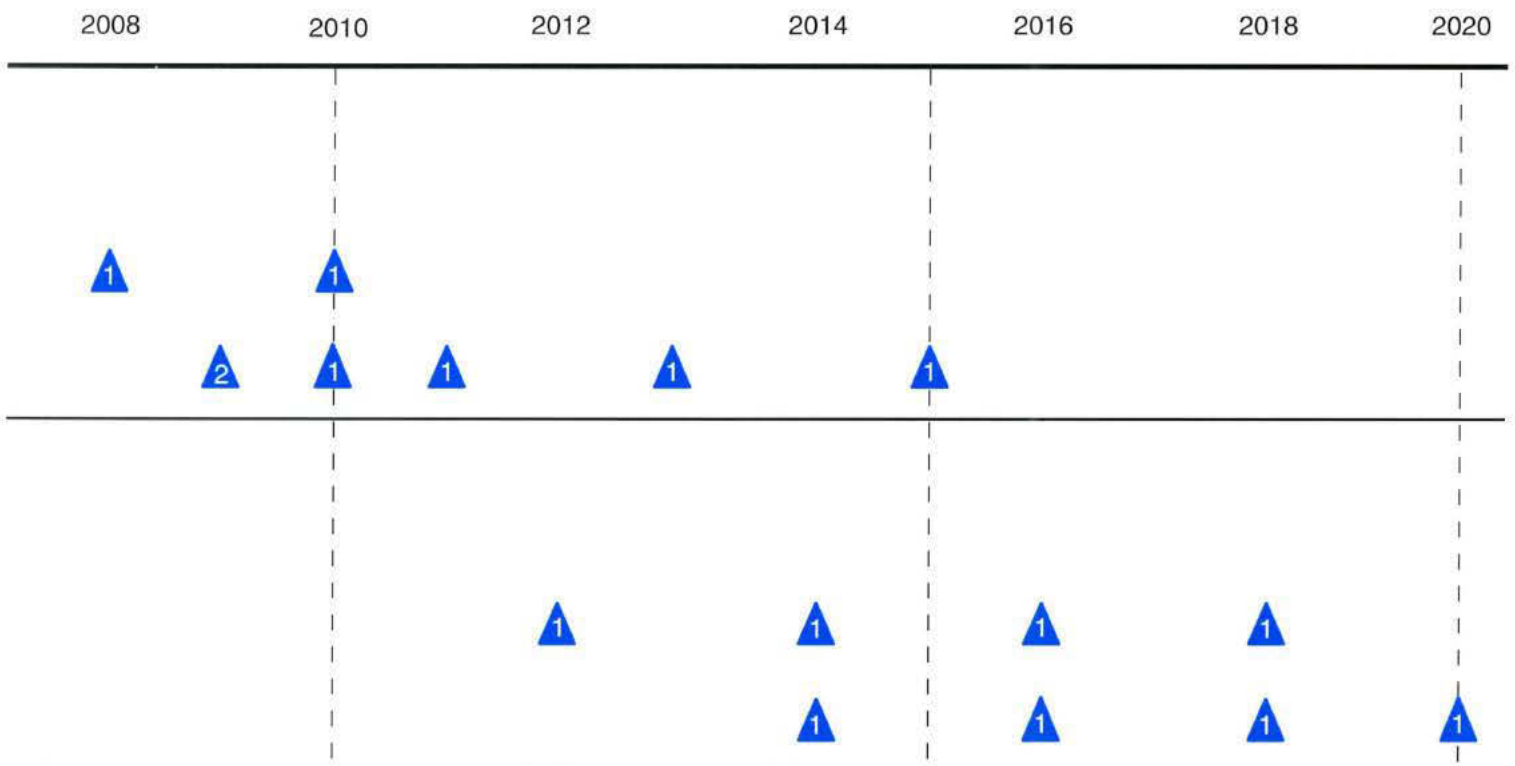

the habitat become commonplace. Complementing the progress of the surface activities are orbital activities in lunar orbit.

Subsequent to the establishment of the desired long term operational capabilities for exploration and science on the Moon, human missions to Mars take place. All knowledge gained by the activities in lunar orbit and on the surface becomes part of and is complementary to the dress rehearsal for the Mars mission.

Lunar Phase

Lunar Precursors. To conduct global reconnaissance and to assure that scientifically productive landing sites are selected, two robotic precursors — the lunar reconnaissance orbiter and the lunar network — are launched in 1999 and 2001, respectively. The lunar reconnaissance orbiter produces a global remote sensing data base, consisting of imaging, chemistry, mineralogy, topography and gravity data. The lunar network consists of a minimum of eight surface geophysical and environmental surface stations equally distributed around the Moon.

The network should have a minimum lifetime of ten years. Components of the geophysical station will be a seismometer, heat flow probe, a magnetometer, local geochemistry instruments (alpha particle counter and x-ray fluorescence spectrometer) and imaging instruments for terrain characterization. The environmental station will have instruments that measure meteorite flux and dust from secondary meteor impact crater ejecta, plasmas, fields and particles, and the lunar "atmospheric" composition (neutral and ion mass spectrometers).

Several locations for lunar landing sites are determined from the lunar reconnaissance orbiter and network data. Three sites which offer the most geological diversity and are complex and challenging enough that human presence is required, are selected for the Initial Operational Capability human landings.

Lunar Initial Operational Capability.

The lunar Initial Operational Capability of this architecture is designed to demonstrate a safe return to the Moon with significant exploration capability, to land at and explore three complex sites and deploy selected observation instruments. In 2003, the first human mission to the Moon lands at one of the three preselected sites. A crew of five lives in the lander during lunar daytime of 14 Earth days, with one crew member remaining in orbit. They have a pressurized rover with a traverse radius of 50 km (increasing to 100 km on subsequent missions) and a telerobotic prospector capable of being operated from the Moon surface, lunar orbit or from Earth. Observation instruments consist of an environmental conditions survey package, a portable magnetospheric observatory and an operations test telescope. A solar flare warning system is also included.

Surface activities focus on exploration of the Moon. Two astronauts utilize the rover to explore, conduct field work and deploy instrument packages. Other crew activities include emplacement of the observation instruments. In addition, crew members operate the local telerobotic prospector, a remotely controlled robotic device with various analysis instruments for both reconnaissance sampling and resource identification and characterization. In the following years, 2004 and 2005, two nearly identical missions occur at other selected sites, with the traverse radius increasing to 100 km from the lander.

Lunar Next Operational Capability-1.

The next capability is designed to both extend the length of human presence on the Moon and to establish a permanent crew-tended outpost, building up the lunar surface infrastructure. Additionally, more exploration and the construction of the permanent lunar observatory are begun. The most notable difference from Initial Operational Capability to

the first Next Operational Capability in 2006 is the change in stay time to 90 Earth days and the delivery of supporting equipment on a cargo flight. Accompanying the six-member crew is their habitat with a nuclear power supply capable of generating the necessary power throughout the lunar day and night cycles. The permanent site is selected from one of the previously visited sites. The pressurized rover left by the previous crew is utilized; traverses up to 100 km radius from the landing site are conducted. Construction of the observational instruments begins, including a transit telescope, a low energy cosmic ray detector, and a very low frequency array. An in situ resource utilization system experiment and a robotic prospector complete the remaining payload.

This capability concentrates on the construction and operation of the observation instruments, along with extended duration rover traverses. Exploration surface activities grow to five Earth-day missions away from the habitat in the pressurized rover. A four-element, very low frequency array is set up approximately 30 km from the habitat. The transit telescope is emplaced 10 km from the habitat. Astronauts begin the in situ resource utilization experiment and continue resource identification and quantification, with reconnaissance sampling occurring via the two available local prospectors. Additional activities include life sciences experiments and installation of the habitat waste management system.

Lunar Next Operational Capability-2. The goals at this capability are to perform long duration stays on the Moon for life sciences, conduct significant surface exploration, increase the capability of the observatory, and experiment with life support loop closure. The additional support equipment is provided by a cargo flight. The operational capability in 2007 doubles the surface stay time to 180 days at the

same site. The six-member crew lives in the existing habitat. Along with the existing rover, the crew has available to them an improved pressurized rover, which has increased range and appropriate radiation shielding to accommodate longer exploration excursions. In addition, the observation instrument payload for this mission consists of a 4 m telescope, a submillimeter interferometer, and a very long baseline radio telescope. A life support system with a high degree of closure is included, as are consumables required for the entire mission.

Surface activities include extended exploration excursions lasting 14 Earth days in the improved rover. Placement of a small robot at the edge of the rover range further extends the area accessible to humans. The 4 m telescope is emplaced 10 km from the habitat. The submillimeter interferometer placement is 1 to 10 km from the habitat.

Surface life science activities are enhanced, as well as life support capabilities, with the installation and testing of a waste management system for the habitat. Attempts are made at food production and breathing gas self-sufficiency through the use of experimental in situ resource utilization.

Lunar Next Operational Capability-3. The mission associated with this Next Operational Capability supports the dress rehearsal activities for the mission to Mars (as described in Architecture I) during 2008 and 2009. The crew for the dress rehearsal stays in lunar orbit for 200 days, providing additional life sciences data when compared with Architecture I. Orbital activities include operating the Mars transfer vehicle in lunar orbit, as previously described in Architecture I. The crew then descends to the lunar surface with a stay time of 30 days prior to returning to Earth.

Another crew, as in Architecture I, is launched to the lunar surface to

Radio Telescope Emplaced in Lunar Crater



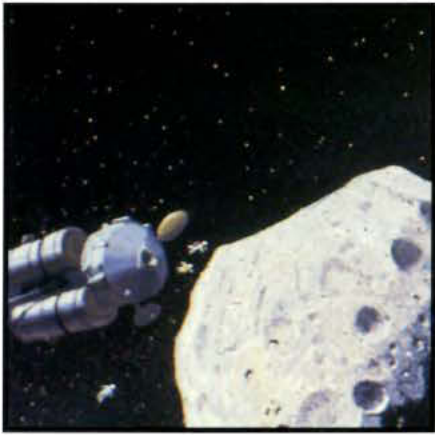

Reconnaissance of Near-Earth Asteroid

provide assistance to other crews arriving from orbit.

Lunar Next Operational Capability-4.

Expanding the operating capabilities of the lunar outpost is emphasized in this phase, with increased surface exploration and refinement of the lunar observatory facility. The missions for the fourth lunar operational capability will occur in the years 2010, 2011, 2013 and 2015. The missions continue to develop lunar surface capabilities and provide science and exploration opportunities. These missions could be flown to new or existing sites.

Mars Phase

This architecture uses the same Mars mission scenario and science exploration activities previously described in the Mars exploration architecture. This constitutes the establishment of the Mars Initial Operational Capability. However, this architecture requires several additional Mars missions designed to fulfill planetary geoscience exploration plans. Only those additional Mars missions and activities are described.

Mars Precursors. Additional Mars precursors for this architecture deploy a surface network for geophysical and environmental measurements. This network carries the same type instruments as described in the Moon precursor section, but in addition, deploys meteorological stations to measure Martian weather conditions. Eight surface stations are deployed equidistant around Mars. The network is emplaced in 2007 and should have a minimum lifetime of ten years.

Mars Next Operational Capability-1.

At Next Operational Capability, the emphasis is on taking advantage of the 600 day stay on the Martian surface to conduct extensive field study of complex areas. Next Operational Capability-1 consists of two identical missions in 2016 and 2018 to new

locations. The surface activities for these missions are already identified in Architecture I and emphasize the expanding capability to conduct human field work on Mars with long stay Martian missions.

Mars Next Operational Capability-2.

The Next Operational Capability is the establishment of permanent base. A significant improvement in capability is accomplished by the use of in situ resources (hydrogen, water, methane and oxygen) for life support, rovers and propellant for the ascent vehicle. Next Operational Capability-2 occurs in 2020, once a permanent site is chosen. The next mission is also a 1,000 day class mission with surface stay times up to 600 days. The crew size increases to 12. Habitats are joined to increase living volume. Exploration and science continue to be emphasized. Travel is possible to other previous landing sites, and the existing infrastructure is used for extended stays. This allows for exploration from more than one site.

Near-Earth Asteroid Option.

This option envisions both robotic and human missions to a near-Earth asteroid. Asteroids are fragments of planetary materials; their study is relevant to the origin of the Solar System and the early history of planetary bodies. The near-Earth asteroids have orbits that cross or approach the Earth's orbit about the Sun; they may be visited at energy costs comparable to lunar or Martian missions (total delta-V of 9 to 12 km/s, from low Earth orbit).

Two broad classes of asteroids exist in Earth-crossing orbits: primitive and differentiated. Primitive asteroids are apparently the source of chondritic meteorites, objects that are pieces of the original solar nebula and, as such, contain important chemical and isotopic clues to the origin of our Solar System. Additionally, they tend to be rich in volatile elements, such as hydrogen in the form of

water, and may serve as a major space resource. Differentiated asteroids are the disrupted fragments of small planetoids; they contain a record of the early geological evolution (e.g., melting and igneous differentiation) of planetary bodies.

A robotic precursor could rendezvous with a selected near-Earth asteroid and map its chemical and mineralogical composition. Several possibilities exist for candidate missions since there are several asteroid mission opportunities each year. It is not required that the robotic mission visit the same asteroid as the human mission, but such a profile does enhance the scientific return by providing precursor reconnaissance to direct the human exploration.

Human missions to asteroids could vary from 300 days or longer, with stay times of 10 to 100 days in the vicinity of the asteroid. The asteroids are typically less than 2 km across and gravity is negligible. Extravehicular activities might be achieved using Manned Maneuvering Unit type backpacks. Science activities at the asteroid consist of mapping, sampling and emplacing instruments. It is important to determine and understand variations within the asteroid and to collect representative samples. In situ resource utilization experiments are deployed to determine the resource potential of the body. Mapping of the complete asteroid is also possible using active seismic and electromagnetic techniques.

Mars Robotic Explorer

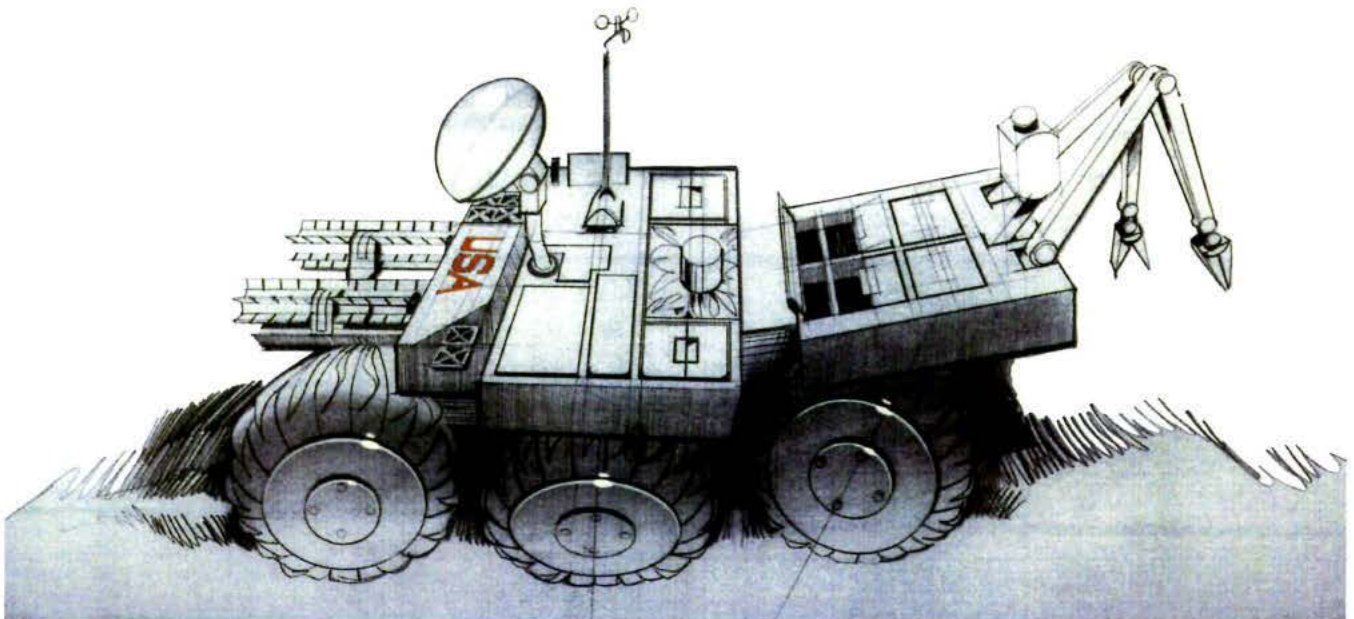

Moon to Stay and Mars Exploration

This architecture emphasizes permanent human presence on the Moon, combined with the exploration of Mars. Long term human habitation and exploration in space and on planetary surfaces are conducted, providing terrestrial spinoffs to improve our life on Earth and to increase our knowledge of both the Solar System and ourselves.

Strategy

Orbital and surface precursors are used to select a site prior to the establishment of permanent facilities. The lunar transportation infrastructure is established through frequent missions to the Moon. One of the major objectives is to build towards life-support self-sufficiency for breathing

gases and food production on the Moon. Waste management technologies are developed to support an extended human presence on the lunar surface. Sufficient and comfortable living space should be provided for routine activities rather than austere and spartan features inherent in the other architectures. Limited independence from Earth, while maintaining an effective communication and video link for science and education, is a goal of the architecture.

The permanent presence of humans on the Moon gives us an impressive scientific capability. Science on the Moon emphasizes exploration and observation. For lunar exploration, extended traverses in a pressurized rover permit detailed study of complex and puzzling lunar features and processes. Robotic assistants extend human reach for great

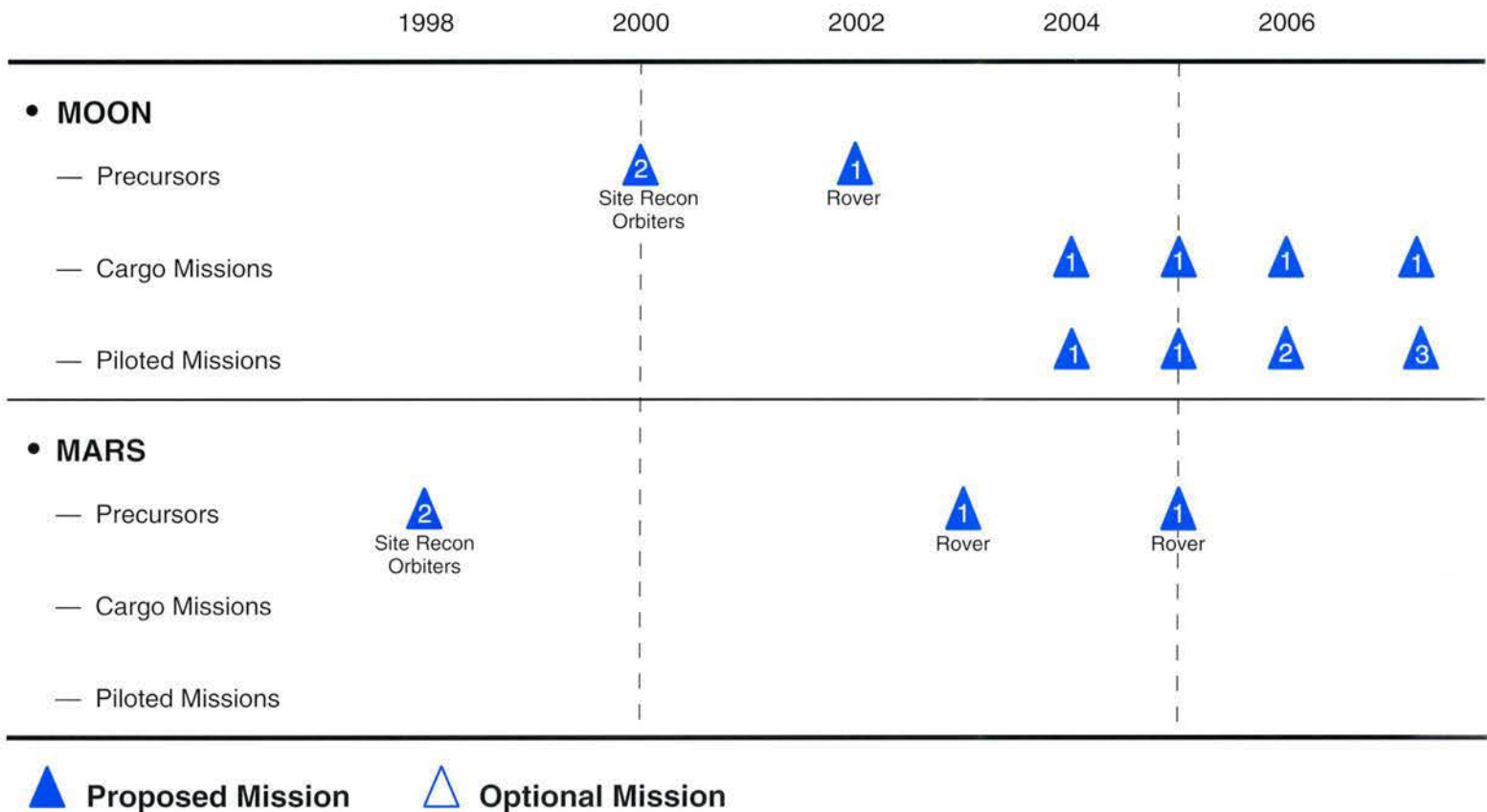

distances across the lunar surface. With permanent presence on the Moon, advanced and sophisticated astronomical observatories are installed and maintained. Complicated instruments, such as optical interferometers, are emplaced by the human inhabitants of the Moon, giving us unprecedented views of our universe.

Extensive space and lunar surface operations are conducted on the Moon to provide the necessary life science and engineering data to prepare for future exploration missions to Mars. After a habitat is established on the Moon and preparation for a Mars mission conducted, the human exploration of Mars begins.

Summary and Schedule

The architecture uses lunar orbital and surface rover missions to obtain



Lunar Base

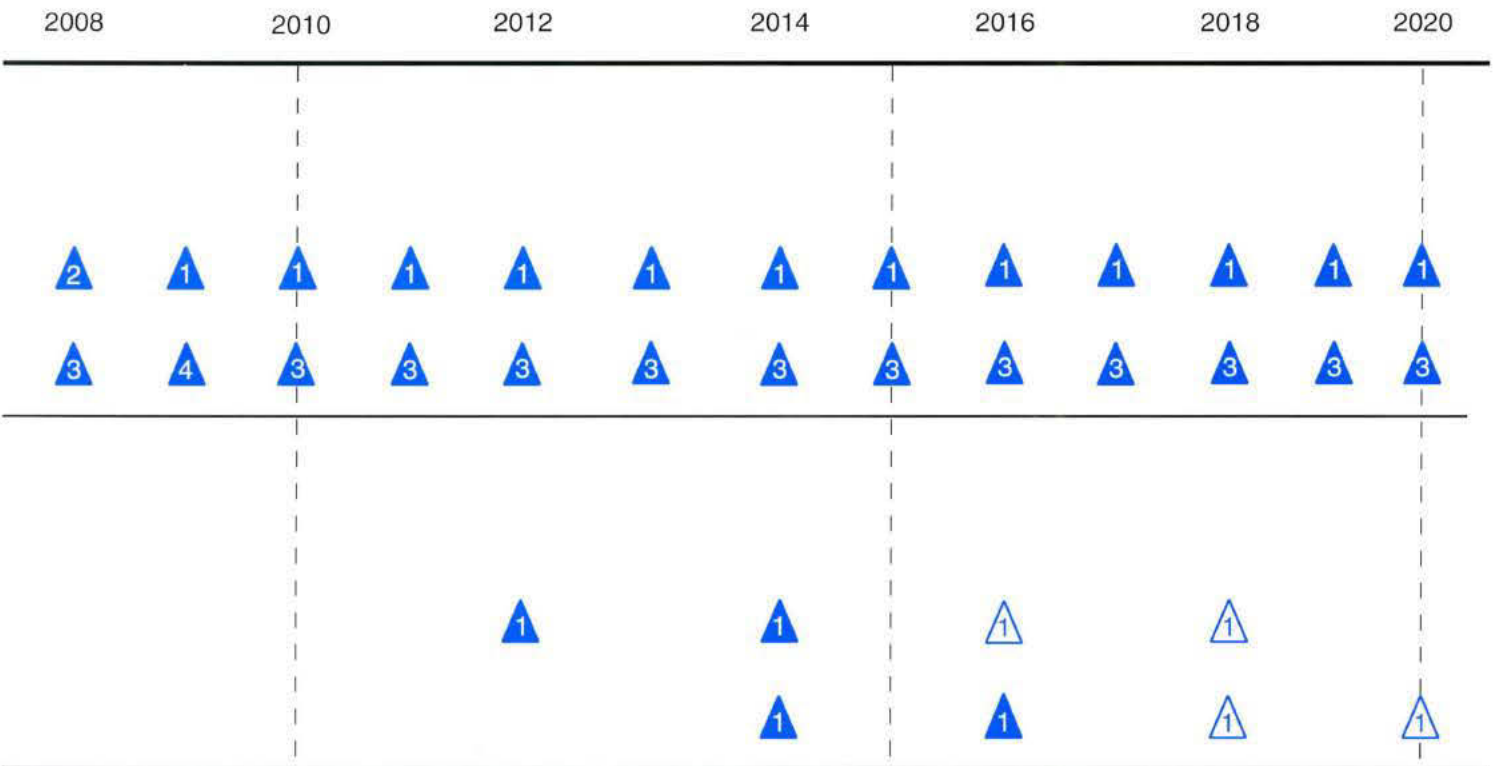

global and local information designed to optimize the location of the permanent outpost site on the Moon. At the Initial Operational Capability, cargo and piloted flights are launched, sending a crew of five to the surface to emplace the habitat and begin living and working on the Moon in 2004. Subsequent capabilities and Next Operational Capabilities 1 in 2005 and 2 in 2006 increase the capacity of the outpost for human habitation, building up to a capacity of 18 by the Next Operational Capability-3 in 2007. Simultaneously, the crew members will explore the lunar surface, conduct extended traverses and emplace scientific instruments and resource and life sciences experiments. The buildup of substantial lunar surface infrastructure will permit construction of a large astronomical observatory and extensive surface exploration. In 2009, the Mars rehearsal mission is flown, partly using the capabilities of the permanent outpost to demonstrate equipment and procedures for the Martian mission. The Mars phase of this architecture consists of the exploration scenario described in Architecture I.

Lunar Phase

Lunar Precursors. Reconnaissance orbiters are launched in 2000 to gather information on potential landing sites and to collect global remote sensing data. A robotic rover is sent to the lunar surface in 2002 to further investigate and characterize the selected sites in preparation for a piloted landing on the surface of the Moon in 2004. This precursor rover may carry instruments to image the subsurface (e.g., ground-penetrating radar) to certify the site for the installation of a permanent habitat.

Lunar Initial Operational Capability. The goal of this Initial Operational Capability is to return safely to the Moon and establish a crew-tended site while conducting survey work for

a future permanent habitat. The launch of the cargo mission takes place in 2004, followed by a piloted flight with a six-member crew. The cargo flight carries a habitat with an airlock, an unloader, a nuclear power supply, a bulldozer, the cryotank verification test equipment, portable science instruments, an optical test telescope, pressurized rover and a solar flare warning system. The piloted mission delivers five of the crew to a site near the cargo ship, while the sixth crew member remains in orbit. The piloted mission carries an unpressurized rover and supplies for a 14 Earth-day mission (one lunar daytime).

The crew sets up the habitat and nuclear surface power system. This activity includes preparing the site, unloading and shielding the habitat with regolith, and checking systems to ensure proper operation. The crew emplaces, tests and activates the nuclear power supply, which will be located approximately 1 km from the habitat, and activates the solar flare warning system. The habitat and transportation systems are optimized for the Moon. However, the experience gained in both equipment and operations from the lunar background are directly applicable to Mars missions.

The crew lives in the lander until the habitat is operational. They also perform detailed surveys of the site for the permanent habitat and various equipment sites; some surface scientific exploration is also undertaken in addition to performing habitat installation. The crew emplaces portable instruments and an optical test telescope within 1 km of the habitat site and secures the site for the future arrival of the next crew.

Lunar Next Operational Capability-1. At this stage, the objective is to remain on the lunar surface safely through a complete lunar day/night cycle while establishing the infrastructure for the permanent habitat.

The Next Operational Capability of this architecture takes place in 2005. A cargo mission brings a pressurized rover and other cargo, including consumables. The six-member crew flies to the Moon. Five crew members land and stay on the lunar surface for 40 Earth days. The sixth crew member remains in lunar orbit. The crew sets out additional portable instruments and an in situ gas demonstration unit within 10 km of the habitat. Using the bulldozer, the crew prepares sites for emplacement of the transit telescope and the 4 m telescope. Additionally, the crew prepares rough layouts of roads, landing sites and areas for future expansion of the habitat. The crew has the opportunity to perform at least two long traverses in the pressurized rover to sites of geological interest; the radius of rover operations is up to 100 km for this second trip to the Moon.

Lunar Next Operational Capability-2. At the next stage of capability, the ability to emplace and operate multiple habitats while accumulating life science data and operational experience is demonstrated. Initial demonstrations of resource utilization, food production and waste recycling are completed. This Next Operational Capability takes place in 2006 with two piloted missions preceded by one cargo mission. The cargo consists of a habitat (to be attached to the existing module on the lunar surface) and a volatile production plant.

Two six-member crews are launched within a week of each other, both staying for 90 days on the surface. The first piloted mission carries a small unpressurized rover in order for the crew to reach the cargo ship on landing, a resources laboratory, waste recycling demonstration, and an optical interferometer.

The crew begins food production and waste management demonstrations, in addition to conducting five-day scientific exploration sorties in the pressurized rovers. They install

and align the optical interferometer and emplace the gas production plant. The crew also investigates the possibility of using indigenous materials for future construction on the Moon.

Lunar Next Operational Capability-3. The permanent presence of humans on the Moon is the goal of this phase, featuring regular resupply and crew rotation. Additionally, food production, life support loop closure, and in situ gas production activities are emphasized. The third Next Operational Capability is scheduled for 2007 and consists of cargo and piloted missions. The cargo ship carries a third habitat, increasing the total inhabitant capacity of the outpost to 18. A second bulldozer to be used for continued development of the out-

Astronaut Collecting Lunar Sample, Apollo XII

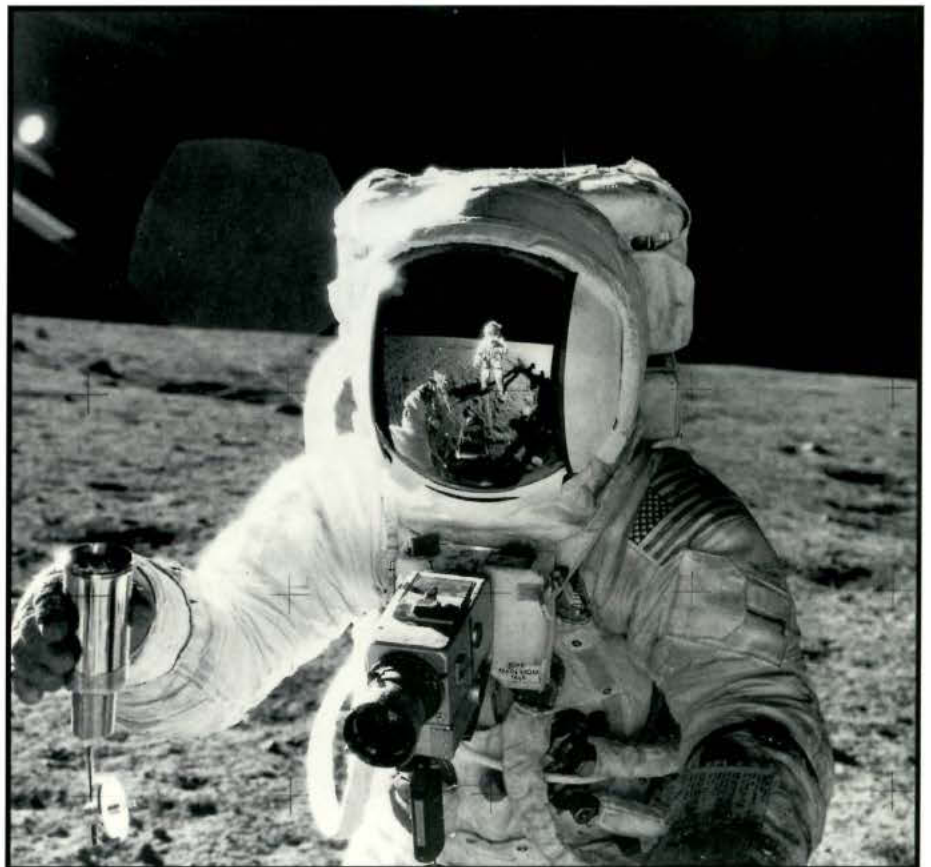

post infrastructure is brought on the next cargo ship.

In 2007, six-member piloted missions will be launched in the first, second and third quarters, building to an outpost capability of 18 crew members living and working on the Moon. Each crew of six will rotate yearly. In 2008, crews of six will again be launched in the first, second and third quarters to replace the crews sent the previous year. A cargo ship with additional supplies will be sent in the fourth quarter. This quarterly launch rate will be continued, maintaining the outpost population at 18 crew members. An option would be to decrease or increase the outpost population by varying the launch rate in any given year. However, in order to increase the population greater than 18, an additional habitat must be added to the outpost. Additional missions could continue past 2020.

In this stage, the goal is to approach self-sufficiency in food production and achieve demonstration levels of production of breathing gases and water. Fourteen-day exploration traverses are conducted with the pressurized rovers; radius of operations is maintained at 100 km. These long duration trips will permit detailed geological investigations to be conducted, including significant field work. At the lunar observatory, the aperture of the 4 m telescope is increased to 16 m by the addition of modular sections.

An important aspect of this long mission is to prepare for missions to Mars while living on the Moon. This long duration on the Moon creates an important database on human presence in a reduced gravity environ-

ment. In addition to monitoring the human effects of such presence, the crew conducts those operational activities representative of the Mars mission.

Lunar Next Operational Capability-4.

This capability begins in 2009 and prepares for Mars missions by conducting the Mars dress rehearsal missions outlined in Architecture I. This dress rehearsal requires only one additional mission over the three planned, as support would be provided by the lunar inhabitants in addition to their other duties. Crew members already on the surface travel to the simulation site and are available to provide assistance as in the other architectures. An additional crew will not be required to be launched for the 90 day mission outlined in Architecture I.

Mars Phase

This architecture uses the common Mars exploration described previously in Architecture I. The extensive knowledge base on human habitation derived from the lunar experience greatly aids the transition to long-duration stays on the Martian surface. Such experience includes optimum methods of habitat emplacement, surface operations, dust and environmental control and use of indigenous resources. Some commonality of resource utilization techniques and equipment is expected to ease logistical problems for the 600 day stay on Mars. Just as importantly, human physiological and psychological effects of long stays on planetary surfaces will be much better understood as a result of the lunar outpost experience.



This image of the Moon was taken by the Galileo spacecraft at 9:35 a.m. PST Dec. 9, 1990, at a range of about 350,000 miles.



Lunar Resource Mining

Space Resource Utilization

As in the days of the great terrestrial exploration missions, this architecture makes maximum use of available resources to support the space exploration missions directly. It also seeks to develop a large class of available resources for a broader range of transportation, habitation, life sciences, energy production, construction and many other long term activities. The goal is first to reduce the direct expense of going to the Moon and Mars, then to build toward self-sufficiency of long duration space bases and eventually to return energy and resources to Earth.

Strategy

Space is a unique store of resources: solar energy in unlimited amounts, materials in vast quantities from the surfaces of the Moon and Mars, gases from the Martian atmosphere, and the vacuum and zero gravity of space itself. With suitable processing, these raw resources are transformed into useful products. These products,

while increasing exploration efforts, provide bulky materials at a fraction of the cost of transporting huge masses from the deep gravity well of Earth, supply much of the energy needs of pioneering space activities, produce the constituent gases for air and would generate fuel for use by both chemical and nuclear rockets. Eventually, some space resources, especially solar energy and Helium-3 (a potential fuel for future fusion power plants), could be exported back to Earth. This could maximize the return on the investment of going to space, and allow cost effective expansion of space activities.

The implementation of this architecture entails several steps. First, resource extraction processes must be verified on Earth prior to space demonstration. In the case of the Moon, it is possible to use synthetic regolith on the Earth and to simulate other conditions which exist on the Moon to run a prototype plant. In the case of Mars, simulating the carbon dioxide atmosphere at the correct temperature and pressure is equally feasible. In both cases, it is possible to gain a high degree of confidence prior to ever leaving Earth. Next, the location and quantities of resources on the Moon, Mars and other bodies must be assessed. Some of this characterization is done remotely from Earth, but the general plan is to conduct robotic missions to map the Moon and Mars, emphasizing resource location and quantification.

An early lunar experimental plant is established to demonstrate the feasibility of extracting hydrogen and oxygen, other related volatiles, and industrial feedstocks from the lunar regolith. This experiment also demonstrates an ability to operate such a process from Earth remotely and verifies that the gases produced can be separated and stored for lengthy periods on the Moon.

The focus on Mars is similar; prototype facilities demonstrate extraction and production of hydrogen,

methane and oxygen from the Martian atmosphere autonomously, including storage for later use. From there, the strategy is to develop lunar manufacturing capabilities further to enable production of specific products which are made from the processed regolith. These include items such as solar cells, structural materials, formed metals, various fuels and other pure gases. These strategies are pursued with the goal of achieving lunar self-sufficiency, then build toward eventual production of export quantities of Helium-3 and electrical power. On Mars the goal is to eventually achieve self-sufficiency.

Finally, an infrastructure is needed to store, transport and use lunar-produced fuel to power rocket vehicles landing on the Moon, moving in Earth orbit and moving between the Earth and the Moon. This phase highlights the powerful effect of using space resources to greatly reduce cost and dependency on Earth. Fewer heavy lift launches are then required to support lunar and Martian activities.

Summary and Schedule

The Moon is emphasized because it is nearby and has known valuable resources which are extractable with relative ease from the regolith. Mars is secondary because its distance from Earth is much greater.

Lunar activity begins with a pair of site reconnaissance orbiters in 1999. A telerobotically operated rover verifies site suitability two years later. In preparation for the first human return mission, an experimental resource processing plant is landed at the selected site in 2003. In 2004, a crew of six arrives for a 14 Earth-day (one lunar daytime) stay. They live out of the lander and bring a small, unpresurized rover for local exploration. The next three piloted missions, in 2006, 2008 and 2010, are all to the same site and continue the expansion of resource processing capability, base infrastructure, habitats, exploration and science. The crew size remains constant at six, but the stay duration grows progressively from 45 to 180 days. In 2010, a small base exists which is capable of supporting up to

Lunar Boulder Near Taurus Littrow, Apollo XVII

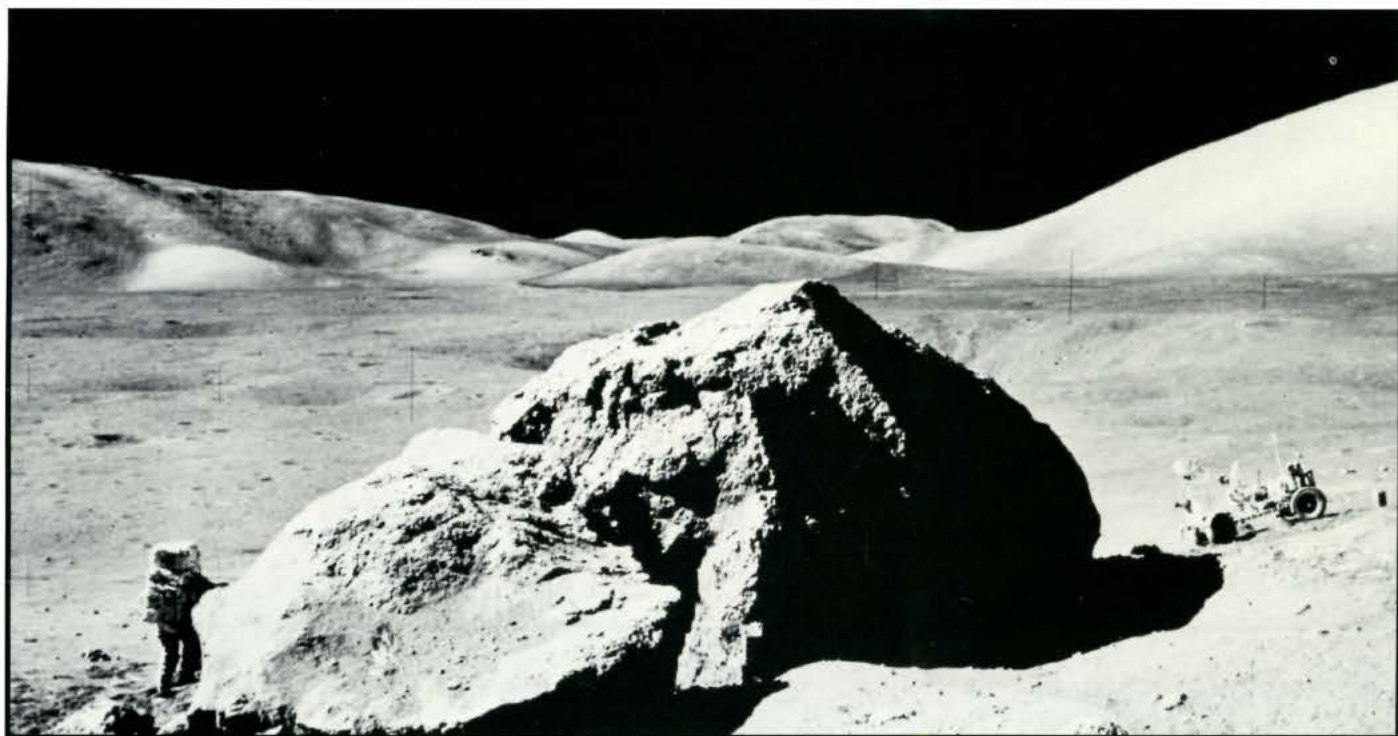

12 people at a time. After a Mars dress rehearsal mission is performed on the Moon in 2011, the Mars mission is conducted. Special resource utilization experiments on Mars are featured in keeping with the theme of this architecture. In each phase, buildup of capability is highly dependent upon the success of the preceding activity.

Lunar Phase

Lunar Precursors. Lunar activity begins with a pair of reconnaissance orbiters in 1999. Data from these satellites allow selection of a site which has excellent resource potential, but which also has superior characteristics for exploration, science and habitation. A telerobotically operated rover verifies the suitability of the site two years later. Then, in preparation for the first human mission, an experi-

mental resource processing plant is deployed at the selected site in 2003. Operating autonomously, this small plant produces and stores oxygen as its main product, lesser amounts of hydrogen and solar wind-emplanted gases, and demonstration amounts of other materials.

Lunar Initial Operational Capability.

The goal of the Initial Operational Capability in this architecture is to return safely to a site on the Moon with excellent resource potential for a stay of a lunar daytime while demonstrating in situ fuel production for use in a surface rover and in ascent/descent vehicles. Human activity on the Moon begins in 2004 with the arrival of a crew of six, with five crew members going to the lunar surface for a 14 Earth-day stay. They live out of the habitat and bring a small,

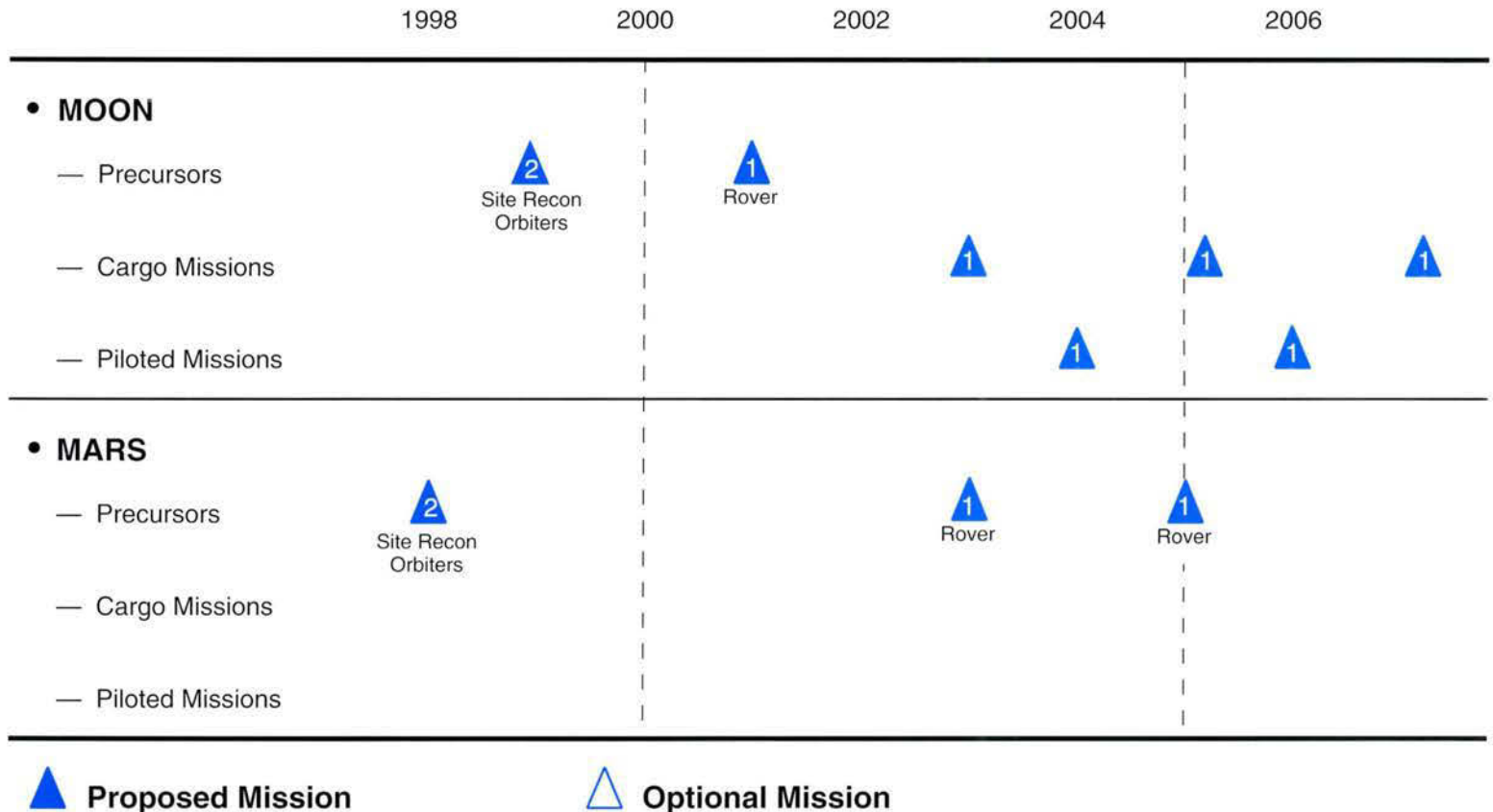

of varying lengths over the long term. Each mission provides a measurable increase in capability and a logical decision point for determining the final configuration of the Next Operational Capability.

Throughout this period, the focus of the increasing activity on the Moon continues to be resource development. The intent is to produce, store and use a wide variety of lunar materials including gases, for fuel and air, fused silica sheets and beams for construction, solar cells (made from lunar material) for power, and experimental quantities of Helium-3 to be exported for use in the Earth-based fusion program. Other experiments take place at the Moon site such as beaming power back to Earth or to an orbital cargo transfer vehicle to test the usefulness of that technology, trial export of limited quantities of construction materials and solar cells to evaluate their usefulness, and testing of processed regolith as soil for growing food in reduced gravity.

The earliest potential payback is to use lunar-derived fuel — in the form of hydrogen or methane, plus oxygen — first to power lunar vehicles such as rovers and utility equipment; then to refuel lunar ascent/descent stages to or from lunar orbit or a Lagrange point with cargo; and finally to fuel transfer vehicles between the Earth and Moon. The Lagrange point staging area may prove attractive. The initial propulsion is conventional chemical, employing liquid oxygen and liquid hydrogen or methane, but because liquid hydrogen is an excellent working fluid for a nuclear thermal rocket or a plasma thruster, it could be eventually used in these applications as well. Methane may be manufactured on the Moon and Mars, and is storable, which may prove attractive for local transportation.

The feasibility of beamed power is tested using power generated on the

Moon and beamed to a vehicle in space. A further test beams power to Earth to demonstrate the potential of importing energy from space. This test establishes the operational limits of beamed power and determines if transmission to Earth can be accomplished economically.

The basic features of this concept call for continuously expanding production and storage capabilities for fuel gases on the Moon. Development of transfer and landing vehicles which are reusable and refuelable on the lunar surface, in Earth and lunar orbit, or at a Lagrange point, would follow. These vehicles transport fuel from the Moon to both lunar and Earth orbit. There are both cargo and personnel transport vehicles, and the cargo transport type is configured as a conventional cargo carrier or tanker. The result is a lunar-based transportation infrastructure.

The above applications are far from being an exhaustive list of the uses of lunar resources. The concept is to encourage the development and use of resource categories not specifically stated or envisioned at this time. More opportunities may arise, innovation is encouraged and eventual transition to commercial activities is stimulated. Three things are certain: using resources near at hand potentially lowers the long term investment in space activities, broadens the range of human activities in space, and provides a large payback in later years.

Lunar Next Operational Capability-2.

This Next Operational Capability will perform the dress rehearsal for a mission to Mars. The fifth piloted mission to the Moon in 2011 returns to the established site, but is planned as the dress rehearsal of the Mars mission. The total mission duration is 500 days, with only 40 days to be spent on the lunar surface; the rest is spent in lunar orbit, 200 days before landing and 260 days after leaving

the Moon and before returning to Earth. This simulation mission uses the full suite of equipment to be used for the actual Mars mission as much as practical, including the equipment supplied by a separate cargo flight in 2010 as in Architecture I. When the crew of six lands on the lunar surface, their activities parallel those planned for Mars. An additional six crew members launched earlier are available on the surface assist the next crew upon landing. Because this simulation mission takes place close to the existing lunar base, there are extensive additional equipment, living quarters, and resources available in an emergency. Finally, the Mars prototype equipment left behind at the end of the mission augments the infrastructure of the lunar base.

Human habitation on the Moon after the simulated Mars mission continues on either a periodic basis or evolves to permanent presence. If the promise of resource development and use is realized, extensive human presence is feasible.

Mars Phase

Mars Precursors. The precursors for this architecture are the same as those denoted for Mars in Architecture I: two site reconnaissance orbiters and two surface rovers to certify and characterize the landing sites on Mars.

Mars Initial Operational Capability.

The Initial Operational Capability in this phase is similar to the one described in Architecture I with the addition of some resource utilization experiments on the Martian surface. Preparation for the first human mission to Mars begins with the launch of a cargo mission to Mars in 2014 for this architecture. This flight emplaces a pressurized rover, a habitat and an atmosphere reduction plant at the selected site. The atmosphere reduction plant takes in the carbon dioxide, reacts it with an initial store of hydro-

gen brought from Earth and generates and stores modest quantities of methane and oxygen, gases which would be used as sources of energy.

A rover, powered by methane/oxygen fuel cells, is used for local exploration, and is refuelable from the products of the resource plant. The verification of using in situ fuel and the refueling operation itself are major activities next to the primary activity of exploration. The first human mission to Mars is in 2016, two years later than the other three architectures, to allow sufficient time for development of a lunar resources capability. Once on Mars, surface exploration, as described above, will be the theme of operations.

Mars Next Operational Capability.

The Next Operational Capability in this architecture emphasizes tests and demonstrations of in situ resource use on the Martian surface to support long term human presence. The second expedition to Mars follows the pattern established by the first; a cargo flight leaves in 2016 and places an expansion unit to the resource plant and a small greenhouse, all at the previous site. This provides a significant food and fuel production capability. The Martian greenhouse is provided to augment the food supply and improve the quality of life for humans on the surface. It is also important as a test of whether human activity on Mars could become self-sufficient. This second expedition is the last specifically detailed in this architecture, and it provides a Next Operational Capability.

Near-Earth Asteroid Option.

As in Architecture II, an exploratory visit to a near-Earth asteroid is an option. The emphasis in this case is not primarily exploration but the characterization and examination of an asteroid as a source of valuable, useful material.



Exploring the Moon

As the Synthesis Group developed architectures, it became clear that several technological and operational alternatives generated in the Outreach Program could enhance the performance, reduce the cost or shorten the schedule, but usually with an increase in risk. Conversely, there were technological and operational concepts proposed that were lower in risk but also lower in performance potential. These were not utilized in an architecture but should not be disregarded. Other alternatives recommended had questionable payoff or were beyond the time scale of this investigation. Representative examples are addressed under the following categories:

- 1) Backup options
- 2) Relevant concepts that should receive further considerations as future system architecture studies are conducted and technology matures
- 3) Futuristic concepts or technologies outside the time scale of the Synthesis Group architectures (2020) which do not warrant substantial investment

Backup Options

Chemical Propulsion

Chemical propulsion for Mars transfer vehicles provides a backup system to nuclear thermal rockets. Given the lower performance of chemical propulsion for the Mars mission, the primary reason for considering it is to provide an option if the high specific-impulse nuclear thermal propulsion option does not become available.

Chemical propulsion offers at best half the specific impulse available from a nuclear thermal rocket; as a result, a Mars mission using it will require much more fuel. The lower specific impulse of chemical propul-

sion systems can be somewhat mitigated by using long stay-time (1,000 day total mission duration class) trajectories from the start, rather than just for the later missions (as preferred for the baseline approach). This leads to lower Earth orbit masses which are significantly reduced from the 500 day class missions (but still 50 to 100% greater mass to low Earth orbit than for the comparable nuclear thermal rocket mission). Tradeoffs with regard to departure dates, elliptical orbits around Mars, and reductions in dry mass become much more critical in attempting to develop reasonable total system masses for chemical propulsion missions.

Nuclear Electric Propulsion

Nuclear electric propulsion was seriously considered for the Mars cargo vehicle. Its high specific impulse was very attractive for this mission just as its low thrust made it less attractive for the piloted mission. One consideration that was given to the nuclear electric propulsion technology was that it might easily evolve from the surface nuclear power plant that will have to be developed. However, when considering only the Mars Initial Operational Capability and Next Operational Capability, it was decided to baseline the nuclear thermal rocket.

Within the 2020 timeframe, an option exists to use nuclear electric propulsion on later lunar missions to shuttle cargo back and forth between low Earth orbit and low lunar orbit or Lagrange transit. The decision to exercise this option is deferred until the nuclear surface power development is well underway and architectural decisions result in sufficient demand for shuttling cargo.

Aerobrake Technology

Aerobrakes are devices which use atmospheric drag instead of propulsion system thrust to modify the velocity and trajectory of a space vehicle. (When aerobraking is used for

direct re-entry, the term aerodescent is used; this type of technology has been demonstrated on the Space Shuttle, Apollo, and Department of Defense re-entry vehicles.) Aerocapture is the term used when aerobrakes are utilized to capture a transit vehicle into a planetary orbit. This technology was used by NASA in the *Report of the 90-Day Study on Human Exploration of the Moon and Mars*, for both Mars orbital insertion and for Earth orbit insertion following lunar or Martian missions. The main advantage of aerocapture is the significant reduction in propellant required as compared to a Mars orbit insertion using all propulsive braking. However, there are some major disadvantages associated with aerobrakes.

The desired short transit times for Mars missions result in high entry velocities (greater than 13 km/s) which severely stress the aeroshell design. Entry velocities at Mars are much greater than Apollo entry speeds. As the entry velocity increases, the entry corridor for aerocapture shrinks, thermal and structural loads increase and precise navigation requirements become more demanding.

Present aeroshell designs utilize low lift-to-drag ratios to increase stability and decrease aerodynamic heating. These designs impose severe constraints on spacecraft design. The spacecraft must fit into the wake cone to minimize damage from convective heating and must be protected from radiative heating. The spacecraft structure must also be designed to attach to the aeroshell and be strengthened to absorb deceleration loads. The aerothermodynamics of the wake flows cannot be accurately predicted at present, so the design process must include substantial hypersonic testing. The deceleration profile must be tailored to the crew and structured limits, which dictates a complex active flight control system for the aeroshell-spacecraft vehicle.

The existing Deep Space Network is not sufficiently accurate for pre-

capture navigation updates. As a result, either Mars navigation satellites or surface beacons would be required. In addition, unknown Mars atmospherics could adversely affect the aeroshell and flight control system design. Atmospheric density could vary by a factor of two or three and is unknown at atmospheric entry unless there are weather satellites at Mars. Further, the extent of possible dust storm erosion on the thermal protection system is not well known. Finally, if propulsive braking propellant is eliminated by using aerocapture, it will not be available for contingency trans-Earth injection burns in the event of a mission abort.

In addition to the myriad problems that aerobrakes will encounter at Mars, extensive on-orbit assembly is required using either extravehicular activity or robotics. The thermal and structural integrity of the assembled structure, as well as center of mass, cannot be easily verified.

NASA's current Aeroassisted Flight Experiment will provide useful technology data that can have potential aerobrake applications for Earth entry and may have application for Mars precursor missions, in cases where the entire vehicle would be assembled and integrated on the ground before launch. This utilization of an aerobrake could save the program from manifesting the mission on a heavy lift launch vehicle, allowing it to be flown on a smaller expendable launch vehicle.

Relevant Concepts

Early Trip to Mars — Nuclear

The Mars Exploration architecture baselines its first piloted flight to Mars in 2014. An aggressive Mars option exists using an accelerated nuclear thermal rocket development program that would move this date up by six years to 2008. Because of the synodic relationship between the Earth and Mars, this is the last window prior to 2014 that should be considered. Such

a program would require significantly increased up-front funding and an optimistic schedule. The required nuclear thermal rocket program to meet this schedule is shown in Figure 1.

Lagrange Point Assembly

Instead of staging directly from low Earth orbit to Mars, another recommendation is to use the Earth-Moon L1 Lagrange point, as shown in Figure 2, as an assembly node. This approach is especially attractive if in situ lunar fuel becomes available, which would lower the requirement for Earth to orbit transportation of fuel.

Mars-bound vehicles departing from the L1 Lagrange point require

on the order of 2.6 km/s less delta-V than the same vehicle departing from low Earth orbit; however, 4.0 km/s must be applied to get the vehicle components to the Lagrange point. Using the L1 point as a staging point for Mars missions may have utility if reusable vehicles are specified for multiple Mars missions. In addition, it may be beneficial for storage and disposal concerns when using nuclear thermal rockets.

Some disadvantages include a more severe radiation environment, thermal considerations due to a continuous sunlight, and increased total mission mass. Use of in situ fuels would necessitate a lunar infrastructure of unknown complexity. The use

Figure 1

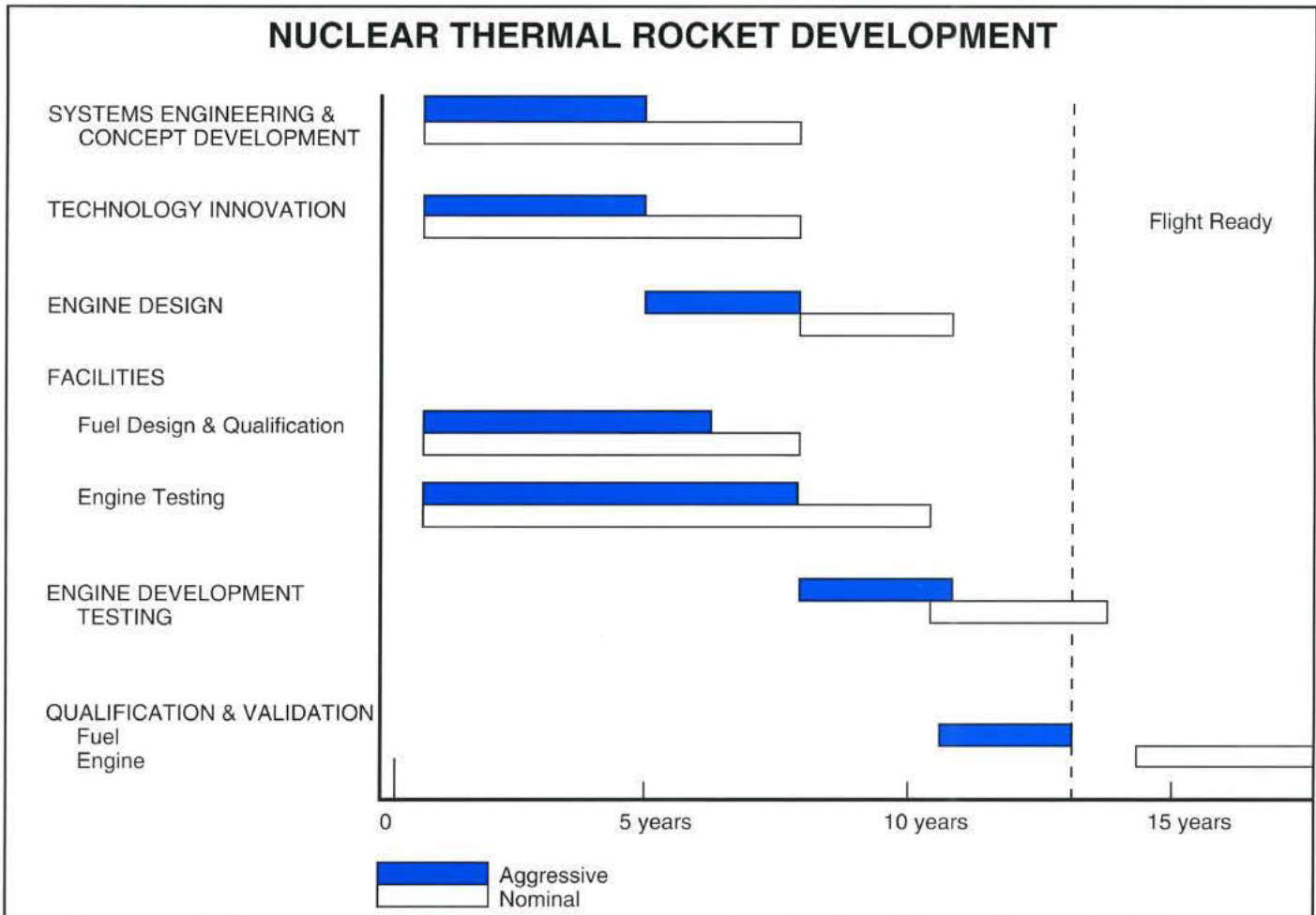

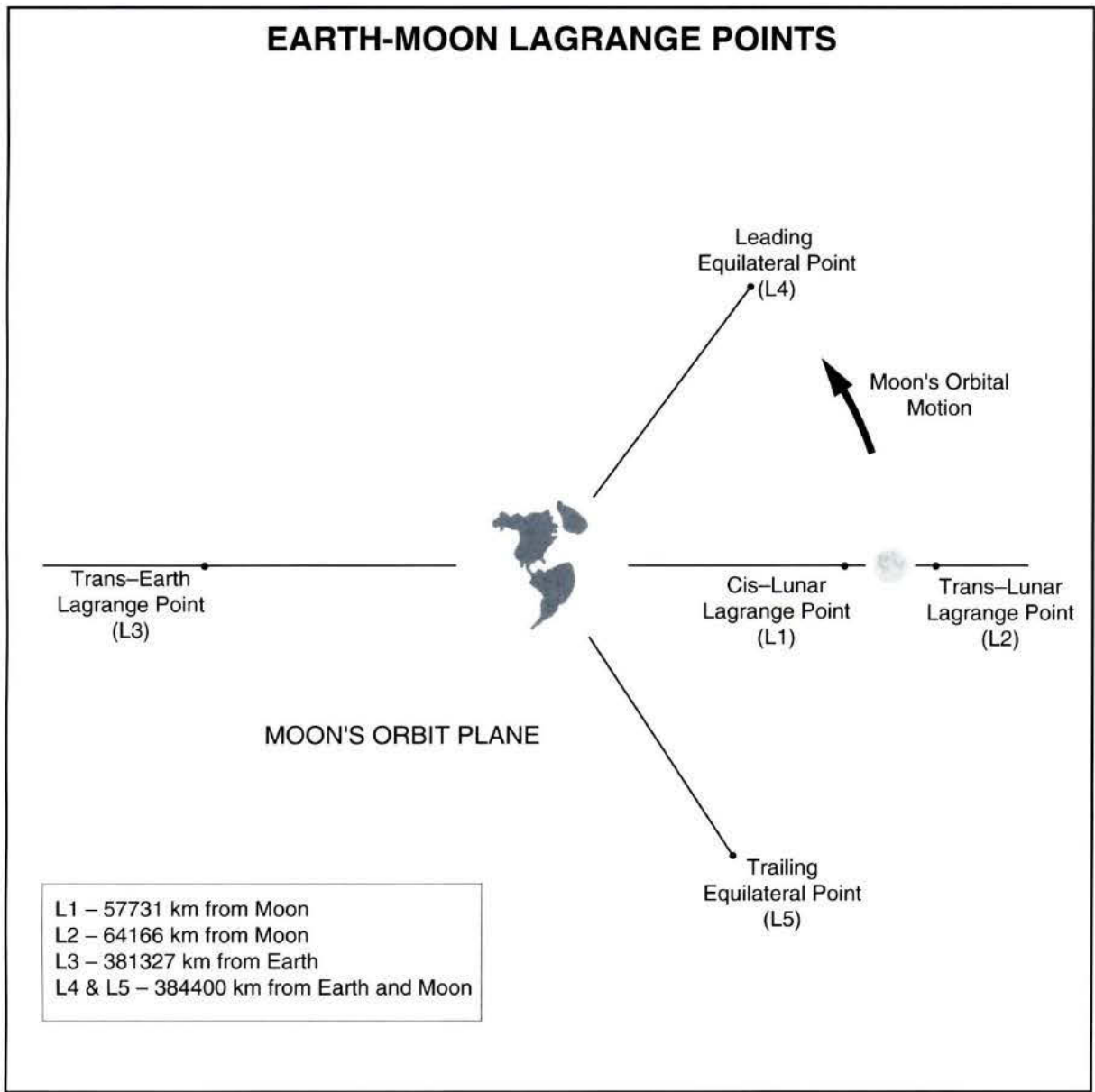

of the L1 Lagrange point also requires the development of new rendezvous techniques.

Elliptical vs. Circular Martian Parking Orbit

Piloted Mars missions generally use circular parking orbits as staging sites, orbiting vehicles there while the crew goes down to the surface. The choice of this orbit has an important effect on

mission mass and on the accessibility of various landing sites.

The incentive to use elliptical parking orbits, depicted in Figure 3, stems from a desire to reduce mass. For operational reasons, such orbits are usually long, having a low periapsis and a one Earth-day period. The Mars vehicle has an easier time entering and then departing from these loosely bound orbits than it does for

Figure 2

low circular orbits; a delta-V of 1.2 km/s can be saved from each propulsive maneuver burn. This advantage is reduced somewhat by the extra maneuvers discussed below, yet still allows typical reductions in low Earth orbit mass of 15% for nuclear propulsion and 30% for chemical.

The incentive to use circular orbits stems from their operational simplicity. The orientation of parking orbits must be carefully matched to the desired interplanetary trajectories; hopefully, a single orbit satisfies both the entry and exit conditions. This is generally possible for circular orbits since only their plane matters. But for elliptical orbits, both the plane and the apsidal (major axis) orientations must be matched. This often cannot be done, so the entry orbit must be shifted to prepare for departure. Access to and from the surface is also

more restricted when using elliptical orbits. The ascent vehicle needs more fuel, and the orbit's apsidal latitude must match that of the surface site. These extra-orbital and ascent maneuvers complicate the mission and somewhat reduce the potential mass savings.

Tethers

Space tethers are long, lightweight structures that could be used in space in several ways. The physics of tethers is simple and straightforward, and tethers in space have been studied for many years.

Tethers are based upon the principle that elongated objects in orbit align themselves vertically. Objects at the ends of the tether experience inertial forces not felt by the freely orbiting body. The differences of forces along the length of the tether give rise

Figure 3

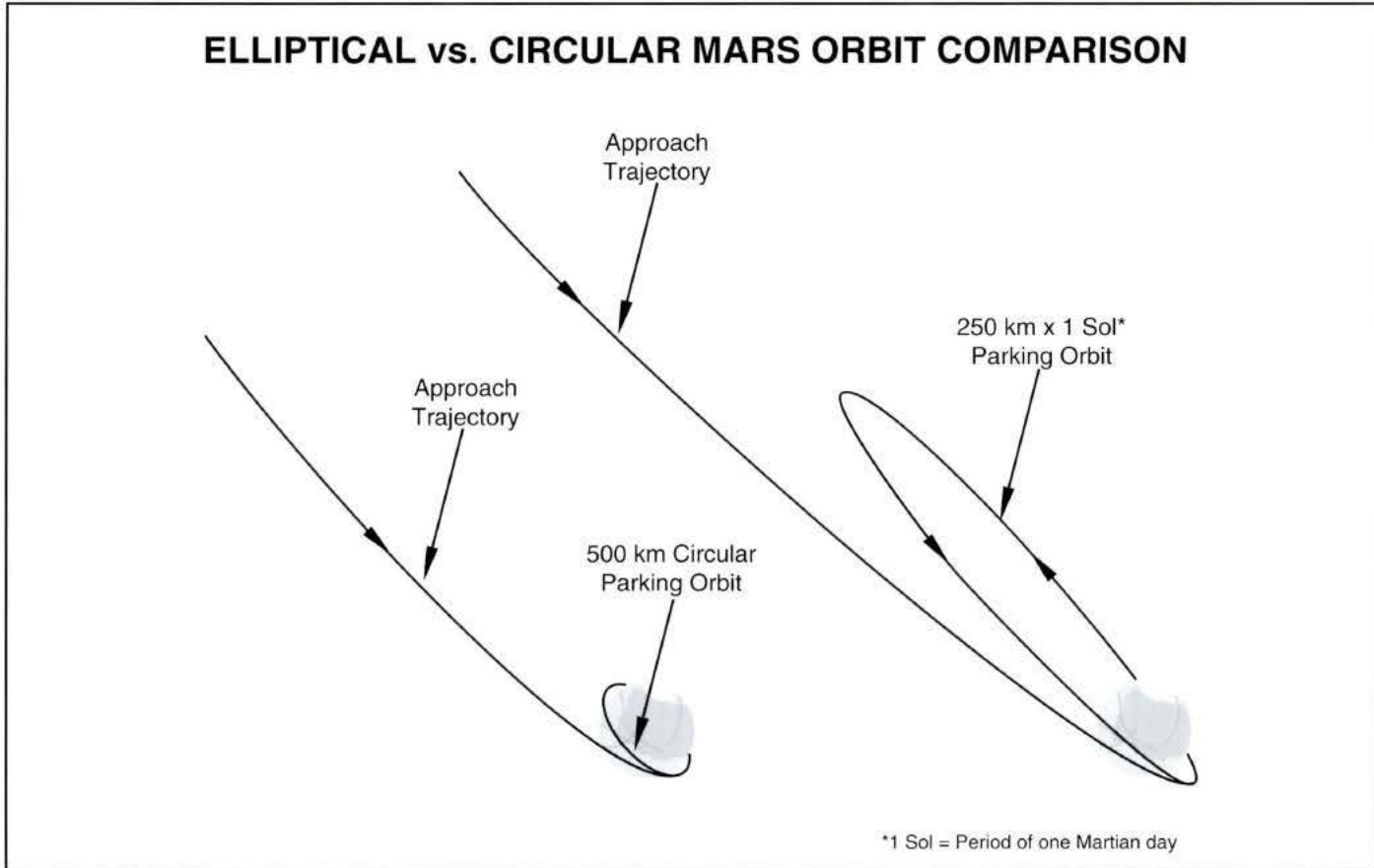

to a number of applications. A few examples are: use of a tether to generate electricity, use of a tether to exchange momentum from one object to another, tethering an orbital body to a higher or lower orbit, or to pick up objects near a surface such as the Moon. Tether designs are theoretical at this point and lack flight verification. Operations are, however, believed to be very complex. A tether experiment on the Space Shuttle is scheduled in the near future and may help predict their utility for the Space Exploration Initiative.

Futuristic Concepts

Cyclers

Earth-Mars cycling transfers are interplanetary trajectories which allow vehicles to return repeatedly to the vicinity of these planets by using gravity assists. The cycling transfer vehicle would be reusable over many missions, allowing the crew to go separately from cargo via a hyperbolic rendezvous between high-speed "taxi" and the cycling transfer vehicle.

The cycler concept requires an infrastructure investment beyond that contained in the Mars phase of all four architectures; the infrastructure investment to enable the cycling concept becomes a viable option only with a higher mission rate.

Gemini XII Tethered Agena



Technology requirements have been addressed in seven functional areas. Subsequent sections will discuss each of the functional areas in terms of requirements, the options available, baseline decisions and recommendations for development programs. The physiological aspects of the Initiative which cross several functional areas are covered in the Life Sciences chapter. The seven functional areas are:

- 1) Propulsion
- 2) Power
- 3) Extravehicular Activity
- 4) Life Support
- 5) Planetary Surface Systems
- 6) Spacecraft
- 7) Communications, Control and Navigation

Propulsion

Requirements

Propulsion requirements for the Space Exploration Initiative are needed for: Earth-to-orbit, interplanetary transfer (crew or cargo), descent and ascent.

The Earth-to-orbit systems have high thrust and large payload capacity requirements with a minimum of 150 metric tons and with designed growth to 250 metric tons to low Earth orbit.¹

Systems for ascent and descent missions at both the lunar and Martian surfaces require throttling, high reliability, and long term cryogenic storability. Initial lunar requirements are met by current storable propellant engine technology.

The three most important parameters that affect propulsion requirements for human Mars missions are transit time, initial mass to low Earth orbit, and launch window opportunities.

Options

In the time period of interest, propulsion can be supplied using chemical, nuclear thermal and nuclear electric.

Chemical Systems. Chemical propulsion systems are either liquid, solid or some hybrid of the two. Liquid systems are further categorized as either storable or cryogenic. Storable chemical systems consist of both a liquid fuel and an oxidizer, such as hydrazine and nitrogen tetroxide, which can be stored in ordinary tanks over long periods and over a range of temperatures without decomposition or a change of state. The specific impulse for these combinations is relatively low, being in the 240 to 280 second range. Conventional cryogenic chemical systems, such as liquid oxygen-hydrogen, are in an advanced stage of development. The specific impulse for these systems is in the 350 to 460 second range. A liquid oxygen-hydrogen Space Shuttle Main Engine

Table 1

Chemical System Characteristics		
	Cryogenic (Specific Impulse)	Storable (Specific Impulse)
Liquid	LOX/LH ₂ (375s) LOX/RP-1 (281s) LOX/UDMH (295s) F ₂ /H ₂ (393s) F ₂ /N ₂ H ₄ (344s) F ₂ /UDMH (328s)	N ₂ O ₄ /RP-1 (262s) N ₂ O ₄ /N ₂ H ₄ (279s) N ₂ O ₄ /UDMH (273s) ClF ₃ /N ₂ H ₄ (280s) ClF ₃ /UDMH (266s)
Solid	N/A	NH ₃ ClO ₄ /Polybutadiene (290s)
Hybrid	LOX/HTPB (299s)	NH ₃ ClO ₄ /Polybutadiene (290s)

is rated at 365 seconds at sea level or 456 seconds in a vacuum. Table 1 lists some typical propellant combinations and specific impulse values based on 600 psi chamber pressure exhausting to 14.7 psi ambient.

Current heavy lift launch vehicle concepts are concentrating on liquid oxygen-liquid hydrogen for main booster engines, together with advanced solid rocket motors for liftoff augmentation. Experience has shown that large liquid hydrogen and oxygen engines have been expensive to develop and operate. A liquid oxygen-hydrogen propellant is not an attractive option for the first stage of a heavy lift launch vehicle because of the large tank volume and the safety concerns of using hydrogen below an altitude of 100,000 feet.² A new launch vehicle capability will need to be developed for both the Space Exploration Initiative and other Department of Defense and NASA space launch requirements; alternate propulsion system concepts should be considered for these applications.

The Apollo Saturn V launch vehicle program developed the F-1 liquid oxygen-kerosene (RP-1) powered booster engine, shown in Figure 1, which delivered 1.5 million pounds of thrust at sea level. Flight reliability was demonstrated to be 100%. Although it was never flown, an upgraded version delivered 1.8 million pounds of thrust at sea level. The potential exists for a heavy lift launch vehicle booster to support the Space Exploration Initiative using proven and reliable technology. The use of F-1 engines as a first stage and strap-on propulsion stage of a new heavy lift launch vehicle is extremely attractive from cost, schedule and safety viewpoints. Using F-1s for booster engines, coupled with liquid oxygen-hydrogen upper stage engines (upgraded J-2s or space transportation main engines), could result in establishing heavy lift launch vehicle capabilities by 1998. The Soviet Union, which currently has heavy lift

capabilities of approximately 100 metric tons to low Earth orbit, has relied on liquid oxygen-kerosene technology (RD-170 engine) for the booster stages with liquid oxygen-hydrogen for the upper stages.

In addition, the National Aerospace Plane program has made significant progress in materials and system technology in the last five years. Propulsion and material technologies from the National Aerospace Plane program have led to the Strategic Defense Initiative Office single-stage-

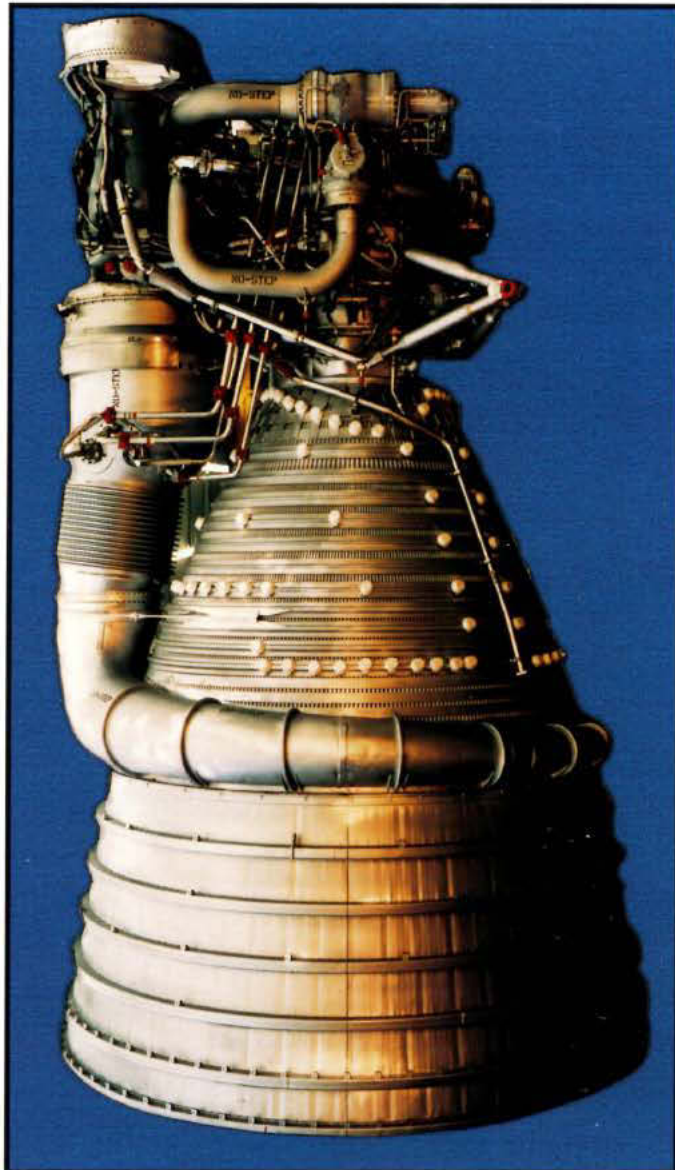

Figure 1:
Apollo Saturn V
F-1 Engine

to-orbit concept. The National Aerospace Plane program should be vigorously pursued. The single-stage-to-orbit concept should be carried forward to demonstrate concept feasibility. Both of these efforts could hold promise for a cost effective personnel launch system to low Earth orbit.

Nuclear Systems. The nuclear thermal rocket is a device which uses a nuclear reactor to heat propellant to high temperatures. The propellant is then expanded by a supersonic nozzle to produce thrust much in the same manner as a conventional rocket motor, as shown in Figure 2. However, since the nuclear thermal rocket can use a low molecular weight propellant (usually H_2), heated to high temperatures, substantial increases in

performance over chemical systems are possible.

Nuclear thermal rockets underwent substantial development in the 1960s and the early 1970s under the Rover/Nuclear Engine for Rocket Vehicle Applications program. A series of full power reactor/engine tests resulted in propellant temperatures in excess of $2,700^\circ K$ and a specific impulse of 845 seconds. One 1,125 MWt reactor power test was run continuously for one hour. In addition, a reactor power test demonstrated 28 automatic start-up/shut-down sequences and a thrust level of 250,000 pounds was demonstrated. Although no integrated rocket system was ever flight qualified or flown, the program did generate substantial test experience prior to program termination in 1972. Based on experience gained in this program and the Space Exploration Initiative requirements, nuclear thermal rockets, with further development, are the choice propulsion technology for the interplanetary phase of the Mars mission.

Since 1972, advances in materials and fuel technology hold the promise for higher temperatures leading to still higher performance engines. Newer concepts, such as the compact particle bed reactor, offer potential for high power density reactor cores which could lead to substantially higher integrated thrust-to-weight ratios. A high thrust-to-weight ratio engine would be particularly attractive for a second generation upper stage of an advanced heavy lift launch vehicle.

To provide propulsion for Moon and Mars cargo missions, where transit time is not an important constraint, low thrust nuclear electric propulsion systems are attractive because of their very high performance levels; their specific impulses range from 3,000 to 10,000 seconds. Although the technology is usually described as new, some 30 electric thrusters have been flown in space to date.

Figure 2

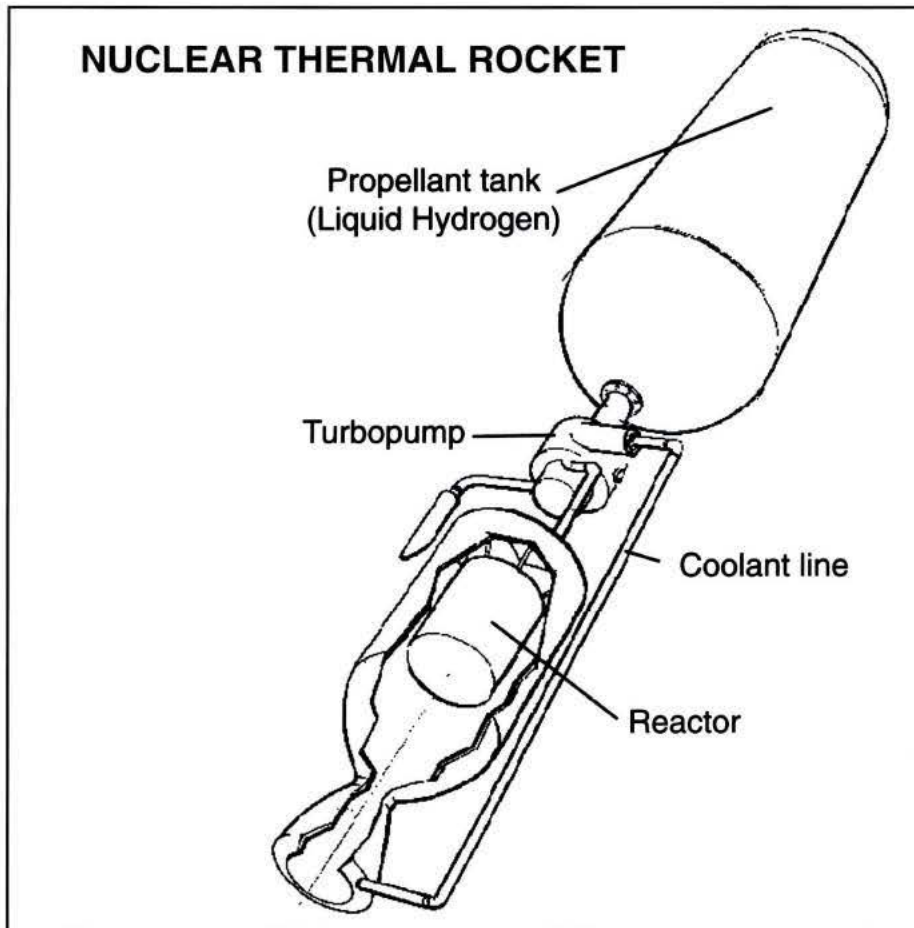

While the development of nuclear electric thrusters is moderately well advanced, the main issue in the technology status of these systems is the lack of space-qualified nuclear power systems in the 1 to 5 MW range. A robust technology program to develop multi-megawatt nuclear systems for both surface and space application could result in the use of nuclear electric propulsion for Mars cargo missions. The major advantage of these systems is the very low propellant requirements for interplanetary missions. This directly translates into a cost savings due to a decrease in the amount of propellant needed in low Earth orbit.

Promising nuclear electric thrusters include ion and magnetoplasmadynamic engines. Ion engines use a noble gas such as Xenon or Argon as a propellant. Ion systems have specific impulses approaching 10,000 seconds, but this benefit is offset by a low thrust level. Magnetoplasmadynamic thrusters have demonstrated high performance with specific impulses ranging from 3,000 to 6,000 seconds.

Baseline

Chemical systems, such as liquid oxygen-hydrogen or liquid oxygen-kerosene (RP-1), are the primary high thrust systems for Earth-to-orbit operations and lunar missions.

For low thrust missions such as lunar ascent and descent, storable liquid systems are utilized (nitrogen tetroxide-unsymmetric dimethylhydrazine, etc.). Numerous storable propellant systems have demonstrated the necessary throttling for ascent and descent applications. High performance systems such as liquid oxygen-hydrogen need to demonstrate long term storability.

Parametric studies for piloted Mars transfer missions show that chemical propulsion is an undesirable option since the initial mass to low Earth orbit requirements exceed 1,100 metric tons in addition to providing limited launch opportunities and

requiring longer transit times. The piloted Mars transfer vehicle uses a nuclear thermal rocket propulsion system with a high thrust to weight ratio (approaching chemical propulsion systems). The initial Mars cargo missions will also use the same high thrust-to-weight nuclear thermal rocket propulsion system and provide further inflight verification prior to the piloted flight. Follow on cargo missions may use nuclear electric propulsion.

Near term Earth-to-orbit and lunar cargo transfer will use a conventional cryogenic chemical propulsion system.

Development Programs

Propellant management in zero gravity has several technology problems and issues which need to be resolved, such as tank staging and whether to use wet or dry transfer. To meet the timetable for returning to the Moon, handling experiments should be completed by 1999 and, therefore, be initiated soon. It must be emphasized that although no new physics is involved and all propellant management issues are engineering problems only, actual demonstrations will be a significant challenge.

Advanced development in chemical propulsion technologies, such as the large pintle-controlled injector and the liquid/liquid platelet injector concept, holds promise for reductions in cost without major performance penalties.

In order to provide a flight qualified nuclear thermal rocket for the 2014 Mars mission, an aggressive development program must be initiated.

Testing of an integrated nuclear thermal rocket presents a challenging engineering and political problem. The safety issues regarding operation are principally concerned with accidental release of radioactive material. Location of potential Department of Energy ground test sites are very isolated and the amount of radioactive

Nuclear Thermal Rocket Performance Goals

- **Engine specific impulse \geq 925 s**
- **Thrust-to-weight ratios approaching those of chemical systems**
- **Start/stop cycles \geq 10**
- **Highly reliable, environmentally sound, and inherently safe**

Figure 3: NERVA Engine

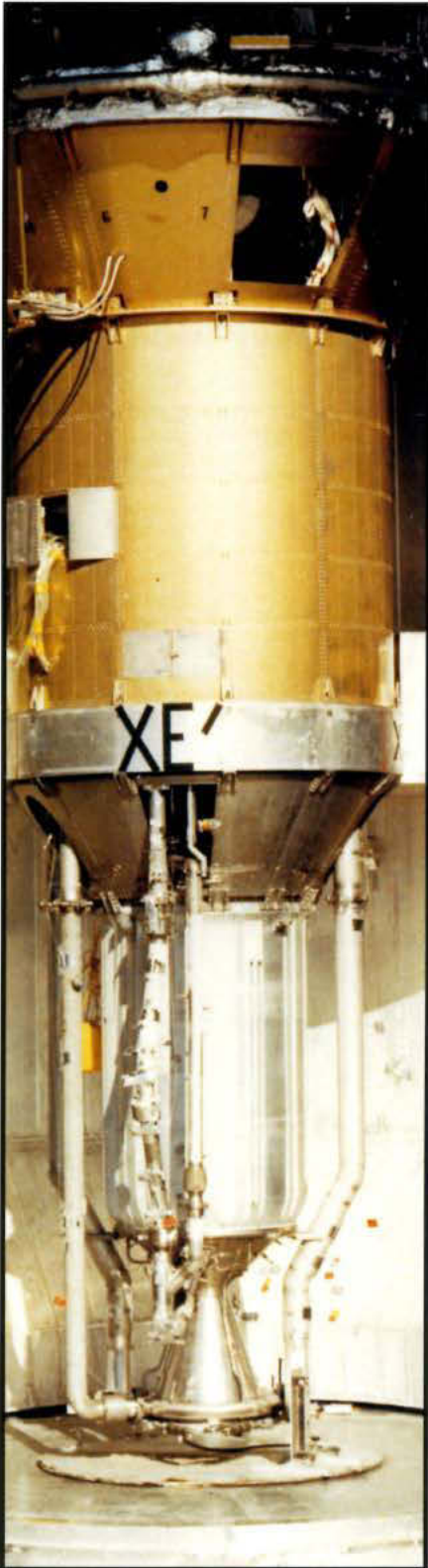

material in the engines assures that even if an accident released 100% of the fuel, radiation levels outside the test site boundary would be below accepted national nuclear safety standards. In addition, as demonstrated in the Rover/Nuclear Engine for Rocket Vehicle Applications (NERVA) program (Figure 3), exhaust scrubbers can further guard against the possibility of inadvertent release. Development tests can be designed to meet all applicable nuclear safety requirements and licensing criteria.

The issue of using a nuclear rocket in a flight test is more complex. Social and political perceptions, not just technical realities, are involved. Design of an engine is such that under normal operating conditions, there is virtually no radioactivity in the exhaust stream, as all fission products are contained within the fuel particles. There is a minimum radiation risk prior to the time the reactor is run for the first time, which occurs at trans-Mars injection, leaving Earth orbit. Thus, while the reactor is on the launch pad, it contains only the natural radioactivity levels associated with the uranium fuel.

When the engine is operated in space to provide thrust, the operating time is relatively short compared to terrestrial power reactor systems. This method of operation produces fission byproducts which are predominantly short-lived. The radioactivity in the engine after completion of thrust is far less than contained in a comparable terrestrial power reactor. However, the decay of these radioisotopes releases secondary radiation such as gamma rays. It is the radioactivity associated with this process which poses minimal and short-term consequences in a terrestrial accident situation. Use of nuclear engines for upper stages and missions beyond Earth orbit permits further minimization of risk by allowing a wider selection of trajectory profiles and abort options.

The amount of radioactive material in the rocket engine prior to the nuclear engine's start would be orders of magnitude less than radioisotope thermoelectric generators which have already been safely launched (most recently, Ulysses). The issue of meeting all the necessary safety and environmental standards will be a substantial challenge. The program must be dedicated to this aspect if the technology is to gain public acceptance.

Power

Requirements

The functional electrical power requirements are shown in Table 2. Transportation to the Moon requires power for about seven days for the round trip in addition to time in lunar orbit, whereas transportation to Mars involves trip times on the order of a year plus orbital and surface operations of up to two years. In cases where solar flux is very high, great care must be taken to control thermal heating. This results in continuous rotation of the spacecraft to spread the thermal load and affect orientation of solar panels and radiators.

Surface activities needing power include habitats, laboratories, base power and vehicles. Habitats must have their own highly reliable power source for safety. Base power includes power for mining, in situ operations, fabrication, emergency power for habitats and power for regeneration of fuel cells. Habitat power must be highly reliable, greater than 99.5%, while base power can be about 95% reliable. Power units should be made operational with a minimum of support activities, have lifetimes compatible with the base, be serviceable and, if nuclear, be refuelable and disposable. Evolutionary system designs are preferable to specific point designs without growth potential.

Options

Power can be supplied using electrochemical energy storage devices, pho-

POWER REQUIREMENTS

Functions	Mars Power	Moon Power	Suggested Technology
Transportation			
Spacecraft Piloted	to 20 kw	to 30 kw	Fuel cells (Moon) Nuclear/photovoltaics (Mars)(1)
Cargo	5 kw	5 kw	Fuel cells (Moon) Photovoltaics (Mars)
Lander	20 kw	20 kw	Fuel cells (w/wo photovoltaics)
Electric propulsion	to 5 Mw	to 5 Mw	Nuclear
Surface Activities			
Day only	20 kw		Photovoltaics
Habitat/lab			
Initial Operational Capability	to 30 kw	to 50 kw	Photovoltaics or nuclear (1)
Next Operational Capability	50 kw	100 kw	Nuclear
Base Power			
Initial Operational Capability	to 100 kw	to 100 kw	Nuclear
Next Operational Capability	to 800 kw	to 1 Mw	Nuclear
Rovers			
Unloader/Construction	240 kw-hr	240 kw-hr	Fuel cells (2)
Pressurized			
Initial Operational Capability (per trip)	1900 kw-hr	1900 kw-hr	Fuel cells (2)
Next Operational Capability (per trip)	4800 kw-hr	4800 kw-hr	Fuel cells (2)
Unpressurized	100 kw-hr	100 kw-hr	Fuel cells (2)

(1) Depends on final power level

(2) In situ methane and oxygen produced on Mars may substitute for fuel cells.

tovoltaic energy, radioisotope decay or nuclear fission reactors.

Batteries that could be considered for energy storage include the current generation nickel-cadmium and nickel-hydrogen and also the development of sodium-sulfur. Their current performance for space-qualified systems is 20 W-hr/kg with projected performance by the year 2000 of 100 W-hr/kg or greater.

Regenerative fuel cells currently deliver 250 W-hr/kg. By the year 2000, this could be improved to 1 kW-hr/kg for regenerative fuel cells and two to three times this for non-regenerative fuel cells. Regeneration elements include electrolyzers and refrigerators to reconvert the water from the fuel cells back to liquid hydrogen and oxygen.

Photovoltaic arrays currently deliver approximately 21 W/kg in sunlight at 1 astronomical unit (93 million miles); by the year 2000, the goal is to exceed 200 W/kg.

Photovoltaic systems with energy storage continue to be the primary power system for Earth orbital operations. System performance using batteries is on the order of 3 W/kg; by the year 2000, projected improvements should achieve 10 W/kg. For continuous lunar surface operations with two weeks of night using fuel cells, current technology is 0.7 W/kg, which includes fuel. This can be improved to about 3 W/kg; by the year 2000 using the improved solar arrays and regenerative fuel cells. If locally produced oxygen is available, the weight of the fuel transported

Table 2

from Earth can be significantly reduced. For Mars power systems, the solar flux is less than half that at Earth, but the nights are comparable in length to those on Earth, lowering the energy storage requirement with respect to the Moon. For continuous loads at Mars, power density using today's fuel cells is 3 W/kg. Advanced technology by the year 2000 could increase this to 27 W/kg. Dust storms will reduce photovoltaic performance on Mars.

Radioisotope power sources have been the primary electrical power source for robotic planetary exploration. These units have used thermoelectric converters to supply hundreds of watts of power in units called radioisotope thermoelectric generators. Current performance for these units is 7 W/kg. By the year 2000, programs are underway to improve this to about 8 W/kg. Cost and Plutonium-238 availability are the major restrictions on expanded use of radioisotope thermoelectric generators. Larger and more efficient converters using rotating machinery can triple the efficiency and reduce costs. These units, called dynamic isotope power systems, could be ready by the year 2000. However because of the limited availability of Plutonium-238, only about 2 kW/year can be produced. Dynamic isotope power systems are not envisioned to play a major role in the Space Exploration Initiative.

U.S. space nuclear fission power plants are currently under development. The SP-100 Program is developing the technology for 10s to 100s of kW using uranium nitride fuel in a liquid metal-cooled reactor. It includes thermoelectric converters for the regime below 100 kW and Rankine or Brayton dynamic cycles for the higher power regime. The goal is to demonstrate 25 W/kg at 100 kW. In addition, the United States has been demonstrating thermionic fuel element devices, while the Soviet Union has flight tested thermionic

reactors in space for up to a year and has projected three-year lifetimes in ground testing. Thermionic reactors can be demonstrated by the year 2000 as an alternate or complementary technology to SP-100. Performance is similar; however, thermionic power system radiators will be four to six times smaller as a result of the heat rejection temperature being 200°K higher and the efficiency two to three times greater.

Nuclear fission power plants for electric propulsion are not currently under development; these had been studied as part of the Nuclear Multimegawatt Power Program. Performance projections are better than 100 W/kg at 2.5 MW (two units would be used for 5 MW spacecraft). Higher radiator temperatures are needed than in the SP-100 regime; many candidates exist, including Rankine cycles, Brayton cycles, and thermionic reactors.

Power beaming is a technology to distribute power to remote sites from the generation source. Either radio frequency generators or lasers could be used. By the year 2000, radio frequency generators are projected to be about 60% efficient and lasers near 20%. However, laser systems require smaller receivers that are relatively lightweight and easier to install in space applications. The cost of installed power is projected to be about half that of locally generated power if one considers that the source will be available free from some other application, such as nuclear propulsion.

Spacecraft power for lunar missions is determined by the duration of the trip. For systems sized for seven days of operation, energy storage devices are the logical power options. Fuel cells are preferred over batteries because of the projected mass savings. In addition, fuel cells can be modularized to provide redundancy in case of malfunctions.

The options for spacecraft power for Mars missions with several years'

lifetime are solar photovoltaic systems and nuclear power. Both options depend on future developments. Advanced photovoltaic systems are being developed so this option will be available. With the recommended nuclear option, a demonstration technology competition should be pursued between SP-100 and thermionic reactors prior to selecting the flight system. In either case, an extremely reliable power system is needed.

For Mars cargo missions, the required power levels are sufficiently low that the lighter photovoltaic power systems are favored over nuclear power systems.

For the landers, mission duration is measured in hours. Energy storage in the form of fuel cells is favored because of their light weight and because they will also be utilized for lunar spacecraft. The fuel cells could be supplemented by fold out photovoltaic arrays to increase their operational time.

For electric propulsion cargo missions, both lightweight solar arrays (energy storage is not needed) and nuclear were considered. A major difficulty with solar arrays is the large size, 6,000 m² for 5MW at Mars orbit. Construction, costs and orientation problems are exceedingly formidable for solar photovoltaic arrays at these power levels.

Moon and Mars represent different power system challenges. For daytime stays on the Moon, lightweight, easily deployed photovoltaic panels are the minimum mass option over nuclear or energy storage.

For one full lunar-day stay (28 Earth days) on the lunar surface, photovoltaic power systems with energy storage and nuclear systems are the prime candidates. For a 25 kW habitat load, nuclear systems as compared to solar photovoltaic systems will weigh one-fifth as much and save 8,000 kg on the lunar surface. Continuous base power that can increase to 1 MW will weigh about 12,500 kg using nuclear

power, versus 330,000 kg using photovoltaics with energy storage.

For mobile surface power, dynamic isotope power systems, batteries, fuel cells and in situ methane and oxygen (Mars only) were considered. Since sufficient Plutonium-238 is not available to power all the projected rovers, an alternative is needed. Therefore, fuel cells are the candidate of choice, but regeneration equipment would be needed to reuse the water as oxygen and hydrogen. This can be done on the vehicle or at the base. Base power would be used as the energy source for regeneration though the vehicles could include a roll-out solar array for emergency power that can be powered from the Sun or by beaming from the base. With the validation of in situ methane and oxygen production on Mars, these fuels can be used to provide the capability for longer distances and higher speed rovers.

Baseline

For Mars, nuclear power is recommended over photovoltaics due to the mass savings. The nuclear units will be developed to Mars specifications, and the Moon will be used to validate the deployment concept and demonstrate safe and reliable operation. On Mars, having backup between the habitat and base power is necessary for safety, since a quick return home is not possible.

Nuclear power systems to a megawatt level can provide base power, including power for in situ resource processing, refueling surface vehicles, and emergency habitat power. These systems will be designed for both the Moon and Mars environments, with a specific power of greater than 100 W/kg at 1 MW. They need to be deployed with a minimum of robotic or human operations. Lifetimes must be on the order of 30 years.

Advanced regenerative fuel cells could provide power for lunar spacecraft, landers, and surface vehicles,

with performance greater than 1 kW-hr/kg.

Nuclear power units (10 to 100 kW) can provide power for Mars spacecraft and lunar and Mars surface habitats. These systems should have a specific power greater than 15 W/kg at 25 kW, reliability greater than 99.5%, passive conversion and no single failure points.

Advanced solar photovoltaic arrays, with specific powers greater than 200 W/kg, can provide power for spacecraft and daytime surface operations.

Development Programs

Each nuclear power system outlined above would require a major development effort. To begin, the current SP-100 and thermionic programs should be restructured to meet Space Exploration Initiative requirements. Furthermore, all technology options should be considered. Technology down-selections should be based on demonstrated performance, safety and reliability. The benefits provided by nuclear power systems are extremely high and are key enablers for many Initiative activities; however, new efforts to develop space applications of nuclear power should be structured to take advantage of lessons learned from the SP-100 program.

Advanced regenerative fuel cells can be developed by the year 2000. The cost is low with wide application to critical surface systems such as landers and rovers.

Solar photovoltaic arrays could play a wide range of roles in the Initiative. Increasing the efficiency and decreasing the weight of solar arrays will continue to pay high dividends for both space- and Earth-based applications.

Power beaming for surface-to-surface power distribution may greatly reduce the mass of rovers and other mobile surface systems, assuming line of site constraints can be met. If nuclear electric propulsion is developed for

use in the lunar or Mars cargo vehicle, the orbiting transfer vehicle may be a convenient power source for surface operations. If power beaming can be demonstrated at a reasonable cost, long term development could provide attractive benefits.

Extravehicular Activity

Requirements

Extravehicular activities will be a significant part of human space exploration and require a space suit that will enable unconstrained operations.

Due to the external environments, the suit must protect the occupant from vacuum, low-pressure atmosphere, extremes of temperature, clinging particles of dust, micrometeorites, and potential chemically reactive soils. The gravity levels vary from zero to three-eighths that of Earth. The suit must also be reliable, mobile, dextrous, comfortable, easily maintainable and compatible with all transportation systems.



Options

A number of technical issues arise from these requirements. Suit mass is constrained by the need for mobility and the level of gravity. Components for the rejection of waste heat use radically different mechanisms for operation in a vacuum versus low atmospheric pressure. The need for dexterity places constraints on suit pressure and indirectly on the breathing mixture. This in turn dictates the pressure and breathing mixture in the space habitats, if prebreathing is to be eliminated or minimized. Open loop life support yields simple engineering designs with lower suit masses than closed loop at the expense of increasing the amount of consumables. Open loop cryogenic life support concepts show great promise in reducing suit complexity and mass. The choice between hard and soft suits involves mass, mobility and maintenance issues. The clinging lunar dust and reactive soil of Mars present maintenance issues as well as potential threats from tracking such contaminants into the space habitats.

Baseline

The baseline concept is to have a single suit for use in space, on the Moon and on Mars. This drives many technologies. For example, a very low weight approach is needed for Mars. Also, present multilayer suit insulation loses most of its effectiveness in the Martian atmosphere; therefore a new insulation or a suitable overgarment for the present insulation, is needed. Open loop cryogenic support systems have clear advantages in reducing suit complexity and mass and are baselined over closed loop life support concepts. The only consumable in the open loop design is liquid oxygen, which provides both breathing gas and cooling. The consumption rate for liquid oxygen is governed by heat rejection. This design works equally well in surrounding vacuum and in low atmospheric pressure, markedly reducing the mass of the

carbon dioxide absorbing unit while eliminating the mass associated with a separate heat rejection system. For mobility at lowest mass, soft suits are baselined. A low pressure suit (less than 5 psi) is baselined for manual dexterity. (Apollo suit pressure was 3.75 psi.) To fulfill the suit-up-and-go requirement, prebreathing is eliminated by specifying low pressure in the space habitats.

Development Programs

Current space suit design is not adequate for the Space Exploration Initiative; however, the inadequacy stems from the suit design and not from the level of technology. The technologies required for the baselined space suit are mature but require additional development. Glove technology requires the greatest emphasis.

Life Support

Requirements

The partially closed environmental control and life support system would be based upon the following design considerations:

Air revitalization is required to provide a safe and habitable environment (atmosphere) for the crew. Specific requirements include carbon dioxide removal and reduction, oxygen generation, and trace contaminant and particulate control.

Water recovery is critical in order to keep life support logistical resupply within reasonable limits. This function represents the greatest technical challenge in the area of physiochemical life support. Waste water streams onboard spacecraft will arise from a variety of sources, including spacecraft condensate, urine, hygiene water (from showers, laundry) and possibly as a byproduct of carbon dioxide reduction. The water recovery system must be capable of scrubbing organic and inorganic substances from the

water stream in order to provide both potable water and lower quality hygiene water.

Waste management requires the processing of a number of varied waste sources, the most notable being solid human wastes and packaging materials.

Most spacecraft have utilized open loop life supports systems, where all consumables are supplied from Earth and waste products are either stored or vented to the space environment. Extended missions away from low Earth orbit would require a high degree of life support system closure. The incorporation of closed life support systems greatly reduce the initial mass in low Earth orbit for extended missions.

The economy of loop closure varies as a result of the amount of the effluent in a given loop. For instance, near-total closure of the water loop is required in that approximately 95% of the total waste mass is comprised of water from various sources. Recovery of oxygen from carbon dioxide results in substantial mass savings. The relative economy of recycling solid human wastes is dependent on crew size and stay times, since the recyclable waste per day is relatively small.

Options

The molecular sieve approach is the favored system from a number of candidates. The area in critical need of technology development involves carbon dioxide reduction. This technology has not been brought to a significant degree of maturity in the past in that the open loop systems utilized in both the U.S. and Soviet spacecraft did not require carbon dioxide regeneration. Competing systems typically employ either a Bosch reactor or a Sabatier reactor which vary in the chemical reaction processes. Another evolving technology which offers considerable promise is the direct

electrolysis of carbon dioxide by means of a ceramic electrode.

Trace contaminant control will be a crucial function. The presence of even low-level contaminants may result in significant health or performance effects. The existing technology for trace contaminant control utilizes absorbent beds in connection with a catalytic oxidizer. An ancillary function which is critical to the overall health of any habitable environment is the system for monitoring atmospheric contamination.

Several competing technologies for closing the water loop are available, including a number of distillation systems such as thermoelectric integrated membrane evaporation and vapor compression. These would be utilized in conjunction with one of the filtration technologies. The presence of bioregenerative systems (plant growth) in the water loop could improve the design of water recovery systems.

The technology utilized for waste management is largely driven by the extent of closure of the food cycle. A closed food loop implies recycling both human and plant wastes. The relative degree of closure of this loop is an important factor in the design of a waste management subsystem. Where the effluent of a small plant growth system (such as the salad machine) might be readily accommodated, a large bioregenerative component in a closed environment life support system would probably require a separate waste processing facility due to the different chemical processes needed for the specific waste streams.

The break-even point for a large scale plant growth system is dependent upon crew size, stay times, availability of plentiful power supplies and maturity of related technologies. The key research areas involved include plant growth techniques, food production, waste processing and contaminant removal and system integration/control. Full scale hybrid life support systems (physiochemical

and bioregenerative) are the most mature application of this activity. However, limited application of these techniques can yield significant benefits as well. For example, salad machines could provide fresh vegetables, partial air revitalization and partial water purification, and would provide significant psychological and physiological benefits to the crew members. A probable application for this capability would be on the Mars transfer vehicle.

Baseline

The requirements for life support systems on lunar transfer vehicles, lunar and Mars landers, or planetary rovers could be met by using existing technologies. This includes using open loop life support systems with a molecular sieve for carbon dioxide removal, absorbent beds in connection with a catalytic oxidizer for trace contaminant control and distillation systems for closing the water loop.

A partially closed environmental control and life support system has been baselined for permanent Moon and Mars habitats. The Mars transfer vehicle will be partially closed with recycled air and water.

Development Programs

The water recovery subsystem represents the greatest technical development challenge. The development of these subsystems as an integral component of a closed ecology must be undertaken for systems which are based on physiochemical subsystems or those with a bioregenerative component. Ground-based testing can be used to do integrated testing of subsystem hardware, with flight validation of the components.

Increasing the reliability and efficiency of air revitalization subsystems will play a critical role for exploration missions requiring closure of the air loop, both in the Mars transfer vehicle and in surface habitats.

Development of waste management technologies is closely linked to

closure of the food loop, and while implementation of waste recycling is not envisioned until a substantial lunar infrastructure is present, this technology is at a very low level of maturity. Programs focused on both small scale (salad machine) and large scale applications (biosphere) should be supported due to the long lead times anticipated for development of these technologies.

Planetary Surface Systems

Requirements

Habitats are required to support crews on the surface of the Moon and Mars, from six crew members with short stay times, up to 18 crew members for multi-year periods. The practical size of habitats and the requirement to transport them will dictate habitat design.

Short term space missions can be accomplished with small crew volumes; however, long term operations such as described in Architecture III would require 30 to 100 m³ per inhabitant. Accordingly, overall habitat size requirements range from 200 to 1,000 m³.

The habitat should maintain the crew in a mission-dependent level of comfort. The habitat system consists of a primary structure, life support system, internal structure and equipment and an airlock. The task of the primary structure is to maintain air pressure. The life support system manages and controls the air chemistry, temperature, food-water supply and waste removal. The comfort enhancing requirements are performed by a host of additional equipment. These include internal walls, floors, kitchen and hygiene equipment. The main requirement for the airlock is to limit air loss and dust entry.

The habitat mass (both direct and logistic needs) is one of the primary considerations on the mission launch requirements. Therefore, habitats must be designed to minimize both

their initial mass as well as the additional mass and power needed to operate them. Habitats must be designed to minimize the extravehicular activity effort required for construction, operation and maintenance.

Options

Habitats could be constructed using either rigid pressure vessels or inflatable structures. Radiation protection could be provided by either integral storm shelters or regolith. Physically separating the outside world from the controlled habitat environment is not a fundamental challenge, hence the technology issues largely revolve around the habitat mass and type of operations.

One of the simpler ways to limit the mass of a habitat is by optimizing its shape. Both lunar and Martian habitats must serve as pressure vessels, leading the designer to structurally efficient shapes such as cylinders, spheres, ellipsoids, or combinations thereof. Flat surfaces, common on most Earth buildings, impose mass penalties for these habitats and are used only for interfaces.

Two options are available to the habitat designer. At one extreme, a building block habitat is assembled by joining together a number of smaller, individually transportable modules. The other option is when the primary structure is preassembled, but then packed for transport. This approach includes inflatables. The choice between these two options impacts the mass and the installation requirement of the habitat.

The advantages to the building block approach are that much, if not all, of the internal structure and equipment can be installed and tested on Earth. Another advantage comes if one can exploit this modularity and develop common habitat modules. One of the problems with this concept is the need to do on-site linking of the modules, either involving automation, telerobotics or crew extravehicular

surface activity. Another drawback involves the inefficiencies of modularity and small unit size.

The construction approach allows more efficient use of transportation. This significantly reduces the launch requirements. This technique also involves a very different emplacement procedure. This offers the advantage of little to no exterior activity, but requires on-site interior assembly.

In small, short stay habitats, the exit door might be (as it was in the Apollo lunar module) a simple pressure hatch. However, for most missions, the habitat should use an airlock in order to limit the amount of air lost for each entry and exit. Its size must be selected, trading off mass and volume against the number of people. There are other functions the door must serve. For instance, an airlock could be required to serve as a dust cleanup room for crew members. It could also serve as the interfacing node between habitat modules. In this case flexible inflatable airlocks offer installation advantages to a design that otherwise uses rigid elements.

The life support system is another major factor that determines the habitat mass and operating cost. The primary issue involves the degree of closure adopted; complete closure occurs when the habitat's air, water, and food are recycled and used multiple times. Based on previous spaceflight experience, complete closure is an attractive option. Unfortunately, the recycling of these materials is not insignificant. The mass of the equipment needed to perform the recycling must be traded off against the supplies needed for an open loop operation.

Baseline

Rigid, single element, pre-outfitted habitats are baselined for early Moon and Mars missions. However, since inflatable habitats can provide signifi-

cant mass savings, they are an option for habitat expansion.

For habitats in which multiple rigid modules are required, the modules are connected by flexible nodes. These nodes may also serve as airlocks and installation interfaces. In order to simplify transportation and installation issues, inflatable habitat airlocks are baselined for technology development.

Development Programs

Habitat technologies are mature; therefore, a specific technology program is not required. However, as programs mature, some development may be required.

Robots, Rovers, Mining and Manufacturing

Requirements

Precursor missions are used as the most cost effective and efficient approach to perform reconnaissance and demonstrate equipment and processes. As such, the program emphasis should be on quick, cost effective precursors. All surface systems, subsystems, and components (mining, construction, life support, bearing, seals, etc.) could be developed in terrestrial simulators and selectively tested in precursors as either scale models or subsystems.

Resource characterization would concentrate on no more than three near-side equatorial regions to quantify mineralogy and chemistry. Lunar surface site selection would also characterize surface topography (stereo visual imaging) and regolith structure (electromagnetic sounder) and electromagnetic noise background. Key variables are the number of precursors and site selection approach. Surface requirements for resource development include a robotic rover to locate resource deposits, perform chemical and evolved gas analyses and establish physical properties at selected sites.

A precursor engineering experiment station to perform proof of principle tests of these operations would be required to support lunar mining and construction activities. These mission requirements focus on the means to excavate, move and process lunar regolith for shielding and in situ materials utilization (propellants, structures, solar cells).

Unpressurized rovers are required to transport both materials and crews 25 km, and for pressurized crew rovers with 2 to 3 day duration and 100 km radius of operation.

Robotic Orbiter and Surface Precursors

- **Advanced imaging detectors, including improved charge-coupled device arrays and data handling subsystems**
- **Compact multispectral imaging radar and Lidar for surface and subsurface characteristics**
- **Compact chemical analysis instrumentation, including gamma and x-ray spectrometers and imaging spectrometers**
- **Telerobotics and telepresence, including control architectures and supervised telerobotics, data handling, storage and virtual reality techniques**
- **Small spacecraft with gross masses less than 500 kg, including orbital "prospectors" and surface penetrators**
- **Autonomous systems to enhance Mars operation**

Mars precursors collect information to evaluate site attributes and safety, chemical and physical properties, and possible toxic properties of the surface material. This requires visible imaging, with detailed local site maps having 1 m resolution, and global maps with 10 to 100 m resolution. The site reconnaissance orbiter obtains the required data to cover selected sites. Once sites are selected, surface precursors are required to validate engineering properties and perform in situ chemical measurements of toxicity.

A robotic sample return mission has been suggested as a precursor to human missions to Mars. Although there are some concerns regarding the possible toxicity to humans of the Martian soil, chemical tests of such effects can most likely be performed remotely by carefully designed experiments carried aboard a robotic rover. The biology experiments on the Viking landers failed to reveal the presence of organisms within the Martian soil. A convincing case has yet to be made for contamination of the Earth by hypothetical Martian

organisms. Until further data becomes available, it would be prudent to be conservative in protecting for contamination. Care should be taken, when practical, to preclude contamination of the Martian environment by Earth organisms. Moreover, the long duration of a round trip to Mars results in sufficient quarantine for the crew; infectious properties of Martian samples should be evident within such time spans. If humans are to explore Mars, the scientific case for a robotic Martian sample return as a required precursor becomes less tenable. For these reasons, there are no compelling requirements for a precursor robotic sample return mission.

Mars exploration will require a pressurized crew rover with a 100 km travel radius, and a teleoperated robotic rover with 100 km radius. Robotic rovers must be capable of conducting in situ chemical and physical analyses (x-ray fluorescence, gas chromatography/mass spectrometry, electromagnetic sounding) and collecting samples for return to the base camp. Rovers may be designed to take advantage of in situ resource uti-

lization to extend their range. Robotic explorers are needed to extend coverage of the Moon and Mars surfaces.

Telepresence is a method of permitting complete human control of robotic explorers on planetary surfaces. The concept is to simulate reality for the human operators such that they believe they are physically present on the surface of the Moon or Mars. The telepresence mode involves very high-definition stereo television, mobility and agile locomotion. The techniques of telepresence and teleoperations require user-friendly interfaces (operator exoskeleton for robot control) and high data rate communications (500 Mbps-class). Visual sense should approach human vision (resolution in the center of 30 seconds of arc, equivalent to 10,000-line television); moreover, enhancing spectral coverage (e.g., infrared bands) should also be covered by the vision system. The robots on the planetary surface must be

Lunar Roving Vehicle Near Stone Mountain, Apollo XVI

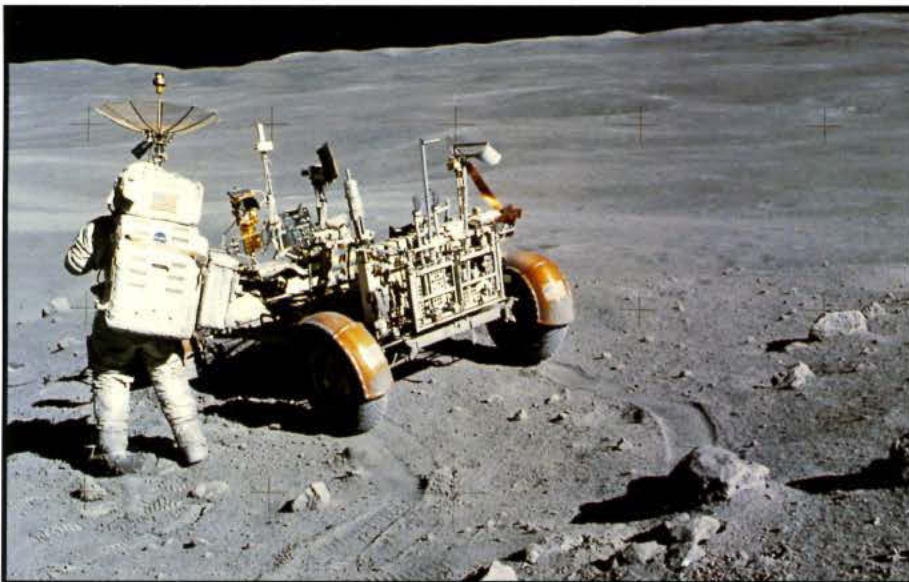

Rover Systems

- **Efficient regenerative fuel cells (1 kW-hr/kg) with compact insulated cryogenic storage tanks**
- **Compact, specialized life support systems for short (2 to 3 day traverses) duration, and portable radiation protection features**
- **Crew supported telerobotic surface driving systems and telerobotic extension systems with dexterous robotic manipulators**
- **Compact deployable photovoltaic arrays (200 W/kg or better)**

dependable, rugged and possess travel ranges exceeding 200 km.

The initial in situ resource demonstrations at Mars would focus on the production of water and methane using hydrogen brought from Earth. Other approaches include heating the Mars regolith to extract water of hydration, and by subsurface drilling to extract water from either permafrost or water ice deposits.

Movement of Mars regolith for radiation shielding and construction of habitats would commence on long duration missions (e.g., 600 day surface stays). Lunar experience would be helpful in developing these capabilities and lunar equipment may be directly scalable.

Options

Teleoperation and crew-tended operation are usually more favored than fully automated systems. This suggests that the crew should always be within short communication times of robotic systems. Major effort would be required in determining the degree of automation necessary or preferable for each system.

Development of telepresent technologies can follow the general technology trends of the robotics community. In particular, very high-definition systems technologies should be incorporated into designs as soon as possible. Rover-based or walker-based technologies for robot locomotion should be developed in parallel and a design decision deferred until the best system can be identified.

Distributed multiple small orbiting systems (e.g., prospectors) would be used versus large orbital platforms (Observer or Viking class) for orbital tasks. Smaller systems are generally less capable than the larger systems, but they may offer quick and cost effective options to gather specific data. Advances made in miniaturization indicate that dedicated systems could be very capable and they offer a preferred solution.

Remote sensing systems are being developed to support Mission to Planet Earth; therefore, integration into systems for the Space Exploration Initiative offers great potential. The robotic systems are potentially significant extensions in both size (smaller, lighter) and operations from existing terrestrial systems; however, a significant technical and experience base exists from which to begin. These systems are judged to be of medium risk. Software development and subsystem integration appear to be the most difficult element in the robotic system applications, followed by machine design for both the lunar and Martian environments.

The highest development and operational risk areas are the planetary surface systems. Little experience beyond conceptual designs exist for systems which must excavate and process materials on the Moon and Mars. Extensive development and testing in simulated and actual environments would be required to gain any confidence in reliable operation, especially for automated or telecontrolled modes.

Baseline

Small distributed teleoperated systems should be selected over large highly automated systems for both surface and rover systems. The initial telerobots would be under total human control (except for automating simple tasks, such as transport between stations). They should carry stereo high-definition imaging and human-like manipulators. Continuous, high data rate communications are required. Transportation across the planetary surface must be in a vehicle able to successfully negotiate terrain types specified from precursor mission data.

Experimental and pilot systems for in situ resource utilization would have central processing sites with mobile regolith collection, although experiments in mobile processing will also be conducted. Central processing

in the early stages also offers the opportunity to utilize waste heat at the base for some process heat requirements.

Development Programs

Orbital and surface precursors will benefit from the technology and sensors developed for Mission to Planet Earth. These programs should be reviewed and their development prioritized to architectural needs and related schedules.

Spacecraft

Requirements

Lunar and Mars transfer vehicles must be designed for low launch mass/volume and minimal on-orbit assembly, but maximize crew safety. Automated rendezvous and docking of spacecraft will reduce on-orbit assembly requirements for Mars missions. Cargo transfer vehicles must, by necessity, have the ability to join three or more vehicle segments in low Earth orbit. The transfer vehicles must provide for crew comfort, communications, control and science needs; however, the balance will vary with mission duration.

Regardless of the mission duration, radiation protection from solar flare events and galactic cosmic rays are a critical issue for crewed missions. Methods for reducing the mass of radiation shielding and refining the prediction of solar flare events would directly enhance crew safety and decrease cost.

Options

Spacecraft designs are limited by materials properties and fabrication methods; advances in these areas will enable improved spacecraft concepts. Current spacecraft designs are based on using aluminum for temperatures below 450°K and titanium for up to 811°K. Spacecraft will rely on light alloys, metals, ceramic and polymer matrix composites. With these materials, new fabrication processes such as

superplastic diffusion bonding will be required. These techniques allow for greater weight savings through reduced part counts.

There are two active radiation shielding concepts: magnetic and electrostatic. Neither is capable of eliminating space radiation but could reduce the dose from solar flare events. Reductions in the radiation burden would reduce the health risk associated with long duration missions.

Solar flare events can last several days. Passive shielding can provide protection for limited volumes; the mass required to shield the entire transfer vehicle is prohibitive. Water has excellent stopping power. The shield can also act as a reservoir for the water supply.

Automated landing, rendezvous and docking can be accomplished

Lunar Excursion Vehicle

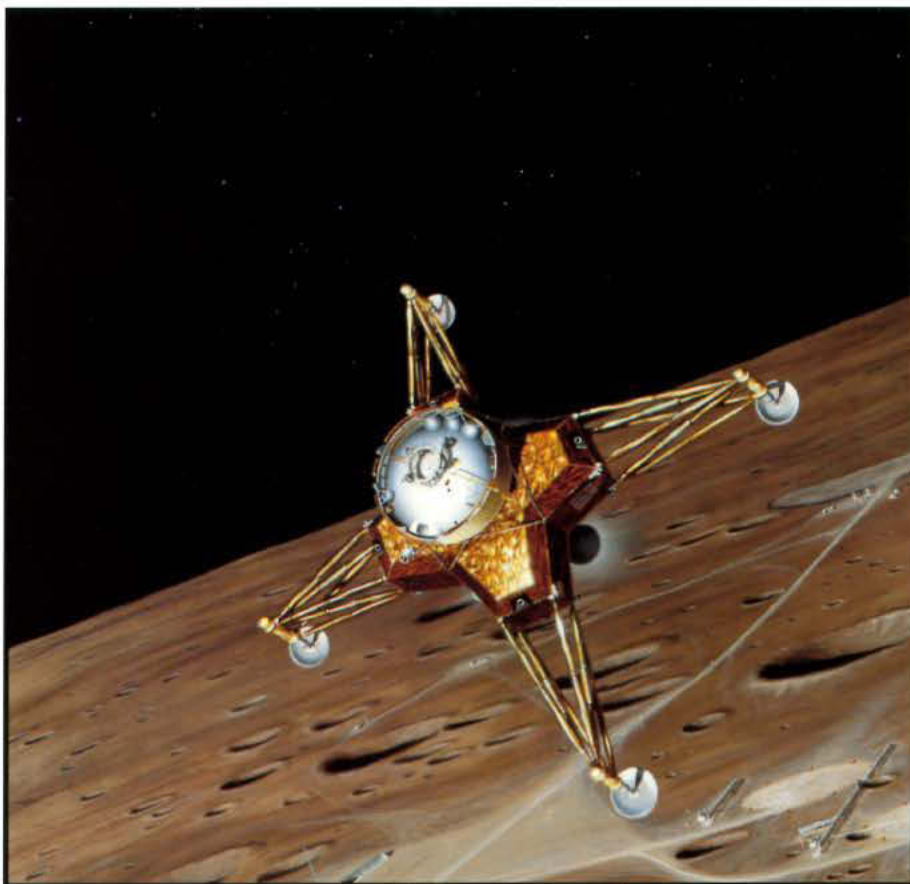

with laser rangefinder or compact solid state radars with onboard processing and control.

Baseline

Spacecraft structures will use standard materials (aluminum and titanium) and fabrication techniques; however, improved fabrication methods and advanced materials will be substituted where appropriate.

Hybrid radio and optical systems will provide the long range and close accuracies needed for docking large masses.

Water can be used as passive shielding for solar flare events.

Development Programs

The development of new material is required for advanced spacecraft concepts. Candidate materials for reduced part counts and weight include: light alloys (aluminum-lithium, intermetallics, metal matrix composites and polymer matrix composites), advanced thermal protection materials (ceramic matrix composites, carbon-carbon and spray-on foams), light alloys using superplastic forming and diffusion bonding, metal matrix composites using hot pressing and joining, polymer composites using tape placement, woven ply lay-up, pulltrusion resin injection and thermoforming.

The Space Exploration Initiative will benefit greatly from the technology being developed in such programs as the National Aerospace Plane and the Strategic Defense Initiative. The appropriate utilization of these technologies is recommended.

Communications, Control and Navigation

Requirements

Effective communications and information management systems for mission control, science data return and radiometric support for navigation are essential.

For all architectures, lunar operations are planned for the near side of the Moon. Aggregate downlink data rate from all elements could grow to 350 Mbps, with a modest application of data compression. The uplink data requirements could grow to an aggregate of approximately 25 Mbps.

Mars operations will require communications ranges up to 1,000 times more distant from Earth than the Moon, which results in a spatial signal loss that is one million times greater. Communication networks in the Martian environment (either in Mars orbit or on the surface), will be required to operate autonomously from any facility on Earth for realtime command and control decisions. With the application of new data compression techniques, a downlink data rate of 20 Mbps can be achieved. Uplink data rates will be approximately 10 Mbps.

Data compression is required to reduce transmission rates, as well as antenna size, weight and transmit power. Simply put, data compression is the process of sending information down a narrower corridor. For example, 10 megabits of data can be downlinked via a communications channel that has a 1 Mbps data rate in 10 seconds. At a compression ratio of 2:1, the same amount of data could be downlinked via a 0.5 Mbps channel in the same amount of time. Further advancement of data compression techniques would reduce transmission costs, increase relay satellite capacity and provide a practical means of delivering high data rate imagery.

Options

Communication requirements for the Initiative could be satisfied with a wide range of existing technologies.

Frequencies for deep space communications include the X-band capability at 8.4 GHz, Ka-band at 32 GHz and optical band.

Deep space missions are supported today using X-band 8.4 GHz, so

there is little to no risk involved if X-band radio frequencies could be used. However, due to the high data rates anticipated, X-band is not a practical choice.

Ka-band communications systems are more sensitive to weather effects and require more accurate antenna pointing. Ka-band technologies (primarily power amplifiers and low noise receivers) will require a development program to achieve a communications system with the reliability to support human missions.

There are a number of key developmental challenges that must be met in order to realize the potential of optical communications. The challenges are in the area of detectors and detector arrays; long-life, high-power laser sources; accurate telescope pointing; spacecraft stabilization systems; and acquisition and tracking technologies. Optical communications systems are also severely restricted by environmental conditions.

Antenna systems will have more demanding pointing requirements as frequencies increase. Current antenna systems that support extremely high frequencies are either parabolic dishes or phased array antennas. Phased array antennas replace the traditional dish antennas with a large number of antenna elements. Pointing is accomplished electronically via adjustment of phase shifters associated with each element. Depending on the mission application, a hybrid of both systems could provide for autonomous acquisition and tracking.

Multi-beam antennas are similar to phased array antennas, but with antenna elements located at the feed of a traditional reflector antenna. The advantage of using multi-beam antennas is that they provide greater operational flexibility. For example, the lunar base could communicate directly to Earth with one beam, to an orbiting spacecraft with a second beam and to a rover on the lunar surface simultaneously. Developing multi-beam antennas would involve little risk and has consid-

erable potential application for commercial use.

One technology that would support many antenna applications (multi-beam and phased array, primarily), is monolithic microwave integrated circuits. These circuits offer the potential for improved performance, higher reliability, radiation hardening and size and weight reductions. Significant benefits to the telecommunications industry will be realized by maturing this technology, presently a high risk endeavor.

Expert systems and neural networks provide the ability to conduct autonomous operations, a necessity for Mars-based real time command and control. Knowledge-based expert systems that require human supervision are currently supporting space system operations; however, the addition of neural networks will greatly enhance Mars autonomous operations. Substantial risk is involved in developing hybrid systems combining neural networks and expert systems for adaptive control.

Expert systems are currently used for medical diagnostics. Humans update the expert system's database, input symptoms of the problem and suggest potential solutions to be evaluated by the expert system. Some risk is involved with developing expert systems of this type since their use has not had widespread operational validation.

Earth-based navigation, onboard navigation, and Moon/Mars-based navigation systems are all required for supporting interplanetary missions.

Earth-based navigation is currently used for planetary exploration. Radiometric data from tracking stations, optical data and Doppler data from spacecraft-to-spacecraft are processed on Earth to obtain spacecraft orientation and position. However, this method cannot adequately support Space Exploration Initiative missions when critical real time navigation is required.

Spacecraft onboard systems satisfy the need for real time navigation during critical operations (e.g., orbit insertion, landing, surface exploration, ascent, rendezvous and docking).

A Mars-based navigation network would be used for precise, real time position determination. This system would work with a Mars-centered inertial coordinate system or a surface-fixed coordinate system. The origin could be located at the primary landing site, thus eliminating sources of error associated with an Earth-based system.

Baseline

Because of the communications time delay between the Earth and Mars, hybrid artificial intelligence

or neural network systems may be used for making real time command and control decisions, performing acquisition and tracking, optimizing resource utilization, conducting teleoperations, controlling extravehicular activity, and monitoring consumables and system health and performance.

X-band will be used for the Earth-to-space uplink, Ka-band for all inter-space and downlinks and optical communications for later space-to-space links.

Lunar missions can be supported using antennas smaller than 34 m, but 34 m antennas are needed for Earth-Mars communications. These antennas would need to have a multi-beam capability and incorporate monolithic

Madrid Deep Space Communications Complex



microwave integrated circuits as soon as that technology becomes available.

Earth-based navigation will be the primary means of providing position information in the lunar environment.

Radiometric navigation alone does not provide the timeliness or accuracy required for critical operations in the Martian environment. Improved inertial measurement units, transponders, navigation computers and ranging devices, spacecraft onboard processing and radiometrics will provide the accuracies required to support Mars missions.

Development Programs

The baseline technologies for communications are either existing or are in advanced stages of development (independent of the Space Exploration Initiative); therefore, the technology development description also provides an estimated maturity level.

Ka-band communications for deep space missions will require the development of high efficiency traveling wave tube amplifier transmitters with power levels of 10 to 150 W and high efficiency solid state transmitters with power levels of 1 to 15 W. Traveling wave tube technology is currently at the breadboard stage. Solid state technology is currently at the concept phase.

The development of laser transmitters and low noise detectors are required to make possible optical communications for deep space applications. This technology is at the breadboard phase.

A range of antenna systems must be engineered, including electronically steered multi-beam antennas, retractable antennas (Ka-band), high power microwave monolithic integrated circuitry and direct-radiating monolithic microwave integrated circuit phased arrays.

Data compression will be necessary to reduce the data storage requirements and the transmission demands on the communications system.

Compression schemes are being aggressively pursued by a number of telecommunications companies. An effort is required to space-qualify hardware decoders and other associated data compression equipment.

Navigation systems will rely on the development of transponders with 10 m accuracies and onboard sensors including inertial measurement units, altimeters and computers. These technologies are in the proof-of-concept stage.

Information management systems will rely on the development of expert systems, neural networks and data compression techniques. This technology is in the concept/application formulation phase.

Summary

As a result of the review of the seven functional areas and Life Sciences, 14 areas of technology emphasis have been identified that require effort essential for enhancing the Space Exploration Initiative. These include:

- 1) Heavy lift launch with a minimum capability of 150 metric tons with designed growth to 250 metric tons
- 2) Nuclear thermal propulsion
- 3) Nuclear electric surface power to megawatt levels
- 4) Extravehicular activity suit
- 5) Cryogenic transfer and long-term storage
- 6) Automated rendezvous and docking of large masses
- 7) Zero gravity countermeasures
- 8) Radiation effects and shielding
- 9) Telerobotics

- 10) Closed loop life support systems
- 11) Human factors for long duration space missions
- 12) Light weight structural materials and fabrication
- 13) Nuclear electric propulsion for follow-on cargo missions
- 14) In situ resource evaluation and processing

At first glance, the implementation of the architectural approaches outlined appears daunting. It is indeed complex, but the Synthesis Group finds that America's ability to return to the Moon and begin the exploration of Mars depends on two fundamental technologies: the restoration of a heavy lift launch capability and the redevelopment of a nuclear propulsion capability.

This nation had both of these capabilities in the early 1970s. In addition to these two areas, the 12 other technologies listed, if successfully developed, offer the potential for vastly enhancing the exploration of the Moon and Mars. This listing identifies the critical technologies needed to support the four architectures outlined by the Synthesis Group's report.

¹ This recommendation is consistent with and expands upon those made by the Advisory Committee of the U.S. Space Program.

² NASA, Johnson Space Center, Code XE memorandum dated January 11, 1991, "Preliminary Heavy Lift Launch Vehicle (HLLV) Requirements for the Space Exploration Initiative," Norman H. Chaffee.

The Space Exploration Initiative represents a major management challenge as well as a significant technological challenge to this country. The Space Exploration Initiative is greater in scope and more demanding than the Apollo program of the 1960s and 1970s. It will require a method of management that will allow crisp and timely decision making.

Vice President Quayle asked that we investigate options to accomplish our exploration goals faster, cheaper, safer and better. It is usually assumed that new technology is required to achieve such goals. Experience has shown that management and acquisition approaches can have as great an impact on program success as technological achievements. The management challenge is to organize the Initiative to a new standard of excellence, employing innovative techniques for ensuring efficiency and effectiveness. The Space Exploration Initiative will involve a number of government departments in addition to NASA. In support of efficient management, the acquisition procedures employed by the Initiative should be streamlined.

The Initiative requires the very best from America to provide the systems needed to take humans to the Moon and Mars and safely return them to Earth.

The capability exists within the combined resources of the government, industry and the academic community to accomplish the Space

Exploration Initiative. The concept of multi-agency participation is supported by the Presidential Space Policy Directive issued by the National Space Council in a memorandum dated February 21, 1990:

“The program will require the efforts of several agencies. NASA will be the principal implementing agency. The Department of Defense and the Department of Energy will also have major roles in the conduct of technology development and concept definition. The National Space Council will coordinate the development of an implementation strategy for the [Space] Exploration Initiative by the three agencies. To facilitate coordination, the Department of Energy will be added as a formal member of the National Space Council.”

History provides some basis for what constitutes effective strategies in major aerospace and other high technology programs. The Synthesis Group reviewed numerous reports of successful and unsuccessful programs, and studied various acquisition improvements and key factors that helped reduce the cost of the most successful aerospace programs. Costing models often reflect these factors by employing cost growth algorithms based upon inefficient management practices and decreasing productivity. It is therefore essential that any proposed management structures address the elimination of such inefficient practices. The proposed management structure is based on these studies and the goals outlined by the Vice President.

National Program Office

Organization

As the Space Exploration Initiative is national in scope and involves significant resources of not just one but many Government agencies, a

“It is mankind's manifest destiny to bring our humanity into space, to colonize this galaxy. And as a nation, we have the power to determine whether America will lead or will follow. I say that America must lead.”

Ronald Reagan

National Program Office should be established by Executive Order.

The program office would be staffed with NASA, Department of Defense and Department of Energy personnel working directly for the National Program Office. Other government departments and agencies would be added as the Initiative matures.

The National Program Office will become the instrument for NASA's Associate Administrator for Exploration to exercise responsibilities with respect to the Space Exploration Initiative program. In addition to his responsibilities for both robotic and manned exploration of the Moon and Mars and the humans-in-space portion of life sciences, the Associate Administrator would be appointed the National Program Director for the Space Exploration Initiative. As the Initiative increases in scope, it may require this position be assigned responsibilities commensurate with a Deputy Administrator.

Interagency Interfaces

The National Program Director will be given authority over all projects and development areas necessary for executing the Space Exploration Initiative. It is necessary that the advanced technologies required by the Space Exploration Initiative be within the purview of the National Program Director. Basic research and technology development will continue to be performed by lead agencies.

Because of the Space Exploration Initiative's broad scope and multi-agency involvement, effective management is needed. The Advisory Committee on the Future of the U.S. Space Program recommended the formation of an Executive Committee of the National Space Council. The proposed committee, with the addition of the Secretary of Energy, could provide a needed commitment to technology development and ensure intra-agency development priority and budgeting. Technology needs

would be based upon a National Program Office technology plan, addressing Space Exploration Initiative architectures and schedules. Also, as cost is of higher priority than schedule, when the schedule changes, the Executive Committee will ensure proper phasing among the various agencies' projects. The Executive Committee members also provide policy advice and consent for their respective agencies in support of the Associate Administrator of the Space Exploration Initiative.

NASA Interfaces

Since the Space Exploration Initiative will become the centerpiece of the national space program, it is appropriate that the Associate Administrator for Exploration be given greater authority and responsibility than currently exist within the Associate Administrator structure. This official will utilize the expertise of a number of NASA centers, as appropriate, as well as other government laboratories and the academic community. As the activities of the Space Exploration Initiative increase in scope, in keeping with the current organizational concept, it would probably become necessary to realign centers under the Associate Administrator for Exploration. However, with widely varying activities at the centers in support of more than one Associate Administrator, a management structure with the field centers reporting directly to the Administrator might be more efficient and better suited to the decade of the 90s.

Responsibilities and Technical Functions

Program management must address such functions as systems architecture planning and requirements control. The responsibilities at the headquarters level are to identify key program requirements and review the implementation of programs, but not execute the activities. Such detailed

design and development is best accomplished at the field levels.

The National Program Office should develop a technology plan to identify research priorities. This plan would identify key technologies to be initiated. The technology plan would form a basis upon which interagency commitment for technology development would be established. In addition, the plan would establish a five-year technology vision.

Consolidating federal resources, where appropriate, and guarding against the effects of institutional aging and development of bureaucratic culture, will be key in deriving the plan.

A formal requirements validation process, controlled by the National Program Office, is key to exercising discipline during program planning and execution. The requirements control and validation process will enable the National Program Office to exercise the discipline of configuration management during technology development.

Staff Functions

Staff functions, such as program control, procurement and legal, will provide the capability to prepare consolidated budgets and provide advice on acquisition streamlining and procurement management. Both procurement and legal functions are usually not dedicated to an organization. The autonomous nature of the procurement system, coupled with the commercial and international opportunities, are persuasive arguments for including these disciplines as dedicated resources.

Other staff functions can be provided to support the Space Exploration Initiative through a normal, matrix organizational relationship. The organization itself should evolve to change the needed matrix disciplines to dedicated staff functions.

Field Level Support

Both from a program management and cost efficiency standpoint, it is essential that streamlined management mechanisms are in place for the Space Exploration Initiative. Field support is key to the success of the Space Exploration Initiative.

While the National Program Office headquarters staff would be involved in requirements definition and program review and coordination, the field level organizations are the focal points for specific project design and development. As a part of the National Program Office, system engineering and integration would be done in the field, as the field centers have the depth and technical expertise not readily available at headquarters. Streamlined channels of communication, including project authorization, requirements, schedules, reporting and funding, are critical. The Space Exploration Initiative field center project officers would report directly to the respective program manager at the National Program Office. Work at the field level would be based upon a contract-like agreement whereby the institutional line of command would be responsible for meeting the needs of the various projects housed in its facilities in an efficient manner.

Procurement and Acquisition Issues

Numerous studies of the federal procurement process, such as the President's Blue Ribbon Commission on Defense Management Report, indicate a need for improvement which will lead to cost and time efficiencies and still maintain the integrity of the procurement system. As was noted by the Advisory Committee on the Future of the U.S. Space Program, since 1965 the procurement process has been impacted by at least 125 public laws, Executive Orders, Office of Management and Budget circulars and Office of Federal Procurement Policy letters.

These provisions generally require implementation in the Federal Acquisition Regulation and agency supplements.

Review of federal and NASA procurement regulations reveals that there are over 200 clauses and provisions applicable to a large dollar value cost-type contract. The impact of these regulations and policies is felt not only at the prime contract level, but flows down to even the lowest tier subcontract. Private industry is often discouraged from doing business with the federal government because of the complex and time-consuming procurement system and associated costs.

In undertaking the Space Exploration Initiative, NASA should be authorized to tailor the existing procurement system and devise new procedures to fit the needs of this major new Initiative. Working with private industry and other nations is critical to the success of the Space Exploration Initiative, and it should not be stymied by an overly cumbersome procurement process.

There are opportunities presently within the authority of NASA to streamline some of its functions. For example, the expanded use of broad agency announcements for research and technology requirements can be implemented under current authority and will improve the efficiency of the acquisition process.

Streamlined procedures, centering on an autonomous procurement system for the Space Exploration Initiative under the authority of the Space Act, should be implemented. Such a system would entail the delegation by the NASA Administrator of Head Contracting Activity authority to the National Program Office. Currently, the major NASA field centers have been provided head contracting activity delegations with a \$25 million limitation of signature and approval authority. This limitation should not be imposed for the Space Exploration Initiative, but other checks and bal-

ances should be built into the system through a modified contract review procedure.

The Space Exploration Initiative, with the advice and assistance of appropriate NASA headquarters staff offices, will draft a comprehensive description of its procurement procedures under appropriate "Federal Acquisition Regulation" and "NASA FAR Supplement" provisions (except as otherwise permitted by the proposed pilot test program). This system would then be reviewed and certified by the NASA Headquarters Office of Procurement in a manner similar to the approval of a prime contractor's procurement system. Once the system is in place, the National Program Office should have the authority to manage its acquisition program.

The Assistant Administrator for Procurement for NASA Headquarters would retain the approval authority for deviations from the NASA Federal Acquisition Regulations Supplement. Deviations, if any, from the Federal Acquisition Regulations

Back to the Future

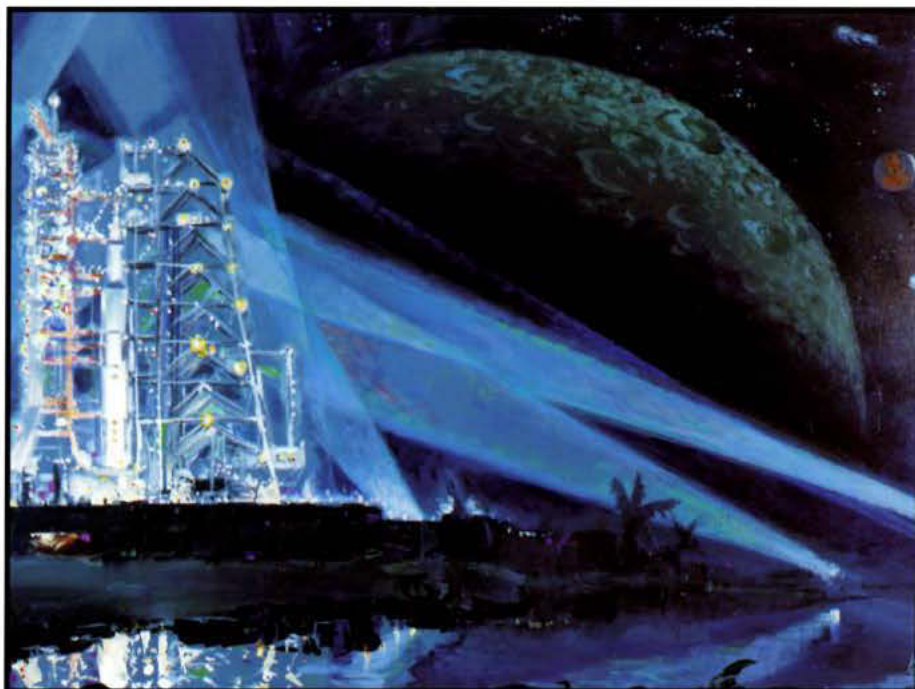

would be processed through that individual in a normal manner.

As an additional means to streamline and maximize procurement efficiency, Congressional authorization of a pilot test acquisition program should be granted for the Space Exploration Initiative similar to the approval granted to the Department of Defense for a limited number of its programs under Section 809 of Public Law 101-510. Under that procedure, the Department of Defense pilot programs are conducted in accordance with standard commercial industrial practices and allow the Department of Defense to waive specified procurement provisions. A similar pilot program for the Space Exploration Initiative would place greater reliance on existing and proven acquisition and management systems.

These procurement procedures would be applicable to the Space Exploration Initiative project offices at NASA field centers and other participating federal agencies' project offices, as well as the National Program Office.

International Opportunities

The opportunity for a number of international cooperative ventures will exist, and the complexity and sensitivity of this function will require professional staff support. Options for cooperative participation with other spacefaring nations are under consideration. Cooperation could well include flying life sciences experiments or medical equipment, and possibly flying U.S. crew members on the Soviet Mir Space Station to facilitate the early gathering of long duration flight data. Involving wider participation from agencies and nations interested in space, the program office can

establish plans for the development of common, international databases for planetary information to facilitate the future exchange of information obtained from precursor missions.

Commercial Opportunities

Commercial potential abounds within the framework of the Space Exploration Initiative. Launch services, communications satellites, robotics, production of materials in space for use in space and on the Earth, and electronics technology are a few. These activities may provide sources of long term Space Exploration Initiative revenue beyond the federal budget. Opportunities for private citizen and commercial sector investment should be examined along with opportunities for state and local investment.

Plans should be developed for the federal government to transition areas of potential commercialization into real commercial ventures. The Synthesis Group's architectures form the foundation to identify facilities, service activities and processes which can be commercialized.

Because of its broad scope of technology and operation, the Space Exploration Initiative presents myriad new opportunities for commercialization. These should be explored with industry during the early phases of the Initiative and be developed to their fullest potential. Joint government and industry conferences should be conducted at the earliest opportunity following the approval of Space Exploration Initiative funding. These conferences would provide an essential forum for identifying areas of commercial interest. Further program planning would then be able to integrate the commercial involvement. This might take the form of

government funding of technology and development in high risk areas prior to commercial exploitation, cost-sharing in some areas, or full commercial funding in others where the return on investment is readily apparent.

Implementation

With the multi-agency nature of the National Program Office, an Executive Order should be prepared and issued to cite the basic charter of the organization, the leadership role of NASA, and the cooperative relationship among various governmental departments and agencies. The Executive Order should clearly enumerate the staffing, budgeting, and reporting relationships and responsibilities of the affected agencies.

A Journey into Tomorrow



OPERATIONS AND FACILITIES

Operational Assumptions

- Operations capabilities and concepts evolve over the life of the program
- Mars operations are structured to benefit from the lessons learned from the Moon operations
- Advanced technology, as it becomes available, enhances the ability to perform various missions and tasks
- Multi-mission and multi-program operations require new management structures, emphasizing the coordination and mutual dependencies of program elements
- A radiation hazard program establishes the guidelines for long duration spaceflight
- Planetary quarantine requirements are established for forward and backward contamination issues
- Long term crew health issues, both physiological and psychological, will be resolved
- Guidelines for maintaining crew health and performance in space and planetary surface environments are established
- Mission support elements are in place and verified in operational tests prior to required use
- A formal site selection process is instituted for surface landing site selection
- In situ resource utilization on the planet surface is successfully demonstrated prior to being required for routine operations
- Abort capability is assured throughout all phases of the Space Exploration Initiative
- Closed loop life support requirements enroute and on planet surfaces are successfully demonstrated prior to being required for operations
- Necessary communication, navigation and data handling systems evolve

Elements common to all architectures are operations, communications, navigation and facilities. Specific operations might differ because of the varying requirements of an architecture or operational capability.

Operations

The operations activity addresses issues related to planning, training, launch and mission control of lunar and Martian missions. This includes mission support throughout all phases, as defined by the four architectures.

Philosophy

The operational philosophy is based upon ensuring simple management and technical interfaces. Operational control is placed at the location (closest to the required actions) having adequate information and situation awareness to make decisions. During a Mars mission, for example, with communication round trip delays of up to 40 minutes, many critical operational decisions will be made by the crew.

Reliability, redundancy, simplicity and modularity must be incorporated in the structure and design of systems. A thorough test and evaluation program, along with a proof of concept and validation phase, is also essential and should be implemented throughout the Space Exploration Initiative. Operations support must begin early in the development stage and operational considerations should be incorporated in the planning and design phases to reduce operational risks and costs over the program lifetime.

Operations Concepts

An operations concept has been developed for each architecture. The operation requirements common to all architectures are:

- Command and control assigned to the crew as appropriate

- On-orbit test and verification
- No single person surface operations
- Manual override of critical automated systems
- Graceful system degradation

The phases of implementation of each recommended architecture — Initial Operational Capability and Next Operational Capability — affect the overall operations activity. At each phase, operations are assessed by the mission commander, based on mission planning and available support.

Precursor missions provide many of the support elements. Precursors include missions for logistics, communications, meteorological experiments and other requirements for the support of piloted missions. Specific precursor missions will be used for initial landing site selection to ensure that activities can be planned.

All selected sites on a planetary surface must be certified for human safety. Permanent site selection is accomplished only after human exploration of the designated sites. Robotics and telerobotics perform commanded tasks and enhance human presence in space.

Launch Control

Launch control is responsible for all activities required to support the launch of all space vehicles. These activities include facilities support, transport of elements, processing, testing and checkout of vehicles and supporting elements.

Mission Control

Advances in technology and autonomy greatly enhance operations as well as improve their flexibility and efficiency. Mission control operation elements include:

- Command and control

- Systems trend monitoring and assistance to the crew
- Operations planning and science support
- Support of software, systems and equipment anomalies

Inflight Operations

The duration of the Mars missions requires an innovative approach to providing crew support. Both the crew and onboard systems must have the capability to monitor and control all safety-critical functions during normal and contingency operations without ground support. Inflight operations are:

- Maneuvering spacecraft
 - Flight control and guidance
 - Rendezvous and docking
- Proficiency training
- Maintenance
- Navigation
- System monitoring
- Life sciences
- Astronomy

Transfer Operations

Descent operations to the planet surface require precise landing navigation and descent control to a predetermined site. Ascent from the planet surface requires precise navigation, control, rendezvous and docking. Descent and ascent vehicle operations will be automated to the maximum degree possible with the crew having the ability to intervene manually.

Surface Operations

A structured crew organization is required to coordinate and accomplish planning, mission objectives and other duties. While mission planning

is accomplished on Earth, day-to-day activity planning is conducted by the crew on the planetary surface. It is anticipated that surface operations will take place in cycles that would not correspond to normal Earth operations. These plans are generated for short duration tasks of one to several days and include all work plans in support of the mission objectives.

The mission objectives provided from Earth are modified as necessary based on scheduled updates. The crew will have the flexibility and the autonomy necessary to conduct their own activities and scheduling. Routine operations and short term goals are based on the expedition milestones or mission objectives as modified by the mission commander. A cyclic pattern of established operations is also utilized for most activities, including periods for maintenance, housekeeping, rest and recreation.

An essential component of exploration is extravehicular activity. A minimum of two astronauts will be required for each activity for safety considerations and the base will always be occupied during these periods. Flexible scheduling and mission control are key to successful surface operations. The astronauts must have as much autonomy as possible to determine their own pace and style. Although crews will work within a general exploration plan, the actual traverses and surfaces activity will not be planned on rigid timelines. Flexible surface operations are essential if significant discoveries are to be made and the necessary follow-up investigations are to be carried out. Surface operations also include the support of site facilities and surface vehicles.

Maintenance

System design is kept as simple as possible to permit mission objectives to be completed in a safe and timely manner. Reliable designs and multiple levels of parallel redundant systems with low maintenance re-

Operational Priorities

- To ensure the safety and health of the crew
- To maintain integrity of the functional systems
- To accomplish the mission objectives

Operations Organization

- Training
- Readiness verification
- Launch and recovery support
- Command and control
- Mission planning, management and execution
- Integration and coordination of all mission objectives and segments
- Integrated logistics support
- Systems monitoring and support

Training

Preflight

- Leadership training
- Training analogs (e.g., field geology training)
- Simulation concepts for field and part task training
- Contingency training for failure models and emergencies

Inflight

- Systems training
- Part task training
- Periodic emergency training
- Simulation for Mars operations
- Mission activity training (e.g., surface equipment training, geology training, etc.)

Mission Control and Support

- Integrated throughout all phases

Ground Support and Facilities

- Integrated throughout all phases

quirements must be standard. Spares are only required for certain designated critical items. No system should be designed to preclude repair or maintenance assessments. Also, improved maintenance concepts must be developed for support of facilities and vehicles during long term surface operations.

Training

The astronauts needed to support the lunar and Mars missions will require a variety of skills. Piloting skills will be a prerequisite for performing the various space maneuvers and tasks associated with the landings on the Moon and Mars, the ascents, rendezvous and dockings. The lunar and Mars surface activities will require crews well trained in extravehicular activity; mission specialist astronauts with science skills, such as geology and life sciences; as well as mission specialists with engineering and construction skills.

It will be important to constitute a cadre of astronauts with the prerequi-

site skills well in advance of the initial lunar landing. It will be equally important to constitute a training program to insure pilots and mission specialists are trained on the various surface tasks to insure the effective utilization of personnel.

A training plan provides a structured and systematic process for all mission increments. The Mars missions require new approaches to inflight proficiency training. The capability for the crew to conduct ascent, descent and transfer simulations using the cockpit of the transfer vehicle for the simulation enhances the ability to train for Mars operations.

Communications and Information Systems Support

The four architectures described require effective, efficient communications and information systems. A viable system monitors and controls mission elements, provides science data return and provides radiometric support for navigation. This support

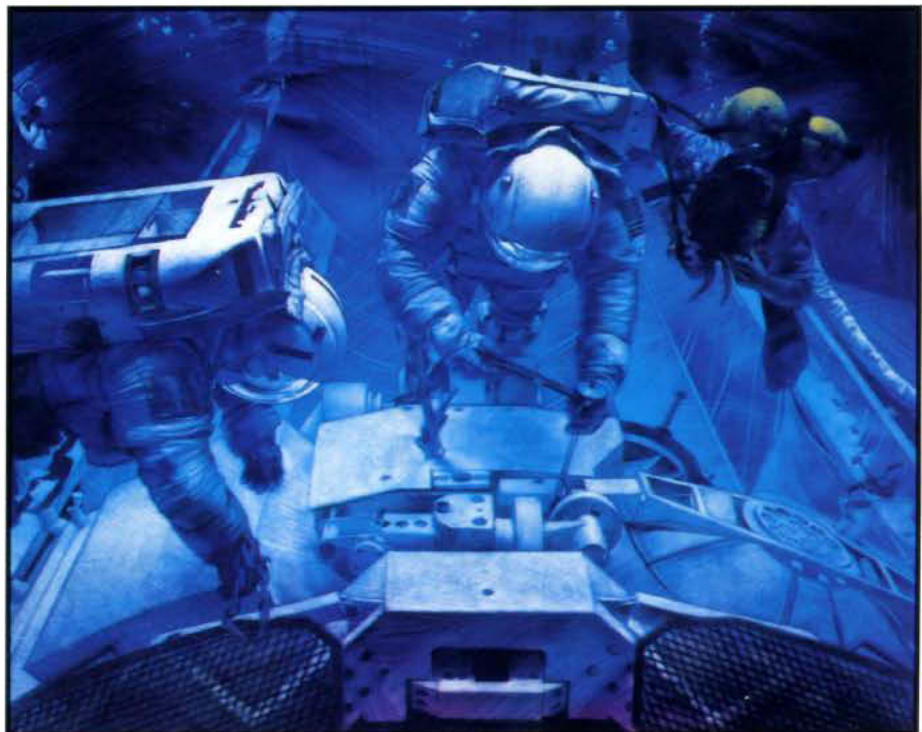

Zero Gravity Training in the Neutral Buoyancy Tank

requires reliability, consistent with human spaceflight, capable of insuring support to all key mission elements.

An important objective of the Space Exploration Initiative is to disseminate information to the public. This includes involvement of educational institutions at all levels. High definition video as well as other image data is widely used in achieving this objective. Thus, communication bandwidths are sized to accommodate these requirements.

NASA already has a significant capability for tracking and data acquisition, data distribution and information processing. NASA plans significant upgrades to some of these systems to support future programs such as the Mission to Planet Earth. It is very important that data system standards be selected which are consistent with all the systems supporting other civil space missions.

The NASA Tracking and Data Relay Satellite System and the infrastructure used to support Earth orbiting missions are expected to be modified to support the launch and near-Earth support of all Space Exploration Initiative missions.

Moon Communications

The operational segments of the architectures include hardware and crews located on the near side of the Moon with an activity area of up to 100 km from the landing site. The data types anticipated to be used in this area include audio, video, image, science and engineering telemetry, and radiometric data for navigation.

Based on accessibility, risk and an expected lower implementation cost, Earth-based antennas are baselined to meet the lunar communications requirements. This approach assumes the installation of two 34 m antennas at each of the existing Deep Space Network locations at Goldstone, California; Madrid, Spain; and Canberra, Australia. Each antenna could support one uplink and four downlinks.

If it is assumed that one antenna is used to provide near-continuous support to the main base, then the outlying elements and in-transit spacecraft need to share the link resources of the other antenna. This configuration does not provide continuous visibility of the Moon and gaps in coverage of approximately 30 to 60 minutes occur each day in certain lunar phases. This is deemed to be acceptable for the proposed architectures, but these gaps could be eliminated by additional ground terminals.

Lunar surface communication between elements within a 10 km radius around the main base are provided by a surface terminal also providing the communications connection to the Earth stations. Communications between the main base and elements outside the 10 km radius must be through the Earth stations.

Communications between the Earth stations and mission support locations on Earth are provided by existing networks, modified as required, to accommodate lunar mission requirements.

Mars Communications

Providing communications for the Martian missions is considerably more challenging than for lunar missions. Mars can be as much as 1,000 times more distant from Earth than the Moon, which results in a spatial signal loss one million times greater. In addition, Mars rotates at about the same rate as the Earth, putting surface locations out of direct touch for over 12 hours at a time.

The architectures developed for Mars propose the following types of missions:

- Site reconnaissance orbiters
- Mars global network
- Cargo flights supporting human missions
- Human missions

Mars synchronous relay satellites could be used to provide continuous coverage of Mars surface elements as well as orbital elements. The Martian main base and piloted Mars vehicle should also have the capability of communicating directly with Earth when in view.

The Deep Space Network stations could provide support to in-transit spacecraft, the relay satellites and surface elements. In considering the data volume requirements, space element power levels and antenna sizing, it was concluded that K-band could be used for the Mars communications system. Due to the distance to Mars, the communications system is constrained in the volume of data that can be transmitted. A 5 m diameter antenna at Mars, transmitting 70 watts to a 70 m antenna on Earth,

would provide a data rate of 10 Mbps. For cost and redundancy reasons, four 34 m antennas were chosen to provide the equivalent aperture of a 70 m dish. This configuration will require the addition of four 34 m antennas at each Deep Space Network location.

X-band would be used for the forward link, since that technology exists in the Deep Space Network and meets the data requirements with growth to approximately 10 Mbps. It is expected that all local Mars positions would use K-band for inter-element communications.

The Deep Space Network radiometric navigation capabilities will be used to provide updates to onboard systems for all missions. As with the lunar case, the NASA institutional data processing and distribution sys-

Figure 1

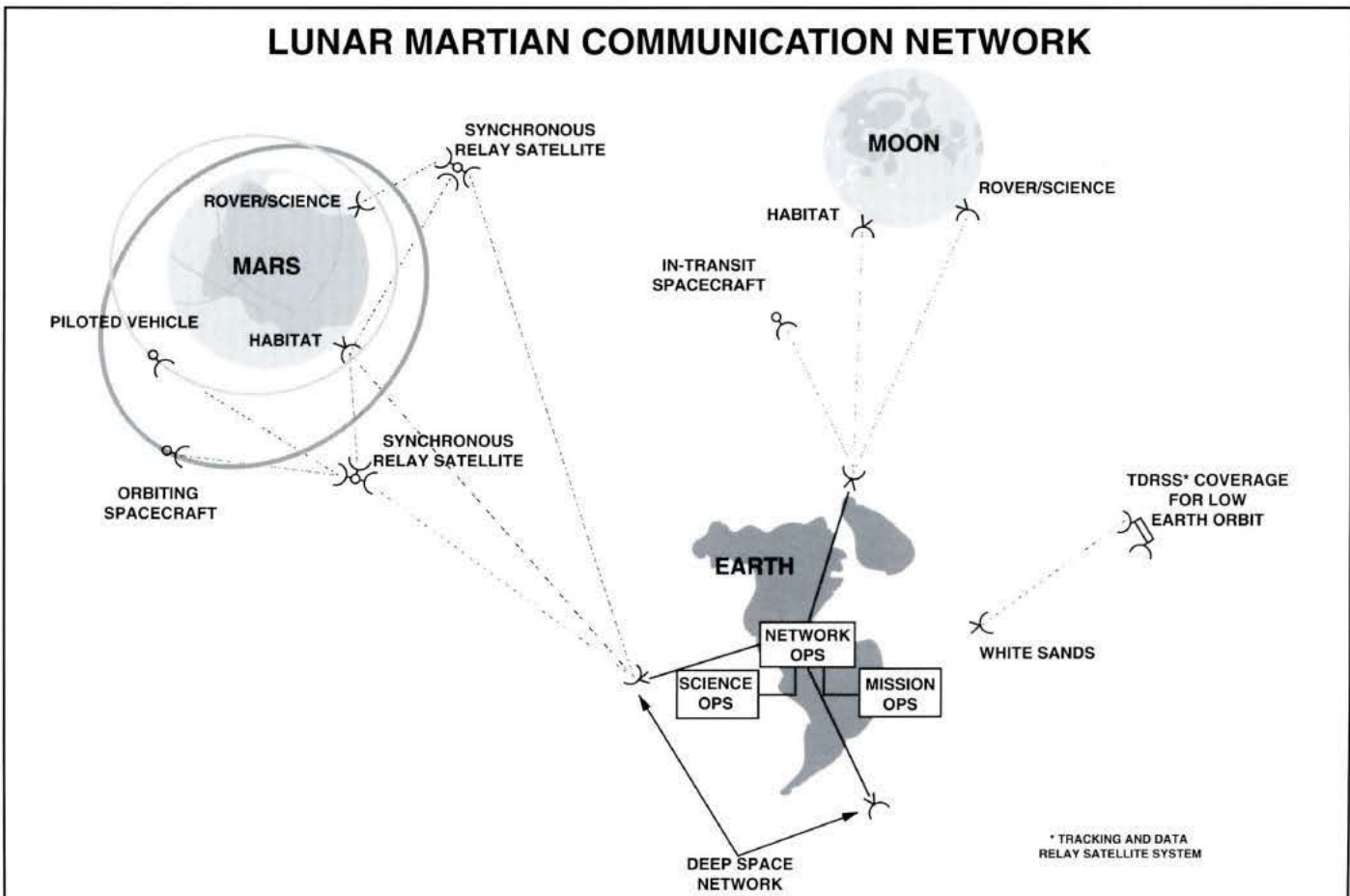

tem will require a capacity increase to accommodate the Mars missions.

Given the communication delay times and the requirement for mission control to be largely a function performed by the crew, the local communications system at Mars will also be rather complex and should operate automatically, having only minimal interaction with Earth terminals. This represents perhaps the greatest challenge in implementing the communications infrastructure for the Mars missions. The relay satellites at Mars must automatically perform onboard signal acquisition, tracking, handover, etc. Figure 1 illustrates both the lunar and Martian communications networks.

Navigation

The missions to the Moon and Mars will require navigation support beyond low Earth orbit in the following general areas:

- Enroute
- Orbital operation
- Landing
- Surface operation
- Ascent
- Rendezvous and docking
- Earth entry and landing

Planetary missions are currently supported by the Earth-based navigation capability of NASA's Deep Space Network. This system provides state vector information by processing Deep Space Network tracking data and onboard optical data at a central navigation center. For the Space Exploration Initiative program, it is expected that a navigation center will be established as part of a central control facility which will be supported by an upgraded Deep Space Network system. Based upon the lunar mis-

sions contained in the proposed architectures that confine surface operations to the near side, it is expected that an Earth-based system can meet the navigation requirements. The navigation center will provide state vector updates to the spacecraft onboard inertial systems and position information for surface elements.

The Mars missions will have real time in situ navigation needs that cannot be met by an Earth-based system due to the communication delay times. This requires the primary mission elements to have an onboard navigation computation capability. It is envisioned that the Earth-based system would provide the primary navigation updates during most of the transit time to Mars. When the spacecraft nears the planet, the onboard system becomes primary and uses measurements taken from radio sources such as relay satellites, surface beacons and optical observations of the Martian moons and stars.

While on the surface, the onboard system provides real time navigation support services based upon Mars-centered parameters. Surface navigation for rovers, calibration of surface beacons, and backup of the in situ system will be provided by the Earth system. The Earth system would also provide the primary support for the return and Earth entry and landing.

Facilities

The architectures outlined require the support of a substantial number of Earth-based facilities. Since the Space Exploration Initiative touches virtually every scientific field and engineering discipline, there is a need of a like range of facilities, from a simple track for testing rovers to a highly sophisticated facility for developing long term blood storage capabilities, and related technologies. Many of these facilities presently exist throughout industry, government and academia,

Surveyor III and Astronaut with Lunar Excursion Module, Apollo XII

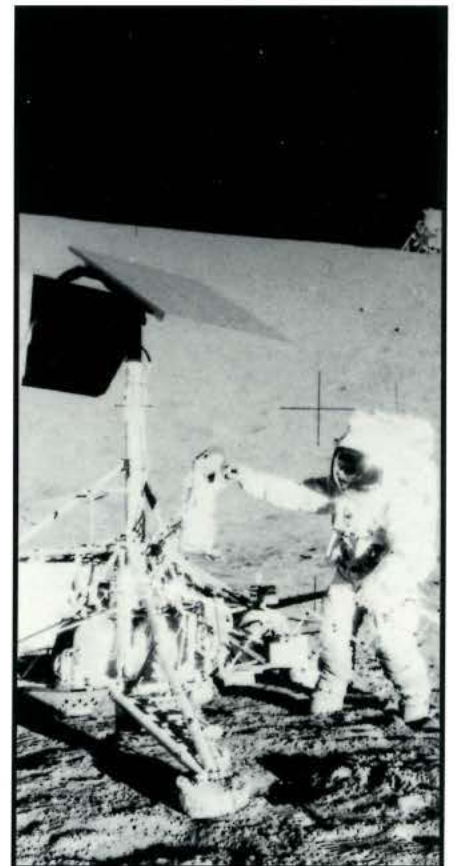

though some will require modification. New facilities are also required.

Heavy Lift Launch Vehicle Facilities

The development, manufacture, assembly and test of the heavy lift launch vehicle is as essential as Saturn V was for the Apollo program.

However, with the experience that has been gained on Saturn and subsequent programs, it will not be as formidable as the Saturn program was in the 1960s.

Launch Facilities

To support the Space Exploration Initiative operations at the Kennedy Space Center, a minimum of two launch pads will be required to support an additional launch rate of eight to 12 launches per year for the Mars mission. This assumes continued use of existing pads to support launches for the Space Shuttle and expendable launch vehicles. Four transporters and two new vertical assembly building cells, or a new building, would be needed for the parallel processing of two heavy lift launch vehicles.

Nuclear Test Facilities

Facility requirements associated with nuclear technology development include reactors for testing fuel ele-

ment concepts, assembly facilities for developing reactors, and integrated ground testing facilities. Much of the reactor development activity can take place within existing governmental or commercial nuclear research facilities. Multiple facilities may be necessary to support the parallel development of both nuclear power and nuclear propulsion systems.

Development testing of nuclear thermal rockets will require new test facilities with the capability to remove any radioactive nuclei from the exhaust.

Space Radiation Test Facility

The Initiative requires a definitive assessment of the radiation risks incurred in space environments. To support this assessment, accelerator facilities capable of simulating galactic cosmic radiation and solar particle events of appropriate energies are required. These facilities will be used to obtain measurements of radiation effects on biological samples to provide a well-correlated database with space experiments effects. They will also be used to investigate the energy, particle type and reaction mechanism dependencies to support the development of an integrated biological model for use in space radiation risk assessment.

The one facility in the U.S. capable of providing simulated heavy element radiations of appropriate energies, the Berkeley Bevalac, will be decommissioned for nuclear physics in 1992. A new facility, the Brookhaven Booster, presently under construction, will be commissioned in 1994.

Closed Loop Life Support System Test Facility

The development of a closed life support system for Moon and Mars habitats represents a significant technological challenge to the Space Exploration Initiative. A facility is required to test and verify subsystem and integrated system technologies

Kennedy Space Center Launch Facilities



and to verify long term efficiency and reliability of the closed life support system design.

In situ Resource Utilization Facilities

The development of in situ resource utilization techniques for process engineering requires a facility to support development and validation of techniques (including the collection of volatiles from lunar regolith) and demonstration units.

Command and Control Center Facilities

The control of the Moon and Mars missions differs significantly from previous missions flown because of the duration of the missions and the communications delay to Mars, as well as the desire to use the Moon to simulate and verify Mars operational protocols. As a result, operations will have a higher degree of autonomy for command and control of critical functions and the planning of near term activities. However, certain functions and activities must still be conducted and supported on the Earth, so there is the need for a central control facility to support these functions. Advances in technology and autonomy will greatly improve the flexibility and efficiency of operations.

The central control center must have a supporting communications infrastructure, allowing communication with the launch control center, vehicles on the pad, vehicles in low Earth orbit, other supporting ground control centers and installations, vehicles enroute to the Moon or Mars and surface facilities on the Moon or Mars. In addition, the control center must be capable of tying in with simulators to simulate mission scenarios. The experiences gained from Apollo and the Space Shuttle clearly emphasize the importance and advantages of having the simulation facilities at the same site as the control center for logistics and communication support as well as for ensuring integrated crew and

flight operations planning and training.

Training Facilities

High fidelity simulators are necessary to train crews to operate together as teams. Although static mockups, computer simulations and motion based vehicle simulators can be used to augment training prior to flight, all piloted vehicles must have an embedded training simulation mode so that proficiency training of critical maneuvers for the crew can be an ongoing process. These allow the crew approaching Mars to continue rendezvous and docking training and to conduct ascent, descent and transfer simulations. The crew can also practice ascent simulations in the Mars lander prior to departure from the planetary surface. Rovers, likewise, could have a simulation mode so that crew members can maintain proficiency on operational techniques in the simulation mode before venturing out onto the planetary surface. Computer simulations will also be available on board for payload and other proficiency training.

High fidelity Earth-based simulators are required for all piloted transfer vehicles, landers, rovers and robotic or telerobotic support equipment. These would include static and motion-based simulators.

Geology training would be accomplished at appropriate locations on Earth as was done for Apollo, to prepare for exploration activities on the Moon and on Mars.

Apollo Astronaut Geology Training

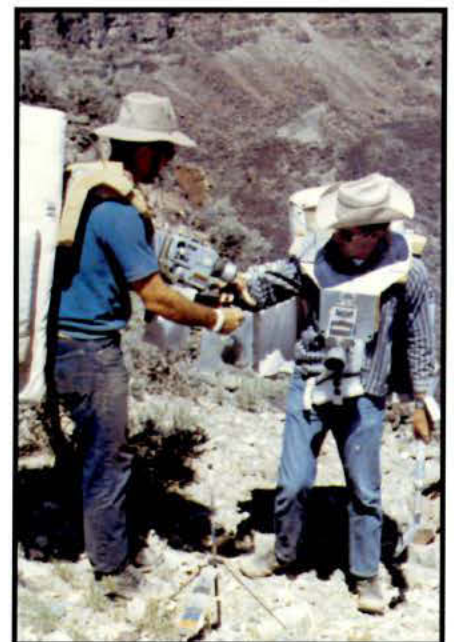

The Space Exploration Initiative represents a major evolution in scope when compared to any previous human spaceflight program. The Mercury program was designed primarily to demonstrate the feasibility of human spaceflight, and successive efforts have progressively expanded our understanding of human response to spaceflight.

Health maintenance and medical care will be crucial to the Space Exploration Initiative. Missions to the Moon and Mars will expose crew members to reduced gravity and to radiation, both potentially harmful. Human factors considerations are important for crew selection, interpersonal relationships, and human-machine interfaces. These and other factors must be reflected in the design of space vehicles and missions for human exploration.

Spaceflight Deconditioning

The experience from both the U.S. and Soviet programs has shown that zero gravity has profound and varied effects on human physiology, result-

ing in a broad range of responses that vary in nature according to the duration of exposure and use of countermeasures. This process of adaptive responses, termed "spaceflight deconditioning," can compromise mission objectives if not appropriately managed. The key physiological systems affected by extended exposure include:

The Cardiovascular System: This system undergoes a complex adaptation which includes both functional and structural changes. Primary operational concerns involve low blood pressure and abnormal heart rhythm.

The Musculoskeletal System: Bones and muscles lose mass in space. Bone loss also results in an increased risk of kidney stones and an increased risk of fracture in flight as well as post-flight.

The Neurological System: The neurological system undergoes an adaptation which results in a number of concerns. Space motion sickness can occur early in flight and can be a problem until the body adapts to zero gravity.

The Hematological, Immunological and Endocrine Systems: Anemia and immune system dysfunction need to be studied further to understand the long term medical implications. The human endocrine system, affected in a multitude of ways which could impact crew health, requires further study.

Extended exposure to zero gravity results in profound changes in human physiology. This must be understood in order to modify the course of spaceflight deconditioning and enable the delivery of medical care in space, since acute medical care decisions are often based on changes in underlying physiological indices.

Another concern is the effect of reduced gravity on a crew member

Space Shuttle Medical Evaluations

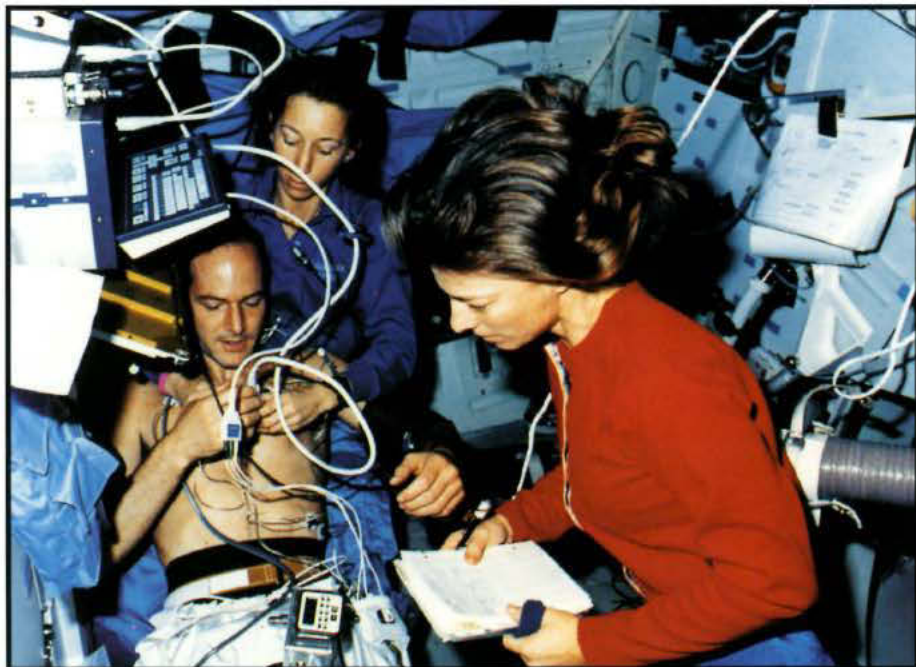

already deconditioned by exposure to zero gravity. The crew must have adequate physiological reserve to perform assigned duties.

The effects of deconditioning from extended stays on planetary surfaces also needs to be better understood to determine if there are any adverse effects on crew performance during long missions.

Space Radiation

The Space Exploration Initiative program requires understanding and management of space radiation hazards. A multidisciplinary radiation issues research program involving solar physics, nuclear physics, radiobiology, and probability risk assessment will have a major influence on spacecraft design, habitats and mission planning. Such a program should be able to qualitatively and quantitatively determine the energy, particle type, and reaction mechanism dependencies necessary for biological and mechanical space radiation risk assessment. Generation of additional physics data characterizing galactic cosmic radiation, solar particle events, and solar dynamics will enable the development of reliable predictive models of the radiation environment.

Uncertainties in these radiation effects on cells, tissue and small organisms could be reduced by simulations using the Bevalac at the Berkeley Radiation Laboratory or the Brookhaven Booster Facility. Radiation shielding requirements should be established with an inter-agency effort between NASA, the Department of Energy, and the Department of Defense. Ground and space-based facilities and programs must be started now to be in place and fully operational by 1995. An expanded ground based simulation program will be used as a basis for radiation environment and shielding models; however, space experiments will be needed for validation.

Medical Care

Within the U.S. space program, inflight medical illness has resulted only in minor mission impacts. In contrast, the Soviet space program, where missions are often lengthy, has been impacted by inflight medical contingencies. Their contingencies resulted in either a mission abort or replanning on several occasions. While predicting the likelihood of medical illness or injury inflight is difficult, it is reasonable to assume that medical contingencies will probably occur in the course of an ambitious and sustained exploration program.

The objective of inflight medical care is one of risk management. Crew health can be affected by a number of factors.

Given that crew illness or injury has the potential to impact mission objectives and crew productivity, an adequate medical care capability should be provided for all phases of the exploration program. Computer-

Solar Eruption Photographed from Skylab

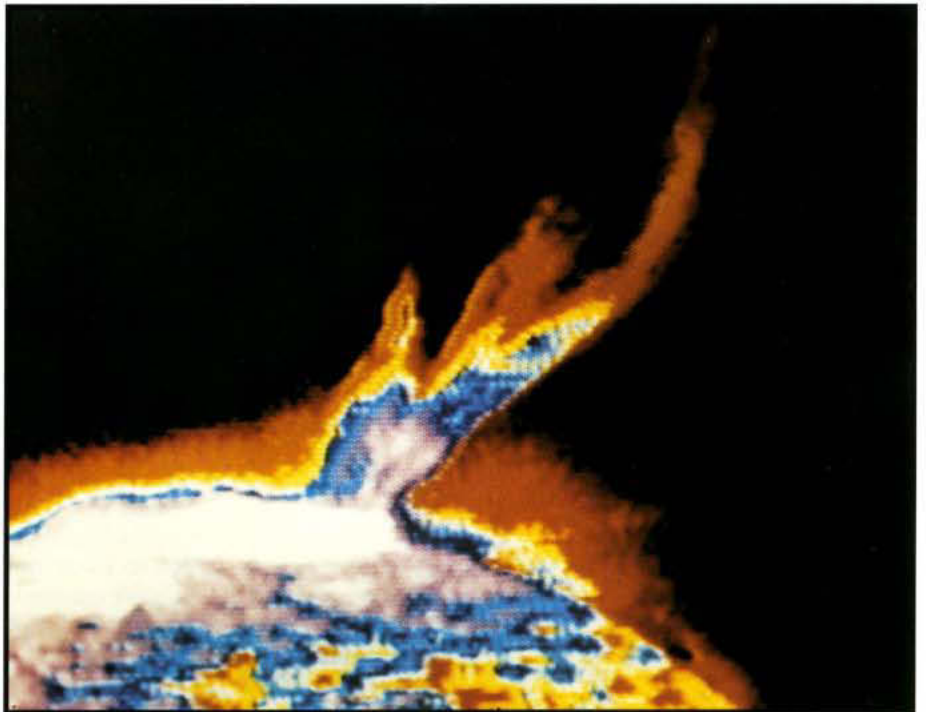

based medical and compact diagnostic systems, extended life pharmaceuticals, blood substitutes (or freeze-dried blood) are needed for the Mars missions.

Life Support Systems

Conducting operations in space requires that provisions be made for protecting people from its hostile environment. Human physiology possesses a remarkable degree of adaptability, but humans can only survive in an environment characterized by rather narrow thermal and atmospheric limits. The materials needed to sustain life can either be brought from Earth or, with the right technology, created in place from wastes or in situ resources. This tradeoff between logistical resupply, regeneration and manufacturing is embodied by the concept of loop closure.

U.S. space programs to date have employed open loop system design, with no reuse of waste products. Wastes are stored for return to Earth or are vented overboard from the spacecraft. Initial efforts at partial water loop closure have been undertaken on the Soviet Mir station. However, further work on the type of closed loop systems critical to the success of the Initiative needs to be accomplished. Creation of closed loop life support systems based on regeneration of waste products represents a radical departure from the existing experience.

The cost of resupplying open loop life support systems for the conduct of extended duration missions or operations away from the support systems of Earth may lead to closed loop life support systems becoming a requirement. In order to limit the requirement for life support consumables, certain components of the waste stream must be recycled.

The basic subsystem functions traditionally included in life support include the following:

- Temperature and humidity control
- Atmosphere control and supply
- Atmosphere revitalization
- Water reclamation and management
- Waste processing
- Fire detection and suppression

These activities form the basis of the Environmental Control and Life Support System. Other life support functions which must be addressed include food supplies, system control, and local resource utilization.

The design of the Environmental Control and Life Support System is interrelated with a number of key operational considerations. Most important of these is the selection of the atmospheric parameters for exploration spacecraft and habitats. The selection of a hypobaric, normoxic atmosphere, such as utilized for Skylab (5 psi total pressure with an approximate 70/30% mixture of oxygen and nitrogen, respectively), allows the principal advantage of conducting extravehicular activities with minimal prebreathing. Another benefit of a lower operating pressure is reduced leakage rates.

The main drawback outside of unknown, long term physiological effects, is reduced cooling and heat dissipation. While a reduced pressure, oxygen-enriched atmosphere results in concentrations of oxygen which are equivalent to sea level atmosphere, the body is subject to a

total pressure which is approximately one-third of that on Earth. Although the Skylab missions have demonstrated the feasibility of working in reduced pressure for up to 84 days, a number of physiological changes have been documented.

The physiological effects of living in hypobaric environments for extended periods of time are not known at present. While they do not appear to result in any gross disruption of physiological processes, the long term effects and the interaction with the effects of zero gravity exposure need to be characterized. The effects of extended hypobaric exposure should be studied as a component of a ground-based research program. Specialized facilities such as altitude chambers will be utilized for this research.

The development of life support systems with high efficiency and reliability represents the area of greatest technical emphasis in the life sciences area. A developmental program should focus on both subsystem and integrated system technologies, as well as a core research program to evaluate applicable physical-chemical processes.

Human Factors

Human factors address the issues relevant to human interface with a variety of systems. In the past two decades, there has been an increasing awareness of the value of human factors in the design of work environments. The missions proposed in the exploration program would expose crew members to a unique combination of stresses and hazards for long periods of time. Effective integration of human factors considerations into mission design results in two primary accomplishments: a) the human would be physically and mentally able to do the tasks outlined, and b)

all the systems, equipment, spacecraft, rovers, vehicles, tools, etc., will be designed so the tasks can be efficiently accomplished.

Specific human factors issues include:

- Habitat design, including usable volume and space allocation
- Human-machine interfaces
- Psychological and psychosocial considerations, such as crew selection, small group dynamics, provision for recreation and optimal crew size and mix
- Environmental and physical considerations such as lighting and ventilation

Astronaut Loading Equipment on Lunar Rover, Apollo XVI

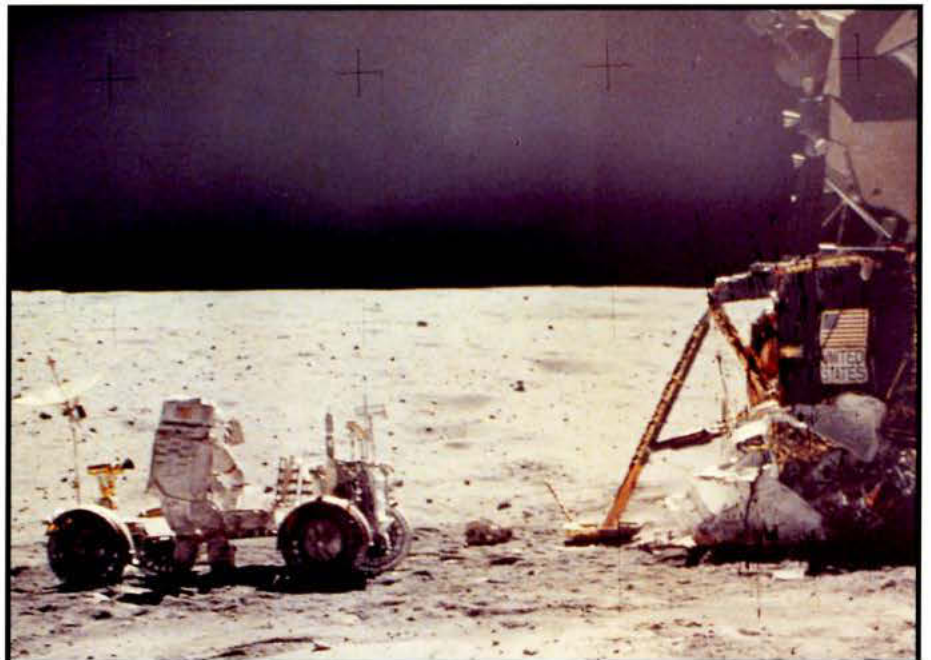

Conclusions

Cumulative experience from both the U.S. and Soviet space programs has resulted in an initial characterization of the human response to spaceflight. Exploration missions present numerous challenges relative to previous programs.

Space Station Freedom can represent the transition within the U.S. space effort to a sustained presence in low Earth orbit. Planning for exploration missions has identified a space station as the primary zero gravity platform for conducting life sciences investigations. This orbital test bed would provide first generation capabilities, particularly spaceflight deconditioning countermeasures, the development of medical procedures and facilities, and the development of closed life support systems. The Report of the Advisory Committee on the Future of the U.S. Space Program recommended that "the justifying objectives of Space Station Freedom should be reduced to two: primarily life sciences, and secondarily microgravity experimentation." If this recommendation is implemented, then the space station would be utilized to resolve the life science issues critical to a Mars mission. However, program reviews in the past two years have resulted in restructuring and delaying the space station. These programmatic changes call into question the availability of life science data in a timely manner.

Missions to the Moon can be initiated without resolving many of the life science questions that must be resolved for the Mars mission. All of the architectures require lunar activity prior to initiating a piloted Mars mission. It is therefore logical to consider the concept of utilizing the Moon as a preparatory environment for a Mars mission to integrate a number of key life science and operational requirements. There is a compelling argument for the deployment of a first-generation Mars transfer vehicle

(crew compartment) in lunar orbit. This zero gravity test bed would allow development and validation of key life support technologies and human factors design, and would function as a platform for conducting essential biomedical investigations into spaceflight deconditioning. Additional rationales for a Mars transfer vehicle in lunar orbit include validation of radiation shielding provisions developed for Mars excursions and conduct of radiobiological experiments to refine dose-effect models.

The use of the Mars transfer vehicle, in conjunction with a surface emplacement on the Moon, would allow mission-critical studies into the physiological effects of fractional Earth-normal gravitational exposures following extended zero gravity stays. This objective can be accomplished with a high degree of operational fidelity on the Moon, and the ready access to zero gravity or fractional gravity would permit a rapid accumulation of data. Simulations of Mars gravity on the lunar surface, using a weighted spacesuit, would allow refinement of gravity-response curves.

The Mars transfer vehicle would have a number of other key missions in addition to life science activities, including simulations of Mars missions complete with excursions to the Martian (lunar) surface and return, the use of an orbital platform for lunar or astronomical observations, and as a test bed for other essential Mars transfer vehicle subsystem development.

This approach, which integrates several key life science requirements with other exploration objectives, should take advantage of existing assets, specifically the Shuttle and the Soviet Mir space station, to initiate an early start on key life science issues. The Shuttle is an ideal platform for developing and testing zero gravity countermeasures and validating life support system hardware. An

aggressive ground-based research effort will be a critical element, leveraging the effectiveness of inflight investigations.

The recent increase in joint U.S. and Soviet cooperation in the life sciences is an encouraging development. For the present, Mir represents the only extended duration spacecraft in

operation, and access to Soviet crews for joint medical studies represents a tremendous windfall that adds to the existing knowledge base. This resource represents a timely start on key medical and physiological concerns and should be aggressively pursued.

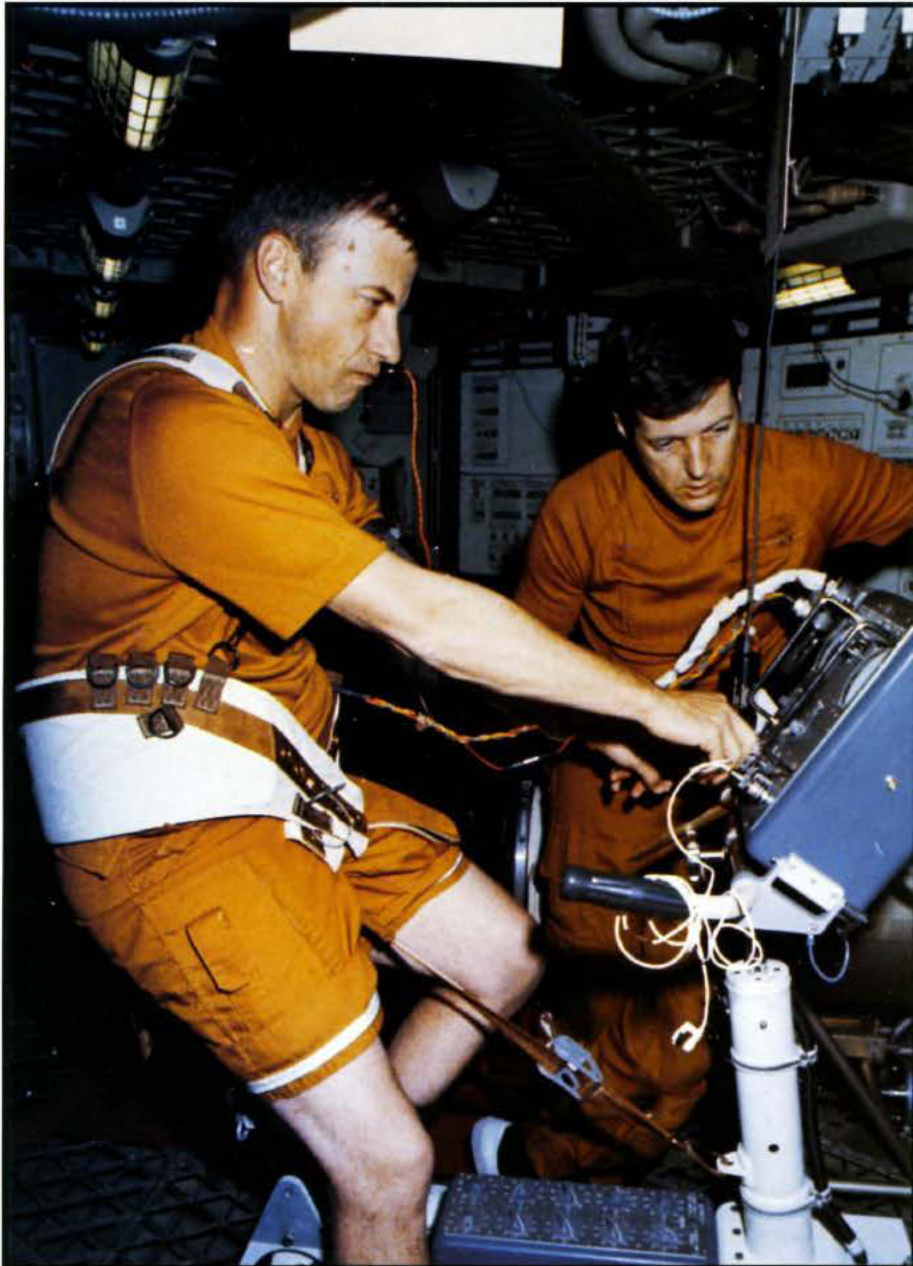

Skylab Bicycle Ergometer

"The Space Exploration Initiative is the cornerstone of my administration's far-reaching plan for investing in America's future. . . Our space program will help rekindle public interest in science and mathematics, and revitalize an area of our educational system. . ."

President George Bush

In the United States today, mounting evidence shows a significant decline in the quality of education in science and related fields, including mathematics, engineering and technology. In a recent Columbia University Teachers' College study, American students ranked in last place among 16 countries in overall performance in science.

Since 1986, fewer American college students are earning degrees in science and engineering, a trend which is projected to continue through the end of the century. The National Science Board estimates that the demand for scientists and engineers will increase by about 34% during the next decade, while the total number being trained will increase by only 8.5%. Therefore, the country will need scientists and engineers in greater proportion to the number of graduates. Moreover, these estimates do not include the anticipated needs of the Space Exploration Initiative.

Poor student performance, projected work force shortages and public scientific illiteracy are drawing attention to the need for rejuvenation and reform in the American educational system. Speaking before the nation's governors in 1989, President Bush articulated six goals for American education. A major goal was that U.S. students should be number one in math and science in the world by the year 2000.

The Role of the Space Exploration Initiative in American Education

The Initiative has much to offer American educational efforts, and at the same time, the Initiative depends on effective education for success.

The excitement of space exploration continues to capture the imagination of young people, as it did during the Apollo era. The Space

President Bush at Space Camp



Exploration Initiative provides a way to excite the minds of the nation's students, attracting them to the study of mathematics and science; it also provides a vision for the future, giving focus and application for mathematics and science studies. Additionally, the new discoveries from the Space Exploration Initiative will lead to new developments in science. In much the same way, the technical requirements of the Space Exploration Initiative will spur new engineering and technology developments. Finally, the Space Exploration Initiative will foster new information management and communications technologies which will bring the excitement of discovery and exploration directly to the classroom.

The Space Exploration Initiative depends on the success of the science, mathematics, engineering and technology education initiatives now underway. The goals of the Space Exploration Initiative cannot be achieved without talented individuals to solve the technical challenges. New technologies cannot be implemented without a technically competent work force to build, maintain and operate them. A well-prepared work force should be considered as necessary to the fulfillment of the Space Exploration Initiative as any technical challenge.

The Benefits

Historically, well-educated, technically sophisticated nations have led the world, providing the best standards of living and opportunities for their people. Improving mathematics, science, engineering and technology education in the United States will impact all areas of American life. In the broadest sense, more Americans would have an improved understanding of the universe and mankind's place in it. But the benefits are also practical: improving the level of science education would provide for the development of a technically competent work force. In turn, tomor-

row's scientists and engineers would create the technology base of the future. Combining creative technical ideas with a skilled work force will provide for the future growth of the U.S. economy, improving our competitiveness and our position as leaders in the world.

The Education Process

To provide for the scientists, engineers and technicians of the future, the challenge is twofold: first, to attract young students to mathematics and science, and second, to keep them from leaving the field. The challenges and solutions differ by age groups, and the education program should be tailored to meet a variety of needs.

From kindergarten through the second year of college, the Space Exploration Initiative provides interest and enthusiasm for young minds, drawing them into the pipeline and giving them a set of goals to focus their studies. The investment is long term, providing for a larger pool of talent from which the Space Exploration Initiative can draw its future workers.

Beyond the second year of college, the relationship between the Space Exploration Initiative and education becomes more direct. In the upper levels of undergraduate training and in graduate school, research is the primary means for education. University research for Space Exploration Initiative-related subjects will serve to train graduate students. At the same time, their research will produce the scientific ideas and technological developments on which the Space Exploration Initiative is built.

Future students will need to appreciate and select career opportunities in science and technology. Many different factors may contribute to a decision to enter a career in science and technology. At the pre-college level, career goals are often set by personal interest, which can be fostered

by a good education. Indeed, the majority of scientists and engineers today had decided to go into the field before the end of high school. In addition, career guidance and counseling can have a deciding influence. Most importantly, however, career choices are determined by the availability of jobs. The Space Exploration Initiative promises a great opportunity for the employment of future scientists and engineers.

In reality, many of the young scientists and engineers will have careers outside the Space Exploration Initiative. They will have benefited from the improvements to the overall mathematics, science, engineering and technology training resulting from the Initiative, and the country will benefit wherever they choose to work.

The Education Program

The National Program Office for the Space Exploration Initiative must actively support NASA's efforts to:

Foster participation from all sectors of society. By coordinating the efforts of federal, state and local governments with the private sector and academia, duplication of effort can be avoided and the efficient use of available resources will put support where it is most needed. The Space Exploration Initiative is a multi-agency program and should draw upon the resources of all government participants. Nearly every organization or group can expect to benefit from the Space Exploration Initiative and its programs.

Leverage resources. The decline of American science education is a problem of national scope. Neither NASA nor any other single government agency can be expected to solely support its rejuvenation. However, the Space Exploration Initiative organization could provide both the inspirational leadership and provide seeds of

support to foster educational activities in any given community. With a minimal expenditure of funds, local education efforts can be maximized by drawing on local businesses and industry, local universities and colleges, and local organizations for support, materials and manpower.

Provide support for under-represented minorities. A recent study shows that 68% of the work force in the year 2000 will be made up of women and minorities. The changing demographics of the labor force demand that a means be found to attract under-represented minorities to careers in science and engineering. Special effort will have to be put forth to understand the unique needs of these minorities.

Make connections to non-technical fields. The Space Exploration Initiative is an endeavor for the entire nation, not just for scientists and engineers. The goals and activities of space exploration should be presented in their larger contexts. Placing the Space Exploration Initiative in a broad perspective can develop a deeper understanding of the role of space exploration in American society and foster appreciation and participation from all sectors of American society.

Kindergarten through Second Year of College Initiatives

The kindergarten through second year of college education programs for the Space Exploration Initiative should be developed and administered in close partnership with other federal initiatives.

The Education and Human Resources Committee of the Federal Coordinating Council for Science, Engineering and Technology recently presented an interagency budget for mathematics, science, engineering and technology education. Along with this coordinated budget and priorities for the future, their report includes a comprehensive inventory

of mathematics and science education programs and activities across the entire federal government.

The Space Exploration Initiative education program should actively participate in the activities of the Federal Coordinating Council for Science, Engineering and Technology Committee on Education and Human Resources. The Space Exploration Initiative serves as a catalyst for this education reform. These efforts include teacher preparation, curriculum reform, research and development on teaching and learning, materials generation, evaluation, dissemination and technical assistance. The Space Exploration Initiative program should not attempt to duplicate these efforts.

Over the longer term, the Space Exploration Initiative kindergarten through the second year of college education program should work closely with professional educators to develop curricular materials for use in the classroom.

Specifically, the kindergarten through second year of college education program should:

Contract for the development of classroom materials. Separate materials should be developed to draw the connection between space exploration and traditional mathematics and sciences, and emphasize the unique aspects of exploration which do not strictly fall under mathematics and science, including robotics, technologies, living in space, problem solving and the role of exploration in history.

Conduct supplemental teacher workshops to provide innovative ways to demonstrate the impact of the Space Exploration Initiative on motivating students into science and mathematics.

Expand the means to maximize the usefulness of space communications technologies, such as television broadcast providing coverage of



NASA activities (NASA Select), to directly communicate space activities to the classroom. This includes both background materials and live classroom-in-space activities.

Foster relationships with non-governmental organizations such as the National Parent-Teacher Association, professional societies, business organizations, etc., and participate in their educational activities by providing materials, speakers and guidance.

Provide incentives for school mathematics and science competitions. For example, NASA could provide for trips to a launch of the Space Shuttle at Kennedy Space Center for local science/mathematics contest winners from around the country. Such rewards could spark significant interest for little investment.

University Research

From the formation of NASA until the mid-60s, there was a concerted program aimed at supporting basic research at the nation's colleges and universities. This program succeeded in producing young scientists and engineers who made significant contributions to space programs of the next 25 years. It also formed a strong alliance between NASA and the academic community and provided a broad base of support for space exploration. As NASA funding for university research decreased in the late 60s and 70s, the number of people choosing to study science and engineering also decreased.

Support during this period consisted of contracts, grants and fellowships designed to provide sustained support to basic research teams. Included in the grants were capital funds for buildings and equipment to rebuild an aging university infrastructure.

The Space Exploration Initiative University Program

Excellence in research is the goal of the Space Exploration Initiative university program. This program should be revitalized as it was for Apollo and should again include contracts, grants, fellowships and cooperatives to support basic research. As the Space Exploration Initiative matures, the research objectives will change to match the needs of the Initiative. From basic independent research through specific project support, the Space Exploration Initiative university program must participate with other national programs to intellectually stimulate and inspire our young researchers — producing scientists and engineers to meet national needs.

Classroom knowledge must be combined with practical application, through laboratory projects and/or work in various government agencies and industry to provide the educational foundation for this excellence.

Regenerating and augmenting previously successful university programs, to include adequate funding and support, are key to implementation.

Specifically, the university program must recognize the need for a long term commitment to provide the technically educated work force needed to support the Space Exploration Initiative and national technology progress. The long term plan should:

Sponsor basic research in targeted areas through Announcements of Opportunity. A continual peer review process will maximize the return, encouraging the continuation of promising research, while terminating that which is less promising. This process insures participation from the widest possible group of the universities and researchers.

Support should include the purchase of equipment. To provide for the most profitable research, universities must have access to modern equipment. Further, linkage between universities, government agencies and national laboratories can maximize facility use while providing access to equipment and technical personnel to the universities.

Coordinate university activities with government laboratories and industry. Through exchange programs, such as cooperative programs, internships, research grants, project contracts, and the centers of excellence, students gain practical experience and foster potential future employment opportunities.

Support must be long term, based on satisfactory performance. The Space Exploration Initiative is a long term program which requires long term commitment. In particular, the Space Exploration Initiative university program must recognize the importance of commitment to graduate students attempting to complete their degrees.

The Role of Industry

The Space Exploration Initiative should support cooperative education programs and internships to place students in industry early in their training. The Initiative can foster these activities by requiring key government grants and contracts to include provision for such internships and cooperatives. Similarly, the Space Exploration Initiative should provide incentives for industry to support and participate in local educational programs and activities.

Industry can play an important role in reaching and developing students and guiding them into careers in science and engineering. Industry

is already well aware of the benefits of attracting students early. First, the students are able to make a real contribution to the contractors' efforts. Second, the students gain valuable industrial experience which enables them to contribute immediately after they finish their education. Finally, industry gets an early and inexpensive look at the best students, and has the advantage in hiring them after their education is complete. Well-trained and educated employees provide the key to the future competitiveness of the company.

Informal Education and Public Outreach

Beyond the classroom, a wide range of informal space-related materials, activities and organizations exist. With the growth of the Space Exploration Initiative and increased public participation, additional interest will be generated in these activities.

Informal educational opportunities include:

Space Organizations. Over the past decades, numerous space-focused organizations have formed, including grassroots organizations, camps, museums and activity centers. Examples include the Challenger Center for Space Science Education, the U.S. Space Camp, the U.S. Space Foundation, the National Space Society, the Planetary Society, the Young Astronauts and the Astronaut Memorial Foundation. These organizations provide opportunities for participatory learning.

Educational Media. Educational television networks, available through cable and satellite transmission, represent an important informal educational resource, readily available for public viewing. NASA

Select television falls into this category and represents a vastly underutilized resource.

Entertainment Media. Beyond the educational media, entertainment media such as movies and television provide a powerful means to spark the public's imagination and generate interest in space endeavors.

Informational Databases. A number of informational databases are available to individuals by computer and modem connection. Public systems, such as NASA-LINK, operated by the Marshall Space Flight Center, and Space-Net, operated by the U.S. Space Foundation, are examples of this resource. In addition, commercial and private electronic bulletin boards provide technical information, file-sharing and message exchange capabilities throughout the nation.

Public awareness and appreciation of space activities is important to the Space Exploration Initiative. The National Program Office can support these informal education activities by:

- 1) Increasing public awareness of the many educational opportunities available and providing information on how they can be readily accessed

- 2) Supporting the programs and activities of space-oriented interest groups by providing materials, guidance and speakers
- 3) Providing short term seed money in the form of small grants to new informal education initiatives, to encourage the development of activities in local communities

All of these represent potential opportunities to expand the interest and awareness of Americans of all ages in the sciences and technical areas of endeavor, and to emphasize the many ways in which an active space exploration program contributes to the general advancement of our society.



"...I think you have to go to the Moon and to Mars, because we need to get smarter faster and apply what we learned to help us solve problems of tomorrow. This is the most capable nation on the planet and we are ho-humming our way into the future. I feel very serious after talking to a lot of people that we are not making enough progress in advancing science and technology for our grandbabies. We have a war on poverty, a war on drugs, and a war on crime, but the war we need to win if we are going to be successful in the next century is the war that nobody realizes we are in — and that's the war on ignorance. If you can win the war on ignorance you can win all the other wars in the process. H. G. Wells once said: 'The future is a race between education and catastrophe.' Every day millions of examples are telling us just how right he was. Now we better get on with that race because we may not have a lot of time."

John Young, August 17, 1990

*Gemini III, Gemini X
Apollo X, Apollo XVI
STS-1, STS-9*

Specific recommendations are provided for the effective implementation of the Space Exploration Initiative.

RECOMMENDATION 1

Establish within NASA a long range strategic plan for the nation's civil space program, with the Space Exploration Initiative as its centerpiece.

“. . . the jewel represented by the vision of a seemingly unattainable goal, the technologies engendered, and the motivation provided to our nation's scientists and engineers, its laboratories and industries, its students and its citizens. Hence that the Mission from Planet Earth be established with the long term goal of human exploration of Mars, underpinned by an effort to produce significant advances in space transportation and space life sciences.”¹

A strategic plan will provide decision points to allow flexibility during the life of the program, concentrate management activities of diverse departments, provide budget guidelines and identify technology pathways. The plan must be based on a detailed governmental (NASA, the Department of Defense, the Department of Energy) analysis of the Synthesis Group's four architectures. This analysis should result in further refinement to gain sufficient detail to support relative costing of the architectures. Existing and planned programs should be reviewed for their contributions to this plan. Industry effort should be limited to studying elements of the architectures. As the strategic plan's centerpiece, the Space Exploration Initiative complements the goals of Mission to Planet Earth.²

RECOMMENDATION 2

Establish a National Program Office by Executive Order.

This organization would include Department of Defense and Department of Energy personnel working directly for the National Program Office. With the multi-agency nature of the National Program Office, an Executive Order should be issued to cite the basic charter of the organization, the leadership role of NASA, and the cooperative relationship among various governmental departments and agencies. The Executive Order should clearly enumerate the the staffing, budgeting and reporting relationships and responsibilities of the affected agencies.

RECOMMENDATION 3

Appoint NASA's Associate Administrator for Exploration as the Program Director for the National Program Office.

This is required to ensure clean lines of management authority over a large, complex program while simultaneously providing a focus for NASA's supporting program elements.²

RECOMMENDATION 4

Establish a new, aggressive acquisition strategy for the Space Exploration Initiative.

The Space Exploration Initiative should standardize acquisition rules for the agencies executing the Initiative's various projects. The most streamlined processes available should be adopted for that standard. The Space Exploration Initiative is so

“Far better it is to dare mighty things, to win glorious triumphs, even though checkered with failures, than to rank with those poor spirits who neither enjoy nor suffer much, because they live in the gray twilight that knows not victory nor defeat.”

Theodore Roosevelt

great in scope that it cannot be executed in a “business as usual” manner and have any chance for success. The Space Exploration Initiative National Program Director should be designated as the Head of the Contracting Activity. This will allow the director to establish the optimum acquisition procedures within the Federal Acquisition Regulations. Multi-year funding should be provided.²

RECOMMENDATION 5

Incorporate Space Exploration Initiative requirements into the joint NASA-Department of Defense Heavy Lift Program.

The Space Exploration Initiative launch requirement is a minimum of 150 metric tons of lift, with designed growth to 250 metric tons. Using Apollo Saturn V F-1s for booster engines, coupled with liquid oxygen-hydrogen upper stage engines (upgraded Saturn J-2s or space transportation main engines), could result in establishing a heavy lift launch capability by 1998.²

RECOMMENDATION 6

Initiate a nuclear thermal rocket technology development program.

The Synthesis Group has determined the only prudent propulsion system for Mars transit is the nuclear thermal rocket. Sufficient testing and care must be taken to meet safety and environmental requirements.

RECOMMENDATION 7

Initiate a space nuclear power technology development program based on the Space Exploration Initiative requirements.

The program must concentrate on safe, reliable systems to a megawatt or greater level. These nuclear power systems will be required for use on the Moon before use on the Mars mission.

RECOMMENDATION 8

Conduct focused life sciences experiments.

Implement a definitive life sciences program, along with the necessary experiments and equipment, on Space Station Freedom, consistent with the recommendation of the Advisory Committee on the Future of the U.S. Space Program. These experiments are needed to reduce the uncertainties of long duration space missions.²

RECOMMENDATION 9

Establish education as a principal theme of the Space Exploration Initiative.

The Initiative will require scientists, engineers and technicians for its execution. It is a source of interest and expectation to those considering science and engineering careers. The Space Exploration Initiative can con-

tribute directly to undergraduate and graduate education in engineering and science by re-invigorating a university research program in support of the Exploration Initiative as was done during the Apollo program of the 1960s and early 1970s.

RECOMMENDATION 10

Continue and expand the Outreach Program.

The Outreach Program has served a very useful purpose in the Synthesis Group’s deliberations. The ideas from the Outreach Program will be turned over to NASA with the recommendation that they review them periodically. The Outreach Program generated not only ideas but also greater interest in the Space Exploration Initiative. Both features should be emphasized. The database should be refreshed with further outreach solicitations, perhaps every two years, and with increasing focus to specific program goals. The Space Exploration Initiative touches virtually every scientific field and engineering discipline. The Outreach Program should be extended to include all other entities that are affected by the program in addition to the aerospace industry. An informed public is vital to the Space Exploration Initiative, which will require a sustained commitment of the nation’s resources.

¹ The Advisory Committee on the Future of the U.S. Space Program.

² These recommendations are consistent with and expand upon those made by the Advisory Committee on the Future of the U.S. Space Program.

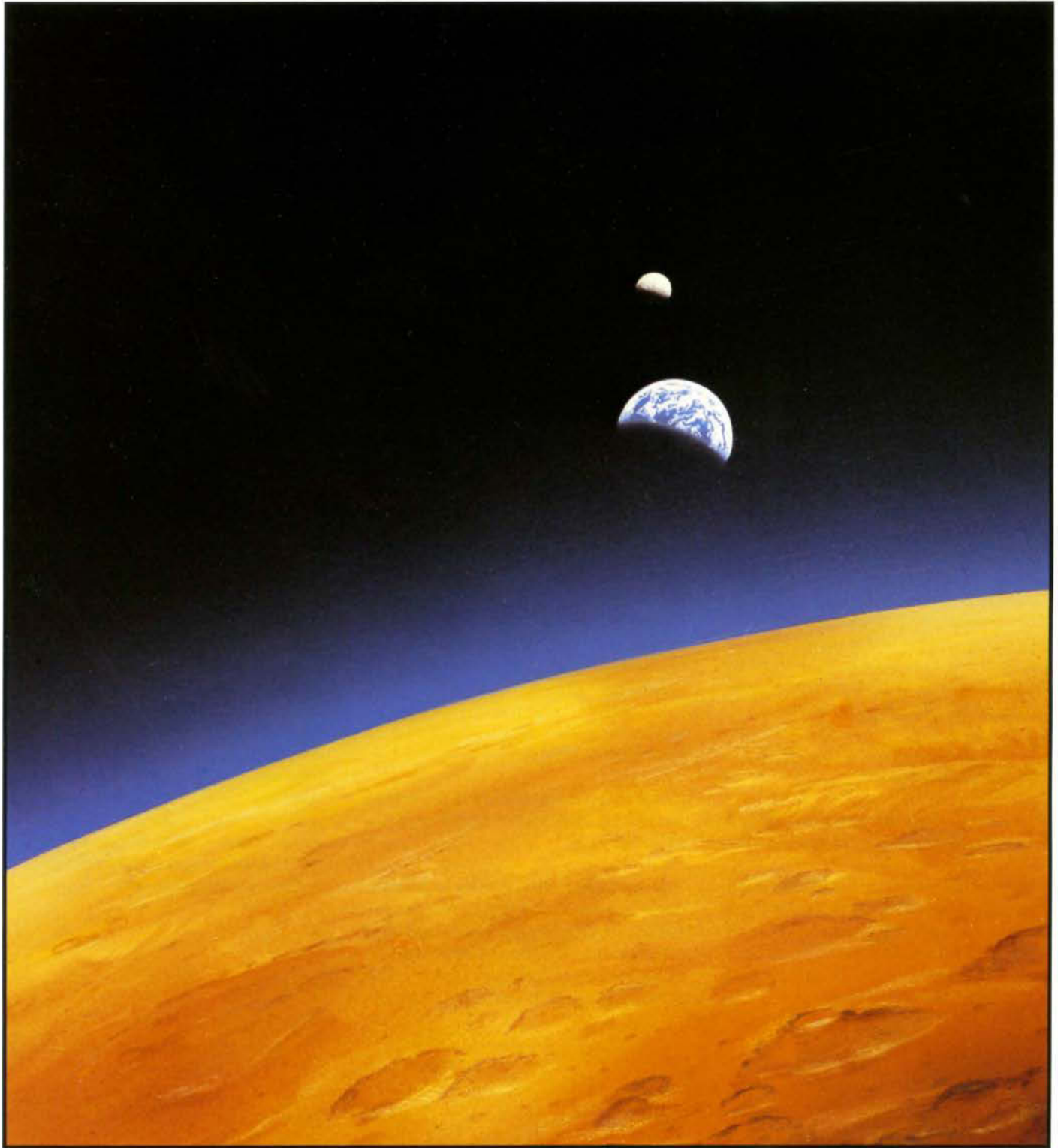

An Opportunity for the New Century

MEMBERSHIPA - 2

LEGACIES.....A - 8

WAYPOINTS INTRODUCTIONA - 9

 LUNAR EXPLORATION.....A-10

 PREPARATION FOR MARS.....A-15

 HABITATION.....A-20

 LUNAR BASED OBSERVATIONA-23

 FUELSA-28

 ENERGY TO EARTHA-32

 ASTEROIDSA-37

 MARSA-39

THE OUTREACH PROCESS.....A-44

 OUTREACH PARTICIPANTSA-50

 OUTREACH PRESENTATIONSA-53

GLOSSARY.....A-59

BIBLIOGRAPHYA-61

ART ACKNOWLEDGEMENTSA-67

Steering Committee

Thomas P. Stafford, Chairman

Thomas P. Stafford, Lieutenant General, U.S. Air Force (Ret.), is the Chairman of the Synthesis Group.

General Stafford has served as an advisor to a number of governmental agencies including the National Aeronautics and Space Administration and the Air Force Systems Command. He was a defense advisor to Ronald Reagan during the presidential campaign and a member of the Reagan transition team. He presently serves on the National Research Council's Aeronautics and Space Engineering Board and the Committee on NASA Scientific and Technological Program Reviews.

Upon graduation from the U.S. Naval Academy in 1952, General Stafford entered the Air Force, serving initially as a fighter pilot. He attended the USAF Experimental Flight Test School in 1958 and was selected as an astronaut in 1962.

He piloted Gemini VI in 1965 and commanded Gemini IX in 1966. In 1969, he was named Chief of the Astronaut Office and became the Apollo X commander for the first lunar module flight to the moon. He commanded the Apollo-Soyuz Test Project in 1975, which culminated in the first meeting in space between American astronauts and Soviet cosmonauts.

Subsequently, he served as commander of the Air Force Flight Test Center at Edwards Air Force Base and then as USAF Deputy Chief of Staff for Research, Development and Acquisition.

General Stafford has over 500 hours in space and over 7,500 flying hours. He has flown 125 different types of aircraft and four spacecraft. He received the Harmon International Aviation Trophy twice. His awards include the Presidential Medal of Freedom, two NASA Distinguished Service Medals, two NASA Exceptional Service Medals, the American

Institute of Aeronautics and Astronautics Chanute Flight Award, the Veterans of Foreign Wars National Space Award, the National Geographic Internationale Gold Space Medal, and the National Academy of Television Arts and Sciences Special Trustee Award. Among his military decorations are three Air Force Distinguished Service Medals. He achieved the fastest speed ever recorded during the Apollo X re-entry. General Stafford has received a number of honorary degrees.

Robert C. Seamans, Vice Chairman

Dr. Seamans is a Senior Lecturer in the Massachusetts Institute of Technology Department of Aeronautics and Astronautics. He is a graduate of Harvard (B.S., 1940) and the Massachusetts Institute of Technology (M.S., 1942; Doctor of Science, 1951). He has served as Dean of Engineering and as a professor of Environment and Public Policy at Massachusetts Institute of Technology. Dr. Seamans has served in several governmental positions of great importance. He was NASA Associate Administrator (1960-1965), Deputy Administrator (1965-1968), Secretary of the Air Force (1969-1973), and the Energy Research and Development Administrator (1974-1977). During 1973-1974, he also served as President of the National Academy of Engineering. He is a member of numerous boards and professional societies. Among his many honors and awards are the NASA Distinguished Service Medal, the Goddard Trophy, Department of Defense Distinguished Public Service Medal, and the USAF Thomas D. White National Defense Award.

George W. S. Abbey, Deputy for Operations

After receiving a B.S. degree from the U.S. Naval Academy, Mr. Abbey was commissioned in the U.S. Air Force. A pilot with over 4,000 flying hours,

Mr. Abbey received an M.S. in electrical engineering from the Air Force Institute of Technology. He has had a distinguished career of federal service with the Air Force and the National Aeronautics and Space Administration. He served in assignments of increasing responsibility on major space efforts: the Air Force Dyna-Soar program, the Apollo Spacecraft program, and the Skylab, Apollo-Soyuz and Space Shuttle programs. His career at the Johnson Space Center included service as the Director of Flight Operations for the Space Shuttle flight test program and as the Director of Flight Crew Operations. He was responsible for astronaut and flight crew selection and flight crew training. He has most recently served as the Deputy Associate Administrator of the Office of Space Flight at NASA Headquarters. He is a member of a number of professional societies and is the recipient of many honors and awards, including two NASA Distinguished Service Medals, the NASA Exceptional Service Medal, the Presidential Medal of Freedom and the American Astronautical Society Space Flight Award.

Spence M. Armstrong, Director of Program Architecture

Lieutenant General Armstrong retired from the U.S. Air Force in April 1990, after almost 34 years of service. His last active duty position was Vice Commander, Air Force Systems Command. Just prior to that, he served as Vice Commander-in-Chief of the Military Airlift Command. Command positions held include Chief of the Joint U.S. Military Training Mission to Saudi Arabia, Air Force Military Training Center at Lackland Air Force Base, Texas, and the 80th Flying Training Wing. He is a test pilot who was an instructor at the Test Pilot School for three years. His combat experience included 100 missions over North Vietnam in the F-105 in 1967-68. General Armstrong is a U.S. Naval Academy graduate

with a masters degree in astronautical engineering and instrumentation from the University of Michigan.

John L. McLucas

Dr. McLucas has a distinguished record of public and private service. He has served as Secretary and Undersecretary of the Air Force, Federal Aviation Administration Administrator, Deputy Director of Defense Research and Engineering, and Assistant Secretary General of the North Atlantic Treaty Organization for Science. He has served as Chairman of the NASA Advisory Council and the Air Force Studies Board and as a member of the Defense Science Board and the Air Force Scientific Advisory Board. In the private sector, Dr. McLucas has been Vice President and President of HRB-Singer, President of MITRE, Executive Vice President of COMSAT, and President of COMSAT General and COMSAT World Systems. He is a member of many corporate boards. He has received many professional honors, including the American Institute of Aeronautics and Astronautics Reed and Goddard awards. He is a member of the Council of the National Academy of Engineering.

Leon T. Silver

Dr. Silver is a professor of Resource Geology at California Institute of Technology. Following service with the U.S. Navy, Dr. Silver has divided his professional efforts between the U.S. Geological Survey and California Institute of Technology. He has performed extensive research in many facets of geology. He is a member of the National Academy of Sciences, the National Research Council Governing Board and the American Academy of Arts and Sciences. Dr. Silver has served as a Member and Chairman of the Department of Energy Science Advisory Council, President of the Geological Society of America and is a recipient of many

awards and commendations for professional excellence. He played a major role in instructing and training the Apollo astronauts in lunar geology and exploration.

Senior Members

James A. Abrahamson

Lieutenant General Abrahamson, USAF (Ret.), is the Executive Vice President for Corporate Development of the Hughes Aircraft Company. After a 33-year Air Force career, he retired in 1989 while serving as the first Strategic Defense Initiative director, where he provided policy direction and supervised key research and development programs and the acquisition process. Prior to that, he served as Associate Administrator for NASA's Space Transportation System and was responsible for the Space Shuttle program. He also directed the F-16 consortium for the North Atlantic Treaty Organization co-production of this aircraft. He is a Massachusetts Institute of Technology graduate with a B.S. in aeronautical engineering and an M.S. in the same field from the University of Oklahoma. He was the 1986 recipient of the Goddard Trophy.

Edward C. "Pete" Aldridge, Jr.

Mr. Aldridge is currently President, McDonnell Douglas Electronic Systems Company, in McLean, Virginia. Prior to this position, Mr. Aldridge was Secretary of the Air Force from 1986-1988. He joined the Reagan Administration in 1981 as the Undersecretary of the Air Force. One of his key responsibilities was coordinating the Air Force and national security space activities. He has held numerous management positions in government (Office of the Secretary of Defense, Office of Management and Budget) and the aerospace industry (System Planning Corporation, LTV Corporation and Douglas Aircraft Company). Mr. Aldridge was an advisor on the Strategic Arms

Limitation Talks in 1970-1972. He holds a B.S. degree in aeronautical engineering from Texas A&M University and an M.S. degree in aeronautical engineering from the Georgia Institute of Technology.

David C. Black

Dr. Black received a Ph.D. in physics from the University of Minnesota. He is currently Director of the Lunar and Planetary Institute. He is a recognized authority in the search for and study of other planetary systems. His career includes service as Chief of the Theoretical Studies Branch, Chairman of the Basic Research Council, Chief Scientist for Space Research at NASA Ames Research Center and NASA Chief Scientist for Space Station. He has accomplished pioneering experimental research in theoretical astrophysics and planetary science.

Eugene E. Covert

After receiving B.S. and M.S. degrees at the University of Minnesota, Dr. Covert received his doctorate from the Massachusetts Institute of Technology in 1958. He has had a continuing association with the Massachusetts Institute of Technology Department of Aeronautics and Astronautics as a professor and head of the department. He has served as the Chief Scientist of the Air Force, Director of the European Office of Research and Development, member and Chairman of the Air Force Scientific Advisory Board and a member of the Presidential Commission on the Space Shuttle Challenger Accident. He serves on the boards of several corporations. He is a member of the National Academy of Engineering, the Royal Aeronautical Society, the New York Academy of Science and the American Association for the Advancement of Science. Dr. Covert is the recipient of many honors, including the Air Force Exceptional Civilian Service Award, the NASA Public Service Award and the Von Karman Medal.

Donald L. Cromer

Lieutenant General Cromer, a 1959 U.S. Naval Academy graduate, was commissioned in the Air Force. He served in a series of missile organizations and space-related assignments. In 1986, he became the Commander of the Space and Missile Test Organization at Vandenberg Air Force Base. He was responsible for the management of test, launch and on-orbit control activities of Air Force space and ballistic missile systems. He was also responsible for Western and Eastern Space and Missile Centers and the Consolidated Space Test Center at Onizuka Air Force Base. Lieutenant General Cromer became commander of the Space Systems Division, Air Force Systems Command in June 1988. He wears the Master Missile and Master Space badges. Among his military decorations are the Distinguished Service Medal and the Legion of Merit with oak leaf cluster.

Maxime A. Faget

Dr. Faget is the Chief Executive Officer of Space Industries, Inc., and is involved with the design and development of industrial space facilities. During a 35-year career with NACA and NASA, Dr. Faget served in engineering and managerial positions in manned spacecraft programs. He conceived the Project Mercury one-man spacecraft and Gemini and Apollo configurations and the design of a completely reusable spacecraft that led to the Space Shuttle. Dr. Faget is an author, the holder of many space-related patents and the recipient of many awards and honors, including the American Society of Mechanical Engineers Gold Medal and two NASA Distinguished Service Awards. He is a member of the National Space Hall of Fame.

Joseph G. Gavin, Jr.

Mr. Gavin is a Senior Management Consultant for Grumman Corporation. Previously he served as

President and Chairman of the Executive Committee of Grumman. Earlier, he was Chief of the Grumman Missile and Space Engineering Program and Director of the Apollo Lunar Module Program, for which he received the NASA Distinguished Public Service Medal. He was the Aerospace Educational Council "Man of the Year" in 1968. He is a member of the National Academy of Engineering, the American Astronautical Society and the American Association for the Advancement of Science.

Michael D. Griffin

Dr. Griffin is the Deputy for Technology of the Strategic Defense Initiative Organization. He holds six degrees in physics, electrical engineering, aerospace engineering and business administration from Johns Hopkins University, Catholic University, the University of Maryland, the University of Southern California and Loyola College of Maryland. He has worked in spacecraft design and mission operations at Computer Sciences Corporation, Jet Propulsion Laboratory, Johns Hopkins Applied Physics Laboratory and the Strategic Defense Initiative Organization. He is a recipient of the Department of Defense Distinguished Public Service Award and the American Institute of Aeronautics and Astronautics Space Systems Award for his work on the Strategic Defense Initiative Organization Delta 180 space intercept mission. Dr. Griffin has been an adjunct professor at the University of Maryland, Johns Hopkins University and George Washington University, offering courses in astrodynamics, spacecraft design and applied mathematics. He is a registered professional engineer in Maryland and California and the co-author, with J. R. French, of the textbook *Space Vehicle Design*.

Larry B. Grimes, Esquire

Mr. Grimes is partner in charge of the McGuire, Woods, Battle, and Boothe

law office in Washington, D.C. His areas of specialization are corporate legal matters and commercial and international financial transactions. Following experience with the Securities and Exchange Commission and with Westinghouse Electric Corporation, Mr. Grimes has, since 1981, devoted himself to the private practice of law. He represents major high-technology companies in the United States and abroad. He has represented joint ventures with particular emphasis on structuring non-conventional finance (commodities countertrade) transactions for export of high technology goods to the developing world. Mr. Grimes attended the University of Idaho (B.A. 1965, J.D. 1967) where he was editor of the Idaho Law Review.

Henry J. Hatch

Lieutenant General Hatch, U. S. Army Corps of Engineers, is a 1957 graduate of the U.S. Military Academy. He also holds an M.S. in geodetic science from Ohio State. He is a graduate of the Army Command and General Staff College and the Army War College. Through a variety of significant command and staff assignments, Lieutenant General Hatch rose to the command of the U.S. Army Corps of Engineers in 1988. He has served in Korea, Vietnam and Europe. He also served on the faculty at the U.S. Military Academy. He has earned the Ranger, Master Parachutist and Army Air Assault Badges. Among his military decorations are the Distinguished Service Medal and the Legion of Merit.

Bastian "Buz" Hello

A 1948 mechanical aeronautical engineering graduate of the University of Maryland, Mr. Hello retired in 1988 as the Corporate Senior Vice President of Rockwell International Corporation. His industry experience spans the P-5M Patrol Seaplane; the Air Force Prime Lifting Body; Saturn-Apollo launch operations; the Space Shuttle; B-1 research, development

and test; and corporate relations with all branches of the federal government. He is a member of several U.S. political and international professional associations and is a past president of the American Institute of Aeronautics and Astronautics. He is the recipient of numerous honors, two NASA Public Service Awards and the NASA Distinguished Public Service Award.

George W. Jeffs

Mr. Jeffs received B.S. and M.S. degrees in aeronautical engineering from the University of Washington and is a veteran of 44 years service with Rockwell International. His duties have involved many key space efforts: Apollo Chief Engineer; NAVSTAR Global Positioning System; research, development and production of high performance aircraft and all aspects of the Space Shuttle system (integration and operations, orbiter and main engine development); and several advanced surveillance, communications and technology programs. He is a member of several professional associations and the recipient of many honors, including membership in the National Academy of Engineering, two NASA Distinguished Service Medals and the Presidential Medal of Freedom.

Christopher C. Kraft, Jr.

From 1945 until 1982, Mr. Kraft had a distinguished career in government. While with NASA, he made significant contributions to aeronautical flight research. He was the Johnson Space Center Director for ten years. He was a member of the original Space Task Group established to manage Project Mercury. He was a prime contributor to the development of many basic mission and flight control techniques for manned space flight. He was Flight Director of all Mercury missions and many Gemini missions. He directed the design and implementation of the Mission

Control Center in Houston. He is the recipient of many honors and awards, including the Presidential NASA Outstanding Leadership Medal and four NASA Distinguished Service Medals.

Thomas S. Moorman, Jr.

Lieutenant General Moorman is the Commander of the Air Force Space Command. A graduate of Dartmouth College, he was commissioned through the Reserve Officer Training Corps program as a distinguished graduate in 1962. He served in assignments of increased responsibility in the intelligence and space fields. In October 1987, Lieutenant General Moorman became Director of Space and Strategic Defense Initiative Programs, Office of the Assistant Secretary of the Air Force for Acquisition. He also represented the Air Force in the Strategic Defense Initiative program and served as special assistant for the Strategic Defense Initiative to the Vice Commander for Air Force Systems Command. The Distinguished Service Medal and the Legion of Merit with Oak Leaf Cluster are among his military decorations.

Charles A. Ordahl

Mr. Ordahl is Vice President of McDonnell Douglas Space Systems Company. An electrical engineer from the University of North Dakota, he has held numerous executive positions related to space. He has extensive experience in commercial launch endeavors both in the United States and abroad. With McDonnell Douglas, his responsibilities have encompassed Space Transportation, Space Station and now the Space Exploration Initiative. He is a member of many professional associations.

Bernard A. Schriever

General Schriever retired from the Air Force in 1966 after 33 years of service. After a distinguished wartime career, he was assigned many scientific duties. He received a B.S. degree

from Texas A&M in 1931 and a M.A. degree in aeronautical engineering from Stanford in 1942. After the war, he was Chief of the Scientific Liaison Section, Headquarters USAF. He commanded the Air Force Ballistic Missile Division and the Air Research and Development Command. He was responsible for research and development on Atlas, Titan, Thor and Minuteman ballistic missiles. Concurrently, he provided launch sites, tracking facilities and ground support equipment necessary for deployment. Since his retirement, General Schriever has been a consultant to government and industry on technology and management. He has served on numerous commissions and received many awards, including the 1980 induction into the Aviation Hall of Fame and the 1986 Forrestal Award.

Joseph F. Shea

A retired Senior Vice President of the Raytheon Company, Dr. Shea is an adjunct professor of Aeronautics and Astronautics at the Massachusetts Institute of Technology. His academic and industry experience include many engineering and space accomplishments. Among his contributions in the field of spaceflight were service as NASA Deputy Director of Manned Space Flight and Apollo Program Manager. He also served as the General Motors manager of the Titan Inertial Guidance program. He has served on the NASA Advisory Council, the Defense Science Board and the National Research Council. He is a member of the National Academy of Engineering and is President of the American Institute of Aeronautics and Astronautics.

H. David Short, III

Dr. Short received his B.S. in chemistry from Emory University and his medical degree from Baylor College of Medicine. He is responsible for the re-initiation of the heart and lung transplant program at the Texas

Medical Center. He was extensively involved in the laboratory research and clinical application of total artificial heart and heart assist programs at Texas Medical Center. He also served as a key surgeon on Dr. DeBakey's heart transplant team. He has extensive surgical experience in heart, heart-lung and heart-lung and kidney transplants. Society memberships include Phi Beta Kappa, Omicron Delta Kappa, The American Medical Association, the International Society for Heart Transplantation, and the Michael DeBakey International Surgical Society. He is a professor of surgery at Baylor College of Medicine and has been recognized for his many contributions as an author, with over two dozen books and articles published. He is also a noted panelist in his chosen fields.

H. Guyford Stever

Dr. Stever, a physicist, has a record of significant service in both the public and private sectors. In academia, Dr. Stever has been the President of Carnegie-Mellon University, the head of the Massachusetts Institute of Technology Department of Mechanical Engineering, Naval Architecture and Marine Engineering. In government service, he has been Director of the National Science Foundation, Science Advisor to President Nixon and President Ford and the Air Force Chief Scientist. During World War II, Dr. Stever taught and conducted radar research at the Massachusetts Institute of Technology Radiation Laboratory, a contribution that was recognized by the President's Certificate of Merit. In the private sector, Dr. Stever has served as the director of several national corporations. He is a member of the National Academy of Sciences, the National Academy of Engineering and national and foreign professional societies.

James R. Thompson, Jr.

J. R. Thompson has been the Deputy Administrator of NASA since July

1989. A native of Greenville, S.C., he graduated from Georgia Institute of Technology (bachelor's degree in aeronautical engineering, 1958) and the University of Florida (master's degree in mechanical engineering, 1963). He has completed all course work toward a Ph.D. in fluid mechanics at the University of Alabama. Among his previous assignments are: Manager of the Space Shuttle Main Engine Project; Vice Chairman of NASA Task Force on the Challenger Accident; Deputy Director for technical operations at Princeton's Plasma Physics Laboratory; and head of Marshall Space Flight Center (1986-1989). He received the NASA Medal for Exceptional Service in 1973 and the NASA Medal for Distinguished Service in 1981 and 1988. He was one of the recipients of the Goddard Memorial Trophy in 1989.

John F. Yardley

Mr. Yardley has spent his entire career in aerospace, starting with his graduation from Iowa State University in 1944 as an aeronautical engineer. He went to McDonnell Aircraft in 1946 and worked on fighter airplanes until 1958, when he became the McDonnell Aircraft Chief Engineer for the Mercury Spacecraft Design, their Mercury Launch Manager and then the Gemini Technical Director. He became NASA's Associate Administrator for Manned Space Flight during Space Shuttle development. He returned to McDonnell Douglas in 1981 as President of the McDonnell Douglas Astronautics Company. Mr. Yardley retired in 1989. He is a member of the National Academy of Engineering, a Fellow of the American Institute of Aeronautics and Astronautics and the American Astronautical Society, and has received numerous awards, including the Goddard Space Trophy, the Spirit of St. Louis Medal and the Von Karman lectureship.

Synthesis Group Membership

Bruce A. Abbott, Lieutenant Commander, USN, Naval Space Command

Judi K. Abbott, Administrative Support

Charles E. Anderson, Colonel, USAF, Office of the Secretary of the Air Force Space Systems

Katherine J. Ball, Administrative Support

Dave Bartine, Ph.D., Oak Ridge National Laboratory

J. Douglas Beason, Ph.D., Major, USAF, Phillips Laboratory

Kirk M. Bergner, Major, USA, Corps of Engineers

Jeff M. Bingham, NASA Headquarters

David Buden, Idaho National Engineering Laboratory

Richard J. Burick, Ph.D., Los Alamos National Laboratory

Constance J. Carté, Lieutenant Commander, USN, Naval Air Systems Command

Douglas R. Cooke, NASA Johnson Space Center

Kathryn A. Cronk, Administrative Support

George L. J. Dalferes, J.D., Colonel, USAF (Ret.), Martin Marietta Corporation

Richard W. Davis, Colonel, USAF, Phillips Laboratory

James E. Ford, Lieutenant Colonel, USAF, Office of the Secretary of the Air Force Acquisition

Joe G. Foreman, Ph.D., Naval Research Laboratory

Sanjay Ghosh, Computer Support

Beverly R. Hamilton, Computer Support

Steven D. Harrison, Ph.D., Lieutenant Colonel, USA, Strategic Defense Initiative Office

Kerry Joels, Ph.D., Department of Health & Human Services
Debra M. Ladwig, Computer Support
Randy J. Lavigne, Captain, USAF, Phillips Laboratory
Deborah A. Lazerson, Naval Air Systems Command
David J. Lee, Lieutenant Colonel, USMC, Space Systems
Deidre A. Lee, NASA, Johnson Space Center
Roger Lenard, Lieutenant Colonel, USAF, Strategic Defense Initiative Office
Gregg Linebaugh, ST Systems Corporation
Catherine A. Lumley, Administrative Support
Michael I. Mott, Lieutenant Colonel, USMC
James R. Nise, Cubic Defense Systems
Stewart D. Nozette, Ph.D., Lawrence Livermore National Laboratory
Mary F. Nugent, Office of the Secretary of Defense, Legislative Affairs
Donald R. Pettit, Ph.D., Los Alamos National Laboratory
Donald Rea, Ph.D., NASA, Jet Propulsion Laboratory
Allison C. Sandlin, Ph.D., National Institute of Standards and Technology
C. Randall Seftas, Lockheed Missiles and Space Company
Don Segna, Department of Energy, Richland Operations Office
Paul D. Spudis, Ph.D., Lunar and Planetary Institute
Siegfried R. Stief, Captain, USAF, Office of the Secretary of the Air Force Space Systems
Donald F. Stewart, M.D., NASA Headquarters
Lawrence C. Trost, Sandia National Laboratories

George H. Ulrich, Rockwell International
Judith A. Wildman, Administrative Support
Catherine A. Williams, Administrative Support
Richard J. Wisniewski, NASA Headquarters

Technical Advisors

James C. Adamson, Colonel, USA, NASA, Johnson Space Center, Astronaut
Delane Aguilar, Office of Secretary of the Air Force, Financial Management
Kent Biringer, Sandia National Laboratories
Steve Book, The Aerospace Corporation
M. L. "Sonny" Carter, Captain, USN, NASA, Johnson Space Center, Astronaut
Norman Chaffee, NASA, Johnson Space Center
Alan B. Chinchar, Consultant
Dan Clough, NASA, Headquarters
Kelley Cyr, NASA, Johnson Space Center
Laura Danly, Ph.D., Space Telescope Science Institute
Brett Drake, NASA, Johnson Space Center
Lisa Guerra, NASA, Johnson Space Center
Frederick H. Hauck, Captain, USN (Ret.), Astronaut
Steven A. Hawley, Ph.D., NASA, Ames Research Center, Astronaut
Francis T. Hoban, NASA Headquarters
Carolyn L. Huntoon, Ph.D., NASA, Johnson Space Center
Roderick Hyde, Ph.D., Lawrence Livermore National Laboratories
Kent Joosten, NASA, Johnson Space Center
Albin Kazanowski, The Aerospace Corporation

Alan Ladwig, Consultant
Edgar C. Lineberry, Jr., NASA, Johnson Space Center
George D. Nelson, Ph.D., University of Washington, Astronaut
John O'Neill, NASA, Johnson Space Center
Arnauld E. Nicogossian, M.D., NASA, Headquarters
Donna Pivrotto, Ph.D., NASA, Jet Propulsion Laboratory
Steve E. Potts, Professional Services International, Inc.
James W. Purvis, Ph.D., Sandia National Laboratories
William Shepherd, Captain, USN, NASA, Johnson Space Center, Astronaut
Christina Voss, Captain, USAF, Space Systems Division
Brenda Ward, Ph.D., NASA, Johnson Space Center
Thomas E. Ward, Ph.D., Brookhaven National Laboratory
David B. Weaver, NASA, Johnson Space Center
Robert Wharton, Ph.D., Desert Research Institute
H. William Wood, Bendix Field Engineering Corporation
John Young, Captain, USN (Ret.), NASA, Johnson Space Center, Astronaut

Documentation Support: TADCORPS:

John W. Albino
Karla J. Bowers
Barbara G. Campbell
M. Gary Clemmons
Marcia L. Hargreaves
Belinda W. K. Lai
William M. Lawbaugh, Ph.D.
Dayle A. Thompson
Rodney E. Warren

LEGACIES

In order to provide guidance for developing architectures, a list of guidelines was developed based upon the programmatic experience of the senior members of the Synthesis Group acquired since the space program's inception. This list of Space Experience Legacies was presented to the Advisory Committee on the Future of the U.S. Space Program and was well received by the committee.

Space Experience Legacies

Guidelines

- 1) Establish crew safety as the number one priority.
- 2) Have clean lines of management authority and responsibility for all elements of the program — ensure that one organization or prime contractor is clearly in charge.
- 3) Establish realistic program milestones that provide clear entry and exit criteria for the decision process, and create useful capabilities at each step.
- 4) Ensure that the Administration and the Congress clearly understand the technical and programmatic risks and realistic costs of the Space Exploration Initiative.
- 5) Mandate simple interfaces between subsystems and modules.
- 6) Make maximum use of modularity over the life of the program to maintain flexibility. Successive missions should build on the capabilities established by prior ones. Provide the capability to incorporate new technology as required.
- 7) Press the state-of-the-art in technology when required and/or when technological opportunities are promising with acceptable risk.
- 8) Ensure optimum use of man-in-the-loop. Don't burden man if a machine can do it as well or better, and vice versa.
- 9) Limit development times to no more than ten years. If it takes longer, the cost goes up and commitment goes down.
- 10) Focus technology development toward programmatic needs.
- 11) Minimize or eliminate on-orbit assembly requiring extravehicular activity.
- 12) Minimize mass to low Earth orbit to reduce cost.
- 13) Have redundant primary and separate backup systems. Design in redundancy versus heavy reliance on onboard/on-site maintenance.
- 14) Hire good people, then trust them.

Pitfalls

- 1) Establishing requirements that you will be sorry for; i.e., wish lists being treated as requirements and allowing requirements to creep.
- 2) Trying to achieve a constituency by promising too much to too many and "low balling" the technical and financial risks.
- 3) Committing to interminable studies and technology demonstrations without a firm commitment to execute a real program.
- 4) Not establishing configuration controls/baselines as soon as possible; e.g., weight and electrical power requirements.
- 5) Allowing software to run unchecked and become a program constraint rather than a supporting element.
- 6) Setting up agreements for development of program elements that are not under direct program management control.
- 7) Not saying "we were wrong" when we were wrong.

There are desired activities that can be accomplished on planetary surfaces and a number of ways to implement those activities. To follow a logical pattern for the presentation of a diverse set of architectures, the Synthesis Group concentrated on the major topical activities to be performed on the planetary surfaces prior to defining the transportation system to reach those surfaces. Areas of planetary activity are referred to as waypoints, and are further defined by incremental degrees of capability. Each degree of capability is a significant achievement.

The waypoints are structured to provide a series of building blocks for the development of architectures. An architecture is a set of activities encompassing parts of several waypoints.

As the Synthesis Group developed the waypoints, terminology to define the activities was established, based on achieving levels of operational capability. The achievement of the first operational capability is defined as the Initial Operational Capability.

Subsequent activity levels that significantly provide increased capabilities are defined as the Next Operational Capability. Achieving a Full Operational Capability is the ultimate level of activity envisioned. It is important to note that achieving the Full Operational Capability does not mean the activities for any particular waypoint are complete, but are rather achieving a steady level.

The Moon is a fairly well-known environment because of its proximity to Earth and the experience gained from accomplishing six very successful lunar landings. The waypoints, therefore, emphasize lunar activities. The activities on the Moon provide a firm basis of experience to provide and plan confidently for a broader range of activities. Mars, however, is a more remote and lesser known environment. Consequently, the initial activities on Mars will be exploration, to gain the necessary knowledge and understanding for further activities.

Waypoints

Moon Waypoints

- Lunar Exploration
- Preparation for Mars
- Habitation
- Lunar Based Observation
- Fuels
- Energy to Earth

Asteroids Waypoint

Mars Waypoint

The Exploration Waypoint starts with the exploration of the Moon as a planetary body by performing planetary geoscience, characterizing resources, making maps, characterizing the environment and evaluating human performance.

Waypoint Objective

The Moon is a small planetary body of surprising complexity. Unlike the Earth, it possesses a detailed, somewhat undisturbed record of its early history and evolution. Since the Moon is less geologically active than the Earth, it offers us a valuable record of the rate of meteoric impact bombardment in the Earth-Moon system and of the level of output of the Sun for the past four billion years.

The Moon is a potential future workplace for humans beyond low Earth orbit. As such, we need to understand the origin and evolution of the Moon as completely as possible. Moreover, inventory and characterization of the resources on the Moon are required to utilize lunar materials fully for human benefit and long term exploration.

The objective of this waypoint is to provide an increasing capability to explore the Moon, at ever greater levels of detail, at a number of sites, over a substantial period of time. To do this, there is a desire for additional strategic knowledge of the Moon before humans return to it. After temporary human visits, a permanent or semi-permanent human presence would be established. This phased build-up permits intelligent decisions

to be made regarding exploration plans as the program goes forward.

Another important aspect of the waypoint construction is the capacity for real time modification of exploration in response to new discoveries or changing conditions and requirements. From a purely scientific perspective, lunar exploration provides an important window into the history and processes of our Solar System.

Widespread dissemination of the knowledge produced through exploration will be an integral part of the waypoint construction. Techniques and interfaces have been included to significantly enhance the educational return from this waypoint's activities. Such return is manifested not only through traditional interfaces (e.g., schools and universities), but also through telecommunications technology

LUNAR EXPLORATION

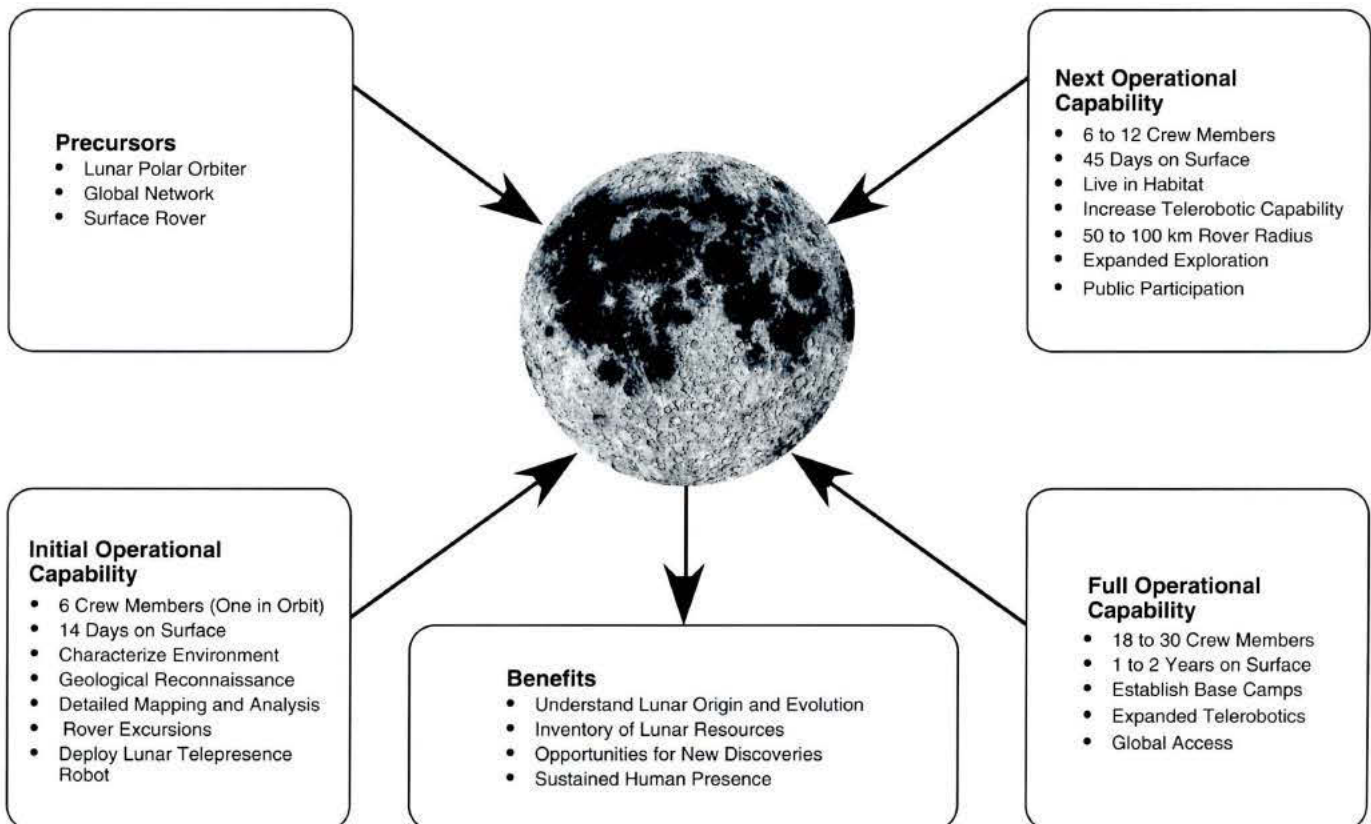

gies (e.g., high-definition television) that permit the general public to share directly in the exploration experience.

Discussion

Mission definition is crucial in implementing the Lunar Exploration Waypoint. The issue is whether to establish a fixed outpost, gradually building up to a permanent base, or to conduct separate, multiple missions to different sites. Each option has specific advantages: a fixed outpost rapidly builds up infrastructure while multiple sites greatly increase the scientific return of the waypoint. If the primary reason for going to the Moon is exploration, then multiple sites might be preferred. However, in combination with other equally emphasized activities, a fixed outpost might be more attractive.

Extended access to multiple sites is a key requirement in conducting surface exploration. This is best accomplished by a crew using a pressurized rover. The pressurized rover is an essential part of geologic exploration and provides a means of traveling to distant sites but also exploring while traversing the terrain. Surprising and significant discoveries could be made in this way.

“Telepresence” robots can conduct some geologic field work. While such a technique might greatly enhance the scientific return, the details of how such robots might work with people remain to be developed. Operators for these telepresence robots need near-instant radio contact with the robots. This may be marginally obtainable by having the controllers on the Earth, but operators on or near the Moon have a near-zero time lag for robotic teleoperations. An operator located at an Earth/Moon Lagrange point (L1), for example, would have complete line-of-sight radio access to almost the entire near side of the Moon. Teleoperations from this vantage accomplish significant field exploration by projecting

human powers of thought and observation into the robotic alter ego on the surface. This operations concept is particularly valuable at Mars, where telerobotic control from Earth is not feasible because of the great time lag in radio communications. Although the robots advocated here are extremely capable, people still maintain an edge as explorers, probably for the indefinite future.

Initial Operational Capability

The Initial Operational Capability is substantial, designed to build on the unique scientific opportunities provided by an optimum mix of robotic and human presence, each supporting the other. The waypoint can be implemented in several ways, each of which provides specific exploration advantages. A crew of six returns to the Moon. Five crew members descend to the surface and explore a carefully selected site during one lunar daytime (14 Earth days), with the sixth crew member remaining in orbit. During initial missions, crew members live out of the lander, which keeps the total delivered mass to the lunar surface small at the Initial Operational Capability. These missions explore the immediate vicinity of the selected site, returning samples, observations and data on the site geology, resources and physical environment. Surface activities include geologic surface reconnaissance and field work, instrument package emplacement, detailed mapping and initial data analysis. Mission success depends largely on the ability to do effective, long-duration extravehicular activity. Based on experience, a low pressure (~5 psi), reliable, redundant, rugged and flexible extravehicular activity suit is required. The extravehicular activity suit should have no prebreathe requirement.

On the initial missions, the crew has the ability to traverse distances of up to 50 km from the lander spacecraft in a small (~5 metric ton class)

pressurized rover; this distance increases to 100 km on subsequent flights. The pressurized rover supports a nominal crew of two (three in an emergency) for a period of up to three days, and is designed to protect the crew from solar radiation. It has an airlock, so that the entire rover is not depressurized for extravehicular activity. It has robotic manipulators, for the astronauts to collect reconnaissance samples and emplace small instrument packages enroute. And it has the ability to be teleoperated (i.e., driven) from the Earth or lander control center. This small, pressurized rover is constructed so that its capacity and traverse range can be increased incrementally on successive missions.

Flexible scheduling and mission control are key to successful surface operations. Because the task of the crew is to explore, they must have as much autonomy as possible to determine their own pace and style of investigation. Although crews work within a general exploration plan (i.e., pre-identified targets and their backups), the actual traverses and surface activities are not planned on rigid timelines, as was done during Apollo. Flexible surface operations are essential if significant discoveries are to be made and the necessary follow-up investigations carried out.

During the course of a two-week visit to the Moon, a crew of two is able to make at least three traverses in the pressurized rover. The other remaining crew members are involved in detailed field work near the lander site, with one crew member designated as the surface “mission director,” remaining in the lander and operating the telepresence robot.

A key feature of the Initial Operational Capability is pre-deployment of the lunar telepresence robot. This robot acts as a human surrogate during surface exploration, possessing much of the sensory capacity and manipulative ability of humans, including vision sensors optimized for geologic exploration. The tele-

presence robot is operated by the crew member in the lunar lander or from lunar orbit for true (no time delay) telepresence. The robot operates independently or in tandem with field crews on the Moon.

During mission operations, data rates approaching 500 Mbps are needed for short time periods. Most of this data is produced by the telepresence robot. For surface stays of two weeks, several gigabits of data are produced. As some of this data is not time-sensitive, data storage is required. In addition, a return sample mass of about 200 kg per flight has been estimated. Selective sample collection and some data analysis in the field assures that return samples are of high scientific value, equivalent to many times the samples returned by Apollo.

There are two possible ways to implement this waypoint's Initial Operational Capability. In the first case, a site is selected on the Moon that ultimately becomes the location of a permanent lunar outpost or base. The advantage of this strategy is that equipment delivered to the lunar surface becomes part of the base infrastructure. This approach rapidly expands the resource base on the Moon and the ability to support multiple crew members. A drawback is that the total exploration coverage is geographically limited, being confined by the range of the surface rover. We believe that many scientifically challenging sites exist on the Moon.

In the second approach, missions go to different sites on each flight. In this scenario, diverse targets would be chosen for specific two-week missions, with each mission carrying the same equipment complement to the Moon. A variant of this idea is to deliver one pressurized rover to the Moon for exploration. It then is remotely operated from Earth to the next site, making observations and collecting samples along the way. The rover is then available for use at

the next site, where humans refurbish and use it to conduct another mission. This kind of operation is extremely interesting scientifically because large areas of the lunar surface are explored robotically, interspersed with human field work during crew missions. The drawback of this approach is that the lunar infrastructure remains fairly small, limiting the number of people the outpost can support.

Next Operational Capability

The evolution of the Lunar Exploration Waypoint involves increasing surface access, stay times and data return. The increased data return involves not only surface science, both robotic and human, but also improved, second-generation orbital science to help understand the Moon and its resources.

For orbital science, a lunar satellite can produce global images of moderate and high resolution. These images constitute the global database needed to support future lunar cartography and surface exploration. For studying surface physical properties, specific instruments, including multispectral imaging radar, provide global maps of surface physical properties and subsurface imaging. The need also exists for regional chemical and mineralogical information, both to understand lunar processes on a gross scale and to extend the results of the detailed human field studies to larger areas.

For human surface missions, the Next Operational Capability increases surface access by increasing the range of the pressurized rover from 50 to 100 km. At those distances, great geologic diversity is available for direct field study by the crew and, through telepresence, by Earth-bound scientists and even the interested public. This increase in range can be accomplished by increasing the capacity of the pressurized rover, either as a differently designed single unit (to be delivered to the lunar sur-

face; mass ~9500 kg), or by modularly expanding the capacity of the Initial Operational Capability pressurized rover. In this second concept, power, habitation and accessory modules are connected to the Initial Operational Capability rover to comprise a multipurpose, long range surface "train." This type of vehicle is ultimately expanded to allow traverse ranges of up to 500 km and stay times of several weeks.

Crew size remains at six during the first Next Operational Capability, doubling to 12 by the second Next Operational Capability. The key feature permitting greater exploration at the first Next Operational Capability is the extension of stay time (40 Earth days) to include the lunar night. Surface illumination on the lunar near side at night from earthshine is sufficiently bright (the equivalent of a 60-watt bulb hanging from a ceiling in a dark room), that a great deal of surface exploration is possible during the lunar night, probably augmented by artificial lighting. The net effect of the increase in surface stay time is to at least double the amount of exploration time available for human field work on the Moon. The main drawback to this mode of operation is the lack of solar power available during the lunar night.

Another way to increase exploration productivity is to increase the number and capabilities of remotely operated robots on the lunar surface. Robotic rovers could perform long-range surface reconnaissance, both as a human precursor and as a way to retrieve information about distant sites that will not be visited by people. In the first case, the telepresence robot acts as a crew member, working in conjunction with the surface scientists. In the second case, separate traverses are conducted to interesting science sites that the human crew either cannot reach or does not have time to study. This mode of operation permits selected field study of sites not covered by the traverses of

the pressurized rover. It thus acts as an intermediate step between automated, robotic, geologic reconnaissance and full fledged human field study. If the robots are capable of telepresence operations (defined mostly by high-definition stereo vision and human-like manipulative abilities), then scientists on Earth and in lunar or L1 orbits actively participate in the exploration of the lunar surface, along with the crew on the Moon or independent of them.

As the capabilities for surface exploration expand, the quantities of data greatly increase. This increase probably requires augmentation of the communication and data storage facilities. Also, increased dissemination of the collected data is highly desirable. For example, it is possible to allow the general public to participate directly in the exploration of the lunar surface by transmitting the high-definition television and teleoperated robot data channels into homes (via commercial cable systems), theaters and virtual reality workstations at museums around the country. Supplying information directly to the public has great potential to interest and inform them about the ongoing exploration of the Moon.

Full Operational Capability

During Full Operational Capability, the entire Moon is available for detailed study by humans and robots. Global access for extended periods is a key requirement for understanding lunar processes and history in geoscience field study. Global access is accomplished in several ways. Separate missions from Earth orbit are staged, making the entire lunar globe continuously accessible. This mode of operation is particularly useful for multiple, temporary exploration missions of the Initial Operational Capability type.

It may ultimately be possible to traverse great distances, for weeks at a time, thus blending into a type of global surface access. This technique

is unlikely to be used in the early years, since it raises severe safety and logistical problems.

Finally, it may be that global access for humans is only achieved by telepresence. In a scenario like this, only robot field geologists physically travel around the Moon, providing human access by telepresence sensors. Although this technique of global access is likely the easiest to implement, some provision must be made for robotic return for maintenance and sample return to an outpost, base or directly to Earth.

Crews of 20 to 30 are engaged profitably in various exploration activities by Full Operational Capability. Such a large crew requires a considerable infrastructure, including multiple pressurized rovers, habitats, small utility vehicles, and robotic probes, rovers and teleoperators. A typical tour of duty is about one year. Most of the crew is stationed at the main lunar base, although several small outposts are desirable for the conduct of other lunar surface activities.

Early Milestones

The Lunar Exploration Waypoint requires precursor activities that, combined with the initial human return to the Moon, provide several early milestones. The first required lunar precursor mission is a polar-orbiting satellite carrying instruments to sense the composition and structure of the Moon. This mission should provide global maps of lunar surface chemistry, mineralogy, topography, gravity and morphology. The proposed Lunar Observer mission, if appropriately equipped, satisfies these requirements. The data from Lunar Observer is important in a strategic sense to: 1) conduct efficiently the overall global reconnaissance of the Moon required by the charter of exploration; 2) identify sites and processes deserving of more detailed investigation by either machines or people; and 3) characterize the

resources of the lunar surface for possible future exploration. A polar-orbiting mission to the Moon provides flexibility for future lunar exploration as well.

In addition to global reconnaissance from orbit, several types of surface missions have been identified. For reconnaissance, a global network of geophysical instruments would provide important information on the physical and chemical make-up of the solid Moon. At least eight stations emplaced equidistant from each other create a global network that permits clear examination of moonquake foci, determines the mean lunar heat flow to high precision, and measures local magnetic fields. Such an instrument network allows us to understand the composition and thermal characteristics of the lunar interior.

For local site studies, a surface rover deployed at a pre-designated human exploration site conducts an important "pre-reconnaissance" of the outpost site. The teleoperated rover traverses the future exploration site, making in situ chemical and mineralogic measurements, imaging the surface and subsurface, and collecting samples (to be returned to Earth later by the crew). The knowledge and samples gained provide a much more comprehensive and detailed understanding of the site than would otherwise occur, thus permitting both an expansion of exploration knowledge as well as maximizing the effectiveness of subsequent human exploration. This rover is a relatively rudimentary type of teleoperated robot (under virtually complete Earth-based control) or a much more capable telepresence robot, which is then available for use by the crew when they arrive on the Moon.

Additional precursor missions may also be undertaken, but the set described here addresses the most pressing exploration goals. All of these missions occur very early in a Space Exploration Initiative program

and constitute highly visible, scientifically productive early milestones.

Enabling Technologies and Processes

The small pressurized rover delivered at Initial Operational Capability is a key enabling technology for the Exploration Waypoint. It is envisioned that a preliminary design will incorporate an extended unpressurized rover chassis, onto which an inflatable crew module is attached. Rover pressurization is ≤ 5 psi for numerous considerations. This design permits considerable mass savings, yet still permits extended human traverses. The extended traverse range of this rover (50 km radius for the first flight with a capability to be extended up to 100 km with proper safeguards and testing) requires an advanced form of power supply; advances in rechargeable fuel cells should permit us to operate on these scales of distance.

In a similar vein, our surface activities are heavily dependent on extensive extravehicular activity and surface exploration. Reliable, redundant, rugged and flexible extravehicular activity suits are an absolute necessity for mission success. Radi-

ation shielding for lunar inhabitants is also required. This problem is particularly acute for the crew members who conduct the extended traverses (who live out of the pressurized rover) and for all crew members at Initial Operational Capability (when the lander doubles as the lunar surface habitat). The technologies required to use life support consumables as shielding (e.g., water “jacketing” of living areas) and use of local resources (e.g., regolith shielding) must be developed and understood.

Extensive use of robotics augments human exploration. The techniques of robotic teleoperations (including the incorporation of artificial intelligence routines) and telepresence must be developed. Most of the unknowns in telerobotics are in the human factors area. How much time delay can be tolerated before telepresence begins to break down? What kinds of visual display systems are needed? Is stereo vision and high definition (i.e., greater than 5,000 lines) necessary, or are those a luxury? What kinds of manipulator systems are required? Virtually all of these questions require much more study before the machines that will explore the planets in tandem with people can be built.

Enabling Technologies

- **Small Pressurized Rover**
- **Advanced Power Supply**
- **Extravehicular Activity Suit**
- **Radiation Shielding**
- **Teleoperated Robotics**

The Preparation Waypoint represents the activities on the lunar surface which use the Moon as preparation for future missions to Mars.

Waypoint Objective

The objective of the Preparation Waypoint is to use the Moon as a test bed to reduce the risks of a Mars mission. Activities in this waypoint verify operations, systems and procedures on the Moon and identify potential unknowns of Mars systems and operations. The Moon is the optimal test bed for several important reasons:

- Unique reduced gravity environment

- Harsh extraterrestrial environment
- Psychological realism of operations
- Close proximity to Earth
- Evaluation of zero and reduced gravity adaptation with combined orbital and lunar activities

Discussion

The intent of the Preparation Waypoint is to simulate as closely as possible the Mars mission on the surface of the Moon. Specific issues addressed are Mars mission analogs, site selection and cryotank equipment. In this process of validating the Martian equipment, systems and procedures for Mars exploration, valuable lunar exploration is accomplished as a byproduct.

Mars Mission Analog

The Preparation Waypoint compares the Earth and Moon as analogs to simulate a Mars mission. Each have unique characteristics, but considering the overall environment, the Moon is the most complete test bed for a Mars mission. Table 1 summarizes some of the aspects of the Moon that make it the most favorable analog and compares Mars to the Moon and Antarctica, a viable Earth-based

PREPARATION FOR MARS

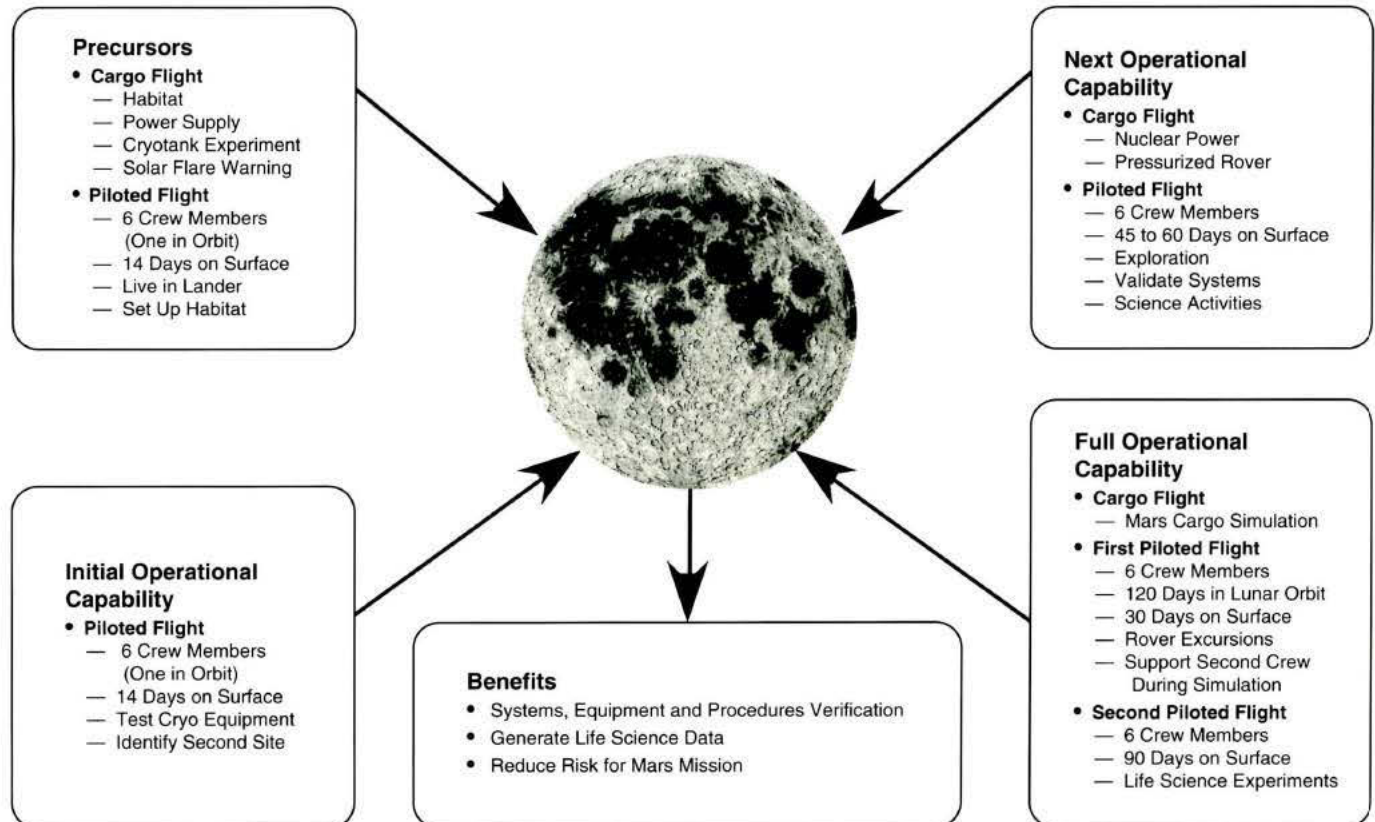

test site. The Moon provides a unique database for life science and operational verification in a reduced gravity environment, combined with the psychological realism of operations at a harsh extraterrestrial location.

In addition, by preceding the Moon simulation activities with orbital activities, the Mars transit operation, equipment and human factor issues are also verified. After a designated time in orbit, the crew travels directly to the lunar surface to conduct the Mars simulation activities. This allows determination of the human adaptation capability in a reduced gravity environment after an extended time in zero gravity.

Site Selection

The lunar site selection is dependent upon Mars site selections. The lunar sites will be selected so that the lunar terrain is similar to that of the Martian terrain to be visited.

Cryotank Experiment

A major uncertainty in Mars missions is the ability to store super-cold cryogenic fuels over long periods with minimum boil-off. A long duration test on the Moon or in lunar orbit provides a unique environment to fieldtest cryogenic storage designs utilizing active refrigeration. Such a system also enhances other lunar operations by providing a reliable backup source of hydrogen.

Initial Operational Capability

The Initial Operational Capability develops operational concepts for future Mars exploration. The Initial Operational Capability is reached after two missions to set up systems. Tasks include the installation of solar flare warning equipment, emplacement of a long-term cryotank verification test and exploration to select the next landing site.

The first mission consists of separate cargo and piloted flights. It is envisioned to begin in 2005, with the cargo mission delivering a habitat, power supply, unloader and the cryotank experiment. The piloted mission follows two to three months later, taking an unpressurized rover and supplies for an expected stay of

ANALOG COMPARISONS

Table 1

Parameter	Mars	Moon Analog	Antarctic Analog
Temperature Extremes	-143°C to 17°C	-173°C to 127°C	-50°C
Length of Year	687 days	28 days	365 days
Rotation	1.026 days	28 days	6 months
Gravity	0.38	0.17	1.00
Surface Pressure	0.006 bar.	None	1.0 to 0.56 bar.
Atmosphere	CO ₂	None	O ₂ N ₂
Dust	Blowing	Clinging	Snow blowing
Climate	Seasons	None	Seasons
Surface	Soil	Regolith	Desert
Storms	Dust	None	Snow
Communications Delay	Up to 38 minutes	Two seconds	None
Mars Extravehicular Activity Simulation	—	Possible	Not possible
Mars Geology	—	Relevant	May not be relevant
Mars Psychological Realism	—	Relevant	Lacks realism
Mars Systems Test	—	Total integration: crew, systems and operations	Limited

14 Earth days. Five of the six crew members live out of the lander, install the solar flare warning system and set up the habitat (including regolith shielding) to establish operational capability for the next crew. The sixth crew member stays in lunar orbit.

In 2006, another six-member crew returns to lunar orbit with five of the crew descending to the first landing site for a 14 Earth day stay in the habitat. They check out the condition of the equipment, check the cryotank verification test, set out portable experiments and look for a second landing site similar to an expected Mars landing site.

Next Operational Capability

After achieving the Initial Operational Capability, a cargo flight returns to the Moon the next year, 2007. This flight carries a pressurized rover (50 km traverse rover) and a nuclear surface power plant to return to the orig-

inal landing site. This is followed in the same year by a mission with six crew members, all of whom descend to the lunar surface. This mission is 45 to 60 days in duration. The crew evaluates the pressurized rover, including the telerobotics. Of necessity, they do meaningful science activities in the process of accomplishing their evaluations. The mission also constitutes a verification of all the procedures required by such operation. The nuclear power system is activated and verified for its acceptability. Equipment is configured to permit continued remote operations subsequent to the mission.

The successful completion of flight constitutes achieving the Next Operational Capability. This flight is the prelude to the dress rehearsal for the Mars mission. The crew also accomplishes the reconnaissance leading to the selection of a nearby Mars rehearsal landing site on the Moon.

Full Operational Capability

Full Operational Capability is a full-scale simulation of a Martian mission at a site on the lunar surface. This provides real time testing and firsthand experience for exploration of the Moon using Martian equipment and procedures. Besides verifying equipment, operations and procedures over an extended period of time, this mission establishes a zero gravity and reduced gravity life sciences database. It also validates the ability of a crew to perform a surface mission after long periods in zero gravity.

Full Operational Capability is achieved with a three-part mission consisting of one cargo and two piloted missions. The cargo flight takes a second habitat, a nuclear power supply, a pressurized rover, an unloader/mover, scientific exploration equipment and communications equipment needed for Mars surface

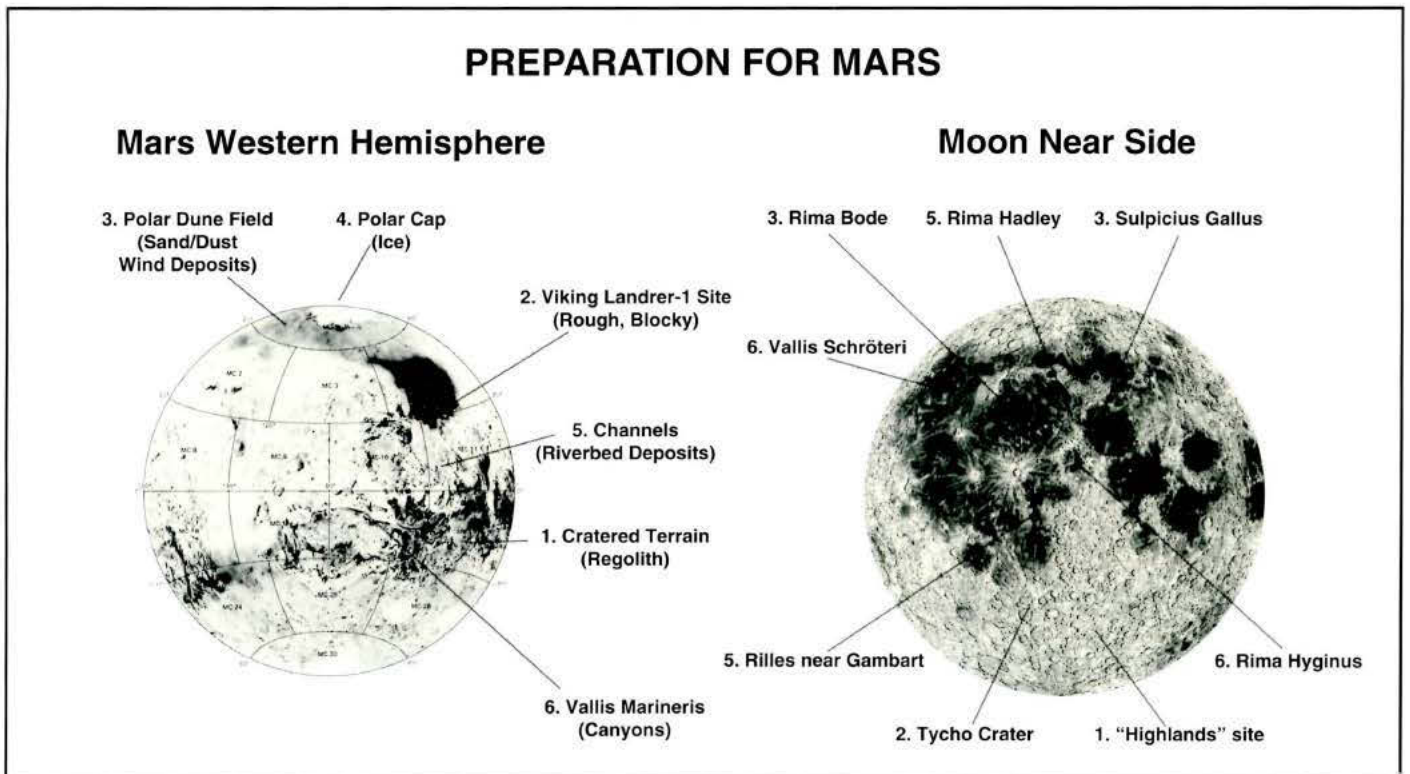

operations in 2008 at a site within 100 km of the Initial Operational Capability landing site. All the systems and equipment are deployed and remotely operated just as they will be on Mars.

The equipment delivered on the cargo flight undergoes a year-long operational validation test. A mission with a crew of six is flown in 2009. The crew stays in lunar orbit for a period of 120 days, a time comparable to a shortened Earth-to-Mars transit, and then descends to the surface to stay an additional 30 days. They accomplish all the activities associated with the Mars mission during their stay, verifying procedures and operations critical to successful completion of the first Mars mission. The vehicles and systems flown, as much as practical, are the same vehicle and systems to be taken to Mars.

For example, the lunar orbiting vehicle is the Mars Transfer Vehicle. The use of this vehicle allows for realistic mission-critical evaluations of the performance of the systems and the crew with a high degree of operational fidelity. It also provides an opportunity to develop the procedures and techniques for having the crew in orbit accomplish meaningful

science using telerobotic systems on the lunar surface. Techniques and procedures developed in lunar orbit directly apply to utilization in Mars orbit. These operations can be accomplished without the time delays inherent in Earth operations of such systems on either the Moon or Mars.

While this flight of 150 days is in progress, a second piloted mission is flown by another six-member crew that descends and lands at the original Initial Operational Capability site with no delay in lunar orbit. Their mission is planned to have them in place on the lunar surface when the 150-day crew lands. Three of the crew members drive to the Mars rehearsal site in a rover and provide assistance to the Mars rehearsal crew after they land. The rehearsal crew is weighted after landing to verify their adaptation to the three-eighths gravity environment of Mars. The crew in place at the site assists in performing necessary life science experiments and protocols. They stay on the Moon after the rehearsal crew departs, verifying equipment operations up to a total mission duration of approximately 90 days.

The advantage of conducting the last two phases simultaneously is that the crew already on the lunar surface serves as a safety net, if necessary, to assist the dress rehearsal crew arriving at the lunar surface from lunar orbit. The effect of a long period in zero gravity and the resulting deterioration of body systems is an unknown factor for predicting crew performance on a planetary surface. The successful completion of this phase of lunar operation constitutes the achievement of Lunar Next Operational Capability-2, The Mars Dress Rehearsal.

Early Milestones

Early milestones include the return of humans to the lunar surface by the year 2005. Other early milestones include setting up a habitat, operating on the lunar surface for a 14 Earth-day initial stay, determining human performance and qualifying of hardware for future Mars missions.

The Preparation Waypoint uses the Moon to provide operational verification of Martian equipment, systems and procedures. In addition, the physiological and psychological

PREPARATION SITE SELECTION

Mars Site

1. Impact-produced cratered terrain (regolith)
2. Bedrock and rough, blocky surfaces (lava plains)
Viking Lander-1 landing site, Chryse Planitia
3. Sand/dust eolian deposits; dunes and duricrust
4. Ice and permafrost terrains (polar ice caps)
5. Fluvial (ancient riverbed) deposits
6. Canyonland terrain (Vallis Marineris)

Moon Site

1. Any highlands site
2. Melt "pond" north of King Crater
(far side) Floor of Tycho
3. Rima Bode; Sulpicius Gallus
4. No known analog
5. Rima Hadley; Rilles near Gambart
6. Vallis Schröteri; Rima Hyginus

issues concerning Mars missions are addressed. Lunar missions can also be combined with orbital activities as a byproduct to completely simulate the long duration, zero gravity transit to Mars, followed by activities on the reduced gravity surface. These activities will provide a database on human physiology and performance. From a total mission perspective, the Moon is the best Mars analog available.

Enabling Technologies

Several technological developments are required for the successful implementation of this waypoint. As in other waypoints, the capability to launch a large payload to low Earth orbit is required; 150 metric tons with designed growth to 250 metric tons. Cryogenic fuels must be stored with minimal boil-off for long periods of time (year-long scales). This storage technology is developed around the

use of liquid hydrogen, the most difficult cryogen to keep for long periods. The long duration of human flights to Mars requires the development of radiation protection for people. Such protection includes not only shielding the spacecraft and habitats from normal galactic cosmic rays, but a system to provide early warning of solar flare events and the provision of storm shelters for human occupancy during such events. Closing the life support loop is highly desirable, but complete closure is not required to go to Mars. Research should continue on life support system closure to reduce launch weight as much as possible, with emphasis on closing the oxygen and water loops. Finally, significant operations on both the Moon and on Mars require reliable and robust surface power systems. We believe this dictates the need for nuclear reactors on planetary surfaces for long term human presence.

Enabling Technologies

- **Cryogenic refrigeration necessary for storage over long missions**
- **Heavy lift launch capability**
- **Solar flare warning system**
- **Nuclear surface power for long term operations**
- **Maximize closed loop life support to reduce mission weight and test system reliability**

The Habitation Waypoint investigates the technologies and the progression of activities that support humans in sustained operations on the lunar surface.

Waypoint Objective

The objective of the Habitation Waypoint is to investigate the technologies that support the evolution of sustained operations on the lunar surface leading to a permanent lunar presence.

There are two classes of lunar habitats: 1) the simplest class, a pressure vessel which provides basic living space protection; and 2) a more sophisticated class, which expands this containment vessel and provides command, control and communica-

tions, laboratories, workshops, pressurized storage and life support systems. This waypoint discusses the broader class because of emphasis on continued human presence.

Basic requirements affect both the design of the vessel and the infrastructure evolution. The requirements include: 1) whether the vessel is prefabricated or constructed on-site; 2) that it is designed to the ambient site conditions; 3) that it ensures adequate radiation and micrometeorite protection; 4) the length of use; and 5) human factors.

Discussion

A review of the habitat concepts in the Outreach Program and in existing literature reveals very little detailed

engineering design. On the other hand, several habitat-related technologies have multiple development lines that could be followed, each with its own merits and drawbacks.

One major issue involves the evolution of habitat structures. Habitats can be built by mating modules to build up capability, or by using constructible technology or a combination of the two. A construction approach can be further differentiated into inflatable or expandable techniques.

Movement of large volumes and masses for habitats is critical, but it must be determined if vertical lifting capability is to be included along with the need to move elements horizontally.

Habitat design issues include: airlock, visual options, crew space, life

HABITATION

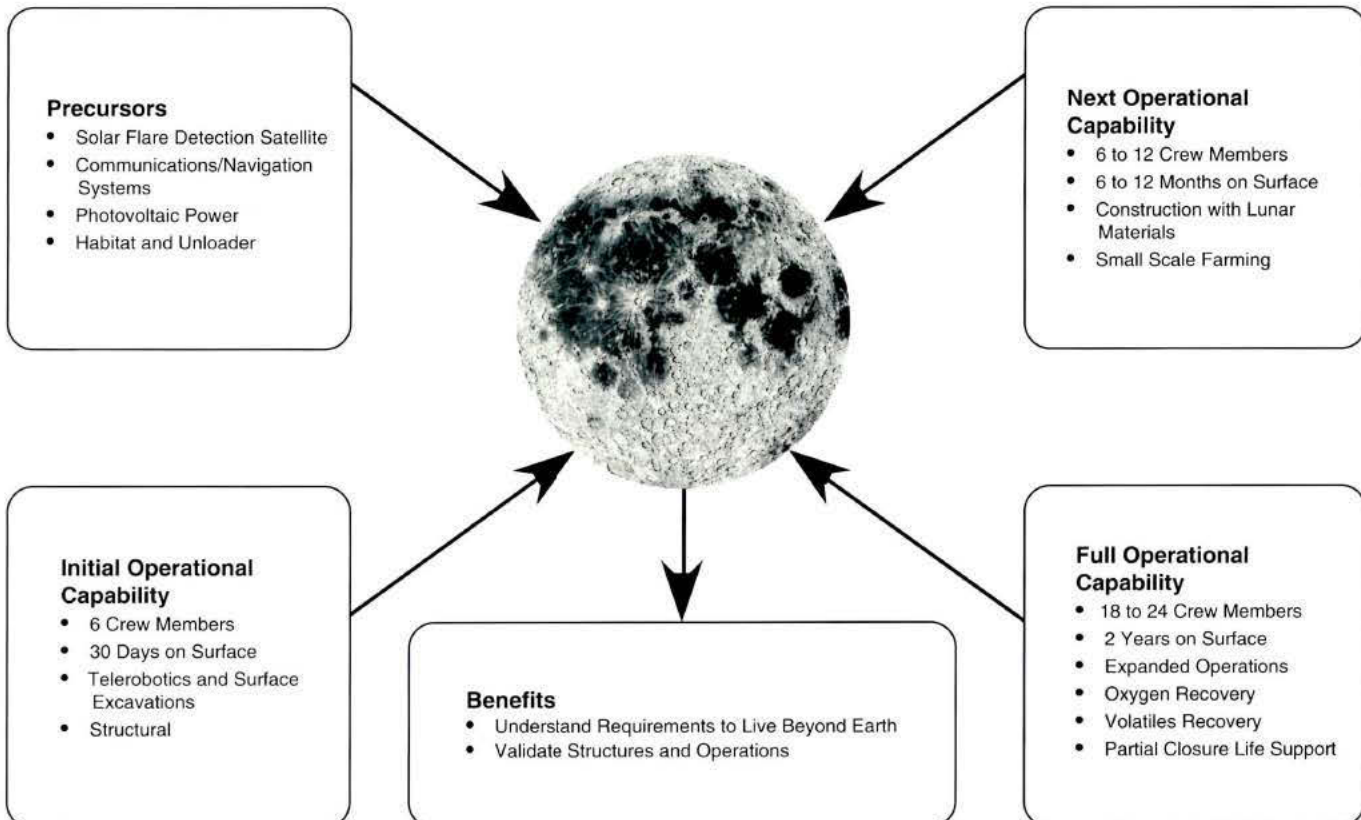

support and life sciences. An airlock provides the capability for astronauts to continue to work within the habitat during ingress/egress by other crew members. The amount and type of airlock usage for lunar operations need to be defined. Visual options include windows, periscopes and video displays. Life science issues related to habitat design deal with shielding, life support and human factors.

Beyond micrometeorite protection, the habitat must be shielded to protect the crew from radiation. The structure can use lunar regolith either underground or above ground. An unshielded habitat would require some kind of storm shelter to protect against the effects of solar flares and define limits on exposure to galactic cosmic radiation. Also, the issue of closed life support systems versus open life support systems greatly affects the design and mass of the habitat and storage sheds. Human operations continue to expand in an incremental capability to increase their independence from Earth. In the process of accomplishing this activity, the lifeline from Earth becomes more of a communication line than a logistic lifeline, enabling humans on both planets to share each other's experiences.

Initial Operational Capability

This waypoint is built to demonstrate the ability of humans to live and perform productive tasks in the lunar environment. As such, the tasks and equipment are developed in successive steps, leading from the basic survival needs of food and shelter and progressing toward fuller capabilities. The Initial Operational Capability allows a small crew to stay for short periods in a confined space, but reaffirms the basic lessons learned in the Apollo program. New materials will allow significant advancement in equipment from the pioneering

efforts of the past. These materials must be proven in small scale tests prior to the commitment of humans in large numbers and for longer periods.

Work performed is centered first on the tasks needed to construct the initial habitat and airlock with supporting power and shielding. These tasks also serve a secondary purpose of allowing the crew to learn how to work with the tools provided. They are the steppingstones to further capabilities on the Moon as well as beginning the lessons for eventual Mars operations. In order to include the public in the space experience, many of the activities are transmitted to Earth, where high-definition television allows students and the general public to view day-to-day action.

A pre-deployed cargo mission includes a communications package, initial power capability and moving equipment to handle bulk material. This capability is met by the landing and activation of a pressure vessel habitat onto the lunar surface. This habitat houses a crew of six and will serve as the center for future construction operations. This construction will be done by a combination of telerobotic and crew surface operations.

The initial capability is characterized by austere living conditions. Included is full closure (95-100%) in air systems, partial closure (30-50%) for water systems and no closure in food and waste systems. Limited space is dedicated to medical care and health monitoring as well as exercise facilities. If future habitats use in situ resources to supplement these partially closed systems, demonstration programs for recovery of air and water from in situ resource utilization should be initiated early in the program.

The extent of telerobotic assembly and excavation operations affect the work space requirements. Radiation and micrometeorite protection will be

provided by a sufficiently thick (1 to 3 m) regolith cover added by the crew on site.

Expansion during this phase involves placement and mating of additional airlocks plus pressure vessels for habitation, laboratory and storage. Approximately 30 metric tons of lunar surface delivery capacity are required. The introduction of a power capability that does not require large energy storage for lunar night (i.e., a continuous nuclear-driven power generator) and a constructible/expandable habitat package mark the movement toward the Next Operational Capability.

Next Operational Capability

The Next Operational Capability is marked by the evolution from mating of multiple Earth-derived pressure vessels to the construction of expandable or inflatable structures. The concept for the next capability level is that equal or greater habitation volume will be made available for less mass. This need involves more sophisticated and complex construction practices than have been developed earlier. Crew surface operations for the assembly of habitat components will be extensive. The introduction of more capable airlock operations is necessary to support the increased crew egress frequency and a larger resupply requirement.

Crew size will grow to 12 for uninterrupted stays of six to 12 months, with an appropriate resupply rate. Because of the increase in the amount of consumables that will be needed, improvements in the efficiency of water recycling should approach 70 to 80%. In addition, the waste management cycle should approach partial closure. To achieve this, consideration must be given to the processing of waste stored during previous missions. Food cycles will remain open with continued demonstration of closure programs like "salad machine"

technology and potential “elemental supplements” diets.

Larger crew size and longer stays will require increased personal living space. This will focus on life science issues such as crew health, environmental monitoring, human factors and other biomedical issues. For longer missions, radiation and micrometeorite protection would likely incorporate a hybrid system of bulk regolith and structural design.

Full Operational Capability

This level utilizes combinations of the habitat structures and routine surface operations to validate full-time lunar presence. In this phase, local resources allow the recovery of volatiles from lunar materials necessary to support the infrastructure. This includes recovering oxygen for both the atmosphere of the habitat and for use as a propellant. The crew size increases to 20 to 24 for continuous stays of up to two years, with appropriate resupply. Waste closure is targeted at 95-100%, but the food cycle remains open, although with advances toward partial closure in demonstration programs.

Early Milestones

Earth-based testing validates subsystem designs. This is done in environments which can best simulate lunar conditions. Early launches begin with small scale operations in order to try operational techniques for movement, construction and basic elements of human survival in space.

The first steps toward implementing this waypoint consist of relatively large scale testing in Earth simulation facilities and some small scale testing on the Moon. The Earth-based phase tests the design of the habitat, proto-

type mechanisms of payload unloading, and concepts of substrate excavation (including pyrotechnics) for habitat emplacement. Lunar operations in this phase are at the bench scale and concept level. Testing involves regolith and substrate characterization, movement of loose regolith, and testing of the prototype construction equipment.

Full scale lunar operations consist of both a cargo and piloted flight. The cargo vehicle contains the pressure vessel habitat, airlock, power system, rover, and some initial food production test equipment. The piloted flight delivers the crew to the surface; once there, they conduct surface operations that emphasize living and working on the Moon. This consists of mobility tests (both for the rover and people) and construction operations. Task evaluation in construction will entail site preparation, installation of the power system and some initial, experimental food production.

Enabling Technologies and Processes

A number of technologies and processes underlie the Habitation Waypoint. Some of these relate specifically to habitat design, while others relate to activities or processes for handling, protecting or maintaining the habitat.

A number of required technologies and processes underlie the Habitation Waypoint. A safe and reliable airlock, closure of the life support loop (including waste management and food production) and excavation and construction techniques are required to emplace and operate the lunar habitat. Human safety for long-duration stays on the Moon require radiation protection; specific technology requirements include development of

an early warning system for solar flares, radiation protection technologies and efficient methods of handling of loose regolith (for shielding). Medical care facilities must be provided for crew members, including both medical treatment facilities and robotics technology for telemedicine. The Habitation Waypoint will also profit from the general technology development for robotic telepresence, both for construction operations and for general maintenance once the habitat is constructed.

Enabling Technologies

- **Airlock**
- **Closed loop life support system**
- **Excavation and construction techniques**
- **Radiation protection and shielding**
- **Medical facilities**
- **Telepresence robotics**

Waypoint Objective

The science of astronomy is an important part of the nation’s scientific efforts. The Sun and the stars are laboratories for the understanding of atomic, nuclear and subatomic processes. Interstellar gas, galactic structures and objects like quasars and black holes may hold the key to understanding gravity and the elements of any unified theory which may exist. Fusion power, ecological data, effects of the interaction of matter and energy and the understanding of the origin of life will all have profound effects on our technology and vision in the future.

The Lunar Based Observation Waypoint provides a human-tended, multi-site, sophisticated set of obser-

vatories. These observatories will provide for long term, multispectral coverage of space and expansion to future far-side and other remote observing sites.

Benefits of the Moon

The effectiveness of the Moon as a site for astronomical observations was examined to determine whether or not the Moon was the only location to emplace an instrument, a highly desirable location to emplace an instrument, or simply an optional location to emplace an instrument. Reasons to use the Moon include:

- The existence of a vacuum on the Moon with a dark sky

- The size and stability of the lunar surface for large baseline instrumentation
- Partial cosmic ray protection
- A near-cryogenic temperature environment
- Low gravity to reduce instrument support mass
- Slow rotation to reveal the entire sky
- Distance from Earth and its electromagnetic environment

LUNAR BASED OBSERVATION

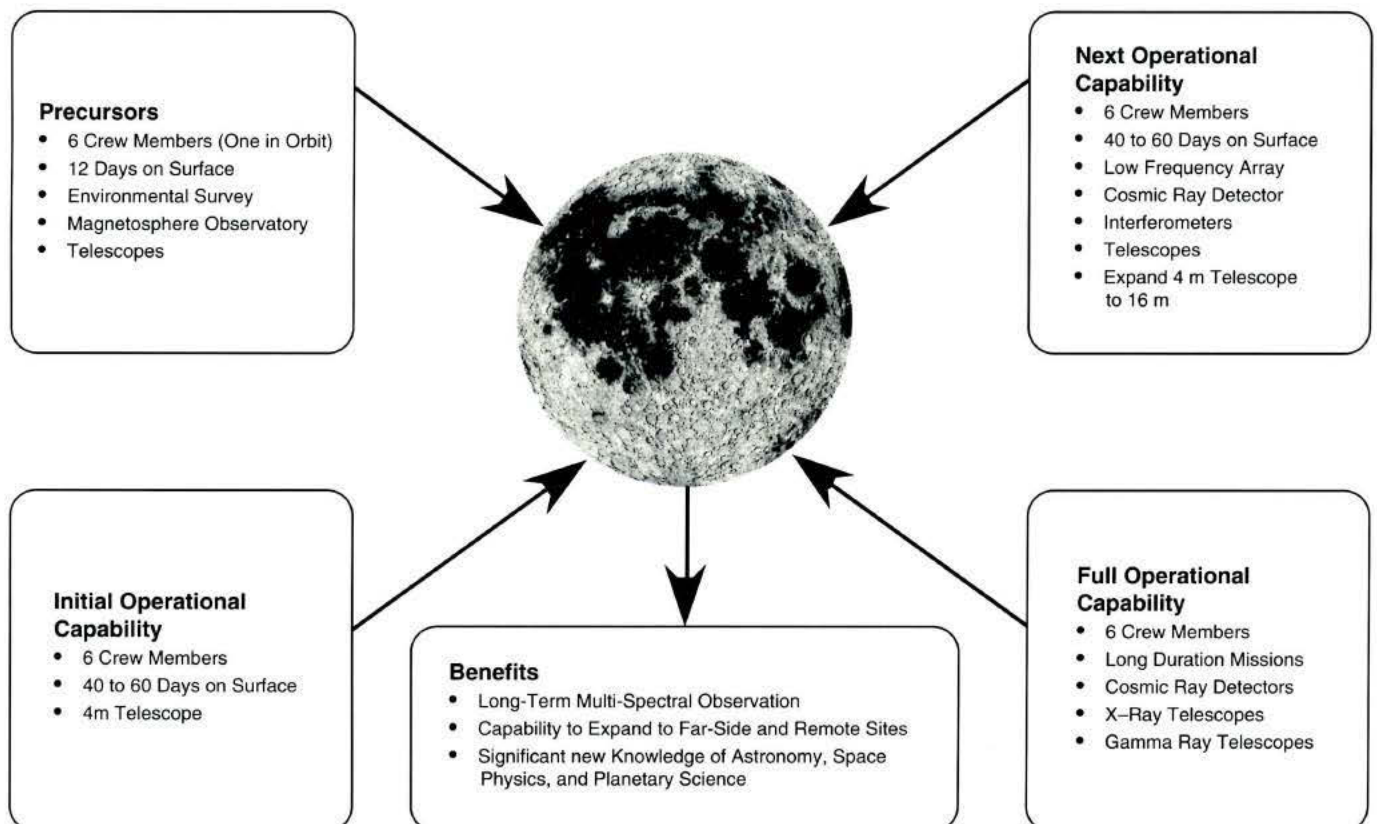

Limitations of the Moon

Factors that make the Moon a less optimum place for observation include the logistics of getting instruments to the lunar surface, limits to extravehicular activity operations, effects of lunar dust on equipment, and the unique engineering environment.

Limitations of Earth Orbit

Once above the Earth's atmosphere, virtually the same sky exists for observational purposes. However, some of the reasons that make this option less desirable are: debris in low-Earth orbit; gas ionization and atmospheric drag, obscuring multi-spectral radiation from Earth; rapid thermal gradients experienced because of the Earth's shielding of solar flux; stability problems for pointing and tracking; and physical blocking of targets by the Earth.

Initial Operational Capability

The objective of the Initial Operational Capability is to take advantage of the lunar surface in establishing a modest observational capability. This will be a satisfactory accomplishment if no other instruments are deployed. The instruments required to meet Initial Operational Capability provide a better understanding of the emplacement, operations and maintenance of lunar based instruments. This provides the basis for deciding on options for emplacing larger, more complex instruments requiring extensive human support.

The Initial Operational Capability requires at least one 10 to 12 day mission by five astronauts (one astronaut remains in lunar orbit) to an equatorial site within a few degrees of a limb. Using both piloted and robotic rovers, the astronauts will survey the surface and the top few meters of the regolith over an area of approximately 10 m².

The instrument set for the Initial Operational Capability consists of:

- 1) *Environmental Survey Instrument:* This is the initial portable instrument delivered to the lunar surface to provide data for future construction purposes. The station is envisioned as a suite of small instruments to measure basic engineering data (radiation, temperature, seismic information, galactic cosmic rays, micrometeor flux, etc.). Mass is estimated as 100 kg with a power requirement of 10 We and 1 kbps data rate.
- 2) *Magnetospheric Observatory:* This is a space physics portable package deployed by a crew member. It can be easily accommodated in early missions because of its small mass. The purpose of the instrument is to study the solar wind and its interaction with the Earth's magnetosphere. The observatory is envisioned to include a magnetometer, solar wind detector, and photon and neutral atom imaging instruments. The anticipated mass is 10 kg with a power requirement of 30 We and a 1 kbps data rate.
- 3) *Operations Test Telescope:* This will be a small, 1 m class optical telescope placed on the lunar surface during one of the initial survey missions. It is a simple telescope with a scanning capability. The unit is envisioned to acquire targets selected by an Earth control station, track them, and transmit images back to the Earth station. The image sensor will be a cooled, large-format charge coupled diode array; the entire system is estimated to have a mass of 300 kg, with a 100 We power requirement and a 2 Mbps data rate.

- 4) *Transit Telescope:* The 2 m lunar transit telescope is a robotically emplaced system that provides an all-sky survey in the ultraviolet, visible and infrared ranges. The telescope is fixed so that the slow lunar rotation will allow integration times of hours. The Moon's rotation supplies one axis of motion. A large mosaic-charged coupled diode array sensor is used as a shift register at the proper rate to compensate for the rotation, allowing long integration times. A reflective sunscreen shields the telescope from Sun and Earth light and allows the detectors to be passively cooled down to 100°K. An estimated total site system mass is 1.3 metric tons, with a 400 We power requirement and a 30 Mbps data rate.

Next Operational Capability

The emplacement of more sophisticated instruments requires the presence of astronauts to assemble and check them out. Support for the astronauts will be provided by a permanent habitat. Surface mobility will require an unpressurized rover and some form of teleoperated deployment capability. Subsequent emplacement of instruments, which significantly increase operational capability, is defined as Next Operational Capabilities 1, 2, 3. These next operational capabilities require more astronaut activity and the capability of transferring heavy components from cargo landers to their deployment/assembly points. This will be enabled by the establishment of a habitat that supports six astronauts for a period of 40 to 60 days and the provision of a robotic equipment mover.

Next Operational Capability-1. The first Next Operational Capability establishes the infrastructure on the lunar surface for building up a com-

plement of observational instruments. Returning optical images to Earth is the highest priority of this Next Operational Capability, so its major instrument is the 4 m telescope. This is the initial increment of an optical instrument capable of detecting Earth-like planets around nearby stars. Ultimately, the 4 m telescope will be complemented with additional 4 m segments to give a total aperture of 16 m. The 4 m telescope will also be used as one of the collecting elements of the optical/infrared interferometer to be emplaced later. The telescope is envisioned as a 4 m filled aperture, diffraction limited, wide field-of-view telescope. The structure and optics are passively cooled to 100°K and the detectors may require active cooling. The basic instrument is robotically delivered to the site as a single package, with an estimated mass of 15 metric tons, a power requirement of 3 kWe and a 10 Mbps data rate.

Next Operational Capability-2. The second Next Operational Capability takes advantage of the Moon's unique stable-surface, interferometric measurements. Also, due to the Moon's low plasma frequency and near absence of a magnetic field, a low frequency array and cosmic ray detector are set up. The low frequency array studies diverse phenomena in the fields of extragalactic astronomy, galactic astronomy, and Solar System science, including mapping the auroral radiation around the Earth. Since this frequency range is not well explored, the most important scientific results may be from the discovery of new classes of objects and phenomena. The system is envisioned as 19 stations located in a "T" formation with three arms, each 36 km long. Each station has two 10 m dipoles with a receiver and a digitizer. System mass is estimated as 1 metric ton, with a power requirement of 100 We and a data rate of 32 kbps.

The low energy cosmic ray detector, which allows the study of the physical processes responsible for forming chemical elements, relies on detailed measurements of the relative abundance of all the elements and their isotopes. Galactic cosmic radiation, consisting of atomic nuclei that have been accelerated to relativistic speeds, is uniquely important because it carries fresh matter from supernovae and other galactic bodies. The Moon has both a very small magnetic field and no atmosphere, thus providing the ideal location to conduct these measurements. The detector is envisioned as a cylindrical ion chamber, 2.5 m in diameter and 4 m tall. Its mass is estimated as 3 metric tons with a power requirement of 500 We and a 10 kbps data rate.

The submillimeter interferometer examines astronomical objects at submillimeter wavelengths and at spatial resolutions many orders of magnitude better than is capable from Earth. It also observes compact galactic sources over a wide frequency range, part of which is blocked by the Earth's atmosphere. The interferometer is envisioned as a 5 m diameter antenna on the lunar surface. The initial baseline is on the order of 50 m, later growing to 10 km as the final configuration of seven antennas is built up. The first three antennas have sensors for the 200 to 1000 micron wavelength range. As the array is completed, sensors are upgraded to cover the 30 to 1000 micron range. Active cooling to less than 100°K is required. Mass is estimated as 14 metric tons for seven elements having a 20 kWe power requirement and a 100 kbps data rate.

The optical interferometer observatory conducts ultra-high resolution optical astronomy via direct (non-heterodyne) interferometry. In its ultimate configuration, the interferometer will be capable of producing detailed images with six orders of magnitude increase in resolution

compared to Earth-based telescopes. It has the capability to:

- Directly detect and characterize Earth-like planets around nearby stars
- Image mass transfer binary systems where one component is a massive compact object, such as a black hole
- Resolve the broad-line and narrow-line regions in active galactic nuclei
- Image accretion disks around supermassive black holes
- Observe parallax of objects to several mega-parsecs
- Indirectly detect Jupiter-sized planets within the visible part of our galaxy
- Determine the mass of Earth-like planets which may be discovered by imaging

In its final configuration, the optical interferometer observatory is envisioned to consist of 12 optical telescopes with 1.5 m apertures, employing a beam combiner and correlator, and 12 moveable optical delay line carts. The separate telescopes function together as a single very large aperture observatory with the 4 m telescope as the base instrument. The signal delay line carts carry mirrors along straight paths to provide coarse optical path length compensation. Precision path length adjustment is provided within the beam combiner facility. The telescope optics are passively cooled while the detectors will require active cooling. An initial configuration of three telescopes with 100 m baselines (telescope to telescope) can conduct significant observations and later evolve into a complete facility with 10 km baselines. Total operational system mass is estimated as 16 metric

tons, with a power requirements of 9 kWe and a data rate of 1 Mbps.

Next Operational Capability-3. The third Next Operational Capability builds on the infrastructure established earlier by completing construction of the 16 m optical telescope. At this time, enough experience has evolved to set up a radio telescope, which will be a node in a very long baseline array. The 16 m telescope is the final increment of the instrument begun at Next Operational Capability-2 to detect Earth-like planets around nearby stars. The initial 4 m telescope is complemented with additional 4 m segments to give a total aperture of 16 m. The telescope is capable of various ultra-high sensitivity, ultraviolet, visible and infrared wavelength astronomical studies. The telescope is also used as one of the collecting elements of the optical/infrared interferometer. The structure and optics are passively cooled to 100°K, while the detectors may require active cooling. The 16 m telescope is an important additional element in the optical interferometer, thus significantly increasing the interferometer's effective collecting area. Total mass is estimated as 42 metric tons, with a 5 kWe power requirement and a 10 Mbps data rate.

A Moon-Earth radio telescope extends the technology of interferometry to a baseline extending from the Earth to the Moon, essentially creating a radio telescope with a 384,000 km long baseline. High sensitivity observations of radio emissions are then possible. The lunar radio telescope is envisioned as a 25 m parabolic dish used in conjunction with Earth-based and Earth-orbiting telescopes at a 10 GHz frequency. Mass is estimated at four metric tons, with a power requirement of 15 kWe and a data rate of 10 Mbps.

Full Operational Capability

The Moon will have a mature and robust observational capability at Full

Operational Capability. This involves emplacing additional instruments to cover the high energy part of both the electromagnetic and cosmic ray spectrum. The high-energy cosmic ray detector will identify cosmic rays that provide the only directly accessible sample of matter outside the Solar System. The almost complete absence of a magnetic field and atmosphere on the lunar surface provides the ability, for the first time, to directly measure the isotopic component of these high energy cosmic rays. The detector is envisioned as having alternating layers of plastic scintillator or drift chambers, with layers of passive lunar regolith providing the intervening target mass. A charge measurement layer is on top of the 3.6 m deep instrument. Detection of particles will range from 1,000 GeV to 10,000,000 GeV. Delivered system mass is estimated as three metric tons, not including lunar excavating requirements, a power requirement of 1 kWe and a 10 kbps data rate.

The lunar environment provides a highly stable base for a long focal length, hard x-ray imaging telescope. The telescope operates as an untended, unpointed, transit telescope for x-ray astronomy studies in the energy range 10 to 50 keV. This band is key for the study of non-thermal emissions as cyclotron lines from compact sources fall into this band. The instrument is envisioned as a nested, high throughput mirror constructed from lightweight, flat grazing-incidence reflector plates. An imaging hard x-ray detector with 1mm spatial resolution is placed separately on the lunar surface. Mass is estimated at 2 metric tons, with a power requirement of 1 kWe and a 100 kbps data rate.

The gamma ray telescope provides high spectral resolution measurements of cosmic and solar gamma ray lines. The gamma ray telescope will study a broad range of transient phenomena such as gamma ray bursts, supernova shock breakout, and flare stars. It can also provide radiation

and solar flare monitoring. The instrument is envisioned as a cooled array of germanium gamma ray detectors covering the energy range from 10 keV to 10 MeV placed behind a coded mask. The mask-detector assembly is based in a 6 m deep cavern in the lunar regolith and shielded by a 2 m ceiling. A mass of three metric tons is estimated with a power requirement of 1 kWe and a data rate of 25 kbps.

Instrument Priorities

The proposed sequence of the instruments in the Observation Waypoint is a function of the difficulty of emplacing them and of their ability to produce major scientific discoveries. If scientific importance were the only criterion, the priorities would be:

- High
 - 4/16 m telescope
 - Optical interferometer
 - Submillimeter interferometer
- Medium
 - Transit telescope
 - 25 m radio telescope
 - High energy cosmic ray observatory
 - X-ray telescope
 - Gamma ray telescope
- Low
 - Magnetospheric observatory
 - Low energy cosmic ray detector
 - Very low frequency array

Early Milestones

Small, portable astronomical instruments can be deployed on the first

lunar mission. These instruments, although relatively unsophisticated, have the ability to immediately transmit data back to Earth. Each subsequent instrument placed on the Moon will open up an entirely different part of the electromagnetic spectrum that may yield significant results. For example, very low frequency array (less than 2 MHz) observations cannot be made on Earth because of atmospheric attenuation.

There are no limiting technology requirements, and the enhancing technologies are generally those that will be pursued in the further development of Earth- and space-based instruments. However, there are some system issues that require attention. The problem of dust can be resolved by locating sensitive instruments 10 km from areas where there is extensive astronaut activity. This

cannot be a complete solution since the astronauts will be required to work around the instruments. The system designs must incorporate procedures for protecting sensitive surfaces and, if necessary, cleaning them. The designs must also be highly modular for easy assembly, maintenance and upgrading. The assembly procedures that require operations by suited astronauts and robotic equipment will differ significantly from procedures used on the Earth. The variations of temperature can result in significant changes in the properties of elements such as the primary reflector of the 4/16 m telescope. Careful design can minimize thermal effects, but there will also be the requirement to have a dynamic surface measurement and adjustment capability in order to maintain instrument performance.

The Fuels Waypoint includes activities on the lunar surface to provide fuel and other materials to support space exploration.

Waypoint Objective

The objective of the Fuels Waypoint is to provide propellants and materials from lunar resources to support space exploration. An additional objective of the Fuels Waypoint is to reduce the transportation costs of all other lunar waypoints, if they are pursued past Initial Operational Capability, by substantially reducing Earth-to-orbit mass launch requirements. If large scale recovery of resources is to be undertaken and manufacturing facilities are to be established, these activities are synergistic with those of the

Energy Waypoint, where volatile recovery and semiconductor and structural materials production are developed.

Discussion

Studies indicate that for missions to Mars, approximately 80% of the vehicle mass is propellant. For chemical propulsion, the mass requirement at low-Earth orbit is greater than 1000 metric tons. These figures are possibly large enough to justify the development of lunar resources.

Studies also indicate that to take full advantage of lunar resources, propellants must be utilized in lunar orbit or at a Earth-Moon Lagrange Point and be well-utilized high in the Earth's gravity (i.e., in lunar orbit or at a Lagrange point). Thus, it could be

possible to use lunar propellants combined with a transport system capable of using these propellants to land and launch payloads from the lunar surface for transporting mass from low Earth orbit to low lunar orbit.

Potential Savings by Use of Lunar Produced Fuels

The degree of savings to an exploration program depends on the extent and performance of the infrastructure. Lunar-derived propellants will reduce the Earth-to-orbit mass required for a Mars trip by approximately 50%; however, technology for on-orbit fuel transfer must be developed. These savings are comparable with the Earth-to-orbit mass required to put the lunar propellant production facility in place. If lunar fuel and

FUELS

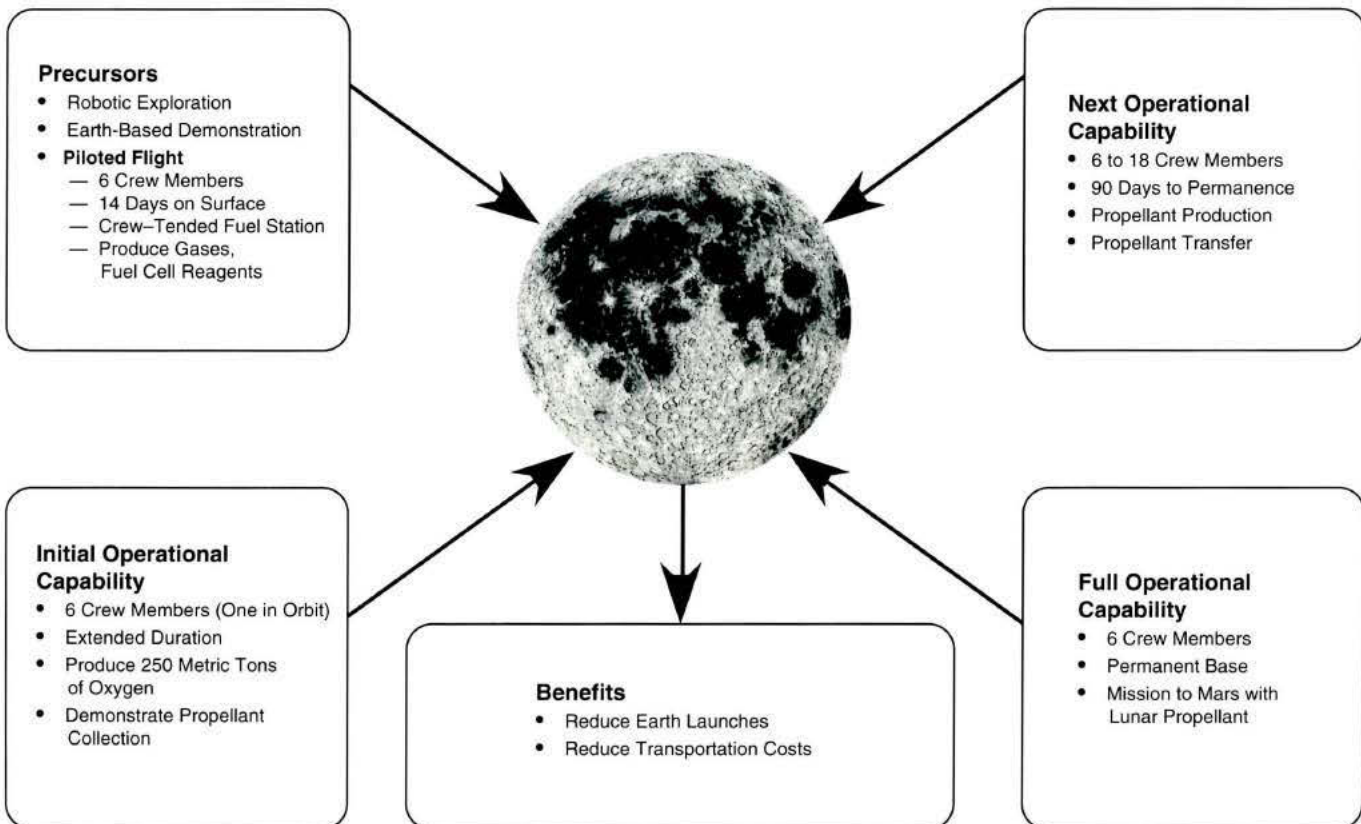

oxidizer are produced and utilized for all transport above low Earth orbit, mass requirements for Mars mission equipment to low Earth orbit may be reduced.

Useful Materials on the Moon

There are a number of useful materials available on the Moon's surface, including ilmenite (a source of oxygen, iron and titanium) and anorthite (a source of oxygen and aluminum).

Although the Moon has less volatile elements than the Earth, its volatiles are in the lunar surface soil or regolith, mostly as implanted gases (e.g., hydrogen and nitrogen) and light elements (e.g., sulfur and carbon) from the solar wind. Both the volatiles implanted by the solar wind and the chemically bound oxygen found in the lunar regolith can be extracted for a variety of practical uses.

The utilization of lunar materials will require both new technology development and operations concept development. This process becomes cost effective with sustained operations.

Processes and Feedstocks

The choice of a process for the development of lunar materials is critical, both in terms of requirements for surface operations and for the potential fuel yield. Process options can be divided into two categories: those that are feedstock-dependent (ore) and those that are feedstock-independent. Feedstock-dependent processes require an involved set of precursor missions. In contrast, feedstock-independent processes use whatever materials exist at the site, minimizing precursor needs. Feedstock-dependent processes have the advantage of requiring less energy than do feedstock-independent processes for a given quantity of product. Their drawback, however, is that they require the identification of enriched

feedstocks on the Moon. Ores may occur naturally (e.g., a high concentration of solar wind gases adjacent to a magnetic anomaly) or they may be manufactured (e.g., electromagneto-static separation of ilmenite from the regolith). Lunar ore concentration must be identified and characterized before establishing a processing plant.

Precursors

Three types of precursor activities are required for the Fuels Waypoint. Precursors should be of modest cost and focused on obtaining resource relevant data. Robotic lunar exploration will be used to examine resource sites. The Apollo 11 and 17 sites are the most attractive known sites from a resource standpoint. They consist of high-titanium mare regolith, rich in ilmenite, a feedstock common to several suggested processes. A robotic surface rover could survey the site and characterize the resources. The rover would be teleoperated from the Earth and would measure chemical, mineralogical, and physical soil properties. In addition, direct on-site measurements would be made of the quantities of volatiles present in the soil.

As in the Energy Waypoint, Earth-based experiments to develop resource processes using simulated lunar materials and actual lunar samples will also be required. These experiments would serve to define the most attractive processes and provide the basis for actual prototype plant development. Experiments might be conducted under simulated lunar conditions of vacuum, thermal and dust environments. A telerobotic engineering experiment station at the selected site would be deployed to demonstrate aspects of resource processing. This experiment station may be robotic (teleoperated from the Earth) or it may require crew-tending for full capability. Its purpose is to establish the feasibility of selected processes in the actual lunar environ-

ment and test the activities required to produce propellant and other useful products on the Moon. This station would have a mass of 2 to 3 metric tons, require several kilowatts of electrical power, and tens to hundreds of kilowatts of thermal process heat. This energy could come from solar concentrators and photovoltaics, regenerative fuel cells or a small nuclear reactor.

A cargo mission could emplace this station. The first crew to return to the Moon could set it up and operate it during a short stay (14 Earth days). An experiment on this scale would produce useful quantities of breathing gases, fuel cell reagents and possibly some structural materials. It would provide the engineering data necessary for the design of future plants or capabilities.

Robotic Operations

The experimental plant would also operate while the site is unattended, building up a considerable stock of useful materials for later use. Experience on Earth suggests total automation of the plant is impractical, but some level of automation will be critical to economical materials processing activities. On the Moon, where communication time to Earth is short, the plant would operate telerobotically without being completely autonomous. Estimates suggest a successful experimental plant could produce several metric tons of useful materials over the span of a year. Specific robotic activities could include:

- Regolith preparation and mineral component separation
- Regolith bagged for shielding
- Ilmenite reduction for oxygen production
- Magma electrolysis

- Volatile extraction and separation
- Water electrolysis
- Cryogenic liquification and storage
- Disposal of spent material

Technical issues to be addressed include energy and power recovery, machine lifetime and wear patterns, and process efficiency; that is, mass of useful product per mass of processed regolith.

Initial Operational Capability

Following these precursor activities, a pilot plant would be delivered at the selected site with a crew of six to remain for an extended time. The Initial Operational Capability will be achieved when lunar surface operations are producing 250 metric tons of liquid oxygen per year.

The creation of more lunar activity will be the cornerstone of this waypoint. For example, solar thermal concentrators or photovoltaic arrays used to supply energy for processing will be produced from lunar materials mined during the previous stages. The most desirable initial processes are those that use lunar-derived propellants to enable delivery of additional payloads to and from the lunar surface and enhance the construction of the support infrastructure (e.g., habitat emplacement, landing pad grading, roads for dust-spray reduction).

Process and Products

A baseline process is to heat high-titanium content regolith to extract hydrogen, reduce the ilmenite to produce oxygen, and collect resulting byproducts. This largely feedstock-independent method of oxygen production is a low-yield process. At an Apollo 11-type site, for example, 327

metric tons of regolith would have to be processed to produce one metric ton of oxygen. One metric ton of oxygen will support a crew member for 1,000 days. This is the only known way to extract solar wind volatiles. The mass and power requirements for industrial scale processing of regolith in this manner are well understood. To derive 250 metric tons of oxygen per year from this process, ilmenite reduction would have to be performed on approximately 82,000 metric tons of high-titanium regolith per year.

Vehicle Refueling

The handling and transfer of cryogenic propellants produced on the Moon for vehicles on the lunar surface and in orbit are critical.

Next Operational Capability

Next Operational Capability-1. The first Next Operational Capability will supply up to 500 metric tons of fuel. The lunar launch infrastructure must be able to deliver the necessary propellants and transfer them to the Mars transfer vehicle. Lunar ascent/descent vehicles of 40 to 100 metric ton capacity appear feasible, suggesting that five to 15 flights would be required to fuel the Mars transfer vehicle.

Next Operational Capability-2. The second Next Operational Capability will demonstrate a complete mission to Mars. Lunar produced fuels can be more advantageous if an additional piece of transportation infrastructure is added to the Fuels Waypoint at Next Operational Capability-2. This is a high-efficiency cargo barge to transfer payloads between low Earth and low lunar orbits. The barge could also transfer the dry Mars transfer vehicle from low Earth orbit to await fueling at the space-based mission staging node. An electric propulsion vehicle could perform barge opera-

tions because there is no requirement for short flight times on cargo missions. An electric propulsion spacecraft would cover the Earth-Moon distance in about 100 days. Automated or supervised payload docking and fueling would be required, and space assembly minimized.

Next Operational Capability uses this transport and fuel production infrastructure to launch a piloted mission to Mars with just one or two Earth-launched flights required for the dry Mars transfer vehicle. By comparison, at least 10 launches are required for most all-chemical missions to Mars when terrestrially produced propellant is used.

Full Operational Capability

By Full Operational Capability, the waypoint would support continuing Mars exploration and the lunar base with minimal amounts of Earth-launched propellant. The system will produce as much propellant as required for regular cargo and piloted flights to Mars. In addition, the volatile byproducts will support operations on the Moon, near-Earth space, and potential asteroid missions. The development of the technologies necessary to mine and use lunar resources opens up new areas of the inner Solar System.

Early Milestones

Earth-based experimental processes can provide early opportunities to display manufactured products at terrestrial locations. The deployment of prospecting missions at the Apollo 11 site and subsequent deployment of the lunar surface experimental station provide the next set of early milestones. The return to the lunar surface with a robotic processing experiment and the transformation of the lunar regolith into hydrogen, oxygen and other materials for use by returning crews are significant early accomplishments of the Fuels Waypoint.

Enabling Technologies and Processes

The development of meaningful space-based fuel production capability will require significant technology advancement. Systems will have to be reliable and capable of long term remote operation. The selection and development of the fuel production process is critical; experiments and bench scale testing should be done on the Moon before this important decision is made. Mining, regolith transport and processing equipment must be developed. The space transportation infrastructure (refuelable lunar ascent and descent vehicles), cryogenic facilities and the systems to store and transfer fuels must all be designed and tested before large scale fuel production begins.

In addition to these required elements, several technologies would significantly enhance waypoint activities. Precursor missions should be sent to lunar production sites to characterize the surface chemical and mineralogical composition; these missions should include a site rover that carries an evolved gas analyzer for in situ measurements of solar wind volatiles. A variety of lunar surface power system technologies can be investigated, including solar thermal, solar electric, and nuclear power systems. There is no requirement for fast transit of lunar-produced fuel cargo; low thrust cargo vehicles (e.g., nuclear, electric, solar electric and power beaming systems) should be developed to make lunar fuel production more profitable. Telerobotic operations can also greatly ease the work burden on the lunar surface crew and increase efficiency and production.

Enabling Technologies

- **Surface power systems**
- **Cryogenic storage**
- **Telepresence robotics**

This Energy to Earth Waypoint defines a series of activities on the lunar surface to provide energy to the Earth.

Waypoint Objective

The Energy to Earth Waypoint uses lunar resources to provide energy for Earth during the 21st century. Projections for energy demand in the 21st century indicate major shortages of electricity will occur unless new sources are developed, possibly exacerbated by environmental developments. These estimates of future energy requirements (e.g., electricity) vary depending on the assumptions of population growth and energy usage. For example, conservative estimates are that in the 2020 timeframe the

world will require 1,700 GWe of new installed generating capacity. Some estimates of future power needs are an order of magnitude greater. In 2020, six billion people using 3 kWe/person would require 18,000 GWe of new installed capacity. This level of energy use is consistent with a modest industrial standard of living for half the world's projected population. Conservation will help relieve some of the burden, but the requirements for new sources of environmentally acceptable electricity are well established.

Energy Sources

The anticipated sources for gigawatt quantities of electricity are fossil fuels, nuclear fission, nuclear fusion, and

solar energy. Both fossil fuels and nuclear fission suffer from adverse environmental effects. Fossil fuels cause air pollution and increase the carbon dioxide content of the Earth's atmosphere. In addition, fossil fuels are limited in availability and not distributed uniformly, leading to potential supply disruptions and shortages. Fulfilling the projected electricity demand with nuclear fission results in a major commitment to fission power plant construction and possibly breeder fuel cycles which would produce radioactive waste. Technologies to handle high level waste safely are being developed.

Nuclear fusion may become a viable long term source of electricity. Substantial progress has been made in fusion research, suggesting that a

ENERGY TO EARTH

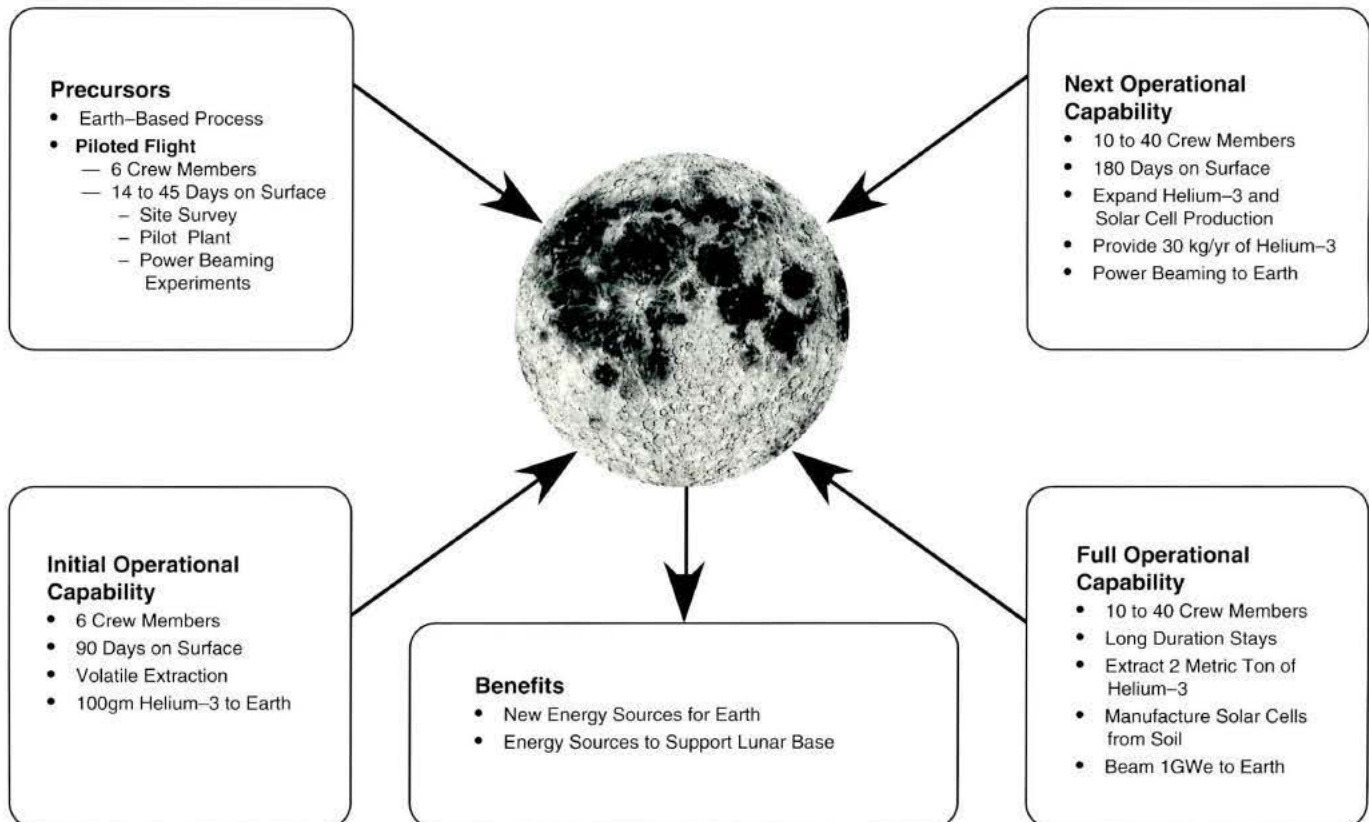

prototype magnetic confinement fusion reactor could be built in the Space Exploration Initiative timeframe. The Deuterium-Tritium nuclear fusion cycle requires radioactive waste disposal similar to fission due to the high neutron fluxes which create radioactive nuclei. The Deuterium-Helium-3 fusion reaction is preferred since it produces significantly lower neutron fluxes. Engineering studies of fusion reactors suggest that a Helium-3 based reactor would be somewhat more difficult to construct than a Deuterium-Tritium reactor but would be safer, more reliable, and more efficient.

Another energy option is the development of extraterrestrial solar energy. On Earth, solar flux suffers from the problem of uneven distribution and availability, and the requirements of power storage to provide continuous electricity. Earth-based solar energy on the scale required has significant environmental consequences due to the required mass and area of collectors. The continental United States has land area with sufficient solar flux to make ground-based solar energy feasible. Many states and many countries do not share this resource evenly. Space offers large areas of continuous solar flux.

Discussion

The Energy to Earth Waypoint considered two scenarios, each using lunar-derived sources. One scenario is to produce Helium-3 for use in Earth-based fusion reactors. The second considers solar energy beamed to Earth from systems constructed from lunar materials.

While Helium-3 is extremely rare on Earth, it is present in extractable concentrations in the lunar regolith (1 part/billion) where it has been deposited by the solar wind. The total recoverable Helium-3 on the lunar surface is estimated to be 1 million metric tons. The magnetic confinement fusion program is moving

toward a demonstration reactor in the 2015 timeframe. If Helium-3 is available at that time, a decision could be made to utilize that fuel cycle, as fusion reactors replace fission and fossil fuel power plants in the post-2020 period. Twenty-five metric tons of Helium-3 could supply the U.S. electricity for one year. Terrestrial sources of Helium-3 are sufficient to support research. The feasibility of providing a large supply of Helium-3 is required prior to commitment to a Deuterium-Helium-3 fusion cycle.

would have minimal impact on the terrestrial environment, utilizing a benign power-beaming system.

This waypoint requires extensive lunar regolith mining and heating, along with propellant, structure, and semiconductor manufacturing on the lunar surface. Cryogenic condensation, separation, liquification, and storage is also required. Lunar transport vehicles would be refueled using volatile byproducts from lunar materials. Methods need to be developed to transport and control large structures in space.

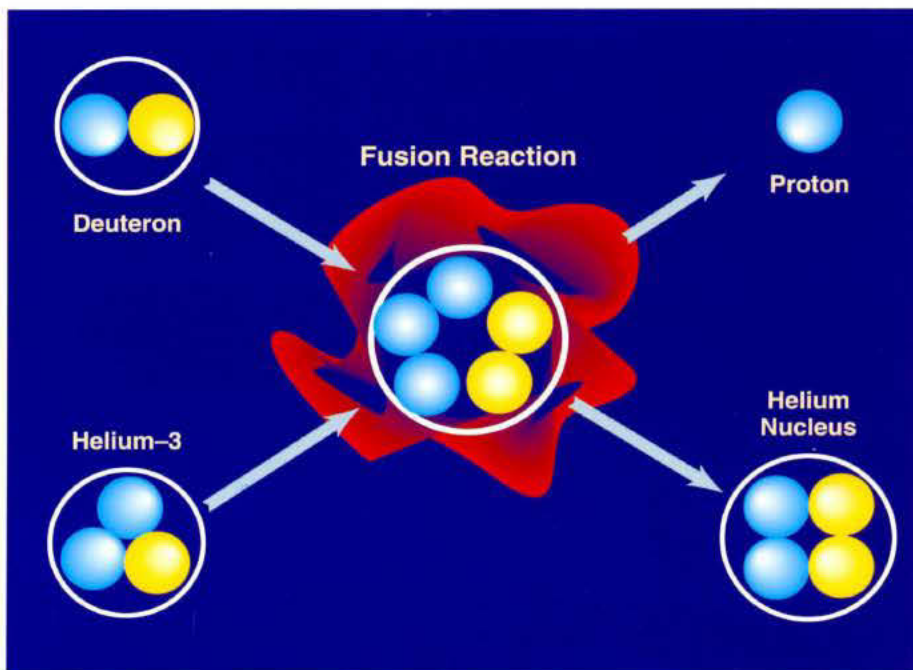

Solar flux in free space or on the lunar surface can be collected and the energy transmitted to ground-based receivers. This concept has the potential of providing globally distributed electricity. Extensive studies of these concepts by NASA and the Department of Energy validate the technical feasibility. Economic benefits have been shown to accrue only if the space segment (collectors, transmitters, structure) are constructed and transported using materials already available in space. Such production

The optimum form of energy transmission (e.g., laser, millimeter wave, microwave) and location of solar collectors have not been determined and may be changed for different applications. Geosynchronous orbit, Lagrange points or the lunar surface are the most likely space-based collecting locations. Some scenarios also require relay systems at these locations.

Precursors

Earth experiments and lunar-based experiments are required, given the scale, scope, and degree of uncertainty of an Energy to Earth Waypoint. The Earth-based experimental phase will design and test processing equipment to produce small quantities of Helium-3 and other volatiles. Solar cells of several square meters and other solid state materials (e.g., transmitter arrays, laser diodes) could be made on Earth from simulated lunar materials.

heat and would be capable of providing useful quantities of volatiles (i.e., oxygen, hydrogen, carbon monoxide, carbon dioxide, methane, and nitrogen) for the lunar habitats. A crew of six (five crew members on the surface, one crew member in orbit) with a supporting habitation infrastructure for crew-tended operations is required at this stage.

Initial Operational Capability

Based on experimental data, an Initial Operational Capability is developed

mass, depending on power supply choices.

Extraction Scenarios

Processing of the lunar surface materials occurs at the central base or in situ with a machine called a regolith heater, traversing the surface. Power is provided via cable or on the regolith heater itself utilizing solar thermal energy. This second option requires the assembly of mirrors and concentrators. The use of waste heat from a nuclear reactor may also prove feasible to power the regolith heater. Many of the collected volatiles which result from the heating process are separated and liquified for storage by passive radiators oriented towards deep space during the lunar night to reject excess heat. While ambient temperatures are sufficient to liquify most of the volatiles, hydrogen and helium require refrigeration and isotope separation to produce Helium-3.

In addition to supplying useful byproducts to the lunar base, the Initial Operational Capability would validate the feasibility of producing Helium-3 from lunar materials and provide the terrestrial fusion research community useful quantities of Helium-3. These byproducts are used in production of propellants, manufacture of solar cells, possible fabrication of solar concentrators and building construction materials. They supplant Earth-derived power systems and allow expansion to the Next Operational Capability.

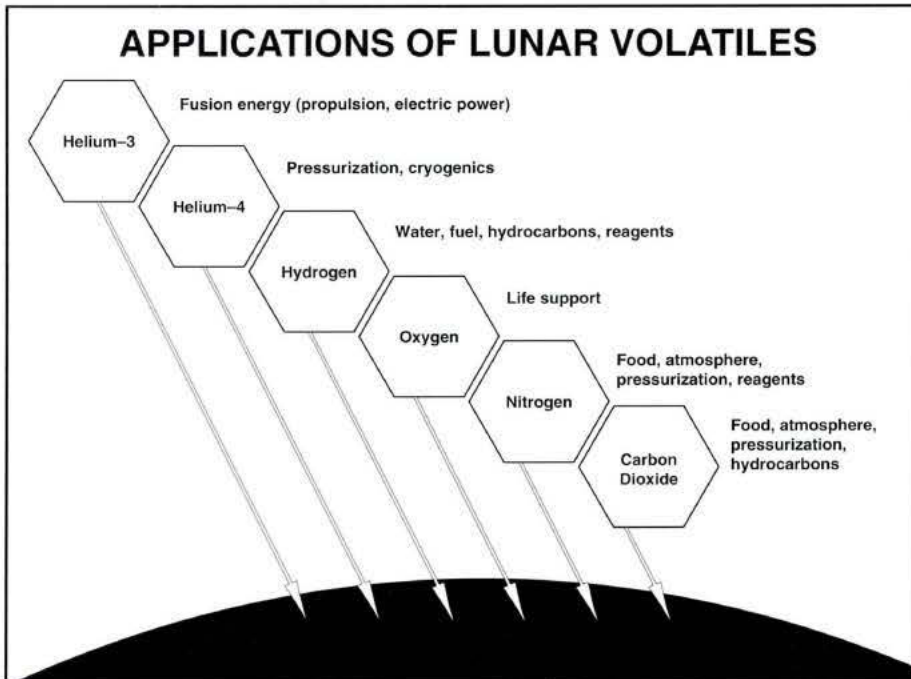

The Apollo 11 and 17 sites can serve as baseline mining sites; however, lunar exploration will identify sites better suited for mining operations. The lunar experimental phase emplaces prototype extraction systems on the Moon to demonstrate feasibility and gain operational experience. Shallow mining depths of 0.1 to 1 m over surface areas as large as 1000 m² would be required. This operation would require several hundred kilowatts of thermal process

which would reduce the requirements for Earth-launched materials for use at the lunar base (e.g., breathing gasses, fuel cell reagents, photovoltaic arrays, propellants) and return small quantities (100gm) of Helium-3 for Earth-based fusion research. Lunar surface areas of square kilometers are processed to a depth of about one meter. Power requirements would be several megawatts with 10 to 20 metric tons emplaced pilot plant

Next Operational Capability

The Next Operational Capability produces sufficient Helium-3 to supply a research fusion reactor with fuel (30 kgs/yr) and demonstrates large scale solar energy transmission in the 2015 to 2020 timeframe. This requires processing 10 to 100 million metric tons of lunar regolith to produce 1,000 to 10,000 metric tons of useful volatiles. Approximately 100 to 200 metric tons

of equipment are required to extract the required amount of Helium-3. An area of lunar surface of roughly 20 km² has to be processed to 1 m depth per year.

The extracted volatiles also support the manufacturing process capable of producing 1 to 10 km² of thin film solar cell substrate annually. These solar energy producing materials are deployed on the lunar surface or launched from the Moon using propellants (e.g., hydrogen and methane) produced in the mining and recovering process. Thin film polymer rolls are routinely produced on Earth in 3 m by 9 km rolls. The lunar environment also offers many features which may be ideal for semiconductor manufacture, including high vacuum. Solar collectors and transmitters then have to be folded and packaged for launch and automated space deployment.

Launch rates required for solar power satellites from the lunar surface depend on the size of the launcher and satellite. For example, a 40 metric ton payload capability would require one launch per week to establish 1 GWe per year generating capacity. These orbital power satellites are based on "thin film" technology such as "vacuum microelectronics" or semiconductor laser systems and could be deployed as separate units while having their energy outputs combined. Such systems are conceptual at this stage but warrant further investigation. Five MWe of power (solar, nuclear, or combination) along with 20 MW of thermal process heat is required to heat the lunar regolith. Based on terrestrial experience, a lunar crew of 10 to 40 is required at the Next Operational Capability.

Power may also be transmitted to Earth or space directly from the lunar surface. If such transmission occurs using microwaves, large areas (100 km across) are required for the lunar transmitters to allow reasonable sizes for multiple Earth receiver sites (10 km across). At least two sites near the

lunar limbs combined with orbiting reflectors provide continuous solar illumination and power delivery during the complete lunar orbital cycle. Laser transmission from the lunar surface at 0.8 micron wavelength requires 10 m diameter optics for 100 m diameter spot size on Earth. Laser transmission offers the advantages of smaller optics but requires laser and optics installation on the Moon and space relay mirrors for continuous coverage at Earth. Another advantage of laser transmission is the use of ground-based photovoltaic materials as receivers. This allows a potential dual use with terrestrial solar electric or even solar thermal systems. Advances must be made in laser efficiency and the manufacture of laser components from lunar materials for this concept to become feasible.

Clouds and weather are more constraining on the higher frequency systems than the microwave systems, but means to mitigate the effects (frequency adjustment, diversity) are feasible. The scale of space-to-Earth power beaming and the technology employed depends on the results of the experimental power beaming developments, terrestrial environmental considerations, and the desirability of lunar surface versus orbital placement. Several different systems may also be employed simultaneously. The success of the Next Operational Capability also allows a decision to be made on whether to pursue a Deuterium-Helium-3 fuel cycle and a full power beaming energy delivery concept.

Full Operational Capability

The Full Operational Capability produces and returns to Earth two metric tons of Helium-3 while continuing to produce 10 GWe installed solar power satellite capacity per year. This provides 10 % of the current U.S. electricity consumption. This necessitates emplacing requisite mining and processing equipment and processing an

additional 200 to 300 km² of lunar surface.

This operation requires a more efficient cargo delivery system to lunar orbit using, for example, power beamed or solar electric orbital transfer vehicles. The power beaming experiments or lunar-produced solar cells may, in fact, first be applied to low thrust orbital transfer vehicles used in the Earth-Moon transportation cycle. The required Earth supplies are made much smaller assuming a manufacturing and repair capability on the Moon.

At Full Operational Capability, in order to return two metric tons of Helium-3 to the Earth, one billion metric tons of lunar regolith have to be processed annually. This requires several hundred megawatts of thermal process heat, mostly collected by solar concentrators constructed from lunar materials.

The Energy to Earth Waypoint has the potential to grow by utilizing indigenous resources at each step to support future operations. The Moon may supply a major portion of Earth's energy needs without damaging the environment. While the payoff is high, there remain numerous technical as well as economic, social and political issues which must be resolved.

Early Milestones

While the Energy to Earth Waypoint is large scale and long term, the early milestones are modest, but nevertheless significant. Success at the early stages makes growth feasible and affordable by utilizing lunar materials. The first milestone is the fabrication of key components in terrestrial laboratory-based experiments utilizing simulated or actual lunar materials. The next milestone is the emplacement of a small experimental resource extraction system on the Moon at the Apollo 11 site or another selected site. This experiment processes small quantities of lunar material robotical-

Enabling Technologies

- **Heavy lift launch vehicle**
- **Planetary surface systems**
 - **Mining machines**
 - **Processing machines**
- **Cryogenic storage**
- **Surface power system**
- **Reusable space transportation systems**

ly, or with the aid of a crew. Such a system is highly automated and continues to operate while untended, building up a considerable stock of materials for the next crew. Current estimates suggest a small experimental plant (e.g., four metric tons) could produce the equivalent of several heavy lift Earth launches in useful materials over the course of several years.

Enabling Technologies

Development of several technologies have a high potential for improving or enhancing lunar exploration and could be used in conjunction with meeting the objectives of other waypoints. As in other waypoints, a heavy lift launch vehicle (150 metric tons, with designed growth to 250 metric tons) is required. Surface systems are a major part of this waypoint and technology studies should be cognizant of the harsh environment (e.g., vacuum, angular abrasive dust) of the lunar surface; equipment may be difficult to use and maintain for any length of time. Machines to mine,

process, and discard large quantities of regolith are needed; these could include tractors, conveyors, and bulldozers. The collected gases from the mined regolith must be gathered, separated, purified, and condensed into cryogens for convenient storage; facilities for liquified products must be available.

These operations require large amounts of power; solar, thermal, electric and nuclear surface power systems may be necessary. Efficiency is greatly increased through the use of methods to recover waste heat from the thermally processed regolith. Transport vehicles, including lunar ascent and descent vehicles, should be reliable and capable of refueling and reuse. Robotic teleoperations can greatly increase productivity and safety for the human inhabitants of the Moon. Power beaming and electric propulsion technologies make transport and delivery of lunar products to space more profitable. Techniques for the control and deployment of large structures in space and on the Moon must also be developed.

The Asteroids Waypoint describes activities that could occur at near-Earth asteroids, including science, exploration, resource survey and preparation for Mars.

Waypoint Objective

A near-Earth asteroid rendezvous could serve as the focus for the first long duration, deep space mission. The mission would provide an operational test of the Mars transfer vehicle and a human crew's ability to conduct deep space exploration.

Discussion

There are currently 140 known near-Earth asteroids, and it is estimated that there may be as many as 5,000.

With this number, there are nine to 10 launch opportunities a year that would require less energy than a lunar mission. The mission opportunities with the current known number occur less frequently, but they are still available in the time frame relevant to a total exploration program. For example, a 390 day round trip mission to the asteroid Orpheus could be accomplished in the 2005 to 2006 window. The energy change required to go to one of these asteroids (a velocity change of approximately 12 km/s) is only 3 km/s more than the energy change required for a lunar mission. A similar duration Mars mission would require significantly more energy.

Asteroid exploration can be effectively performed by trained crew scientists. The detailed geolog-

ic history and present structure of the asteroid may be determined by careful field work and detailed sample collection and documentation by experienced astronaut/geologists. Samples may be collected and studied in their real geologic context. Operating in a zero gravity environment and obtaining the required samples and data is a challenging task which will be greatly aided by the presence of humans.

Asteroids provide a rare opportunity to study condensation of the early solar nebula. The scientific return from obtaining samples of the Solar System's primordial material is very high. For example, some asteroids may have geologically processed materials that represent crust, mantle and core of minor planets. Others may be remnants of extinct comets

ASTEROIDS

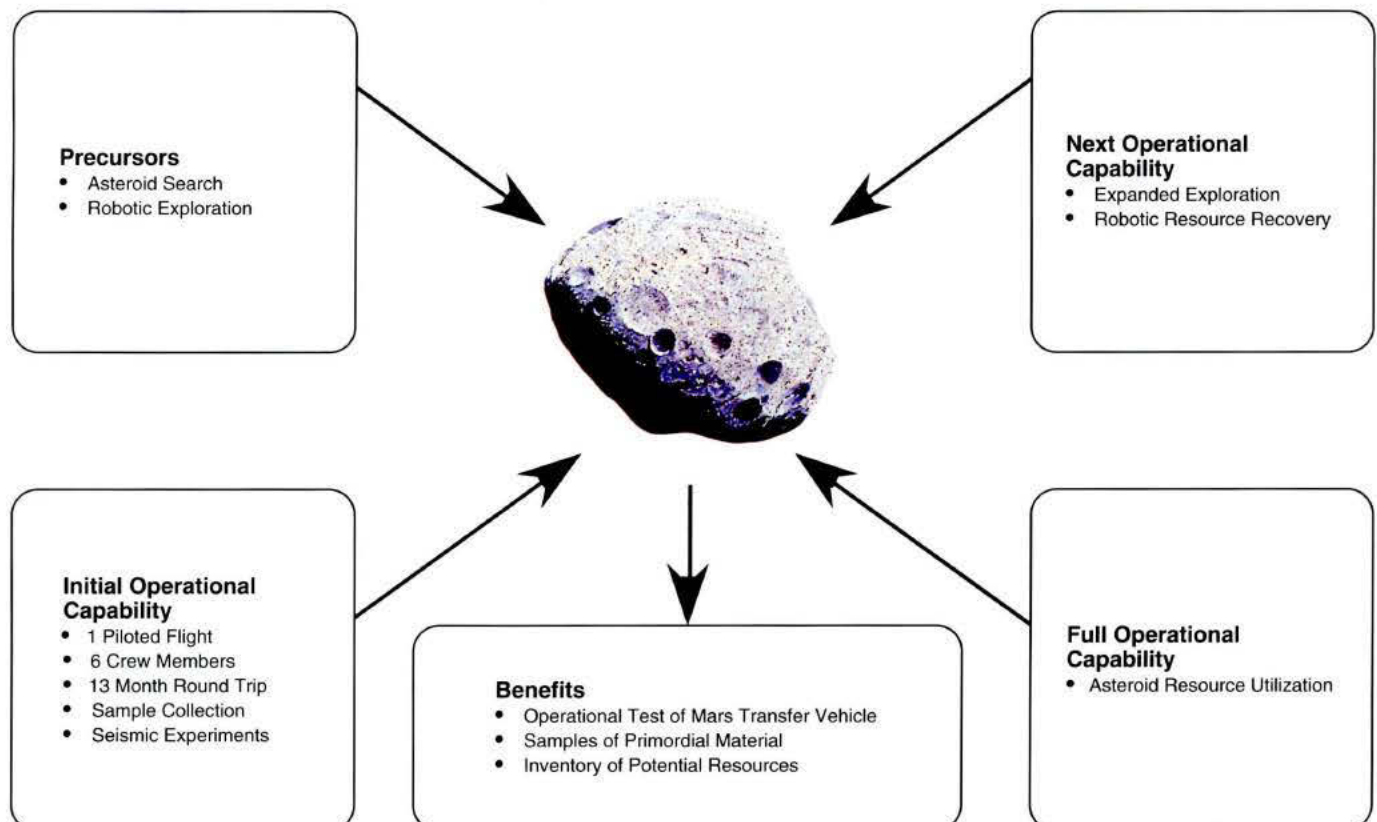

which have been steered into Earth's vicinity by the gravitational fields of the various planets.

A survey of near-Earth asteroids could also provide the first concrete estimate of one of the most promising resource bases available for expanding human presence in space. One thousand near-Earth asteroids with diameters greater than a kilometer could provide the resource base for further scientific investigation. Recoverable volatiles such as water may be abundant on carbonaceous asteroids, since water has already been detected in main belt asteroids.

Future robotic missions to asteroids could mine and process volatiles and metals. The extraction and processing of water from an asteroid will require many of the capabilities developed for fueling a Mars transfer vehicle in orbit.

Precursors

The most productive near-term precursor is an expanded Earth-based survey to find the most favorable mission targets. Newly catalogued near-Earth asteroids are discovered at a rate of 10 to 15 a year. A program to expand this to over 150 a year in the next 15 years would yield over 2,000 new discoveries with a percentage being very favorable for a rendezvous mission.

Characterization

Once the near-Earth asteroids are cataloged, they will be characterized using Earth- and lunar-based instruments. The primary tool for surveying the surface structure and composition of near-Earth asteroids would be a lunar, long-baseline interferometer as described in the Lunar Observation Waypoint. The results would support a scientific investigation of primordial materials to determine the processes that produced the Solar System and would enable the

planning for exploitation of asteroids as a resource base. Early robotic missions could provide imagery, spectroscopy, structural information and sample returns from exploitable asteroids.

Initial Operational Capability

A representative mission would be to have a piloted rendezvous with Orpheus, a carbonaceous chondrite asteroid 500 m in diameter. Using minimum energy, a mission launched in 2005 would have a seven-month outbound trip, a rendezvous of 10 days and a return trip time of five months. The velocity change and complexity of such an asteroid mission is significantly lower than for Mars missions.

The objective of an asteroid rendezvous mission would focus on field studies and in situ resource utilization experiments. Rock samples would be collected from both natural outcrops and crater ejecta. Core extractions from a deep drilling operation would help define the internal structure and potential resource base. Seismic experiments would provide structural information. Experience gained from these activities could be used to assess the potential for robotic resource recovery missions. In addition, a human mission to an asteroid would also allow for the low gravity checkout of resource recovery techniques.

Next Operational Capability

Following the first human exploration, a decision would be made to initiate resource recovery from the specified target or to conduct another exploration mission to a different asteroid. Recovery of resources might be initiated by a robotic low thrust spacecraft which would return volatiles and metals to the Earth-Moon system.

Enabling Technologies

The Asteroid Waypoint requires development of several critical technologies. Robotic survey missions should be equipped with the most advanced remote-sensing instruments available, including charged-coupled device imaging systems, mapping spectrometers and robotic equipment for the surface exploration of an extremely low gravity object (e.g., thrusters for station-keeping; digging tools for sampling). Because a major function of this waypoint is to simulate the Mars mission, the complete Mars transportation system (except lander) should be available to fly the mission. If significant resource utilization of asteroidal materials is contemplated, then excavation, processing and extraction technologies should be studied and developed. These operations could include blasting, rubble collection, milling to a fine grain size, and heating the feedstock for volatile extraction. Rendezvous techniques of large masses in highly elliptical and hyperbolic orbits, station-keeping, and surface operations must also be developed.

Enabling Technologies

- **Rendezvous techniques of large masses**
- **Remote sensors**
 - **Charged-coupled devices**
 - **Spectrometers**
- **Planetary surface equipment**
 - **Excavation**
 - **Extraction**

Mars Waypoint is the series of activities directed at the most expeditious way to accomplish human exploration of Mars.

Waypoint Objectives

This waypoint develops the infrastructure and resources necessary to explore Mars. This includes establishing a transportation system between Mars and Earth, habitats for living on Mars, utilization of Martian resources, and the ability to perform exploration over the entire Martian surface.

Discussion

Mars missions are challenging, but have potentially high benefits. Discovering answers to the questions of life on Mars may provide an essen-

tial understanding of the conditions necessary for the continuation of life on Earth. Should evidence of life or fossilized remains be found on Mars, it would have a profound effect on all traditional scientific concepts of the origin and development of life. Understanding Martian climate and history would provide an additional model for studying Earth's climate, biological history and environment. Understanding the formation and evolution of Mars will provide insight into conditions of the early Solar System; it may also help explain why Solar System planets are so different from each other. Studying the structure and dynamics of Mars' interior will reveal how a planet with no plate tectonics dissipates its internal heat, resulting in refined planetary models of formation and differentiation that

might apply to the Earth. Gravity, topography and morphology will provide clues to Mars' internal structure and the origin of surface materials. Chemistry, mineralogy, quantity and age of surface materials will be used to identify resource quality and distribution. The successful exploration and utilization of natural resources on Mars would serve as a test bed for the eventual expansion of permanent human presence at Mars and beyond.

The strategy selected for this waypoint is based on performing Mars exploration in the most expeditious manner possible, and this involves numerous robotic and human missions. Nuclear propulsion is the baseline propulsive means, with chemical propulsion used as a backup.

MARS EXPLORATION

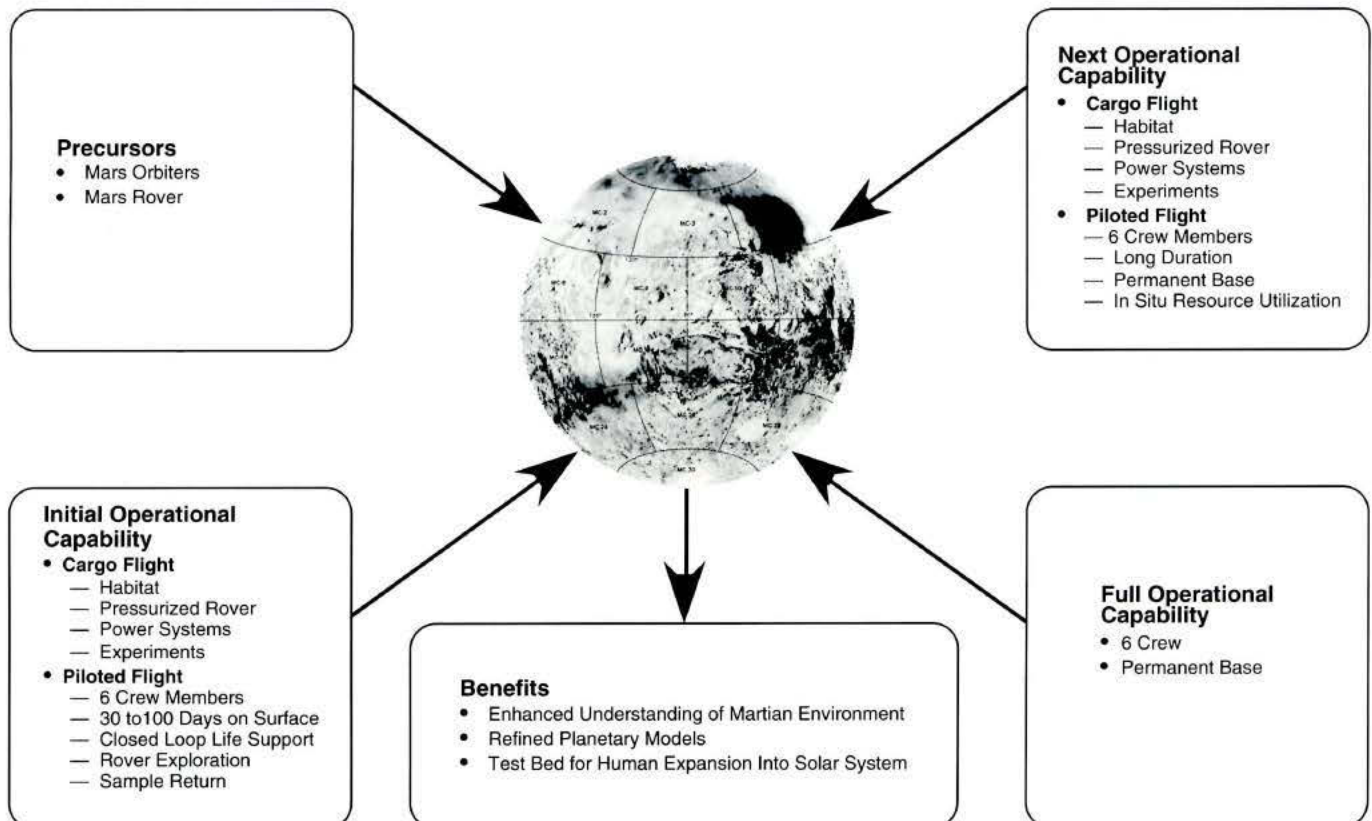

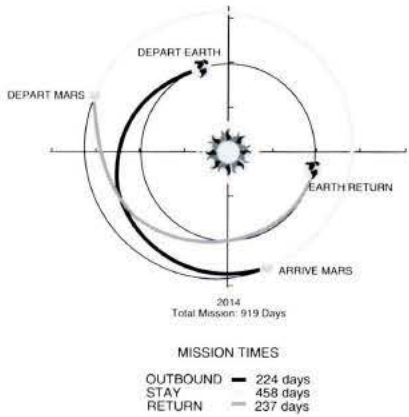
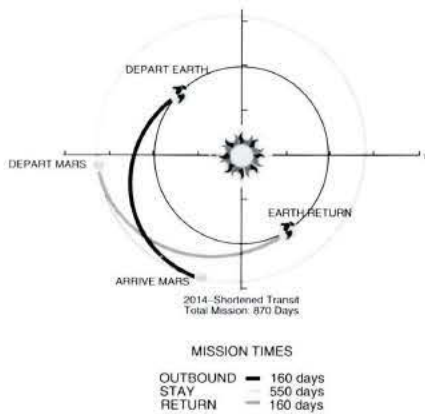
Chemical Propulsion**Nuclear Propulsion**

Going to Mars entails significant human and engineering challenges. Important technological selections were made to reduce risk and cost and maximize benefits.

The missions to Mars are envisioned as separate vehicles for crew and cargo. This would allow the crew to reach Mars with minimum time spent in space while sending the cargo at minimum energy cost. The piloted vehicles would include contingency fuel for return to Earth, but the Mars lander and additional fuel would be sent as part of the cargo vehicle.

The radiation hazard to the astronauts enroute is not well understood. Minimizing travel times to Mars reduces the exposure to radiation, zero gravity physiological effects and psychological health risk to the crew. The initial piloted mission to Mars could be a short duration (500 day class) mission with stays on the planet surface of 30 to 100 days; or it could be a long duration (1,000 day class) mission with stays on the surface of approximately 600 days.

Prior to the mission, a thorough testing program is considered essential to ensure success. The testing would be conducted in a validation and proof-of-concept phase, using the Moon with the Mars transfer vehicle in lunar orbit. From lunar orbit additional testing of ascent/descent vehicles and the measurement of crew performance in partial gravity will be evaluated with excursions to the lunar surface. Surface systems for habitation and transportation are provided for additional evaluation while exploring. This would expand our understanding of long duration space effects to validate equipment and operational concepts.

The choice of a transportation system is the key trade in performance of Mars exploration. For Earth-to-orbit transportation, a heavy lift launch vehicle, with a capability to lift to low Earth orbit 250 metric tons, is needed to minimize the complexity of the

assembly of the Mars mission elements. On-orbit assembly would be further minimized by using modular, automatic docking components with standard interfaces and docking of major elements.

Chemical propulsion has been the mainstay of space transportation systems to date. However, it is limited to a specific impulse performance of approximately 475 seconds. This performance limitation leads to the need for considerable mass in low Earth orbit, as well as restrictions in both launch windows to Mars and time spent in transfer operations. This in turn demands a high launch rate due to the high initial mass in low Earth orbit.

Nuclear thermal propulsion has approximately twice the performance of chemical rockets, with reduced propellant mass requirements. This leads to reduced mass in low Earth orbit, faster trip times (increasing crew safety) and increased launch windows. Though the technology of nuclear rockets was demonstrated in the 1960s with the Rover/Nuclear Engine for Rocket Vehicle Applications program, the United States has no flight experience with this type of propulsion. Development of the nuclear thermal rocket will require preflight testing. During the latter stages of the Rover/Nuclear Engine for Rocket Vehicle Applications program, it was demonstrated that the reactor subsystem of the engines could be operated for sustained periods of time while removing all radioactive nuclei from the exhaust products. The principal challenge in testing an integrated nuclear rocket system is to provide for low ambient back pressure while scrubbing the exhaust products. Preliminary studies have shown that using wind tunnel exhaust techniques (e.g., supersonic diffusers) coupled with exhaust gas cooling and scrubbing could prove feasible for full scale testing. In all cases, development testing of any kind will be performed at an

approved Department of Energy test site. The first flight test of the nuclear rocket could be accomplished on the first cargo flight to Mars.

Nuclear electric propulsion offers 10 times the specific impulse of chemical propulsion. However, because of the heavy power system and the lower thrust levels associated with nuclear electric propulsion, a direct comparison is not that straightforward. Nuclear electric propulsion devices are low thrust, but they thrust continuously throughout the mission to obtain the desired velocities.

Power levels for cargo missions are in the 2 to 5 MWe range. Nuclear electric propulsion provides the lowest mass in low Earth orbit for minimum energy trips, but requires significantly longer trip times.

- 1) Nuclear thermal propulsion requires about half the mass in low Earth orbit compared to chemical propulsion for similar missions and launch windows
- 2) Nuclear thermal propulsion requires about 500 to 600 metric tons for long duration missions; short duration missions will require 600 to 700 metric tons in the selected years
- 3) Chemical propulsion requires 1,100 to 1,600 metric tons for long duration missions; short duration missions will require 1,300 to 2,000 metric tons, even in the selected years (2008, 2014, 2016, 2018, 2020)

Trip times are approximately 400 days for long duration missions, although use of nuclear thermal rockets could decrease these times to 320 days round trip for a modest increase in propellant mass. For short duration nuclear propulsion missions, surface stay times can be extended from 30 days to 100 days at a penalty of about 100 to 200 metric tons in favorable years. Higher performance nuclear

rockets (engine specific impulse = 1,250 seconds) can save approximately 200 metric tons per mission.

The Mars transfer vehicle will use propulsive braking for orbital insertion and direct entry for Earth return in a separate return crew module. The aerobraking concept was found to have too many unknowns and unresolved issues to be considered for a baseline, due to such factors as:

- Complexity of on-orbit assembly
- Structural integrity verification processes
- Incompatibility with nuclear thermal rocket propulsion
- Incompatibility with high entry velocities
- Spacecraft configuration limitations
- Abort options
- Research and development costs
- Unknown Martian atmospheric conditions
- Sensitivity to mass distribution

The payload mass would be split among several vehicles, with the return vehicle from Mars made as light as possible. Most of the mass would be carried on the cargo flights, with return fuel being the largest single item of cargo. Sufficient fuel would be carried in the crew transfer vehicle to ensure that a return trip with a minimum energy trajectory could be accomplished if rendezvous fails with the cargo flight carrying the return fuel.

Communications, navigation and information management systems are critical factors for conducting human, autonomous operations at Mars. Operationally there is approximately a seven to 40 minute communications

delay due to the round trip distances radio transmissions must travel. This constraint precludes Earth-based, real time command and control, so functions such as extravehicular activity control, guidance, acquisition and tracking must be performed in situ. The Mars-based control center will be supported by an information management system that allows astronauts the ability to conduct operations without having to actively monitor or control mission element systems.

Communications with Earth and between other mission elements will be supported by a constellation of relay satellites orbiting Mars and a series of Earth ground stations. The radio frequency bands selected to sustain the high data rates required of this mission are Ka-band (27 to 40 GHz) for the Earth-Mars uplink, and UHF for local emergency and crew communications. It should be noted that the feasibility exists to use high frequencies for inter-element surface communications if the Martian ionosphere supports sky wave transmissions.

Navigation for mission elements will be supported primarily by an Earth-based system (radiometrics), and assisted by onboard electronic aids for critical operations, such as orbit insertion, landing, rendezvous and docking. Mission operations requirements for the later missions may require a navigation system to provide the desired resolution, with positional accuracies approaching 100 m if using a Martian global positioning system.

The minimum communication capability for the first two Mars missions is for the crew on the Martian surface to be able to frequently and predictably communicate with the Earth either directly or by relay through the vehicle orbiting Mars.

An integrated logistics support system could be required for resupply and spares for the later missions.

Initial Operational Capability

The first piloted mission will establish the Initial Operational Capability and include a demonstration of:

- Communication/navigation systems capability
- Human transportation system to Mars and return
- Habitat and life support system on the surface
- Initial scientific experiments on the surface

The concept calls for emplacing as much mission material as possible in Mars orbit and on the Martian surface (remotely verified to ensure that all systems are functional) to allow turnkey operations by the crew when they arrive. The crew will be provided with the tools and equipment necessary to perform a wide variety of operations.

The mission would be performed using separate cargo and crew vehicles. Earth orbit operations will use automated rendezvous/docking of standard modules, minimizing on-orbit operations. Cargo missions for the Mars surface and orbit will be delivered in the most energy efficient way. The cargo for the surface includes the habitat, pressurized rover, unloader, power systems, exploration packages and in situ resource experiments. Mars orbit cargo includes the stages for returning to Earth and the descent/ascent vehicle. The piloted mission would be flown with minimum transit times to reduce crew exposure to high radiation and zero gravity. Sufficient fuel and supplies would be carried by the piloted vehicle to provide an abort mode for return to Earth.

The primary mission option would be a short duration (30 to 100 days) stay performing surface exploration. Command and control will reside

with the six-person crew. All crew members will be on the surface in order to minimize effects of zero gravity during the long trans-Mars and trans-Earth trips. Prior to Mars orbit insertion, crew members will begin telerobotic exploration of the planet. This will help characterize the proposed and alternate landing sites in addition to expanding basic exploration. Should surface conditions be unfavorable for a landing, because of adverse weather conditions, telerobotic exploration will continue from Mars orbit.

The lander transports all of the astronauts and their equipment to the surface and returns the astronauts and Martian samples to orbit. Only short term life support would not be required, as the lander will not be used as a surface habitat.

Part of this support system would be a reusable habitat separate from the lander. The habitat has a closed loop life support system, except for food, and is capable of long term use with resupply. It is modular in design, supports a crew of at least six and contains living quarters and work space. It is capable of automatic setup and checkout before the astronauts arrive.

A pressurized rover will provide mobility for the crew and enable overnight trips to a 50 km radius for the initial flight, expanding to 100 km for subsequent flights. Several days of life support will be available from the rover. A major increase in space suit capability is required. Improvements over current suits are needed to reduce weight and provide greater increases in flexibility, reliability and life support capability.

The arrival of humans on the surface of Mars opens new vistas of scientific accomplishment. Field studies become possible when human powers of observation and thought are present, both through the actual presence of humans and by extension through telepresence. The crew can systematically examine, measure and sample exposed deposits, map their extent

and continuity, and search rock exposures for possible fossil remains. The field work proceeds on both a contingency and an iterative basis. In the first case, the crew's specific field tasks are actively directed by significant findings in the field; these decisions are made by the field crew in real time. In the second case, the crew needs the ability to revisit, re-examine, and resample previously explored field sites, both to supplement new knowledge and to integrate data into new contexts derived from the evolving conceptual framework. Such work requires insight and geological experience. Traverses in the pressurized rover are to sites identified from orbital imagery and the prior surface rover reconnaissance. A crew of two or three travels up to 50 km away from the lander to examine key geological sites, collect carefully controlled samples, deploy instrument packages, and decipher and understand the complex geology of the region adjacent to the landing site.

Although general routes are planned and major field sites identified in advance, the unique opportunity of human travel over the Martian surface permits traverse routes and plans to be modified in real time. This capability is the cornerstone of conducting true field exploration, and the maximum possible latitude for operational changes are granted to the crew during the Mars visit. In this way, significant and unexpected discoveries are most likely to be made and, as importantly, to be followed up with additional field work.

Hundreds of kilowatts of electric power would be needed for the Martian base, with an emergency backup system for the habitat capable of operating for at least six months.

Next Operational Capability

The Next Operational Capability would be established by repeating the mission to two other sites or a revisit of the original one answering Mars

scientific questions. A significant improvement in capability would be accomplished with a permanent base and by the use of in situ resources (hydrogen, water, methane and oxygen) for life support and rovers. The traverse radius of the pressurized rover increases from 50 to 100 km.

Early Milestones

In preparation for the long human flights to Mars, all components of the mission would need to be validated. This will provide confidence that the mission could be performed in a safe and reliable manner and that the operational concepts are valid. The Moon offers the only partial gravity environment necessary for Mars mission testing.

The Preparation for Mars Waypoint uses orbital research facilities and the Moon for validation experiments; allows secondary activity involving exploration, observations, learning to live on the Moon and developing lunar in situ resources; and meets the President's goal of going back to the Moon to stay. The main objective of validating systems for Mars would not be compromised. For example, the habitat that is designed for Mars would be as close to a Mars prototype as possible when tested on the Moon. The same could be done with the Mars descent vehicle.

Mars precursors should be designed to reduce the risk for human missions. In an aggressive plan, the schedule for these activities would be very tight due to the fact that 2008 is the first reasonable launch window for a piloted mission.

Enabling Technologies

The Mars mission needs several critical technologies for its successful completion. As in other waypoints, a heavy lift launch capability is the first requirement; at least 150 metric tons payload capacity with design growth to 250 metric tons is necessary. Nuclear thermal propulsion gives the maximum amounts of leveraging and should be developed. Automated rendezvous and docking technology will facilitate space operations for the lunar and Martian trips. For the long duration in space required for trips to Mars, long duration cryogenic storage, closure of life support system loops, and better knowledge of the space radiation environment and zero gravity and its effects on humans are also needed. To ensure that humans can do productive work when they reach Mars, flexible and maneuverable extravehicular activity suits and robotic telepresence technologies should be aggressively pursued.

Enabling Technologies

- **A heavy lift launch capability of greater than 150 tons with designed growth to 250 metric tons**
- **The development of nuclear thermal propulsion**
- **Automated rendezvous/docking capability**
- **Long-life (5 year) cryogenic storage systems**
- **Knowledge of radiation and zero gravity effects on humans**
- **Highly maneuverable low pressure extravehicular activity suits**
- **Telerobotic devices for setting up facilities, servicing, and exploration**
- **Surface power of hundreds of kilowatts with backup emergency life support**
- **A closed life support system (except for food)**
- **Nuclear electric propulsion would be considered a great enhancement for the cargo missions**

THE OUTREACH PROCESS

The Outreach Program was a nationwide solicitation for innovative ideas. The program was a result of the Vice President's directive in December 1989 "to cast a net widely" to collect these ideas.

Solicitation took several forms. The NASA Administrator sent individual letters directly to universities, professional societies and associations asking for their suggestions. There was also an announcement in the Commerce Business Daily.

NASA

During the Synthesis Group orientation phase, NASA organized an extensive and comprehensive series of tutorials to provide information to members of the group. These tutorials were presented by knowledgeable experts in the varied disciplines that

will support the Space Exploration Initiative. NASA also gave the Synthesis Group the benefit of its experience by discussing the complexities associated with the development of architectures.

NASA played a major role in conducting studies. Of particular note was the mission design work led by the late Ed Lineberry. His particular contributions were key to the Synthesis Group's understanding of the complexity of and constraints imposed by Mars missions.

The RAND Corporation

The RAND Corporation solicited, received and conducted an initial screening and analysis of ideas from the public. RAND developed an information packet, staffed an 800-telephone number, produced and

mailed packets, and processed "intent to respond" forms. They then contracted with an independent accounting firm to receive and log submittals. The process is shown in Figure 1. The public was solicited by a variety of advertising methods. Resulting inquiries via mail or the 800-telephone number were handled by RAND. When the individual submittals arrived, they were initially processed by Peat Marwick Main & Company. All submittals were assigned a sequential log number and examined to ensure there were no classified or proprietary markings. RAND was asked not to handle classified submittals and proprietary ideas were discouraged.

The originators were instructed to describe their ideas in a two-page summary and were given the option to augment this summary with a

Figure 1

RAND'S OUTREACH PROCESS

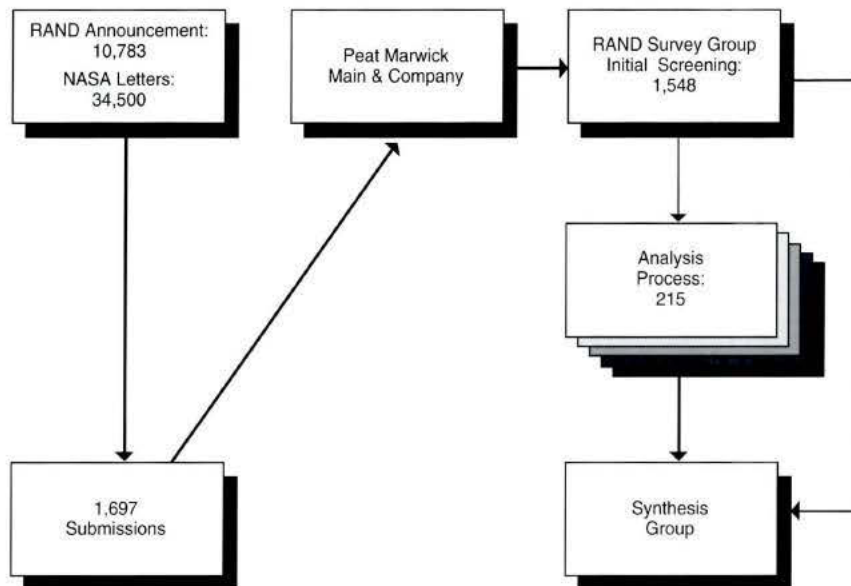

10-page background paper. These administrative restrictions were designed to preclude the submittals of books and manuscripts, as well as to ensure that all ideas would get equal review by RAND's technical panels. In practice, ideas were not rejected based upon format. The initiator was requested to place the idea into one of 11 technical categories, and these areas were reviewed by panels of experts from RAND. The categories were:

- Mission Concepts and Architectures
- System Design and Analysis
- Space Transportation Launch Vehicles and Propulsion
- Space and Surface Power
- Life Support Systems, Space Medicine and Biology and Human Factors
- Space Processing, Manufacturing and Construction
- Structures, Materials and Mechanisms
- Communications, Telemetry and Sensing
- Automation, Robotics and Teleoperators
- Information Systems
- Ground Support, Simulation and Testing
- Other

The inputs were initially screened by the panels. This screening process was designed to assure relative insensitivity to the quantity of submissions in any given area and to select the best of the ideas for further analysis. The review process was such that each reviewer worked independently to establish a numerical score against established criteria. The scores were later compared by the panel chairmen, and if there were disparities, they were discussed in order to determine the reasons for different ratings.

To establish scoring criteria, the panels established five principal

attributes. These were utility/usefulness, feasibility/risk, safety, innovativeness and relative cost. For each of these attributes, each panel tailored individual criteria for the scoring. The five attributes were also given weights for each of the panels. Each idea was scored against each of the attributes using a scale of 1 to 5. With the individual scores and weights of the attributes, values were computed for each submission.

Demographics of Submittals

Nearly 11,000 information packets were mailed to individuals based upon letters and calls to RAND. An additional 34,500 were mailed by NASA. These mailings resulted in 1,697 individual submissions logged by Peat Marwick Main and Co.; 149 were eliminated as being invalid, and 1,548 were provided to RAND. A submittal was determined to be invalid if it were proprietary, classified or if no information were supplied with the cover sheet. Of the submittals, the vast majority (63%) were from individuals. Twenty-two percent were from industry. Only 5% were from educational institutions. Many of the individual submittals did give university or college addresses, but were marked by the originator as private submittals.

There was broad geographical response, with all states except Alaska, Arkansas and Wyoming represented. Even though the outreach was technically a national exercise, there were submittals from Argentina, Australia, Canada, Israel and Scotland. A preponderance of the submittals, however, were from three states: California (26%), Texas (9%), and Florida (5%); 121 submittals included NASA addresses associated with the respondent. The largest single number of ideas were in the transportation area (20%). Next were architectures, with 18%. Ten percent were in the life support area, and 9% were power related. The fewest submittals were in the information systems area, with slightly more than 1%.

Resulting Analysis

The ideas submitted show innovative but not necessarily revolutionary ideas. There were ideas from people who did not have a formal technical background, but wanted to show their interest and support. This group included young children who could someday participate in the Space Exploration program. However, the submissions did contain new implications for old ideas in the context of the Space Exploration Initiative. The submissions supported a wide range of Space Exploration Initiative mission concepts and architectures.

American Institute of Aeronautics & Astronautics

The American Institute of Aeronautics and Astronautics solicited from their own individual members new technical ideas or approaches applicable to the Space Exploration Initiative (Figure 2). The resulting submissions were assessed for their value in reducing the costs or risks of human flight beyond low Earth orbit or the time needed to do so; or enabling the accomplishment of more useful space exploration objectives with the available resources. The American Institute of Aeronautics and Astronautics solicited ideas via advertising as well as direct mail to 44,000 members. These resulted in 542 responses which were then evaluated by nearly 100 volunteer Technical Committee members assembled into five working groups. These were:

- Architecture and Systems
- Transportation Technologies
- Human Support Technologies
- Planetary Surface Technologies
- Support Facilities and Systems

Conclusions and Recommendations

Each of the five working groups established its own recommendations or conclusions, which are described in

detail in a separately published American Institute of Aeronautics and Astronautics report. In addition, there were several general recommendations that are applicable to the Space Exploration Initiative program:

- 1) The solicitation and evaluation of ideas should be continued and expanded to include groups outside the classical aerospace community.
- 2) Several architectures from the Synthesis Group should be studied in detail.
- 3) Key technologies should be addressed now.
- 4) The reason for space exploration should be developed to ensure program focus toward those goals.

- 5) The public, press and Congress should be told about the risks associated with all aspects of the endeavor.
- 6) Management structures must be defined to accomplish the selected architectures and technology development.
- 7) A program plan must be developed with clear milestones and clear decision points.

Federal Research Review

The Department of Defense. The Secretary of Defense was asked by NASA to provide recommendations to the Synthesis Group. Inputs were obtained throughout the services, showing broad participation from the Army, Marine Corps, Navy, Air

Force, Department of Defense agencies, the Joint Staff, the Strategic Defense Initiative, U.S. Space Command, and other components, including Department of Defense sponsored contractors. The recommendations covered system design and analysis, space transportation, space and surface power, life support systems, human factors, space processing, structures, materials, mechanisms, communications, remote sensing, automation and robotics, information systems, ground support, simulation and testing. Through this process, the Secretary of Defense identified technologies applicable to the Space Exploration Initiative.

The Department of Defense set up a Space Exploration Initiative task force. The task force mandated multi-organizational participation and separated into four panels: systems and architectures, transportation, technologies, and surface operations.

The Department of Defense presented three major conclusions:

- 1) Quantitative assessments of technology contributions are limited by uncertainties in the Space Exploration Initiative architecture.
- 2) Current Department of Defense technologies in chemical propulsion, communications, advanced computers and power offer the most to the Space Exploration Initiative before the year 2000. Further, materials and manufacturing developments underlie these technologies.
- 3) Innovative technologies in non-chemical propulsion, information, robotics and low cost Earth to low Earth orbit have potential after the year 2000.

AMERICAN INSTITUTE OF AERONAUTICS AND ASTRONAUTICS OUTREACH PROCESS

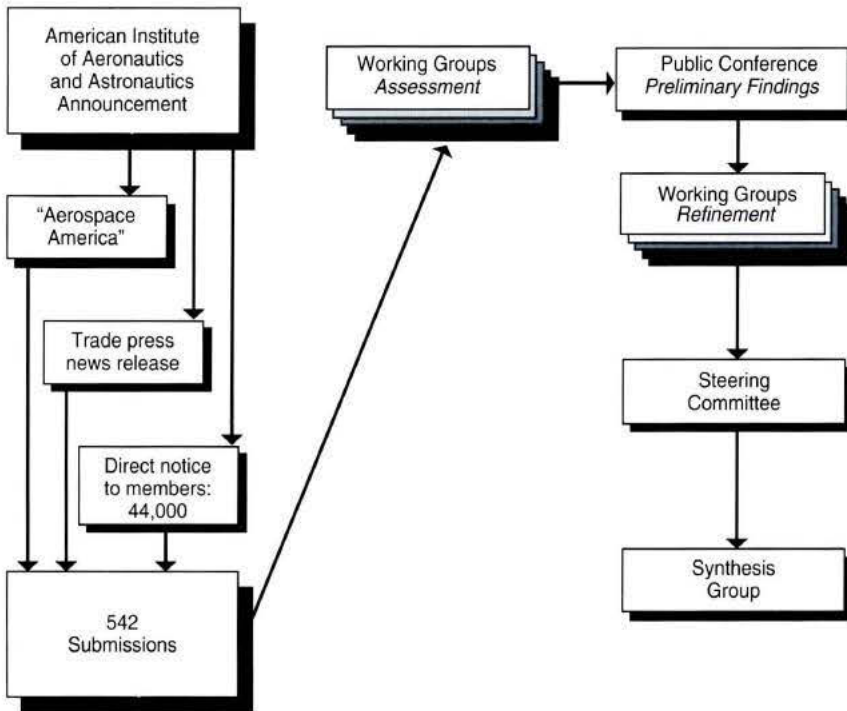

Figure 2

In addition to these conclusions, the Department of Defense identified the following findings:

- 1) Extensive Department of Defense experience has great benefit to the Space Exploration Initiative, specifically in the areas of space launch and operations, logistics support and surface facilities and operations.
- 2) Department of Defense technologies in propulsion, robotics, information processing and power have a major application to the Space Exploration Initiative.
- 3) Many features of the Department of Defense acquisition management system can enhance the Space Exploration Initiative.
- 4) The Department of Defense launch road map and the Space Exploration Initiative launch requirements are consistent.
- 5) Mutual leverage is provided by the space launch infrastructure.
- 6) Operability requirements are similar.
- 7) Department of Defense space systems have many potential applications to the Space Exploration Initiative.
- 8) Upgrades of Department of Defense space systems can enhance the Space Exploration Initiative and would also have tremendous benefits to the Department of Defense.

In light of these findings, the Department of Defense specifically recommended:

- 1) Develop a national launch strategy combining Department of

Defense and Space Exploration Initiative requirements.

- 2) Conduct a detailed evaluation of the application of selected Department of Defense space systems.
- 3) Consider the National Test Bed as a model for an independent test and validation facility.
- 4) Use the Department of Defense engineering and construction expertise in the Space Exploration Initiative.
- 5) Develop joint technology plans for each architecture.
- 6) Establish a national program organization with Department of Defense involvement.

The Department of Energy. Recommendations were also solicited from all the federal laboratories. The Department of Energy presented its views on power, propulsion, power beaming, resource utilization, robotics, computers, sensors, Helium-3, life support, safety, materials, debris shielding and ways that its radiation facilities can contribute to the Space Exploration Initiative.

In support of the goals and objectives of America's Space Exploration Initiative, the Department of Energy concluded:

- 1) The Space Exploration Initiative should be a broad-based, inter-agency effort that harnesses the nation's intellectual prowess and industrial might to explore the universe as well as to benefit humans on Earth. Particular attention should be paid to preserving the pristine environment of the Moon and Mars, enhancing U.S. competitiveness throughout the world, solving global problems and

inspiring the nation's young people.

- 2) The Department of Energy and, in particular, its National Laboratories, have unique energy and energy-related expertise, capabilities and facilities that can directly support the Initiative. This includes over 30 years of experience in remote sensing in and from space; nuclear power and propulsion systems; non-nuclear energy systems; and advanced technology development in robotics, materials, manufacturing, life sciences and high performance computing applicable to the Initiative.

The Department of Energy can make major contributions to this national Initiative:

- 1) In designing, developing and testing space nuclear power and propulsion systems.
- 2) In exploring new energy production, transmission, conditioning and storage techniques for use in and from space and on the lunar and Martian surfaces.
- 3) In developing space-qualified remote sensing capabilities for exploration of the Moon, Mars and other planetary bodies.
- 4) In conducting research and development on radiation effects and limits and shielding for humans and equipment in space.
- 5) In applying technology research conducted in advanced materials, optoelectronics, robotics, high performance computing, sensors, and biomedicine to manufacture ultra-reliable space

systems for exploration of the Moon and Mars.

- 6) In capitalizing on national educational efforts underway in the Department to encourage broader interest in space sciences, mathematics and engineering.

The Department of Energy made the following specific recommendations concerning the Space Exploration Initiative:

- 1) The government should use existing interagency coordination mechanisms within the Executive Branch, such as the Federal Coordinating Council on Science, Engineering and Technology, to establish Space Exploration Initiative goals and objectives; to assess architectural options; to validate program and budget priorities; and to coordinate and review interdepartmental implementation. NASA should lead the effort with broad intergovernmental and private and public sector participation.
- 2) NASA, the Department of Energy and the Department of Defense should jointly develop nuclear power and nuclear propulsion systems, with the Department of Energy leading the design and testing phases.
- 3) The Department of Energy should coordinate U.S. long-term, high-risk and high-payoff research and development efforts in energy and energy-related areas such as high efficiency solar cells, high temperature superconductors, and advanced non-nuclear propulsion techniques.

- 4) The Department of Energy lead a national program on radiation life sciences.
- 5) The Department of Energy and the Department of Defense should apply state-of-the-art satellite technology to extraterrestrial space missions.
- 6) The Department of Energy should support basic and applied research efforts of the civil and commercial space sectors in the areas of resource utilization, non-nuclear energy, environmental assessment and monitoring, human health/ life science, manufacturing, and high performance computing.

The Department of the Interior. Recommendations were also presented by the Department of Interior in response to the solicitation made to all federal laboratories. Presentations were made by the U.S. Geological Survey and the Bureau of Mines.

The U.S. Geological Survey outlined their diverse science capabilities in the following areas:

- 1) Geology
- 2) Cartography
- 3) Planetology
- 4) Geophysics
- 5) Photogrammetry/topography
- 6) Image processing

They emphasized their long term cooperation with NASA and the Department of Energy, their major involvement in the Apollo program, and their facilities dedicated to support lunar and planetary missions in Flagstaff, Arizona.

The U.S. Geological Survey viewed their possible roles in support of the Space Exploration Initiative to include the following:

- 1) Strategic planning: science strategy, environmental factors

(terrain analysis, soil properties), prospecting for resources

- 2) Mission design (robotic and human): definition of goals and requirements, instrument development, mission profile development, and science and engineering assessment
- 3) Development of field geology techniques: mission simulation, astronaut training, and tool development
- 4) Cartographic/photogrammetric support

The Bureau of Mines presented a concept for Indigenous Space Materials Utilization. Their proposed concept was based upon near term small-scale technology demonstrations. Their recommendations included the following:

- 1) Evaluate the proposed concept for possible utilization to support Space Exploration Initiative architectures.
- 2) Emphasize small scale systems with immediate product applications.

Aerospace Industries Association

The Aerospace Industries Association was requested to solicit and coordinate recommendations from its membership. The following member companies made presentations:

- 1) Bechtel Corporation
- 2) Boeing Corporation
- 3) General Dynamics Corporation
- 4) General Electric
- 5) Grumman Corporation
- 6) Honeywell Incorporated
- 7) Hughes Aircraft Company
- 8) IBM Corporation
- 9) Lockheed Corporation
- 10) Martin Marietta Corporation

- 11) McDonnell Douglas Corporation
- 12) Rockwell International
- 13) Teledyne Incorporated
- 14) Texas Instruments Corporation
- 15) Thiokol Corporation
- 16) TRW Corporation
- 17) United Technologies Corporation
- 18) Westinghouse Corporation

- 1) American Telephone and Telegraph Company, Bell Laboratories
- 2) Eagle Engineering Corporation
- 3) Lunar Exploration Incorporated
- 4) Ocean Systems Engineering
- 5) Science Applications International Corporation
- 6) Talarian

Synthesis Group Process

All of the submittals were evaluated by the Synthesis Group and will be archived by NASA. Figure 3 depicts the synthesis process.

Additional Industry Presentations

Additional companies contacted the Synthesis Group to provide recommendations over and above the Aerospace Industries Association. They included the following:

Individual Recommendations

Recommendations were provided by individuals directly to the Synthesis Group. These were presented as written proposals as well as formal presentations. Every effort was made to insure their consideration in the Synthesis process. These individuals are identified in the Appendix.

Figure 3

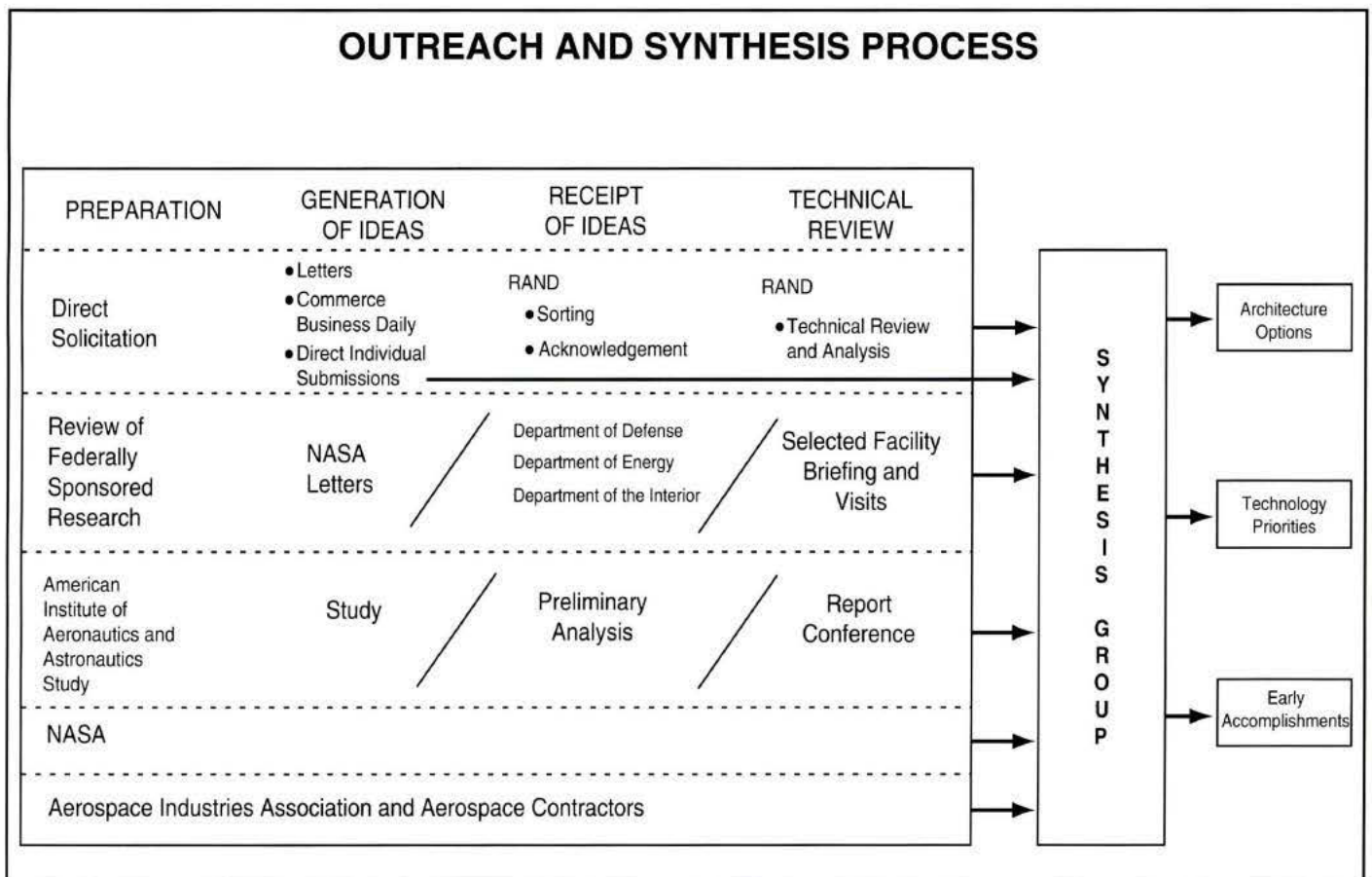

OUTREACH PARTICIPANTS

WILLIAM H AAROE • CARL J ABBOTT • ROSE ADLER • AEROSPACE R&D POLICY COMMITTEE • JAMES R AIKEN • VAL ALBERT • JOHN R. ALBRECHT • MICHAEL B ALBRIGHT • JOHN M ALDERSON • BUZZ ALDRIN • JONATHAN COOPER ALLEN • VAN S ALLEN • ROSEMARY B ALTHOFF • ALLEN AMABISCA • JAMES M AMMANN • GREGORY H AMPAGOOMIAN • KENT L ANDERSON • CHARLES MELVIN ANDREWS • ELIZABETH ANN ANDREWS • VICTOR J ANSELMO • STEVEN ANTENACCI • JEFFREY ANTOL • LORI AP' THORP • CREIGHTON AQUIN • V H ARETI • RONALD C ARKIN • JOHN ARVAN • KENNETH L ATKINS • DEBORA L AVILA • ANTHONY AVVINTO • GEORGE BABYAK • DONALD F BAER • JOHN BAJAK • DAVID BAKER • DWIGHT I BAKER • KAREN BAKER • THOMAS A BAKER • LOUIS A P BALAZS • W JOHN BALLANTYNE • S G BANKOFF • RANDALL L BARBOUR • CHRISTINE BARKER • DAVID BARKER • QUINTON BARKER • WILLIAM K BARKER • ERIC JOHN BARNETT • MICHAEL A BARONE • DAVID JOHN BARRETT • LUCY LEE BASCOM • E BASQUES • OLLIE GENE BASS • BOBBY BAUM • LARRY BAUM • SCOTT G BEACH • RICHARD BECHTOLD • T ANDREW BECK • DAVID W BECKES • RAYMOND DE CASTRO BELGRAVE • HAYM BENAROYA • JAMES A BENET • BOONSIENG BENSAUTHRIT • SCOTT W BENSON • DWAIN T BENTON • DENIS E BERGERON • NANCY BERNARD • DENNIS BERUBE • RONALD L BESSER • D K BHADRA • JAMES I BIBB • PETER BIERSTAKER • DAVID BINDNER • MORRIS BIRNBAUM • GIL BISHOP • ERIK BJARNAR • HAROLD S BLACKMAN • GEORGES BLAHA • DAVID BLANTON • PATRICK BLONG • JOHN HAYES BLOOMER • MASSE BLOOMFIELD • JON BOBBIT • KACY BOCCUMINI • PARTICK E BOCK • FORREST R BOGARD • LEE BOGART • MARVIN R BOHNERT • DENNIS E BOHNSACK • RAYMOND H BOLDUC • BOB BORING • PHILLIP C BORJA • STUART W BOWEN • MICHAEL J BOWERS • K BOWERSOX • JEFFREY V BOWLES • MARK M BRAUER • COURT BRAUNELL • MORTON A BREIER • LARRY BRLL • JOHN WESLEY BROUGHTON • ROBERT A BROWN • STANLEY K BROWN • ROBERT BROWN • ALASTAIR BROWNE • A. BROWNE • JAY BROWNFIELD • DONALD LOUIS BUCHANAN • ROBERT BUCKLEY • DAVID BUDEN • S PAUL BUENEA • JOSEPH W BUFFINGTON • STEPHEN M BULL JR. • KENNETH F BUMGARDNER • FRIEDRICH O VON BUN • S PAUL BUNEA • ROBERT CHARLES BURCK JR. • EDWARD W BURKE • JAMES D BURKE • DANIEL J BURNS • RODNEY L BURTON • DAVID L CAFARO JR. • MARK A CALLAHAN • GORDON C CAMPBELL • JAMES LYNESS CAMPBELL • PAUL D CAMPBELL • WILLIAM J CAMPBELL • ANTONIO SERNA CANDELARIA • MARGARET R CARINI • F CARLSON • DEAN S CARPENTER • SCOTT CARPENTER • ROBYN L CARRASQUILLO • JOSEPH A CARROLL • GEORGE T CARSON • ROBERT L CARSON • WILLIAM A CASE • FRANK ANDREW CATAPANO • F CHANG-DIAZ • JOHN DOUGLAS CHARLTON • TOY J CHEE • DON CHENEVERT JR. • E JAMES CHERN • BORIS A CHERNICK • KENNETH J CHEVERTON • JOSEPH J CHIZMARIK • KYUNG-JIN CHOI • JEFF CHRISTENSON • H CHUANG • DONALD L CHUBB • WENDELL CHUN • DAVID A CINTRON • ANTHONY CIOFFE • LOUIS J CIRCEO • BENTON C CLARK • ALDEN MICHAEL CLAUSEN • ROBERT R CLEAVE • ROBERT H CLEGG • JAMES EDWARD DAVID CLINE • SIDNEY N CLOUSTON • GORDON CLOW • RON COBB • EMMETT J COIN • CRAIG COLE • JOHN COLLINS • ANTHONY COLOZZA • JAMES D COLTON JR. • MICHAEL A COMBERIATE • STEVEN L COMEE • HAROLD COMPTON • BERNIE CONNEELY • D COOLEY • KERRI ANN COPAS • BRIAN LEE CORBER • DOROTHY L CORDAY • PAUL CORDER • PATRICK CORNELIUS • SUSAN COROMINAS • RICHARD D CORSON • JOSEPH J COSTELLO • ROBERT C COSTEN • CLARK E COTTRELL • MAYNARD COWAN • TODD PAUL COY • ROGER A CRANE • LUANN CRESS • DAVID R CRISWELL • BOB CROMWELL • THOMAS W CROWE • HATICE S CULLINGFORD • THOMAS CONWAY CUMMINGS • GLENN E CUNNINGHAM • BRUCE V J CURLEY • PETER A CURRERI • TODD M CURRY • JOHN R CURTIS • ROSSI D'PROVIDENCE • RICHARD C DAHLBERG • SHIRWYN DALGLIESH • FRANK THOMAS DAMBRO • WALTER DANIEL • TIM DASCHBACH • LEONARD W DAVID • PRINCE DAVID • BILLY K DAVIS • DANNIE EARL DAVIS • HUBERT P DAVIS • I LEE DAVIS • KEITH H DAVIS • RUSSELL W DAVIS • STEVEN J DAVIS • DAVID DAVISON • SIDNEY S DAVISSON • ESMOND GARY DEAN • D. DEAN • ALVA W DEATON • DEL DECKER • EDGAR JOHN DECKER • PAUL A DEPONZO • JAMES DEGNAN • CHANDRA S DESAI • MARC DEVENY • HARI P DHAR • PHILIP DICKERSON • DAVID W DICKINSON • EDWARD DIEZ • THOMAS A DIGGS • DENNIS DILLMAN • GEORGE DINGLER • VINCENT DIPIETRO • ALEXANDER F DOMAL • WARREN L DOWLER • DOUGLAS EVAN DRENKOW • G DRESCHHOFF • W B DRIVER • ROBERT DRWL • LARRY L DUIS • HARVEY L DUNCAN • BRUCE P DUNN • F E DUNNAM • LAURENT • JIM DURDEN • GARY DYE • JAKE EASTIN • SUSAN EBERLEIN • B ECKLAND • SULEIMAN C EDMONDSON • HAROLD NATHANIEL EDWARDS • JOHN C EDWARDS • DAVID EISENBERG • FRANCISCO ELIAS-REYES • THOMAS LEE ELIFRITE • WILLARD ELMORE • GARVIN R EMANUEL • JAMES K ERICKSON • WILLIAM J D ESCHER • WILLIAM J D ESCHER • DAVID WILLIAM EVANOFF • RICHARD C EWELL • JOHN FABIAN • RAYMOND FABIAN • JOHN FADULL • ARTHUR W FAGAN • M FAIR • ANDREW FALCONER • HOWARD E FALLS • P H FANG • ALFRED E FANT • ALEX FARKAS • ROBERT W FARQUHAR • EMIL P FAUCHER • MALCOLM H FAUST • OTTO H FEJTOR • HEATH BRYANT FEHRSON • CALVIN FELDMAN • JAMES E FERGUSON • WILLIAM W FEW • PAUL FEZIORCZAK III • JUDITH FIELDER • LYNN L FIELDING • CHARLES C FILLIE • DAVID G FINDLEY • DALE FINK • ZELDA MARY FISCHLER • JERRY D FITZ • GARY O FITZPATRICK • MICHAEL FLAHERTY • DON FLETCHER • ROBERT F FLETCHER • RICARDO A FLORES • PAUL FLUMM • M FOALE • MICHAEL K FOGLEY • LYNDIA A K FOLEY • DAVID V FORREST • EDWARD B FORT • RICHARD W FOSTER • THOMAS FRANKIE • NICCOLAS L FRANZ • ROBERT LEE FRAZIER • IAN FRENCH • URSULA G FRETZ • JAMES C FRIEDLE • BRUCE FRIEDMAN • SUE FRIEDMAN • THOMAS J FRIELING • LARRY J FRIESEN • WARREN FRISINA • ROGER D FRITZ • JANICE D FROGEL • TIMOTHY P GABB • BRUCE GAGNON • MICHAEL J GALLAGHER • PATRICK M GALLETTA • MARIA LUISA GARCIA-LEDO • O GARRIOTT • RICHARD GARWIN • EDWARD R GENERAZIO • STEPHEN R GERIG • GLORIA GIARDINA • R DAVID GIBBY • TOM GIRALICO • HENRY DEL GIUDICE • CHRISTOPHER G VON GLAHN • PETER E GLASER • BENNY CARL GLASGOW JR. • DANIEL GLOVER • DANIEL R GLOVER • GEORGE GODLIN • JENNIFER GODWIN • BERNHARD GOETZ • LEONARD GOLD • MARK GOLDES • GILBERT R GONZALES JR. • TERRY LEE GOODNO • ALAN C GORE • F G GORMAN • P GOULD • DAVID D GRAHAM • JOHN GRAHAM • RALPH R GRAMS • BOB GRANT • GARY E GRAVES • JAMES TONY GRAY • ZACHARY GRAY • BYRON DAVID GREEN • GARY A GREENBAUM • BOB GREENBERG • DAN GREENWOOD • JUSTIN ERIC GRIFFIN • ANTHONY D GRIFFITH • BILL GRISOLIA • PETER VON GRONEFELD • ANN E GROW • GENE GUERNY • DAVID GUMP • HAROLD J GUTLIAN SR • WARD J HAAS • ROGER W HACKET • MICHAEL A HAGEN • DANA M HAGUE • YACOV Y HAIMES • J HAILSLIP • GERALD B HALLAHAN • PATRICK E HAMEL • THOMAS W HAMILTON • DAVID M HAMMOCK • WALTER E HAMMOND • TOM HANNA • ORVILLE W HANNEMAN • HANS F HANSON • JAMES G HANSON • JOHN M HANSON • CHARLES O HARMIA SR • W HARPER • KIT HARRIS • WILLIAM HARVEY • OLIVER P HARWOOD • THEODORE H HAUTA • DREW A HAWKINS • DAVID HEEGER • THOMAS F HEINSHEIMER • E M HELICH • THOMAS R HENCKE • DANIEL W HENDERSON • LEONARD WARREN HENNESSY • ORJAN HENNINGSON • HERBERT HENSEL • H KEITH HENSON • CHARLES DARWIN HEPBURN • FRED HERMAN • ISMAEL R HERNANDEZ • CAL C HERRMANN • JEFFREY W HERRMANN • GREGORY A HERUTH • BRIAN VON HERZEN • ROBERT HILDEBRAND • ERNEST HILDNER • GERALD J HILL • MINOT D HILL • W J HINES • JOHN L HINRICHS • GERARD JOSEPH HINZMAN • STEVEN HIRSHORN • JIM HIX • MARTIN A HJORTSO • TRENT A HOBBS JR. • LAWRENCE G HOECKER • MURRAY HOFFMAN • ROBERT F HOGGE • STAN T HOLBROOK • DENNIS HOLLENBERG • ALAN C HOLT • CLYDE N HOLTZAPPLE • RENE A DE HON • JACK B HOOD • JAMES M HOOP • HAL HORNE • ROBERT W HORST JR. • FRIEDRICH HORZ • DAVID HOSKINS JR. • DEBBIE HOUDEK • SAM HOUSTON • BRUCE A HOUTCHENS • L E HOVLAND • VERN HOWARD • ALICE HOWELL • JOE HUGHES • JOHN H HUGHES • EDWARD J HUJSAK • INGEMAR HULTHAGE • JOHN HUNTER • RONALD L HUSTON • CALVIN S IDE • CRAIG I IMANSE • JOSEPH C IOZIA • GREGORY IRWIN • LON B ISAACSON • CHRISTOPHER MARTIN ISGVIG • BRUCE IVERSEN • GLEN IWASAKI • CHRIS JACKSON • RORY D JACKSON • NATHAN JACOBI • JAMES ROBERT JACOBS • LARRY B JACOBS • JAMES R JACOBSON • CHRIS C JAMERSON • JOHN E JAMES • RECKIE ANERCLY JAMES • STEPHEN JAMES • JAMES R ARNOLD AND ASSOCIATES • EVANDER JAMISON • BRUNO M JAU • LYLE M JENKINS • TOMMY LEE JENKINS • LYLE JENKINS • KARL JENSEN • CLIFFORD JOHNSON • DOUG JOHNSON • KENDALL L JOHNSON • STEVEN R JOHNSON • THOMAS F JOLLY • BILL JONES • MARC JONES • RICK JONES • RONALD M JONES • M JORDAN • MICHAEL A JORDAN • PETER JORDAN • A T JOYCE • EDWARD GEORGE JUDSON • C G JUSTUS • RICK KADUNC • JOSEPH KAHR • JOHN DEMETRIOS KALAMAS • KARL CASH KALBAUGH • MEGUER V KALFAIAN • JOHN J KALVINSKAS • TERRY KAMMASH • WILLIAM KANJORSKI • S K KATTI • JAMES MICHAEL KELLER • RUDOLF KELLER • DEAN KELLER • DONALD A KELLY • THOMAS WALTER KELLY • JEFF KELSEY • WINSTON EDWARD KENDRICK JR. • JAMES JOHN KENDZIERSKI • NEIL KENNEY • SHEA F KENNY • KEITH KENT • EARL KEPNER • WILLIAM KERNEY • SHIRLEY ANN KIMMEL • VINCENT S KINACK • CHRISTOPHER KINANE • NELSON E KING • J E KINGSBURY • NATHAN KIRK • S W KIRKPATRICK • HENRY L KIRSCH • RONALD KLASKEY • JOHANNES KLAUS • LAURENCE D KLEIN • LINDA S KLEIN • HOWARD KLEINBERG • CHARLES M KNOP • CHRISTIAN W KNUDSEN • AREND JAN KNUTTTEL • N KOBYRN • DAVID KOCH • VICTOR R KOCH • DONALD KOLESON • ROBERT P KOONTZ • DALE M KORNFELD • JOSEPH J KOSMO • GEORGE M KOVAC • MICHAEL G KRAMER JR. • KELLY A KRATOCHVIL • R JEFFREY KRAUSE • STANLEY KRAUTHAMER • TIM J KRETTNER JR. • ZELIMIR KROKAR • BEN W KRONE

ERIC KROTKOV • HOWARD A KUHNLE • LAWRENCE H KUZNETZ • LAWRENCE KUZNETZ • JOHN ROBERT LA COMBE • MATHIAS ROBERT LABBE • C M LAIRD • FRANCIS J LAMAY • WINGATE A LAMBERTSON • GEOFFREY A LANDIS • KENNETH R LANG • KEVIN LANGDON • PETER LANGE • RICKY LANGLEY • EDWARD LANTZ • DAVID B LAPADULA • DAVID LAPADULA • RICHARD W LAPPLE • KEN M LAU • HOWARD LAUCK • PAUL A LAVIOLETTE • W F LAWLESS • KING H LEE • PASCAL LEE • NICKOLAUS E LEGGETT • PHILIP LeGOY • JAMES H JIM LEHMAN • GERALD G LEIGH • RAYMOND S LEONARD • STEPHEN LEPP • DANIEL J H LEVACK • GILBERT V LEVIN • L J LEVINE • SIDNEY LEVY • C LEWIS • CARL F LEYSE • JONATHAN A LIEGNER • CANDICE LILLIE • T D LIN • BRADFORD S LINSOTT • R J LIPINSKI • JOSH RANDALL LIVINGSTON • RUPERT L LONA • JAMES LONG • ART LOPEZ • STANLEY G LOVE • JAMES D LOWE • CHARLES ALLEN LOWRY • MARY LOZANO • KURT LUND • KORAC MACARTHUR • JAMES A MACHIAS • MARK H MACHINA • DANIEL B MACIEJ • BRUCE A MACKENZIE • STEPHEN W MALONEY • MICHAEL J MANFREDI • JOSEPH J MANGAN • BALDEV S MANGAT • W M MOSES • ALBERT MANIAN III • RUTH MARGALIT • JEFFREY S MARGOLIS • WILLIAM J MARINELLI • BRIAN MARKUSAN • MICHAEL JAMES MARRON • BILLY D MARSHALL • DAVID LANCASHIRE MARSTON • JOHN MARZOCCHI • THOMAS MASON • MICHAEL ANGELO MASSA • FRANCESCA MASTRO JR. • PHILIP A MATCOVICH • DAVID MATUSOW • MICHAEL JOSEPH MAY • OWEN MAYNARD • ORLANDO A McALLISTER • KATHERINE MCCALL • DEAN McCLOD • ROGER McCORMICK • EDWARD D McCULLOUGH • JAMES P McDANELL • JAMES McENALLY • JAMES E McGEE • RICHARD R McIVER • THERESA MCKAY • DAVID S MCKAY • RORY McLEAN • MALCOLM McMULLEN • VERA MEADER-PERNA • JOHN MECCA • WILL C MECHLING • WALTER V MEDENICA • R MEESTER • MASTERER MEHDEN • HERSCHEL R MELTON • CARL MENTELE • L H MEREDITH • MICHAEL R MERINO • MARSHALL L MERRIAM • DAVID MERRIMAN • ELEANOR MERRIMAN • SUSAN M MERRITT • MICHAEL WILLIAM MESSER • MICHAEL L MEYER • RUDOLF X MEYER • K MEYER • DANNY MICHALOWICZ • STEVEN A MICKLER • DARIUS J MIKULSKIS • GEORGE H MILEY • RICHARD K MILLER • RONALD A MILLER • BARRY D MILLS • CARL S MILSTED • PAUL VON MINDEN • LYNN E MINER • MARVIN MINSKY • PAUL MIRANDA • GLENN R MITCHELL • PAUL MITCHELL • TERRY R MITCHELL • SHAWN MOCKUS • ALEX MONCHAK • CHARLES A MONROE • GARY T MOORE • GARY T MOORE • R MOORE • WAYNE MOORE • PHIL MORALES • MARK K MORAN • DOUGLAS MORROW • RICHARD MORSE MORSE • THOMAS M MORSE • W M MOSES • MIKE MOSS • MICHAEL D MOWERY • HOWARD L MOXHAM • H WALTER MROCH • JOSEPH MUELLNER • SANDRA MUELLNER • DANIEL H MUES • M L MUGA • GERALD M MULENBURG • CHARLES F MULLEN • CHARLES R MUNDELL • MARC MURBACH • THOMAS M MURRAY • RALPH MUSCATELL • DOUGLAS E MUSIC • TAKASHI NAKAMURA SR. • MARK E NALL • MATTHEW M NARDELLA • ANTHONY P NARDI • JOEL NATHANSON • THEODORE H NATHANSON • JOHN A NAULIN • PEDRO J NAVARRO • BRYAD NEELY • TIMOTHY NEEENO • FREDERICK R NEHEN • MARK NELSON • RICHARD O NELSON • GREGORY W NEMITZ • ARNE NEREM • MELVIN K NEVILLE • MARJORIE S NEWELL • MICHAEL J NEWHALL • GEORG M NEWMAN • RICHARD A NEWTON • ORAN W NICKS • C NIEMCZUK • LLOYD NISSLEY • JASON TODD NOBLE • VALENTIN X NORIEGA • MARTIN R NORTHROP • PETER NORTON • EDWIN I NUSINOW • MARK O'CONNOR • GERARD K O'NEILL • FAIRBORN OBSERVATORY • RONALD A OLANSEN • DENNIS OLIVARES • KIRK OLSSON • WILLIAM A ORAN • UGUR ORTABASI • RICHARD S OUSLSKY • ROBERT B OWEN • GERALD PAGE • BRYAN PALASZEWski • TOM G I PALERO • CARL B PALLAVER • CHARLES W PALMER • MILES R PALMER • MILES R PALMER • JERRY L PALUMBO • E L PAQUETTE • B PARK • ROBERT E PARKIN • STEVE PARKS • DAVID PARRIS • JAMES C PASSMORE • SALVATORE VINCENT PASTINO • MATTHEW PATTERSON • KEITH A PAULEY • VALENTIN PECHORIN • K L PEDDICORD • PETER J PEIRANO • PAUL A PENZO • JERRY A PEOPLES • ALVIN C PEPPIATT • REINALDO PEREZ • MARLA E PEREZ-DAVIS • MIGUEL MUNOZ PEROU • ARTHUR T PERRY • XENPHONE PETEBURRIS • ROBERT D PETERMAN • JEROMY G PETERSON • DAVIS DEAN PETIT • MIKE PETITT • BILL L PIERCE • CARL M PIETERS • DEAN PILATO • ELLIOTT T PILCHARD • PHILIP JOSEPH PAUL PINTA • DOMINICK PINTERPE • JESSE R PIRTLE • DONNA SHIRLEY PIVIROTTA • MICHAEL A PLESKOVICH • BRUCE PLETKA • FRED A PLOFCHAN • ALEX POGOSTIN • JAMES A PORI • JOHN R PORTER JR. • V R PORTER • JONATHAN V POST • WILLIAM T POTTER • MARY POULTON • JAMES POWELL • R POWERS • GEORGE L VON PRAGENAU • DARRELL PREBLE • DAVE PRESSLER • HUMPHREY PRICE • GERARD PUCCI • NANCY J PUCKETT • ANTONIO M PUERTA • FRED PUHN • R RADHAKRISHNAN • DAS RAMNATH • B P C SEKHARA RAO • JOHN D G RATHER • SHERMAN RATTNER • CLINT ALAN RAY • LAURENCE DAVID REBHUN • EBERHARDT RECHTIN • K L REIFSNIDER • ARNOLD G REINHOLD • CHARLES F REINHOLTZ • RALPH RENE • JOSEPH A RESNICK • ANDREW REYNOLDS • MICHAEL RHEE • GERALD RICHLING • JASON RICO • TODD H RIDER • JOSEPH A RIED • ROBERT RILEY • REED D RINER • MARC RINGUETTE • ERIC ROBBINS • WINSTON F ROBBINS • LEONARD ROBERTS • EUGENE G ROBINSON • UWE ROCKENFELLER • WILLARD F ROCKWELL • KENNETH A RODDY • CHARLES E ROGERS • JAMES L ROGERS • DONALD J ROMANZO • CHARLES A ROND • RAJENDRA RONVELWALA • CLIFFORD ROSE • LOWELL ROSEN • JOHN M ROSEVEAR • MICHAEL ROSS • BRUCE ROTH • CASEY ROWLAND • ALLAN W RUPPAR • BRADLEY CRAIG RUSH • MONICA RUSSO • DAVID A RUTTER • ELRIC W SAASKI • MARY ELIZABETH SABOL • MICHAEL D SALATHE • JOHN SAMPSON • BRENDA SANDERS • GEORGE F SANGER • LISA A SANTORA • MIKE SATCHER • R SCOTT SATTERWHITE • JEREMIAH M SAUNDERS • DONALD R SAUVAGEAU • SAM A SCHILLACI • RALPH SCHOMBURG • E J SCHONEBERGER • JAMES SCHULZ • ARTHUR E SCHULZE • NORMAN R SCHULZE • HENRY J SCHUREN • DAVID SCOTT • JAMES J SECOSKY • KENNETH N SEGAL • JUSTIN SENESE • CONSTANCE L SENIOR • DAVID J SENOR • LEON SHAMESON • RANDEL OSCAR SHAPIRO • ROBERT J SHARP • BURTON L SHARPE • MARYLIN K SHEDDAN • MART SHEFFIELD • D SHEPARD • P DEAN SHERIDAN • JAMES C M SHERRY • RICHARD SHIMANSKY • LEWIS ANTHONY SHIPMAN • ROBERT SHISHKO • JAMES L SHORDEN • LEROY F SILVA • MELODY A SILVER • JOHN F SILVIS • MARVIN SIMKIN • WILLIAM E SIMON • WARREN K SINCLAIR • MICHAEL JAY SINGER • DMYTRO SKYBYK • JAMES H SLOAN • BOYD E SMITH • EVAN A SMITH • GARY C SMITH • JOSEPH RODGER SMITH • MARK ETHAN SMITH • O G SMITH • THOMAS SMITH • JAMES M SNEAD • W VAN SNYDER • MICHAEL J SOHNL.Y • JOHNDALE C SOLEM • BERTRAM D SOLOMON • PHILIP SOLOMON • LEROY M SPARR • DONALD S SPENCER • NAPHTALI SPIEGEL • PAUL D SPIEWAK • DONAT L ST. • ROBERT L STAEHLE • JOHN C STAFFORD • PETER STARK • DAVID S STAUFFER • JESSICA STEADMAN • JAMES K STEDMAN • ROCHELLE K STEELE • BRETT VAN STEENWYK • ALEXANDER STEFAN • WILLIAM STEIGERWALD JR. • MARVIN STEIN • ALLAN STEINBOCK • TERRENCE STENDER • ROBERT F STENGEL • SEAN STEPHENS • RICK L STERLING • MARTIN O STERN • MICHAEL STEVENS • ROBERT STEWART • PATRICK STINSON • CAROL STOKER • JAMES STOOBS • L R O STOREY • JAY LEROY STOWELL • STEPHEN D STRATOTI • THOMAS CHRISTOPHER STREET • JOHN K STRICKLAND • J STRICKLAND • LAMONT STRINGFIELD • W C STROBL • W E STROTE • W G STROUD • BRUCE E STUCKMAN • E STUHLINGER • JOHN R STULCE • MARK STURGIS • CHARLES J SULLIVAN • THOMAS A SULLIVAN • THOMAS F SULLIVAN • JOHN F SUTTON • PETER A SWAN • ROLAND SWANK • THOMAS SZIRTES • BRUCE DAVID TABOR • JOSEPH L TAFFE • RAYMOND M TAMURA • RUSIN TAN • E RAY TANNER • LINDA J TANNER • R TANNER • MICHAEL E TAUBER • E JENNINGS TAYLOR • WILLIAM D TAYLOR • WILLIAM J TERRY • MADHU THANGAVELU • FRANK P THOMAS • CHARLES O THOMPSON JR. • WILLIAM B THOMPSON • WORTHINGTON J THOMPSON • EARL A THORNTON • WILBUR L TILLSON • MICHAEL TINNIRELLO • ALAN J TOEPFER • OSVALDO LUIS TONON • PAUL TORRANCE • OSVALDO A TORRES • STEPHEN MICHAEL. TOTH III • C BRIAN TOWEY • BRUCE ARTHUR TROTT • P TURECK • PHILIP A TUREK • RANDOLPH L TURNER • CHESTER TUSZYNSKI • DAVID J ULMER • RESIT UNAL • JAVIER A VALENZUELA • THOMAS H VAN HAGEN • LANCE VAN LEWEN • RICHARD GERARD VAN TREUREN • SCOTT ALAN VANDAM • W VANING • R VANN • JIMMY VARNAVAS • KOSTA VARNAVAS • GIULIO VARSİ • JAMES VAUGHAN • RAY VAUGHN • ZORAN VELISAVLJEVIC • RICHARD E VINCEK III • TYLER VOLK • MANFRED H VON EHRENFRIED • HAYDN WADLEY • EDUARDO M WAISMAN • ALLEN R WALKER • JAN WALLACE • THOMAS M WALSH • GERVINO A WALTER • TAYLOR G WANG • RANDOLPH WARE • CLINT WARMATH • ROXANNE R WARNIERS • MARK S WASESCHA • ALAN WASSER • R W WATERHOUSE • ANDREW B WATSON • MATTHEW WATSON • ANDREW R WAYMAN • LYNN EDWARD WEAVER • WILLIE RAY WEAVER • BRENT J WEBB • BILL WEDEL • RICHARD WEIDNER • JOHN F WELZ • RICHARD M WESTFALL • JOHN B WETSCH • JOHN R WETSCH • JOHN WETSCH • GUY WEYL • WILLIAM BRYANT WHEAT • MORENO WHITE • FRANK WHITLATCH • LAURA A WHITLOCK • STEWART B WHITNEY • BERNHARD L WIESENMAIER • ROBERT WIGAND • BRIAN WILCOX • P WILEY • DOUGLAS L WILLIAMS • ELDEN WILLIAMS • JOHN BRYANT WILLIAMS III • KATHERINE ANN WILLIAMS • CHAS WILLITS • GERALD WILSON • THOMAS L WILSON • JEANNE WINTER • SAMUEL G WOINSKY • LARRY WOLFF • DONALD A WOLOCHOW • MOSES WONG • CLIFFORD WONG • JOHN J WORDIN • E WORLE • HOWARD T WRIGHT • ISAIAH Y YAGIL • D H YOST • JOHN TRAVIS YOUNG • ED ZADOROZNY • STAN W ZASKE II • PAUL ZEFF • E J ZELLER • HENRY W ZENOCK • ALISON ZIEGLER JR. • JIM ZOOK JR. • ROBERT ZUBRIN JR. • K ZURECK • CHARLES ZWEIBACH •

American Institute of Aeronautics and Astronautics Participants

A Dwight Abbott, The Aerospace Corp • Edwin E “Buzz” Aldrin, Starcraft Enterprises • H D Armstrong, Applied Technology Associates • Randal A Atkeisson • David Baker, Sigma Projects, Ltd • Walter L Baldwin, Jr • Allan P Bangs • Enrique Barbieri, Tulane University • John Bares, Ford Aerospace • Henry J Barten • Stephen H Bartnelson • Eric Basques, The Mitre Corp • Perkins Bass • Fred Becker • Raymond H Bolduc II, Tronco • Stan Boraas, Thiokol Corporation • Roger O Bourke, Jet Propulsion Laboratory • Robert G Boyd, Martin Marietta • J Kurt Brock, Ford Aerospace • William C Brown, Microwave Power Transmission Systems • Michael A Brown, Space Telescope Science Institute • Corinne Buoni, SAIC • Jeff B Burl, Naval Postgraduate School • Daniel J Burns, Lockheed Missiles & Space Company • John Bush • Jon A Buttram, Vitro Corporation • David P Cadogan, Dover Inc • John E Canady • D R Cargille, Hughes Aircraft Company • Steven R Carolus, Carleton Technologies Inc • Joseph A Carroll, Tether Applications • Alfred G Cattaneo • Benton Clark, Martin Marietta • Bud Clevert, Cleveland • Ethan Wilson Clifton • Starr J Colby • Michael Cooper • Michael J Coppi • Bruce M Cordell, General Dynamics • Charles L Cowan, GE Aerospace • David R Criswell • D C Crockett • Andrew Cutler, University of Arizona • Andrew Daga, Integrated Space Systems Corp • Richard Dahlberg, General Atomics • Keith A Davis, Allied Signal • Darrick Dean • E E Decker • Martin Dowd • Bruce P Dunn • V N Dvornychenko, Northrop • Steve Dwornik, Ball Aerospace • Manfred von Ehrenfried, TADCORPS • Joel L Ekstrom, Motorola Inc • Colin J Etheridge • Melody Fair • G H Farbman, Westinghouse Electric Corp • Alex Farkas • Robert Farquhar, NASA • Frederick D Ferguson, Northern Aerospace Industries • Robert L Forward, Forward Unlimited • Colin M Francis • Jerry Friefeld, Rockwell International • Patrick M Galletta, Ford Aerospace • John M Garvey • Martin Gerloff • John A Gilbert, University of Alabama, Huntsville • Matthew Golombek, Jet Propulsion Laboratory • David Goracke, Rockwell International • Stephen Gorevan, Honeybee Robotics • Francis Graham, Kent State University • David D Graham, SLUGS • Jerry Grey, AIAA • Brand N Griffin, Griffin/Hudson • Leslie De Groff, Intelli Corp • Jeff Hagen • James N Haislip Jr • John M Hanson • P R Harris, NETROLOGIC • Philip R Harris, Harris International • O P Harwood • Daniel E Hastings, Massachusetts Institute of Technology • Scott Havener • William H Heidbreder • Thomas F Heinsheimer, Titan Systems Inc • Mark Hempself, British Aerospace • Mark Henley, General Dynamics • J Stephan Herring, Idaho National Engineering Laboratory • Henry A Hoff • Michael J Hoke, Abaris Training Ltd • Jeff Hollowell • Alan Holt • W C Home • Ken Huber • Lawrence M Hughes, Hughes Aircraft Corporation • Edward J Hujzak • Ronald L Huston, University of Cincinnati • Bonnie James, Georgia Institute of Technology • Carlos Moreno, Jet Propulsion Laboratory • Richard Johnson, Rockwell International • Daniel P Johnson, Honeywell • Reese Johnson • Michael A Jordan, The Mitre Corporation • M E Jordon • Michael Vincent Jupo • C G Justus, Georgia Institute of Technology • Ali E Kahlil, GE Aerospace • Jordin Kare, Lawrence Livermore National Laboratory • J S Kargel, University of Arizona • John G Kasalo • Bill Kelly, The Marquardt Company • Hugh Kelso, SLUGS • Rodney Kendrick, SLUGS • Michael Kerpchar, The Kerpchar Company • James N Kile, Applied Research & Engineering Inc • Charles B King, The Bionetics Corp • Brian P Kosinski • Clifford R Kurtzman, Space Industries International Inc • Geoffrey Landis • Vern R Larson, Rockwell International • James L Latimer, Hughes Aircraft Co • Robert F Latter • Jeffrey L Lee, Hughes Aircraft Co • Michael F Lembeck • Joseph Levine • Carl F Leye, Idaho National Engineering Laboratory • J Kirby Lidman • Ronald J Lipinski, Sandia National Laboratory • William Lipinski • Chang P Liu, Hughes Aircraft Co • Walter Lockhart, Southwest Research Institute • S M Lord, NASA • Stan Love, SLUGS • Charles C Lozar, Architects Equities • Javier de Luis, Massachusetts Institute of Technology • Jan Stephan Lundquist, USAF • James E Maher • Richard Malecki • James D Maloy • Donna Marts, Idaho National Engineering Laboratory • Jim Matzenauer • O E Maynard • John P McDonnell • Richard McFadden, SAIC • David McKay, NASA • W McKee, McDonnell Douglas • Angus McRonald, Jet Propulsion Laboratory • Thomas A Meier • Andrew Meisel, Hughes Aircraft Co • Rudolf X Meyer, University of California at Los Angeles • Michael A Minovitch, Phaser Telepropulsion Inc • Gary T Moore • Mark K Moran, Teledyne Brown Engineering • Daniel J Moser • Richard L Mullikin, Hughes Aircraft Co • Makoto Nagatomo, Institute of Space & Astronautical Science • Michael Neely, CTA Inc • M J Neufeld, Hughes Aircraft Co • JoEllen Neumann, Idaho National Engineering Laboratory • George Nossaman, IBM • Wilfred Nugent • Robert L O’Brien, United Technologies • Scott Ogilvie • Bryan Palaszewski, NASA • Miles R Palmer, SAIC • F Palmer, Hughes Aircraft Co • Link A Parikh, CTA Inc • Robert L Percy, Rockwell International • John C Peterson, Jet Propulsion Laboratory • Richard Craig Peterson • Vincent L Pisacane, Johns Hopkins University • Donna Shirley Pivrotto, Jet Propulsion Laboratory • Frank Pometto • Paul Porreca • Joseph Poynton • W A Ragsdale • Mark D Ralston • Stephen H Rapp, University of Colorado • Donald Rea, Jet Propulsion Laboratory • Carol Luckhardt Redfield, Southwest Research Institute • Al Reisz, Reisz Engineering • Ed Repic, Rockwell International • Richard Reul • Aamer Rizvi • R R Robbins, Idaho National Engineering Laboratory • Auro Roselli • Prodyot Roy, GE Aerospace • William K Rule, University of Alabama • B J Rumery, Hughes Aircraft Co • Robin R Ruscak • S Salgaller, Hughes Aircraft Co • Michael F Sarabia • Eagle Sarmont, Lockheed • Arthur Schnitt • Norman R Schulze, NASA • Gerald R Seeman, Developmental Sciences Corp • L Sharp, The Aerospace Corporation • E Shavartz, Rockwell International • Eric J Sheppard • Brent Sherwood, Boeing • Eric J Shinaver, Hughes Aircraft Co • Michael Sims, NASA • James H Sloan • Robert K Smith, Sverdrup Corp • John V Smolik, Hughes Aircraft Co • James M Snead • Michael Stanford, McDonnell Douglas • Edward A Stark • Henry R Sterner, General Dynamics • D Strenski, Michigan Technological University • John K Strickland Jr, Austin Space Frontier Society • Thomas A Sullivan, NASA • Ken Smith, Sverdrup Corp • Peter Swan, Motorola Inc • V Thiagarajan • Frank Thomas • A J Toepfer, SAIC • Michael W Traffenstedt • Philip A Trunek • Vernal M Tyler • James R Underwood, Kansas State University • University of Wisconsin • Randy Ushiyama, Allied Signal • George L Von Pragenau • Marvin Wachs, Hughes Aircraft Co • Eduardo Waisman, S-Cubed • Jerry Wald, Honeywell • William Weitzen, General Technology Applications Inc • Richard Westfall, Galactic Mining Industries Inc • Walt Williams • Alan J Willoughby, Analex Corporation • Dale Wolfe • Moses Wong, Spar Aerospace Ltd • Samuel W Ximenes Grumman • Niels Young • John Zabriskie, Idaho National Engineering Laboratory • Robert Zubrin, Martin Marietta

ABORT CRITERIA

Edgar C. Lineberry, NASA,
Johnson Space Center

ACQUISITION

Glynn Lunney, Rockwell International

ACQUISITION PRACTICES

RADM Stewart Evans, USN (Ret.),
NASA Headquarters

ACQUISITION STRATEGIES

George Jeffs, Rockwell International

ACQUISITION STRATEGY

James R. Thompson, Jr.,
NASA Headquarters

**ACQUISITION STREAMLINING
FOR THE SPACE EXPLORATION
INITIATIVE-WHITE PAPER**

Lt. Gen. Donald L. Cromer, USAF,
Space Systems Division

ADVANCED LIFE SUPPORT

Bruce W. Webbon, Ph.D., NASA,
Ames Research Center
Robert D. MacElroy, NASA,
Ames Research Center
William Berry, NASA,
Ames Research Center

ADVANCED PROPULSION

John Brandenburg, Ph.D.

ADVANCED PROPULSION

Stan V. Gunn, Rockwell International,
Rocketdyne Division

ADVANCED PROPULSION

Franklin R. Chang Diaz, NASA,
Johnson Space Center

ADVANCED PROPULSION

Mitat A. Birkan, Air Force Office of
Scientific Research
Robert W. Bussard, Ph.D.,
Energy / Matter Conservation
Corporation
David Krusch, NASA,
Ames Research Center
Woodward Waesche, NASA,
Ames Research Center

**ADVISORY COMMITTEE
ON THE FUTURE OF THE
U.S. SPACE PROGRAM**

Norman Augustine,
Martin Marietta Corporation

AEROBRAKE

Alan Adams, NASA,
Marshall Space Flight Center
Tom Dickerson, NASA,
Marshall Space Flight Center
Charles Eldred, NASA,
Langley Research Center
Ron Harris, NASA Headquarters
Bill Huber, NASA,
Marshall Space Flight Center
Kent Joosten, NASA,
Johnson Space Center
Jim Raper, NASA,
Langley Research Center
Steve Wander, NASA Headquarters
Gordon Woodcock, The Boeing
Company, Boeing Aerospace and
Electronics Division

**AN ALTERNATIVE ADVANCED
LAUNCH SYSTEM PROGRAM**

Michael Griffin, Ph.D., Department of
Defense, Strategic Defense Initiative
Organization

**ANTARCTIC ANALOG PROJECT
PLAN FOR PLANET SURFACE
SYSTEMS (PRELIMINARY)
INTERIM REVIEW**

Corinne Buoni, Science Applications
International Corporation

**ANTARCTICA AS MOON / MARS
PRECURSOR**

Carol A. Roberts, Ph.D.,
National Science Foundation
John T. Lynch, Ph.D.,
National Science Foundation

APOLLO PROGRAM MANAGEMENT

Brigadier General James A. McDivitt,
USAF, (Ret.), Gemini IV, Apollo IX,
Rockwell International

APPLICATIONS OF TELEROBOTICS

Joe N. Herndon,
Oak Ridge National Laboratory

**ARCHITECTURES / SPACE
EXPLORATION INITIATIVE/
STRATEGIC DEFENSE INITIATIVE
ORGANIZATION**

Lt. Gen. Jim Abrahamson, USAF (Ret.),
Hughes Aircraft

ASSURED CREW RETURN VEHICLE

Barbara S. Askins, NASA Headquarters

**ASTEROIDS SCIENCE AND
MISSIONS POTENTIAL**

Clark R. Chapman,
Planetary Science Institute
Don Davis, Planetary Science Institute

ASTROCYCLER SYSTEM

Col. Edwin E. Aldrin, USAF (Ret.)

**BOEING AND ROCKWELL / SINGLE
STAGE-TO-ORBIT**

Gary L. Briley, Rockwell International,
Rocketdyne Division
Peter K. Cocolis, Rockwell International
Elden Davis, The Boeing Company,
Defense and Space Group
Mike Hampson, Rockwell International,
Rocketdyne Division
Denton Hanford, The Boeing Company,
Defense and Space Group
John P. Lowden, Rockwell International,
Rocketdyne Division

**BOEING / INDUSTRY
PRESENTATION**

Gil Keyes, The Boeing Company,
Defense and Space Group
Jim Kingsbury, The Boeing Company,
Defense and Space Group
Gordon Woodcock, The Boeing
Company, Boeing Aerospace and
Electronics Division
Carl Case, The Boeing Company,
Defense and Space Group
Brent Sherwood, The Boeing Company,
Defense and Space Group

CASE FOR MARS

Barbara Sprungman,
Space Data Resources, Inc.

CENTRAL COMMUNICATIONS SYSTEM

A. A. Adkins, NASA,
Lewis Research Center

COMMAND, CONTROL, COMMUNICATIONS—MISSION OPERATIONS OVERVIEW

John O'Neill, NASA,
Johnson Space Center

COMMERCIAL LUNAR PROGRAM

Mike Lawson,
Space Marketing Concepts
Alan Binder,
Lunar Exploration Incorporated
Preston Carter,
Lunar Exploration Incorporated

CONGRESS AND THE SPACE EXPLORATION INITIATIVE

Senator Edward Jacob Garn

CRYOGENIC FLUID MANAGEMENT/ SPACE AND SURFACE POWER

Irv Sumner, NASA,
Lewis Research Center
John Smith, NASA,
Lewis Research Center

DEFENSE MANAGEMENT REVIEW IMPLEMENTATION STATUS REPORT

Ann Reese,
Office of the Secretary of Defense

DEPARTMENT OF DEFENSE BRIEFING ON SPACE EXPLORATION INITIATIVE TECHNOLOGY

Lt. Gen. Donald L. Cromer, USAF,
Space Systems Division
Col. Brent Collins, USAF,
Space Systems Division
Col. Roger T. Colgrove, USAF,
Space Systems Division
Col. James M. McCormack, USAF,
Air Force Systems Command
Col. Lee Norton,
Army Corps of Engineers

DEPARTMENT OF DEFENSE 90-DAY STUDY RESPONSE

Lt. Gen. Donald L. Cromer, USAF,
Space Systems Division
Col. Brent Collins, USAF,
Space Systems Division
Col. Mike Mushala, USAF, Industrial
College of Armed Forces, R.D.

DEPARTMENT OF ENERGY BRIEFING

Fenton Carey, Headquarters
Earl Wahlquist,
Space and Defense Power Systems
Dick Widrig,
Pacific Northwest Laboratory
Jim Blacic,
Los Alamos National Laboratory
Reinhold Mann,
Oak Ridge National Laboratory
Robert Borchers, Lawrence Livermore
National Laboratory
S. Peter Gary,
Los Alamos National Laboratory
John Vitko, Sandia Laboratory
A. Denison, Idaho National Laboratory
William F. Dove, Ph.D., Fusion Program
Office
Matesh Varma, Ph.D., Office of Health
and Environmental Research
Richard J. Serbu, Office of Safety
Appraisals
Otto Buck, Ames Laboratory
William J. Shack,
Argonne National Laboratory
Jack Cook,
Oak Ridge National Laboratory

DEPARTMENT OF THE INTERIOR BRIEFING

Peter Chamberlain,
U.S. Bureau of Mines
Michael Carr, U.S. Geological Survey
Dr. Terry Triffet, Indigenous Space
Materials Utilization Panel
Corrine Buoni, Science Applications
International Corporation

ECONOMICS & SPACE EXPLORATION INITIATIVE

Fred Leykan, Washington Institute
Richard Cohen, Washington Institute

ELECTRIC PROPULSION

Dave Beyers, NASA, Lewis Research
Center
Chuck Eldred, NASA,
Langley Research Center
Irv Sumner, NASA,
Lewis Research Center
John Smith, NASA,
Lewis Research Center

EVOLUTION OF EXISTING SYSTEMS FOR LUNAR TRANSPORTATION

Scott Benson, NASA,
Lewis Research Center
Norm Brown, NASA,
Marshall Space Flight Center
Bill Huber, NASA,
Marshall Space Flight Center

EXTRAVEHICULAR ACTIVITY SYSTEM APPLICABILITY

John Bouvier, Ocean Systems
Engineering
Bruce Caldwell, Ocean Systems
Engineering
Mike Gerhardt, Ocean Systems
Engineering

F-1 ENGINE (SPACE SHUTTLE MAIN ENGINE)/ROCKWELL INTERNATIONAL

Peter K. Cocolis, Rockwell International,
Rocketdyne Division
Paul E. Coffman, Rockwell
International, Rocketdyne Division
Henry Minami, Rockwell International,
Rocketdyne Division

FINAL RAND REPORT

Col. John Friel, USAF (Ret.), RAND,
Computer Information Systems
Elwyn Harris, RAND,
Defense Planning and Analysis
Dan Herman

FOOD AND LUNAR HABITATS

Charles Bourland, NASA,
Johnson Space Center
Nathan Moore, NASA,
Johnson Space Center

GENERAL DYNAMICS / INDUSTRY PRESENTATION

Paul Bialla, Space Systems Division,
General Dynamics
Howard Bonesteel, Space Systems
Division, General Dynamics
Greg Gilmore, General Dynamics
Corporation
Hal Rietveld, General Dynamics
Corporation

GENERAL DYNAMICS / SINGLE STAGE-TO-ORBIT

Bob Ford, General Dynamics
Space Systems Division
Dan Heald, General Dynamics
Space Systems Division
John Karas, General Dynamics
Space Systems Division
Tom Kessler, General Dynamics
Space Systems Division

GRUMMAN / INDUSTRY PRESENTATION

Bob Puff, Grumman Corporation,
Space Systems Division
Jerry Bostick, Grumman Corporation,
Space Systems Division
John Mockovciak, Grumman
Corporation, Space Systems Division

HEAVY LIFT LAUNCH VEHICLE DESIGN-DEPARTMENT OF DEFENSE

Dennis Granato,
Office of the Secretary of Defense
Gene Sevin, Ph.D.,
Office of the Secretary of Defense

HUGHES / INDUSTRY PRESENTATION

Will Turk, Hughes Aircraft Company,
Advanced Government Programs
Jerry Adams, Hughes Aircraft
Company, Advanced Government
Programs

HUMAN EXPLORATION OF THE MOON & MARS, SUMMARY OF THE 90-DAY STUDY

Mark Craig, NASA Headquarters

HUMAN MISSIONS TO MARS

Carl Sagan, Ph.D., Cornell University

IBM / INDUSTRY PRESENTATION

George Nossaman, IBM, Federal
Systems
Ned Yelverton, IBM, Federal Systems

IN-SPACE OPERATIONS

A. Meintel, NASA,
Langley Research Center
John Dorsey, NASA,
Langley Research Center

INTEGRATED SPACE TRANSPORT

Bill Huber, NASA,
Marshall Space Flight Center
Norman Brown, NASA,
Marshall Space Flight Center
Phil Sumrall, NASA,
Marshall Space Flight Center

INTRODUCTION TO COMPARISON OF NUCLEAR AND CHEMICAL PROPULSION FOR HUMAN FLIGHT TO MARS

R.G. Finke, Institute for Defense
Analyses, Science and Technology
Division

LASER PROPULSION AND "MOONGUN"

Kare Jordin, Department of Energy,
Lawrence Livermore National
Laboratory

LAUNCH VEHICLES/LAUNCH SITE

Harold L. Smith, NASA,
Headquarters
David C. Moja, NASA,
Kennedy Space Center
Leland P. Scott, Lockheed Space
Operations Company
William O. Goldsby, Jr., NASA,
Kennedy Space Center

LIFESAT PROGRAM

Frank M. Sulzman, Ph.D.,
NASA Headquarters

LOCKHEED / BECHTEL / SAIC INDUSTRY PRESENTATION

A. Guastaferrro, Lockheed,
Space Systems Division
Jack F. Houle, Lockheed,
Space Systems Division

John Niehoff, Science Applications
International Corporation,
Space Science Operations
Neil Hutchinson, Science Applications
International Corporation
Carleton H. Jones, Bechtel,
Applied Physics Group
Thomas E. Styczynski, Lockheed,
Space Systems Division

LUNAR & MARS EXPLORATION MISSIONS

Ray Hallett, General Electric Aerospace

LUNAR CAMPSITE CONCEPT SUPPORTING MATERIAL

Carl M. Case, The Boeing Company

LUNAR MINING

Gerald Kulcinski,
University of Wisconsin

LUNAR OBSERVATION

Jack O. Burns, Ph.D.,
Department of Astronomy,
New Mexico State University

LUNAR SCIENCE & ENVIRONMENT

Jeffrey Taylor, Ph.D.,
University of Hawaii
Robert Wilson, Ph.D., American
Telephone and Telegraph Company,
Bell Labs
Larry Haskin, Ph.D., Washington
University

LUNAR TRANSPORTATION FACILITIES & OPERATIONS STUDY

Lyle Barney, McDonnell Douglas
Space Sciences Corporation
Art Glabb, McDonnell Douglas
Space Sciences Corporation
Jeff Traylor, McDonnell Douglas
Space Sciences Corporation
Rex Shaffer, McDonnell Douglas
Space Sciences Corporation

MANAGEMENT MODELS

Michael D. Griffin, Ph.D., Department of
Defense / Strategic Defense Initiative
Organization

MANNED SPACE / LUNAR ACTIVITY

Captain John Young, USN (Ret.),
NASA, Johnson Space Center

MARS SCIENCE / ENVIRONMENT

Ronald Greeley, Ph.D.,
Arizona State University
Andrew Ingersoll, Ph.D.,
California Institute of Technology
Donald DeVincenzi, Ph.D., NASA,
Ames Research Center

**MARTIN MARIETTA / INDUSTRY
PRESENTATION**

Roger Chamberlain, Martin Marietta,
Civil Space Communications
Division
Ben Clark, Martin Marietta, Civil Space
Communications Division
Robert Zubrin, Martin Marietta, Civil
Space Communications Division

**MATERIALS ISSUES,
DEPARTMENT OF ENERGY**

Otto Buck, Department of Energy,
Ames Laboratory
Robert J. Gottschall, Department of
Energy, Headquarters
William J. Shack, Department of Energy,
Argonne National Laboratory

**McDONNELL DOUGLAS
PRESENTATION / MAXIMUM
ECONOMIC FEEDBACK**

W. H. Siegfried, McDonnell Douglas
Space Systems Company

**McDONNELL DOUGLAS / INDUSTRY
PRESENTATION**

John Aldred, Eagle Engineering
Hal Emigh, McDonnell Douglas,
Space Systems Company
Ray Hallett, General Electric Aerospace,
Astrospace Division
Michael Knasel, Ph.D., Morrison-
Knudsen, Automated Systems
Division
James Spaeth, McDonnell-Douglas,
Space Systems Company
Jerry Wald, Honeywell Incorporated,
Systems and Research Center

**McDONNELL DOUGLAS / SINGLE
STAGE-TO-ORBIT**

William Gaubatz, Ph.D., McDonnell
Douglas, Space Systems Company
Pete Conrad, McDonnell Douglas,
Space Systems Company

MIR SPACE STATION OPERATIONS

General Jean-Loup Cretien, FAF,
Director of Astronauts, Centre
National d'Etudes Spatiales

NASA EDUCATION PROGRAM

Robert Brown, Ph.D.,
NASA Headquarters

**NASA UPDATE ON THE SPACE
EXPLORATION INITIATIVE**

Peter Ahlf, NASA Headquarters
Arnold Aldrich, NASA Headquarters
Norman Chaffee, NASA,
Johnson Space Center
Glenn E. Cunningham, NASA,
Jet Propulsion Laboratory
Ron Harris, NASA Headquarters
Don Hei, NASA,
Goddard Space Flight Center
Bill Huber, NASA,
Marshall Space Flight Center
Dick Lacashire, NASA,
Lewis Research Center
John C. Mankins, NASA Headquarters
Al Miller, NASA Headquarters
Marc Murbach, NASA,
Ames Research Center
Brian Pritchard, NASA,
Langley Research Center
Barney Roberts, NASA,
Johnson Space Center
Frank M. Sulzman, NASA
Headquarters

NATIONAL AEROSPACE PLANE

H. Lee Beach, Ph.D.,
NASA Headquarters

**NATIONAL PROGRAM OFFICE /
POLARIS PROGRAM MODEL**

Captain Robert Freitag, USN (Ret.)
Captain Chester M. Lee, USN (Ret.),
Spacehab

NUCLEAR ROCKET TESTING

Earl Wahlquist, Department of Energy
Space and Defense Power Systems
Richard J. Serbu, Office of Safety
Appraisals
Bill Kirk, Los Alamos National
Laboratory
John Martinell, Idaho National
Laboratories
Jack Ramsthaler, Idaho National
Laboratories

**NUCLEAR THERMAL REACTORS—
ROCKWELL INTERNATIONAL /
WESTINGHOUSE**

Bob Anderson, Rockwell International,
Rocketdyne Division
Jim Bates, Rockwell International,
Rocketdyne Division
Dave Black, Westinghouse,
Government Operations
Stanley V. Gunn, Rockwell
International, Rocketdyne Division
Richard Johnson, Rockwell
International, Rocketdyne Division
John Wett, Westinghouse, Advanced
Energy Systems Department

ORBITAL MECHANICS

Doug Kirkpatrick, NASA Headquarters

PAST COMMISSION STUDIES

Leonard David, National Space Society

**PATHFINDER PROJECT PLAN—
EXTRAVEHICULAR ACTIVITY SUIT**

Bruce W. Webbon, Ph.D., NASA,
Ames Research Center

PLANET SURFACE SYSTEMS

Barney B. Roberts, NASA,
Johnson Space Center
John F. Connolly, NASA,
Johnson Space Center

**PLANET SURFACE SYSTEMS
TECHNOLOGY / ADVANCED
DEVELOPMENT**

Gene Grush, NASA,
Johnson Space Center

**PLANET SURFACE SYSTEMS:
INTEGRATION**

Barney B. Roberts, NASA,
Johnson Space Center

**PLANET SURFACE SYSTEMS:
OPERATIONS**

Garet Nenninger, NASA,
Johnson Space Center

**PLANET SURFACE SYSTEMS AND
HUMAN HABITATION**

Robert Bond, NASA,
Johnson Space Center
Jeri W. Brown, NASA,
Johnson Space Center
Paul D. Campbell, Lockheed,
Engineering and Science Program
Nathan Moore, NASA,
Johnson Space Center
David Petri, NASA,
Johnson Space Center
Tom Polette, Lockheed,
Engineering and Science Program
Barney B. Roberts, NASA,
Johnson Space Center

**POLITICAL SCIENCE & SPACE
EXPLORATION INITIATIVE**

John Logsdon, Ph.D.,
George Washington University

**POWER BEAMING / NUCLEAR
THERMAL ROCKET / NUCLEAR
ELECTRIC PROPULSION-CHEMICAL
TRADE-OFFS**

Edmund P. Coomes, Department of
Energy, Pacific Northwest Laboratory
Jeff Dagle, Department of Energy,
Pacific Northwest Laboratory
Ben Johnson, Department of Energy,
Pacific Northwest Laboratory

**PRESSURE PHYSIOLOGY-LIFE
SCIENCES**

Arnauld Nicogossian, M.D.,
NASA Headquarters

**PRESSURIZED ROVER FOR LUNAR
EXPLORATION**

Brand Griffin, The Boeing Company

**PROGRAM OVERVIEW—
ADVANCED LAUNCH
DEVELOPMENT PROGRAM**

Col. Roger T. Colgrove, USAF,
Space Systems Divisions

PROPULSION

Ned Hannum, NASA,
Lewis Research Center
Frank Berkopec, NASA,
Lewis Research Center
Stan Borowski, NASA,
Lewis Research Center
Larry Cooper, NASA,
Lewis Research Center

PROPULSION ISSUES

Jim Kelley, NASA,
Jet Propulsion Laboratory
Joel Sercel, NASA,
Jet Propulsion Laboratory

RADIOBIOLOGY

Walter Schimmerling, Lockheed
Engineering and Science Company
William Gilbreath, NASA Headquarters

**RAILGUN/EARTH TO ORBIT
LAUNCH (ETOL) FOR THE SPACE
EXPLORATION INITIATIVE**

Glenn Rolander, Ph.D.,
Science Applications
International Corporation

ROBOTIC EXPLORATION MISSIONS

Glenn E. Cunningham, NASA,
Jet Propulsion Laboratory
Wesley Huntress, Ph.D.,
NASA Headquarters
Roger Bourke, Ph.D., NASA,
Jet Propulsion Laboratory
Carl Pilcher, Ph.D.,
NASA Headquarters

**ROCKETDYNE F-1: 300K TO LOW
EARTH ORBIT**

Bob Anderson, Rocketdyne Division,
Rockwell International
Jim Bates, Rocketdyne Division,
Rockwell International
Paul Coffman, Rocketdyne Division,
Rockwell International
Henry Minami, Rocketdyne Division,
Rockwell International

**ROCKWELL / INDUSTRY
PRESENTATION**

George Merrick, Rockwell International
Larry Lewis, Rockwell International,
Space Systems Division
Ed Repic, Rockwell International,
Space Systems Division

**ROCKWELL / SINGLE
STAGE-TO-ORBIT**

Jim Berry, Rockwell International,
North American Aircraft
Gary Briley, Rockwell International,
Rocketdyne Division
H. S. Greenberg, Rockwell International,
Space System Division
R. Gulcher, Rockwell International,
North American Aircraft
Mike Hampson, Rockwell International,
Rocketdyne Division

SEALAR PROGRAM

Peter Wilhelm, U.S. Naval Research
Laboratory

**SHUTTLE FOLLOW-ON
TECHNOLOGY**

Peter Kysor, Institute of Defense
Analysis, Science Technology
Division

SOLAR POWERED SATELLITES

Jerry Hanley, Rockwell International
Corporation
Rand Simberg, Rockwell International
Corporation

**SOVIET MANNED SPACEFLIGHT
AND PLANETARY PROGRAMS**

Major General Alexi Leonov, SAF,
Chief of Cosmonauts

SPACE COSTING METHODS

Joe Hamaker, NASA,
Marshall Space Flight Center
Humboldt C. Mandell, Jr., Ph.D.,
NASA, Johnson Space Center
Kelley Cyr, NASA,
Johnson Space Center

SPACE ENVIRONMENT

David Bohlin, NASA Headquarters
Don Kessler, NASA,
Johnson Space Center

SPACE EXPLORATION INITIATIVE EDUCATION

Richard Reeves, NASA Headquarters

SPACE LIFE SCIENCES OVERVIEW

Arnauld Nicogossian, M.D.,
NASA Headquarters
Carolyn Huntoon, Ph.D., NASA,
Johnson Space Center
Carl Pilcher, Ph.D.,
NASA Headquarters

SPACE OPERATIONAL SYSTEMS / ARTIFICIAL INTELLIGENCE

Bryant Cruse, Talarian Corporation

SPACE SOLAR POWER

Joe Scifers, Ph.D., Thomas/Scifers Inc.

SPACE STATION FREEDOM REDESIGN/ TRANSPORTATION NODE

Col. Edwin E. Aldrin, USAF (Ret.)

SPACE STATION FREEDOM STATUS

Richard Kohrs, NASA Headquarters
Earle K. Huckins III, Ph.D.,
NASA Headquarters

SPACE: POLITICAL / SOCIAL ISSUES

Michael Fulda, Ph.D., Institute for Social
Science Study of Space, and Fairmont
State College

STRUCTURES

Robert J. Hayduk, NASA Headquarters
Murray Hirschbein,
NASA Headquarters
Samuel L. Veneri,
NASA Headquarters

SURFACE SYSTEMS: EMPLACEMENT STRATEGIES

Larry Toups, NASA,
Johnson Space Center
Les Pienazek, NASA,
Johnson Space Center

TELECOMMUNICATIONS, NAVIGATION & INFORMATION MANAGEMENT (TNIM)

Albert R. Miller, Ph.D.,
NASA Headquarters
Justin R. Hall, NASA, Jet Propulsion
Laboratory

TETHERS

Ivan Bekey, Ph.D.

TEXAS INSTRUMENTS / INDUSTRY PRESENTATION

Dean Collins, Defense Systems and
Electronics Group
Gary Howell, Defense Systems and
Electronics Group
Russ Logan, Defense Systems and
Electronics Group
Tom McDaniel, Defense Systems and
Electronics Group

THE RIDE REPORT

Alan Ladwig

THIOKOL CORPORATION / INDUSTRY PRESENTATION

Peter Evanoff, Thiokol Corporation,
Space Programs

TRAINING OPERATIONS FOR LONG DURATION SPACEFLIGHT

Frank E. Hughes, NASA,
Johnson Space Center

TRAJECTORIES: MARS QUICK TRIP TIMES AND MARS MISSION DESIGNS

Edgar C. Lineberry, NASA,
Johnson Space Center

TRW/INDUSTRY PRESENTATION

Joe Freitag, TRW,
Advanced Technology Division
Jim Hieatt, TRW,
Federal Systems Division
J. Max Watson, TRW,
Federal Systems Division
R. Gordon Williams, TRW,
Federal Systems Division

TRW / PROPULSION ISSUES

Lee Dailey, TRW,
Advanced Technology Division
Joe Freitag, TRW,
Space Technology Group
Jim Hieatt, TRW,
Space Technology Group
Bob Noblitt, TRW
Bob Sackheim, TRW,
Advanced Technology Division

UNITED TECHNOLOGIES CORPORATION / INDUSTRY PRESENTATION

Jim Hix, United Technologies
Corporation
Tom Latham, United Technologies
Corporation, Research Center
Randy Parsley, United Technologies
Corporation, Pratt & Whitney
Phil LaForce, United Technologies
Corporation, Chemical Systems
Division
Tim Falvey, United Technologies
Corporation, Hamilton Standard
Division
Charles Lockerby, United Technologies
Corporation, Carrier Division
Jay Stedman, United Technologies
Corporation, Internationaal Fuel
Cells Division
Joe Parker, United Technologies
Corporation, United States
Boosters, Inc.
Bill Rothschild, United Technologies
Corporation, Pratt & Whitney

VISTA: A VEHICLE FOR INTERPLANETARY SPACE TRANSPORTATION APPLICATIONS

Nate Hoffman, Ph.D.,
Department of Energy, Lawrence
Livermore National Laboratory
Charles D. Orth, Ph.D.,
Department of Energy, Lawrence
Livermore National Laboratory

Apsidal - Relating to the point in the elliptical orbit of a moon, a planet, etc. nearest to (lower apsis), or farthest from (higher apsis), the gravitational focus point.

Beneficiation - The process of concentrating useful (ore) materials from surface regolith (soil).

Conjunction - An astronomical alignment where two bodies appear in the same direction as seen from the Earth. The condition of two or more celestial bodies, especially a planet with the sun, located along the same celestial longitude when viewed from Earth.

Cryogenic - Of or pertaining to liquified gases or very low temperature (3 to 100 degrees Kelvin; -276 to -76 degrees Celsius; -285 degrees Fahrenheit) materials.

Deuterium - An isotope of hydrogen whose nucleus contains one proton and two neutrons. Used in nuclear fusion reactions.

Eccentricity - For a given conic section, a mathematical constant that is the ratio of the distances from any point of the conic section to a focus and the corresponding directrix.

Heliocentric - Having or regarding the Sun as the center.

Helium-3 - An isotope of helium whose nucleus contains two protons and one neutron. Used in nuclear fusion reactions.

Ilmenite - A titanium and iron oxide mineral, abundant in some deposits on the Moon; useful in the production of oxygen from lunar regolith in certain processes.

Lagrange Points - Points in space where the gravitational attractions of two or more bodies cancel out so that an object placed there will remain relatively motionless.

Lidar - An instrument using transmitted and reflected laser light for detecting objects or atmospheric particles and determining their position, concentration, etc.

Opposition - An astronomical alignment where two bodies appear in opposite directions as seen from the Earth. The position of two celestial bodies when their celestial longitudes differ by 180 degrees, especially the position of a planet or the Moon when it is in opposition with the sun.

Parsec - A unit of astronomical distance equal to 3.26 light years or 3.09×10^{13} km.

Periapsis - The nearest point to the gravitational center in the orbit of any satellite.

Phase Angle - The angle between two planets at a definite point in their orbits as seen from the Sun.

Regolith - Unconsolidated residual or transported material that overlies the solid rock on the Earth, Moon or a planet.

REM (Radiation Equivalent Man) - A dosage of radiation absorbed by a human that takes into account the biological effects of different types of radiation.

Telepresence - The projection of human senses (e.g., vision, touch) and physical powers of locomotion and manipulation through a robot at a remote location.

Tritium - An isotope of hydrogen whose nucleus contains one proton and three neutrons. Used in nuclear fusion reactions.

BIBLIOGRAPHY

- American Institute of Aeronautics and Astronautics. "Final Report to the Office of Aeronautics, Exploration and Technology National Aeronautics and Space Administration on Assessment of Technologies for the Space Exploration Initiative (SEI)." Washington, DC: December 31, 1990.
- American Institute of Physics. Conference Proceedings 203 - "High-Energy Astrophysics in the 21st Century." Taos, NM: December 11-14, 1989.
- American Institute of Physics. Conference Proceedings 202 - "Physics and Astrophysics from a Lunar Base." Stanford, CA: December 1, 1989.
- American Institute of Physics. Conference Proceedings 207 - "Astrophysics from the Moon." Annapolis, MD: February 5-7, 1990.
- American Society of Civil Engineers. "Proceedings of SPACE 90." Albuquerque, NM: April 22-26, 1990.
- Angelo, J. and Buden, D. *Space Nuclear Power*. Malabar, FL: Orbit Book Co., 1985.
- Babb, G.R. and W. R. Stump. "Use of Lunar Produced Propellants for Manned Mars Missions." *Manned Mars Missions*. NASA Publication M002. Washington, DC: June 1986.
- Beckstrom, J. et al. "EVA Systems Level IV Report for Human Exploration Initiative 90-Day Study." NASA, Johnson Space Center, Crew and Thermal Systems Division Report. Houston, TX: March 30, 1990.
- Bennett, G.L., et al. "Enhancing Space Transportation: The NASA Program To Develop Electric Propulsion." NASA Technical Memorandum 4244. Washington, DC: October 1990.
- Bennett, Gary L. "Historical Overview of the U.S. Use of Space Nuclear Power." *Space Power*. Vol. 8, No. 3, IAF-ICOSP89. Cleveland, OH: 1989.
- Boher, Kuh, and Bohl. "The Behavior of Fission Products During Nuclear Rocket Reactor Tests." Eighth Symposium on Space Nuclear Power Systems. Orlando, FL: January 6-10, 1991.
- Bohl, Hanson, and Edeskuty. "Planning for Ground Testing of Nuclear Rocket Engines with Today's Environmental Awareness." AIAA paper 90-2517. Twenty-sixth Joint Propulsion Conference. Orlando, FL: July 16-18, 1990.
- Budden N.A. "OSSA Science Objectives and Introduction to Architectures." NASA, Johnson Space Center Exploration Science Working Group Report. Houston, TX: August 1, 1990.
- Budden N.A. "Science Development and Payloads: Exploration Emphasis Architecture." NASA, Johnson Space Center Lunar and Mars Exploration Programs Office Review Board Report. Houston, TX: July 16-17, 1990.
- Budney C.J. "Science Engineering Analysis 1989 Final Instrument Catalog." NASA, Jet Propulsion Laboratory, Document D-6836. Pasadena, CA: 1989.
- Burke, Bernard F. "Astrophysics from the Moon." *Science*. Vol. 250, December 7, 1990.
- Burns, Jack O. et al. "Observatories on the Moon." *Scientific American*. Vol. 262, No. 3. March 1990.
- C. R. Chapman and D. Morrison. *Cosmic Catastrophes*. New York, NY: Plenum Press, 1989.

- Chaffee, Norman H. "Preliminary Heavy Lift Launch Vehicle (HLLV) Requirements for the Space Exploration Initiative." NASA, Johnson Space Center, Code XE Memorandum. Houston, TX: January 11, 1991.
- Clark, J. "Nuclear Thermal Propulsion, A Summary of Concepts." Nuclear Thermal Propulsion Summer Workshop. Cleveland, OH: July 10-12, 1990.
- Cohen R.H. "SEI Science Payloads: Descriptions and Delivery Requirements." NASA, Jet Propulsion Laboratory, Document D-7281. Pasadena, CA: 1990.
- Collins, Michael. *Mission to Mars*. New York, NY: Grove Press, Inc., 1990.
- Committee on Lunar and Planetary Exploration (COMPLEX). "Update to Strategy for Exploration of the Inner Planets." Washington, DC: National Academy Press, 1990.
- Damon, Thomas D. *Introduction to Space*. Malabar, FL: Orbit Book Co. Inc., 1989.
- Davis, Donald R., William K. Hartmann, Alan Friedlander, John Collins, John Niehoff, Tom Jones. "The Role of Near-Earth Asteroids in the Space Exploration Initiative." SAIC-90/1464. Washington, DC: September 1990.
- Dearien, J.A. and J.F. Whitbeck. "Multimegawatt Nuclear Systems for Space Power." 22nd Intersociety Energy Conversion Engineering Conference. Philadelphia, PA: August 1987.
- Deming, W. Edwards. *Out of the Crisis*. Cambridge, MA: MIT Center for Advanced Engineering Study, 1989.
- Department of Defense. "A Quest for Excellence." A Final Report to the President by the President's Blue Ribbon Commission on Defense Management. Washington, DC: June 1986.
- Department of Defense. "Report to the President on Defense Management." Washington, DC: July 1989.
- Department of Defense. "White Paper on the Department of Defense and the Congress." Washington, DC: January 1990.
- Department of Defense. "White Paper on Acquisition Streamlining for the Space Exploration Initiative." Washington, DC: 1990.
- DeVincenzi, D.L. and H.P. Klein. "Exobiology Science Objectives at a Lunar Base." Preprint manuscript. October 1990.
- Eagle Engineering. "Mobile Surface Applications Traverse Vehicle (MOSAP)," *Lunar Surface Transportation Systems Conceptual Design*. Eagle Engineering Report 88-188. Houston, TX: 1988.
- Eppler D. "Lighting Constraints to Lunar Surface Operations." NASA, Johnson Space Center, Lunar and Mars Exploration Office Report. Houston, TX: 1990.
- Executive Order 12675, "Establishing the National Space Council." Washington, DC: April 30, 1989.
- Fairchild, Kyle and Wendell Mendell. "Report of the In Situ Resources Utilization Workshop." NASA, Johnson Space Center, Conference Publication 3017. Houston, TX: 1988.

- Foreign Policy Institute and The Center for Strategic and International Studies. "Making Defense Reform Work." Washington, DC: November 1988.
- Frisbee, et al. "Advanced Propulsion Options for the Mars Cargo Mission." AIAA paper 90-1997. Twenty-sixth Joint Propulsion Conference. Orlando, FL: July 16-18, 1990.
- GAO/NSIAD. "Fleet Ballistic Missile Program-Executive Summary." GAO/NSIAD-90-160. Washington, DC: Government Printing Office, 1990.
- Geer, Charles W. (Program Mgr.), et. al. *Man-System Integration Standards (Vol. 2)*. NASA STD 3000. Washington, DC: March 1987.
- Gervin, Schoenberg, and Rej. "Preliminary Scoping Studies for Nozzle-Based Coaxial Plasma Thrusters." Eighth Symposium on Space Nuclear Power Systems. Albuquerque, NM: January 7-10, 1991.
- Gray, Henry F. "Vacuum Microelectronics; The Electronics of the 21st Century," *Nano Electronics. Electro/89*, Session 8. Washington, DC: April 11-13 1989.
- Greeley, Ronald. *Mars Landing Sites Catalog*. Tempe, AZ: Arizona State University, Department of Geology, 1990.
- Hartman, R.F. "Current Status of MOD-RTG Program." Twenty-third Intersociety Energy Conversion Engineering Conference. Denver, CO: August 1988.
- Hawkins, Willis; Robert Jastrow; William Nierenberg; and Frederick Seitz. "New Directions in Space—A Report on the Lunar and Mars Initiatives." Washington, DC: George C. Marshall Institute, 1990.
- Helin, E. and R.S. Dunbar. "Search Techniques for Near-Earth Asteroids." *Vistas in Astronomy* 33. New York, NY: 1990.
- Herrera, A. and L.D. Toops, et. al. "90 Day Study Reference Architecture Description." NASA 9-17900. Houston, TX: Lockheed, January 1990.
- Hickman, J.M, et al. "Solar Electric Propulsion for Mars Transport Vehicles." NASA Technical Memorandum 103234. Washington, DC: September 1990.
- Jet Propulsion Laboratory and Fairborn Observatory. "Workshop on Small Robotic Telescopes on the Moon" from conference on Robotic Astronomy at the Lunar Outpost. Tuscon, AZ: November 4, 1990.
- Jet Propulsion Laboratory. "SEI Science Payloads: Descriptions and Delivery Requirements." FY-90 Mid-Year Draft, JPL D-7281. Pasadena, CA: April 25, 1989.
- Jet Propulsion Laboratory. "SEI Science Payloads: Descriptions and Delivery Requirements." JPL D-7955. Pasadena, CA: October 31, 1990.
- Johnson, Stewart W. *Criteria for the Design of Structures for a Permanent Lunar Base*. Doctoral Thesis. Urbana, IL: University of Illinois, 1964.
- Johnson, Stewart W., and John P. Wetzel. "Engineering, Construction and Operations in Space," *American Society of Civil Engineers Space ('88) Proceedings*. New York, NY: 1988.
- Johnson, Stewart W., and John P. Wetzel. "Engineering, Construction and Operations in Space," *American Society of Civil Engineers Space ('90) Proceedings*. New York, NY: 1990.

- Kosmo, Joseph J., et al. "Development of the NASA ZPS Mark III 57.2-kN/m² (8.3 psi) Space Suit." SAE Technical Paper 881101. Eighteenth Intersociety Conference on Environmental Systems. San Francisco, CA: July 11-13, 1988.
- Kosmo, Joseph J. "Design Considerations for Future Planetary Space Suits." SAE Technical Paper 901428. Twentieth Intersociety Conference on Environmental Systems. Williamsburg, VA: July 9-12, 1990.
- Kosmo, Joseph J. Personal correspondence. November 1990.
- Kurland, Richard, and Paul Stella. "Status of Advanced Photovoltaic Solar Array Program" Twenty-third Intersociety Energy Conversion Engineering Conference. Denver, CO: Aug. 1988.
- Kuznetz, Lawrence H.. "Space Suits and Life Support Systems for the Exploration of Mars." NASA, Ames Research Center Report Moffett Field, CA: Undated.
- Laursen, Eric F. (Lockheed) , Carlton H. Jones, Jr. (Bechtel), and John Niehoff (Science Applications International Corporation). "Common Base Surface Facilities for the SEI." IAF-90-441. Dresden, GDR: October 1990.
- Lawrence Livermore National Laboratory. "The Great Exploration Plan for the Human Exploration of the Solar System." Lawrence Livermore National Laboratory, Document No. Physics Brief 90-402. Livermore, CA: January 17, 1990.
- Lewis, J.S. and R.A. Lewis. *Space Resources: Breaking the Bonds of Earth*. New York, NY: Columbia University Press, 1987.
- Life Support Management Working Group. *Final Report*. Washington, DC: June 2, 1989.
- Logistics Management Institute. *Regulatory Relief: Simplifying and Eliminating Contract Clauses, Vol. 1*. Bethesda, MD: LMI, 1989.
- Lord, Douglas. *Spacelab—An International Success Story*. NASA SP 487. Washington, DC: 1987.
- Los Alamos National Laboratory. "Low-Thrust Rocket Trajectories." LA-10625-MS. Los Alamos, NM: January 1986.
- Lunar Exploration Science Working Group (LEXSWG). "A Planetary Science Strategy for the Moon." Unpublished draft manuscript. September 1990.
- Lunar Geoscience Observer Science Workshop members. "Contributions of a Lunar Geoscience Observer (LGO) Mission to Fundamental Questions in Lunar Science." Dallas, TX: Southern Methodist University, Dept. of Geological Sciences, March 1986.
- Lunar Mars Exploration Program Office. "Exploration Emphasis Architecture White Paper." NASA, Johnson Space Center Report. Houston, TX: 1990.
- Mandell, Humboldt C. Jr. "The Space Exploration Initiative: One Prescription for Success" (Third Draft). NASA internal document. Washington, DC: October 1990.
- Mars Science Working Group. "A Strategy for the Scientific Exploration of Mars." Unpublished draft manuscript. Houston, TX: September, 1990.
- Mendell, Wendell. *Lunar Bases*. Houston, TX: Lunar Planetary Institute, 1985.
- Miller, Albert R. and Justin R. Hall. "Telecommunications, Navigation and Information Management." Presentation to the Synthesis Group. Crystal City, VA: August 29, 1990.

- Mondt, J.F. "Development Status of the SP-100 Power System." Twenty-fifth Joint Propulsion Conference Paper No. AIAA-89-2591. Monterey, CA: July 1989.
- NASA Science Integration/Lunar Mars Exploration Program Office: "Additional Information for Team Oscar: Lunar Observation Waypoint Telescope." Memorandum. Houston, TX: October 26, 1990.
- NASA Office of Exploration. *Technical Report, FY 1988, Vol. II, 4.2 Extraterrestrial Propellant Leveraging*. Washington, DC: 1988.
- NASA Office of Exploration. "Lunar Liquid Oxygen Leverage," *Exploration Studies Technical Report, Vol. I: Mission and Integrated Systems*. NASA Technical Memorandum 4170. Washington, DC: 1989.
- NASA, Ames Research Center. *Project Pathfinder, EVA/Suit Project Plan*. Moffett Field, CA: October 1988.
- NASA, Office of Inspector General. "Results of Inquiry (AA-80-002): Extravehicular Mobility Unit." NASA Contract NAS9-15150. Washington, DC: December 18, 1980.
- NASA. "90 Day Study Data Book." NASA internal report. Washington, DC: December 1989.
- NASA. "Earth Approaching Asteroids as Targets for Exploration," *Asteroids: An Exploration Assessment*. NASA Conference Publication 2053. Washington, DC: 1978.
- NASA, Marshall Space Flight Center. "Lunar Astrophysics Observatories." NASA internal document. Huntsville, AL: 1990.
- NASA. "Report of the 90 Day Study on Human Exploration of the Moon and Mars." NASA internal report. Washington, DC: November 20, 1989.
- NASA. "Report of the Life Sciences Working Group." NASA internal report. Washington, DC: June 2, 1989.
- NASA. "Skylab Experiment M 487: Habitability/Crew Quarters." NASA, Johnson Space Center, TM X-58163. Houston, TX: 1975.
- NASA. "A Lunar Far-side Very Low Frequency Array." NASA Conference Publication 3039. Washington, DC: 1988.
- NASA. "Exploration Studies Technical Report." *FY 1989 Annual Report*. Washington: NASA, 1989.
- NASA. "Habitation and Human Systems for the 90 Day Study (Level IV Report)". NASA-APO-SDB. Johnson Space Center 24398. Houston, TX: March 30, 1990.
- NASA. "Lunar Outpost Astrophysics Program Summary." NASA internal document. Washington, DC: January 1990.
- NASA. NASA Conference Publication 2489 - "Future Astronomical Observations from the Moon." Washington, DC: January 10, 1986.
- NASA. "NASA's Need for Advanced Nuclear Power Source." Office of Aeronautics and Space Technology. Washington, DC: January 1989.
- NASA. *Report of the Advisory Committee on the Future of the U.S. Space Program*. Washington, DC: 1990.

- NASA. *Report of the NASA Lunar Energy Enterprise Case Study Task Force*. NASA Technical Memorandum 101652. Washington, DC: 1989.
- NASA, Lewis Research Center. "Electric Propulsion for the Space Exploration Initiative." Presentation to the Synthesis Group. Arlington, VA: December 3, 1990.
- NASA, Lewis Research Center. "Nuclear Propulsion Project Plan (Draft)." Cleveland, OH: July 27, 1990.
- Office of the Chief Engineers, Dept. of Army. *Lunar Construction Vol 1*. NASA DPR W-11430. Washington, DC: April 1963.
- Office of the Chief Engineers, Dept. of Army. *Lunar Construction, Vol. 2 with Summary*. NASA DPR W-11430. Washington, DC: April 1963.
- Osborne, R.S., and Tynan Williams Jr. "AIS/AIAA Variable Geometry and Expandable Structures Conference." AIAA Paper #71-399. Anaheim, CA: April 1971.
- Peirce, B., "The ENABLER; A Nuclear Thermal Propulsion System." SEI Outreach Input #100933. July 1990.
- Petri, D.A., Cataldo, R.L., and J.M. Bozek. "Power System Requirements and Definition For Lunar and Mars Outposts." Twenty-fifth Intersociety Energy Conversion and Engineering Conference. Reno, NV: August 1990.
- Pieniasek, L. (Lockheed), Roberts, B. (Mgr. PSS, JSC). "Surface Systems Supporting a Lunar Base, AIAA-90-0423." Houston, TX: January, 1990.
- Pluta, P.G., M.A. Smith, and D.N. Matteo. "SP-100, A Flexible Technology for Space Power from 10s to 100s of kWe." Twenty-fourth Intersociety Energy Conversion Conference. Washington, DC: August 1989.
- Reinhardt, Allen. "Systems Analysis of the AX-5 Space Suit." NASA, Ames Research Center Report. Moffett Field, CA: February 9, 1990.
- Roberts, Carol A. and John T. Lynch. "Antarctica as an Analog to the Moon and Mars." National Science Foundation Division of Polar Programs presentation to the Synthesis Group. Arlington, VA: October 9, 1990.
- Rovang, R.D., J.D. Mills, and E. Baumeister. "Multimegawatt Potassium Rankine Power for Nuclear Electric Propulsion." Eighth Symposium on Space Nuclear Power Systems. Albuquerque, NM: January 1991.
- Ryder G., P.D. Spudis, and G.J. Taylor. "The Case for Planetary Sample Returns: Origin and Evolution of the Moon and its Environment," EOS, Transactions in American Geophysics Union, Vol. 70, No. 47, 1990.
- Schock, A. et al. "Mars Rover RTG Study." 40th Congress of the International Astronautical Federation. Paper No. IAF-89-270. Malaga, Spain: October 1989.
- Sherwood, B. (Boeing Aeronautics and Electronics). "Early Surface Habitation Elements for Planetary Exploration Missions," AIAA 90-3737. Presented at the Space Programs and Technology Conference. Huntsville, AL: September 25-28, 1990.

- Smith, R.E. and G.S. West. "Space and Planetary Environment Criteria Guidelines for Use in Space Vehicle Development." NASA, Marshall Space Flight Center. Technical Memorandum 82478, Rev. Vol 1. Huntsville, AL: 1982.
- Snyder, H.J., T.A. Sgammato, and M.J. Woodring. "STAR-C, A Thermionic Reactor for Low Power Space Applications." Twenty-second Intersociety Energy Conversion Engineering Conference. Philadelphia, PA: August 1987.
- Sovie, R.J. and J.M. Bozek. "Nuclear Power Systems for Lunar and Mars Exploration." NASA Technical Memorandum 103168, IAF-90-200. Washington, DC: October 1990.
- Spudis, P.D. and G.J. Taylor. "Rationale and Requirements for Lunar Exploration." *American Society of Civil Engineers Space '90 Proceedings*. Albuquerque, NM: 1990.
- Sullivan, Ralph. "Aerospace Power." *AIAA Aerospace America*. Washington, DC: December 1990.
- Sullivan, T.A. and D.S. McKay. *Using Space Resources*. NASA, Johnson Space Center, Office of Mission Science and Technology Report. Houston, TX: 1991.
- Taylor G.J. and P.D. Spudis, eds. "Geoscience and a Lunar Base: A Comprehensive Plan for Lunar Exploration." NASA, Johnson Space Center, Conference Publication 3070. Houston, TX: 1990.
- Taylor, G.J., and P.D. Spudis. "A Teleoperated Robotic Field Geologist." *American Society of Civil Engineers Space '90 Proceedings*. Albuquerque, NM: 1990.
- Taylor, S. R. *Planetary Science: A Lunar Perspective*. Houston, TX: Lunar Planetary Institute, 1982.
- Teren, Fred. "Space Station Electric Power System Requirements and Design." Twenty-second Intersociety Energy Conversion Engineering Conference. Philadelphia, PA: August 1987.
- United Technologies Corporation. "Technology and Mission Architecture Briefing." Presentation to the Synthesis Group. Arlington, VA: September 13, 1990.
- Verga, R., D. Buden, and M. Nikolich. "Five Years of SDIO Power Development Progress." Twenty-fifth Intersociety Energy Conversion Engineering Conference. Reno, NV: August 1990.
- Webbon, Bruce. Personal correspondence. November 13, 1990.
- Wilde, Richard C. "AIAA Assessment of Innovative Technologies for the Exploration of Space: Baseline Technology for Lunar/Mars EVA." United Technologies Corporation, Hamilton Standard Division. Washington, DC: September 5, 1990.
- Woodcock, G.R. "Basing Options for Lunar Oxygen for Manned Mars Missions," *American Society of Civil Engineers Space '88 Proceedings; Engineering, Construction, and Operations in Space*. New York, NY: 1988.
- Woodcock, G.R. "Economical Space Exploration System Architectures." *American Society of Civil Engineers Space '90 Proceedings; Space Construction and Operations*. Albuquerque, NM: 1990.
- Woodcock, Gordon (Boeing Study Manager). "Robotic Lunar Surface Operations." NASA 2-12108. Huntsville, AL: January 2, 1990.
- Zubrin, Baker, and Gwynne. "Mars Direct: A Simple, Robust, and Cost Effective Architecture for the Space Exploration Initiative." AIAA paper 91-0326. Twenty-fifth Aerospace Sciences Meeting. Orlando, FL: January 7-10, 1991.

Page	iv	<i>Thomas P. Stafford, Gemini/ Apollo Astronaut</i> by Paul Calle
	3	<i>Leaving Earth Orbit</i> by Robert McCall
	6	<i>Beyond the Moon</i> by William Hartman
	10	<i>Bringing in Big Boy</i> by Pamela Lee
	27	<i>American Exploration</i> by Robert McCall
	29	<i>Martian Surface</i> by Michael Carroll
	35	<i>Astronauts Collecting Martian Samples</i> by Robert McCall
	39	<i>On the Rim</i> by Alan Bean
	41	<i>Martian Science and Exploration Facilities</i> by Robert McCall
	43	<i>Radio Telescope Emplaced in Lunar Crater</i> by Pat Rawlings
	44	<i>Reconnaissance of Near Earth Asteroid</i> by William Hartman
	45	<i>Mars Robotic Explorer Vehicle</i> by John Frassanito
	47	<i>Lunar Base</i> by Robert McCall
	52	<i>Lunar Resource Mining</i> by Robert McCall
	57	<i>Exploring the Moon</i> by Pierre Mion
	72	<i>Armstrong's Suit-up, Apollo XI</i> by Paul Calle
	79	<i>Lunar Excursion Vehicle</i> by Pat Rawlings
	82	<i>Madrid Deep Space Communications Complex</i> by Alan Chinchar
	87	<i>Back to the Future</i> by John Pike
	89	<i>A Journey Into Tomorrow</i> by David Hardy
	92	<i>Zero Gravity Training</i> by Nathan Greene
	111	<i>Mission Preparation</i> by Henry Casselli

*Back to Stay*



Inside back cover art courtesy of Robert J. McCall © 1991



"Space Exploration is the ultimate investment in America's Future."

George W. Bush

*McCall
91*

The Synthesis Group Reports are available from the
Superintendent of Documents, U.S. Government Printing Office, Washington D.C. 20402

Artwork/photographs in this report which are not furnished by a federal agency are protected by a copyright and are reproduced herein with the permission of the copyright owner. No right to reproduce or use the artwork/photographs without the express permission of the copyright owner shall be implied from their inclusion herein.