

The NASA "Why?" Files  
The Case of the  
Challenging Flight

Program 4 in the 2000-2001 Series

Educator's Guide	
Teachers & Students	Grades 3-5

EP-2001-02-15-LaRC





Educator's Guide	
Teachers & Students	Grades 3-5

EP-2000-09-20-LaRC

For additional information about the NASA "Why?" Files, contact Shannon Ricles at (757) 864-5044 or e-mail at [s.s.ricles@larc.nasa.gov](mailto:s.s.ricles@larc.nasa.gov)

Production of the NASA "Why?" Files is made possible by the generous support provided by AIAA Foundation; Busch Gardens, Williamsburg; Hampton City Public Schools; and the NASA Langley Research Center's Learning Technology Project and Aerospace Vehicle Systems Technology Program Office.

**Writers and Teacher Advisors:**

Shannon Ricles, Dan Locke,  
John Livingston

**Editors:**

Bill Williams and Susan Hurd

The American Institute of Aeronautics and Astronautics (AIAA) provides classroom mentors to educators who register for the NASA "Why?" Files. Every effort will be made to match a teacher with an AIAA member who will mentor the teacher either in person or by e-mail. To request a mentor, e-mail [nasawhyfiles@aiaa.org](mailto:nasawhyfiles@aiaa.org)



Contact the AIAA to get a classroom mentor at [nasawhyfiles@aiaa.org](mailto:nasawhyfiles@aiaa.org).

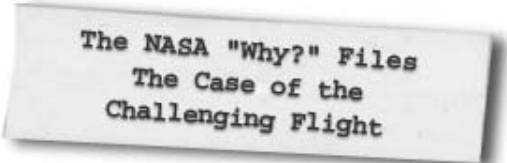

# Index

---

	Program Overview . . . . .	4
	National Geography Standards . . . . .	4
	National Math Standards . . . . .	5
	National Science Standards . . . . .	6
	National Educational Technology Standards . . . . .	7
<b>Part 1</b>	<b>Segment 1</b>	
	Segment Overview . . . . .	9
	Objectives . . . . .	10
	Vocabulary . . . . .	10
	Video Component . . . . .	10
	Careers . . . . .	11
	Resources . . . . .	12
	Activities and Worksheets . . . . .	13
<b>Part 2</b>	<b>Segment 2</b>	
	Segment Overview . . . . .	23
	Objectives . . . . .	24
	Vocabulary . . . . .	24
	Video Component . . . . .	25
	Careers . . . . .	25
	Resources . . . . .	26
	Activities and Worksheets . . . . .	27
<b>Part 3</b>	<b>Segment 3</b>	
	Segment Overview . . . . .	37
	Objectives . . . . .	38
	Vocabulary . . . . .	38
	Video Component . . . . .	38
	Careers . . . . .	39
	Resources . . . . .	39
	Activities and Worksheets . . . . .	40
<b>Part 4</b>	<b>Segment 4</b>	
	Segment Overview . . . . .	53
	Objectives . . . . .	54
	Vocabulary . . . . .	54
	Video Component . . . . .	54
	Careers . . . . .	55
	Resources . . . . .	55
	Activities and Worksheets . . . . .	56

## Program Overview

In *The Case of the Challenging Flight*, the tree house detectives are onto a new case as they try to win the Egg-tra-ordinary Plane Contest. They do not want to repeat their unsuccessful performance of years past; therefore, they decide that they need to build a better plane. The tree house detectives use their skills in scientific investigation to learn about the four forces of flight and then use their newfound knowledge as they design and construct a plane.

As the tree house detectives actively pursue this challenge, they learn of other competitions in flight throughout history. They meet with General John (Jack) R. Dailey, director of the National Air and Space Museum in Washington, D.C. to learn more about the Wright Brothers, Charles Lindbergh, the race for space, and other contests of the past.

As the tree house detectives endeavor to learn more about the four forces of flight: lift, thrust, drag, and weight, Dr. D, a retired science professor, guides them to seek help from NASA researchers. The tree house detectives receive a surprise visit from Jackie Chan, the human flying machine, who offers advice on how to attack a problem and the value of education. They are also invited as guests of the U.S. Navy to visit an aircraft carrier, the *USS Theodore Roosevelt*. They have a once-in-a-lifetime experience as they land and are catapulted off the flight deck of one of the world's largest carriers.

*The Case of the Challenging Flight* is one of the tree house detectives' most challenging cases and promises not to be a "drag." Even though the rival schools are good, the tree house detectives are determined to "foil" their winning streak and become the new champions of the Egg-tra-ordinary Plane Contest. Tune in to see the how the tree house detectives "pitch, yaw, and roll" and to learn who the winner will be!



## National Geography Standards (grades 3-5)

Standard	Segment			
	1	2	3	4
<b>The geographically informed person knows and understands:</b>				
<b>The World in Spatial Terms</b>				
How to use maps and other graphic representations, tools, and technologies to acquire, process, and report information from a spatial perspective		x		

## National Math Standards (grades 3–5)

Standard	Segment			
	1	2	3	4
<b>Numbers and Operations</b>				
Understand numbers, ways of representing numbers, relationships among numbers, and number systems.		x		
<b>Algebra</b>				
Understand patterns, relations, and functions.			x	
<b>Measurement</b>				
Understand measurable attributes of objects and the units, systems, and processes of measurement.	x	x		
Apply appropriate techniques, tools, and formulas to determine measurements.	x	x		x
<b>Data Analysis and Probability</b>				
Formulate questions that can be addressed with data and collect, organize, and display relevant data to answer them.	x	x	x	
Select and use appropriate statistical methods to analyze data.	x	x	x	
Develop and evaluate inferences and predictions that are based on data.	x	x	x	
<b>Problem Solving</b>				
Build new mathematical knowledge through problem solving.		x		
Solve problems that arise in mathematics and in other contexts.	x		x	x
Apply and adapt a variety of appropriate strategies to solve problems.	x	x	x	x
Monitor and reflect on the process of mathematical problem solving.			x	x
<b>Connections</b>				
Recognize and apply mathematics in contexts outside of mathematics.	x	x	x	x
<b>Representation</b>				
Select, apply, and translate among mathematical representations to solve problems.		x		
Use representations to model and interpret physical, social, and mathematical phenomena.	x	x	x	x

## National Science Standards (grades k–4)

Standard	Segment			
	1	2	3	4
<b>Concepts and Processes</b>				
Systems, orders, and organization	x	x	x	x
Evidence, models, and explanations	x	x	x	x
Change, constancy, and measurement		x	x	
Evolution and Equilibrium	x		x	
Form and Function	x	x	x	x
<b>Science and Inquiry (A)</b>				
Abilities necessary to do scientific inquiry	x	x	x	x
Understanding about scientific inquiry	x	x	x	x
<b>Physical Science (B)</b>				
Properties of objects and materials			x	x
Position and motion of objects	x	x	x	x
<b>Life Science (C)</b>				
Characteristics of Organisms			x	
<b>Science and Technology (E)</b>				
Abilities of technological design		x	x	x
Understanding about science and technology	x	x	x	x
Abilities to distinguish between natural objects and objects made by humans			x	
<b>Science in Personal and Social Perspective (F)</b>				
Science and technology in local challenges	x	x	x	x
<b>History and Nature of Science (G)</b>				
Science as a human endeavor	x	x	x	x

## National Science Standards (grades 5–8)

Standard	Segment			
	1	2	3	4
<b>Concepts and Processes</b>				
Systems, order, and organization	x	x	x	x
Evidence, models, and explanations	x	x	x	x
Change, constancy, and measurement		x	x	
Evolution and equilibrium	x		x	
Form and function	x	x	x	x
<b>Science as Inquiry (A)</b>				
Abilities necessary to do scientific inquiry	x	x	x	x
Understandings about scientific inquiry	x	x	x	x
<b>Physical Science (B)</b>				
Motion and forces	x	x	x	x
Transfer of energy		x		
<b>Life Science (C)</b>				
Structure and function in living systems			x	
Regulation and behavior			x	
Diversity and adaptations of organisms			x	
<b>Science and Technology (E)</b>				
Abilities of technological design	x	x	x	
Understanding about science and technology	x	x	x	x
<b>Science in Personal and Social Perspectives (F)</b>				
Science and technology in society	x	x	x	x
<b>History and Nature of Science (G)</b>				
Science as a human endeavor	x	x	x	x
Nature of science	x		x	
History of science	x			

## National Educational Technology Standards (grades 3–5)

Performance Indicators for Technology-Literate Students

Standard	Segment			
	1	2	3	4
<b>Basic Operations and Concepts</b>				
Discuss common uses of technology in daily life and the advantages and disadvantages those uses provide.	*			*
<b>Social, Ethical, and Human Issues</b>				
Discuss common uses of technology in daily life and the advantages and disadvantages those uses provide.				*
<b>Technology Productivity Tools</b>				
Use general purpose productivity tools and peripherals to support personal productivity, remediate skills deficits, and facilitate learning throughout the curriculum.		*	*	
<b>Technology Communication Tools</b>				
Use technology tools for individual and collaborative writing, communication, and publishing activities to create knowledge products for audiences inside and outside the classroom.	*		*	
Use telecommunication efficiently and effectively to access remote information, communicate with others in support of direct and independent learning, and pursue personal interests.			*	
Use telecommunication and on-line resources to participate in collaborative problem-solving activities for the purpose of developing solutions or products for audiences inside and outside the classroom.	*	*	*	
<b>Technology Research Tools</b>				
Use telecommunication and on-line resources to participate in collaborative problem-solving activities for the purpose of developing solutions or products for audiences inside and outside the classroom.	*	*	*	
Use technology resources for problem solving, self-directed learning, and extended learning activities.	*	*	*	
<b>Technology Problem-Solving and Decision-Making Tools</b>				
Use technology resources for problem solving, self-directed learning, and extended learning activities.	*	*	*	
Determine when technology is useful and select the appropriate tools and technology resources to address a variety of tasks and problems.	*			





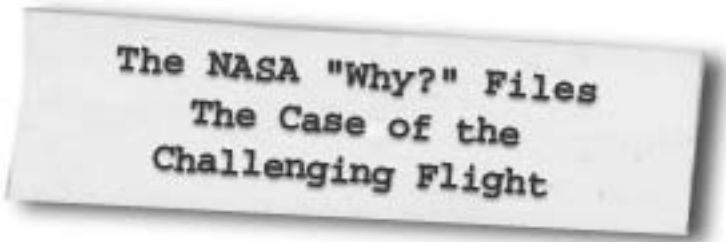

The NASA "Why?" Files  
The Case of the  
Challenging Flight

# Segment 1

The tree house detectives are determined to win the Egg-traordinary Plane Contest. They start by studying the history of flight and learn how other contests have helped to advance aviation. A visit with General John (Jack) R. Dailey at the National Air and Space Museum in Washington, D.C. gives them much needed information about the Wright Brothers, Charles Lindbergh, and the race to space. The tree house detectives also visit the "How Things Fly" exhibit and are introduced to the four forces of flight: lift, thrust, drag, and weight.

When the tree house detectives visit Dr. D's lab, he directs them to Luther Jenkins and a NASA wind tunnel to learn more about lift. The tree house detectives also get some help from the NASA "Why?" Files Kids Club at Achievable Dreams School in Newport News, VA. A class is performing an experiment to determine how the size of a wing affects lift. The tree house detectives visit the school to test their new hypothesis and receive a surprise visit from Jackie Chan, the human flying machine!

## Objectives

---

The students will

- learn the significance of the Wright Brothers' historic flight on December 17, 1903.
- learn how competitions such as the Orteig Prize won by Charles Lindbergh have accelerated advancement in flight.
- learn how the U.S. and Russia were in a "race for space" to be the first to put a man on the Moon.
- learn the four forces of flight: lift, thrust, drag, and weight.
- learn how lift is created.
- learn how the "angle of the wing" affects lift.
- discover that the size of the wing affects lift.

## Vocabulary

---

**aeronautics** - word derived from the Greek word for "air" and "to sail." It is the study of flight and the operation of aircraft.

**airfoil** - section of a wing, rudder, aileron, or rotor blade used for testing the reaction from air through which it moves

**airplane** - a heavier than air winged vehicle that is capable of flight and is propelled by jet engines or propellers

**aviation** - the operation of aircraft

**curvature** - a curving or bending

**drag** - the air resistance acting on airplanes. Drag acts in the opposite direction to thrust.

**force** - a push or pull used to lift something, start it moving, or hold it in place against another force, such as gravity

**fuselage** - the main structural body of an aircraft to which the wings and tail unit are attached

**gravity** - the force of attraction that makes objects fall toward the Earth

**lift** - a force that acts upward against gravity and makes it possible for airplanes, airships, and balloons to rise in the air

**surface area** - the sum of the areas of all the faces of a three-dimensional figure

**third law of motion** - Sir Isaac Newton's law of motion that states that for every action there is an equal and opposite reaction

**thrust** - a forward force that pushes an airplane through the air

**weight** - a response of mass to the pull of gravity

**wind tunnel** - a chamber where air or smoke is blown over an object such as an airfoil to calculate its aerodynamic forces, such as lift and drag

## Video Component (15 min)

---

### Before Viewing

1. Introduce the video by reading its title and synopsis. Ask students if they have ever made an airplane. Have them describe the



types of planes they created and the problems with each. Make a chart of the types made and list the problems that students encountered. For example, model airplanes: pieces too small, glue didn't stick, didn't understand the directions, wouldn't fly, and so on.

2. To assess students' background knowledge on flight, choose one or more of the following:
  - Have students define key vocabulary terms such as flight, lift, drag, weight, thrust, wing, fuselage, and rudder.
  - Have students write and illustrate a story of their favorite airplane flight.
  - Have students illustrate how a plane flies.
  - Discuss how a plane flies.
3. Introduce or review scientific inquiry and the scientific method. For additional information and worksheets on scientific inquiry and the scientific method, visit the NASA "Why?" Files web site at <http://whyfile.larc.nasa.gov>
4. Ask students to predict what the tree house detectives will need to do to learn more about flight and where they need to begin their investigation. Create a K-W-L chart (What you **know**, What you **want** to know, and What you have **learned**) for various predictions. You may download a copy of a K-W-L chart from the NASA "Why?" Files web site.

What do we <b>know</b> ?	What do we <b>want</b> to find out?	What have we <b>learned</b> ?

### After Viewing

1. Discuss the questions at the end of the first video segment.
  - What size should the tree house detectives plan for their plane's wings?
  - What should they do next?
  - How can they get more lift?
2. The tree house detectives begin their investigation of the four forces of flight: lift, thrust, drag, and weight. Divide up the class in small groups and ask each group to demonstrate one of the forces after a short research and preparation time. The demonstration may take the form of a short skit, puppet show, or mime.
3. The experiment shown in this video segment studies the relationship between the size of wings and flight. Review with the students the results of the experiment and how they might affect the construction of their own plane.
4. Make a display board showing the parts of a scientific investigation. Include the following words: problem statement, research, materials, hypothesis, procedure, data, conclusion, variables, information, experiments, questions. Some of these words may be used several times during an investigation. As a class, ask the students to write down the steps that the tree house detectives use to solve the problem during the four video segments.
5. Have students find out about prizes and the history of flight. Some examples are the Orteig Prize and Charles Lindbergh's Atlantic crossing, the Vin Fiz cross-country flight and the Hearst Prize, and the ten million dollar X-Prize for the international race to develop a commercial space plane. Sample web sites for information include <http://www.xprize.org/>, <http://aerofiles.com/vinfiz.html>, <http://www.centennialofflight.gov/>,

### Careers

actor  
 museum director  
 astronaut  
 teacher  
 inventor

[http://www.flight100.org/history\\_intro.html](http://www.flight100.org/history_intro.html)

6. If the students defined key vocabulary terms prior to viewing the video, ask if they would like to change any definitions and why. Select activities in this lesson guide or on the NASA "Why?" Files web site to help reinforce the concepts and objectives emphasized in this segment.
7. Continue to add to the K-W-L chart. Discuss the process of scientific inquiry. Ask students to predict what the tree house detectives will do next in their quest to learn more about flight. Add predictions to the K-W-L chart.
8. Choose from the activities in this guide or on the web site at <http://why-files.larc.nasa.gov> to help reinforce the concepts and objectives being emphasized in segment 2.

## Resources

---

### Books

- Boyne, Walter J.: *The Smithsonian Book of Flight for Young People*. Macmillan Publishing Company (1988), ISBN 068971212
- Chaikin, Andrew: *Air and Space: The National Air and Space Museum Story of Flight*. Bulfinch Press (2000), ISBN: 0821226703
- Demerest, Chris L: *Lindbergh*. Crown Books for Young Readers (1993), ISBN: 0517587181
- Hart, Philip S.: *Flying Free: America's First Black Aviators*. Lerner Publications, Co. (1992), ISBN: 0822515989
- Krensky, Stephen: *Taking Flight: The Story of the Wright Brothers*. Simon and Schuster Children's Pub. (2000), ISBN: 0689812258
- Scott, Phil (Editor): *The Pioneers of Flight: A Documentary History*. Princeton University Press (1999), ISBN: 0691011176
- Sobol, Donald J.: *The Wright Brothers at Kitty Hawk*. Scholastic, Inc. (1986) ISBN: 0590429043
- Shea, George: *First Flight: The Story of Tom Tate and the Wright Brothers (I Can Read Chapter Book Series)*. HarperCollins Children's Books (1997), ISBN: 0064442152

### Activity Books

- Wilbur and Orville Wright*—An activity book packed full of facts, games, and puzzles. A single copy of this publication may be ordered on school letterhead from: Nat'l HQ CAP/ETD, Maxwell AFB, AL 36112-6332.
- Charles A. Lindbergh*—An activity book packed full of facts, games, and puzzles. A single copy of this publication may be ordered on school letterhead from: HQ CAP/EDE, Maxwell AFB, AL 36112-5572.

### Web Sites

#### NASA "Why?" Files

<http://whyfiles.larc.nasa.gov/>

#### Aerospace Team On-line

Features the Wright Flyer. Students can learn about the Wright Flyer Project, meet the people involved in the project, go back in time to the early days of aviation, and talk about science. Include some additional resources/activities. <http://quest.arc.nasa.gov/aero/wright/>

#### The U.S. Centennial of Flight Commission

Features the history of aviation and shares the future of flight. A calendar of

events links to air show listings throughout the U.S.  
<http://centennialofflight.gov/>

**The Beginner’s Guide to Aerodynamics**

Includes the study of forces and the resulting motion of objects through the air. The guide allows you to move at your own pace and depth of study. Graphics throughout the site make it easy to understand the principles of flight.

<http://www.grc.nasa.gov/WWW/K-12/airplane/bga.html>

**WayBack - U.S. History for Kids**

Cool facts about important pilots, inventors, other aviation pioneers, a modern-day aerial stunt artist, and more.

<http://www.pbs.org/wgbh/amex/kids/flight/>

Do you ever wonder how things fly? An interactive and colorful site with information on the properties of air, the four forces of flight, and more.

<http://www.aero.hq.nasa.gov/edu/>

**National Air and Space Museum**

Click on “Exhibitions” and explore the “How Things Fly” exhibit or discover the milestones of flight. Learn about space exploration, rocketry, and much more.

<http://www.nasm.edu/>

**Aeronautical Terms**

Learn how to use sign language for aeronautical terms, learn the principles of aeronautics (various reading levels), explore possible careers, or check out experiments for flight. For teachers, there are lesson plans and curriculum bridges.

<http://wings.ucdavis.edu/>

**Activities and Worksheets**

**In the Guide**

**A Time to Remember . . . . .14**  
 A timeline of historic aviation pioneers and aircraft.

**Wright 1903 Flyer . . . . .15**  
 Construct a model of the Wright Flyer.

**Lucky Lindy and the Spirit of St. Louis . . .16**  
 Trace the flight path that won Charles Lindbergh the Orteig Prize.

**Lift Experiment . . . . .17**  
 Discover if the size of a wing affects lift.

**Bernoulli’s Principle . . . . .19**  
 Create a paper bag mask to understand the effect that air has over a curved surface.

**Thar She Blows . . . . .20**  
 Demonstrate a wind tunnel and experiment with various shapes.

**Airfoils . . . . .21**  
 Learn how an airfoil creates lift.

**Answer Key . . . . .22**

**On the Web**

You can find the following activities on the Web at <http://whyfiles.larc.nasa.gov>.

**Aviation Pioneers**

Activity to learn more about the historic flight of the Wright Brothers.

**Flight Museum**

Design your own classroom flight museum.

**Newton’s In the Driver’s Seat**

Learn about Newton’s Third Law of Motion.



# A Time to Remember

## Purpose

To create a timeline of historic aviation pioneers and aircraft.

## Procedure

1. In advance of the activity, the teacher may wish to prepare the timeline or he/she may elect to have the students create it. See steps 6-8 for advance preparation.
2. Divide class into groups of 3-4 students.
3. Assign or let students choose 4-5 aviation pioneers and 2-3 famous aircraft.
4. Students begin their timeline by researching the significance and date of importance for each pioneer and aircraft they have chosen.
5. Using a white square of paper for each pioneer or aircraft, students should draw a picture depicting the pioneer or aircraft, color, and label it with the name and date.
6. To create the timeline, measure and cut 6 m of adding machine tape. If adding machine tape is not being used, measure and cut strips of paper 5 cm wide and glue together for a length of 6 m.
7. Use a marker and draw a vertical line every 25 cm.
8. Label one end of the timeline 1500 AD and continue labeling each line drawn in 25-year increments. The opposite end of the tape ends with the year 2100.
9. Have students present their aviation pioneers and aircraft and place them appropriately on the timeline.
10. Have the students brainstorm and discuss ideas for the future of aviation.
11. Have members of each group choose an idea and draw a square to represent their idea of the future of aviation. This idea could be a futuristic plane or who they think will be a great future aviator, it may even be one of them!
12. Display the timeline in the hall or other centralized area of the class or school.

## Materials

- roll of adding machine tape or strips of paper
- white paper cut into 10-cm X 10-cm squares (enough for each pioneer and each aircraft on timeline)
- list of aviator names and aircraft
- crayons or markers
- scissors
- glue

## Conclusion

1. Which pioneer do you think is the most important person in the history of aviation and why?
2. Which aircraft do you think is the most important aircraft in the history of aviation and why?

## Extensions

1. Have the students create individual timelines.
2. Have the students choose an aviation pioneer and research him/her in-depth to present to the class. Have the students dress in character for presentation.
3. Write at least five "Who Am I?" riddles about famous aviators or aircraft and try them on a friend.

### Aviation Pioneers

Leonardo da Vinci	James H. Doolittle
Amelia Earhart	Otto Lilienthal
Charles Lindbergh	Oakley Kelly
Etienne and Joseph Montgolfier	Wiley Post
Marquis d'Arlandes	Calbraith O. Rodgers
Wilbur and Orville Wright	Anthony H. G. Fokker
Samuel P. Langley	Daedalus
Sir George Cayley	Glenn Curtiss
Clyde Cessna	William Piper
Neil Armstrong	Donald Douglas
Charles "Chuck" Yeager	Jean F. Pilatre
Bessie Coleman	John Glenn

### Aircraft

X-15	<i>Gossamer Condor</i>
Douglas DC-3	Ford Tri-Motor
Cessna 150	Piper Cub
<i>Winnie Mae</i>	<i>EX Vin Fiz</i>
<i>Chicago</i>	Northrop Alpha
AEA Hydro Aircraft	<i>Daedalus</i>
Learjet	X-1
<i>Wright Flyer</i>	<i>Spirit of St. Louis</i>
Mitsubishi Zero-Fighter	F-14
F-18	Saturn 5 Rocket
Space Shuttle	

# Wright 1903 Flyer

## Purpose

To construct a model of the Wright Flyer.

## Procedure

1. Trace pattern pieces of the Wright Flyer onto rigid plastic foam.
2. Using a pin, mark all holes in the diagram by pushing the pin through the paper and into the plastic foam.
3. Using a marker, mark dotted lines as shown.
4. Using scissors, cut out all pattern pieces.
5. Shape the wings and rudder by cutting on the dotted lines.
6. Push one toothpick lengthwise through the center of each rudder. Glue each rudder upright at one end of the body with one on each side. Then glue onto the top of the rudder. See diagram.
7. Dip 18 toothpicks in glue and place the toothpicks upright on the dot marks made by the pin. Dab glue on the toothpick tops and lay the second wing carefully on them, using the dots as a guide.
8. Press together carefully.
9. To create the propellers, cut a toothpick in half and glue one piece to each of the two middle toothpicks.
10. Set the plane aside to dry.
11. Cut three toothpicks in half and dip the end of five halves into glue.
12. Place the toothpicks upright on the dots on one section of the elevator. Dab glue on the tops and place the second section of the elevator on them.
13. Press together carefully and set aside to dry.
14. Once the glue has dried, glue the set of wings to the center of the body.
15. Glue the set of elevators to the other end of the body.
16. Tape a dime or penny to the bottom of the Flyer between the wings and the elevators.
17. Set aside to dry.
18. Once the glue is dry, you are ready to fly your plane.

## Materials

plastic foam  
scissors  
18 toothpicks  
per plane  
glue  
marker or pen  
pin  
pattern

## Conclusion

1. How did the Wright Flyer differ from airplanes of today?

## Extensions

1. Create models of airplanes of the past and present or imaginary ones of the future from various recyclable materials such as juice or soda cans, cardboard, paper tubes, plastic bottles, or paper cups, and so on.

## Flyer Diagram

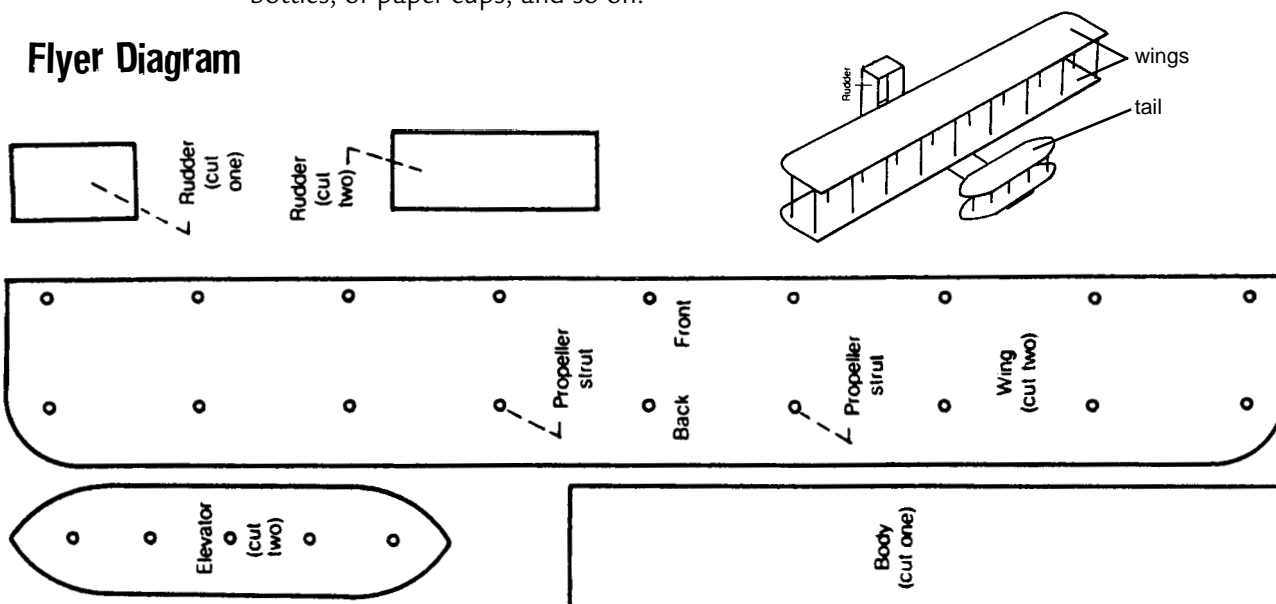

# Lucky Lindy and the Spirit of St. Louis

Research Charles Lindbergh to discover the flight path he flew in 1927 in his famous 33 1/2-hour flight across the Atlantic Ocean. On the map below, draw the path. Write a description of what the flight might have been like for Charles Lindbergh. Be sure to include the prize that he won for his accomplishment!



---

---

---

---

---

---

---

---

---

---

---

---





# Lift Experiment

## Purpose

To determine if the size of a wing affects lift.

## Procedure

1. To make the test setup, anchor one end of the hinge to the side of a desk with masking tape. (For a more permanent setup, use a wooden box and screws to anchor the hinge to the wooden box.)

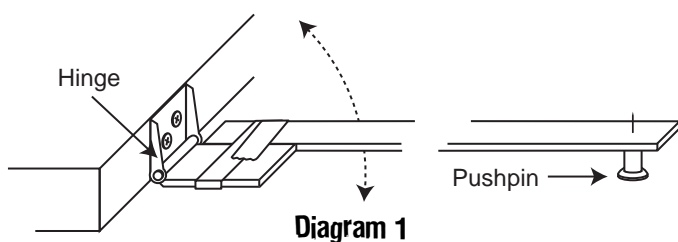

2. Tape the fuselage stick to the end of the hinge. Stick should pivot freely up and down. See diagram 1.
3. On the end of the stick that is not attached to the hinge, push the pushpin through the wood so that you have a point on top of the stick.
4. To replace the weight of the propeller, tape two pennies to the front of the egg crate plane on either side of the fuselage. See diagram 2.

5. To attach a test wing, you must first find the balance point. Place the wing in a centered position on the fuselage, then place your finger under the wing. If the wing is positioned correctly, it should balance. If not, adjust the position forward or back until a balance is achieved. Adjust the tilt of the wing so that it is tilted approximately 15 degrees to give it a positive incidence (upward tilt).

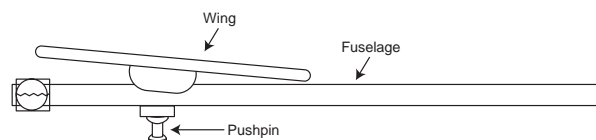

6. Attach test wing 1, find balance, add the tilt, and tape it into place.
7. Place the egg crate plane with test wing onto the pushpin. The plane should be positioned on the pushpin with the pin directly under the wing. See diagram 2. Rest the plane on a desk.

8. Position the fan on a desk or stool so that it is in front of the test setup with the plane in front of the middle of the fan.
9. Turn the fan on low and tighten any loose tape.
10. Increase the fan speed until the plane lifts off the desk.
11. Once the plane is stable, begin adding pennies to the pylon cavity in the center of the wing until the plane will no longer fly. See diagram 3.

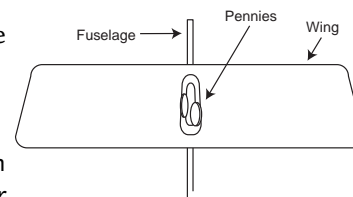

12. Calculate the amount of weight/mass added to the plane.  
You can use a balance to find the weight/mass of the pennies, or you can multiply the number of pennies by 2.5 grams (average weight/mass of a penny). Record weight/mass in chart.
13. Repeat for two more trials and find the average number of pennies and weight/mass lifted.
14. Repeat with test wing 2 and test wing 3.
15. Compare results among groups and discuss.

## Materials (per group)

completed egg crate plane, less main wing and propeller/rubber band (see page 68-69)  
two pennies  
box fan  
62 cm length of balsa wood for fuselage stick  
hinge (you may be able to substitute heavy tape for the hinge)  
tape, masking and cellophane  
two dozen pennies for measurement purposes  
pushpin  
one 20 cm X 6 cm wing (test wing #1)  
one 28 cm X 6 cm wing (test wing #2)  
one 28 cm X 12 cm wing (test wing #3)

## Lift Experiment (continued)

Test Wing	Number of Pennies Lifted	Weight/Mass of Pennies
Test Wing 1 Trial 1		
Test Wing 1 Trial 2		
Test Wing 1 Trial 3		
<b>Average of Test Wing #1</b>		
Test Wing 2 Trial 1		
Test Wing 2 Trial 2		
Test Wing 2 Trial 3		
<b>Average of Test Wing #2</b>		
Test Wing 3 Trial 1		
Test Wing 3 Trial 2		
Test Wing 3 Trial 3		
<b>Average of Test Wing #3</b>		

**Conclusion** 1. Which wing held the most pennies and why?

2. Why was it important to perform more than one trial?

3. Why did you average the number of pennies and weight?

4. Design a wing that would lift more weight.

**Extensions**

1. Find a class average for the number of pennies lifted and the weight of the pennies.
2. Test other sizes of wings.
3. Test other shapes of wings.

# Bernoulli's Principle

## Purpose

To understand the effect of air flowing over a curved surface. To understand Bernoulli's principle.

## Procedure

1. Working in pairs, have one student place a bag over his/her head and have the second student carefully draw small dots where the eyes, nose, and mouth are located.
2. Remove the bag from the head and draw a face around the markings and color mask.
3. Cut out two holes (approximately 2 cm in diameter) for the eyes.
4. Cut a hole (approximately 4 cm in diameter) for the mouth.
5. To make the tongue, cut a strip of paper, approximately 3 cm wide and 20 cm long.
6. Tape or glue one end of the tongue inside the bag at the bottom of the mask's mouth. Allow the tongue to droop through the mouth on the outside of the bag.
7. Place the bag over the head and blow through the mouth hole. Observe the movement of the tongue.
8. Discuss and explain Bernoulli's principle.

## Materials

large paper grocery bags  
scissors  
crayons or markers  
notebook paper  
tape or glue  
metric ruler

## Conclusion

1. Why does the tongue move when you blow gently through the mouth?
2. What happens when you blow harder?
3. Draw a diagram of the flow of air over the strip of paper.
4. Explain how Bernoulli's principle applies to the lift of a wing on a plane.
5. List some common examples that demonstrate Bernoulli's principle.

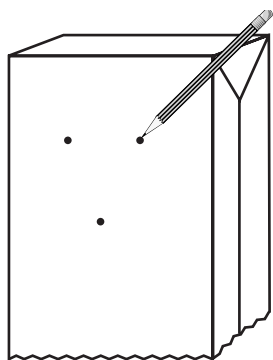

Step 1

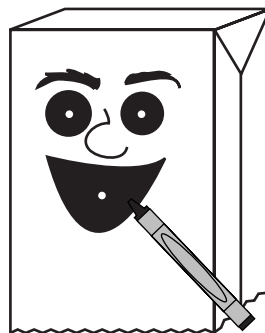

Step 2

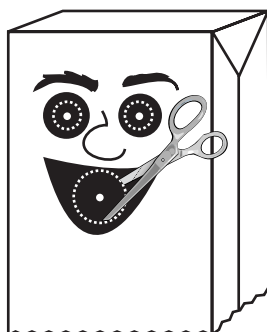

Step 3 and 4

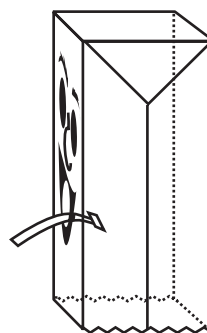

Step 6

# Thar She Blows

**Purpose** To demonstrate a wind tunnel.

- Procedure**
1. To create the wind tunnel out of heavyweight paper, cut the paper approximately 1.5 m by 30 cm and roll into a tube shape. Roll the paper so that the smaller dimension creates the circle. Overlap ends and tape into place. See diagram 1.
  2. Create various shaped airplanes or geometric shapes for testing, and using tape, attach a string to each.
  3. Have one student place the wind tunnel in front of a fan or blow-dryer.
  4. Place one of the test objects in front of the wind tunnel and turn on the fan or blow-dryer (see diagram 2).
  5. Observe motion of test object and record.
  6. Continue testing objects and record observations of each object in science journal.

- Conclusion**
1. What happened when the test objects were placed in the wind tunnel?
  2. Which objects had “lift”?
  3. Explain why some objects “lifted” better than others.
  4. Other than testing a plane, what uses are there for wind tunnels?

## Materials

- large paper tube or heavyweight paper
- fan or blow-dryer
- tape
- 30 cm of string for each model
- plastic foam to make various models of airplanes or geometric shapes (These may be created by the teacher prior to experiment.)

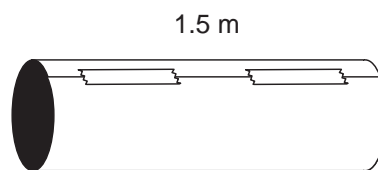

Diagram 1

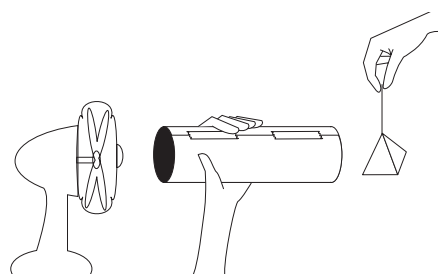

Diagram 2

Object	Observation

# Airfoils

## Purpose

To demonstrate how an airfoil creates lift. To understand Bernoulli's principle.

## Procedure

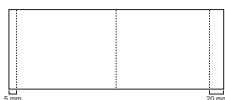

Diagram 1

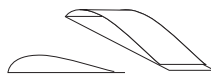

Diagram 2

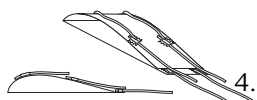
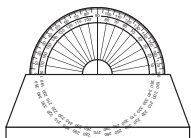

Diagram 3



Front view



Side view

Diagram 4

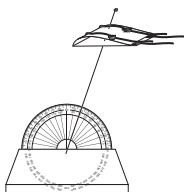

Diagram 5

1. Lay cardboard flat and measure 15 mm from one end of the cardboard and draw a line and measure 24 mm from the other end of the cardboard and draw a line. See diagram 1.

2. Fold the cardboard in half and fold the 15-mm edge of the cardboard so that it fits flat against the 24-mm edge. You should have a shape with a curved top (see diagram 2). This is an airfoil.

3. Lay the airfoil on its flat surface and make two holes through the center of the airfoil's widest part, one directly above the other. You may need adult help with this part.

4. Using tape, attach yarn to the airfoil as shown. See diagram 3.

5. Place the bead on one end of the stiff wire and loop or bend the wire so that the bead is secured to the end of the wire.

6. Guide the wire through the holes in the airfoil so that the curved side is on top and the flat side is on the bottom

7. Using a nail and hammer or drill, make a hole in the middle of the wooden block just big enough to hold the end of the wire.

8. Attach the protractor to the wooden block with either tape or glue. See diagram 4.

9. At a 70 degree angle, push the wire into the block so that it stands firmly (but not too firmly) so that the angle can be changed. See diagram 5.

10. On a flat surface, place the stand with the airfoil in front of the fan, making sure that the rounded edge of the airfoil is facing the fan. This edge is called the leading edge of the airfoil. The opposite edge is called the trailing edge. See diagram 6.

11. Turn the fan on low speed and observe. Record observations in science journal.

12. Adjust wire to decrease angle to a 40-degree angle and repeat step 12.

13. Take the wire out of the wooden block and flip the airfoil over so that the flat side is on the top and the curved side is on the bottom. See diagram 7.

14. Repeat Steps 10-13 and record observations.

## Materials

- protractor
- desk fan
- wooden block (length of protractor)
- 50 cm stiff wire
- bead
- scissors
- glue
- tape
- six 10-cm pieces of yarn
- thin cardboard 11 cm X 31 cm
- small nail
- hammer
- drill (optional)
- science journal

## Conclusion

1. What happened to the airfoil at a 70-degree angle?
2. What happened to the airfoil at a 40-degree angle?
3. Explain why there was a difference.
4. What happened when you flipped the airfoil over? Explain.
5. What conclusions can you draw from this experiment about the angle of a wing?

## Extensions

1. Experiment with various other angles.
2. Create other test objects to place on wire.

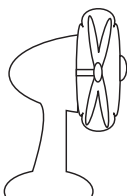

Diagram 6

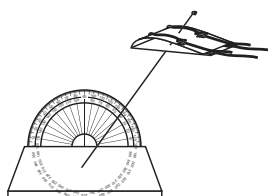

Diagram 7

## Answer Key

---

### Lift Experiment

1. The largest wing (28 cm X 12 cm) held the most pennies because it had a larger surface area that created more lift.
2. It is important to perform more than one trial to get accurate data. A scientist never relies on the data from just one trial because it might have been a faulty experiment or other factors may have skewed the data.
3. It was important to average the number of pennies and weight to a more accurate number. Each trial may have had slight variances, and by averaging the data, you come closer to an accurate answer.
4. Designs will vary.

### Bernoulli's Principle

1. The tongue moves when you blow gently through your mouth because the air molecules are attracted to and attach to the surface. The fast-moving air travels along the paper's surface. Lift occurs because the pressure on the upper surface of an object is less than the pressure on the lower surface.
2. When you blow harder, the tongue will move up and down faster.
3. Diagrams will vary.
4. Bernoulli's principle applies to the lift of a wing on a plane the same as it does to the paper. Air molecules flow over the curved surface of a wing, creating less pressure on the upper surface than on the lower surface, allowing the wing to lift.
5. Other examples are flags waving, sails, and an umbrella that becomes impossible to hold in a strong wind.

### Newton's In the Driver's Seat

1. When the cars made contact, they hit and then bounced away from each other.
2. As you pushed the cars, you exerted a force on each. When they hit, the cars pushed against each other and traveled away from the point of contact. Newton's Third Law of Motion states that for every action there is an equal and opposite reaction. The action was when the cars hit, and the reaction was when they moved away from each other.
3. If you applied a greater force on the cars, they would travel a greater distance away from each other.

### Thar She Blows

1. Answers will vary depending on objects.
2. Answers will vary depending on objects.
3. Some objects will lift better than others due to their shape and/or surface area.
4. Other uses for wind tunnels are to test race cars, passenger cars, and space-related items.

### Airfoils

1. The airfoil at a 70-degree angle moved up the wire.
2. The airfoil at a 40-degree angle moved up the wire more than it did at the 70-degree angle, and it moved more quickly.
3. The size of the lift force increases with the angle of the airfoil to the wind.
4. When the airfoil is flipped over, the air forces it to the ground because the curved surface of the wing was not on top.
5. From this experiment you can conclude that a wing needs to have the curved surface on top, and it needs to have an upward angle for the best lift.

The NASA "Why?" Files  
The Case of the  
Challenging Flight

## Segment 2

The tree house detectives continue their quest to win the Egg-tra-ordinary Plane Contest. To learn how aeronautical engineers conceive new and innovative ideas for airplane designs, they turn to the technology of **CU SeeMe TV** and visit with Burt Rutan. The tree house detectives learn how Mr. Rutan thinks “outside of the box” to develop new aircraft designs. They are introduced to several unique designs such as the *Proteus*, the *Voyager*, and the *Long EZ*. Next, the tree house detectives go to meet a pilot for U.S. Airways to learn about thrust. As a result of their investigations, they begin to question if weight affects thrust. To check out their theory, they e-mail a school in the NASA “Why?” Files Kids’ Club that is conducting experiments on weight and thrust. To further their knowledge of how weight affects thrust, they are invited aboard an aircraft carrier, the *USS Theodore Roosevelt*. The tree house detectives are flown onboard and introduced to an aircraft carrier’s catapult system. They just happen to run into Dr. D, who is on the carrier conducting experiments of his own. Dr. D helps the tree house detectives bring it all together for a better understanding of thrust. As they are catapulted off the carrier at a speed of 160 mph in less than 3 seconds, they learn firsthand about the force of thrust!

### Objectives

---

The students will

- understand Bernoulli's Principle.
- learn the importance of creative thinking and design.
- learn that thrust is a force that is needed to overcome gravity and weight in so that a plane can fly forward through the air.
- learn that weight affects thrust.
- learn how a catapult system helps thrust a plane off the flight deck of an aircraft carrier.
- compare the length of an airport runway to that of an aircraft carrier's catapult.
- relate how the length of a runway affects the amount of thrust needed.

### Vocabulary

---

**aerodynamics** - the study of the motions and forces of gases on an object

**aircraft carrier** - a large naval ship with storage and service facilities for aircraft and a long flat deck on which airplanes can take off and land at sea

**air pressure** - the weight of air pressing on a surface

**Bernoulli's Principle** - states that the pressure in a moving stream of fluid is less than the pressure in the surrounding fluid

**catapult** - a mechanism for launching aircraft without a runway or with a short runway, as from an aircraft carrier

**cylinder** - a round chamber through which a piston moves

**dihedral angle** - angle that is formed by the intersection of an airplane's wing and the fuselage, creating a "V" shape

**nuclear reactor** - a device in which a chain reaction is begun and controlled with the production of heat typically used for power generation

**pitch** - the angle between the nose of an aircraft and the horizon. The nose pitches "up" or "down" in relation to level flight.

**piston** - a solid cylinder or disk that fits snugly into a larger cylinder and moves back and forth under fluid pressure

**roll** - one of the three axes of motion for an aircraft; roll raises the wings of the aircraft up or down

**runway** - a strip of usually paved level ground on which aircraft take off and land

**second law of motion** - force = mass X acceleration ( $f = m \cdot a$ ). An unbalanced force accelerates an object in the direction of that force. The larger the force, the greater the acceleration. The mass of an object also determines its acceleration. The greater the mass, the less the acceleration.

**shuttle** - metal object that connects the plane to the catapult system

**stability** - a measure of how hard it is to knock an object off balance

**yaw** - one of the three axes of motion for an aircraft; yaw moves the nose of the aircraft side to side



## Video Component (15 min)

### Before Viewing

1. Briefly summarize the events in segment 1 with the students.
2. Ask the students how learning about the history of flight helped the tree house detectives in their endeavor to build a better plane. Discuss how we can learn from other people's mistakes and build on their accomplishments.
3. Introduce the vocabulary for segment 2. Assign each student a word to look up in the dictionary. Have the student share the definition with the class in the form of an illustration or other medium of their choice.
4. Review scientific inquiry and predict what steps the tree house detectives will take next in the process.

### After Viewing

1. Discuss the questions that are asked at the end of the second video segment.
  - Will the tree house detectives change the mode of thrust for their plane?
  - Do they still need to investigate drag?
  - Can they combine all that they've learned so far to make a plane fly faster and farther?
2. Continue to guide the students in modifying and adding to the K-W-L chart.
3. Continue working with the display board to reinforce the investigation steps that the tree house detectives are taking to solve the problem. Point out that the detectives frequently stop to summarize what they know and discuss what they have discovered to see if they need to change their hypothesis.
4. Catapults are discussed in this segment due to the short runways on aircraft carriers. Have your students investigate the history of catapults. The use of this technology has varied widely from supersonic jets to pumpkin launching.
5. If you have older students, you might want to access activities from the *Exploring Aeronautics CD*, enclosed with this guide. You can access the web site at <http://www.exploringaerospace.arc.nasa.gov>
6. Runway lengths vary widely depending on their uses. Have your students investigate their local airports to find out what kinds of aircraft land there.
7. Choose from the activities in this guide or on the web site to help reinforce the concepts and objectives being emphasized in segment 2.

### Careers

aeronautical engineer  
inventor  
commercial airline pilot  
sailor  
nuclear physicist  
military fighter pilot  
flight engineer  
copilot  
flight attendant  
cargo loader  
air traffic controller  
aircraft engine mechanic

## Resources

---

Asmiov, Isaac and Elizabeth Kaplan: *How Do Airplanes Fly?* Gareth Steven's Inc. (1993), ISBN: 0836808002

Baker, David: *Navy Strike Planes*. Rourke Enterprises, Inc. (1989), ISBN: 0865925348

Burkett, Molly: *Pioneers of the Air*. Barron's Educational Series, Inc. (1998), ISBN: 0764106333

Collins, John C.: *The Gliding Flight: 20 Excellent Fold and Fly Paper Airplanes*. Ten Speed Press. (1989), ISBN: 0898153131

Doherty, Paul and David Learmont: *The Eyewitness Visual Dictionaries: Flight*. DK Publishing, Inc. (1993), ISBN: 1564581012

Green, Michael and Gladys Green: *Aircraft Carriers*. Friedman, Michael Publishing Group, Inc. (1999), ISBN: 1567997228

Hardesty, Von and Dominick Pisano: *Black Wings: The American Black in Aviation*. Smithsonian Institution Press (1988), ISBN: 087474511X

## Web Sites

### **United States Navy**

Click on "Our Ships," then on "Carriers" to see digital images of aircraft carriers and discover unique facts about these fascinating floating cities at sea.  
<http://www.navy.mil>

### **University of California, Berkeley: Museum of Paleontology - Vertebrate Flight**

Provides a comprehensive look at flight, including topics such as evolution of flight, origins of flight, basic flight physics, and gliding and parachuting. Pictures are provided that implement animals in the discussion of the basic flight principles.  
<http://www.ucmp.berkeley.edu/vertebrates/flight/enter.html>

### **NASA - Ask-a-Scientist**

Tap into the wealth of knowledge NASA scientists have by submitting a question in the areas concerning space science, earth science, life science, rockets, the shuttle, and robotics.  
<http://science.msfc.nasa.gov/FAQ/ask-a-scientist.htm>

### **USS Theodore Roosevelt - CVN - 71**

Official web site of the aircraft carrier, *USS Theodore Roosevelt*.  
<http://www.spear.navy.mil/tr/>

---

## Activities and Worksheets

---

**In the Guide** | **Bernoulli and More Bernoulli . . . . .28**

Six easy and simple experiments that explain Bernoulli's principle.

**Thinking Out of the Box . . . . .29**

Design a futuristic plane for NASA that is like no other.

**Flight Plan . . . . .30**

File a flight plan and estimate flying time as you plan an airplane trip.

**Thrust Experiment . . . . .32**

Perform the experiment from the video to discover how weight affects thrust.

**Clear for Launch . . . . .33**

Build a delta wing flyer and launch it from your own catapult.

**Answer Key . . . . .36****On the Web**

You can find the following activities on the Web at <http://whyfiles.larc.nasa.gov>.

**Airport**

An activity to design and build a tabletop airport.

## Bernoulli and More Bernoulli

---

Try one or more of these activities to better understand Bernoulli's Principle.

### Tent with a Straw

Fold a 20-cm X 13-cm piece of paper in half to make a tent. Place the paper tent on the desk. Using a straw, blow under the tent and observe what happens. Blow harder and observe what happens. Try blowing hard against the side of the tent and observe what happens.

---

### Balloon Blow

Blow up two balloons and tie off the ends. Cut two pieces of string 30 cm each. Tie one end of each string to each balloon. Hold the balloons in front of you by the strings about 5 cm apart. Blow very hard between the two balloons and observe what happens. What did the balloons do?

---

### Ping Pong

Place two ping pong balls on a table about 2 cm apart. Using a straw, blow very hard between the two balls and observe what happens. Did the balls move closer together or farther apart?

---

### Paper Paper

Hold two pieces of notebook paper in front of you about 5 cm apart. Blow hard between the papers and observe what happens. Which way did the papers move?

---

### Stuck to It

Cut out a square of paper approximately 3 cm X 3 cm. Place the paper in the palm of your hand, and using your thumb and middle finger, hold a quarter (or nickel) about 1 cm above the paper. Place your mouth above the coin and blow hard. Observe what happens.

---

### Ball and Straw

Bend a flexible straw so that the short end is pointing up. Hold a ping pong ball over the opening of the straw and blow. Let go of the ball and observe what happens. What happens if you tilt the straw?

---

### Explanation

Air is pretty pushy stuff. It never pulls or sucks; it only pushes. Right now, air is pushing on you from every direction. This constant push of air is called air pressure. We are so used to air being around us that we don't even notice it. In the 1700's a Swiss mathematician named Daniel Bernoulli discovered that when flowing air or water changed its speed, its pressure also changed. In all of the experiments, the air speed was increased, creating a decrease in pressure. When the air pressure under the tent; between the balloons, papers, and balls; and under the paper with the coin was decreased, the air on the other sides had higher pressure. This higher pressure pressed inward, causing the tent to fall to the table and the balloons, pieces of paper, and ping pong balls to go together. In "Stuck to It" the air quickly moves between the paper and the coin, creating low pressure; therefore, the air pressure below the paper is greater and "holds" it against the coin. Now you describe what is happening with the ping-pong ball and straw.

---

### Misconceptions

Many books state that air speeds up over a wing because it has farther to travel than air moving under the wing. This statement implies that air separates at the front of the wing and must rejoin behind the wing, but this isn't true. Air moving over the top of a wing speeds up so much that it arrives behind the wing sooner than air that travels beneath the wing.

## Thinking Out of the Box

Scientists, designers, engineers, and many others have to be creative in their thinking as they develop new ideas and designs. You have to cast off the old way of doing things and try to free your mind for innovative ideas. So clear out the old ideas and get ready for the new. Your mission for this lesson is to help NASA design a new airplane for the future. The field is wide open for your design. You decide what the plane should look like, how it should fly, how long it should fly, and its uses. First, you will want to brainstorm some ideas, and once you get an idea of your plane's design, draw your design on the grid below. Share your ideas and drawing with the class. Make a model of your plane for a great presentation.

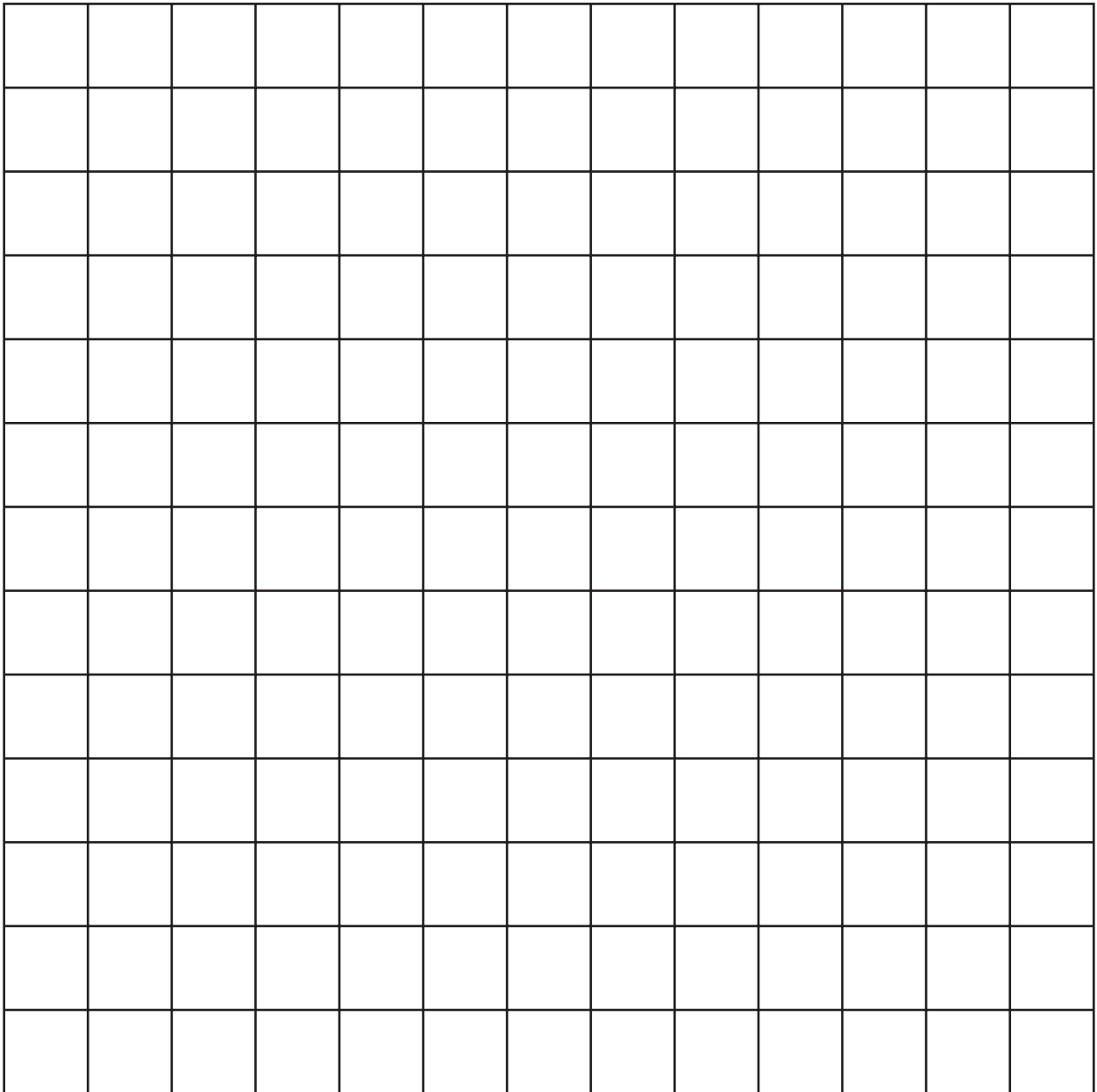

Scale: 1 square = \_\_\_\_\_

# Flight Plan

**Purpose** To learn about flight plans and airports.

## Materials

Aero-Chart  
ruler  
flight plan cards

- Procedure**
1. Hand out Aero-Chart (p. 31) and a flight plan card to each student.
  2. Discuss map features on Aero-Chart. Note airplane icon for measuring flight time and review how to use the scale.
  3. Ask the students to study the map and choose any departure and destination airport shown on the chart.
  4. Have the students mark their route on the map by connecting the lettered dots. Tell the students that routes don't have to be direct, but they should consider other factors that might influence their route choice such as mountains or restricted flying areas.
  5. Using the time icon on the chart and their ruler, have the students determine the amount of time the flight will take. Enter the time on their flight plan card.
  6. Ask the students to decide upon a departure time and add the flight time to determine the arrival time. Add this information to the flight plan.
  7. Have the students complete the remainder of the flight plan card.
  8. Share flight routes and flight plans as time allows.

- Conclusion**
1. What were factors that you considered in your choosing your route?
  2. If after takeoff you discovered that your plane only had enough fuel to fly for 2 hours, could you land at your destination? If not, what would you do? Where would you land? Explain why.

- Extension**
1. Students draw their own Aero-Chart and file a flight plan.
  2. Students can create a scale for distance for the Aero-Chart and measure the distance from each airport.

## Pilot's Flight Plan

Aircraft Number \_\_\_\_\_ Departure Time \_\_\_\_\_

Departure Point \_\_\_\_\_

Route of Flight \_\_\_\_\_

Destination \_\_\_\_\_

Estimated Time En Route \_\_\_\_\_ Arrival Time \_\_\_\_\_

Color of Aircraft \_\_\_\_\_

Name and Address of Pilot \_\_\_\_\_

\_\_\_\_\_

# Flight Plan (continued) Aero Chart

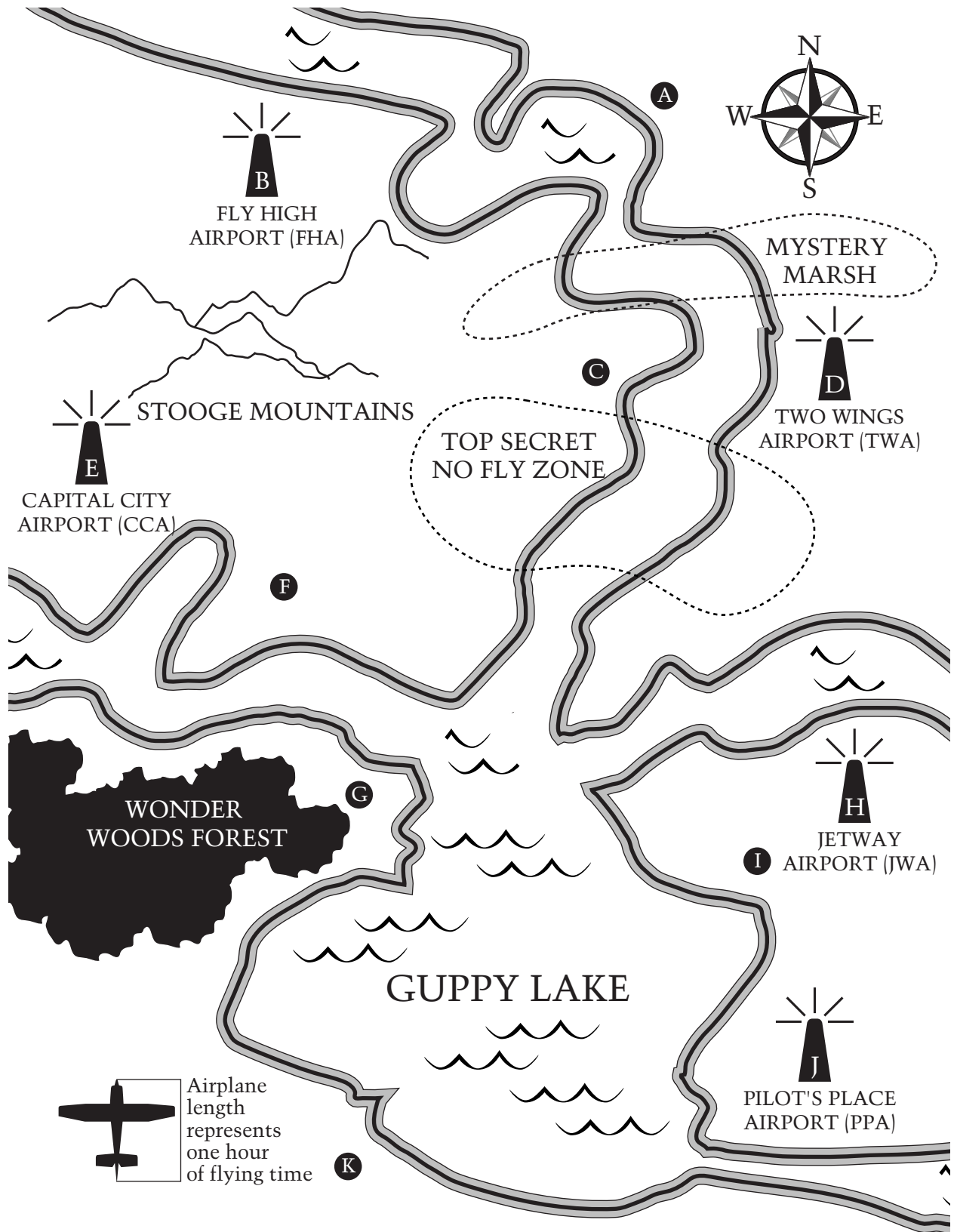

# Thrust Experiment

## Purpose

To determine if weight affects thrust.

## Procedure

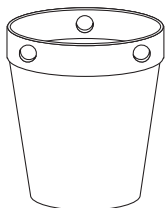

Diagram 1

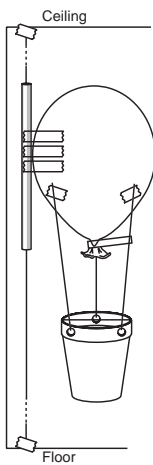

Diagram 2

1. Measure the distance from the ceiling to the floor.
2. Add 15 cm to that measurement and cut a length of string for that amount.
3. Tape or tie the string to a spot on the ceiling.
4. Thread the straw onto the string.
5. Stretch the string taut and tape it to the floor.
6. Using a hole punch, punch three holes evenly spaced around the top of the cup. See diagram 1.
7. Cut three pieces of string 30 cm each.
8. Tie one string in each hole of the cup.
9. Blow the balloon up, but do not tie it off. Use a clothespin to keep the air from escaping until ready to release.
10. Position the cup under the balloon and tape the other ends of the strings to the balloon so that it looks like a hot air balloon with a basket under it.
11. Tape the balloon to the straw. See diagram 2.
12. Lower the balloon to the floor, count down, and release.
13. Mark how high the balloon rose on the string.
14. Measure and record.
15. Blow the balloon up again being sure that it is about the same size as before, but this time place 5 paper clips in the basket.
16. Repeat steps 12-14.
17. Repeat Steps 15-16 adding five paper clips at a time until the balloon will no longer launch.
18. Analyze data and draw a graph.

## Materials (per group)

balloons  
masking tape  
clothespin  
straw  
small paper cup  
(3-oz size)  
string  
scissors  
20 paper clips  
hole punch

## Data

Balloon launch	Launch height in cm from floor
1 with no paper clips	
2 with 5 paper clips	
3 with 10 paper clips	
4 with 15 paper clips	
5 with 20 paper clips	

## Graph

## Conclusion

1. What happened to the height of launch as you added weight?
2. Explain why this occurred.



# Clear for Launch

## Purpose

To learn how a catapult launches a plane.

## Procedure

1. To make the launcher, tie one end of a rubber band around one end of the wooden dowel. See diagram 1.
2. To make the fuselage of the plane, tape the two cardboard tubes together, end to end.
3. Place the ping-pong ball inside one end of the tube so that half the ball is visible outside of the tube and glue into place. This is the nose of the plane. See diagram 2.

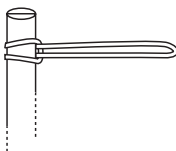

Diagram 1

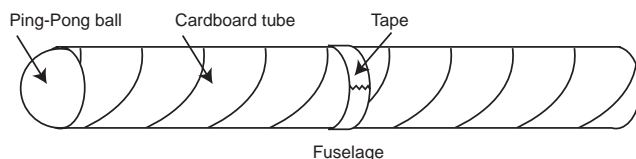

Diagram 2

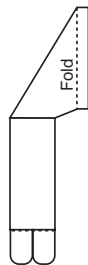

Diagram 3

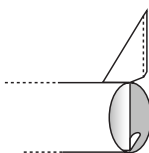

Diagram 5

4. Using the pattern (p. 35), trace a delta wing shape on cardboard and cut out. The wings should be the same length as the fuselage.
5. Trace and cut out the tail fin from cardboard (p. 35).
6. Fold flaps along dotted lines as indicated on pattern. See diagram 3.
7. Cut a rectangle of cardboard 23 cm by 14 cm.
8. On each 23-cm side of the rectangle, draw a line 1-cm from the edge. See diagram 4.
9. Fold along the lines to form flaps and glue cardboard over the fuselage, leaving flaps free.
10. Make a 4-cm slit through the top of the fuselage and cardboard at the tail end of the plane.
11. Carefully, slide the tail fin into the slit. See diagram 5.
12. Glue the flaps at the base of the tail fins inside the tube fuselage.
13. Center the fuselage over the delta wing and tape the cardboard flaps of the fuselage to the wings on both sides.
14. With adult help, trace and cut out the launching hook from balsa wood (p. 35).
15. With adult supervision, carefully cut a 2-cm slit in the underside of the fuselage 5 cm from the nose of the plane.
16. Place the hook in the slit. Glue in place and let dry. See diagram 6.
17. To launch your airplane, loop the rubber band over the hook under the nose. Hold the launcher in one hand and the plane in the other. Stretch the rubber band and tilt the plane upward slightly and release. ALWAYS LAUNCH YOUR PLANE OUTSIDE AND AWAY FROM OTHER PEOPLE.
18. Experiment with various sizes of rubber bands, measuring the distance that the plane traveled after launch with each rubber band. Record distances in your science journal.
19. Experiment with various angles of launch and record distances in your science journal.
20. Organize data into a chart or graph and share with class.

## Materials

2 cardboard tubes  
(4 1/2 in. long each)  
various sized rubber bands  
15 cm wooden dowel  
ping-pong ball  
thin cardboard or cardstock  
masking tape  
glue  
scissors  
balsa wood  
markers  
science journal  
pencil

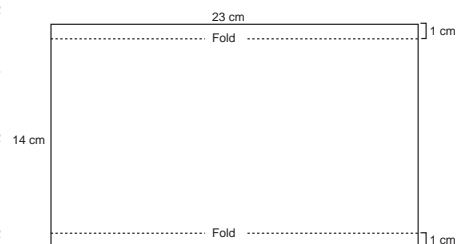

Diagram 4

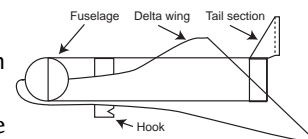

Diagram 6

## Clear for Launch (continued)

---

### Conclusion

1. Which rubber bands launched the plane the farthest? \_\_\_\_\_

\_\_\_\_\_  
\_\_\_\_\_  
\_\_\_\_\_

2. Explain why. \_\_\_\_\_

\_\_\_\_\_  
\_\_\_\_\_  
\_\_\_\_\_

3. How does your launcher compare to the catapult on the aircraft carrier? \_\_\_\_\_

\_\_\_\_\_  
\_\_\_\_\_  
\_\_\_\_\_  
\_\_\_\_\_

4. Explain what other variables you might change to make your plane launch farther? \_\_\_\_\_

\_\_\_\_\_  
\_\_\_\_\_  
\_\_\_\_\_

5. How does the shape of the wing affect the distance your plane travels after launch? \_\_\_\_\_

\_\_\_\_\_  
\_\_\_\_\_  
\_\_\_\_\_

6. How does the angle that you launch the plane from affect the distance it travels? \_\_\_\_\_

\_\_\_\_\_  
\_\_\_\_\_  
\_\_\_\_\_  
\_\_\_\_\_  
\_\_\_\_\_  
\_\_\_\_\_

### Extensions

1. Experiment with different shaped wings.
2. Add flaps to the wings and determine if they affect the distance that it travels after launch.
3. Make the plane out of other materials.

# Clear for Launch (pattern)

---

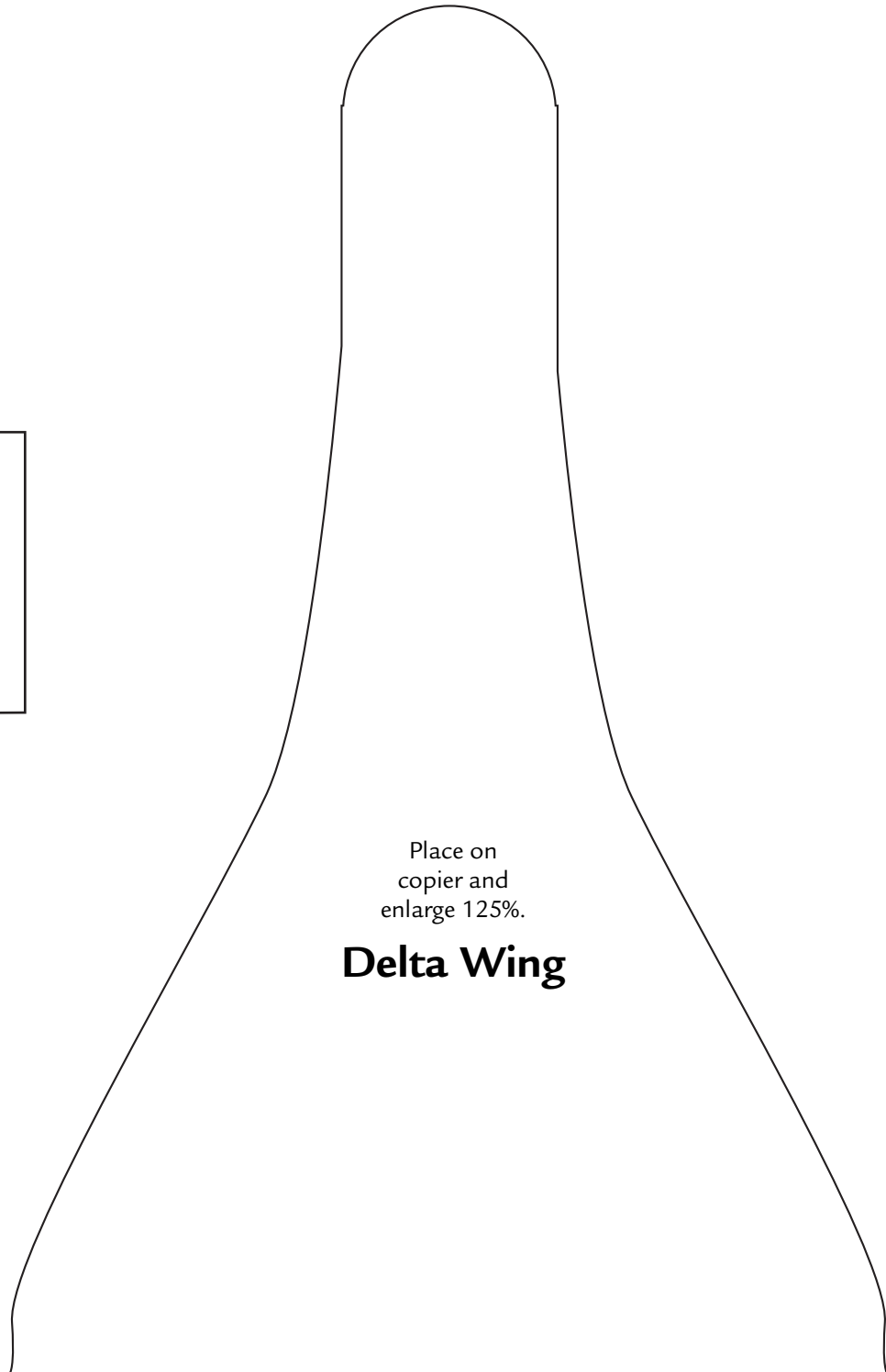
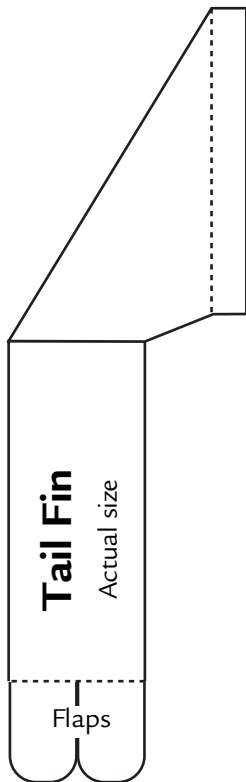

## Answer Key

---

### Thrust Experiment

1. As weight was added to the cup, the height of the launch was reduced.
2. Adding weight to the cup increased the amount of thrust needed to launch the balloon.

### Flight Plan

1. Some factors might include mountains, no fly zones, or length of time.
2. Answers will vary.

### Clear for Launch

1. Answers will vary.
2. There are a variety of factors about the rubber bands that could increase the distance that the plane traveled after launch. Some include the length of the rubber band, the thickness of the rubber band, and/or the ability of the rubber band to stretch.
3. Answers will vary, but should include information comparing the aircraft carrier's catapult system to the rubber band. The notched wood under the model plane is similar to the location on an airplane where it is connected to the shuttle. When a plane is launched on a carrier, steam builds and is released to power the pistons that jettison the plane to 160 mph in about 3 seconds. This launch can be compared to the pulling back of the rubber band (building up steam), and when you let go, you have released the energy in the rubber band to jettison the model.
4. Answers will vary, but may include changing the wing shape or designing the plane out of lighter weight materials.
5. The shape of the wing is important to achieve maximum lift. Some shapes will create more lift, therefore allowing the plane to travel farther.
6. The angle at which you launch the model plane will affect lift. Too much angle will make the plane fly in a straight up path, and the distance the plane travels will not be as great. Too little angle, and there will not be enough lift to fly very far.

The NASA "Why?" Files  
The Case of the  
Challenging Flight

## Segment 3

The tree house detectives are closing in on the four forces of flight. To learn more about weight and the center of gravity, they visit an electronic classroom to connect with NASA Dryden Flight Research Center. The information they learn from Dryden helps them place their wings in the optimum position for flight. The tree house detectives are amazed when they learn how a computer enables a plane, the X-29, to fly with wings that are placed on “backwards!” Dr. D helps the tree house detectives understand Newton’s first law of motion, and they begin to study the force of drag. They discover that nature is the key to understanding drag as they discuss “Biomimetics” with Ben Anders and learn how birds, insects, sharks, and other animals have aided in our knowledge of flight. The tree house detectives make a final stop at the NASA Langley Research Center to learn how new “smart” materials and composites reduce both drag and the weight of the plane. The tree house detectives realize that they must reduce the weight of their plane if they want to win the contest.

### Objectives

---

The students will

- learn how weight and the center of gravity affect stability.
- understand Newton’s first law of motion.
- discover how nature is the expert in reducing drag.
- learn that the weight of an airplane affects lift and drag.

### Vocabulary

---

**air resistance** - a type of drag that occurs as an object moves through the air

**“biomimetics”** - the study of how birds, insects, and marine animals overcome drag

**center of gravity** - distribution of weight around a balance point

**composite** - usually refers to a type of structure made with layers of fiberglass or fiberglass-like materials such as carbon fiber

**electronic classroom** - a classroom using two-way audio and video communications over telephone lines

**friction** - force that opposes the motion of an object

**Newton’s first law of motion** - an object at rest will remain at rest and an object in motion will remain in motion at a constant velocity unless an unbalanced force acts upon it

**range** - maximum flight distance

**rudder** - the primary control surface in yaw, it is usually hinged and attached to the trailing edge of the vertical stabilizer on an aircraft’s tail.

### Video Component (15 min.)

---

#### Before Viewing

1. Briefly summarize the events in Segment 2.
2. Review the forces of thrust and lift. Ask students to draw an illustration of how lift is created according to Bernoulli’s principle.
3. Introduce the vocabulary for Segment 3.
4. Compose a list of living things that fly and a list of those that do not fly. Compare and contrast the animals/insects. Discuss why some birds do not have the ability to fly. Discuss adaptations for flight and how an animal’s environment supports these adaptations.
5. Review the process of scientific inquiry. Ask the students to identify the steps that the tree house detectives used in their investigation in Segment 2. On the board or a transparency, make an outline of the steps. Identify these steps with the process of scientific inquiry. Tell the students that the process is not a step-by-step process.
6. Predict what will happen in Segment 3.

## After Viewing

1. Discuss the questions that are asked at the end of the third segment of the video.
  - Will the change in material to the foam egg carton help the plane fly farther?
  - What's the most important force of flight?
  - What will help the tree house detectives win the contest?
2. "Biomimetics" expert Ben Anders studies how drag affects fish, birds, and insects. Compare and contrast the shark's fin and bird's wing to the wings of an airplane? Ask if there are any special features of the shark's fins and/or the bird's wings that help to reduce the amount of drag? How might this study be applied to airplane wings?
3. This segment introduces the students to control surfaces. Reinforce the terminology with a model or a class diagram to show the rudder (steering or turning), ailerons (rolling or banking), and elevator (up and down). Ask the students what combination of flight surfaces result in yaw, roll, and pitch?
4. Have your students investigate the control surfaces that existed on early airplanes such as the Wright Flyer. Have students list the problems that early aviators might have encountered because of their planes' designs?
5. Continue to guide the students in modifying and adding to the K-W-L chart. Predict what the tree house detectives will investigate next and the outcome of the contest.
6. Choose from the activities in this guide to help reinforce the concepts and objectives being emphasized in Segment 3.

## Careers

test pilot  
structural engineer  
electronic classroom teacher  
"biomimetics"

## Resources

Kalman, Bobbie D.: *How Birds Fly*. Crabtree Publishing Co (1997), ISBN: 0865057680

Pallis, Jani Macari, Ph.D.: *The Big Book of Air and Space Flight*. McGraw-Hill (2000), ISBN: 0071348204

## Web Sites

### Plane Math

Provides on-line activities that will develop students' understanding of flight. Each of the activities includes the on-line lesson, an interview with the expert involved in the activity, group work that enhances problem-solving skills, and information addressing the national standards used and other possible extension ideas for the teacher or parent.

<http://www.planemath.com/activities/pmactivities4.html>

### NASA Glenn Research Center

Test your skills in aerospace science by solving a weekly riddle or trivia question posted on the web by NASA Glenn Research Center.

<http://www-psao.grc.nasa.gov/psaoquiz.html>

## Activities and Worksheets

---

<b>In the Guide</b>	<b>Fluttering Fun, Point of Balance . . . .41</b> Learn how an object's center of gravity can be changed.
	<b>The Commotion of Motion . . . . .42</b> Learn about Newton's first law of motion (inertia).
	<b>What a Drag! . . . . .43</b> Discover how shape affects drag.
	<b>On Nature's Authority . . . . .47</b> Observe flight in nature.
	<b>Bugs O'Copter . . . . .48</b> Practice controlling variables as you determine the rate of decent.
	<b>Falling Bridges, Structures and Materials . . . . .50</b> Create a structure that will be strong enough to hold 5 lb of liquid.

<b>On the Web</b>	You can find the following activities on the Web at <a href="http://whyfiles.larc.nasa.gov">http://whyfiles.larc.nasa.gov</a> .
	<b>Finding Your Center of Gravity</b> Weigh yourself and use a formula to find your own center of gravity.
	<b>Shapes of Nature</b> Create a mobile to compare and contrast shapes and designs of animals to airplanes.
	<b>Pitch, Roll, and Yaw</b> Demonstrate the six degrees of freedom of motion of flight



# Fluttering Fun, Point of Balance

**Purpose** To learn how an object's center of gravity can be changed.

- Procedure**
1. Trace the butterfly pattern on construction paper.
  2. Cut out the butterfly.
  3. Mold a small amount of modeling clay into a ball and press on a flat surface.
  4. Press a pencil into the clay with the eraser pointing up. See diagram 1.
  5. Place the butterfly on top of the pencil's eraser. Move the butterfly around to find the point where it will balance.
  6. Observe the position of the butterfly in relationship to the pencil eraser and record observations in science journal.
  7. Attach one paper clip to each of the butterfly's front wing tips. Move the clips until you can get the butterfly to balance on the tip of its head. See diagram 2.
  8. Observe and record observations in science journal.
  9. Reposition the paper clips to the back wings and locate the new balancing point. Record observations in science journal.
  10. Experiment with placing the paper clips in other locations on the butterfly and finding the balancing point.

## Materials

butterfly pattern  
construction paper  
pencil with a flat eraser  
modeling clay  
scissors  
paper clips  
science journal

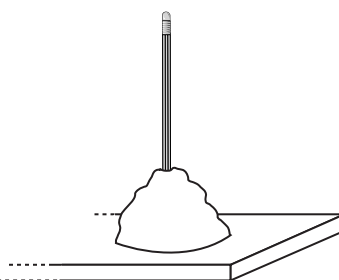

Diagram 1

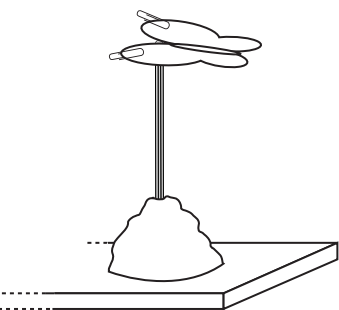
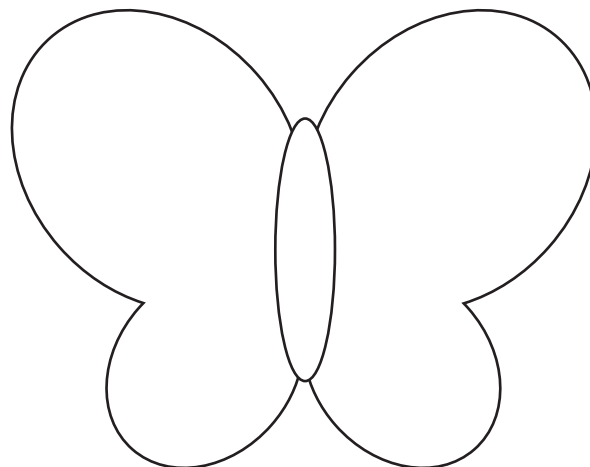

Diagram 2

- Conclusion**
1. Explain why the balancing point (center of gravity) changed as you moved the paper clips.
  2. What would happen if one wing of the butterfly were longer or shorter than the other wing?
  3. Is it important to have a symmetrically shaped object for this experiment? Why or why not?

- Extension**
1. Use thicker paper or cardboard and see how it affects the center of gravity.
  2. Dangle the paper clips from the wings instead of attaching them firmly.

**Explanation** The place on the butterfly where it can be balanced is called the center of gravity. This balance point is the point where all the parts of the butterfly exactly balance each other. All objects can be balanced and thus have a center of gravity. Adding paper clips to the wings of the butterfly added weight to the wings. Weight is a measure of the force of gravity. The weight of the paper clips moved the center of gravity from the center of the butterfly's body to its head.



Butterfly Pattern

# The Commotion of Motion

## Purpose

To learn about Newton’s first law of motion, which states that an object at rest will remain at rest, and an object in motion will remain in motion at constant velocity unless an unbalanced force acts upon it.

## Materials (per group)

- small toy car
- 30-cm X 45-cm piece of sturdy cardboard
- clay
- pencil
- tape
- 2 books
- science journal

## Procedure

1. Make a ramp on a smooth, flat surface by propping one end of the cardboard on one edge of the book and taping the other edge of the cardboard to the flat surface. See diagram 1.
2. About 20 cm from the taped edge of the cardboard, horizontally tape a pencil in place. See diagram 2.
3. Using the clay, make a small clay figure shaped like a person.
4. Gently place the clay figure on the hood of the small toy car, being careful not to “press” the clay to the car.
5. Position the car with the clay figure at the raised end of the ramp. See diagram 3.
6. Release the car and observe the clay figure as the car rolls down the ramp and collides with the pencil. Record observations in your science journal.
7. Repeat by placing the clay figure in the car, behind the car, and pressed firmly on the hood of the car. Observe and record your observations in your science journal for each position.
8. Raise the cardboard to a higher angle by placing the second book on top of the first book and repeat the experiment with the various positions of the clay figure. Observe and record your observations in your science journal.

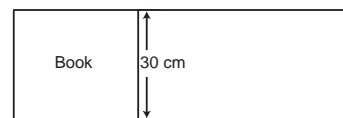
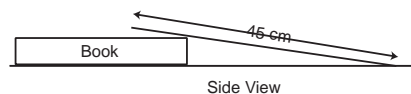

Overhead View  
**Diagram 1**

## Conclusion

1. What happened to the clay figure when it was on the hood of the car? Explain why.
2. Compare and contrast the other positions of the clay figure and explain the reactions.
3. Explain why it is important to wear a seat belt while riding in a vehicle.
4. What happened when you increased the angle of the cardboard? Why?

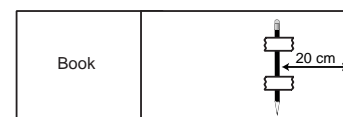

**Diagram 2**

## Explanation

Sir Isaac Newton called the tendency of objects to remain in motion or stay at rest inertia. Inertia is the property of matter that tends to resist any change in motion. The word inertia comes from the Latin word *iners*, which means “idle” or “lazy.” You feel the effects of inertia when you ride in a car or an elevator. If your mom or dad is driving down the road at 50 mph and has to come to a sudden stop, your body will continue to move forward even though the car has stopped. That is inertia. When you are in an elevator and push the button to go down several floors, your body will continue to “fall” for a second or two after the elevator stops. This is inertia and it is what makes you feel like you “lost your stomach!”

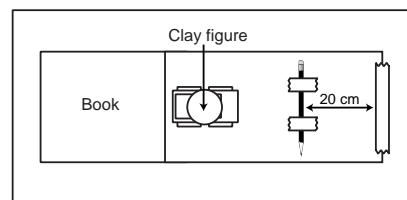

**Diagram 3**

# What a Drag!

## Purpose

To learn that shape affects the amount of drag on an object.

## Procedure

### Teacher Prep

- To make the drag stand (one per class), insert the wooden skewer 5 cm into the center of the foam block so that the measurement from the top of the wooden skewer to the bottom of the foam, where inserted, is 15 cm.
- Measure and cut a 10 cm X 1 cm piece of duct tape.
- Wrap the tape around the straw 2 cm from one end, making sure the tape is evenly wrapped and forms a level surface.
- Slide the straw over the wooden skewer until it makes contact with the foam block. See diagram 1.
- Place the box fan on a table or flat surface and plug in.
- Loop a piece of duct tape to make a double-sided tape. Attach the duct tape to the bottom of the foam block.
- Measure 1 m from the front center of the box fan and place drag stand at that point, making sure it is secured to the surface. See diagram 2.
- To assemble the drag arm, insert a flexible straw into the outer holes of a wooden ruler an equal distance from the center hole (pivot point).
- Secure straws to the ruler by placing two small pieces of duct tape around the top of the straw. See diagram 3.
- Cut out the shapes (pp. 45 and 46), bend on the dotted lines, and tape the edges together (cone, cube, tetrahedron, and pyramid). Note: Depending on the abilities of your students, this step may be completed by the students.
- Assess your students' knowledge of drag by asking them:
  - What is drag?
  - How would shape affect drag?
  - How does drag affect an airplane's ability to fly?

## Materials

block of heavy foam  
 10 cm X 10 cm X 15 cm  
 30-cm wooden skewer  
 duct tape  
 metric ruler  
 scissors  
 wooden ruler with holes  
 flexible drinking straws  
 box fan with three speeds  
 clear tape  
 shape patterns (p. 45 and 46)  
 science journal  
 glue (optional)

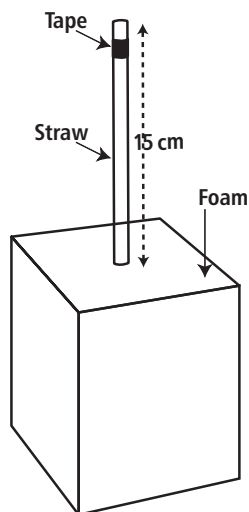

Diagram 1

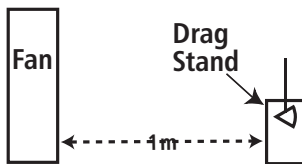

Diagram 2

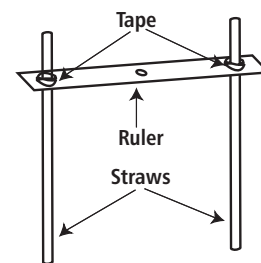

Diagram 3

# What a Drag! (continued)

12. Have students copy this Data Chart in their science journals.

Data Chart

Shape	Cone	Cube	Pyramid	Tetrahedron
Cone				
Cube				
Pyramid				
Tetrahedron				

Note: Discuss a matrix and why some of the spaces in the chart will be either duplicated or not used. For example, you will not test a cone and a cone because they are the same shape.

13. Beginning with the cone and the cube, attach shapes to the bottom of each straw using clear tape. See diagram 4.
14. Place the drag arm onto the drag stand by placing the ruler over the straw on the drag stand. See diagram 5.
15. Ask the students to predict which shape will have the most drag. Record their predictions in their science journals.
16. Turn the fan on low speed.
17. Observe and note which shape moves closer to the fan. This shape will be the one that has the least amount of drag. Record the shape that had the least amount of drag on Data Chart.
18. Compare student predictions with the results. Discuss.
19. Repeat steps 12-17 with the following combination of shapes:
  - cone and pyramid
  - cone and tetrahedron
  - cube and pyramid
  - cube and tetrahedron
  - pyramid and tetrahedron
20. Using the data from the Data Chart, ask the students which shape had the least amount of drag (the shape that appears in the chart the most often).

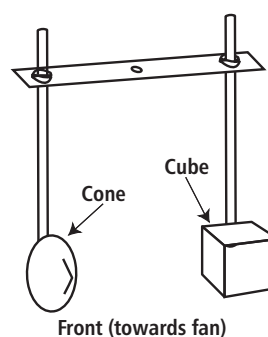

Diagram 4

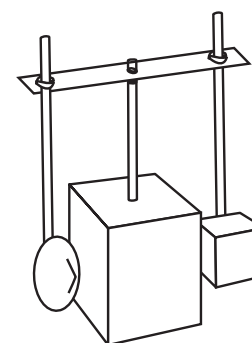

Diagram 5

## Conclusion

1. Does shape affect drag? Why or why not?
2. Would changing the size of the shape affect the outcome of this experiment? Why or why not?

## Extensions

1. Design a vehicle for NASA, determining which shape would have the least drag? Have students draw a picture of their vehicle and justify their design.
2. Discuss how the shape of an object would be affected by drag in space.
3. Cut out various sized squares of cardboard (10 cm, 20 cm, 40 cm, and 60 cm). Have students stand in front of the box fan holding each square one at a time to feel how the size of an object affects drag. The larger squares should “push” on the students more than the smaller squares. Discuss why.

# What a Drag! (patterns)

Photocopy at 125%.

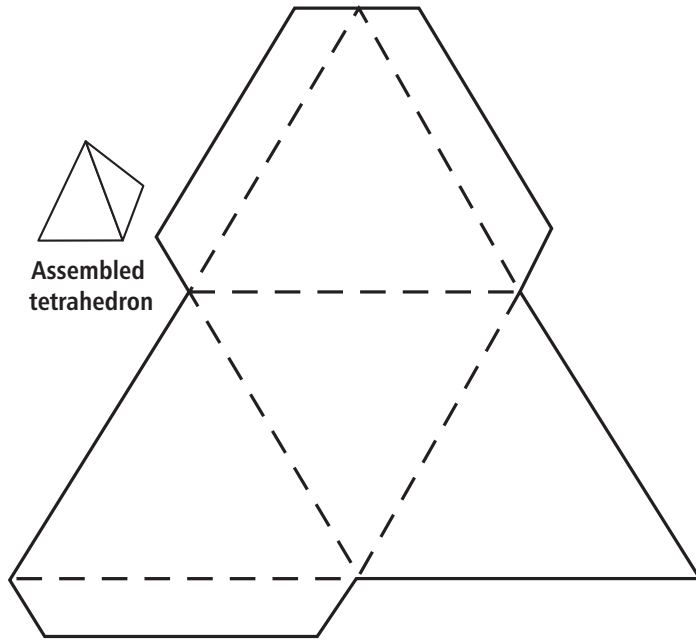

Assembled tetrahedron



Assembled cone

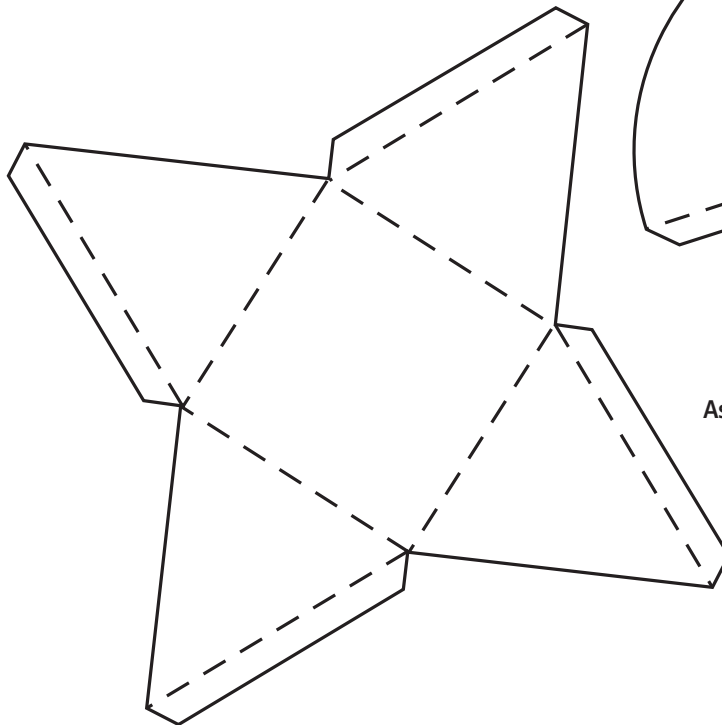
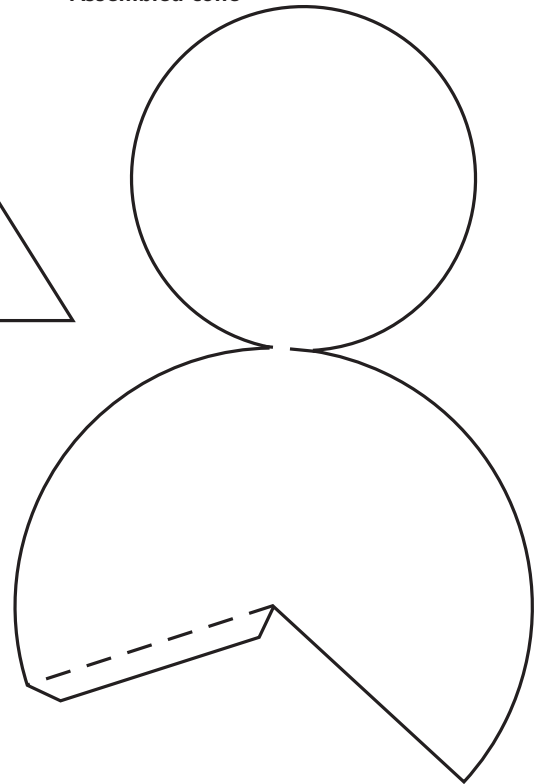

Assembled pyramid



# What a Drag! (Patterns)

Photocopy at 125%.

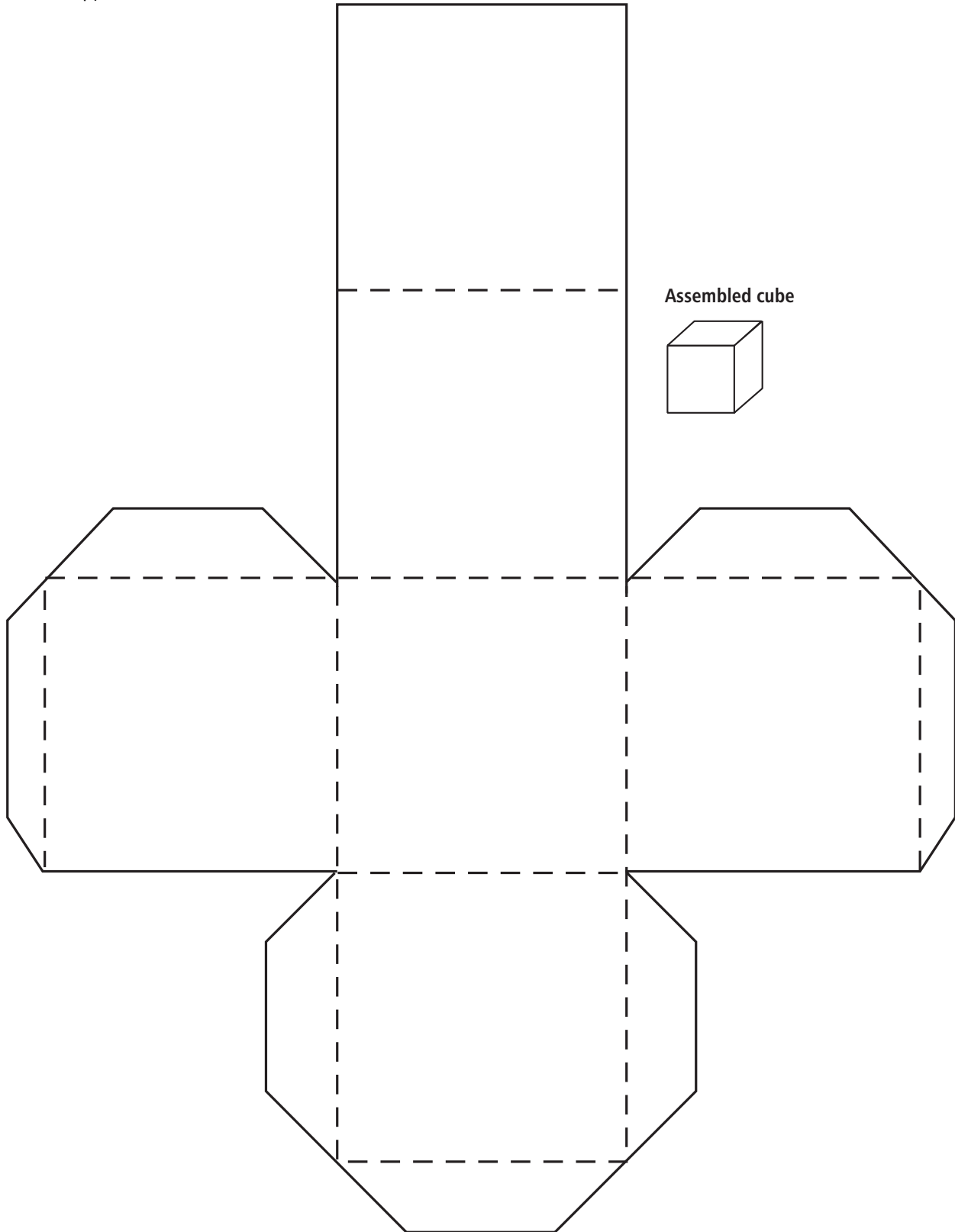

# On Nature's Authority

**Purpose** To observe flight in nature.

**Procedure** 1. In your science journal, draw a chart similar to the one below with space for 10 or more leaves, petals, or seeds.

Name or Picture of Leaf, Petal, or Seed	Maneuvers		
	Drop	Toss	Twirl

## Materials

assortment of leaves, petals, and seeds of different shapes and sizes from various plants  
science journal  
pencil

- Gather an assortment of leaves, petals, and seeds.
- Decide how to sort your leaves (by color, shape, size, and so on) and make piles as you sort.
- Choose a pile and a leaf from that pile. Write the name or draw a picture of the leaf.
- Drop the leaf and record how it responded after it was dropped.
- Toss the leaf and record how it responded after it was dropped.
- Twirl the leaf and record how it responded after it was dropped.
- Continue dropping, tossing, and twirling the remainder of the leaves. Observe and record your observations.
- Discuss how each leaf responded. Did it glide, float, or just drop to the ground?
- Re-sort your leaves according to the new data that you have obtained.

**Conclusion**

- How did the piles differ from the original sorting and the second sorting?
- What were some characteristics of the leaves, petals, or seeds that glided?
- Why did some just drop to the ground?
- What would happen if you dropped two identical leaves but one had the stem removed? Explain.

**Extensions**

- Toss a fresh leaf and compare its response to a leaf of the same kind that has been dried.
- Build a glider using the various leaves, petals, and seeds.

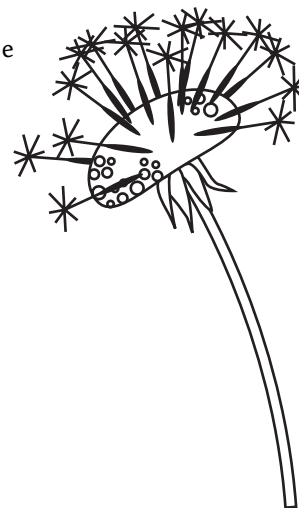

# Bugs O'Copter

## Purpose

To practice controlling variables to determine rate of decent.

## Procedure

1. You will need 4 Bugs O'Copters. To make Bugs ready to fly, cut pattern (p. 49) along solid lines and fold along dotted lines. Fold flap A backwards, flap B forward, flap C backward, and flap D forward.
2. Label your Bugs 1, 2, 3, and 4.
3. Set stopwatch to zero. Note: You will start the stopwatch when your partner lets go of Bugs and stop the stopwatch when Bugs hits the ground.
4. Working with your partner, hold Bugs #1 1.5 m (150 cm) from the floor and drop while your partner times its descent. See diagram 1.
5. Record time in your science journal.
6. To determine the average rate of descent, repeat Steps 4-5 for two more trials and average your data.
7. Calculate the rate of descent by using the formula  $R = d/t$  (Rate = distance divided by time) and record in your science journal.

$$\frac{\text{avg. rate of decent}}{\text{distance (150 cm)}} = \frac{\text{time (\# seconds)}}{\text{time (\# seconds)}}$$

8. On Bugs # 2, change a variable by bending or folding a portion of each ear and repeat steps 3-7.
9. Change the variable of distance by decreasing the height from the floor to 1 m (100 cm) and repeat steps 3-7 for Bugs #1 and #2.
10. Add 1-3 paper clips to Bugs #3 and repeat steps 3-7.
11. Determine a variable of your choice to change and repeat steps 3-7 on Bugs #4.
12. Create a graph showing the rate of descent for each variable tested.

## Conclusion

1. Did all Bugs drop the same? Why or why not?
2. What were the variables that you changed in each experiment?
3. Why is it important to keep all other variables constant during an experiment?
4. Calculate the average speed for all the Bugs.
5. Compare your Bugs O'Copter with other leaves, animals, or seeds in nature.

## Extension

1. To determine the number of rotations the Bugs O'Copter makes as it descends, (1) tape a piece of cassette ribbon (100 cm) to the bottom of Bugs, (2) stand on the loose end of the ribbon and pull Bugs up so that there are no twists in the ribbon, and (3) drop Bugs as usual. Count the number of twists in the ribbon to determine the number of rotations. Vary the height. See diagram 2.

## Materials

scissors  
4 Bugs O'Copters  
paper clips (for weights)  
stopwatch  
meter stick  
science journal

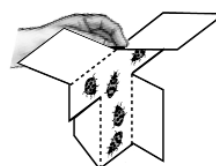

Diagram 1

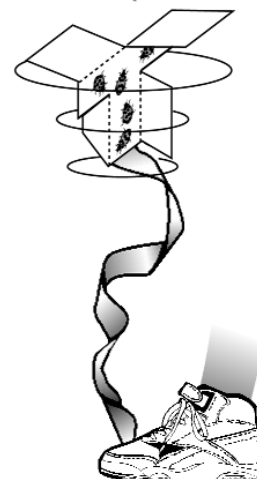

Diagram 2



## Bugs O'Copter (continued)

2. After the bug is dropped, construct a bar graph that shows the relationship between the height and the number of twists.
3. Experiment with various weights of paper and graph the results.
4. Have students determine relationships between the weight, height of launch, shape, and the length of the "blades."
5. Have students determine if the "blades" turn in a clockwise or counterclockwise direction.
6. Compare the flight of Bugs to that of a maple seed or dandelion.

### Explanation

Your Bugs O'Copter spiraled down, demonstrating its natural gliding flight that is similar to the leaves, petals, and seeds in nature. It changed speed and maybe even direction when you changed the variables. As you observe nature, you will see that no two species of leaves, petals, or seeds are exactly the same. Nature has changed the variables so they all have their own unique characteristics that suit them best for their environment. When conducting flight research, scientists observe the characteristics of objects in nature and how they glide. Scientists will sometime try to duplicate their observations and then change various variables to determine what would work best for a glider, plane, or space shuttle.

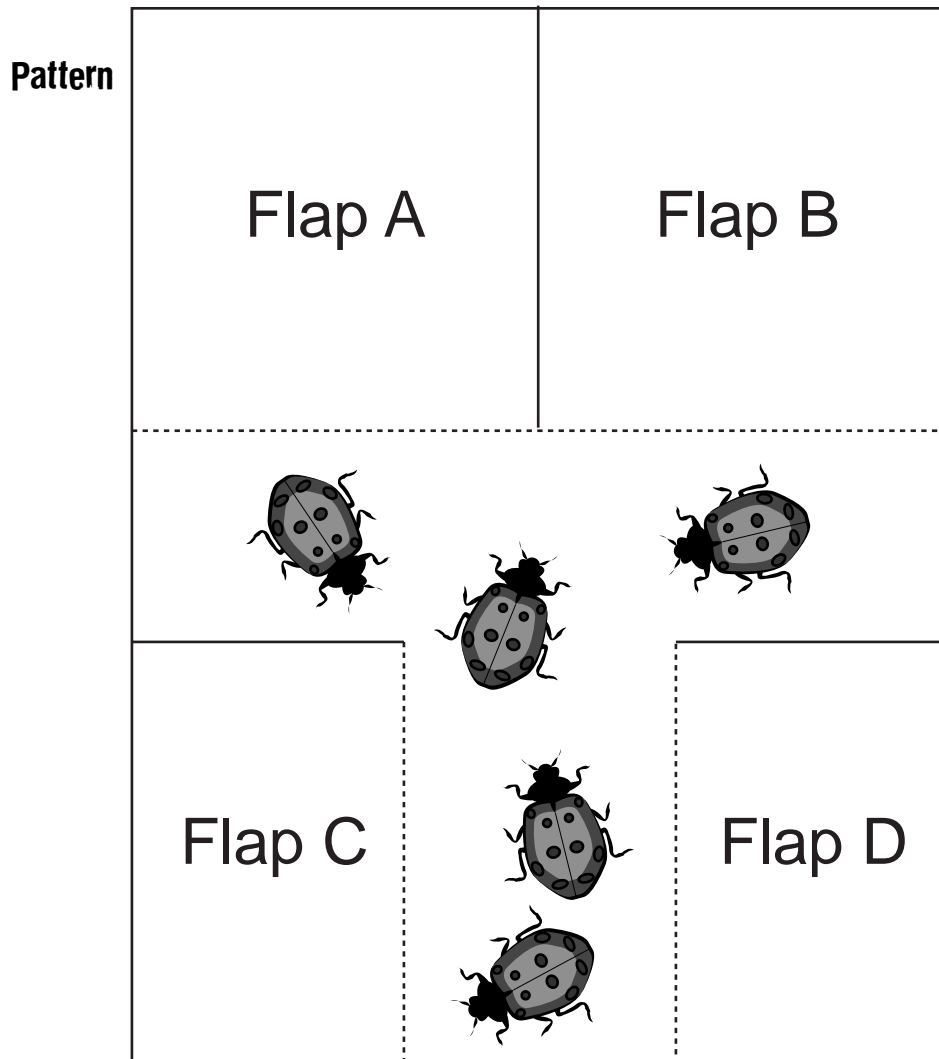

# Falling Bridges, Structures and Materials

**Purpose** To learn how different materials vary in strength.

- Procedure**
1. In your science journal, brainstorm ideas for the design of a bridge that spans a distance of 30 cm between two books, will hold the weight of a 2-liter bottle of liquid (about 5 lb), and is constructed only from the materials provided.
  2. Discuss with your group the pros and cons of each design.
  3. Choose a design, gather the necessary materials, and construct the bridge.
  4. Once the bridge is complete, use the 2-liter bottle to test your bridge. If the bridge collapses, rethink your design and build again if time permits.
  5. The group who builds (in the shortest amount of time) a bridge that will hold the bottle wins the Structures Award!

## Materials

miniature marshmallows  
uncooked spaghetti  
drinking straws  
craft sticks  
glue  
tape  
2-liter bottle filled with water for testing bridge  
science journal and pencil  
2 books

- Conclusion**
1. Did your bridge hold the 2-liter bottle of water? Explain why or why not.
  2. How could you make your bridge structurally stronger?
  3. Why would an aeronautical or aerospace engineer be concerned about the strength of the materials used to make planes and space vehicles?
  4. Would an aeronautical engineer want a heavy material? Why or why not?

- Extension**
1. Have a contest to see whose bridge can hold the most weight.
  2. Add construction cost to the contest by placing a dollar value on each piece. For example, a marshmallow could cost \$100 and each piece of spaghetti \$25, and so on. Try to get the strongest structure for the least amount of money or set a budget and see who can finish on or under budget.
  3. Using a balance to weigh the bridges, see which bridge is the lightest but holds the most weight.

**Explanation** In aeronautical and aerospace engineering, structures and materials is a very important field. Vehicles designed and manufactured for flight must be strong but lightweight. Vehicles that fly are subjected to great amounts of stress during takeoff and landing, so they must be strong. However, to be fuel efficient, they must also be lightweight. The research performed at NASA Langley Research Center, featured in the video, discusses composites and smart materials that will make lighter, yet stronger materials for future aviation vehicles.

# Answer Key

## In the Guide

### Fluttering Fun

1. The center of gravity changed as the paper clips were moved because the weight was redistributed.
2. If one wing was longer or shorter than the other wing, the center of gravity would be different. The center of gravity would have to shift to balance the difference in weight from one side to the other.
3. No, it is not important to have a symmetrically shaped object. However, a symmetrically shaped object makes it easier to find the center of gravity because the weight is evenly distributed.

### The Commotion of Motion

1. The clay figure kept going forward when the toy car was forced to stop because the pencil blocked its path. Since the clay figure was not secured to the car, the clay figure continued in motion even though the car stopped. This is inertia.
2. If the clay figure is secured in or on the car, it will stop with the car. Depending on the size of the car and the figure, the figure may move forward a small amount even though it is secured.
3. It is important to wear a seat belt while riding in a car so that your body does not continue to move forward and into the windshield if the car should have to come to a sudden stop.
4. When the angle of the cardboard was increased, the speed of the car was increased. This increase in speed caused the clay figure to fly even farther. The greater the speed, the greater the inertia.

### What a Drag!

1. Yes, shape affects drag. A shape that is “aerodynamic” is more streamlined and does not “catch” as much wind as a shape that is not “aerodynamic.”
2. If all shapes were increased equally in size, the change would not affect the outcome of the experiment. Changing the size of one or two of the objects would change the surface area, and that change would be a variable that would affect the outcome of the experiment.

### On Nature’s Authority

1. Answers will vary.
2. Answers will vary but might include characteristics such as a curved surface, lightweight, and smooth surface.
3. Answers will vary but might include that the object had too heavy or too small a surface area to glide.
4. If you dropped two identical leaves with the stem removed from one, the heavier one would fall at a faster rate than the one without the stem.

### Bugs O’Copter

1. No, all Bugs did not drop the same because the variables were changed. Variables included adding weight, repositioning flaps, and changing the height from which it was dropped. All these factors contributed to slight changes in the way Bugs would fall as it was dropped.
2. For Bugs 2, the variable was that a portion of each ear was folded. For Bugs 3, the variable was the added weight. For Bugs 4, answers will vary depending on student’s choice.
3. In any experiment, a scientist attempts to test one variable and only one variable at a time to ensure that the results of the experiment are due to the variable being tested and not some hidden factor.
- 4-5. Answers will vary.

### Falling Bridges

1. Answers will vary.
2. Answers will vary.
3. An aeronautical or aerospace engineer wants to make materials strong so they can endure the stress of flight. They would want to make the materials lightweight so that they will save on fuel consumption.
4. An aeronautical engineer would not want a heavy material because it would take too much fuel to lift off and fly the plane.

## On the Web

### Finding Your Center of Gravity

1. The center of gravity should be different for both students because they are of various sizes and weights.

### Shapes of Nature

1. Answers will vary.
2. Scientists would want to study the wings or fins of an animal to try to improve on airplane design. Nature is the ultimate flying authority, and we can learn much by observing animals that fly or swim.
3. Various airplanes are designed for different tasks. A fighter plane, such as an F-18, would have very different shaped wings than a cargo or passenger plane.
4. Various birds use their wings for different functions. A bird such as an eagle needs to glide and swoop quickly to catch live prey, while a robin eats mostly insects and seeds.

### Pitch, Roll, and Yaw

1. Pitch is located on the lateral axes. Roll is located on the longitudinal axes.
2. Yes, this is the way that a pilot maneuvers a plane; however, he controls the degree to which the plane pitches, rolls, or yaws by using his ailerons, rudder, and elevators.



The NASA "Why?" Files  
The Case of the  
Challenging Flight

## Segment 4

The day of the contest is fast approaching, and as the tree house detectives review all they have learned, they feel confident about their entry into the contest. The modifications they have made to their plane have brought major improvement to their plane's flight capabilities. To bring it all together, the tree house detectives visit a Young Eagle's pilot who gives them a flying lesson. With their knowledge of flight, a modified plane, and a little luck, the tree house detectives are ready to thrust forward into aviation's hall of fame as the winners of the Egg-tra-ordinary Plane Contest!

### Objectives

---

Students will

- learn the function of rudders and elevators on an airplane.
- learn how synthetic vision will help pilots of the future.

### Vocabulary

---

**cockpit** - control center housing pilot, instrumentation, and navigational aids used in flying

**elevator** - surface on the horizontal part of the tail section that moves up or down to assist the aircraft in maintaining level flight and adjusting the pitch of the aircraft

**engine** - part of the aircraft that provides the power for takeoff and landing, and sustains flight

**synthetic vision** - system developed by NASA Langley Research Center in Hampton, Virginia, that uses satellite signals and global positioning systems to give a pilot an electronic picture that is an exact duplication of the physical terrain, including man-made structures. This system will enable pilots to fly in environments that have limited visibility, thus saving lives.

**yoke** - control device in the cockpit used to maneuver the plane that looks similar to a car steering wheel, which is used to maneuver the plane

### Video Component (15 min)

---

#### Before Viewing

1. Briefly summarize the events in Segment 3.
2. Discuss what the tree house detectives have investigated thus far and ask students if there is anything remaining that needs to be investigated.
3. Predict the outcome of the contest.

#### After Viewing

1. Continue working with the display board to reinforce the investigation steps that the tree house detectives took to solve the problem.
2. Choose from the activities in this packet and on the web site to reinforce the concepts being emphasized.
3. List safety concerns pilots and airports must consider when planes are flying in poor weather conditions. Discuss how aircraft technology has changed to make flying safer.
4. Compare and contrast how helicopters and airplanes fly.
5. Discuss how aviation has affected the movement of people and materials in history.
6. List the many jobs and careers that were created by the industry of flight.

## Resources

---

### Books

Grant, Donald, Nancy Krulik, and Gallimard Jeunesse: *Airplanes and Flying Machines*. Scholastic, Inc., (1992) ISBN: 0590452673

Hsu, Gery: *How to Make Origami Airplanes That Fly*. Dover Publications, Inc., (1992) SBN: 0486273520

### Publications

*Aeronautics: An Educator's Guide with Activities in Science, Mathematics, and Technology Education* is available in electronic format through NASA Spacelink, <http://spacelink.nasa.gov/products> or can be obtained from your local Educator's Resource Center.

### Videos

*Milestones of Flight* was produced by the National Air and Space Museum and is based on the museum's "Milestones of Flight" gallery. The video traces the history of flight from Langley's first attempts to the space shuttle.

*Transformation of Flight* is an animated video produced by the Smithsonian Institution that presents ten important air and spacecraft events in the history of flight from the Wright Brothers' first flight to the space shuttle program.

### Web Sites

#### Young Eagles Program

Get involved in the Young Eagles Program and help EAA (Experimental Aircraft Association) reach their goal of taking one million young people on an airplane ride. Locate the chapter nearest you.  
<http://www.eaa.org/youth/youngeagles.html>

#### Regional Educator Resource Centers (RERCs)

RERCs offer educators access to NASA educational materials. A complete list of RERCs is available electronically via NASA Spacelink.  
<http://spacelink.nasa.gov/ercn/>

#### The Earth to Orbit Program

Connects students with the work of NASA engineers by engaging them in related design challenges in their own classrooms. With some simple and inexpensive materials, students can participate in an exciting learning experience...the challenges of designing the next generation of space vehicles.  
<http://eto.nasa.gov/>

#### Flight Testing Newton's Laws

Aircraft are used to stimulate the student's interest in the physical sciences and mathematics. An explanation of Newton's Laws of Motion is offered for both students and teachers, along with an aeronautics guide for grades K-4. Information is also available on how to obtain copies of the videos for "Flight Testing Newton's Laws" from Dryden Flight Research Center.  
<http://trc.dfrc.nasa.gov/trc/index.html>

## Careers

---

researcher  
flight instructor

## Activities and Worksheets

---

<b>In the Guide</b>	<b>Anatomy of an Airplane . . . . .</b>	<b>.57</b>
	Use definitions to label the parts of an airplane	
	<b>Aileron or No Aileron . . . . .</b>	<b>.58</b>
	Learn how ailerons affect flight patterns	
	<b>Four Forces of Flight Game . . . . .</b>	<b>.61</b>
	Use the four forces of flight to help you be the first to reach Liftville airport	
	<b>Flying Word Search . . . . .</b>	<b>.63</b>
	Word search highlighting key vocabulary terms	
	<b>Rescue at Sea Game . . . . .</b>	<b>.64</b>
	Use the four forces of flight, probability, and coordinate pairs to rescue a stranded man on a deserted island	
	<b>The Egg-tra-ordinary Airplane . . . . .</b>	<b>.68</b>
	Construct a model of the plane featured in the video to have your own Egg-tra-ordinary plane contest	

**On the Web** | You can find the following activities on the Web at <http://whyfiles.larc.nasa.gov>.

**Battle of the Airplanes**  
Using the Internet, compare various airplanes.



# Anatomy of an Airplane

Use the definitions below to label the parts of the airplane.

**ailerons** - surfaces on the outer edge of a wing that move up and down

**cockpit** - control center where pilot, instrumentation, and navigational aids used in flying are located

**elevator** - surface on the horizontal part of the tail section that moves up or down to assist the aircraft in maintaining level flight and adjusting the pitch of the aircraft

**elevon** - an airplane control surface that combines the functions of elevator and aileron

**engine** - part of the aircraft that provides the power for takeoff and landing and sustains flight

**flaps** - retractable trailing edges of a wings that move down to increase wing surface and increase lift on take-off. Located closer to the fuselage than the aileron.

**fuselage** - body of an airplane, excluding the wing and tail section

**landing gear** - wheels or floats of an aircraft

**propeller** - twisted airfoil, or turning blade, powered by the engine and providing thrust

**rudder** - vertical part of the tail section that moves left or right to stabilize the aircraft during crosswind take-off and landing or in severe wind conditions

**spinner** - part of the shaft that covers the center of the propeller and helps smooth the airflow over the engine

**tail section** - section of the plane housing the elevator, stabilizer, fin, and rudder

**wing** - an airplane's airfoil, producing lift as the craft moves through the air. It has two movable controls: ailerons and flaps.

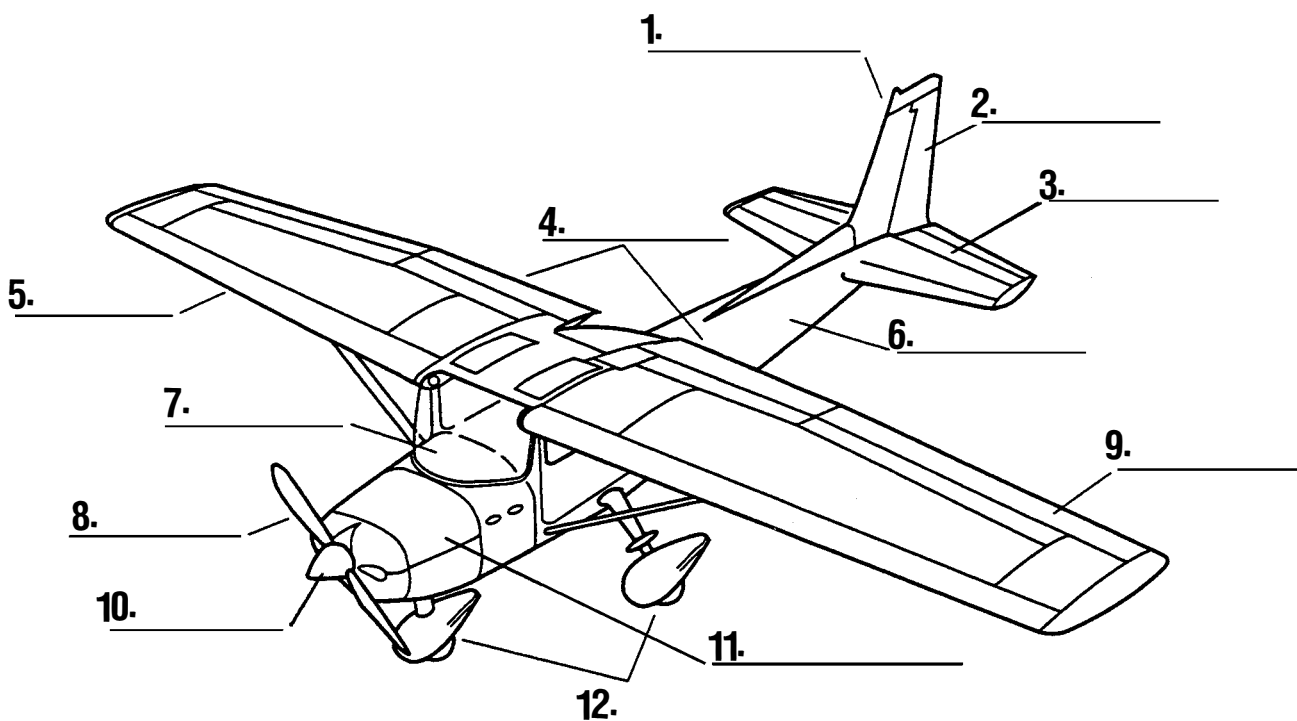

# Aileron or No Aileron

## Purpose

To learn how ailerons affect flight patterns. To learn how to collect, organize, display, and interpret data.

## Procedure

### Materials (per group)

- glider template
- heavy construction paper or foam
- scissors
- masking tape or duct tape
- science journal
- large enclosed area
- meter stick
- 4 index cards
- crayons

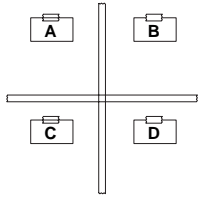

Diagram 1

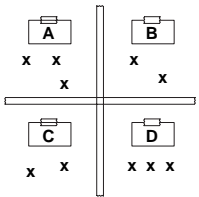

Diagram 2

1. Using the glider template (p. 60), trace and cut out glider.
2. Carefully cut a slot in the fuselage, following the guide on the template, and slide the wing into it.
3. Mark the dotted lines for the ailerons and the rudder, but do not bend at this time.
4. In a large, enclosed area such as a hallway, place a piece of tape on the floor, creating a start line for each group.
5. Measure 2.5 m from each start line and make this the center of the grid.
6. To make the grid, lay two pieces of tape, each 1 m long and perpendicular to each other.
7. Using index cards, mark the top left grid as section A, top right grid as section B, bottom left grid as section C, and bottom right grid as section D. Tape them in place. See diagram 1.
8. Draw grid in the science journal.
9. Aim at the center of the grid and throw the airplane. Using an “X,” mark in the science journal the actual grid that the plane landed in. See diagram 2.
10. Repeat for a total of ten trials.
11. Answer the following questions:
  - Which section of the target did the plane hit the most? The least?
  - How many landings were in section A? Section B? Section C? Section D?
  - Write a fraction to express the number of landings in each section.
  - Write a decimal for each of these fractions.
12. Following the sample section, organize your data in the table below.

Area	No. of Landings	Total Flights	Fraction	Decimal	Equation
Sample Sec.	4	10	4/10	0.4	4/10 = 0.4
Section A					
Section B					
Section C					
Section D					

13. Using the information from the table, create a circle graph below. Use a different color for each section.

### Key

- Section A
- Section B
- Section C
- Section D

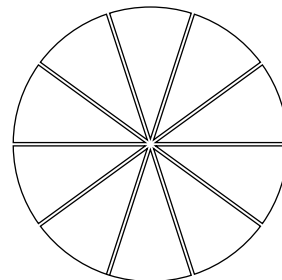

## Aileron or No Aileron (continued)

---

14. Discuss and analyze the data.
15. Discuss the purpose of ailerons and rudders on airplanes.
16. Predict how the landing patterns will change when the ailerons are bent.
17. Bend and fold the ailerons on the wing so that one aileron is bent up and one is bent down. Repeat steps 8-13.
18. Predict how the landing patterns will change when the rudder is bent.
19. Bend and fold the rudder on the tail and repeat steps 8-13.

### Conclusion

1. What effect, if any, did the ailerons have on the landing patterns?
2. What effect, if any, did the rudder have on the landing patterns?
3. Explain any similarities or differences in your graphs.
4. Using the graphs, what conclusions can be made about how ailerons affected the direction of the planes?
5. What happens when air hits the ailerons? How would pilots use ailerons on real planes?

### Extensions

1. Test various designs of paper airplanes.
2. Test various positions of the ailerons and rudders.

## Aileron or No Aileron (continued)

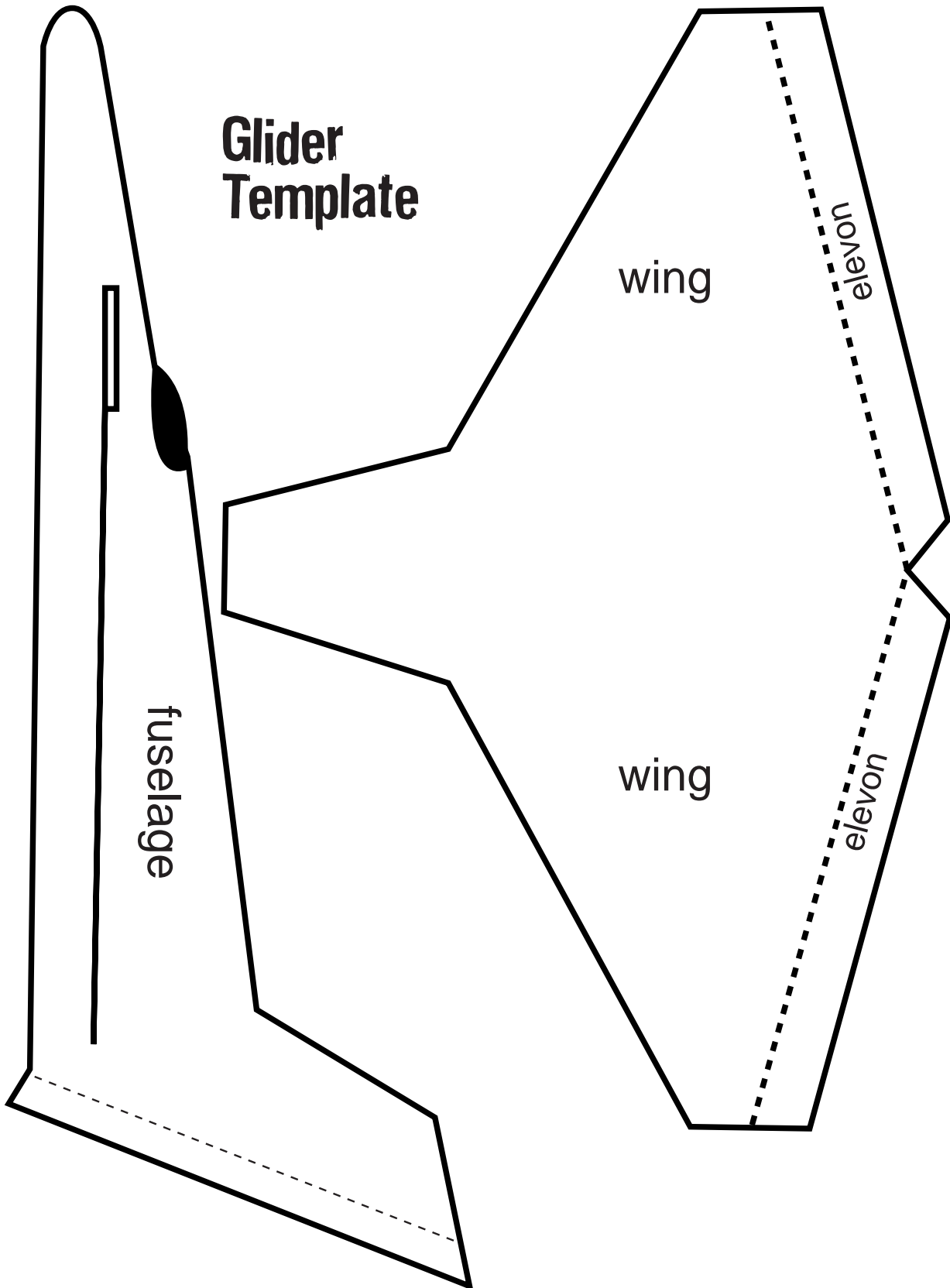

# Four Forces of Flight Game

**Purpose**

To have experience with the positive and negative forces of the four forces of flight.

**Game Objective**

To be the first to arrive at Liftville Airport after departing from Thrust City Airport.

**Materials**

- game board
- game pieces
- game cube

**Procedure**

1. The player whose birthday is closest to January 1 will be the player to start the game. The player with the next closest birthday will go second and so on.
2. To make the game cube, cut along solid lines and fold along dotted lines. Glue or tape tabs to the inside to form a cube.
3. Starting at Thrust City Airport, choose a runway for takeoff and roll the cube.
4. Move your airplane the number of spaces indicated.
5. The next player will now take his turn and so on.
6. If you land on a space that indicates a "problem," follow the directions given on that space.
7. Continue taking turns until a winner reaches Liftville Airport's runway.

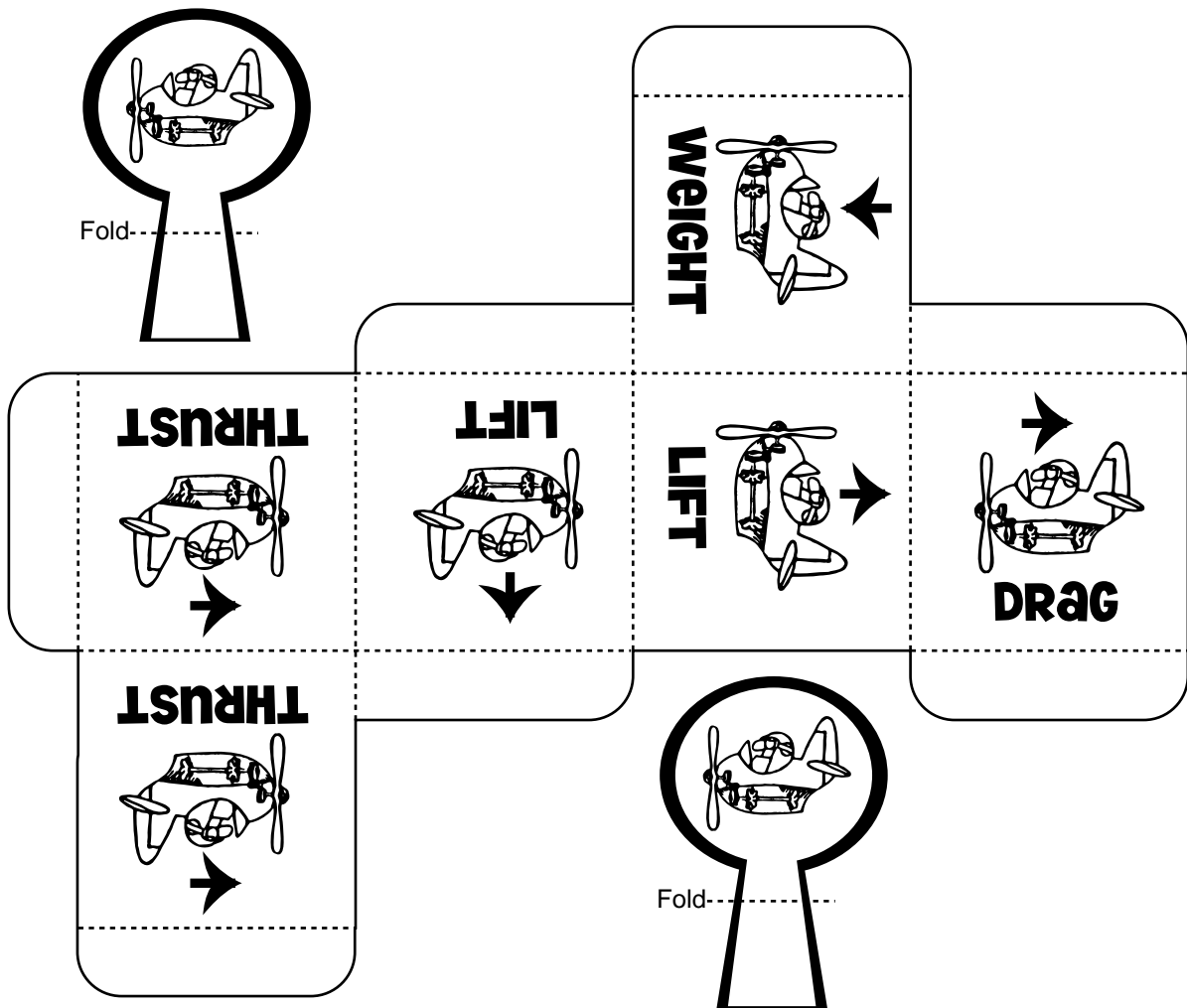

# Liftville Airport The End

Low fuel.  
Forward 1 space.

Rudder malfunction.  
Back 1 space.

Patterns full.  
Left 2 spaces.

Flap problem.  
Back 1 space.

Low on fuel.  
Forward 3 spaces.

Mountain ahead.  
Left 2 spaces.

Mountain ahead.  
Left 2 spaces.

NASA test area.  
Right 2 spaces.

Congested traffic.  
Left 2 spaces.

Ailerons stuck.  
Back 1 space.

Flap problem.  
Back 1 space.

Storm ahead.  
Left 2 spaces.

Engine light out.  
Back 1 space.

**lift = 3 spaces forward**  
**thrust = 4 spaces forward**  
**drag = 2 spaces back**  
**weight = 1 space back**

# Flying Word Search

Locate the key vocabulary terms in the word search below.

- |             |               |              |        |
|-------------|---------------|--------------|--------|
| aerodynamic | jet           | landing gear | tail   |
| aileron     | engine        | wind tunnel  | lift   |
| airplane    | flight        | pilot        | pitch  |
| airport     | control tower | runway       | thrust |
| cockpit     | fuel          | weight       | wings  |

E T A B A Y U B  
 N A I L Z A Z N A  
 I J X W M S Q I N O  
 G E O L I A T P W I C  
 N T C B S H K T X H D  
 E L A N D I N G G E A R  
 F L I G H T C K H F M D  
 C G N V G M L A W M A S S  
 C A B Z U R E W O T L O R T N O C P I T C H  
 L I R L E N N U T D N I W K N J T T R O P R I A  
 Q I N M D V D T M O I W X W N X N U F Y F M P Q C V Y  
 H E U A T M N F C J Y F K M H C D D I A A T T H Y F G  
 H G H N E X H H O S U Y H R X J Y A L L I C T E G Z E  
 D J P Y B E N Q C Y J N P J X R J P U N R T H G I E W W H R  
 T D X N P M K L K S L P F Q W G Z G P T Y M Y M H I Q Z  
 O E A D C P C F S E H K A G E Y S L Y C U W T S N M W  
 M R F L R B I C R F I K W B L Z U H A N B P K Y B G S T  
 A A S E L P E J T L E U F F P J W Y Q V N Z H J P V V S F  
 T S H A I N T R T C C R H D L O Q J W J E T O L I P L  
 T D P J G O S R I O G J K G O G C S L G H B C U X G  
 E X K M H R U F Q B S M J P U R  
 R N T E R M U V A A B N U  
 M C L H R S C Q W F V C  
 Y R I T S I D B C I X  
 A E A I O W H K A S K  
 W W X C J E F R I A  
 N V W Y R D P T R B  
 U N U R G S Z I L  
 R S R E W Q B L K  
 K Y X U L B N Z

# Rescue at Sea Game

## Purpose

To identify the positive and negative values of the four forces of flight. To collect, organize, and interpret data. To determine probability. To read, write, and plot ordered pairs on a grid.

## Materials (per group)

coordinate grid chart  
paper clip  
spinners A, B, C, and D  
science journal  
pencil  
crayons

## Procedure

1. Make a transparency of Diagram 1 (p. 65), and use it to review the four forces of flight. Point out that the arrows show the direction associated with each of the four forces.
2. Explain to the students that they will be playing a rescue at sea game and distribute a copy of the gameboard (p. 67) to each group.
3. Read the following mission to the students: The USS Theodore Roosevelt has just received a distress call. A person is stranded at the top of a mountain on an island that is close to the ship's location. Due to an approaching storm, you must quickly launch your helicopter and fly to the island to rescue the person.
4. Pass out the spinners (p. 66), and explain how the spinners determine the direction to move in the game. Lift (up one space), drag (left one space), thrust (right one space), and gravity/weight (down one space).
5. Ask the students to look at the game board and determine which direction they will need to fly to rescue the stranded person.
6. Review the spinners. How are they alike? Different? Have students predict which spinner will be the most helpful in their mission and why.
7. To test their predictions, spin each spinner 50 times and record the results in a tally table. Compile data into a bar graph. Note: To create a "spinner," have the students use a pencil point to hold a paper clip in the center of the circle and then spin the paper clip. See diagram 2.
8. Compare the results of the spinners and discuss each spinner's probability for the forces they will need the most in their mission (lift and thrust). Discuss the advantages and disadvantages of using each spinner. Have the students save their data and graphs to use during the game to help them choose a spinner to use for each turn.
9. Review ordered pairs and how to read, write, and plot points on a coordinate grid.
10. Ask students to predict how many spins it will take to reach the top of the mountain.
11. Using the example below, have the students create a table in their science journals to record their data.

Diagram 1 is on p. 65.

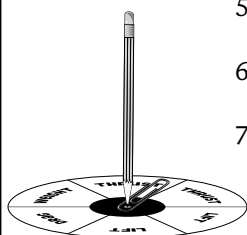

Diagram 2

Turn Number	Spinner Selected	Pointer Landed On	Direction Moved	Coordinate Landed On
Ex.: 1	D	Lift	Up	0, 1

12. Have the students choose a spinner, spin, and record data in the chart.
13. To plot their coordinates on the grid, have the students use a different color for each pilot. Remind students to color in the key on the coordinate grid chart.
14. Have the students continue playing the game, taking turns and choosing spinners. The first pilot to reach the stranded person on top of the mountain wins the game.



## Rescue at Sea Game (continued)

- Conclusion**
1. How did your predictions compare with the number of spins it actually took to reach the top of the mountain?
  2. How did the spinner's probability information help you determine which spinner to use for each turn?
  3. Using the coordinate graph chart, how did your flight path compare to your partner's? Explain why they were the same or different.

- Extensions**
1. Add fuel consumption to the problem. For example, give the students a limited number of gallons of fuel and have each space represent a certain number of gallons of fuel used for each turn. Have students predict the number of gallons they will need for the mission.
  2. Make a new game board that favors a different spinner.
  3. Make new spinners that would best suit the game.
  4. For advanced students, create a game board that would involve positive and negative integers and that would extend into other quadrants of the coordinate plane.

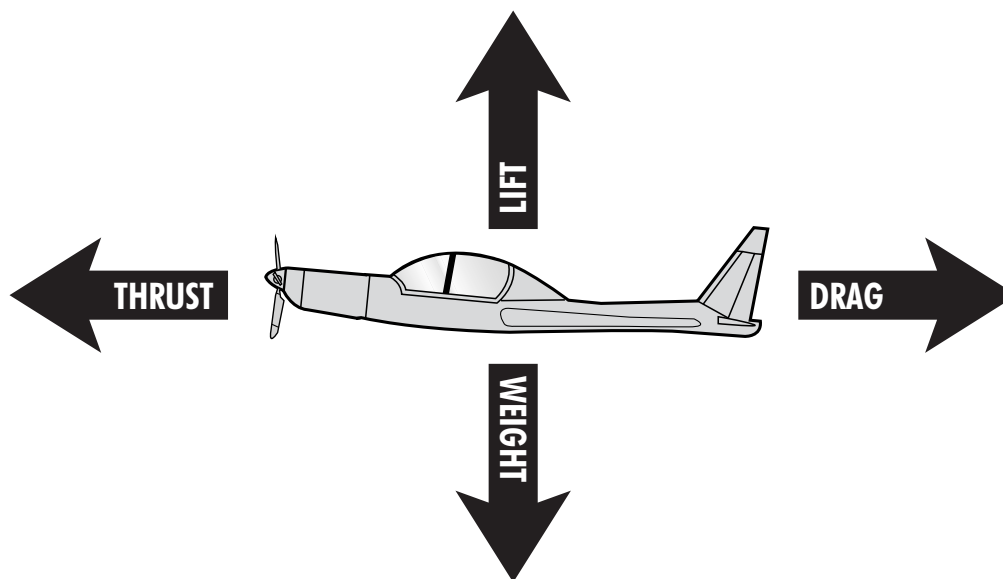
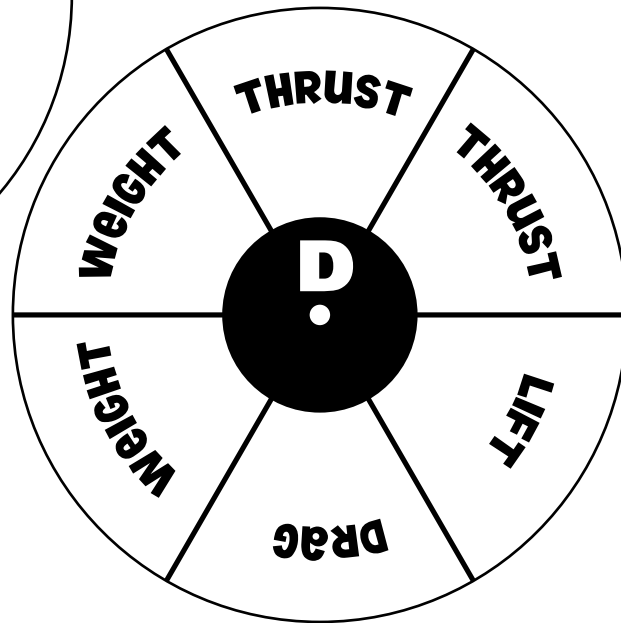
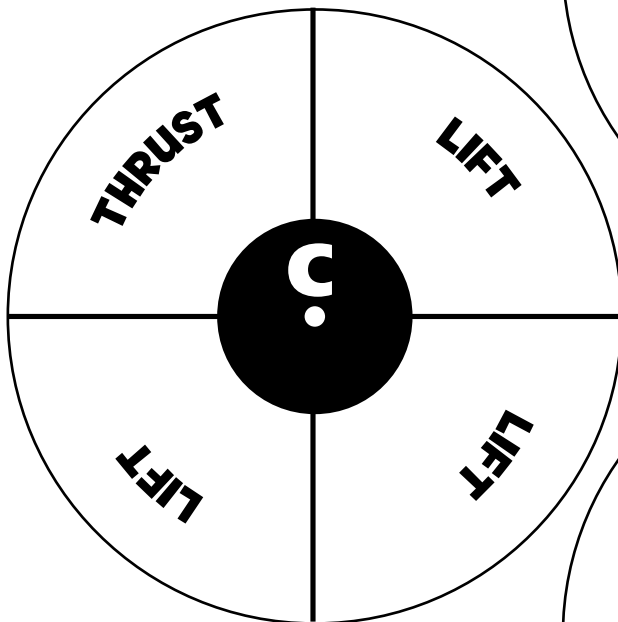
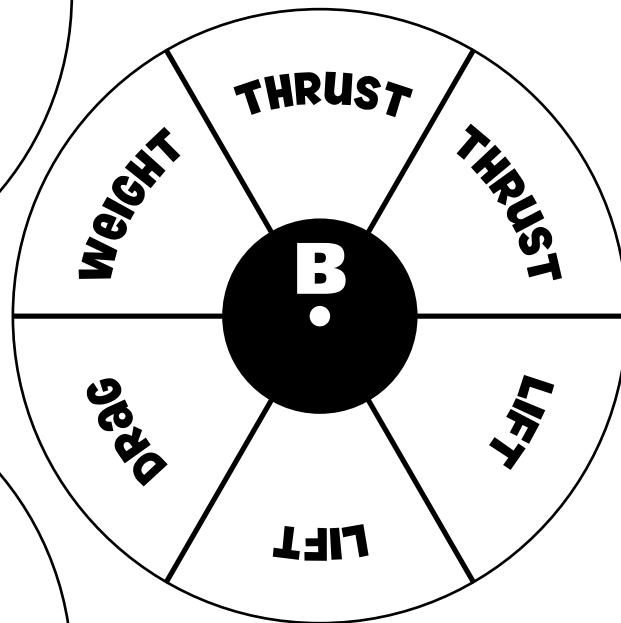
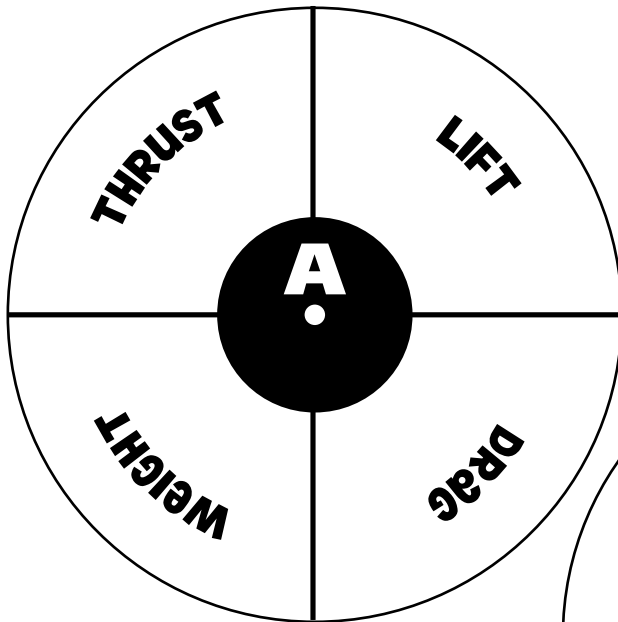
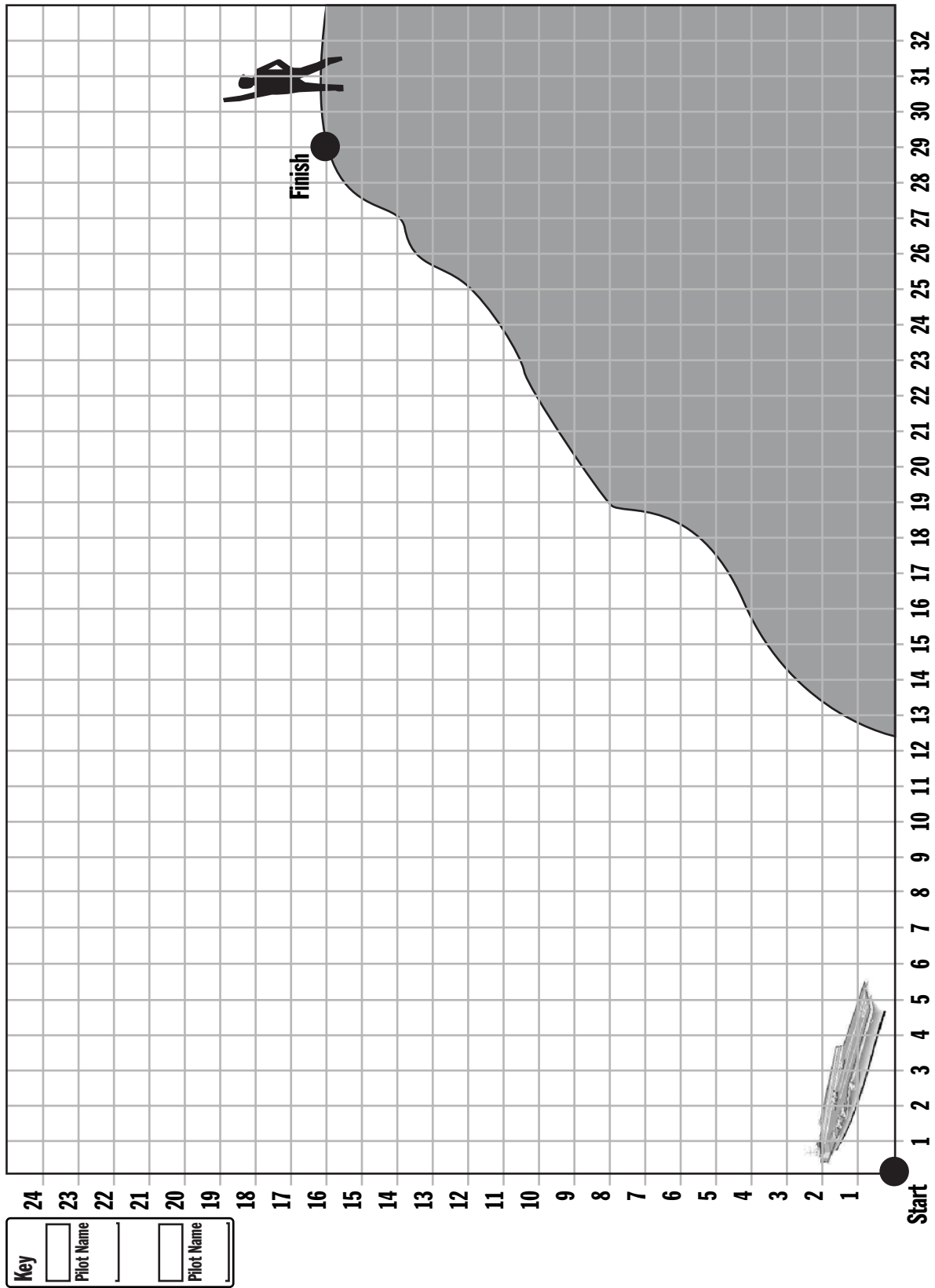

Diagram 1

# Rescue at Sea Game (continued) Spinners



# Rescue at Sea Game (continued) Gameboard



# The Egg-tra-ordinary Airplane

## Purpose

To construct a model of the plane featured in the video. To use knowledge of the four forces of flight to modify the plane.

## Procedure

1. Cut the wing from the 12-egg carton as shown, using scissors. (If razor blade or knife is used, adult help is required.)
2. Notch the center of the wing so that it fits snugly over the balsa wood, but do not glue. See diagram 1.
3. Use the ruler as a guide to bend the egg carton into a dihedral angle into the wing. Repeat twice on each half of the wing. See diagram 2. Note: If the wing cracks on the underside, rub glue into the cracks and let dry.
4. Using the template (p. 69), cut out the stabilizer and fin pattern and trace them onto the inside of the 18-egg carton top.
5. Cut out the stabilizer and fin.
6. On the side of the fuselage stick (balsa wood), mark the locations of the wing and the pin that will hold the rubber band.
7. To save weight in the tail of the model, trim off excess wood behind the pin. See diagram 3.
8. Place the propeller on the front end of the fuselage stick. If the propeller does not fit snugly, wedge small pieces of the balsa wood that you shaved off to tighten.
9. Insert pin for the rubber band.
10. Align the wings so that the front edge (leading edge) is  $\frac{1}{16}$ " higher than the back edge (trailing edge). Glue into place. Use pins to hold in place while the glue dries. Glue on tail section also using pins to hold in place. See diagram 4.
11. To test the plane, wind the rubber band 50-100 times and fly it in an open grassy area away from people.
12. If the plane pitches, yaws, or rolls, use what you have learned from the video and adjust your plane.
13. Have your own Egg-tra-ordinary plane contest!

## Conclusion

1. If the plane pitches, what should you adjust on the plane?
2. If the plane yaws, what should you adjust on the plane?
3. What provides the thrust for the plane? How?
4. Why is it important for the wing to have a dihedral angle?
5. Why is it better to use foam egg cartons instead of cardboard egg cartons?

## Extensions

1. Experiment to find the relationship between the number of turns of the rubber band and the distance flown. Make a chart and graph to show the relationship.

## Materials (per group)

top from a 12-egg carton  
 scissors  
 top from an 18-egg carton  
 needle nose pliers  
 piece of balsa wood  
 ( $\frac{3}{8}$ " X  $\frac{3}{16}$ " X  $13 \frac{1}{2}$ ")  
 glue  
 razor blade or exact  
 knife  
 propeller assembly  
 12"-14" long rubber band  
 ruler  
 pins

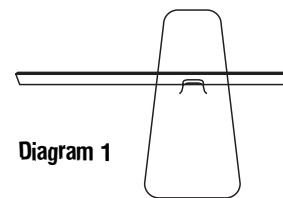

Diagram 1

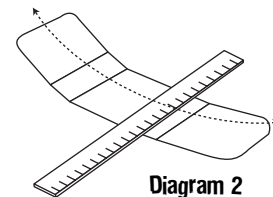

Diagram 2

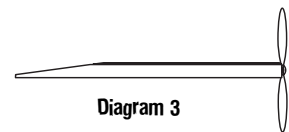

Diagram 3

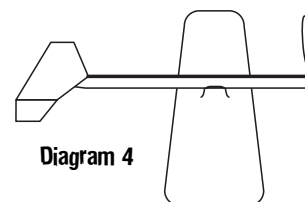
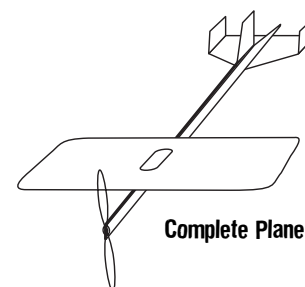
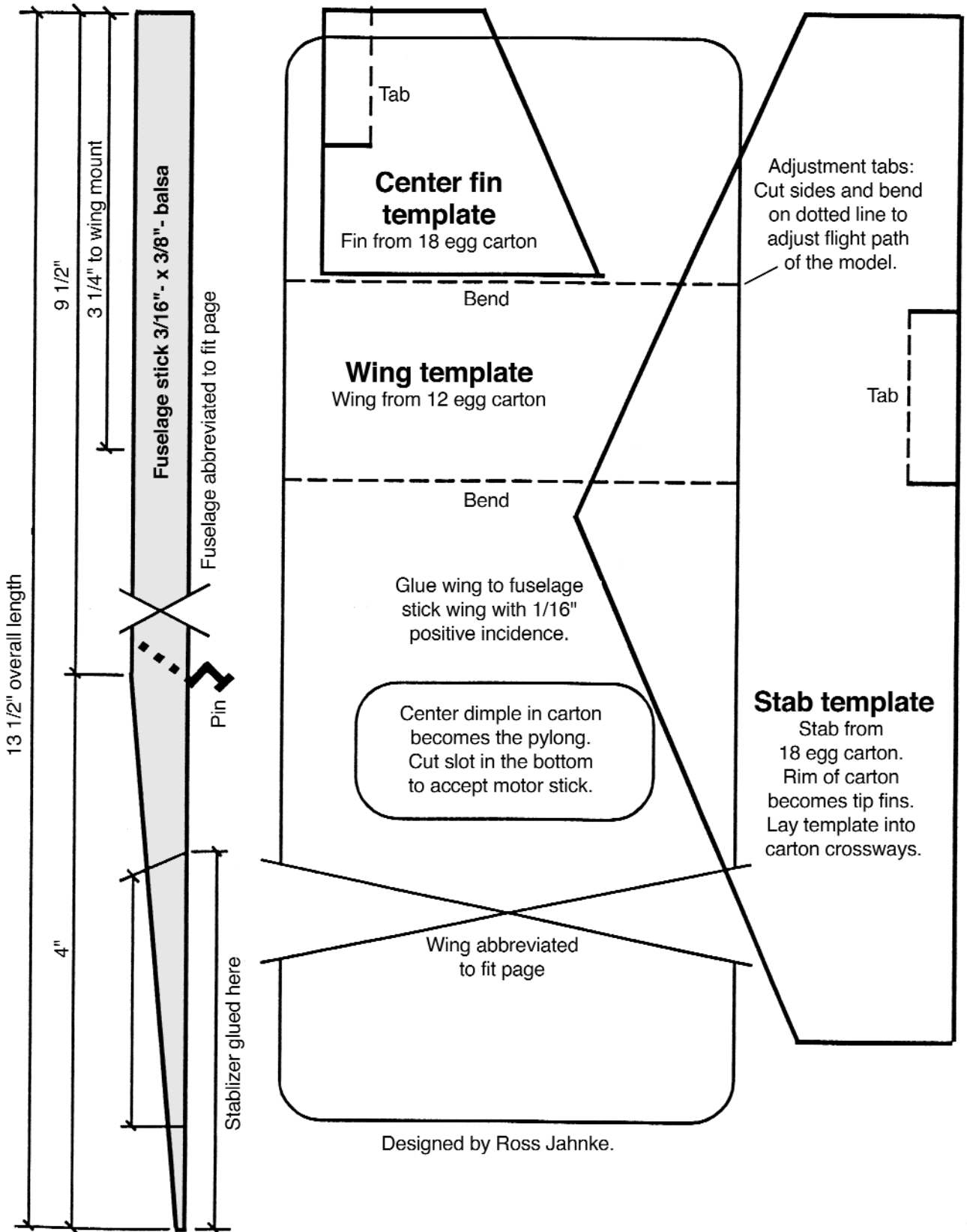

Diagram 4



Complete Plane

# The Egg-tra-ordinary Airplane (continued)



# Answer Key

## Anatomy of an Airplane

1. tail section
2. rudder
3. elevator
4. flaps
5. wing
6. fuselage
7. cockpit
8. propeller
9. aileron
10. spinner
11. engine
12. landing gear

## Flying Word Search

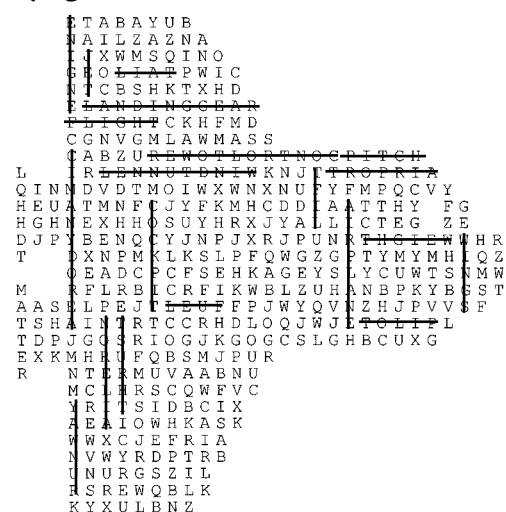

## Aileron or No Aileron

- 1.- 4. Answers will vary.
5. When the air hits the aileron, it is deflected in the direction the aileron is pointing, causing the air to slow down. The slowing down of the air creates a force that enables the plane to turn or slow down. Think of it in terms of running across a field with your arms outstretched and hitting a light post with your left arm. The force of the pole hitting your arm deflects your body in the opposite direction. The air hitting the aileron also causes the plane to go in the opposite direction, thus enabling a pilot to turn the plane. A pilot will use ailerons to turn the plane, to slow down, to control the pitch, and to land.

## Rescue at Sea Game

1. Answers will vary.
2. In the game, if you needed to move to the right, you should have chosen the spinner whose probability of “thrust” was the highest because “thrust” moved you to the right. You would not have chosen the spinner with a high probability for drag, which would turn you to the left.
3. Answers will vary.

## The Egg-tra-ordinary Plane

1. If the plane pitches up, you should bend the stabilizer tab down. If it pitches down, bend the tab up.
2. If the plane yaws to the right or left, bend the rudder tab to the opposite direction.
3. The winding of the rubber band provides the thrust for the plane. As you wind the rubber band, you are storing potential energy. When the propeller is released, the energy in the rubber band is released and causes the propeller to turn. As the propeller turns, its shape creates airflow over the propellers, creating a forward force pulling the plane through the air. As the plane is pulled through the air, the air flows over the wings, creating lift.
4. It is important for a plane to have a dihedral angle to stabilize the plane as it is turning. The angle gives the pilot more control as he/she turns the plane.
5. Foam egg cartons are lighter in weight and will therefore require less thrust to go farther.