

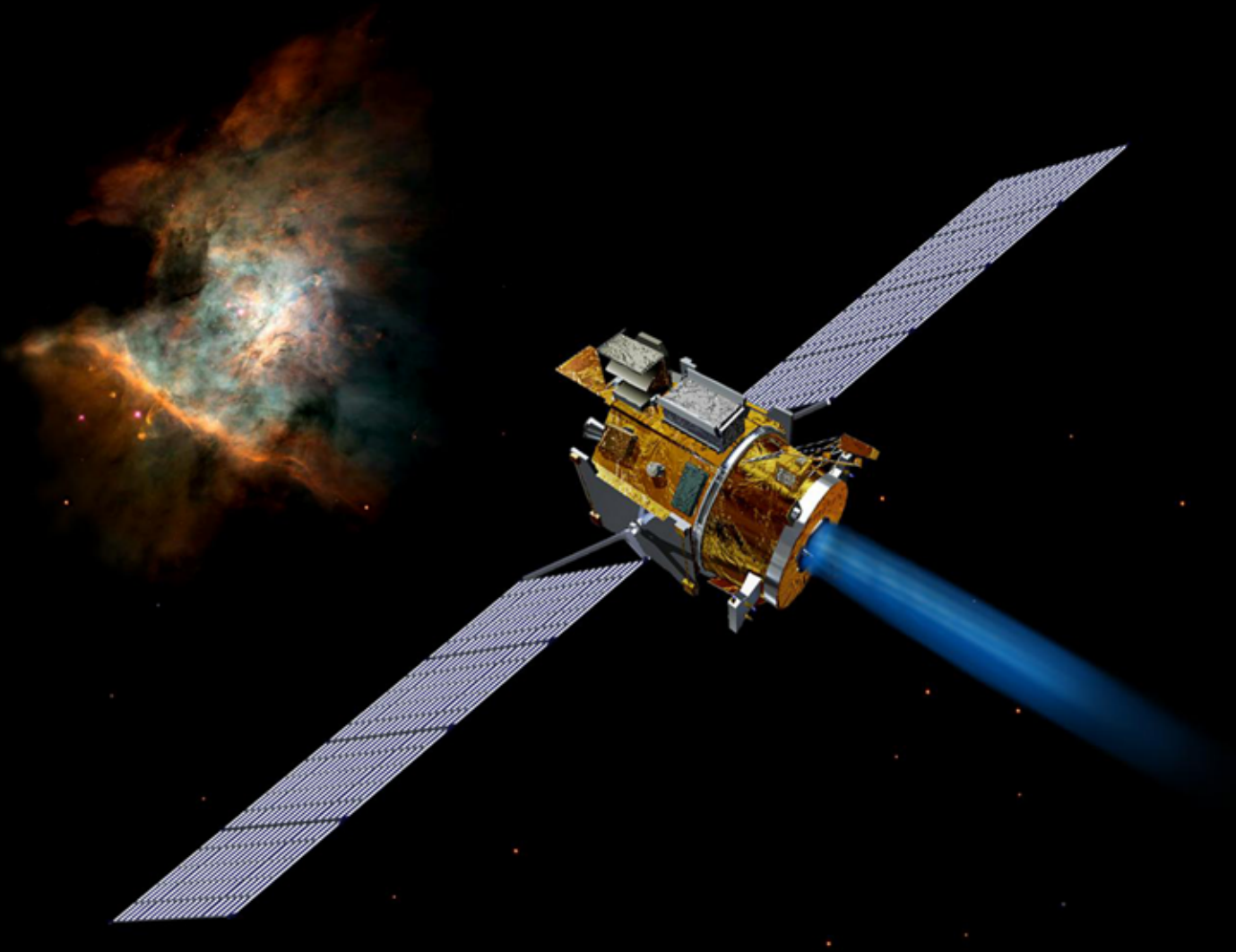

SBIR INVESTMENTS

in SPACE NAVIGATION TECHNOLOGY

2005 to 2014



SPACE COMMUNICATIONS AND NAVIGATION



*Cover photo: NASA Jet Propulsion Laboratory (JPL)
Deep Space 1 (DS1) spacecraft for asteroid and
comet flyby missions.*

FOREWORD



NASA's mission to pave the future of space exploration through innovations in science and technology is reflected in a balanced technology development and maturation program supported by all NASA Mission Directorates. Stimulating technology innovation through Small Business Innovation Research (SBIR)/Small Business Technology Transfer (STTR) programs, NASA has empowered U.S. small businesses to make significant contributions to the future of space exploration.

This technology investment portfolio highlights SBIR Phases I and II investments in radiofrequency (RF) communication technology development for the Space Operations Mission Directorate (SOMD)/Human Exploration and Operations Mission Directorate (HEOMD) from 2006 to 2014. This report summarizes technology challenges addressed and advances made by the SBIR community in RF technology. The goal of this document is to encourage program and project managers, stakeholders, and prime contractors to take advantage of these technology advancements to leverage their own efforts and to help facilitate infusion of technology advancements into future NASA projects. A description of NASA's SBIR Program can be found at www.sbir.nasa.gov.



SMALL BUSINESS
INNOVATION RESEARCH



The Small Business Innovation Research (SBIR) Program provides opportunities for small, high-technology companies to participate in Government-sponsored research and development efforts in key technology areas of interest to NASA. The SBIR Program provides significant sources of seed funding to foster technology innovation. The SBIR Phase I contracts are awarded for 6 months with funding up to \$125,000; Phase II contracts are awarded for 24 months with funding up to \$750,000.

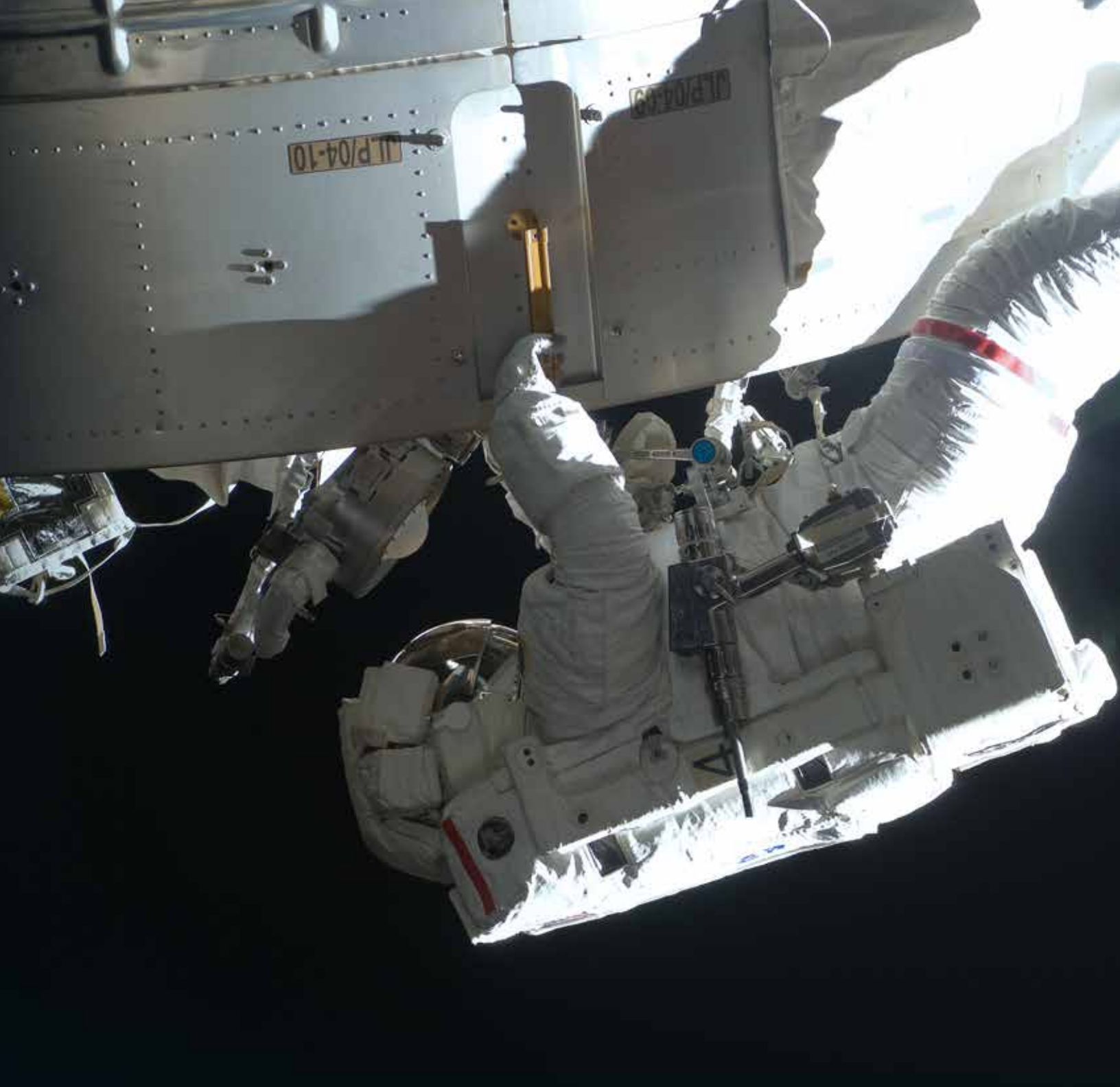

HUMAN EXPLORATION

A person wearing a space helmet is looking out a window, with bright light visible outside. The person's face is partially obscured by the helmet's visor.

The Human Exploration and Operations Mission Directorate (HEOMD) is chartered with the development of core transportation elements, key systems, and enabling technologies required for beyond-low-Earth-orbit (LEO) human exploration that will provide the foundation for the next half-century of American leadership in space exploration.

This new space exploration era starts with increasingly challenging test missions in cislunar space, including flights to the Lagrange points, followed by human missions to near-Earth asteroids (NEAs), the Moon, the moons of Mars, and Mars as part of a sustained journey of exploration in the inner solar system. HEOMD was formed in 2011 by combining the Space Operations Mission Directorate (SOMD) and the Exploration Systems Mission Directorate (ESMD) to optimize the elements, systems, and technologies of the precursor directorates to the maximum extent possible.

HEOMD mission goals include key technology developments in Space Communications and Navigation, Space Transportation, Human Research and Health Maintenance, Radiation Protection, Life Support and Habitation, High-Efficiency Space Power Systems, and Ground Processing/International Space Station (ISS) Utilization.

HEOMD looks forward to incorporating SBIR-developed technologies into current and future systems to contribute to the expansion of humanity across the solar system while providing continued cost-effective space access and operations for its customers, with a high standard of safety, reliability, and affordability.

AND OPERATIONS MISSION DIRECTORATE

SCaN: KEEPING THE

SCaN NOTIONAL INTEGRATED NETWORK ARCHITECTURE

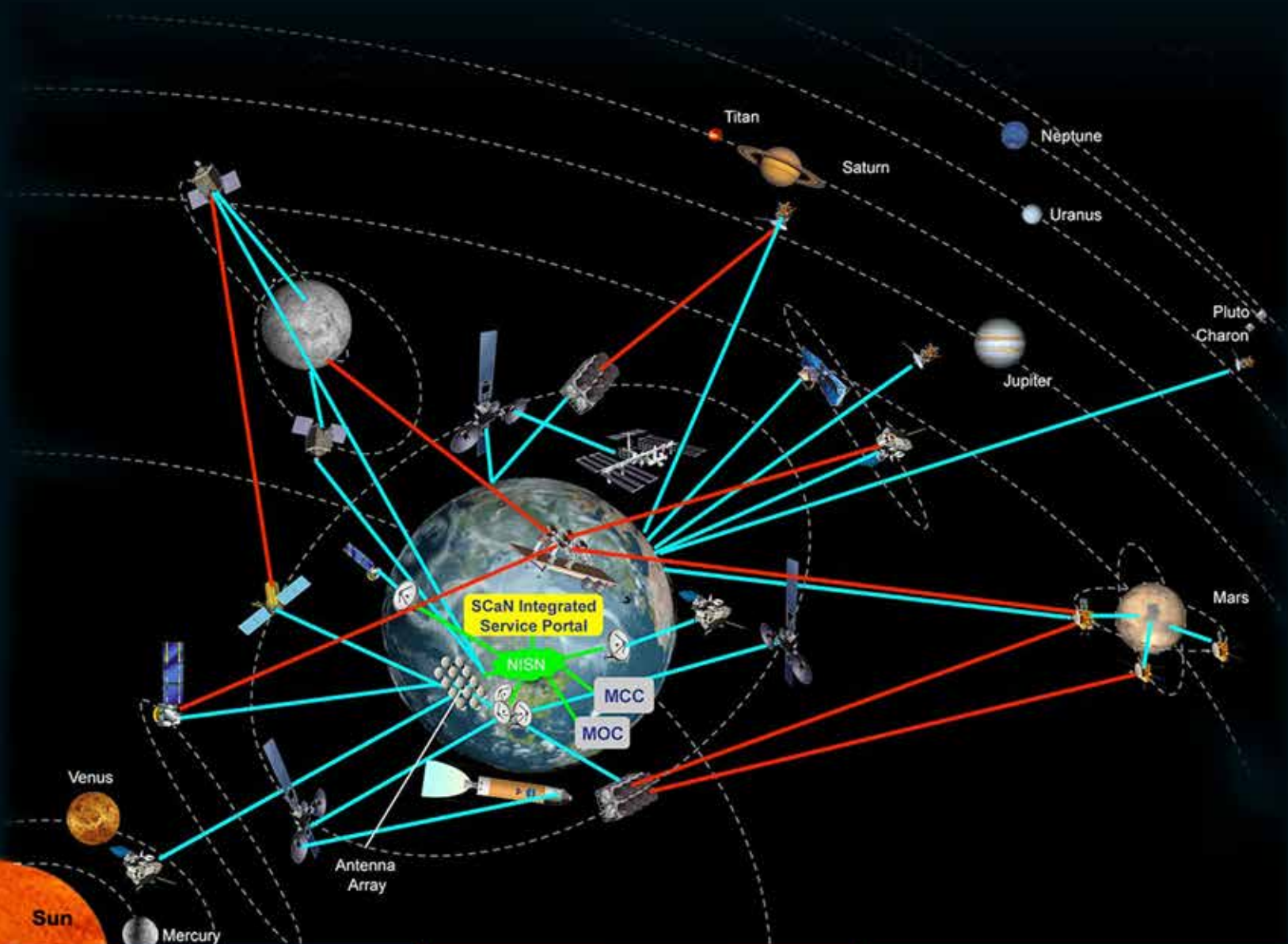

Microwave Links

Optical Links

NISN

UNIVERSE CONNECTED

PROGRAM AND TECHNOLOGY DEVELOPMENT OVERVIEW

The Space Communications and Navigation (SCaN) Program resides within HEOMD and is responsible for the development of technologies and capabilities to support all current and future NASA missions. The SCaN Program provides the communication, navigation, and mission science data transfer services that are vital to the successful operation of NASA spaceflight missions. To accomplish this, SCaN operates three networks: the Deep Space Network (DSN), the Near Earth Network (NEN), and the Space Network (SN). Combined together, the services and network assets provide capabilities that enable space exploration for over 100 NASA and non-NASA missions. SCaN also provides scheduling services to new missions through the Network Integration Management Office (NIMO) and Deep Space Network Commitment Office (DSNO).

To accomplish the above, the SCaN Program's vision is to build and maintain a scalable, integrated, and mission support infrastructure that can evolve to accommodate new and changing technologies, while providing comprehensive, robust, cost effective, and exponentially higher data rate services to enable NASA's science and exploration missions. Today NASA communication and navigation capabilities using radiofrequency (RF) technology can support spacecraft to the fringes of the solar system and beyond. The anticipated new missions for science and exploration of the universe are expected to challenge the current data rates of 300 Mbps in low Earth orbit (LEO) and of 6 Mbps at Mars to rise significantly. The SCaN Program aims to

- Develop a SCaN infrastructure capable of meeting both robotic and human exploration mission needs.
- Evolve infrastructure to provide the highest data rates feasible.
- Develop internationally interoperable data communications protocols for space missions.
- Offer communications and navigation infrastructure for lunar and Mars surfaces.
- Offer communications and navigation services to enable lunar and Mars human missions.

SCaN technology development interests include optical communications, advanced antenna technology and Earth stations, cognitive networks, access links, reprogrammable communications systems, spacecraft positioning, navigation, and timing (PNT), and communications in support of launch services. Innovative solutions to operational issues are needed in all of the areas. Emphasis is placed on size, weight, and power improvements. All SBIR technologies developed under the SCaN topic area are aligned with the SCaN Program technical directions.

This document catalogs SCaN SBIR investments in **(RF) Communication Technology** development from 2005 to 2014.

SBIR PHASE I AWARDS



CONTENTS

Space Navigation Technology	1
Navigation Technology SBIR Phase I Awards (2005 to 2014)	3
X-ray Pulsar-Based Navigation and Time Determination. <i>Microcosm, Inc.</i>	5
Optical Navigation System <i>Princeton Satellite Systems</i>	6
Synchronized Position and Hold Reorient Experimental Satellites—International Space Station (SPHERES-ISS) <i>Payload Systems Inc.</i>	7
Stable Tactical-Grade Microelectromechanical Systems (MEMS) Inertial Measurement Unit (IMU) for Spin-Stabilized Rockets <i>Milli Sensor Systems & Actuators, Inc.</i>	8
Novel GPS-Based Attitude (GPS/A) System for Launch Vehicles <i>Toyon Research Corporation</i>	9
Plenoptic Imager for Automated Surface Navigation. <i>Nanohmics, Inc.</i>	10
Lunar Surface Navigation <i>Progeny Systems</i>	11
Tracking Launch Vehicles in Interference and Jamming. <i>MARK Resources, Inc.</i>	12
A Novel Navigation Robustness and Accuracy Improvement System <i>Broadata Communications, Inc.</i>	13
Lunar Autonomous Automatic Surface Navigation System. <i>Physical Optics Corporation</i>	14
Advanced Filtering Techniques Applied to Spaceflight. <i>IST-Rolla</i>	15
Metric Tracking of Launch Vehicles <i>Toyon Research Corporation</i>	16
Continuation Methods and Non-linear/Non-Gaussian Estimation for Flight Dynamics <i>Numerica Corp.</i>	17
Multipurpose Radio Signal Generation System for Space Applications, Simulation, and Testing <i>Emergent Space Technologies, Inc.</i>	18
Low-Energy Mission Planning Toolbox <i>Princeton Satellite Systems</i>	19
Deep Space Navigation and Timing Architecture and Simulation <i>Microcosm, Inc.</i>	20
X-ray Detection and Processing Models for Spacecraft Navigation and Timing <i>Microcosm, Inc.</i>	21
Automatic Solar and Celestial Navigation on the Moon and Mars <i>Micro-Space</i>	22
Advanced Bayesian Methods for Lunar Surface Navigation <i>Autonomous Exploration Inc.</i>	23
A Lightweight, Miniature Inertial Measurement System for Position and Attitude Estimation on Dynamic Platforms <i>Impact Technologies, LLC</i>	24
Desensitized Optimal Filtering and Sensor Fusion Tool Kit. <i>Analytical Mechanics Associates, Inc.</i>	25

SBIR PHASE I AWARDS CONTINUED



CONTENTS (CONTINUED)

Lunar Localization System (LLS) <i>Utopia Compression</i>	26
Celestial X-ray Source Modeling and Catalogs for Spacecraft Navigation and Timing <i>Microcosm, Inc.</i>	27
Second-Order Kalman Filter Using Multicomplex Step Derivatives. <i>Emergent Space Technologies, Inc.</i>	28
Fault Detection and Isolation of Satellite Formations Using a Ground Station <i>SySense Inc.</i>	29
Flexible Particle Filter Navigation System for Analysis and Operations. <i>Odyssey Space Research, LLC</i>	30
MEMS Gyroscope with Interferometric Detection <i>Fine Structure Technology LLC</i>	31
Miniaturized Radiation Hardened Beam-Steerable GPS Receiver Front End <i>Tahoe RF Semiconductor, Inc.</i>	32
Innovative X-ray Star Scanner for Spin Stabilized Microsatellites <i>CrossTrac Engineering, Inc.</i>	33
Space Mission Design in the Vicinity of Small Bodies and Libration Points. <i>Physical Optics Corporation</i>	34
Parallelization of Sigma Point and Particle Filters <i>Analytical Mechanics Associates, Inc.</i>	35
Compact Optical Inertial Tracking for Launch Vehicles <i>MagiQ Technologies, Inc.</i>	36
Tracking and Data Relay Satellite System (TDRSS) Augmentation Service for Satellites (TASS)-Enhanced Near-Earth Navigation System <i>Emergent Space Technologies, Inc.</i>	37
Advanced Exoplanet Star Tracker for Orbit Self Determination <i>Keystone Aerospace</i>	38
Enhanced Path Planning, Guidance, and Estimation Algorithms for NASA's General Mission Analysis Tool (GMAT) <i>Decisive Analytics Corporation</i>	39
Advanced Spacecraft Navigation and Timing Using Celestial Gamma-Ray Sources <i>ASTER Labs, Inc.</i>	40
Accurate Timekeeping With an Ensemble of Clocks <i>Perichoro LLC</i>	41
Advanced Techniques for Non-Collocated Fault Detection of Satellite Formation <i>SySense, Inc.</i>	42
An Interactive Visual Analytics Tool for NASA's General Mission Analysis Tool (GMAT). <i>Decisive Analytics Corporation</i>	43
Integrated Spacecraft Navigation and Communication Using Radio, Optical, and X-rays. <i>ASTER Labs, Inc.</i>	44
Interferometric Star Tracker for High-Precision Pointing. <i>Optical Physics Company</i>	45
Parallel Nonlinear Optimization for Astrodynamic Navigation <i>CU Aerospace, LLC</i>	46
Parallel Enhancements of the General Mission Analysis Tool (GMAT) <i>Thinking Systems, Inc.</i>	47

SBIR PHASE II AWARDS



CONTENTS

Navigation Technology SBIR Phase II Awards (2005 to 2012)	49
X-ray Pulsar-Based Navigation and Time Determination. <i>Microcosm, Inc.</i>	50
Optical Navigation System <i>Princeton Satellite Systems</i>	51
Novel GPS-Based Attitude (GPS/A) System for Launch Vehicles <i>Toyon Research Corporation</i>	52
Lunar Surface Navigation <i>Progeny Systems</i>	53
Tracking Launch Vehicles in Interference and Jamming. <i>MARK Resources, Inc.</i>	54
Advanced Filtering Techniques Applied to Spaceflight. <i>IST-Rolla</i>	55
Continuation Methods and Non-linear/Non-Gaussian Estimation for Flight Dynamics <i>Numerica Corp.</i>	56
Multipurpose Radio Signal Generation System for Space Applications, Simulation, and Testing <i>Emergent Space Technologies, Inc.</i>	57
Deep Space Navigation and Timing Architecture and Simulation <i>Microcosm, Inc.</i>	58
X-ray Detection and Processing Models For Spacecraft Navigation and Timing <i>Microcosm, Inc.</i>	59
Advanced Bayesian Methods for Lunar Surface Navigation <i>Autonomous Exploration Inc.</i>	60
A Lightweight, Miniature Inertial Measurement System for Position and Attitude Estimation on Dynamic Platforms <i>Impact Technologies, LLC</i>	61
Desensitized Optimal Filtering and Sensor Fusion Tool Kit. <i>Analytical Mechanics Associates, Inc.</i>	62
Microelectromechanical Systems (MEMS) Gyroscope With Interferometric Detection <i>Fine Structure Technology LLC</i>	63
Miniaturized Radiation Hardened Beam-Steerable GPS Receiver Front End <i>Tahoe RF Semiconductor, Inc.</i>	64
Tracking and Data Relay Satellite System (TDRSS) Augmentation Service for Satellites (TASS)-Enhanced Near-Earth Navigation System <i>Emergent Space Technologies, Inc.</i>	65
Enhanced Path Planning, Guidance, and Estimation Algorithms for NASA's General Mission Analysis Tool (GMAT) <i>Decisive Analytics Corporation</i>	66
Framework for the Design and Implementation of Fault Detection and Isolation <i>SySense, Inc.</i>	67
Company Names.	69
Points of Contact	70

SPACE NAVIGATION TECHNOLOGY

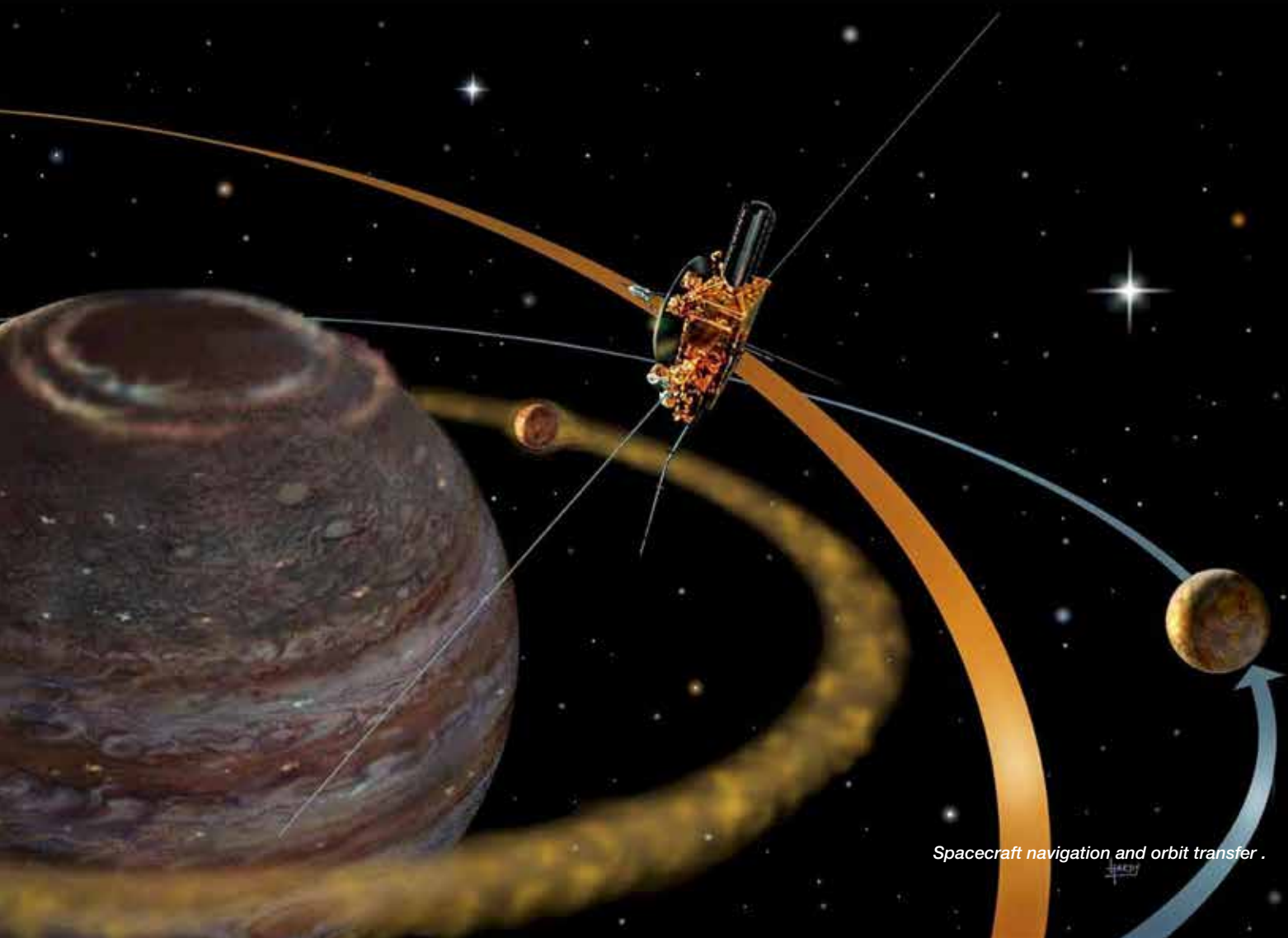

Spacecraft navigation and orbit transfer .

NASA is investing in the development of software tools, system concepts, and devices to enhance capabilities for providing position, attitude, and velocity of its spacecraft as well as improve their navigation, guidance, and control functions. Interest includes software tools, ground facilities, system concepts, and onboard devices in support of its deep space missions. Proposals can address any mission phase from design, development to operation for either near-Earth or interplanetary missions. Specific application needs are:

Software that analyzes spacecraft sensor or tracking data. Algorithms for flight dynamics GNC and technologies leading to the replacement of Goddard Trajectory Determination System (GTDS), or leverage NASA General Mission Analysis Tool, GPS-Inferred Positioning System and Orbit Analysis Simulation Software, Optimal Trajectories by Implicit Simulation are encouraged. NASA's primary needs are in the following areas:

- Optimal control theory application to spaceflight guidance and control systems
- Numerical methods for robust targeting and nonlinear constrained optimization
- Addition of novel guidance, navigation, and control improvements to existing NASA software via NASA Open Source Agreements or by the licensed proposer
- Interface and workflow improvements, tool modularization and , APIs and cross-platform interfaces for available software via NASA Open Source Agreements
- Applications of cutting-edge estimation techniques to spaceflight navigation
- Applications of estimation techniques that have an expanded state vector (beyond position, velocity, and/or attitude components) or that combine multiple sensor measurements to improve overall system accuracy
- Applications of advanced dynamical theories to space mission design and analysis, in the context of unstable orbital trajectories in the vicinity of small bodies and libration points
- Advanced celestial navigation techniques including devices and systems in support of deep space, planetary missions.

System concepts should support significant advances in independence from Earth supervision and the ability to operate effectively in the absence of Earth-based or planetary relay spacecraft transmission. Systems that operate in the complete absence of human intervention or Earth-based transmissions are preferred. Solutions should meet these objectives while minimizing spacecraft power, mass and volume burden. User spacecraft impact should include assessments of mass, power, and thermal impact on mission spacecraft. Of particular interest are concepts supporting high-rate optical communications terminals pointing to Earth terminals without relying on optical uplinks or beacons for achieving proper pointing of the communication beam. However, concepts that are capable of supporting planetary missions of any type are of interest. Proposals that include repurposing of advanced sensors contemplated for future deep space missions such as x-ray telescopes are preferred. In addition to positioning, attitude estimation, orbit determination, and guidance, navigation and control, of particular interest is the following focus topics in deep space celestial navigation:

- Time and frequency keeping and dissemination
- Advanced methods and sensors for optical/infrared detection of star fields
- Advanced methods and sensors detecting RF and x-ray pulsars
- Methods to process celestial observations to perform Orbit Determination (OD) and precision attitude estimation

Phase I should demonstrate technical feasibility, with preliminary software to be delivered for NASA testing, as well as a plan towards Phase II integration. Proposals that develop hardware, a prototype delivery under the Phase I is preferred, but not necessary.

With the exception for heritage software modifications, Phase II new technology efforts shall deliver components at the technology readiness level (TRL) 5 to 6 level with mature algorithms and software components complete and preliminary integration and testing in an operational environment. For efforts that improve existing NASA software tools, the deliverable TRL shall be consistent with the heritage software TRL. Final software, test plans, test results, and documentation shall be delivered to NASA.

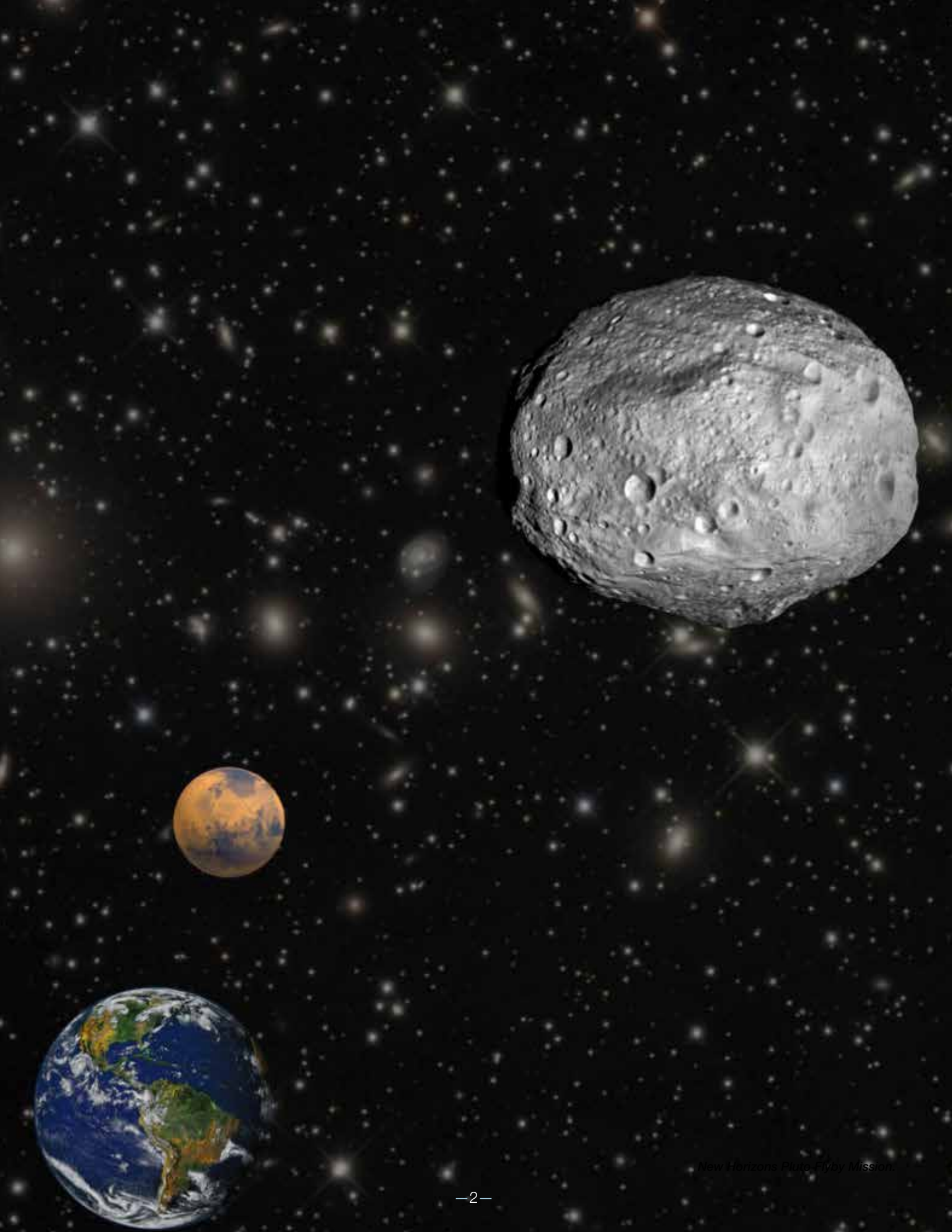



NAVIGATION TECHNOLOGY SBIR PHASE I AWARDS

2005 TO 2014

NASA Dawn spacecraft to dwarf planets Ceres and Vesta.



NASA Deep Space 1 Flyby mission to Comet Borrelly.

X-RAY PULSAR-BASED NAVIGATION AND TIME DETERMINATION

Microcosm, Inc.

2005 Phase I
01.02-9013

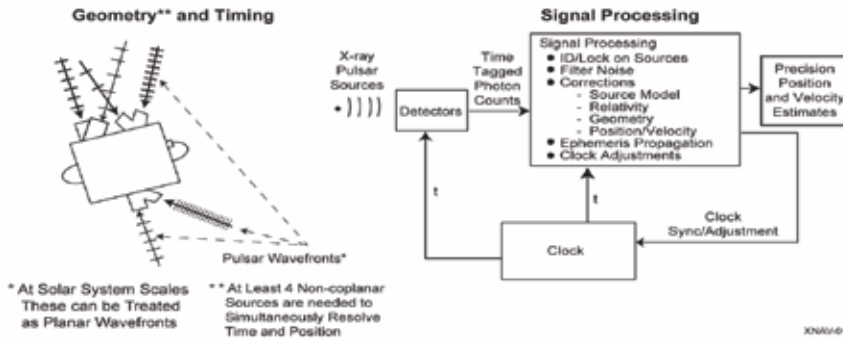

Pulsars can be thought of as a natural GPS-like signal source. With source timing models, adequate collection time and collection area, signals can be filtered to produce very accurate time and position estimates for spacecraft in Earth orbit or interplanetary space.

Technical Objectives

- Develop a source catalog and assess detector technologies
- Review potential NASA applications and develop use cases
- Develop detailed requirements from most promising use cases
- Review systems engineering and key systems trades for each use case
- Develop navigation/timing error budgets for each use case
- Develop a cost/benefit assessment framework and carry out a preliminary assessment
- Develop block diagrams for the navigation/timing algorithms for the selected use case(s)

Technical Objectives

- Task 1—Source Characterization and Detectors
- Task 2—Applications and Use Cases
- Task 3—Systems Engineering
- Task 4—Algorithm Definition
- Task 5—Navigation/Timing Error Budgets
- Task 6—Benefits Assessment

NASA Applications

XNAV is principally applicable to NASA interplanetary missions—regions beyond the range of GPS which rely on DSN for navigation. It provides autonomous navigation throughout the solar system. It can augment the DSN by providing accurate time synchronization, and position and velocity components normal to the line-of-sight to Earth, both of which will enable faster and more accurate navigation solutions. It could enable accurate, autonomous GPS-like navigation for surface vehicles and orbiters at Mars or other planets. XNAV can enable spatially and temporally coordinated measurements over solar system scale distances, enabling or enhancing interferometer missions.

Non-NASA Applications

Non-NASA applications are likely to be for Department of Defense (DoD) missions. Specific applications include navigation outside of GPS range, backup navigation in the event of GPS denial, and development of a super-synchronous navigation and time distribution service. XNAV could also prove viable for autonomous navigation and station-keeping for geostationary Earth orbit (GEO) satellites.

Identification and Significance of Innovation x-ray pulsar-based navigation and timing (XNAV) holds great promise for NASA because it is an enabling technology for fully autonomous interplanetary navigation and would provide significant mission enhancements as an adjunct to the Deep Space Network (DSN) and ground-based navigation analysis. XNAV uses observations of the x-ray emissions of highly stable, rotation-powered, millisecond pulsars as a kind of “natural GPS” signal. Accurate pulse time-of-arrival estimates from four or more noncoplanar sources allows simultaneous determination of both position and time autonomously anywhere in the solar system.

This SBIR project will position NASA to take full advantage of the emergent XNAV technology, which is currently being investigated by the Defense Advanced Research Projects Agency (DARPA). It has the potential to greatly enhance system autonomy while driving down DSN operations and infrastructure costs. This project is focused on assessment of the potential utility of XNAV for NASA missions and development of the algorithms, hardware requirements, and performance simulations for NASA navigation and time determination applications.

OPTICAL NAVIGATION SYSTEM

Princeton Satellite Systems

2006 Phase I
01.02-8582

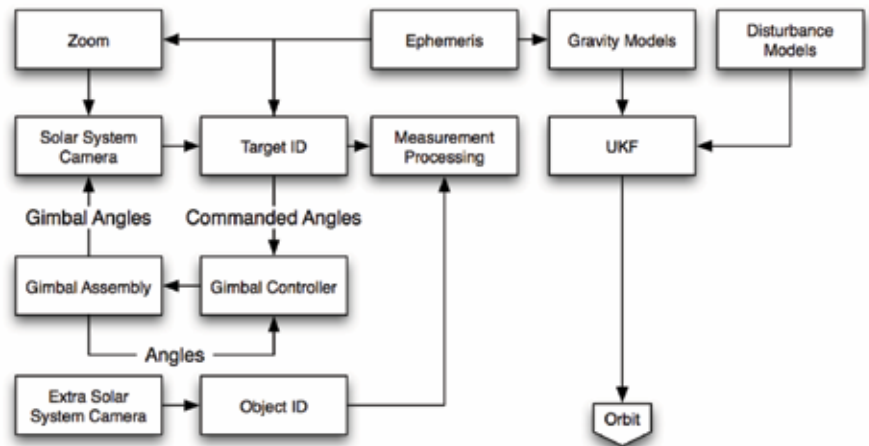

Optical navigation system.

Identification and Significance of Innovation

This proposal is for a flexible navigation system for deep space operations that does not require GPS measurements. The navigation solution is computed using an Unscented Kalman Filter that can accept any combination of range, planet chordwidth, and angle measurements using any celestial object. The UKF employs a full nonlinear dynamical model of the orbit including gravity models and disturbance models. The filter will estimate both states and parameters. The integrated system employs a new multibandwidth optical sensor that can select the optimal wavelength for planetary chords. The extra solar system body sensor will employ band-limiting imaging with the band selected to maximize reliable autonomous object identification.

Technical Objectives

- Demonstrate the autonomous navigation system in simulation
- Produce a conceptual design of the solar system body camera
- Produce a conceptual design of the extra solar system body sensor

Work Plan

Produce preliminary designs of the extra solar system and solar system sensors employing novel image processing techniques.

NASA Applications

The navigation system will be applicable to any manned or unmanned spacecraft including commercial, military, and scientific missions. The Unscented Kalman Filter algorithm can be applied to any estimation problem and could be used for many navigation products

SYNCHRONIZED POSITION AND HOLD REORIENT EXPERIMENTAL SATELLITES—INTERNATIONAL SPACE STATION (SPHERES—ISS)

Payload Systems Inc.

2006 Phase I
01.02-9562

A shared lab facility for software validation:

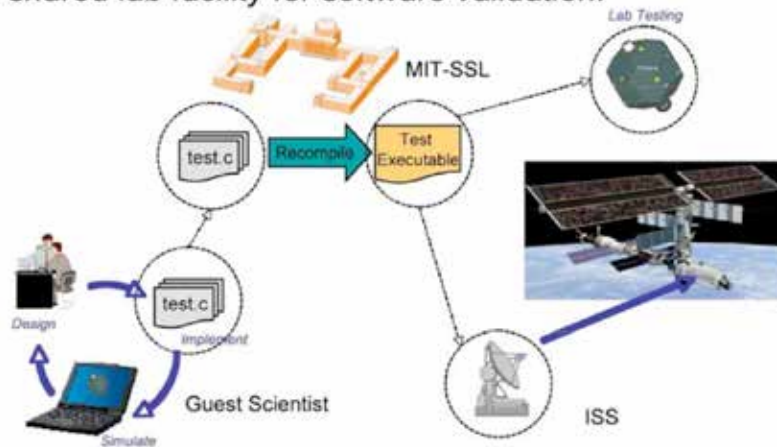

Technical Objectives

- Implement and test the Pluribus algorithm on the SPHERES ground testbed at MIT, and then in orbit on the SPHERES testbed on ISS.
- Demonstrate the reduction in control complexity provided by Pluribus
- Quantify the reduction in control complexity as the number of vehicles is increased
- Examine how the implementation of Pluribus is impacted by the type of maneuver being performed

Work Plan

- Task 1—Requirements development and compatibility assessment
- Task 2—1-g (ground) implementation on SPHERES
- Task 3—0-g (flight) implementation on SPHERES
- Task 4—Phase 2 planning
- Task 5—Reporting

NASA Applications

- Formation flight spacecraft systems
- Other missions involving cooperative multivehicle operations

Non-NASA Applications

- Department of Defense formation flight and proximity operations missions
- International space programs involving cooperative multivehicle operations

Identification and Significance of Innovation
Payload Systems, Inc., and the MIT Space Systems Laboratory propose an innovative research program entitled “SPHERES—ISS” that uses their satellite formation flight laboratory (SPHERES), currently operating aboard the International Space Station, to refine and validate NASA Goddard Space Flight Center’s Pluribus algorithms.

STABLE TACTICAL GRADE MICROELECTROMECHANICAL (MEMS) INERTIAL MEASUREMENT UNIT (IMU) FOR SPIN-STABILIZED ROCKETS

Milli Sensor Systems & Actuators, Inc.

2007 Phase I
01.03-9070

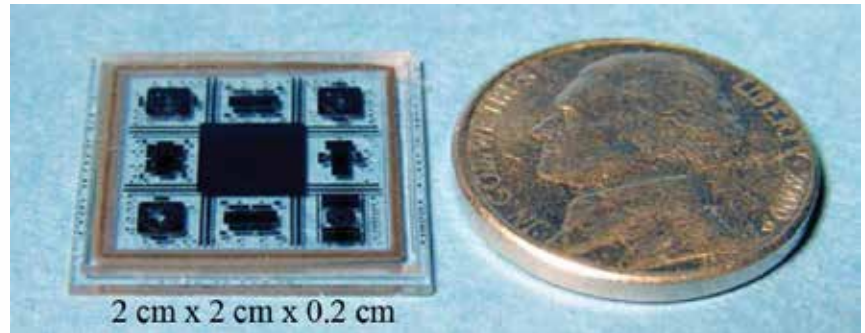

Single-Chip Vacuum-Packaged MEMS IMU Sensor

- Enables integration of IMU sensor chip, FPGA, GPS chip set, Mission Computer into a “system in a package” for smart GN&C.
- Lowest cost, smallest size, embeddable MEMS IMU.

Identification and Significance of Innovation

- Unique gyro designs with low cross-axis sensitivity, precision alignment of instruments on chip, bias stabilization techniques, and rugged substrate permit tactical grade performance under high spin.
- MEMS IMU Sensor Chip, field-programmable gate array (FPGA) to operate IMU instruments, high-density package in development in Missile Defense Army (MDA) SBIR programs.
- Systems engineers can access raw signals from sensors, implement their own proprietary algorithms to process signals, and integrate with output of other sensors.
- Path to Navigation-Grade Performance in MEMS instruments.

Expected technology readiness level (TRL) range at the end of contract

- 4 to 5

Technical Objectives

- Demonstrate MSSA IMU operation under spin rates >7 rps
- Demonstrate techniques for bias stabilization
- Use signals from instruments to determine pitch and yaw axes

Work Plan

- Develop the algorithm to operate IMU under rocket spin
- Utilize existing IMU chips, modify test station for high spin rates
- Evaluate gyroscope and accelerometer under high spin rates
- Demonstrate algorithms to determine pitch and yaw
- Feasibility assessment

NASA and Non-NASA Applications

- Tactical-grade MEMS IMUs for spin-stabilized sounding rockets, coupled with GPS receivers, for GPS/INS Metric Tracking, Autonomous Flight Safety Systems, Attitude Determination
- “Plug and play” high-performance, low-weight MEMS IMUs for “Robust On-Board GN&C Avionics” and Range Safety solutions for NanoSat Launch Vehicles/Low-Cost Small Spacecraft (topic S4.01)
- Highly integrated modules with GPS, IMUs, communications, processors, and other sensors/seekers for “Integrated Avionics Systems for Small Scale Remotely Operated Vehicles” (topic A1.09)
- MEMS IMUs for spinning munitions and small missiles; to stabilize small UAVs and UAV-borne sensors and cameras; low-cost MEMS IMUs for air, land, and water vehicle navigation, with or without GPS-aiding; “Personal Navigation” for warfighters and “first responders”; Precision motion tracking for portable/wearable systems (helmets and headsets), and for bore-hole measurement

NOVEL GPS-BASED ATTITUDE (GPS/A) SYSTEM FOR LAUNCH VEHICLES

Toyon Research Corporation

2007 Phase I
01.03-9524

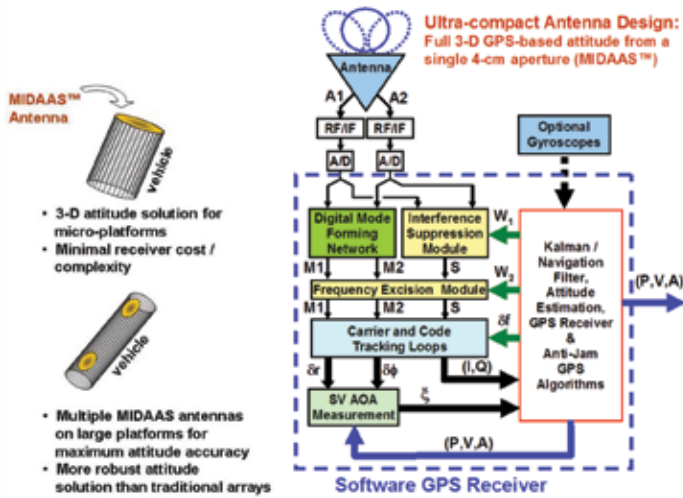

Technical Objectives and Work Plan

- Design single- and multi-MIDAAS antenna-capable RF front end
- Design single- and multi-MIDAAS antenna-capable GPS/A processor
- Modify GPS/A algorithms for use with single- and multi-MIDAAS antenna systems
- Determine (gyro-less) MIDAAS sensor accuracy for single- and multi-antenna configurations
- Determine MIDAAS accuracy with IMU-aiding for single- and multi-antenna configurations

NASA and Non-NASA Applications

- GPS-based attitude determination for launch vehicles
- Zero-drift attitude system for unmanned/micro air vehicles (UAVs and MAVs)
- Navigation aid for hand-held GPS receivers and land robots
- Orienting device for recreational and virtual reality systems

Identification and Significance of Innovation

- MIDAAS is Miniature Integrated Direction-finding Attitude-determining Anti-jam System
- Innovative antenna/receiver design reduces size and complexity of three-dimensional 3-D GPS-based attitude system
- Dual-mode antenna allows 3-D attitude with only two radiofrequency (RF) channels
- Open-source GPS software-defined receiver (SDR) minimizes development cost and time and long-term system upgrade costs
- Fully active anti-jam capability in each MIDAAS unit
- Tactical-grade accuracy with commercial-grade components and cost

PLENOPTIC IMAGER FOR AUTOMATED SURFACE NAVIGATION

Nanohmics, Inc.

2008 Phase I
04.03-8459

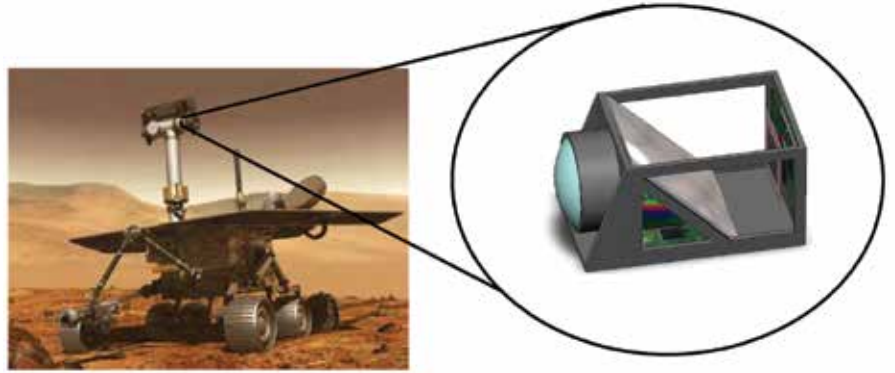

Identification and Significance of Innovation
Nanohmics proposes to design an electro-optical imaging device capable of autonomously determining the range to objects in a scene without the use of active emitters or multiple apertures. The novel, automated, low-power imaging system is based on a plenoptic camera design, and will be simple to implement, providing the range to selected objects in the field of view. Nanohmics will work towards presenting a three-dimensional 3-D map of the field-of-view plus range—to be used at a later time to interface with the autonomous vehicle for navigation and obstacle avoidance. The system will be designed so that it is inexpensive, easy to integrate with existing/planned planetary rovers, rugged, and low in maintenance.

Technical Objectives

The specific aims of the project include the development of the following technologies:

- Design of a plenoptic optical system that attaches to an autonomous vehicle to assist with navigation and optical avoidance
- Algorithms to determine range to objects within a field in real-time using a single-aperture, passive system
- Customized structure from motion algorithms to optimize range to objects at longer distances from the vehicle
- Rapid commercialization of NASA-sponsored technology

NASA and Non-NASA Applications

- Machine vision and robotics
- 3-D remote viewing, measurement, and retrieval for sewer/pipe inspection, ventilation, and boreholes
- 3-D precision part inspection and reverse engineering for rapid introduction into modeling tools
- Geological and construction survey of terrain
- Gun-sight passive optical ranging



Technical Objectives

- Fully develop our notional concept of a high-precision, scalable lunar navigation system.

Work Plan

- Architecture Definition
 - Topology
 - Communications Protocols
 - Field Stations (Mobile and Portable Stationary)
- Navigation System Operational Description
 - Timing
 - Position Estimation Algorithm
 - Sensitivity Analysis Relating Timing Errors to two-dimensional and three-dimensional
 - Positional Estimation Errors
- **Node Design**
 - Power/Cooling Requirements including power source
 - Power Management
 - Duty Cycle Study
 - Environmental Constraints
 - Electronics
 - Antenna Design
 - Mast Mechanical Design

NASA and Non-NASA Applications

- Primarily in planetary habitation, exploration, and mining but also have applications in down range tracking systems for lunar, terrestrial, or Mars launch and reentry tracking
- Modernization of aging international LORAN infrastructure with a lower-power more-accurate digital solution
- Modernization of domestic and foreign air traffic control systems with a highly precise and reliable air traffic and runway monitoring system

Identification and Significance of Innovation

- Establishes a high-precision navigation system that can scale seamlessly to any size, allows any number of mobile or portable/temporary nodes within the network, and applies state-of-the-art ultra-low power electronics to optimize battery use and support size, weight, and power (SWaP) goals
- Applies established technologies to provide an innovative solution to lunar navigation while naturally supporting data and voice communications on the same network.
- Provides a precise and reliable navigation backbone to support traverse-path planning systems and other mapping applications and establishes a core infrastructure for long-term occupation.
- The proposed tower network provides the least technological risk, employing proven physics and navigational measurement techniques coupled with recent advances in precision network time synchronization.

Expected technology readiness level (TRL) range at the end of contract (1–9)

- 4

TRACKING LAUNCH VEHICLES IN INTERFERENCE AND JAMMING

MARK Resources, Inc.

2008 Phase I
04.01-9264



Identification and Significance of Innovation

MARK Resources proposes to develop a method for combining a set of distributed FRPAs into a network that provides high GPS anti-jam/interference capability. The individual antennas need not be precisely located relative to one another. The proposed system is compatible with any GPS antennas and receiver hardware, operates on the C/A code, and has a small processing load. It will make GPS metric tracking robust against jamming and interference, hence, effective for range safety.

Expected technology readiness level (TRL) range at the end of contract (1–9)

- 2 to 3

Technical Objectives

Demonstrate the feasibility of using several distributed FRPAs to suppress interference and jamming and to provide sufficiently accurate and timely position measurements from the C/A code for range safety, antenna pointing, docking maneuvers, and attitude determination.

Work Plan

- Simulate signals and interference
- Develop algorithms
 - Jammer suppression, antenna selection, and GPS processing
- Automate algorithms
- Demonstrate performance
- Estimate implementation requirements

NASA Applications

GPS metric tracking of Ares and other launch vehicles; autonomous flight safety system; and space-based range certification and demonstration project

Non-NASA Applications

Common Range Integrated Instrumentation System; Small Diameter Bomb; A-160 Humming Bird helicopter; High Altitude Long Endurance (HALE) aircraft; and Scan Eagle UAV

A NOVEL NAVIGATION ROBUSTNESS AND ACCURACY IMPROVEMENT SYSTEM

Broadata Communications, Inc.

2008 Phase I
04.01-9665

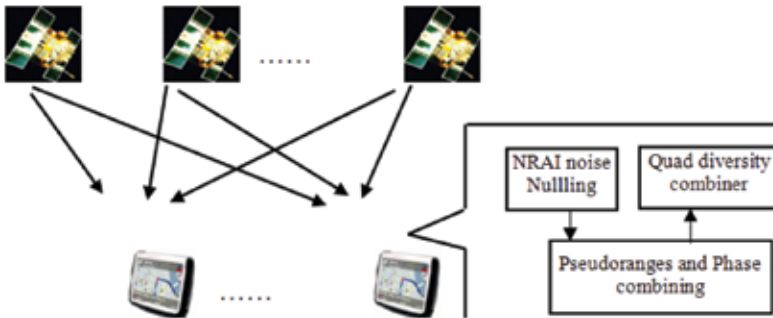

The NRAI system takes the signals of different antennas, or GPS receivers, as input and passes them to the NRAI signal detection and noise nulling component. The Broadata Communications, Inc. (BCI) intelligent multiple input multiple output (MIMO) nulling algorithm performs a signal detection and nulling scheme based on modified successive ordered signal cancellation. The NRAI system then use a recursive LS approach based on the triple-differencing technique to combine the pseudoranges and phases of noise mitigated L1 C/A signals to eliminate errors and ambiguities in the observables, including phase combiners and pseudoranges. The smoothed pseudorange data from every antenna is then combined in a quad diversity combiner to further reduce noise interference and to improve navigation accuracy.

Technical Objectives

- Exploration and evaluation of various NRAI prototype system designs
- Design of algorithms, development, and comparison of the NRAI system using simulations
- Demonstration of the feasibility of the NRAI system
- Formalization of a full-scale Phase II work plan with Phase III commercialization applicability

Work Plan

- Identify system requirements and environment
- Design NRAI system architecture and software
- Demonstrate a first prototype release
- Formalize Phase II Plan and explore commercialization
- Prepare and submit final report

NASA Applications

NASA applications include high-accuracy antenna pointing, docking maneuvers, and attitude determination. Most NASA navigation systems will greatly benefit from the development of BCI's high-accuracy NRAI system by enhancing the antispoofing capability and positioning accuracy of L1 C/A code-based navigation.

Non-NASA Applications

There are various non-NASA applications, including robust and high-accuracy navigation in aircraft industry and commercial automotive industry systems. Examples include enabling safe semiautonomous driving and providing autonomous robotic navigation.

Identification and Significance of Innovation

- L1 C/A codes used by GPSs do not require classified decryption and can be directly accessed by civilians. However, their accuracy, within 30 m and 1 m/s, does not meet the range of safety needs for certain applications, such as antenna pointing, docking maneuvers, and attitude determination. Unlike P code, CA code also offers little protection against deliberately transmitted false signals, or spoofing.
- NASA seeks innovations to improve navigation robustness against the interfering signals received by GPS receivers and to increase the accuracy of L1 C/A navigation, but with an open design that can work on any GPS receiver.
- The proposed NRAI system, an innovative noise nulling and observable combiner technology, nullifies the interference noise from the GPS receiver data and eliminates errors and initial cycle ambiguity in pseudorange measurement and carrier phase ambiguity. It offers a 4 to 6 dB SNR improvement factor over other techniques and increases the accuracy of the L1 C/A navigation to less than 1 m and 1 cm/s, using commercial-off-the-shelf (COTS) chips and NRAI algorithms.
- The NRAI system is based on an innovative multiple-antenna detection technique. It uses a successive decision feedback-based noise cancellation to iteratively estimate the signal and noise for each antenna, which allows for fast and reliable detection of signal and interference noise. The NRAI system also uses a high-performance triple-differencing-based observable combiner and fast quad diversity combiner technology to maximize measurement accuracy in navigation.

LUNAR AUTONOMOUS AUTOMATIC SURFACE NAVIGATION SYSTEM

Physical Optics Corporation

2008 Phase I
04.03-9713

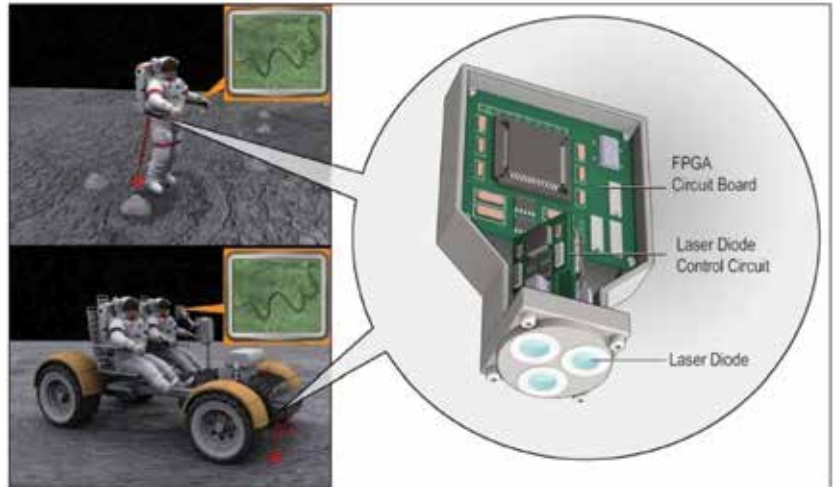

Identification and Significance of Innovation

To address the NASA need for navigation systems for planetary extravehicular activity (EVA), manned rovers, and lunar surface mobility units, Physical Optics Corporation (POC) proposes to develop a new Lunar completely Autonomous Automatic Surface Navigation (LAAN) system. The system incorporates POC's selfmixing laser interferometric speedometer sensor, POC's tunable liquid crystal lens autofocusing system, and a robust prediction tracking algorithm. The LAAN system offers position accuracy better than 2.5 m with 95 percent probability per 0.5 hr of motion without interaction with any other positioning system; and is compact (<10 in.³), lightweight (<8 oz), and low power. In Phase I, POC will demonstrate the feasibility of the LAAN prototype (TRL 4 at the end of Phase I). In Phase II, POC plans to develop a fully functional prototype and demonstrate its complete feasibility as TRL 6.

Technical Objectives

- Enhancement of self-mixing laser interferometric speedometer sensor parameters in data acquisition, signal processing speed, and parameters of its autofocusing system
- Development of the LAAN tracking prediction algorithm, including a kinematical model of a moving object
- Integration and testing of the LAAN hardware and embedded software
- Definition of commercial market for LAAN system

Work Plan

- Develop fast data acquisition and signal processing
- Design LAAN liquid crystal autofocusing optics
- Develop predictive algorithm for LAAN and LAAN simulation
- Integrate sensor module and predictive algorithm
- Demonstrate LAAN feasibility
- Explore the commercial potential and product viability
- Prepare and submit reports

NASA Applications

The new LAAN system will provide NASA capabilities for location awareness, precision position fixing, best heading, and traverse path planning for planetary EVA, manned rovers, and lunar surface mobility units.

Non-NASA Applications

Military applications of the LAAN will include navigation/position determination for ground platforms in urban area battlefields where the GPS does not work properly/destroyed; for dismounted soldiers, robots, and autonomous platforms (within buildings, tunnels, caves, etc.).

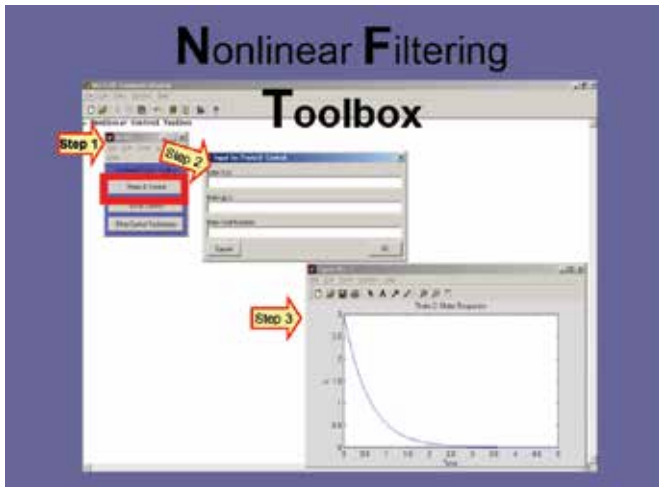

Technical Objectives

O-D, CBF, and Neural Network Estimator

- Error and Covariance Analysis
- Multiple sensor suites
- TRL 1 to 3 during Phase I

NASA Applications

- The algorithms and MATLAB-based filtering toolbox will be a valuable asset tool for NASA's orbit determination technologies.

Non-NASA Applications

- The algorithms and Kalman filter tool box can be sold to educational organizations for teaching estimation and orbit determination.

Identification and Significance of Innovation

O-D, CBF, Neural Network Estimator Algorithms

- Nonlinear filtering methods
- More accurate than linearized methods
- Computational Efficiency
- Methods focus on accuracy and efficiency
- Nonlinear filtering MATLAB toolbox

Technology readiness level (TRL) during Phase I

- 1 to 3

METRIC TRACKING OF LAUNCH VEHICLES

Toyon Research Corporation

2009 Phase I
04.01-8393

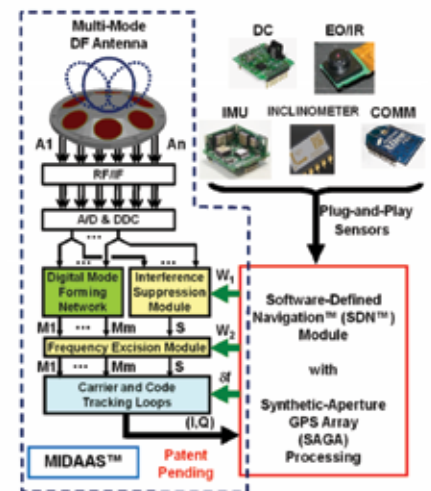

Identification and Significance of Innovation

- Active protection against GPS jammers
- Compatible with existing GPS receivers
- Higher performance using MIDAAS: Miniature Integrated Direction-finding Attitude-determining Anti-jam System
- Capable of recognizing multipath and GPS spoofing
- Tactical-grade accuracy with commercial-grade components and cost
- Plug-and-play navigation architecture

Technical Objectives

- Develop anti-jam front-end processor compatible with existing GPS equipment
- Design anti-jam baseband hardware
- Implement the hardware blocks in an FPGA
- Compare single-output configuration (compatible existing GPS receivers) GPS to tightly integrated design using all available information

NASA and Non-NASA Applications

- GPS-based positioning and attitude determination
- Zero-drift attitude system for unmanned/micro air vehicles (UAVs and MAVs)
- Navigation aid for hand-held GPS receivers and landrobots
- Orienting device for recreational and virtual reality systems

CONTINUATION METHODS AND NON-LINEAR/NON-GAUSSIAN ESTIMATION FOR FLIGHT DYNAMICS

Numerica Corp.

2009 Phase I
04.04-8416

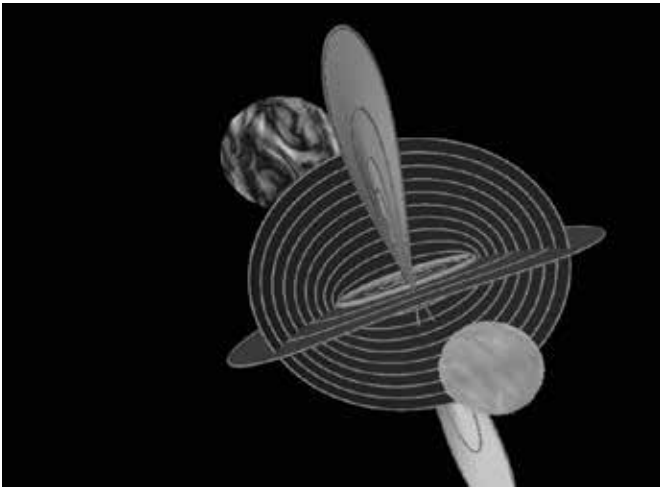

Technical Objectives

- Identify challenges in trajectory design and analysis that are not addressed by current techniques, especially in the presence of unstable trajectories and sensor measurements with substantial uncertainty
- Develop applications of numerical parameter continuation methods to these trajectories that provide novel insights into the dynamics
- Develop methods by which the uncertainty in both the dynamics and the measurements can be appropriately managed using advanced estimation techniques such as Gaussian sum filters
- Conceptualize a plan by which efficient implementations of such advanced techniques can be integrated into existing NASA software packages and work flows

NASA and Non-NASA Applications

There are several current state-of-the-art software packages that are clear and direct transition paths for the proposed work. In particular, there are the GPS-Enhanced Onboard Navigation Software (GEONS), the GPS-Inferred Positioning System and Orbit Analysis Software (GPSY), and the General Mission Analysis Tool (GMAT). Of the various packages, GMAT is the most directly applicable and will be the focus of the Phase I effort. Accordingly, these algorithms will find applicability in any preflight mission design, planning, and analysis activities that utilize these software.

In addition, the algorithms and software proposed herein will find applicability to many challenging problems, for both the Department of Defense and commercial entities, where complicated dynamics and uncertainty play a role.

Identification and Significance of Innovation

- We propose herein to augment current NASA state-of-the-art flight dynamics software with algorithms and software from two domains.
- First, we propose to use numerical parameter continuation methods to assist in computation of trajectories in complicated dynamical situations.
- Second, we propose to use advanced filtering techniques and representations of probability density functions to appropriately compute and manage the uncertainty in the trajectories.

Estimated technology readiness level (TRL) range at beginning and end of contract (1–9)

- 4
- 5

MULTIPURPOSE RADIO SIGNAL GENERATION SYSTEM FOR SPACE APPLICATIONS, SIMULATION, AND TESTING

Emergent Space Technologies, Inc.

2009 Phase II
04.02-8458

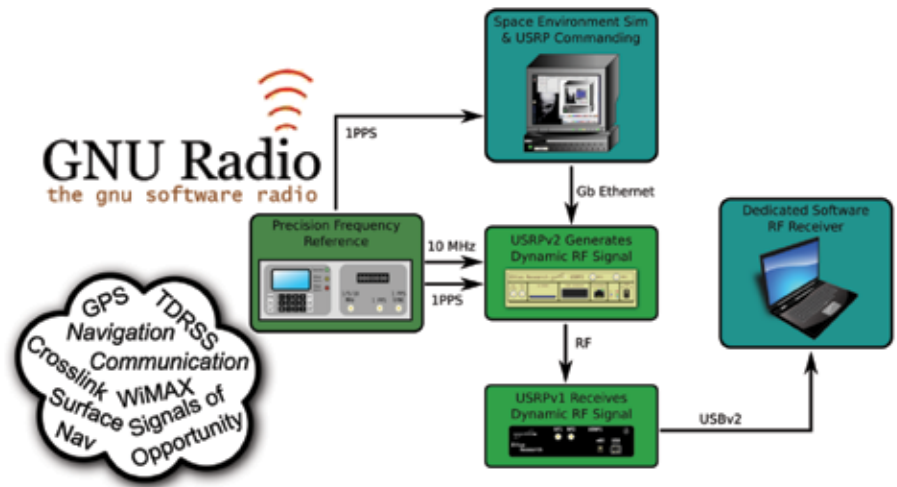

Identification and Significance of Innovation

Many upcoming space missions have very complex high Earth orbits that will present a challenge for the use of GPS as a primary source of navigation, though NASA has developed weak signal receivers that can accomplish this. Preflight testing and hardware acceptance become the problem since the GPS simulators used for these purposes are repurposed from terrestrial applications, and present difficulties for space-based testing. This work develops a simulator based on commercial-of-the-shelf (COTS) software-defined radio technology that is designed from the start for space applications. A Phase I effort demonstrated generation of a single GPS signal with the SDR hardware. Complex models are added via an open software interface, returning the expertise required for simulation studies to NASA. The system can also simulate communication waveforms.

Technical Objectives

- Design and develop a simulator system, based on Phase I prototype that can generate all in view satellite signals
- Retire risks inherent in design by building a functioning prototype
- Deliver working hardware to the Magnetospheric Multiscale (MMS), Geostationary Operational Environmental Satellite R-Series (GOES-R), or other ongoing missions

Work Plan

- System specification and design
- Multisatellite simulation in SDR
- Simulation fidelity enhancement (antenna gain, ionosphere, GPS yaw effects, and other error models)
- User interface development including closed loop trajectory testing with General Mission Analysis Tool (GMAT)
- Integration and test

NASA Applications

- Real-time closed-loop simulations of GPS and crosslink hardware for complex Human Exploration and Operations (HEO) missions such as MMS and GOES-R
- Customizable waveforms to meet mission specifications

Non-NASA Applications

- Any commercial satellite in high Earth orbit using GPS
- Department of Defense space applications
- University lab environments

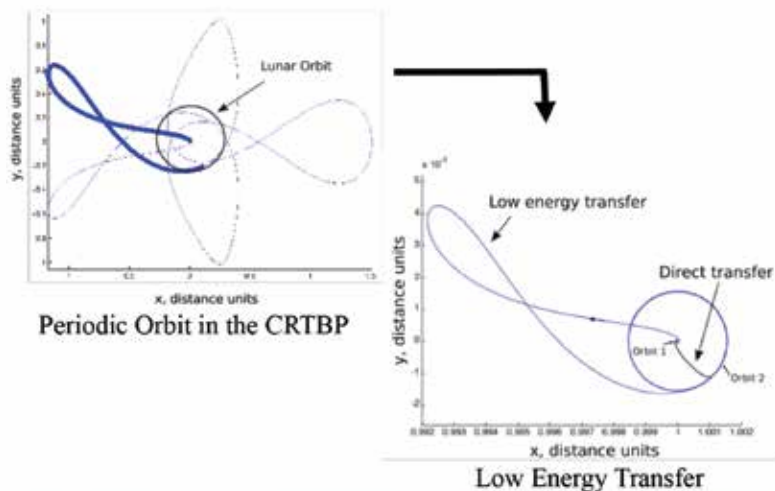

Technical Objectives

- Develop a tool for the automated design of periodic orbits in the Sun-Planet circular-restricted three-body problem (CRTBP) that serve as the reference orbits for low-energy mission planning
- Develop an automated tool for calculating low-energy orbit-to-orbit transfers in the CRTBP
- Develop a tool for translating orbits from the CRTBP to the restricted four-body problem through the iterative addition of complexity to the problem
- Develop a nonlinear targeting algorithm for converging on low-energy transfers in the dynamics of the full ephemeris problem
- Generalize the problem to any planetary system (e.g. Jupiter moon tours)
- Calculate lunar flyby low-energy transfers in an automated way
- Develop an interface with GMAT for post processing and visualization

NASA and Non-NASA Applications

These tools can be applied to any lunar mission to evaluate the savings possible via low-energy transfers. The automated nature of the toolbox would enable complex mission design by those who are not necessarily specialists in multibody dynamics. The tool would greatly aid the development of a sustained presence on the Moon through efficient low-energy trajectory design. Other potential customers include private lunar development (Google Lunar X-Prize) and NASA missions involving the tours of moons of other planets.

Identification and Significance of Innovation

The Low-Energy Mission Planning Toolbox is designed to significantly reduce the resources and time spent on designing missions in multibody gravitational environments. It provides a means for quickly planning low-energy trajectories in real-world environments and comparing their cost and transfer times to high-energy direct methods. The toolbox leverages recent research on low-energy mission design methods to produce algorithms that are stable, hold potential for automation in certain situations, and can be easily interfaced with the NASA open-source mission planning tool General Mission Analysis Tool (GMAT).

DEEP SPACE NAVIGATION AND TIMING ARCHITECTURE AND SIMULATION

Microcosm, Inc.

2009 Phase I
04.04-9179

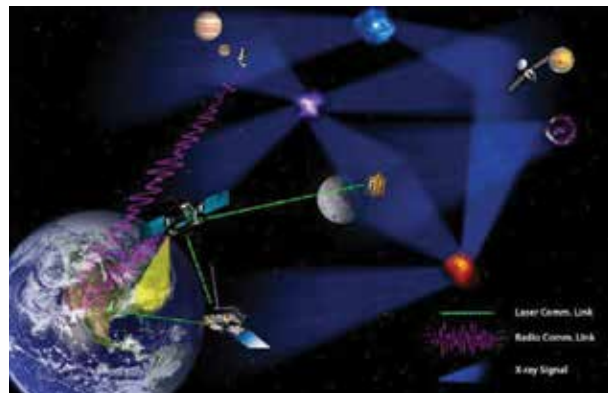

Image shows notional navigation and timing system architecture for full range of NASA missions, including Earth-orbiting, Lunar, Mars, and all other interplanetary missions, incorporating multiple data types.

Identification and Significance of Innovation

Microcosm will develop a deep space navigation and timing architecture and simulation, incorporating state-of-the-art radiometric, x-ray pulsar, and laser communications measurements. The solution will center on the maintenance and propagation of navigation states, time and associated uncertainties onboard each platform with filtering capabilities enabling updates based on all available data. Such data would include direct state and uncertainty updates via ground communication, radiometric- and lasercom-based range and range rate data from communication with ground stations and other spacecraft, time transfer from ground stations and other spacecraft, and x-ray pulsar-based navigation and time measurements (XNAV). This would enable significant improvements in spacecraft navigation and time determination for the majority of systems without access to GPS and would improve solutions for systems with GPS. With intervehicle communication, the line-of-sight (LOS) navigation precision achievable with current radiometric techniques can be achieved in the direction normal to the LOS from the Earth. Phase I will develop the architecture, performance estimates, and simulator requirements and preliminary design. Phase II will focus on detailed simulation development and on the transition of the capabilities into key NASA tools.

Expected technology readiness level (TRL) range at the end of contract

- 2 to 3

Technical Objectives

- Requirements Definition/Systems Engineering—Review of future NASA navigation and time determination needs and current technologies and plans for navigation, communication, and time transfer capability development. Considering issues such as how to infuse new measurement types into existing/planned infrastructure.
- Architecture Development—This is the design phase of the Phase I project, and the objective is to develop the system solution architecture as well as to develop a detailed MATLAB/Simulink simulation design and associated software development plans.
- Demonstration and Prototyping—Prototype and demonstrate, in the MATLAB/Simulink environment, key features and functions and to support system performance evaluation.

Work Plan

- Requirements Definition/Systems Engineering
- Architecture Development
- Demonstration and Prototyping
- Program Management

NASA Applications

The proposed navigation and timing architecture and simulation will directly support NASA advanced mission planning for both human exploration and robotic missions planned for the next 30 years. Incorporating these new capabilities, including x-ray pulsar-based navigation and lasercom-based navigation, into existing NASA tools such as GPS-Enhanced Onboard Navigation Software (GEONS) or General Mission Analysis Tool (GMAT) will provide augmented and enhanced navigation and timing solutions for next-generation space missions from low Earth orbit to the outer solar system and beyond. Microcosm envisions creating modular add-on software capabilities to these established NASA tools, which can be licensed to the government for use in ground-based simulation and development environments or for application onboard flight software.

Non-NASA Applications

Key non-NASA application will be primary or secondary navigation/timing services for Department of Defense (DoD) missions. The software modules developed for NASA can be easily transitioned to DoD space systems. Commercial systems with nontraditional spacecraft navigation techniques such as XNAV and LNAV, as primary or backup capabilities, may become the future software customers.

X-RAY DETECTION AND PROCESSING MODELS FOR SPACECRAFT NAVIGATION AND TIMING

Microcosm, Inc.

2009 Phase II
04.02-9182

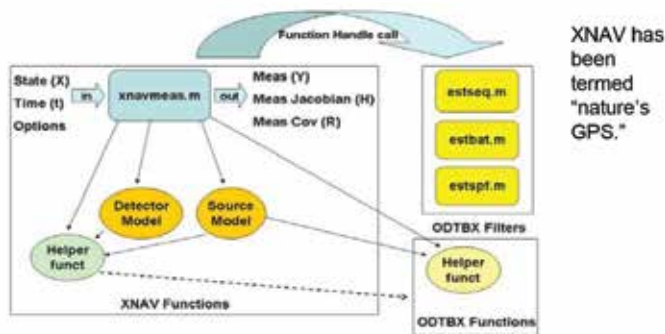

Highly stable pulsars can be viewed as “celestial lighthouses,” providing an oscillating signal with long-term stability comparable to current atomic clocks. These signals can be exploited to maintain accurate time and position in a way similar to existing deep space navigation systems. New algorithms will be developed in the ODTBX environment.

Technical Objectives

- ODTBX Simulation Development—Develop the XNAV simulation in ODTBX, continuing work started in Phase I, incorporating new photon processing algorithms.
- Photon Processing Algorithm Development—Develop refined XNAV algorithms for the estimation of spacecraft position, velocity, and time. Create initial detector model, improved source models for most relevant sources, to support end-to-end processing from x-ray photon detection to computing range measurements to navigation/time estimation.
- Demonstration/Validation—Use actual on-orbit data from previously flown x-ray detector missions to validate the photon processing algorithms through the simulation.
- Flight Software—Develop a flight experiment software package using the photon processing algorithms, validated with the ODTBX simulation.

NASA Applications

XNAV is a game-changing technology for NASA, enabling new missions, providing navigation autonomy and redundancy, and offering a path to reduce the scheduling demands on DSN, a valuable NASA asset. There are several promising NASA applications for XNAV where the improvements in navigational accuracy will either enable new missions or reduce their costs, including missions to the outer planets, and nonplanetary missions to deep space. Missions to Mars and the Moon can take advantage of the autonomous navigation capabilities of XNAV, providing redundancy and reducing the need for regular DSN contacts, lessening the burden on this over-taxed system.

Non-NASA Applications

The primary non-NASA XNAV applications would be to provide primary or secondary navigation services for Department of Defense missions. For medium Earth orbit (MEO), geostationary Earth orbit (GEO), Human Exploration and Operations (HEO), and even cis-lunar missions, where GPS has limited availability, XNAV can provide primary autonomous navigation capability. In addition, XNAV could provide an essential backup navigation capability for missions that normally rely on GPS, but require continuity of operations in the event of loss or denial of GPS.

Identification and Significance of Innovation

In Phase II, x-ray source-based navigation and timing (XNAV) performance will be enhanced through the development of single-photon processing algorithms, which utilize all available photon time data to improve the accuracy of XNAV. A detailed model of the XNAV system, including single-photon techniques will be implemented in Orbit Determination Toolbox (ODTBX), increasing its functionality and providing a valuable mission design tool. ODTBX will be further refined by enhancements to detector and source models, including the addition of new pulsars. Time transfer and barycenter correction effects will be added. XNAV measurement types will include additional absolute range measurement types and range rate measurements. Functions developed for ODTBX will provide support for XNAV and XTIM studies including enhanced dynamic functions and linearized process models for inclusion of clock and other bias states; and performance prediction for the single-photon processing approaches. The team will work with the Naval Research Laboratory (NRL), Johns Hopkins University/Applied Physics Laboratory (JHU/APL), and NASA Goddard Space Flight Center (GSFC), focusing on sources and detectors to develop improved models and assessing timing accuracy. This work will further validate the utility of XNAV for NASA, and develop and test relevant new technology to provide a rapid path to full flight software development.

Expected technology readiness level (TRL) range at beginning and end of contract

- 3
- 6

AUTOMATIC SOLAR AND CELESTIAL NAVIGATION ON THE MOON AND MARS

Micro-Space

2009 Phase I
04.03-9288

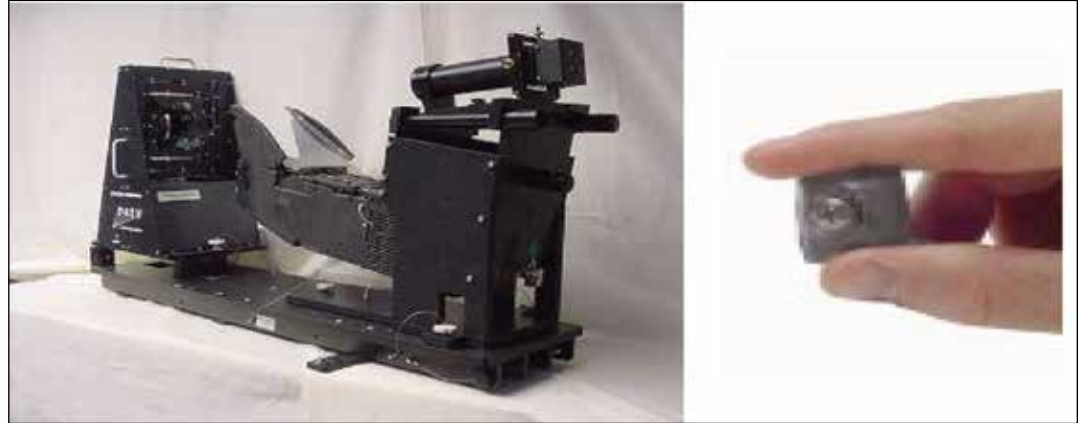

Micro-Space “Sub Pixel Processing” provides Extreme Resolution or “Sextant” resolution with mini camera.

Identification and Significance of Innovation
Extravehicular activity (EVA), or other travel on the Moon, has no GPS-like navigation or even a compass. A compact “Sun Sensing” camera, combined with accurate “Tilt Meter” data, and “Sub Pixel Processing” will give good compass directions, and one component of navigation.

This camera and algorithms, applied also to Earth’s image to aid navigation, will give a very accurate lunar surface position.

Night and far side EVA can use very similar car- top or helmet-top systems to track bright star positions.

There are no radio links or satellites necessary for navigation.

Expected technology readiness level (TRL) range at the end of contract

- 5 to 6

Technical Objectives

- Assemble breadboard with video camera and image capture to study “Sub Pixel Processing” resolution while imaging the Sun and also verify stellar imaging capability.
- Test resolution limits of Micro-Space “Tilt Sensor” systems is used as the “Bubble” of the “Bubble Sextant” used for celestial navigation over land or above clouds.
- Identify field of view necessary to achieve desired navigational resolution (with measured image analysis performance) and assemble a “compact” prototype which approximates this resolution and sky coverage.

NASA Applications

Limited to environments which lack GPS data, this technology will sustain standard quality celestial navigation autonomously.

This will enable extended EVA plus human and robotic vehicle travel for long distances on the Moon and Mars. (Earth direct, or satellite communication, can be sustained with simple systems incapable of supporting navigation.)

ADVANCED BAYESIAN METHODS FOR LUNAR SURFACE NAVIGATION

Autonomous Exploration Inc.

2009 Phase I
04.03-9337

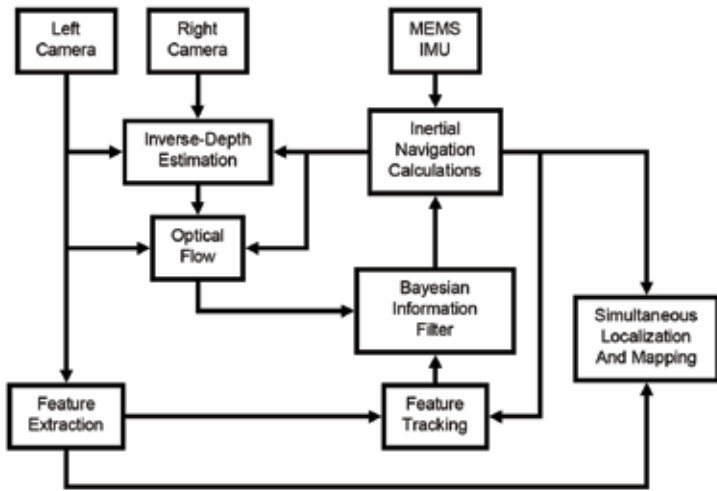

Technical Objectives

- Demonstrate the feasibility of implementing a fully Bayesian VO system on commercial off-the-shelf (COTS) hardware
- Identify design tradeoffs that can be used to speed up the algorithm with minimal impact on accuracy
- Characterize the error characteristics of the fully Bayesian VO
- Determine the impact of IMU errors on overall VO system errors. Evaluate the feasibility of using MEMS IMUs to develop a lightweight, low-power system

Work Plan

- Task 1—Software Implementation
- Task 2—Test Data Collection and Organization
- Task 3—Algorithm Optimization
- Task 4—Accuracy Determination

NASA Applications

- Speed and accuracy can make future rover missions more productive by enabling faster traverses.
- Lightweight and low power can help make it feasible to launch rover teams.

Non-NASA Applications

- Robustness can extend operation to areas where GPS is degraded or unavailable.

Identification and Significance of Innovation

Advanced Bayesian methods will leverage current computing technology to produce a highly accurate surface navigation system. The system will combine dense stereo vision and high-speed optical flow to implement advanced Visual Odometry (VO) that will accurately track faster rover movements. This will increase exploration productivity. Advanced Bayesian methods improve VO by using all image information, not just corner features. This improves VO performance in shadowed areas that yield only low-contrast images. High-speed, accurate VO may enable the use of lightweight, low-power microelectromechanical systems (MEMS) Inertial measurement units (IMUs).

Expected technology readiness level (TRL) range at end of contract

- Phase I: 3 to 4
- Phase II: 5 to 6

A LIGHTWEIGHT, MINIATURE INERTIAL MEASUREMENT SYSTEM FOR POSITION AND ATTITUDE ESTIMATION ON DYNAMIC PLATFORMS

Impact Technologies, LLC

2009 Phase II
04.05-9401

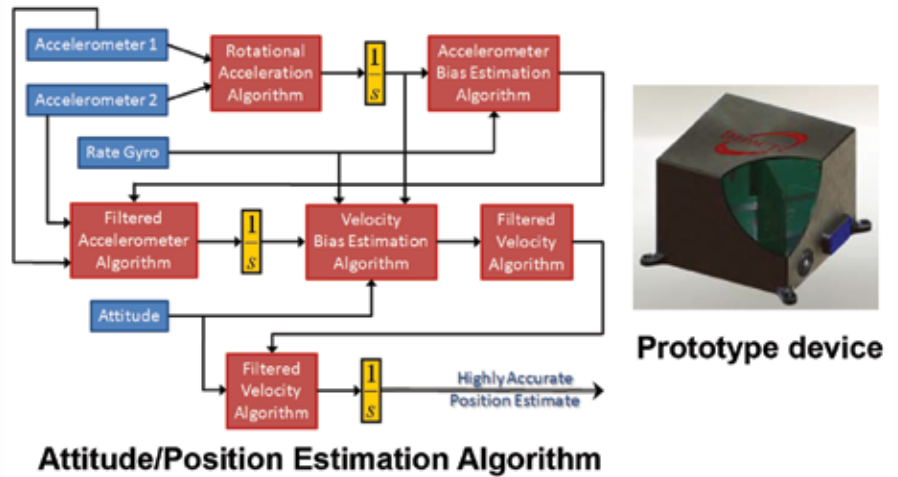

Identification and Significance of Innovation

A current problem of Space-Based Range technology applications is the extensive cost and delays in mission launch operations. Due to the immense cost and size of traditional INS and inertial measurement units (IMUs), the development of a miniature low cost, weight, and power, highly accurate INS system that provides stable and highly accurate positioning and attitude measurements in the presence of highly dynamical motions is desired. Our new method focuses on identifying the gravitational vector to bound sensor drift errors to achieve a high degree of accuracy. By employing a revolutionary highly accurate, miniature estimation device that can be fused with traditional measurement systems and GPS to provide inertial measurements, the extensive cost, size, and redundancy issues that arise with conventional methods may be avoided.

Technical Objectives

The objective of the proposed Phase II program is to develop and test a miniature attitude estimation prototype device coupled with acceleration measurements and a GPS receiver to provide highly accurate and stable inertial measurements and attitude/position estimates on highly dynamic platforms.

Work Plan

Specifically, this proposed project will perform the following tasks:

- (Quarters 1–4): Attitude Estimation Algorithm Update and Improvements
- (Quarters 2–5): Analysis of Miniaturization of Current Attitude Estimation Device
- (Quarters 3–6): Simulation Testing and Update Including a Rocket Simulation and Detailed Sensor Models
- (Quarters 3–6): Hardware and Prototype Fabrication
- (Quarters 5–8): Laboratory Testing and Optional Prototype Testing in a Relevant Vehicle; Final Report; Tech Transition Activities

NASA and Non-NASA Applications

The successful completion of the proposed work will lead to improvements in the safe operations of general aviation aircraft, suborbital carriers and aerial/ground robots operated in GPS-denied locations. The proposed technologies with an emphasis on real-time attitude and position estimation will be directly applicable to low-cost attitude determination on suborbital carriers, inertial measurement estimation, reusable launch vehicles, and space-based range applications. It will lead to benefits in the form of improved reliability, accuracy, and sustainability of safety-critical aerospace systems.

DESENSITIZED OPTIMAL FILTERING AND SENSOR FUSION TOOL KIT

Analytical Mechanics Associates, Inc.

2009 Phase I
04.04-9465

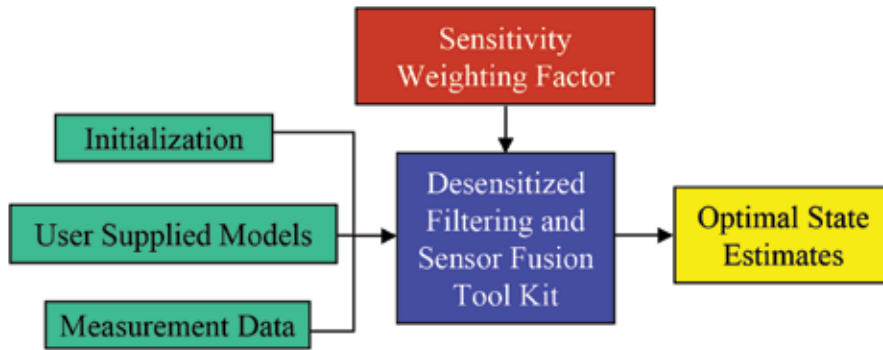

Technical Objectives

- Investigate the best approaches to reducing the sensitivity of the Kalman filter with respect to model parameter uncertainties
- Investigate the basic software design for the desensitized filtering and sensor fusion tool kit
- Investigate the best approach to integrate the tool kit modules with existing applications such as the STK Orbit Determination Tool Kit or the GPS-Enhanced Onboard Navigation Software

NASA Applications

- Spacecraft and aircraft ground or onboard facilities to process navigational data from multiple sensor sources
- Analysis and testing of flight software and onboard data processing algorithms

Non-NASA Applications

- Marine vessel navigation, commercial airliner navigation, seismic data acquisition and analysis, and atmospheric observation data collection and processing

Identification and Significance of Innovation

- Develop new and innovative desensitized optimal filters for navigation and sensor fusion applications that are robust with respect to model uncertainties.
- Create foundations for a navigation and sensor fusion tool kit that implements the research results as well as recent advances in robust and/or adaptive filters for non-Gaussian problems with uncertain error statistics.

LUNAR LOCALIZATION SYSTEM (LLS)

Utopia Compression

2009 Phase I
04.03-9624

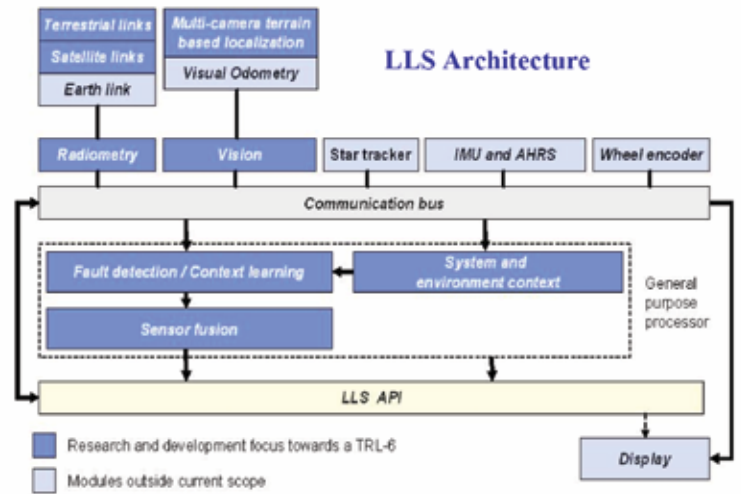

Identification and Significance of Innovation

- Localization is a basic requirement for applications such as navigation and safe-haven tracking.
- Localization would benefit from integrating pose estimates from multiple sensors like radiometry, inertial measurement unit (IMU), and vision to improve robustness.
- Radiometry information can be used from both satellite networks and terrestrial networks.
- Terrain matching based global localization using stereo cameras allows for localization in the absence of supporting infrastructure like satellites and beacons
- The system for the above requirements will need to be transparent and fault tolerant with as close to a plug-and-play architecture as possible.

Estimated technology readiness level (TRL) range at beginning and end of contract

- 1
- 4

Technical Objectives

- Study of Dilution of Precision on a Radiometry based localization using both satellites and terrestrial signals
- Prototype of a simulation system to show feasibility of recommended radiometry system
- Design and prototype of a vision based terrain matching for global pose estimation
- Sensor fusion design and prototyping along with fault detection

NASA and Non-NASA Applications

- Robust localization on the lunar surface
- Augmenting Global Navigation Satellite System (GNSS) with radiometry will allow GNSS providers to improve their service by improving positioning in tunnels, indoors, and in remote areas.
- Terrain matching based localization from vision has commercial value in robotics applications such as assistive robots in hospitals.

CELESTIAL X-RAY SOURCE MODELING AND CATALOGS FOR SPACECRAFT NAVIGATION AND TIMING

Microcosm, Inc.

2010 Phase I
04.02-8417

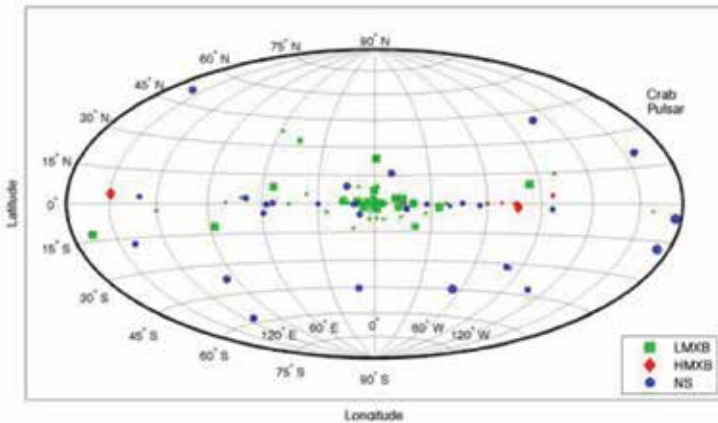

Galactic longitude and latitude plot of x-ray sources with properties beneficial to navigation measurements.

Technical Objectives

- Characterize x-ray sources for navigation purposes. Identify all pertinent and necessary parameters required to be determined from each star to be suitable for use in spacecraft navigation.
- Automate pulse shape catalog tools. Software tools that can be used to convert x-ray pulsar light curves into pulse shape models will be created, allowing XNAV system operators to update the XNAV catalog regularly.
- Automate XNAV/pulsar noise prediction tools. Software tools that are used to predict the performance of an XNAV system will be created and will be sufficiently automated to allow mission planners to use them in their design work.
- Aperiodic source evaluation: Aperiodic and/or transient sources will be evaluated for their potential to expand the XNAV system capabilities, for relative navigation and as complements to other measurements.
- Photon energy performance enhancement.
- Integrated catalogs of XNAV guide stars and XNAV-applicable aperiodic sources.

Work Plan

- Task 1—Periodic X-ray Source Characterization
- Task 2—Bright Aperiodic X-ray Source Characterization
- Task 3—Energy Dependent Pulse Analysis
- Task 4—Source Catalog

NASA Applications

XNAV is a game changing technology, which enables NASA missions, navigation autonomy, redundancy, and offers a path to reduce scheduling demands on NASA's Deep Space network (DSN) asset. There are several NASA applications for XNAV improved navigational accuracy to enable new missions or to reduce costs of planetary and nonplanetary deep space missions. Missions to Mars and the Moon can take advantage of the XNAV autonomous navigation to provide redundancy and reduce the need for regular DSN contacts to lessen the burden on over-taxed systems. The proposed x-ray source modeling and associated catalog will support all of these applications.

Non-NASA Applications

The primary non-NASA applications would be to provide primary or secondary navigation services to DoD missions, to MEO, GEO, HEO, and even cis-lunar missions, where GPS has limited availability. In addition, XNAV could provide an essential backup navigation for missions that normally rely on GPS, but require continuity of operations in the event of loss or denial of GPS.

Identification and Significance of Innovation

The Microcosm x-ray pulsar-based navigation and timing (XNAV) team will provide the software and modeling infrastructure for NASA to support XNAV operations, focusing on detailed x-ray source modeling. These models can be used to evaluate the potential of using measurements of photon energy and/or catalog sources to improve XNAV performance. Key goals are: characterize x-ray sources for navigation purposes; automate pulse shape catalog tools; automate XNAV/pulsar noise prediction tools; aperiodic source evaluation; photon energy performance enhancement; create integrated catalogs of XNAV guide stars and XNAV-applicable aperiodic sources; identify and document the key periodic x-ray source characteristics impacting the performance of the XNAV instruments and system. This comprehensive characterization categorizes and provides the necessary parameters regarding these celestial sources that make them beneficial for spacecraft navigation. Based upon past research work, specific information about each unique x-ray source must be attained in order for the source to yield its optimum capabilities. We will identify the appropriate parameters for characterizing aperiodic or transient sources for their use in navigation. Additionally, the existing x-ray source catalog will be updated and enhanced. Phase II will focus on implementing these source models in detailed XNAV simulations and potentially creating flight software versions of these models.

Expected technology readiness level (TRL) range at the end of contract

- 2 to 3

SECOND-ORDER KALMAN FILTER USING MULTICOMPLEX STEP DERIVATIVES

Emergent Space Technologies, Inc.

2010 Phase I
04.03-8473

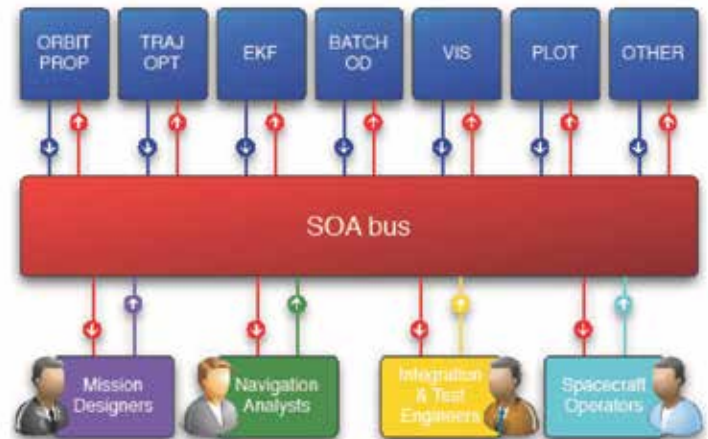

Notional SOA-Based Mission Design/OD Analysis Services

Identification and Significance of Innovation

The primary innovation is to employ multi-complex step derivatives (MCXD) to compute Jacobian and Hessian information necessary to implement a second-order Kalman filter (SOKF) making the higher-order nonlinear filter more tractable and practical for estimation of nonlinear systems. The secondary innovation is application of a service-oriented architecture (SOA) to integrate disparate NASA navigation and mission design software suites to provide the flexibility to use these capabilities in many different ways.

Expected technology readiness level (TRL) range at the end of contract (1–9)

- 4

Technical Objectives

- Evaluate navigation performance and computational burden of the SOKF/MCXD relative to a standard Orbit Determination Toolbox (ODTBX) EKF
- Identify possible General Mission Analysis Tool (GMAT) integration approaches and evaluate their advantages and disadvantages
- Determine how university students and faculty can be engaged to become members of the GMAT and ODTBX user and developer communities

Work Plan

- Define user requirements and use cases
- Integration trade study
- University outreach/curriculum analysis
- SOKF design and prototype development

NASA and Non-NASA Applications

- NASA applications of the proposed technology include
 - Robotic precursor and human missions to asteroids or Lagrange points
 - Robotic servicing or orbital debris removal missions
 - Conjunction assessment and collision avoidance maneuver planning for International Space Station (ISS)
- Navigation and mission design software as a service (SaaS) at NASA centers or for Department of Defense (DoD) and commercial customers
- Aerospace and software engineering services to deploy, train, use, and improve a service-oriented package of navigation and mission design software at a variety of NASA installations or for DoD and commercial customers

FAULT DETECTION AND ISOLATION OF SATELLITE FORMATIONS USING A GROUND STATION

SySense Inc.

2010 Phase I
04.03-8654

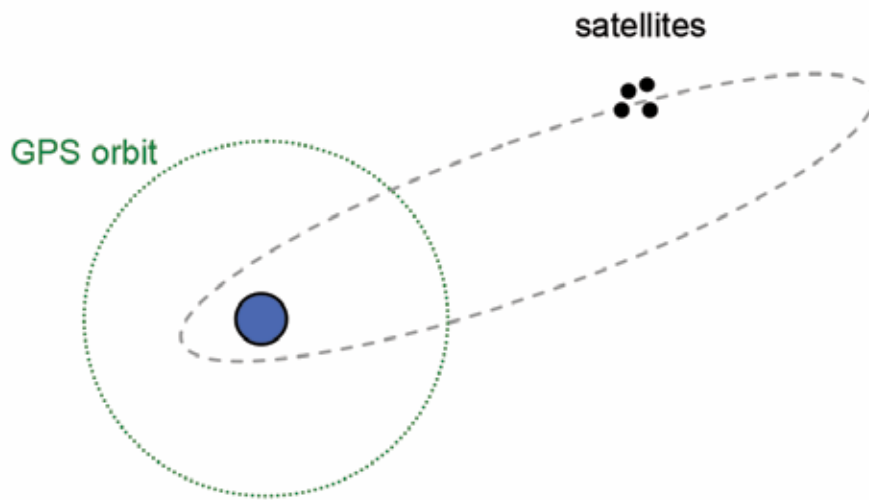

Technical Objectives

- Design a fault detection and isolation for faults in accelerometers and thrusters among 4 spacecraft in an elliptical orbit which goes beyond communication range and GPS coverage
- Determine analytical redundancies for rotational mode fault detection and isolation
- Characterize performance of fault detection and isolation algorithm by Monte Carlo simulations

Work Plan

- Simulate satellite formation, sensors, and loss of communication and/or GPS in MATLAB.
- Develop fault detection and isolation algorithm for accelerometers and thrusters.
- Characterize performance and capabilities of fault detection and isolation.
- Develop fault detection and isolation algorithm for star trackers and Sun slit sensor.

NASA and Non-NASA Applications

- Provide fault and redundancy management of spacecraft formations from a ground station.
- Practical alternative for fault detection and isolation for clusters of small unmanned vehicles, which do not have sufficient processing capability to perform detection and isolation autonomously.

Identification and Significance of Innovation

Develop a fault detection and isolation algorithm for precision formation flight and safety where the processing for detection and isolation is done at a ground station with intermittent communication with the satellites.

Expected technology readiness level (TRL) range at start and end of contract

- 1
- 3

FLEXIBLE PARTICLE FILTER NAVIGATION SYSTEM FOR ANALYSIS AND OPERATIONS

Odyssey Space Research, LLC
 2010 Phase I
 04.03-8803

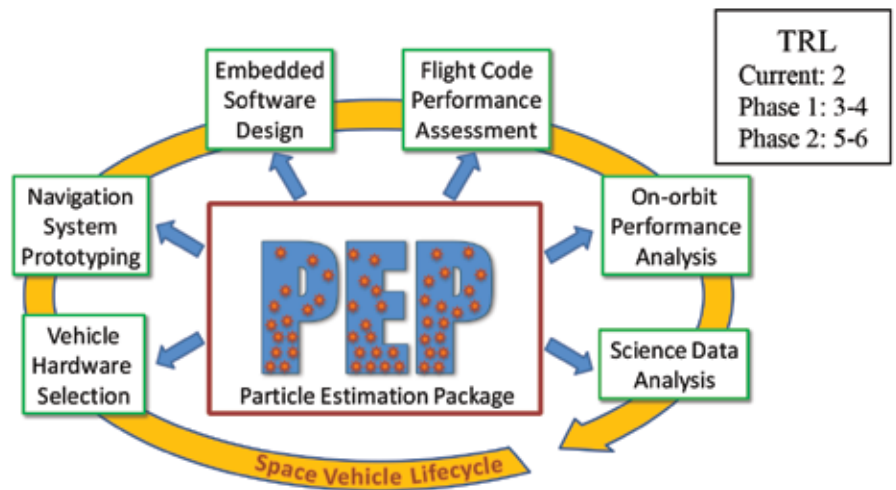

Identification and Significance of Innovation

A modular particle filtering navigator that can be easily integrated with existing products to provide position, navigation, and timing services.

- Unique particle filter design methodology that mitigates accuracy loss due to particle death
- Non-Gaussian process estimation via Leuven-1 and Cauchy noise estimation
- Extensible methods for combining diverse measurement types coming from multiple sensor systems operating at different rates
- Platform-independent software design that will be easily integrated into existing software packages
- Embedded real-time and analysis applications

Expected technology readiness level (TRL) range

- Current: 2
- Phase I: 3 to 4
- Phase II: 5 to 6

Technical Objectives

- Implement particle filtering algorithms based on Sequential Monte Carlo methods
- Design and implement non-Gaussian estimation methods and analyze performance capabilities
- Integrate navigator into existing analysis package and demonstrate filtering application
- Prove out package using difficult Earth-orbit navigation problem
- Deliver a working package integrated with additional software/hardware systems based on potential customers inputs
- Upgrade navigator functionality to meet expected needs of users
- Create several additional use cases that document how to implement instances of the navigator
 - Broad spectrum of integrated spacecraft application

NASA and Non-NASA Applications

- Ground/onboard positioning, sensor data analysis, navigation system design, and dynamic parameter estimation
- Navigation solutions, vehicle prototyping, inexpensive high-Earth-orbit determination
- GPS atmosphere delay estimation, GPS signal multipath mitigation, small body gravitation estimation, relative drag dynamics, and diverse sensor integration

MICROELECTROMECHANICAL SYSTEMS (MEMS) GYROSCOPE WITH INTERFEROMETRIC DETECTION

Fine Structure Technology LLC

2010 Phase I
04.01-9036

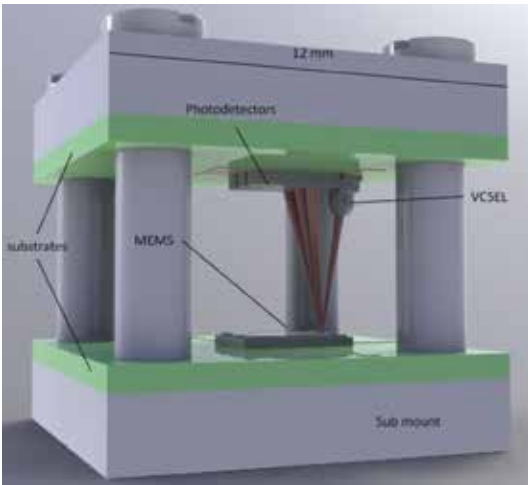

Technical Objectives

The Phase I objective is to demonstrate the feasibility of a MEMS gyroscope that uses micro-interferometric detection to measure proof mass motion.

- Develop a system-level model and design that captures the behaviors of interest and enables design decisions.
- Demonstrate sufficient optical performance for high-resolution sensing in a prototype scale package.
- Show sensing technique improves device stability by enabling a design with a large separation between the sense resonance frequency and drive resonance frequency.

Work Plan

- Complete MEMS model and design
- Fabricate MEMS design
- Complete electronics design and fabrication
- Complete submount design and fabrication
- Assemble prototype scale devices
- Test and debug prototype scale devices
- Evaluate test results and final reporting

NASA Applications

- Metric tracking of launch vehicles, on-orbit navigation for spacecraft, and stabilization for space telescopes

Non-NASA Applications

- Personal navigation systems, automobile navigation systems, precision drilling navigation for petroleum and mining, tactical navigation for small UAVs, and advanced interfaces for consumer products (cell phones and video games)

Identification and Significance of Innovation

The innovation is a MEMS gyroscope that uses an interferometric sensing technique to create a rate sensor with high sensitivity and performance stability comparable to that of fiber optic gyroscopes.

The significance of the innovation is that it will

- Produce a small, low-power, and inexpensive MEMS-based rate sensor that improves the performance of metric tracking hardware when operating in an environment with unreliable GPS signals
- Enable tactical-grade navigation in small unmanned vehicles
- Enable personal navigation systems in consumer electronics
- Enhance petroleum drilling and mining operations by improving wellbore navigation during directional drilling

Estimated technology readiness level (TRL) range at the end of contract

- 3

MINIATURIZED RADIATION HARDENED BEAM-STEERABLE GPS RECEIVER FRONT END

Tahoe RF Semiconductor, Inc.

2010 Phase I
04.02-9042

Tahoe RF GPS RFIC Improves SWaP by 30x

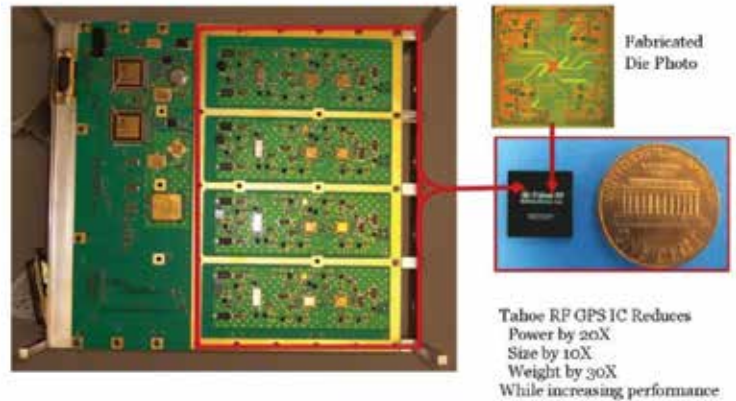

Identification and Significance of Innovation

The GPS receiver is a miniaturized integrated circuit (IC) that provides significant enhanced performance over existing discrete solution. The IC includes multiple coherent receive channels that in conjunction with an antenna array provides beam steerability for improved sensitivity, interference suppression, and mitigates multipath errors.

Expected technology readiness level (TRL) range at the end of contract

- 4

Technical Objectives

- Update the design
- Provide correction report
- Procure the fabricated design from MOSIS multiproject wafer (MPW) run
- Run functional tests and provide engineering samples

NASA Applications

- International Space Station X-ray Telescope
- Magnetospheric Multiscale Mission
- COSMIC II Missions
- Jason III Mission
- NICER Mission

Non-NASA Applications

- Precision GPSs for surveying and agricultural systems
- PNDs (Personal Navigation Devices)
- In-Vehicle Navigation Systems
- Telematics (Asset Tracking and Inventory Management)
- Recreational/Marine Navigation/Avionics

INNOVATIVE X-RAY STAR SCANNER FOR SPIN STABILIZED MICROSATELLITES

CrossTrac Engineering, Inc.

2010 Phase I
01.03-9516

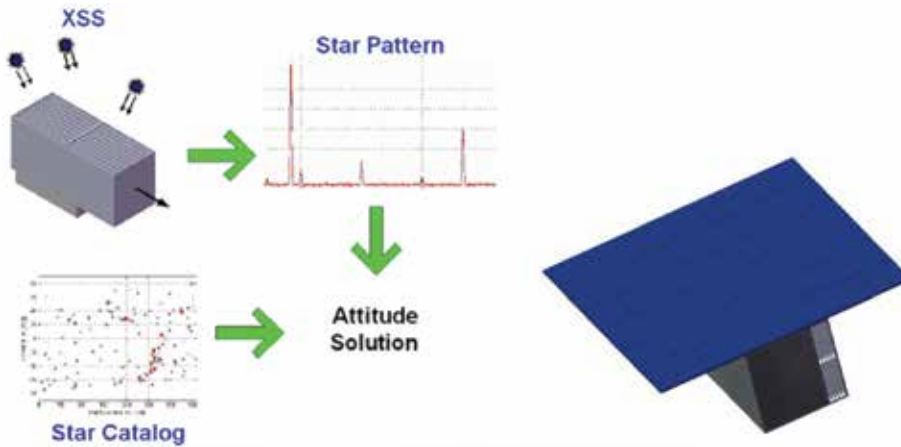

Technical Objectives

Demonstrate the feasibility of the X-ray Star Scanner (XSS) by

- Detailing XSS requirements and performance goals
- Identifying NASA mission opportunities
- Architecting necessary navigation algorithms
- Developing a simulation to support performance predictions
- Creating an XSS conceptual design including the selection of detector technology

NASA and Non-NASA Applications

Precision attitude sensor on spin stabilized microspacecraft performing a number of critical NASA missions:

- Earth-observing nonimaging missions
- Earth-observing imaging missions in a Thompson Spinner configuration
- Inertially pointed solar and astronomy missions
- Distributed space weather and space physics missions
- Lunar, planetary, and asteroid rendezvous missions

Precision attitude sensor on spin stabilized microspacecraft performing additional critical Department of Defense missions:

- Observing/reconnaissance missions
- Responsive space communications missions

Identification and Significance of Innovation

- Simple attitude sensor using x-ray sources as guide stars
 - Consists of photon detector, collimator, and processing electronics
 - Spinning spacecraft scans collimator over stars
 - Pattern of pulses created that is unique to orientation and spin rate
 - Pulse pattern compared to star catalog to determine spacecraft orientation and spin rate
- Game-changing technology creating an arcminute class attitude sensor for spin stabilized microspacecraft
- Expands capabilities of microspacecraft platforms
- Simple, robust technology
- Low mass and power make it compatible with CubSat-class spacecraft

Expected technology readiness level (TRL) range at the end of contract (1–9)

- 6

SPACE MISSION DESIGN IN THE VICINITY OF SMALL BODIES AND LIBRATION POINTS

Physical Optics Corporation

2010 Phase I
04.03-9816

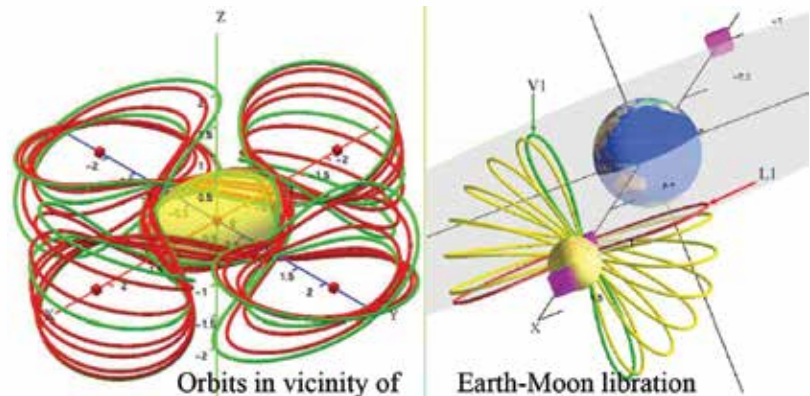

Identification and Significance of Innovation

To address the NASA need for advanced dynamical theories to space mission design and analysis in the vicinity of small bodies and libration points, Physical Optics Corporation (POC) proposes to develop a novel advanced Orbit Dynamic Computation Approach for Space Mission Analysis in the Vicinity of Small Bodies and Libration Points (ODYBOLP), with corresponding computational algorithms and software, based on advanced models of complicated celestial dynamical systems with libration points (LPs) and a pseudo-arc-length continuation method for computation of trajectories used for zero-fuel cost space guidance, navigation, control, and cargo transportation and long-distance passageways through the solar system. The ODYBOLP software will be integrated into standard NASA software packages General Mission Analysis Tool (GMAT) JAT, etc.). In Phase I, POC will demonstrate the feasibility of ODYBOLP by using its TRL-3 Phase I prototype software.

Technical Objectives

- Development of the dynamical theory describing the motion of an infinitesimal body in vicinity of small celestial bodies.
- Calculation of the periodic orbit families emanating from the libration points of the small celestial body, secondary, and some tertiary orbit families.
- Design and development of the basic software for visualization of small celestial body periodic orbits.
- Definition of the commercial market for the ODYBOLP system.

Work Plan

- Develop and analyze the dynamical system.
- Design and develop the software for calculations of the small body orbit families.
- Calculate the periodic orbit families of the dynamical system.
- Analyze stability of the calculated orbit families.
- Develop, design, and test the software for visualization of calculated orbit families.
- Explore the commercial potential and product viability.
- Prepare and submit reports.

NASA Applications

The proposed ODYBOLP will extend NASA leadership in design and analysis of space missions using unstable orbital trajectories in the vicinity of small bodies and libration points. It will improve libration point dynamical system models associated with the multibody problem and celestial small bodies and provide methods to use these models in space mission analysis and design. The ODYBOLP makes easier and faster the choice of suitable nominal orbits and near-zero fuel cost transfer trajectories for the mission designer.

Non-NASA Applications

The ODYBOLP approach has significant commercial applications for numerous Government agencies and commercial players of the national space and satellite market in effective and robust computations of trajectories of spacecraft used for space guidance, navigation, control, and cargo transportation and long-distance zero-fuel cost passageways through the solar system.

PARALLELIZATION OF SIGMA POINT AND PARTICLE FILTERS

Analytical Mechanics Associates, Inc.

2011 Phase I
04.03-8534

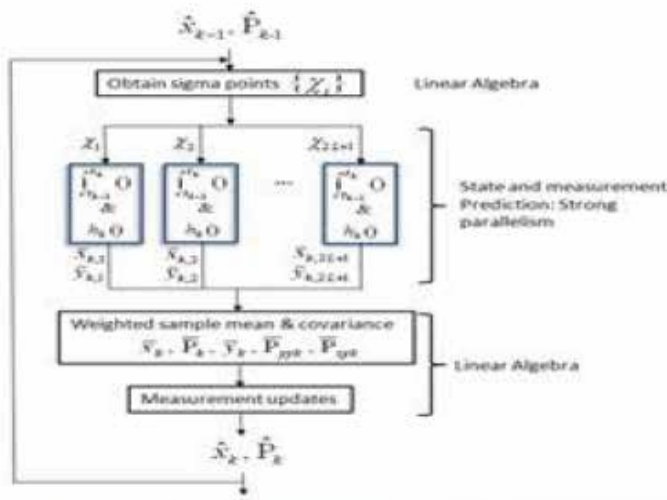

Technical Objectives

- Investigate parallelization of sigma point and particle filters on multicore personal computers as well as GPUs. Investigate the performance of the parallel filter modules on INS/GPS integration and orbital determination problems.
- Evaluate feasibility of real-time implementation of these filters.
- Investigate how the modules can be integrated with existing tools such as GEONS, GMAT, ODTBX, etc.

NASA Applications

- Spacecraft and aircraft ground or onboard facilities to process navigational data from multiple sensor sources
- Analysis and testing of flight software and onboard data processing algorithms

Non-NASA Applications

- Marine vessel navigation, commercial airliner navigation, seismic data acquisition and analysis, and atmospheric observation data collection and processing

Identification and Significance of Innovation

Inexpensive and readily available parallel computing architectures like the NVIDIA GPUs and multicore CPUs are used to exploit the massive parallelism inherent to sigma point and particle filtering techniques.

Filter modules for sequential and the two parallel computing architectures will be made, and can be used to replace existing filter modules depending on the hardware. These modules can also be made to integrate with existing tools such as NASA's GPS-Enhanced Onboard Navigation Software (GEONS), General Mission Analysis Tool (GMAT), and Orbit Determination Toolbox (ODTBX), etc.

Estimated technology readiness level (TRL) range at beginning and end of contract

- 3
- 4

COMPACT OPTICAL INERTIAL TRACKING FOR LAUNCH VEHICLES

MagiQ Technologies, Inc.

2011 Phase I
04.01-8702

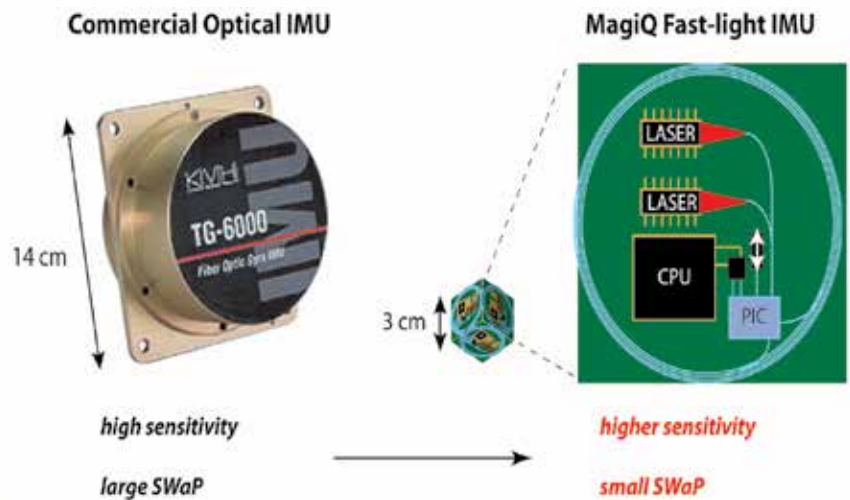

Identification and Significance of Innovation

We propose a method for developing a miniature all-optical Inertial Navigation System (INS). In an optical INS, the rotation sensitivity depends on the area enclosed by a circular optical path, so it is impossible to significantly reduce the size of a standard fiber optic gyroscope or ring laser gyroscope without sacrificing sensitivity.

However, using the phenomenon of fast light, which we will produce through Stimulated Brillouin Scattering (SBS) in a fiber, the sensitivity of a ring laser gyro of a given size can be enhanced by up to 106. We will use a fiber-based, fast-light-enhanced ring laser gyroscope to maintain the sensitivity of existing optical gyroscopes while greatly reducing the physical size of the sensing element. Combined with photonic integrated circuit technologies and standard optical accelerometers, the entire INS package can be greatly reduced in size, weight, and power, resulting in a rugged, compact, high-sensitivity INS ideal for launch vehicles and spacecraft.

Estimated technology readiness level (TRL) range at beginning and end of contract

- 2
- 5

Technical Objectives

- High Brillouin gain in a pumped fiber (sufficient to produce fast light in a short fiber with reasonable laser power)
- Near-zero group index (approaching infinite group velocity) in the fiber
- Narrow linewidth in a ring laser in order to obtain the desired rotation sensitivity

Work Plan

- Characterization of candidate fibers' SBS thresholds and selection of the best fiber.
- Characterization of the SBS gain and fast-light spectrum of selected fiber/laser combination.
- Construction and characterization of unidirectional ring laser.
- System design and modeling.
- Final Report and Phase II Proposal.

With these tasks completed, we will have a detailed design and specifications for a prototype to be developed in Phase II

NASA Applications

- Tracking and control of launch vehicles for placing payloads into orbital or suborbital trajectories.
- Precision inertial feedback during orbital maneuvers or stationkeeping operations on manned or unmanned spacecraft.
- Actively stabilize instrument platforms during sensitive astronomical observations or scientific measurements.

Non-NASA Applications

- Self-guided ordinance and unmanned aerial vehicles, where traditional high-sensitivity optical INS systems are too large to use.
- Stabilizing weapons platforms or communications devices mounted on ground and naval vehicles of all sizes.
- Commercial aircraft and marine vessels commonly use optical inertial measurement devices for navigation, stabilization, and tracking.

TRACKING AND DATA RELAY SATELLITE SYSTEMS (TDRSS) AUGMENTATION SERVICE FOR SATELLITES (TASS)-ENHANCED NEAR- EARTH NAVIGATION SYSTEM

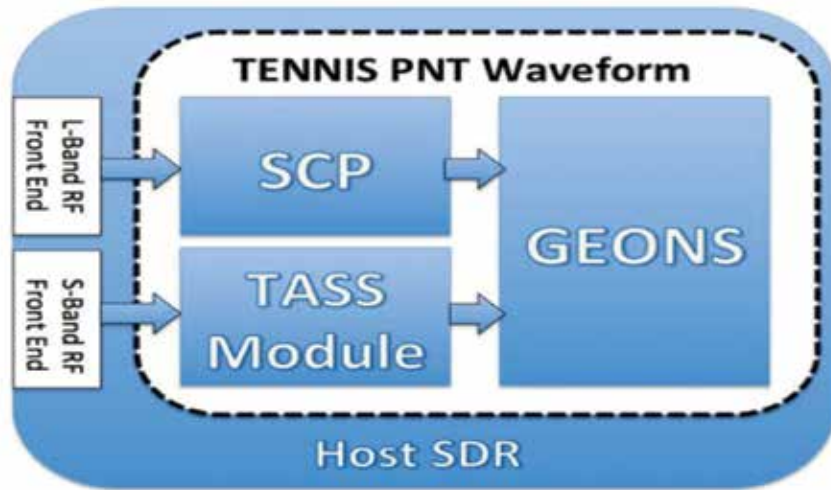

Emergent Space Technologies, Inc.

2011 Phase I
04.02-8761

Technical Objectives

- Demonstrate that the SCP measurements can be processed by GEONS
- Design an SDR capable of receiving TASS messages
- Develop the plan to integrate SCP, GEONS, and the TASS receiver to an existing qualified SDR hardware platform

Work Plan

- System Specification and Design Concept of Operations
- Design TASS SDR
- Process Codeless Data with GEONS
- Analysis of SDR Host Platforms for Waveform Mapping
- Project Management

NASA Applications

- TENNIS could be used on geodetic science missions like GRACE with its precise point and positioning capabilities
- Since TENNIS has a small footprint and is low SWaP, it could potentially be deployed on cubesats for atmospheric research
- The waveform can also be retasked to utilize signals other than GPS for navigation, such as Tracking and Data Relay Satellite System (TDRSS), Galileo, and GLONASS

Non-NASA Applications

- The proposed innovation would further enable proximity operations such as rendezvous and docking, formation flying, etc.

Identification and Significance of Innovation

Precise positioning, navigation, and timing (PNT) sensors that have low size, weight, and power (SWaP) are highly desired. This project aims to produce a state-of-the-art precise codeless GPS receiver capable of real-time decimeter level positioning. To meet this goal, the design will combine a unique codeless signal processing technique and GPS-Enhanced Onboard Navigation Software (GEONS) with the capability to ingest TASS messages. A suitable software-defined radio (SDR) platform will also be found to host these integrated technologies.

Estimated technology readiness level (TRL) range at beginning and end of contract (1–9)

- 3
- 5

ADVANCED EXOPLANET STAR TRACKER FOR ORBIT SELF DETERMINATION

Keystone Aerospace

2011 Phase I
04.02-9385

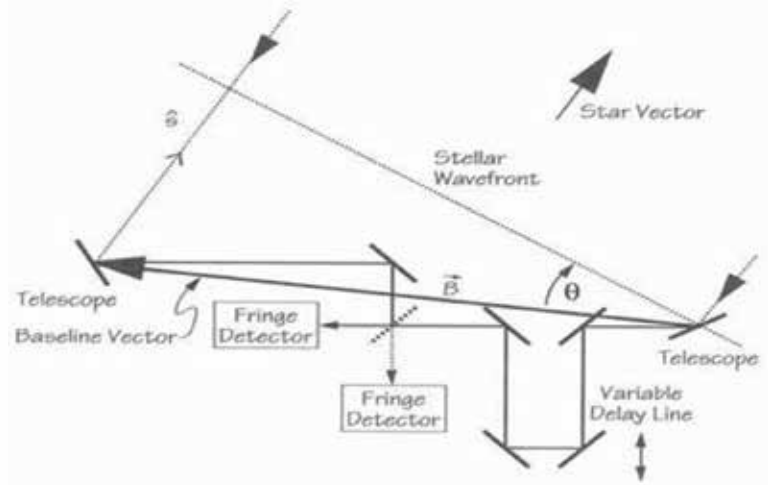

Identification and Significance of Innovation

Innovative hardware is proposed allowing for autonomous onboard calculation of a spacecraft's orbit by employing Doppler Spectroscopy and Astrometric techniques. The proposed advanced star tracker provides spacecraft orbit self-determination capabilities through the use of specialized reference stars that have exoplanet companions. The motion of exoplanets around a reference star's barycenter provides a stable, highly predictable natural signal pattern. An advanced exoplanet star tracker enhances mission navigation capabilities for future manned and unmanned space vehicles as well as reducing Deep Space Network (DSN) tracking requirements and resources.

Estimated technology readiness level (TRL) range at beginning and end of contract

- 2
- 3

Technical Objectives

Phase I research is a feasibility assessment leading to Phase II experiment development that can be integrated into a future hardware technology demonstration. The primary Phase I technical objectives are verification of concept feasibility, requirements analysis and definition, validation of system components, and development of stellar references. Work will occur over 6 months on the following planned tasks

- Verify desired technical features with NASA GPS-Enhanced Onboard Navigation Software (GEONS) capabilities
- Develop a preliminary stellar reference source catalog
- Perform requirements analysis and define necessary specifications
- Investigate and validate system technologies
- Evaluate various materials for suitability in the space environment
- Investigate software simulation benchmarks
- Develop technical goals and plans for Phase II research

NASA Applications

The proposed Exoplanet Star Tracker hardware would improve future navigation systems for NASA manned or unmanned space platforms. Primary autonomous navigation could be incorporated into spacecraft designed for geostationary, elliptical, or deep space orbits including missions to the Moon, comets, asteroids, libration points, and Mars. Resource demands on DSN would be decreased. Backup navigation for low- and medium-Earth-orbit satellites would be available when primary GPS navigation is lost.

Non-NASA Applications

The proposed Exoplanet Star Tracker hardware would improve future navigation systems for non-NASA entities such as the military, nonprofit research institutions, universities, and commercial satellite builders. Independent navigation in low and medium Earth orbits would be available when primary GPS navigation is unavailable. In 2010, satellite manufacturing revenues were \$10.8 billion.

ENHANCED PATH PLANNING, GUIDANCE, AND ESTIMATION ALGORITHMS FOR NASA'S GENERAL MISSION ANALYSIS TOOL (GMAT)

Decisive Analytics Corporation

2011 Phase I
04.03-9507

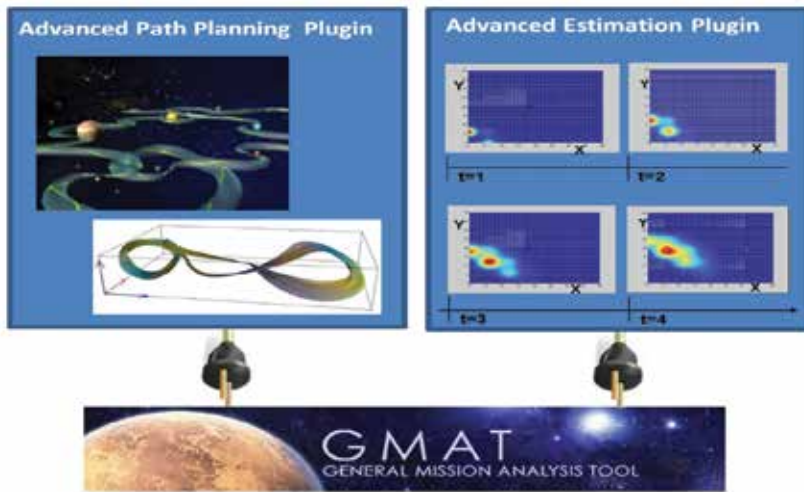

Technical Objectives

Advanced path planning and estimation capabilities in complex nonlinear dynamical regimes represent two of the greatest technical challenges of modern spaceflight. The proposed Phase 1 work and follow-on Phase 2 work will focus on incorporating the latest advancements in both of these areas into the GMAT. Phase 1 will focus on the software development, integration, testing, and validation of two prototype GMAT binary plug-ins:

- The APP plug-in will integrate a multiphase targeting framework during Phase 1. This capability is necessary to facilitate the follow-on Phase 2 work, which will further focus on integrating a Dynamical Systems Analysis Toolbox (DSAT) into APP, and a related visualization module that leverages DSAT's output. The combined functionalities of these modules will allow end users to effectively employ a dynamical systems approach for trajectory design in complex multibody regimes, such as the region near the libration points.
- The AE plug-in—built around Guide and Adapt (a suite of tools developed by Decisive Analytics)—will facilitate estimation processes that exhibit multimodal probability densities by incorporating estimation algorithms that adequately capture the impact of nonlinearities in the estimation process.

NASA Applications

The APP plug-in will offer GMAT end users enhanced mission design capabilities in complex multibody regimes, such as the region near libration points or near small celestial bodies. The AE plug-in will offer GMAT end users estimation techniques that adequately characterize the effects of nonlinearities in the estimation process so they may effectively analyze, for instance, problems involving multimodal probability densities.

Non-NASA Applications

The APP plug-in includes a generalized multiphase targeting framework that is relevant to autonomous vehicle guidance in general. Furthermore, the AE plug-in is built around Guide and Adapt, tools built at Decisive Analytics under contract with the Missile Defense Agency and the U.S. Air Force. Any new developments integrated into the AE plug-in will ultimately also benefit our existing customers.

Identification and Significance of Innovation Integration of Advanced Path Planning (APP) and Advanced Estimation (AE) capabilities into NASA's GMAT.

- The APP GMAT plug-in will enable enhanced mission design capabilities that incorporate a dynamical systems approach to mission design, along with multiphase path planning tools and enhanced visualization techniques that leverage GMAT's existing graphics engine. This will offer end users a diverse toolbox of capabilities to study complex problems in multibody dynamics, from libration point mission design to formation flight applications.
- The AE GMAT plug-in will incorporate modern estimation capabilities into GMAT's repertoire of tools, including but not limited to Gaussian Mixture Models and Unscented Kalman Filters, along with other advanced algorithms currently available within Guide and Adapt, the underlying suite of tools—developed at Decisive Analytics Corporation—around which the AE plug-in is designed.

Estimated technology readiness level (TRL) range at beginning and end of contract

- 3
- 5

ADVANCED SPACECRAFT NAVIGATION AND TIMING USING CELESTIAL GAMMA-RAY SOURCES

ASTER Labs, Inc.

2011 Phase I
04.02-9730

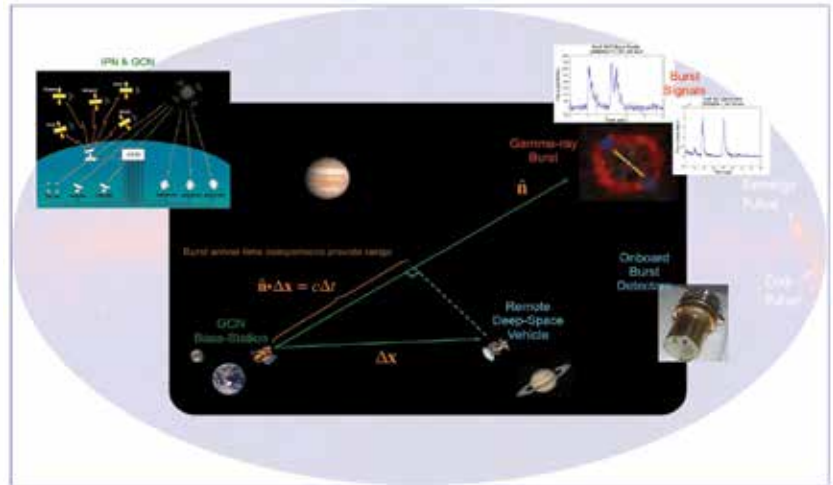

Identification and Significance of Innovation

- Novel enabling technology for interplanetary navigation
- Utilize known and new gamma-ray sources with enhanced high-energy detector components
- Independent three-dimensional spacecraft position determination anywhere in solar system

Current: ~300 km

Eventual: <3 km (one sigma)

- Utilize real data from Swift, Fermi GBM, and Inter-Planetary Network (IPN) spacecraft to demonstrate capabilities and performance
- Build upon and extend XNAV+XTIM innovations (NASA and Defense Advanced Research Projects Agency (DARPA)), pushing to higher photon energy regime (>20 keV)

Estimated technology readiness level (TRL) range at beginning and end of contract

- 3
- 5

Technical Objectives

Design a new gamma-ray source-based navigation for deep space vehicles by identifying burst characteristics and catalogue pulsar sources, design enhancements for GRB detectors, prototype navigation algorithms, and design system architecture.

Work Plan

- Task 1—Gamma-Ray Source Data
 - 1.1 Gamma-Ray Burst Source Characteristics
 - 1.2 Gamma-Ray Pulsar Source Catalogue
- Task 2—System Architectural Design
 - 2.1 System Engineering and Requirements
 - 2.2 Sensor Hardware Components
 - 2.3 Benefits Assessment
 - 2.4 Applications and Use Cases
- Task 3—Performance and Error Budgets
 - 3.1 Gamma-Ray Source Error Contribution
 - 3.2 Detector and IPN Error Contribution
 - 3.3 Navigation Components Error Contribution
 - 3.4 System-Level Errors
- Task 4—Navigation Algorithms
 - 4.1 Relative Navigation Time of Arrival (TOA) Measurement
 - 4.2 Navigation Kalman Filter Implementation
 - 4.3 Simulation Architecture Design

NASA Applications

- Independent deep space and exploration mission self navigation
- Augment DSN with off-axis ranging and reduce workload
- Solar storm warning and astronaut radiation hazard detection system
- Enhanced components for future Explorer missions

Non-NASA Applications

- Department of Defense and commercial deep space ventures
- Enhanced detectors for medical and diagnostic imaging, as well as homeland security

ACCURATE TIMEKEEPING WITH AN ENSEMBLE OF CLOCKS

Perichoro LLC

2012 Phase I
H9.04-9432



Technical Objectives

- Analysis for the proposed dynamical confidence intervals for processing the output of the clocks in an ensemble of clocks
- Design and development of a simulator for the proposed dynamical confidence intervals for processing the output of the clocks in an ensemble of clocks, based on the analysis
- Simulations with the simulator to demonstrate the performance of the proposed dynamical confidence intervals for processing the output of the clocks in an ensemble of clocks
- Plan for a follow-on Phase II contract
- Preparation of a final report on the technical feasibility with a Phase II Integration Path

Work Plan

- Perform the analysis for the proposed dynamical confidence intervals for processing the output of the clocks in an ensemble of clocks
- Perform the design and development of a simulator for the proposed dynamical confidence intervals for processing the output of the clocks in an ensemble of clocks, based on the analysis of the preceding Task 1
- Perform simulations with the simulator to demonstrate the performance of the proposed dynamical confidence intervals for processing the output of the clocks in an ensemble of clocks
- Perform the planning for a follow-on Phase II contract
- Perform the preparation of a final report on the technical feasibility with a Phase II Integration Path

NASA Applications

- The application of the proposed innovation in independent, accurate timekeeping, independent of any external reference time such as UTC is especially important for NASA's space missions, particularly, NASA's Space Communications and Navigation (SCaN) Program.

Non-NASA Applications

- Another Government agency that could be a market for such independent, accurate timekeeping is the Department of Defense. For example, submarines could use it to avoid the need to receive radio signals for keeping onboard clocks running on time.

Identification and Significance of Innovation

The proposed innovation is to accuracy in timekeeping independent of any external reference time, such as UTC. Individual clocks lose accuracy as time passes due to the physical effect called bias drift. The proposed innovation is a process, implemented as a real-time computer program, for combining the time-dependent output of an ensemble of clocks to counteract this loss of accuracy by the individual clocks of the ensemble of clocks. The processing method of the proposed innovation is based on the fundamental statistical concept of confidence interval for statistically characterizing the time-dependent output of clocks, and so are time-dependent or dynamical. The benefits of this method are

- It is a purely statistical method of estimation of numerical quantities, and therefore does not require any mathematical modeling of clocks
- No statistical models, namely no mathematical modeling of probability distributions
- No Kalman filter
- Will work with any kind of clock

Estimated technology readiness level (TRL) range at beginning and end of contract

- 0
- 3

ADVANCED TECHNIQUES FOR NONCOLLOCATED FAULT DETECTION OF SATELLITE FORMATIONS

SySense, Inc.

2012 Phase I
H9.04-9443

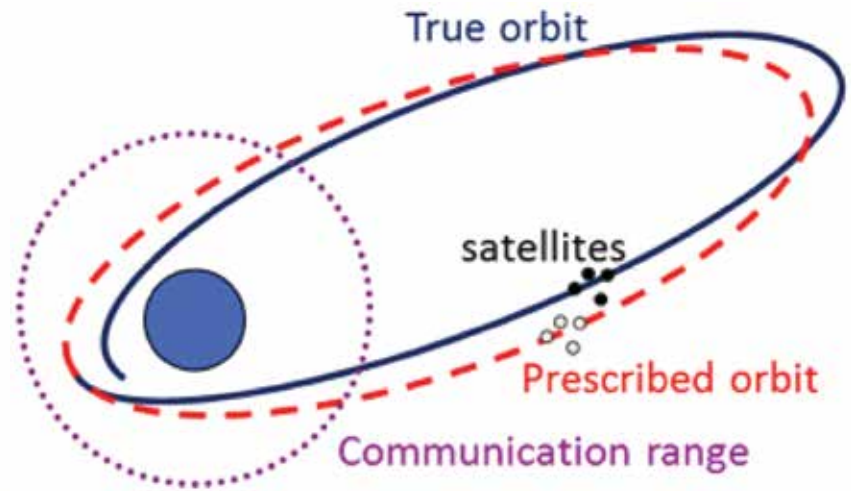

Identification and Significance of Innovation

To increase the safety of spacecraft formation flight missions, mission designers may utilize algorithms for the detection, isolation, and identification of system faults via data analysis on a ground station. An important component of such an algorithm is the fault detection filter, which compares measurements to estimates based on known system dynamics. A previous study revealed that linearized detection filters do not operate reliably in highly nonlinear dynamical environments. Three types of filters are proposed to be designed and characterized. The first is the linearization point reset method, which estimates the linearized dynamic environment based on the most recent measurement and the nominal orbit. The second is the extended filter method, which uses the full nonlinear dynamics to propagate the state estimate. The third is a hybrid of the first two. Each method may offer a significant improvement over the established linear fault detection theory.

Estimated technology readiness level (TRL) range at beginning and end of contract

- 1
- 3

Technical Objectives

- Derive the extended fault detection filter
- Design the extended, linearization point reset, and hybrid noncollocated fault detection filters to detect faults in relative position measurements and thrusters among four spacecraft in a cluster near a highly elliptical orbit
- Characterize performance of the noncollocated fault detection filters via Monte Carlo simulations

Work Plan

The extended detection filter will be derived based on the well-known extended Kalman filter, and its feasibility for the current problem will be analyzed and verified. Once a sufficient analysis of the proposed detection filter methods has been completed, they will be designed for a representative suite of instruments and faults on a remote spacecraft formation in the MATLAB simulation environment. The spacecraft formation will be simulated in a highly elliptical orbit in which there are measurement interruptions both planned (e.g., GPS constellation signal loss due to distance) and unplanned (e.g., data transmission loss due to solar activity, etc.). Finally, the performance of each detection filter, that is, probability of false and missed alarms and speed of fault detection, will be characterized via Monte Carlo simulations for various fault history and data loss scenarios.

NASA Applications

- NASA flight test experiments for clusters of resource-limited satellites that cannot run code not already associated with flight control and payload
- Ground station software suite for existing NASA formation flight missions such as the Magnetospheric Multiscale (MMS) mission and formation flight experiments with the internationally constructed “A Train” spacecraft, including CALIPSO, Aqua, Aura, CloudSat, and most recently SHIZUKU.

Non-NASA Applications

- Department of Defense, commercial, and university-level satellite, unmanned aircraft, and robotic formation flight and coordinated control missions. Two examples include the SpaceX resupply missions to the International Space Station (ISS) or unmanned military aircraft formation flight for fuel savings.

AN INTERACTIVE VISUAL ANALYTICS TOOL FOR NASA GENERAL MISSION ANALYSIS TOOL (GMAT)

Decisive Analytics Corporation

2014 Phase I
H9.04-9272

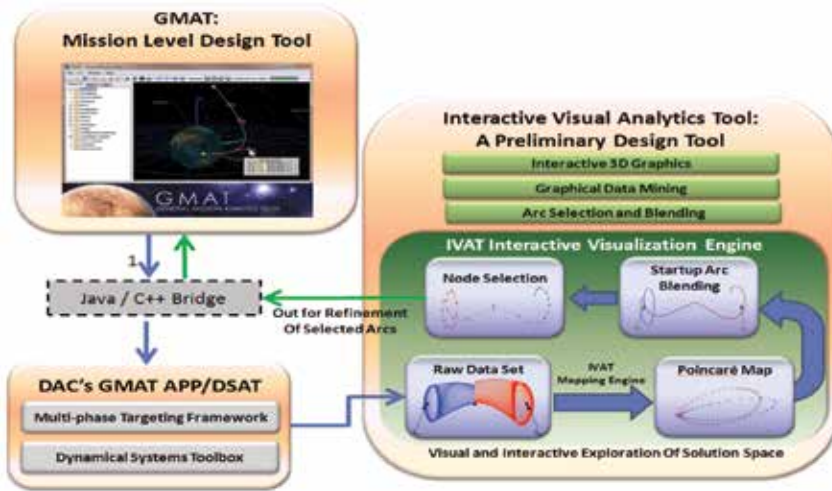

Technical Objectives

The mission design process can be broadly divided into two phases: the selection of candidate arcs and follow-on refinement processes. NASA's existing set of refinement tools are largely gradient based, meaning they rely on the availability of suitable startup arcs. The process of exploring the vast space of candidate options, and the subsequent selection and blending of selected arcs, is facilitated by the proposed IVAT interface. The primary Phase 1 Technical Objective's (TO's) focus is on the development of the underlying IVAT mapping engine and a prototype of the IVAT.

Work Plan

- TO #1: Under this technical objective, DAC will develop the underlying algorithms and software infrastructure that comprise the computational engine of IVAT. This component will enable the systematic computation and parameterization of user-defined Poincaré maps for a given dynamical system.
- TO #2: Under this technical objective, DAC will develop an initial prototype of the IVAT visualization engine and interface by leveraging jzy3d and jogl, open-source libraries that facilitate both the integration of three-dimensional visualization and the more advanced interactive capabilities sought for IVAT over the course of Phases I and II.

NASA Applications

At the top level, our commercialization strategy will pursue a mix of software sales and of services for subject matter experts. Within sales, we have existing relationships with commercial-off-the-shelf software vendors that could allow integration with existing products with customer bases, and we will also support enhancements to the capability as provided through GMAT. We have an existing contract based for providing services in related areas to NASA in collaboration with university partners.

Non-NASA Applications

The U.S. Air Force is an existing customer and has directly related technology needs. Through both internal efforts and partnerships, we will also seek foreign sales through commercial tools, and will exploit the ubiquitous nature of the Poincaré map approach to seek sales for applications beyond mission planning. Examples may include sales as a third-party software provider for MATLAB.

Identification and Significance of Innovation

The goal of any trajectory design process is to identify paths that transfer a vehicle from its point of origin to some specific destination, subject to constraints. This process is divided into two primary aspects: (1) the identification of candidate startup arcs and (2) the subsequent refinement of those solutions, via targeting or optimization processes. In support of this process, the proposed innovation focuses on the development of an Interactive Visual Analytics Tool (IVAT). IVAT facilitates the exploration and data mining of the space of candidate solutions leading to the refinement phase. The IVAT leverages the latest advances in advanced dynamical theories and visual analytics, and GMAT's Advanced Path Planning (APP) and Dynamical Systems Analysis Toolbox (DSAT), developed by Decisive Analytics Corporation (DAC). GMAT is selected as the technology demonstration platform, but our target design supports stand-alone operation, which benefits any gradient based refinement tool.

Estimated technology readiness level (TRL) range at beginning and end of contract

- 2
- 3

INTEGRATED SPACECRAFT NAVIGATION AND COMMUNICATION USING RADIO, OPTICAL, AND X-RAYS

ASTER Labs, Inc.

2014 Phase I
H9.05-9729

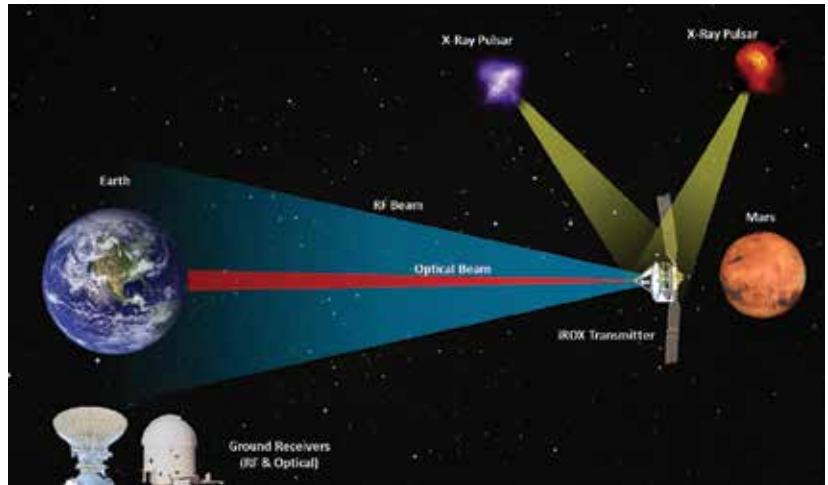

Identification and Significance of Innovation

- Novel enabling technology for Earth orbit and interplanetary navigation
- Utilize x-ray photons from celestial sources (pulsars) to provide absolute position and attitude determination
- Utilize radio dish to observe radio pulsars for navigation
- Integrated radio, optical, and x-ray technology for communications (iROX)
- Provides beaconless pointing of iROX communication system at distances greater than Mars (>2 AU)
- Independent navigation capability reduces Deep Space network (DSN) workload
- X-ray transceiver concept for additional relative navigation capability

Estimated technology readiness level (TRL) range at beginning and end of contract

- 3
- 6

Technical Objectives

- Design an integrated navigation technology using X-radiation photons
- Perform systems engineering analysis of the iROX design concept
- Identify specific missions and cases that can take advantage of this technology
- Develop key systems requirements for each selected use case
- Evaluate radio pulsar observations using the iROX radio dish antenna
- Integrate the iROX simulation using XPRESS and XNAV+DSN EKF simulations
- Evaluate existing modulated x-ray detector designs over specified energy ranges for relative ranging
- Determine system-level performance through error-budget and simulated measurement analysis
- Review potential NASA applications, prioritize use cases, and identify direct benefit-cost assessments to these NASA missions

Work Plan

- Task 1—iROX Architectural Design
- Task 2—X-ray Source Navigation Augmentation Methods
- Task 3—iROX System Evaluation

NASA Applications

- Accurate deep space navigation and attitude
- High-rate data deep space communication
- High-definition video transmissions
- Accurate relative navigation for formation flying

Non-NASA Applications

- High-data-rate communication for Department of Defense and commercial satellites
- Improved detectors for manufacturing, production, and inspection, as well as for Department of Homeland Security (DHS)
- Enhanced x-ray pulse generators and detectors for medical and diagnostic imaging
- Technology for reentry and hypersonic communications during radiofrequency blackout

INTERFEROMETRIC STAR TRACKER FOR HIGH-PRECISION POINTING

Optical Physics Company

2014 Phase I
H9.05-9750



Technical Objectives

Optical Physics Company (OPC) proposes to adapt the precision star tracker it is currently developing under several Department of Defense (DoD) contracts for deep space lasercom beam pointing applications. The advantages of using an interferometric star tracker for beam pointing are many and include

- Celestial-reference-based beam pointing eliminates need for having a ground-based beacon for return beam pointing.
- Precision star tracker can be part of the spacecraft attitude control subsystem, thus allowing a single high-performance instrument to support both attitude control and lasercom beam pointing functions.
- By allowing the lasercom system to point with a faint beacon and/or weak stars, the same lasercom system architecture can be employed for both deep spaceflight terminal and the near-Earth terminals operational from near orbit to very deep space mission.

Work Plan

The Phase I will develop the concept, the design of the Precision Pointing Platform, and validate its functionality and performance using detailed simulations that include models of the active isolators and the jitter environment with high fidelity. The simulation will use a realistic star background. Furthermore, Phase I work will produce a pointing error budget that takes into consideration effects of signal-to-noise ratio (SNR), unrejected platform jitter, alignment errors, and optical fabrication errors.

NASA Applications

The most immediate NASA application of this technology is in the deep space optical communication area. The precision star tracker offers the ability to communicate from a near-Earth or deep space (up to 40 AU) spacecraft platform using a narrow beam aimed precisely at a beaconless receiver. OPC has been funded recently by Jet Propulsion Laboratory (JPL) to investigate if this star tracker can be used for a spinning spacecraft.

Non-NASA Applications

OPC is currently building a cubesat star tracker that will be delivered to DoD. Another application is GPS-denied navigation; an acute need that has increased in the past few years. OPC is building three product lines around the interferometric tracker technology for transition.

Identification and Significance of Innovation

Laser communications (Lasercom) technology offers the promise of much higher rate data returns while reducing the size and weight of the telecommunications package for deep space missions. The problem of pointing a laser signal can in general be decomposed into the problems of (1) stabilizing the optical line of sight (LOS) and (2) providing the appropriate pointing reference to the receiver location. For near-Earth lasercom systems, this problem has been solved using a cooperative beacon source. However, in deep space instead of using a beacon signal to provide the LOS reference and for pointing stabilization, one can accomplish the LOS stabilization using a vibration isolation platform. The proposed project will investigate using a high-precision star tracker for this purpose.

Estimated technology readiness level (TRL) range at beginning and end of contract

- 2
- 3

PARALLEL NONLINEAR OPTIMIZATION FOR ASTRODYNAMIC NAVIGATION

CU Aerospace, LLC

2014 Phase I
H9.04-9769

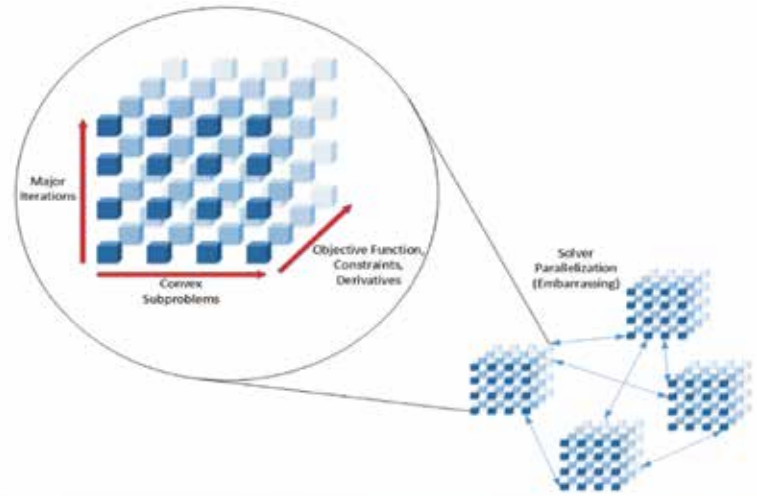

Identification and Significance of Innovation

Existing trajectory optimization tools (such as OTIS, EMTG, and MALTO) rely on black box nonlinear programming (NLP) problem solvers such as SNOPT, IPOPT, and WORHP. These solvers execute their code in serial and are acting as runtime bottlenecks in many applications. CU Aerospace proposes a new ground-up parallel NLP solver to replace the current solvers for use with all existing NASA trajectory optimization solvers. Inherent parallelism will be added at four levels: the major-iteration, the convex subproblem, the linear algebra, and the derivative calculation. These changes should lead to orders of magnitude speedup, while also offering a massive maximum possible parameter space. The software will be as architecture agnostic as possible, so that it scales from Supercomputers, GPU processors, and hybrid machines, down to single multicore chips on desktop machines. Finally, the interface options for this tool will be compatible with the existing NASA software that would utilize it.

Estimated technology readiness level (TRL) range at beginning and end of contract

- 3
- 5

Technical Objectives

Early Phase I will comprise researching existing parallelization techniques in more detail and identifying the most promising approaches for parallelization at each level. In the second half, prototypes of both MPI- and GPU-based parallel derivative calculation will be implemented, and the speeds compared. Additionally, a prototype NLP solver that parallelizes at the Major-Iteration level, while running the convex subproblem in serial, will be used to identify the baseline outer-loop speedup techniques. Similarly, a convex subproblem parallel approach, using a serial outer loop, will be used to baseline the internal speedups. Finally, a test case using standard trajectory optimization formulation will allow tuning the prototypes towards the target problem type. Phase I will end with the software specification for the full solver and make strong recommendations for the parallelization approaches to be used in Phase II.

NASA Applications

This tool will have immediate applications to NASA as a plug-in to existing, in-use trajectory optimization software such as OTIS, EMTG, and MALTO. This solver will be designed from the ground up to be especially efficient at trajectory optimization problems; however, it will be equally applicable to optimization in other fields, including aerodynamics and engineering design.

Non-NASA Applications

A rapid, nonlinear optimization solver has appeal across both academic and commercial markets. Many existing companies and research groups already use NLP solvers and would welcome one that can take advantage of low-cost GPUs while also scaling to supercomputers, reducing their time-to-solution. This has applications to: economics, engineering, finance, agriculture, among other fields.

PARALLEL ENHANCEMENTS OF THE GENERAL MISSION ANALYSIS TOOL (GMAT)

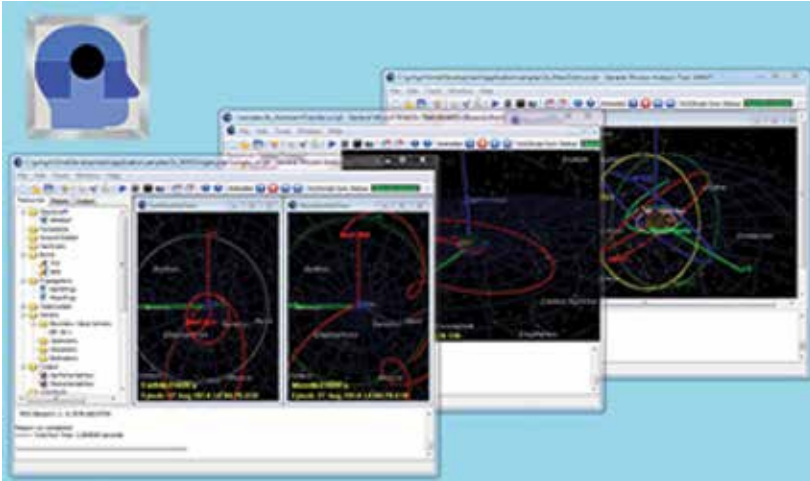

Thinking Systems, Inc.

2014 Phase I
H9.04-9856

Technical Objectives

Objective: Implement a version of GMAT that uses parallel processing to efficiently run on modern, multicore computers. In phase I, Thinking Systems will

- Design the parallelization framework for GMAT
- Implement GMAT engine components for parallel simulation runs
- Implement GMAT commands and resources for parallel processing
- Build a basic user interface (UI) around these components
- Port the TSPlot plotting package into the UI
- Demonstrate two capabilities:
 - Simultaneous simulation runs running concurrently
 - Computation of parallel Finite Differencing in GMAT Targeting

Phase II work will extend these capabilities to other features of GMAT.

NASA Applications

- Capitalizes on evolving computer hardware on Linux, Mac, and Windows systems
- Scales for launch window analyses, dispersion analyses, large-scale targeting problems, and precision propagation of many objects simultaneously

Non-NASA Applications

- Cross platform capability addresses an identified industry need
- Inclusion of proven GMAT features addresses the need for an extensible proven space mission design tool

Identification and Significance of Innovation
GMAT is a state-of-the-art spacecraft design tool. GMAT's architecture was designed to support multiple parallel runs of simulations, but the parallel processing design features have not been implemented (GMAT runs on a single processing thread even when multiple cores are available).

Thinking Systems will

- Produce an efficient parallelization of GMAT's capabilities by implementing the parallel processing design features.
- Code parallel processing components that plug into GMAT to exercise the parallel processing capabilities of the tool.

The resulting system will enhance GMAT's capabilities for parametric studies, Monte Carlo analysis, large-scale targeting, and dispersion analysis.

Estimated technology readiness level (TRL) range at beginning and end of contract

- 1
- 3

NAVIGATION TECHNOLOGY SBIR PHASE II AWARDS

2005 TO 2012



Early celestial navigation tool: Sextant

X-RAY PULSAR-BASED NAVIGATION AND TIME DETERMINATION

Microcosm, Inc.

2005 Phase II
01.02-9013

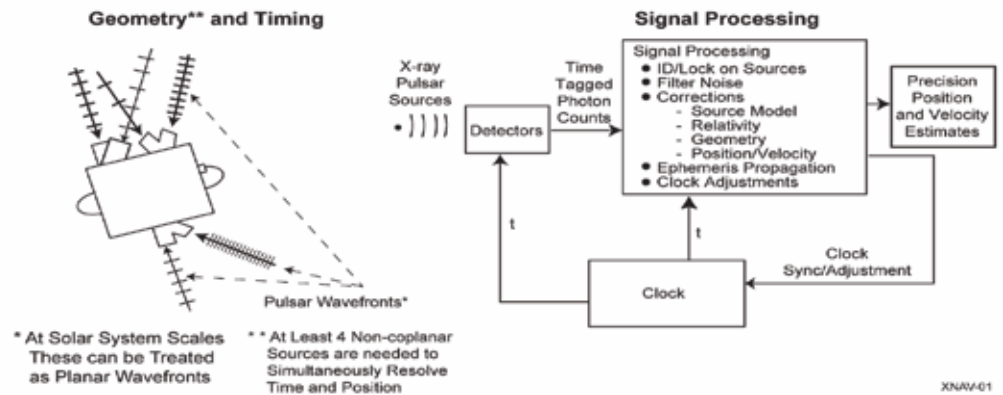

Identification and Significance of Innovation
Celestial x-ray source-based navigation and timing (XNAV) holds great promise for NASA because it is an enabling technology for fully autonomous interplanetary navigation and would provide significant mission enhancements as an adjunct to the Deep Space Network (DSN) and ground-based navigation methods. XNAV has the potential to greatly enhance system autonomy, while driving down DSN operations and infrastructure costs. Traditional XNAV uses observations of the x-ray emissions of highly stable, rotation-powered, millisecond pulsars as a kind of “natural GPS” signal. Accurate pulse time-of-arrival estimates from four or more noncoplanar sources allows simultaneous determination of both position and time autonomously anywhere in the solar system. In addition, brighter, less stable x-ray sources may have utility as well, particularly in relative navigation applications.

Phase I demonstrated achievable XNAV accuracy, developed a preliminary source catalog, constructed an XNAV error budget, and laid out potential implementation options for XNAV. Phase II will develop a detailed XNAV simulation to evaluate XNAV performance for missions of interest, and specifically to develop an XNAV flight experiment software package that can be flown on a near-term demonstration mission.

Technical Objectives

- Assess navigation requirements and perform systems engineering for a specific demonstration mission
- Develop the XNAV algorithms for interplanetary missions
- Create a detailed XNAV simulation in the GSFSC GPS-Enhanced Onboard Navigation Software (GEONS) environment

Run simulation for mission of interest/perform trade studies

- Transition simulation code into a flight experiment package ready for flight on a near-term demonstration mission
- Create an interagency XNAV working group to take advantage of parallel XNAV development efforts between NASA and Department of Defense (DoD)

Work Plan

- Task 1—Requirements Definition and Systems Engineering
- Task 2—XNAV Algorithm Development
- Task 3—XNAV Simulation Development/Trade Studies
- Task 4—Flight Experiment Software Development

NASA Applications

XNAV is principally applicable to NASA interplanetary missions—regions beyond the range of GPS that currently rely on the DSN for navigation. It can provide autonomous navigation throughout the solar system, greatly reducing demands on the DSN. It can augment the DSN by providing accurate time synchronization and position and velocity components normal to the line-of-sight to Earth to enable faster and more accurate navigation solutions. It can enable fully autonomous navigation for missions beyond Jupiter, potentially improving on DSN performance for very far interplanetary missions. XNAV can enable spatially and temporally coordinated measurements over solar system scale distances, enabling or enhancing multispacecraft interferometer missions.

Non-NASA Applications

Primary non-NASA applications are Department of Defense (DoD) missions. Specific applications include navigation beyond GPS range, backup navigation in the event of GPS denial, GPS reconstitution, and development of a super synchronous navigation and time distribution service. XNAV could be viable for autonomous navigation and station keeping for geostationary Earth orbit (GEO) satellites.

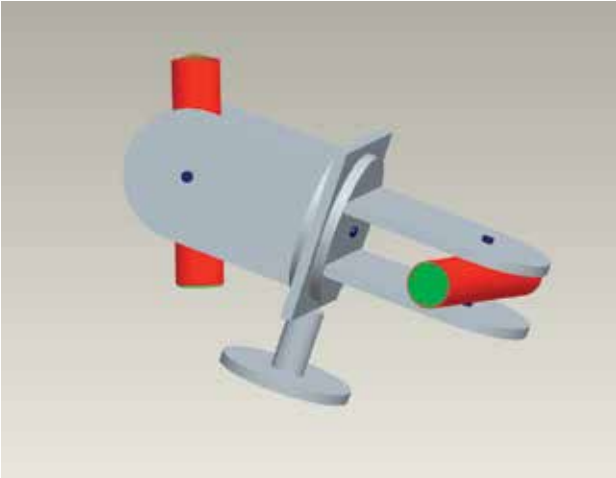

Technical Objectives

Phase I resulted in the design of the deep space sensor hardware with supporting analysis and a complete deep space navigation simulation delivered to NASA using Princeton Satellite Systems (PSS) VisualCommander product.

Work Plan

In Phase II the TQS will be prototyped and tested at Princeton University. The navigation simulation will be updated with high-fidelity sensor and disturbance models and will be expanded to include lunar ephemerides for all planets. The navigation software will be expanded to include sensor tracking control, target identification, and telemetry and command functions ported to the sensor onboard processor.

NASA and Non-NASA Applications

This sensor and navigation system are applicable to NASA and European Space Agency (ESA) deep space missions. It is particularly well-suited to solar sail and other low-thrust missions, which require continuous navigation or that cannot use external signals. Other applications include lunar surface navigation. Potential NASA, Air Force, and ESA missions have been identified.

Identification and Significance of Innovation

A new deep space navigation sensor called the Twin Quad Sensor (TQS) that uses Sun chord widths, angles between planets, and angles to stars has been developed. This sensor is combined with a new navigation filter using an Unscented Kalman Filter which employs a fully nonlinear state propagator and nonlinear measurement equations. The nonlinear state propagator includes a full solar system gravity model, a solar pressure model, and a thruster model. The filter can utilize measurements from the optical sensor or from the Deep Space Network.

NOVEL GPS-BASED ATTITUDE (GPS/A) SYSTEM FOR LAUNCH VEHICLES

Toyon Research Corporation

2007 Phase II
01.03-9524

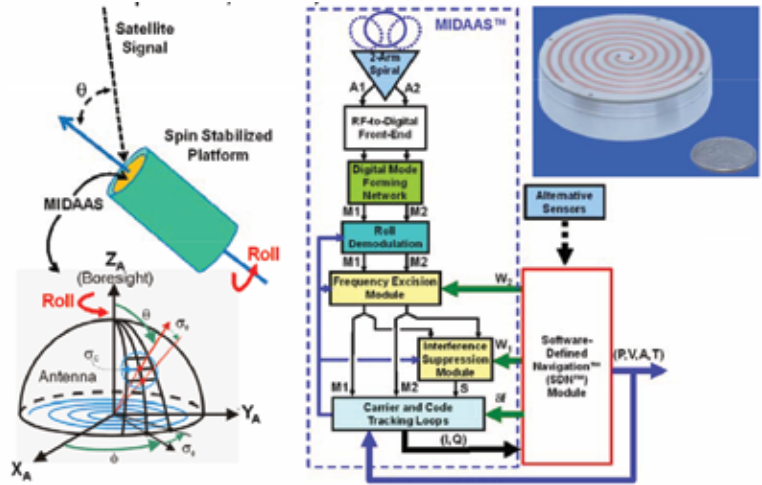

Identification and Significance of Innovation

- MIDAAS is Miniature Integrated Direction-finding Attitude determining Anti-jam System
- Innovative antenna/receiver design reduces size and complexity of three-dimensional (3-D) GPS-based attitude systems
- 3-D attitude for spinning platforms with a small single-aperture antenna and two radiofrequency (RF) channels
- Open-source GPS software-defined receiver (SDR) minimizes development cost and time and long-term system upgrade costs
- Anti-jam capability in each MIDAAS unit
- Ultra-tightly coupled GPS-based attitude receiver
- System performance was demonstrated with hardware during Phase I effort. Current TRL: 3 to 4

Expected technology readiness level (TRL) range at the end of contract

- 7

Technical Objectives

Design, develop, build, test, and demonstrate a stand-alone real-time prototype GPS-based attitude sensor on an actual spin-stabilized launch platform.

Work Plan

- Incrementally modify Phase I non-real-time breadboard to a real-time configuration
- Migrate algorithms to real-time breadboard system
- Design stand-alone prototype using same architecture as real-time breadboard
- Migrate breadboard algorithms to prototype system
- Test and demonstrate real-time prototype

NASA and Non-NASA Applications

- GPS-based attitude determination for launch vehicles
- Zero-drift attitude system for unmanned/micro air vehicles unmanned air vehicles (UAVs) and micro air vehicles (MAVs)
- Spin-stabilized munitions and civil aviation industry
- Navigation aid for hand-held GPS receivers and landrobots
- Orienting device for recreational and virtual reality systems

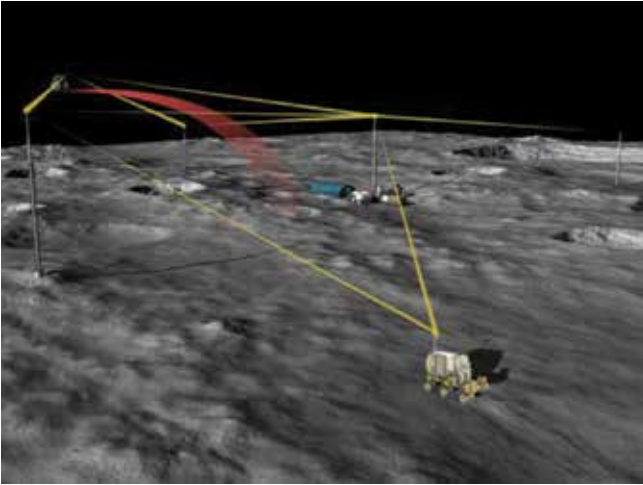

Technical Objectives

- The objectives of Phase II will be to fully develop and demonstrate our concept of a precision, scalable lunar surface navigation system.
- The following tasks define the summary objectives for Phase II:
 - Establish key performance requirements
 - Prototype multinode wireless network employing Point-to-Point (PTP) for demonstration
 - Complete electronics design and identification of components
 - Complete design of radiofrequency (RF) transmit, receive, and antenna components and develop link models for the lunar environment
 - Complete tower design with FEA and fabricate a scale model
 - Demonstrate trilateration processing in prototype wireless network
 - Deliver prototype hardware and firmware

NASA and Non-NASA Applications

- System will be used primarily in planetary habitation, exploration, and mining but also has applications in landing systems for lunar, terrestrial, or Mars reentry.
- The same technology may be used to perform these functions with only minor modifications during future planetary exploration.
- Modernization of the aging international LORAN infrastructure with a lower power, more-accurate digital solution. LORAN remains a critical navigational aid for merchant ships, especially in port ingress during heavy storms where GPS is not available.
- Modernization of air traffic control systems with a highly precise and reliable air traffic and runway monitoring system. The integration of the Precision Time Protocol with the Sensis MDS product will improve accuracy and useful range as well as reducing cost and complexity.

Identification and Significance of Innovation

- Establishes a high-precision navigation system that can scale seamlessly to any size, allowing any number of mobile or fixed nodes in the network
- Integrates proven technologies to provide an innovative solution to lunar navigation while naturally supporting data and voice communications on the same network
- Provides a precise and reliable navigation backbone to support traverse-path planning systems and other mapping applications and establishes a core infrastructure for long-term occupation
- Proposed tower network with trilateration provides the least technological risk, employing proven physics and navigational measurement techniques coupled with recent advances in precision network time synchronization

Expected technology readiness level (TRL) range at the end of contract (1–9)

- 5 to 6

TRACKING LAUNCH VEHICLES IN INTERFERENCE AND JAMMING

MARK Resources, Inc.

2008 Phase II
04.01-9264



Identification and Significance of Innovation

In Phase I, MARK Resources developed a method to combine a set of distributed FRPAs into a network that provides high GPS anti-jam/interference capability, and demonstrated it via software simulation. The individual antennas need not be precisely located relative to one another. The system is compatible with existing GPS antennas and receiver hardware, operates on the C/A code, and has a small processing load. It will make GPS metric tracking robust against jamming and interference, hence effective for range safety.

Expected technology readiness level (TRL) range at the end of contract (1–9)

- 4 to 5

Technical Objectives

The technical objective of Phase II is to develop a demonstration unit consisting of launch-compatible antenna and receiver hardware plus processing software; and to measure its performance using a high-fidelity radiofrequency (RF) simulation.

Work Plan

- Refine Phase I Algorithms
 - Jammer suppression and orientation determination
- Measure performance on intermediate-frequency (IF) software simulation
- Assemble demonstration unit
- Measure performance on RF simulation
- Determine implementation requirements
- Develop transition plan

NASA Applications

GPS metric tracking of Ares and other launch vehicles; autonomous flight safety system; and space-based range certification and demonstration project.

Non-NASA Applications

Common Range Integrated Instrumentation System; Small Diameter Bomb; A-160 Humming Bird helicopter; High Altitude Long Endurance (HALE) aircraft; and Scan Eagle UAV.

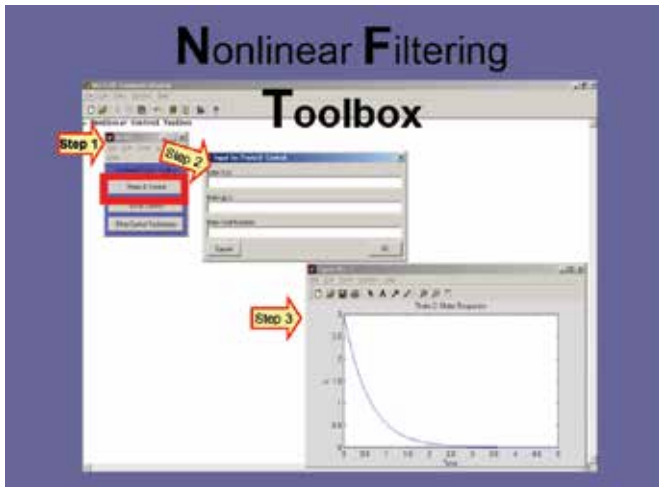

Technical Objectives

- Robust accurate estimation and observability
- Direct model uncertainty estimation
- Multiple sensor suites
- TRL 2 to 3 during Phase II

NASA Applications

- The algorithms and MATLAB based filtering toolbox will be a valuable asset tool for NASA's orbit determination technologies.

Non-NASA Applications

- Educational institutions for teaching estimation and orbit determination, aerospace companies, and automotive industries during design phase.

Identification and Significance of Innovation

O-D, CBF, Neural Network Estimator Algorithms

- Nonlinear filtering methods
- More accurate than linearized methods
- Computational Efficiency
- Methods focus on accuracy and efficiency
- Nonlinear Filtering MATLAB Toolbox

Technology readiness level (TRL) during Phase II

- 2 to 3

CONTINUATION METHODS AND NON-LINEAR/NON-GAUSSIAN ESTIMATION FOR FLIGHT DYNAMICS

Numerica Corp.

2009 Phase II
04.04-8416

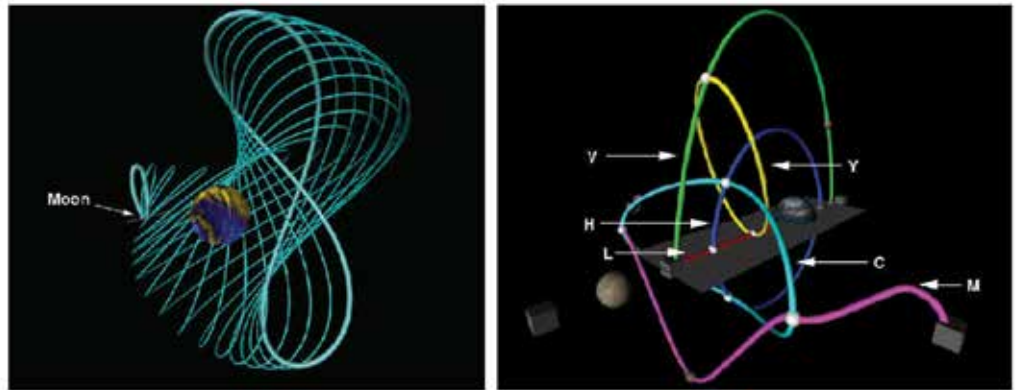

Identification and Significance of Innovation

The proposed research will make powerful ideas from dynamical systems available to the space mission designer.

Specifically, we propose to augment current NASA mission design software with tools in the following suite of software:

- Continuation methods for generation of libraries of orbits, stable/unstable manifolds, and heteroclinic connections.
- Computation of continuously controlled trajectories that are optimal with respect to design cost function.
- Uncertainty propagation using advanced filtering and estimation.

Expected technology readiness level (TRL) range at the end of contract

- 4 to 6

Technical Objectives

- Implement all trajectory design tools developed during the Phase I effort into the General Mission Analysis Tool (GMAT) software. These include orbit generation, optimal control algorithms, and uncertainty management.
- Extend parameter continuation methods for computation of unstable manifolds and heteroclinic connections to act as scaffolding for mission design.
- Extend continuous optimal control for attitude control and formation flight scenarios.
- Develop state-of-the-art methods for estimation of orbit uncertainty and filtering of uncertain measurements.

NASA and Non-NASA Applications

The resulting software for trajectory design and uncertainty management will have immediate application in the following areas:

- Designing of NASA deep space missions for optimal fuel consumption and uncertainty mitigation.
- Space surveillance for tracking of space debris.
- Commercial satellite industry for control and tracking of satellites.

MULTIPURPOSE RADIO SIGNAL GENERATION SYSTEM FOR SPACE APPLICATIONS, SIMULATION, AND TESTING

Emergent Space Technologies, Inc.

2009 Phase II
04.02-8458

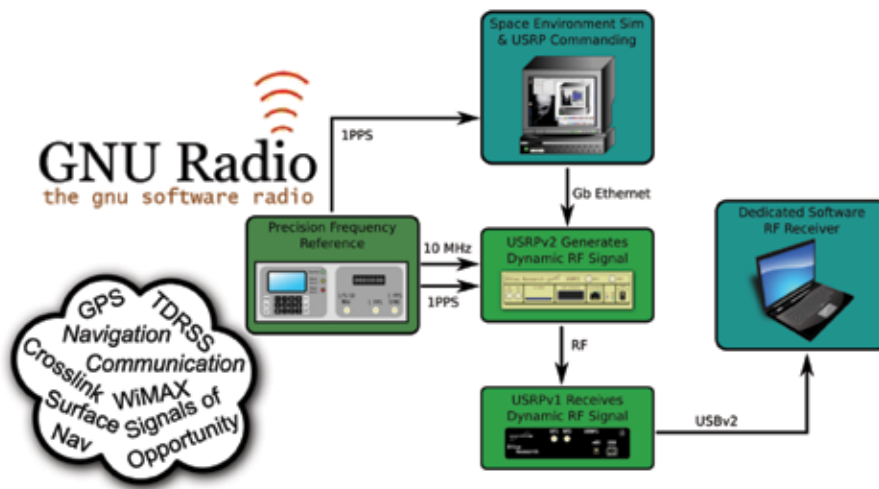

Technical Objectives

- Design and develop a simulator system, based on Phase I prototype that can generate all in-view satellite signals
- Retire risks inherent in design by building a functioning prototype
- Deliver working hardware to the Magnetospheric Multiscale (MMS), Geostationary Operational Environmental Satellite R-Series (GOES-R), or other ongoing missions

Work Plan

- System specification and design
- Multisatellite simulation in SDR
- Simulation fidelity enhancement (antenna gain, ionosphere, GPS yaw effects, and other error models)
- User interface development including closed-loop trajectory testing with General Mission Analysis Tool (GMAT)
- Integration and test

NASA Applications

- Real-time closed-loop simulations of GPS and crosslink hardware for complex Human Exploration and Operations (HEO) missions such as MMS and GOES-R
- Customizable waveforms to meet mission specifications

Non-NASA Applications

- Any commercial satellite in high Earth orbit using GPS
- Department of Defense space applications
- University lab environments

Identification and Significance of Innovation

Many upcoming space missions have very complex high Earth orbits that will present a challenge for the use of GPS as a primary source of navigation, though NASA has developed weak signal receivers that can accomplish this. Preflight testing and hardware acceptance become the problem since the GPS simulators used for these purposes are repurposed from terrestrial applications, and present difficulties for space-based testing. This work develops a simulator based on commercial-of-the-shelf (COTS) software-defined radio (SDR) technology that is designed from the start for space applications. A Phase I effort demonstrated generation of a single GPS signal with the SDR hardware. Complex models are added via an open software interface, returning the expertise required for simulation studies to NASA. The system can also simulate communication waveforms.

DEEP SPACE NAVIGATION AND TIMING ARCHITECTURE AND SIMULATION

Microcosm, Inc.

2009 Phase II
04.04-9179

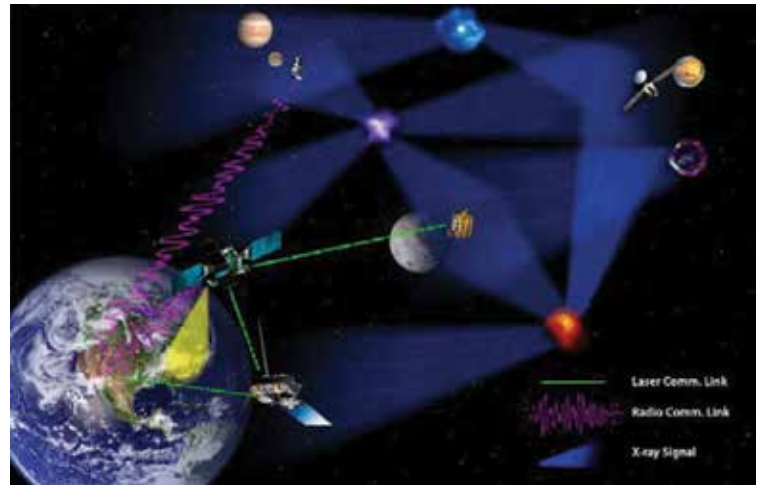

Identification and Significance of Innovation

The Microcosm team will complete the simulation tool architecture early in Phase II, and in parallel begin to develop the simulation. The tool is architected for carrying out performance analysis and rapid trade study assessments of competing navigation/timing architecture options for future NASA missions, incorporating state-of-the-art radiometric, x-ray pulsar, and laser communications measurements, among others, in the Orbit Determination Toolbox (ODTBX) environment. The solution centers on inclusion of a navigation layer as part of the communications architecture and on the maintenance and propagation of navigation states, time, and associated uncertainties onboard each platform with filtering capabilities enabling updates based on any available measurements. Such measurements include direct state and uncertainty updates via ground communication, radiometric- and lasercom-based range and range rate data from communication with ground stations and other spacecraft, time transfer from ground stations and other spacecraft, x-ray pulsar-based navigation and time measurements (XNAV), and others as they become available. This would be game changing for spacecraft autonomy—enabling platforms to operate using onboard state information rather than relying almost entirely on ground-based tracking and activity scheduling.

Expected technology readiness level (TRL) range at beginning and end of contract

- 2
- 6

Technical Objectives

- Architecture Development—Development of candidate navigation and timing system architectures incorporating new technologies, in light of current NASA plans as reflected in documents such as the Space Communications and Navigation (SCaN) roadmap.
- Simulation/Analysis Tool—Developing the detailed navigation/timing simulation capability in the ODTBX environment. Including new measurement types such as XNAV and LNAV, yielding overall system performance and ability to run rapid architecture trade studies.
- Testing and Validation—Develop use cases of interest to NASA and run the simulation, and compare results against other similar analyses run with existing mission performance and architecture assessment software tools.
- Performance Trades—After testing is complete, the new simulation tool will be employed to analyze navigation and timing network performance and capabilities for various key mission types.

Work Plan

- Task 1—Architecture Development
- Task 2—Simulation/Analysis Tool
- Task 3—Testing and Validation
- Task 4—Performance Trades

NASA Applications

The proposed navigation and timing architecture simulation tool will support evaluation of SCaN architecture concept and will enable mission planning for human exploration, and robotic and infrastructure missions for integrated SCaN architecture. XNAV, LNAV capabilities, ODTBX, and other existing analysis and assessment tools will enable enhanced navigation and timing solutions for next-generation Earth orbit to the outer solar system missions for NASA.

Non-NASA Applications

A key non-NASA application would be primary or secondary navigation and timing services for Department of Defense (DoD) missions. Commercial systems benefiting from XNAV and LNAV could potentially become future customers of the software being developed.

X-RAY DETECTION AND PROCESSING MODELS FOR SPACECRAFT NAVIGATION AND TIMING

Microcosm, Inc.

2009 Phase II
04.02-9182

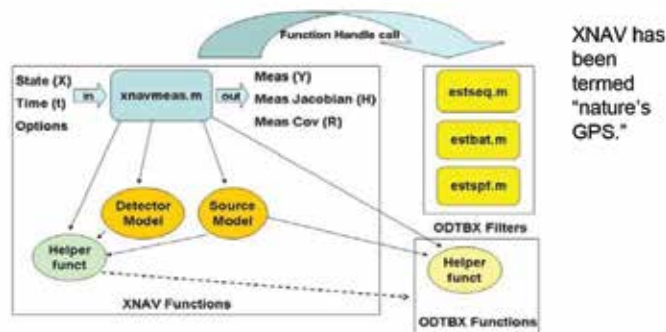

Highly stable pulsars can be viewed as “celestial lighthouses,” providing an oscillating signal with long-term stability comparable to current atomic clocks. These signals can be exploited to maintain accurate time and position in a way similar to existing deep space navigation systems. New algorithms will be developed in the ODTBX environment.

Technical Objectives

- ODTBX Simulation Development—Develop the XNAV simulation in ODTBX, continuing work started in Phase I, incorporating new photon processing algorithms.
- Photon Processing Algorithm Development—Develop refined XNAV algorithms for the estimation of spacecraft position, velocity, and time. Create initial detector model, improved source models for most relevant sources, to support end-to-end processing from x-ray photon detection to computing range measurements to navigation/time estimation.
- Demonstration/Validation—Use actual on-orbit data from previously flown x-ray detector missions to validate the photon processing algorithms through the simulation.
- Flight Software—Develop a flight experiment software package using the photon processing algorithms, validated with the ODTBX simulation.

NASA Applications

XNAV is a game-changing technology for NASA, enabling new missions, providing navigation autonomy and redundancy, and offering a path to reduce the scheduling demands on DSN, a valuable NASA asset. There are several promising NASA applications for XNAV where the improvements in navigational accuracy will either enable new missions or reduce their costs, including missions to the outer planets, and nonplanetary missions to deep space. Missions to Mars and the moon can take advantage of the autonomous navigation capabilities of XNAV, providing redundancy and reducing the need for regular DSN contacts, lessening the burden on this over-taxed system.

Non-NASA Applications

The primary non-NASA XNAV applications would be to provide primary or secondary navigation services for Department of Defense missions. For medium Earth orbit (MEO), geostationary Earth orbit (GEO), Human Exploration and Operations (HEO), and even cis-lunar missions, where GPS has limited availability, XNAV can provide primary autonomous navigation capability. In addition, XNAV could provide an essential backup navigation capability for missions that normally rely on GPS, but require continuity of operations in the event of loss or denial of GPS.

Identification and Significance of Innovation

In Phase II, x-ray source-based navigation and timing (XNAV) performance will be enhanced through the development of single-photon processing algorithms, which utilize all available photon time data to improve the accuracy of XNAV. A detailed model of the XNAV system, including single-photon techniques will be implemented in Orbit Determination Toolbox (ODTBX), increasing its functionality and providing a valuable mission design tool. ODTBX will be further refined by enhancements to detector and source models, including the addition of new pulsars. Time transfer and barycenter correction effects will be added. XNAV measurement types will include additional absolute range measurement types and range rate measurements. Functions developed for ODTBX will provide support for XNAV and XTIM studies including enhanced dynamic functions and linearized process models for inclusion of clock and other bias states; and performance prediction for the single-photon processing approaches. The team will work with Naval Research Laboratory (NRL), Johns Hopkins University/Applied Physics Laboratory (JHU/APL), and NASA Goddard Space Flight Center (GSFC), focusing on sources and detectors to develop improved models, and assessing timing accuracy. This work will further validate the utility of XNAV for NASA, and develop and test relevant new technology to provide a rapid path to full flight software development.

Expected technology readiness level (TRL) range at beginning and end of contract

- 3
- 6

ADVANCED BAYESIAN METHODS FOR LUNAR SURFACE NAVIGATION

Autonomous Exploration Inc.

2009 Phase II
04.03-9337

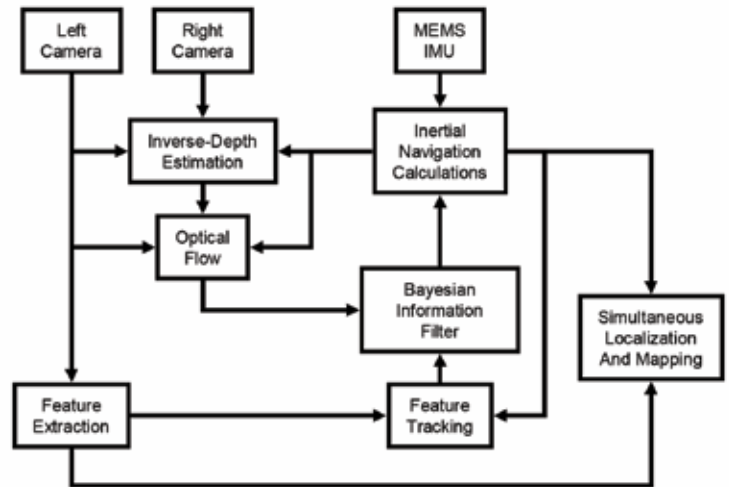

Identification and Significance of Innovation
Advanced Bayesian methods leverage current computing technology to produce a highly accurate surface navigation system. The system combines dense stereo vision and high-speed optical flow to implement advanced Bayesian Visual Odometry (BVO) that can accurately track faster rover movements. This will increase exploration productivity. BVO improves performance by using all image information, not just corner features. This improves performance in shadowed areas that yield only low-contrast images. High-speed, accurate BVO may enable the use of lightweight, low-power microelectromechanical system (MEMS) inertial measurement units (IMUs).

Expected technology readiness level (TRL) range at the end of contract

- Phase I: 3 to 4
- Phase II: 5 to 6

Technical Objectives

- Develop a brassboard prototype of a self-contained BVO system
- Demonstrate and test the prototype

Work Plan

- Task 1—Develop Better Ground-Truth Data
- Task 2—Improve and Enhance the BVO Algorithm
- Task 3—Transfer the Algorithm to a Real-Time Computer
- Task 4—Develop the Prototype Design
- Task 5—Construct the Prototype Module
- Task 6—Demonstrate and Test the Prototype

NASA Applications

- Speed and accuracy can make future rover missions more productive by enabling faster traverses.
- Lightweight and low power can help make it feasible to launch rover teams.

Non-NASA Applications

- Robustness can extend operation to areas where GPS is degraded or unavailable.

A LIGHTWEIGHT, MINIATURE INERTIAL MEASUREMENT SYSTEM FOR POSITION AND ATTITUDE ESTIMATION ON DYNAMIC PLATFORMS

Impact Technologies, LLC

2009 Phase II
04.05-9401

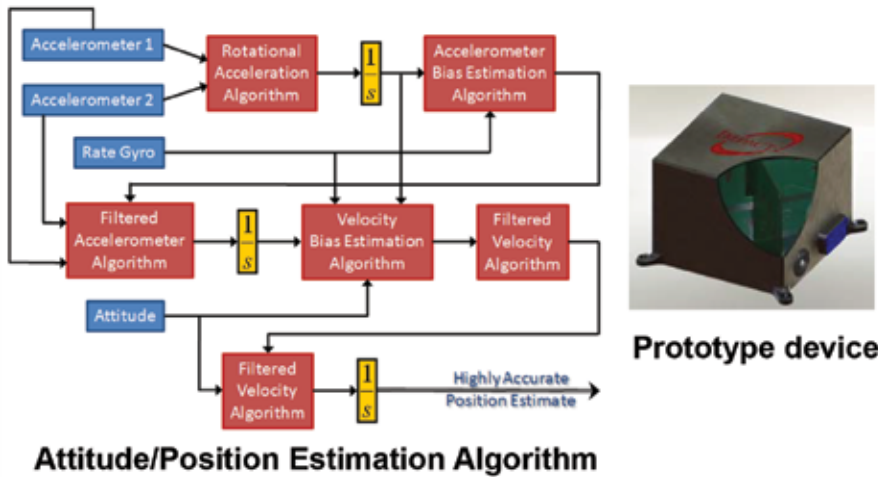

Technical Objectives

The objective of the proposed Phase II program is to develop and test a miniature attitude estimation prototype device coupled with acceleration measurements and a GPS receiver to provide highly accurate and stable inertial measurements and attitude/position estimates on highly dynamic platforms.

Work Plan

Specifically, this proposed project will perform the following tasks:

- (Quarters 1–4)—Attitude Estimation Algorithm Update and Improvements
- (Quarters 2–5)—Analysis of Miniaturization of Current Attitude Estimation Device
- (Quarters 3–6)—Simulation Testing and Update Including a Rocket Simulation and Detailed Sensor Models
- (Quarters 3–6)—Hardware and Prototype Fabrication
- (Quarters 5–8)—Laboratory Testing and Optional Prototype Testing in a Relevant Vehicle; Final Report; Tech Transition Activities

NASA and Non-NASA Applications

The successful completion of the proposed work will lead to improvements in the safe operations of general aviation aircraft, suborbital carriers and aerial/ground robots operated in GPS-denied locations. The proposed technologies with an emphasis on real-time attitude and position estimation will be directly applicable to low-cost attitude determination on suborbital carriers, inertial measurement estimation, reusable launch vehicles, and space-based range applications. It will lead to benefits in the form of improved reliability, accuracy, and sustainability of safety-critical aerospace systems.

Identification and Significance of Innovation

A current problem of Space-Based Range technology applications is the extensive cost and delays in mission launch operations. Due to the immense cost, and size of traditional INS and inertial measurement units (IMU), the development of a miniature low cost, weight, and power, highly accurate INS system that provides stable and highly accurate positioning and attitude measurements in the presence of highly dynamical motions is desired. Our new method focuses on identifying the gravitational vector to bound sensor drift errors to achieve a high degree of accuracy. By employing a revolutionary highly accurate, miniature estimation device that can be fused with traditional measurement systems and GPS to provide inertial measurements, the extensive cost, size, and redundancy issues that arise with conventional methods may be avoided.

DESENSITIZED OPTIMAL FILTERING AND SENSOR FUSION TOOL KIT

Analytical Mechanics Associates, Inc.

2009 Phase II
04.04-9465

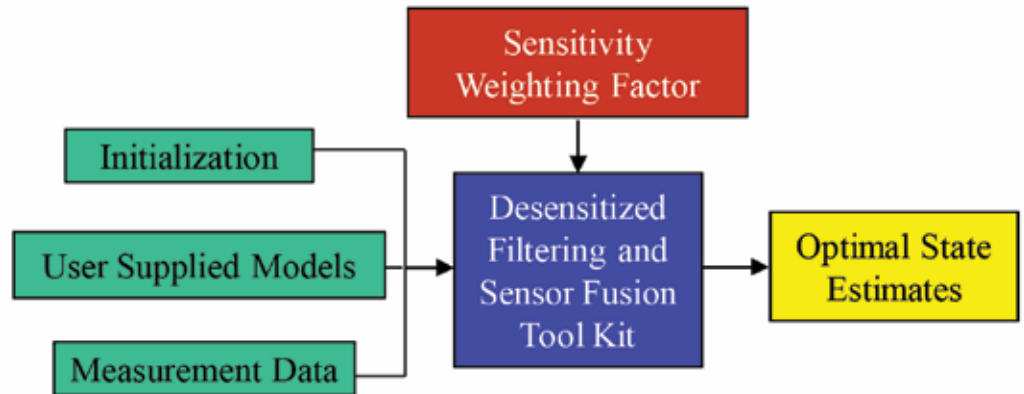

Identification and Significance of Innovation

- Develop new and innovative desensitized optimal filters for navigation and sensor fusion applications that are robust with respect to model uncertainties.
- Create a filtering and sensor fusion tool kit that implements the research results as well as recent advances in robust and/or adaptive filters for non-Gaussian problems with uncertain error statistics.

Technical Objectives

- Investigate approaches to reducing the sensitivity of the Kalman filter with respect to model parameter uncertainties
- Develop the detailed software design for the desensitized filtering and sensor fusion tool kit
- Integrate the tool kit modules with existing applications such as the GPS-Enhanced Onboard Navigation Software (GEONS)

NASA Applications

- Spacecraft and aircraft ground or onboard facilities to process navigational data from multiple sensor sources
- Analysis and testing of flight software and onboard data processing algorithms

Non-NASA Applications

- Marine vessel navigation, commercial airliner navigation, seismic data acquisition and analysis, and atmospheric observation data collection and processing

MICROELECTROMECHANICAL SYSTEMS (MEMS) GYROSCOPE WITH INTERFEROMETRIC DETECTION

Fine Structure Technology, LLC

2010 Phase II
04.01-9036

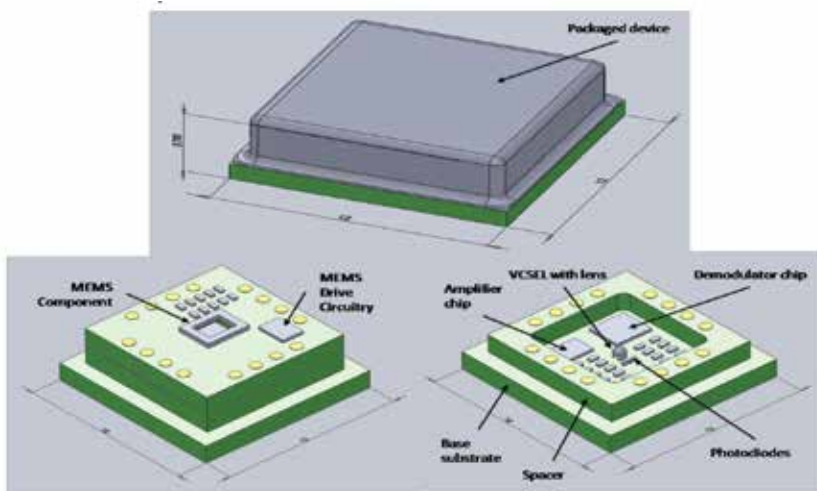

Technical Objectives

Technical Objectives: The phase I objective was to demonstrate a MEMS gyroscope using interferometric sensing to detect proof mass motions. The interferometric detector exceeded expectations and multiple gyroscope were successfully tested. For phase II, there are three objectives:

- Produce a low-cost, low-power MEMS gyroscope using interferometric sensing that meets the needs for NASA applications
- Deliver prototypes to NASA and other potential customers for evaluation
- Demonstrate that the gyroscope prototypes have acceptable performance

Work Plan

- Redesign MEMS for optimal performance
- Fabricate MEMS
- Electronics design
- System assembly
- Testing of prototypes 1a, 1b, and 1c
- Results evaluation and selection of optimal design
- Redesign MEMS based on test results
- Fabricate MEMS
- Electronics design and packaging
- System assembly
- Testing of prototype 2

NASA Applications

Metric tracking of launch vehicles, on-orbit navigation for spacecraft, and stabilization for space telescopes

Non-NASA Applications

Personal navigation systems, automobile navigation systems, precision drilling navigation for petroleum and mining, tactical navigation for small unmanned air vehicles (UAVs), and advanced interfaces for consumer products (cell phones and video games)

Identification and Significance of Innovation

The innovation is a MEMS gyroscope that uses an interferometric sensing technique to create a rate sensor with high sensitivity and performance stability comparable to that of fiber optic gyroscopes. The significance of the innovation is that it will

- Produce a small, low-power, and inexpensive MEMS-based rate sensor that improves the performance of metric tracking hardware when operating in an environment with unreliable GPS signals
- Enable tactical-grade navigation in small unmanned vehicles
- Enable personal navigation systems in consumer electronics
- Enhance petroleum drilling and mining operations by improving wellbore navigation during directional drilling

Estimated technology readiness level (TRL) range at beginning and end of contract

- 4
- 6

MINIATURIZED RADIATION HARDENED BEAM-STEERABLE GPS RECEIVER FRONT END

Tahoe RF Semiconductor, Inc.

2010 Phase II
04.02-9042

Proposed GPS RFIC Improves SWaP by 30X

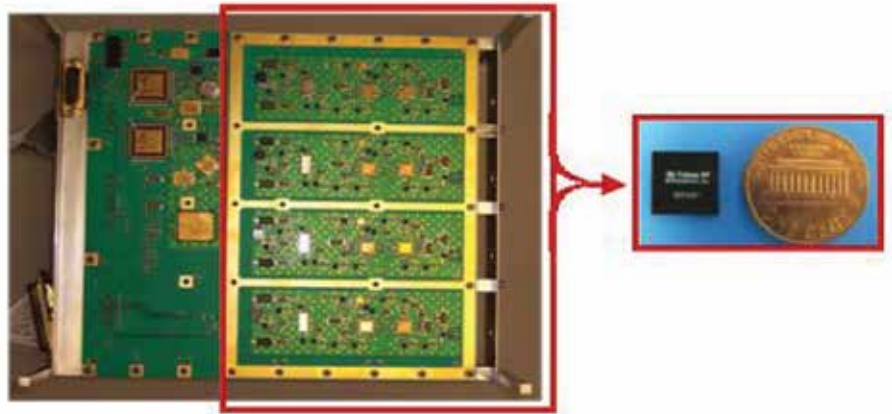

Identification and Significance of Innovation

It is expected that over the next two decades approximately 95 percent of all space missions will use GPS service for PNT (positioning, navigation and timing) capability. GPS receivers will be “embedded” in most instruments and will require improved size, weight, and power (SWaP), increased sensitivity and improved tolerance from large interferers and/or ruggedness to multipath errors. Current implementations are discrete, bulky, and power hungry.

The radiofrequency integrated circuit (RFIC) proposed here will have four coherent GPS receivers integrated onto a single silicon die providing the function of a multichannel GPS RFIC. The IC will be radiation tolerant using radiation hardened by design (RHBD) techniques developed at Tahoe RF Semiconductor (TRFS). The IC will provide the following enhanced performances: (1) improved sensitivity, (2) beam steering, (3) interference tolerance, and (4) signal recovery in multipath environment.

Estimated technology readiness level (TRL) range at beginning and end of contract

- 3
- 4

Technical Objectives

- Update RF system design for SiGe IBM 8HP process
- Design and fabricate four channel GPS receiver IC
- Achieve radiation tolerance using RHBD techniques
- Improve SWaP metric of the GPS receiver by >30 times
- Design and fabricate bench-level evaluation board
- Demonstrate the GPS RFIC performance in lab

Work Plan

- Update GPS RFIC system design
- Complete system design and analysis with improved performance
- Complete the design of GPS RFIC—Design and implement GPS RFIC including circuit design, simulations, and layout. Hold PDR, CDR, and FDR with NASA
- IC Fabrication and Board Design and Fabrication—Submit IC for fabrication at IBM. Design and fabricate evaluation board
- Bench Evaluation—Test and verify GPS RFIC on the lab bench; submit reporting

NASA Applications

Tahoe RF Semiconductor GPS RFIC solution will provide NASA with a compact, beam steerable low-power solution that can be deployed in all spacecrafts including small satellites. A partial list of potential NASA applications to benefit from GPS IC:

- International Space Station
- Magnetospheric Multiscale Mission
- COSMIC II Missions
- Jason III Mission
- Tracking and Data Relay Satellite System (TDRSS) Augmentation Service for Satellites (TASS)

Non-NASA Applications

TRFS GPS IC will show improved dynamic range, beam steering, interference tolerance to multiple paths and reduced power consumption. Target markets are

- PNDs (Personal Navigation Devices)
- Precision GPSs for surveying and agriculture
- In-vehicle navigation systems
- Telematics (asset tracking, and inventory management)

TRACKING AND DATA RELAY SATELLITE SYSTEM (TDRSS) AUGMENTATION SERVICE FOR SATELLITES (TASS)-ENHANCED NEAR-EARTH NAVIGATION SYSTEM

Emergent Space Technologies, Inc.

2011 Phase II
04.02-8761

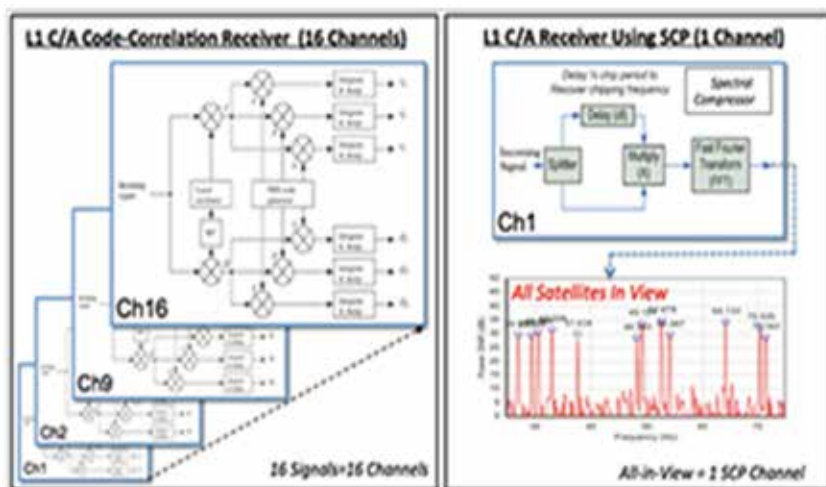

Technical Objectives

- Develop TASS/GPS waveform
- Port to commercial-off-the-shelf software-defined radio with direct path to space qualification
- Develop radiofrequency (RF) front end capable of handling both GPS and TDRSS signals
- Create and test a benchtop prototype to demonstrate the entire system

NASA Applications

Tracking and control of launch vehicles for placing payloads into orbital or suborbital trajectories. Precision inertial feedback during orbital maneuvers or stationkeeping operations on manned or unmanned spacecraft. Actively stabilize instrument platforms during sensitive astronomical observations or scientific measurements.

Non-NASA Applications

TENENS meets Department of Defense needs for positioning in orbits where conventional GPS is difficult or where GPS is denied. The system is low-SWaP, has a small footprint, and can be implemented in a software-defined radio platform. This makes it useful for applications in operationally responsive space. Commercial applications include missions in which highly accurate positioning is needed.

Identification and Significance of Innovation

This proposed effort heavily leverages multiple technologies that have been developed throughout NASA over the past 25 years to result in a low size, weight, and power (SWaP) autonomous precision navigation sensor for near-Earth operations. This same technology can also potentially be used for missions in various other orbital regimes. What is proposed here, and has been studied under Phase I, is a project known as the TASS-Enhanced Near Earth Navigation System (TENENS). It consists of a unique software GPS sensor which can exist in a very small footprint, and which makes use of NASA's GPS-Enhanced Onboard Navigation Software (GEONS) navigation software to process GPS measurements with TASS messages for greatly improved accuracy. TASS messages are already accepted by GEONS, but this effort will decode these for use with the navigation processor

Estimated technology readiness level (TRL) range at beginning and end of contract

- 5
- 7

ENHANCED PATH PLANNING, GUIDANCE, AND ESTIMATION ALGORITHMS FOR NASA'S GENERAL MISSION ANALYSIS TOOL (GMAT)

Decisive Analytics Corporation

2011 Phase II
04.03-9507

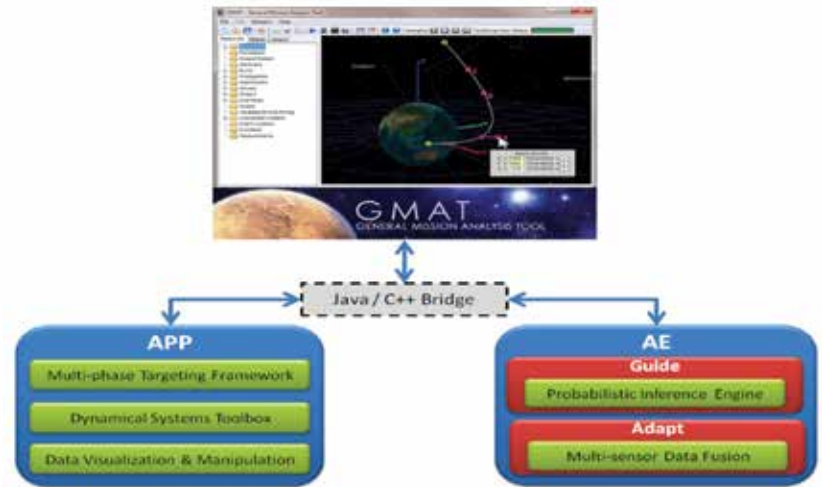

Identification and Significance of Innovation
Integration of Advanced Path Planning (APP) and Advanced Estimation (AE) capabilities into NASA's GMAT.

The APP plug-in will facilitate enhanced mission design capabilities that leverage concepts from dynamical systems theory, multiphase targeting algorithms, and data visualization and manipulation tools. This will offer a diverse toolbox of capabilities to study problems in multibody dynamics. The capabilities will support libration point mission design, but the modularity of the plug-in will allow for support of other classes of missions.

The AE plug-in will incorporate a powerful probabilistic inference engine and a multisensor data fusion framework. These include, but are not limited to, analysis of multimodal joint probability densities via Gaussian Mixture Models, sigma-point techniques such as Unscented Kalman Filters, and fusion of multiple measurements from noncollocated sensors.

Estimated technology readiness level (TRL) range at beginning and end of contract

- 4
- 8

Technical Objectives

Advanced path planning and estimation capabilities in complex nonlinear dynamical regimes represent two of the greatest technical challenges of modern spaceflight. The proposed Phase 2 work will focus on the refinement and augmentation of capabilities within the Phase 1 prototypes

APP plug-in development will generalize the targeting framework to accommodate a broader class of problems. It will also focus on the development and integration of a Dynamical Systems Analysis Toolbox and a visualization component to enable visual data manipulation. The combined capabilities will enable a dynamical systems approach for trajectory design in multibody regimes.

The AE plug-in development will be refined and augmented to exploit all the relevant functionality of Guide, a probabilistic inference engine, and Adapt, a multisensor data fusion framework. Both products were developed at Decisive Analytics under contract with various agencies within the Department of Defense.

NASA Applications

The APP plug-in will offer GMAT end users enhanced mission design capabilities in complex multibody regimes, such as the region near libration points or near small celestial bodies. The AE plug-in will offer GMAT end users estimation techniques that adequately characterize the effects of nonlinearities in the estimation process so they may effectively analyze, for instance, problems involving multimodal probability densities.

Non-NASA Applications

The APP plug-in includes a generalized multiphase targeting framework that is relevant to autonomous vehicle guidance in general. Furthermore, the AE plug-in is built around Guide and Adapt, tools built at Decisive Analytics under contract with the Missile Defense Agency and the U.S. Air Force. Any new developments integrated into the AE plug-in will ultimately also benefit our existing customers.

FRAMEWORK FOR THE DESIGN AND IMPLEMENTATION OF FAULT DETECTION AND ISOLATION

SySense, Inc.

2012 Phase II
H9.04-9443

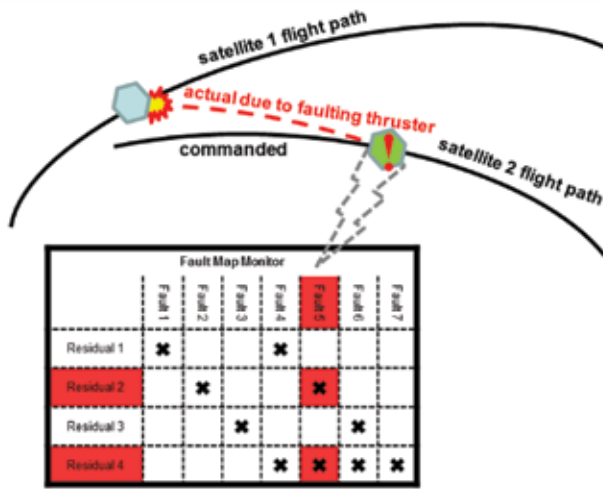

Technical Objectives

- Identify and quantify requirements of collocated and noncollocated FDI system.
- Develop concept of operation and design for collocated and noncollocated FDI algorithms
- Identify and quantify benefits of collocated and noncollocated FDI system
- Develop tutorial and tutorial material for mission designers

Work Plan

- Design collocated/noncollocated FDI system for sample mission.
- Test and validate sample mission FDI systems.
- Implement collocated FDI system in sample hardware environment.
- Implement noncollocated FDI system and GUI.
- Codify FDI tutorial materials and communication protocols.

NASA Applications

SySense, Inc.'s FDI methodology complements traditional system failure detection schemes and can provide additional safety and performance margins to any satellite or spacecraft mission. A clearly defined design framework will ease the burden of integration into existing and planned missions or systems.

Non-NASA Applications

SySense, Inc.'s FDI methodology complements traditional system failure detection schemes to provide additional safety and performance margins to any system that can be modeled, for example, power grids, and chemical refineries. A clearly defined design framework will serve as a marketing tool for the benefits and capabilities and to also ease the burden of integration into exiting or planned systems.

Identification and Significance of Innovation

Develop a framework for the design and implementation of fault detection and isolation (FDI) systems. The framework will define protocols for how FDI design should communicate with mission design and clearly define the types of information required to add capabilities to the mission.

The significance of this innovation is to expedite the integration of FDI technology into existing and planned missions with minimal additional burden to the mission designers.

Estimated technology readiness level (TRL) range at beginning and end of contract

- 4
- 6



COMPANY NAMES

Analytical Mechanics Associates, Inc.; Hampton, VA	25, 35, 62
ASTER Labs, Inc.; Shoreview, MN	40, 44
Autonomous Exploration Inc.; Andover, MA	23, 60
Broadata Communications, Inc.; Torrance, CA	13
CrossTrac Engineering, Inc.; Mountain View, CA	33
CU Aerospace, LLC; Champaign, IL	46
Decisive Analytics Corporation; Arlington, VA	39, 43, 66
Emergent Space Technologies, Inc.; Greenbelt, MD	18, 28, 37, 57, 65
Fine Structure Technology LLC; Austin, TX	31, 63
Impact Technologies, LLC; Rochester, NY	24, 61
IST-Rolla, Rolla, MO	15, 55
Keystone Aerospace; Austin, TX	38
MagiQ Technologies, Inc.; Somerville, MA.	36
MARK Resources, Inc.; Torrance, CA	12, 54
Micro-Space, Denver, CO.	22
Microcosm, Inc.; El Segundo, CA	5, 50
Microcosm, Inc.; Hawthorne, CA	20, 21, 27, 58, 59
Milli Sensor Systems & Actuators, Inc. ; West Newton, MA.	8
Nanohmics, Inc.; Austin, TX	10
Numerica Corp.; Loveland, CO	17, 56
Odyssey Space Research, LLC; Houston, TX	30
Optical Physics Company; Calabasas, CA	45
Payload Systems Inc.; Cambridge, MA	7
Perichoro LLC; Venice, FL	41
Physical Optics Corporation; Torrance, CA.	14, 34
Princeton Satellite Systems; Princeton, NJ	6, 19, 51
Progeny Systems; Manassas, VA	11, 53
SySense Inc.; El Segundo, CA	29, 42, 67
Tahoe RF Semiconductor, Inc.; Auburn, CA	32, 64
Thinking Systems, Inc.; Tucson, AZ	47
Toyon Research Corporation; Goleta, CA	9, 16, 52
Utopia Compression; Los Angeles, CA	26

SBIR POINTS OF CONTACT

James D. Stegeman
Technology Manager
Space Communications and Navigation Program
NASA Glenn Research Center
M/S 142-2
Cleveland, Ohio 44135
Telephone: 216-433-3389
E-mail: James.D.Stegeman@nasa.gov

Afroz J. Zaman
NASA Glenn Research Center
M/S 54-1
Cleveland, Ohio 44135
Telephone: 216-433-3415
E-mail: Afroz.J.Zaman@nasa.gov



