



Marshall Space Flight Center Digital Manufacturing

Engineering Solutions for Space Science and Exploration

The Digital Manufacturing capabilities located within Marshall Space Flight Center's (MSFC) Materials and Processes Laboratory provide various services that span the entire product life cycle. The Laboratory's three major digital manufacturing capabilities are manufacturing simulations, manufacturing execution systems (MES), and structured light scanning. Our manufacturing simulation tools focus on the design, development, and manufacture of a product, optimize manufacturing operations and identifying and correcting problems early in the lifecycle. Our MES tools offer configuration control of process plans, control work on the shop floor, and capture the as-built data record. Our structured light scanning tools allow for accurate 3D measuring of as-built parts, developing parametric models, producing machining methods and digital assemblies of as-built components. The group uses Model Base Engineering (MBE) to better integrate capabilities with the customer's needs. Where MBE defines & manages products & information through digital models, the group interfaces with MBE via the digital model's Product & Manufacturing Information (PMI). Using PMI the instruction for manufacturing and inspection can be embedded in the CAD model reducing lead time and waste. The Laboratory's digital manufacturing capability is dedicated to developing, improving, and delivering the advanced processes and digital solutions needed to meet NASA's various goals and missions.

Structured Light Scanning and Photogrammetry

Structured light scanning provides an accurate 3D surface representation of as-built hardware. This technique is capable of capturing parts less than 1 inch in length and, with the aid of photogrammetry, parts larger than 60ft in length. Photogrammetry uses images to capture 3D locations of reference points in space enabling the structured light capture of large hardware.

Structured light is used to perform inspections, reverse engineering, digital assemblies, match machining and manufacturing/process development. Inspections provide as-



Structured Light Scanning of hardware

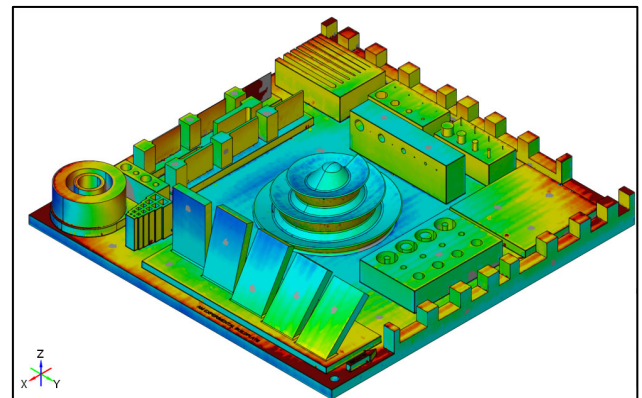

Comparison of As-Built to As-Designed Using Scan Data manufacturing/process development. Inspections provide as-designed/as-built comparisons, GD&T interrogations and comparisons of pre/post tested hardware. Reverse engineering allows for development of parametric CAD models from scan data. Particularly useful when hardware models are needed but do not exist or for interfacing with simulation studies. Manufacturing processes, like machining, can be directed by scan data e.g., machine paths can be derived from scan data and provided directly to a machinist. Digital assemblies provide a virtual assembly of hardware using only scan data. This is used to check for assembly issues such as mating surfaces or checking material thickness e.g., checking TPS pre/post application.

Digital Manufacturing

Our digital manufacturing tools provide a way to generate three-dimensional manufacturing simulations. Several analyses are performed that allow for problems to be identified early in the design cycle. Examples are as follows:

- Verification of facilities: Identification of process flow and assembly problems due to facility limitations.

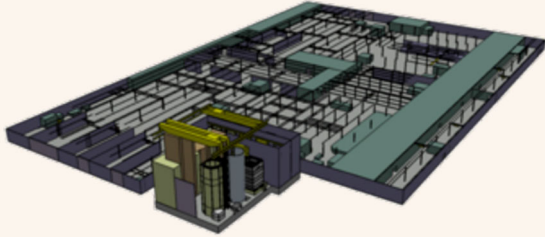

- Interference analysis:
 - Gain understanding of the interactions between tooling, fixtures, GSE, etc.
 - Simulate assembly processes and identify interferences.
- Kinematic verification:
 - Definition of complex kinematic mechanisms, up to nine degrees of freedom.
 - Determine through process simulations whether planned operations are kinematically feasible.
- Off-line robotic programming:
 - Optimization of robotic systems in an offline three-dimensional environment.
 - Deliver robotic programs to the manufacturing floor for execution.
 - Can include external axis such as rail and tower system or turntables.

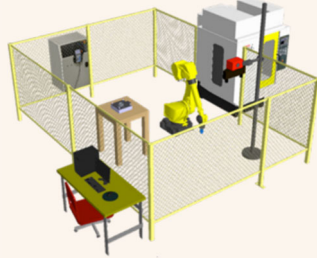

Manufacturing Execution System

When it is time to build or assemble parts on the shop floor, it is important to maintain configuration control of process plans and to capture all critical data that is used, generated, or created on the floor.



Our Manufacturing Execution System (MES) provides a very robust way to conduct process planning, process execution, and enforce process quality. This includes the following:

- Process planning:
 - Full configuration control of process plans.
 - Routing and approval of plans before they can be released to the shop floor.
 - eBOM to mBOM planning and reconciliation.
 - Allow planners to include rich instruction content such as CAD models, drawings, movies, documents, etc.
 - Effectivity assigned to plans (serial, lot, and date effectivity types).
 - Inclusion of model-based instructions (MBIs).
- Process execution:
 - Enforces that work is performed in the order/sequence defined by planning.
 - Captures as-built data such as serial number, lot number, temp, humidity, or any other process data.
 - Redlining of plans on the floor.
 - Provides method of superseding a work order with a later revision of a process plan.
 - Electronic buy offs.
- Process quality:
 - Discrepancy initiation, corrective actions, etc.
 - Allows for liens to be placed on parts.
 - Electronic quality buy offs.
 - Captures quality information from parts vendors.

For more information, please visit www.nasa.gov/centers/marshall/about/business.html

Contact:

Chad Hastings

EM42 Advanced Manufacturing Branch

MSFC Materials & Processes Laboratory

Email: william.c.hastings@nasa.gov

Phone: (256)961-1535

National Aeronautics and Space Administration

George C. Marshall Space Flight Center Huntsville, AL
35812 www.nasa.gov/marshall

FL-2013-12-145-MSFC G-28367

