

Mars Ion and Sputtering Escape Network (MISEN)

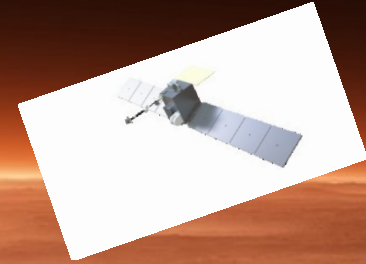
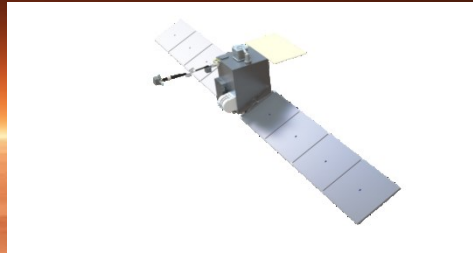
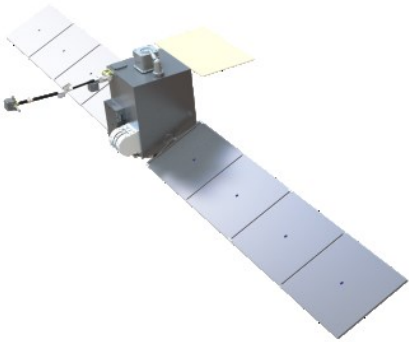

Rob Lillis¹, Jeff Parker², Shannon Curry¹, Jordi Puig-Suari³,
Christopher Russell⁴, Janet Luhmann¹, David Brain⁵

¹UC Berkeley Space Sciences Laboratory

²Advanced Space LLC

³Tyvak LLC

⁴UCLA Dept of Earth and Space Sciences

⁵University of Colorado, Boulder

Lunar and Planetary Science Conference,
March 18, 2017

Outline

- The Science Gap: why planetary aeronomy needs multi-point measurements.
- The MISEN Mission Concept for PSDS3
 - Science Objectives
 - Science Payload
 - Mission Design/Architecture
 - Mission ops & spacecraft
 - Mission Team

NOTE: two other similar competing missions for SIMPLEX-II: some details omitted

Plasma & magnetic field measurements in planetary environments: why do we care?

- Understand the structure, composition, variability and dynamics of planetary magnetospheres (e.g. MAVEN).

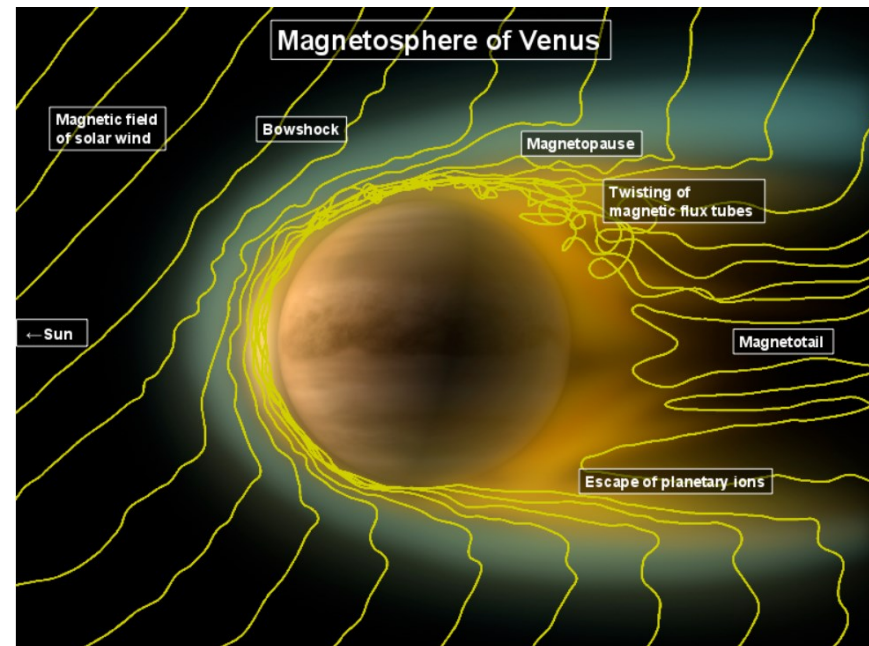
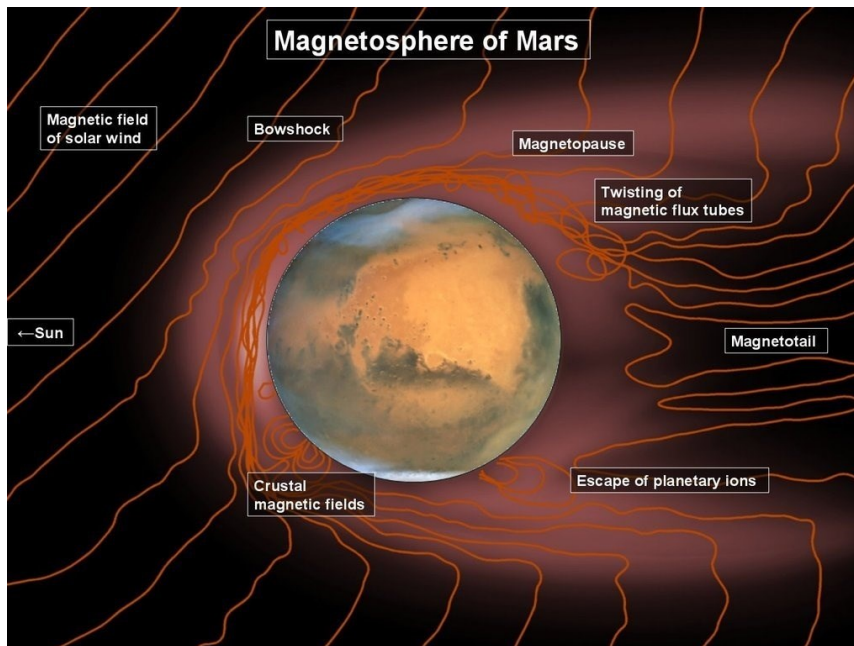

Plasma & magnetic field measurements in planetary environments: why do we care?

- Understand the structure, composition, variability and dynamics of planetary magnetospheres (e.g. MAVEN).
- Atmospheric Escape Processes: **ion** and **sputtering** escape are important for climate evolution of terrestrial planets

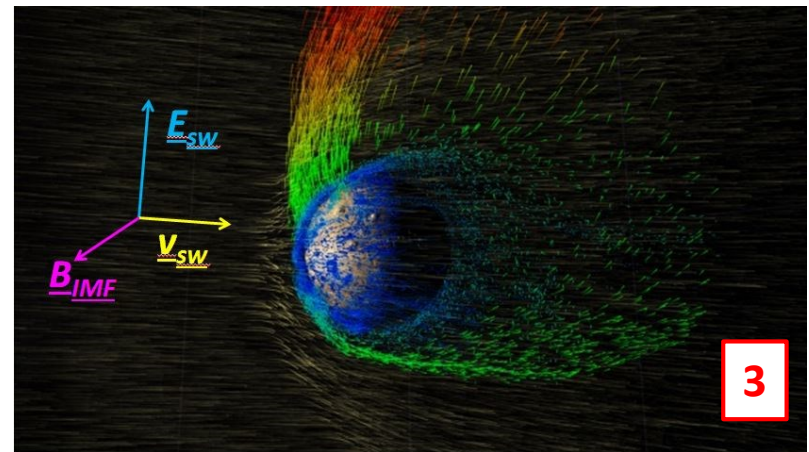
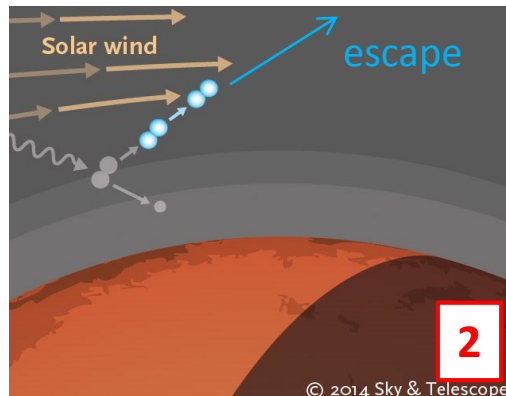
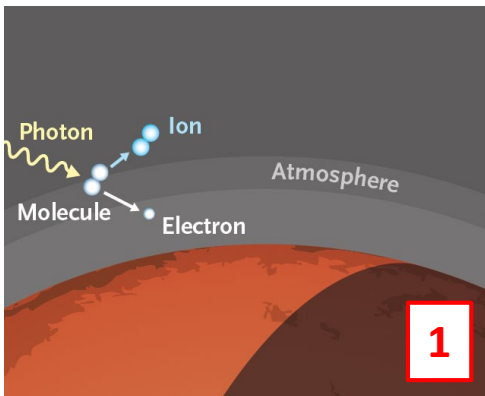

Pickup Ion
Escape

Plasma & magnetic field measurements in planetary environments: why do we care?

- Understand the structure, composition, variability and dynamics of planetary magnetospheres (e.g. MAVEN).
- Atmospheric Escape Processes: **ion** and **sputtering** escape are important for climate evolution of terrestrial planets

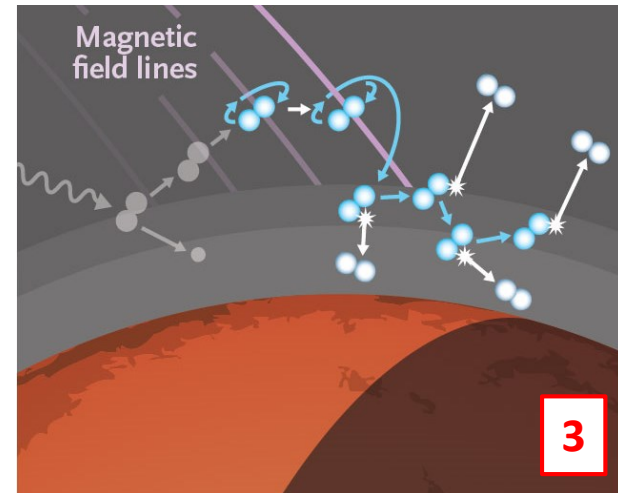
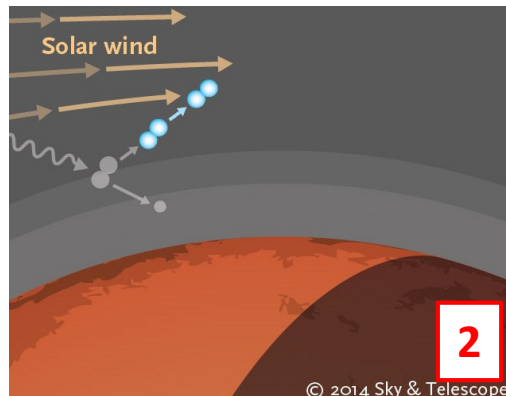
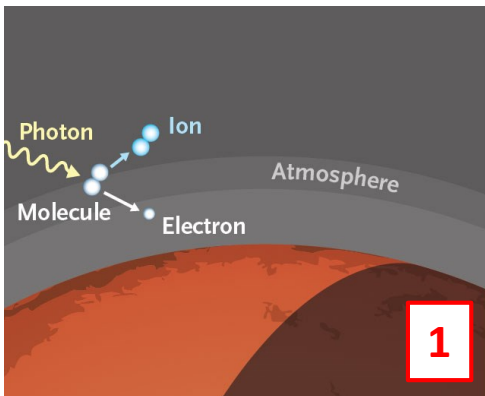

**Sputtering
Escape**

A single measurement platform leaves major questions unanswered

- spatial and temporal variations in escape fluxes cannot be distinguished
- responses of escape fluxes to changing solar wind conditions (~ 1 minute) can only be measured with a time-lag of an hour or (much) more
- global escape rate variability in response to space weather “storms” (much more common and intense in the early solar system) must be estimated (poorly) from a single orbit track.

MAVEN's precessing orbit

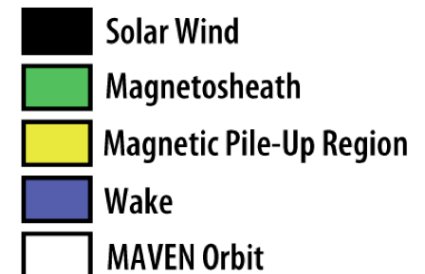
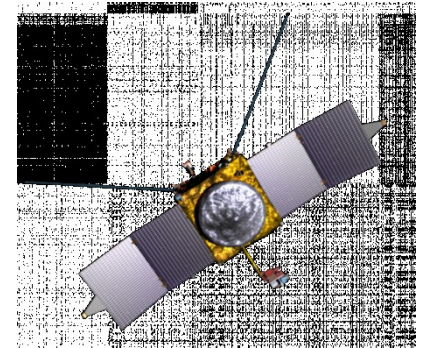
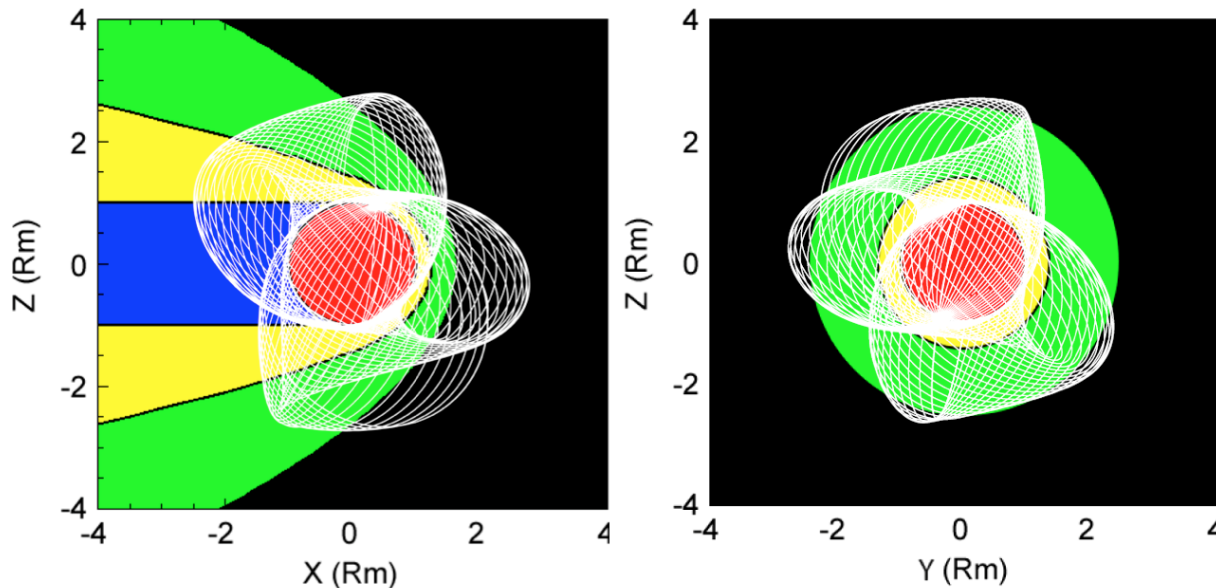

A Multi-spacecraft Revolution

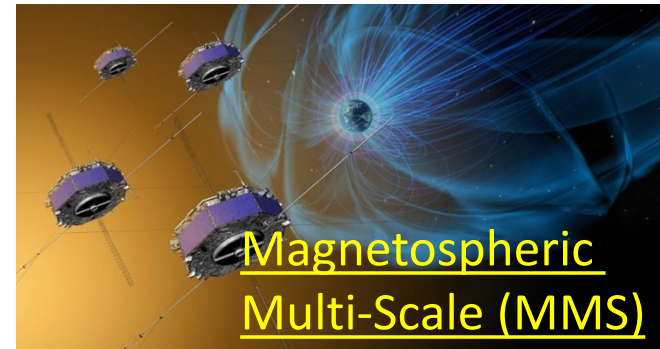
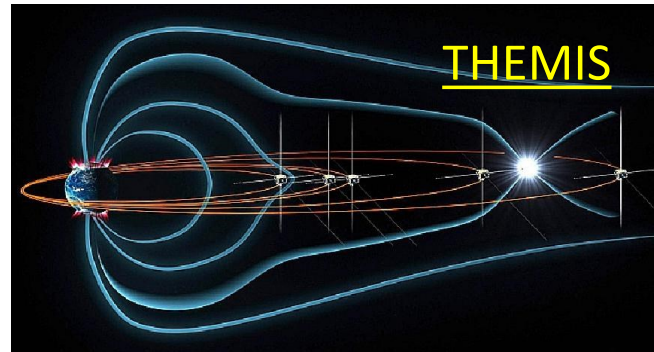

- The same problem faced terrestrial space plasma physics in the 1980s, early 1990s.
- Single spacecraft couldn't characterize plasma boundary dynamics.
- Multiple spacecraft allow the 3D, time-resolved measurements to create a realistic picture of the magnetosphere and how solar wind conditions affect it.
- Similarly, multiple spacecraft are the next step in understanding the solar wind interaction with unmagnetized bodies like Mars.



MISEN Objective and Concept

- Science Objective: Characterize the magnitude, structure and variability and real-time response to changing solar wind conditions, of ion escape and precipitation at Mars.

- In-situ measurements of ions, electrons and magnetic field.
- Three smallsats:
 - elliptical orbits ($\sim 250 \times 7000$ km)
 - Spaced in argument of periapsis, RAAN, and phased to ensure:
 - upstream solar wind measurements $>90\%$ of the time.
 - Simultaneous measurements of the different plasma regimes surrounding Mars.

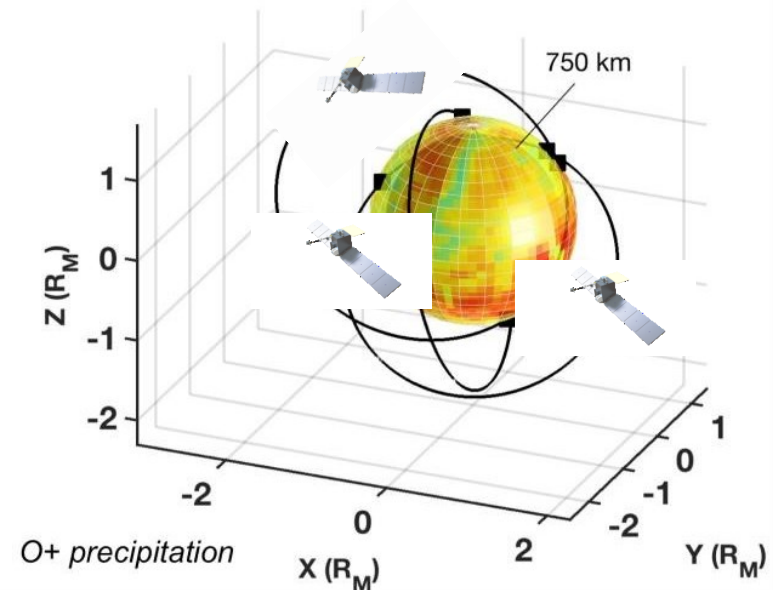

Science Payload

M-MAG (MISEN Magnetometer)

- Developed by UCLA (C. Russell)
- Clone of Insight Mars magnetometer
- Two mounted on boom (90 cm) i.e. gradiometer configuration
- 0.3U, 144 g, 0.8 W per sensor
- ± 8000 nT range
- 48 bits per readout up to 64 Hz

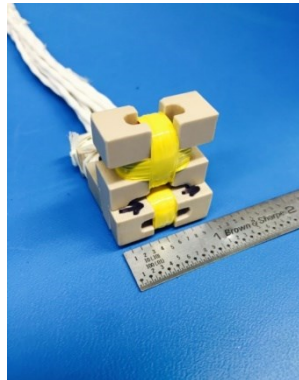

MESA (MISEN electrostatic analyzer)

- UCB/SSL heritage design, ion & electron analyzer
- 1.8 kg, 1.7 W.
- 4π FOV via spinning platform
- $22.5^\circ \times 6^\circ$, 3 eV-25 keV range
- DE/E = 18%
- Light-vs-heavy mass differentiation achieved through pulse height analysis.

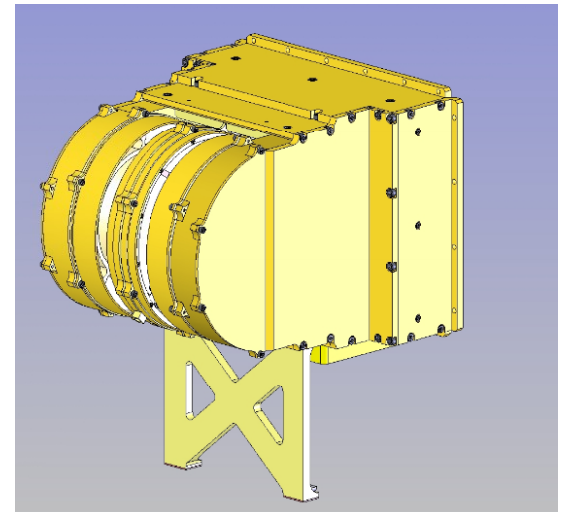

Mission Design 1: Cruise

- Separate from primary on lunar or Earth-escape trajectory.
- Point Mission Design is for Psyche ride-share (launch 08/2022).
- 15 month electric propulsion cruise to Mars rendezvous.
- Near-constant thrusting, no spinning.
- Regular DSN contacts.

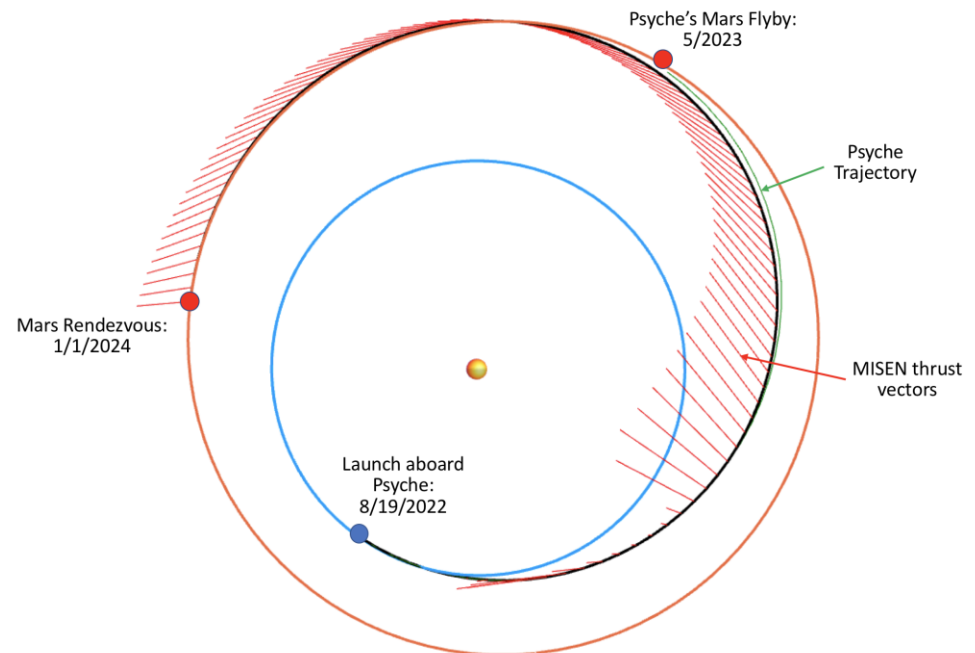

Mission Design 2: Spiral Down to Science

- Match Mars' orbit and cross its sphere of influence.
- Each spacecraft guided to its own orbital plane.
- Switch to Mars-centered Conops/Nav
- 11 months of spiraling
- End in science orbits
- Full instrument commissioning

Each spacecraft approaches Mars in its own plane, spiraling to its own target orbit.

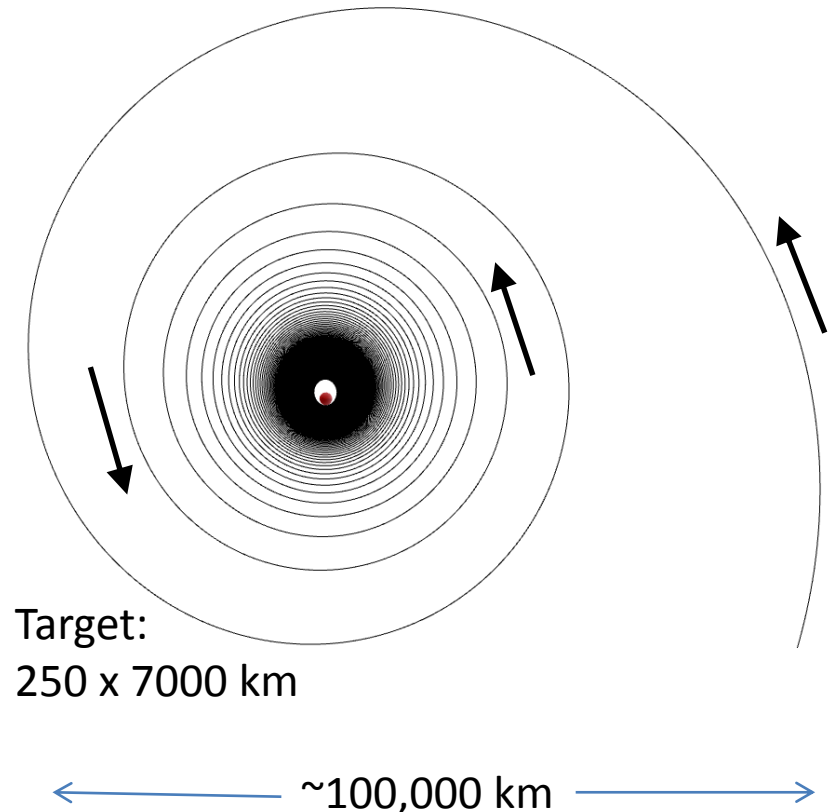

Mission Design 3: Science Orbits

- Elliptical orbits:
 - High enough to ensure outward particles are escaping.
 - Low enough to ensure inward particles are precipitating.

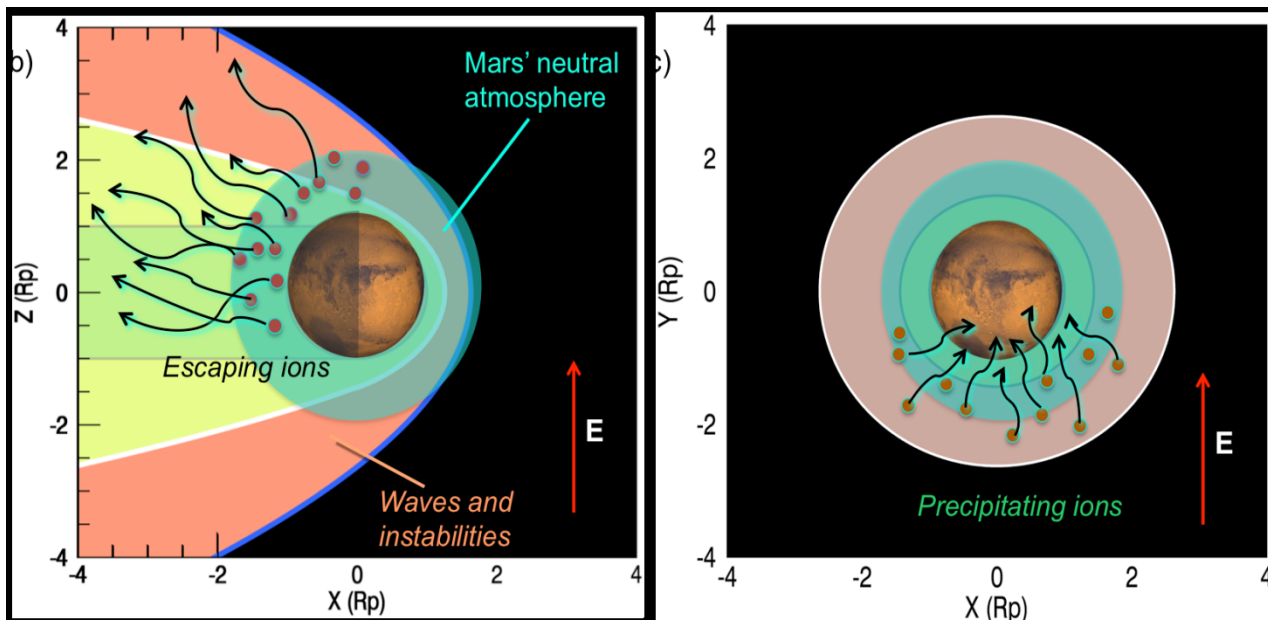

Mission Design 3: Science Orbits

- Elliptical orbits:
 - High enough to ensure outward particles are escaping.
 - Low enough to ensure inward particles are precipitating.
 - RAANs, AoPs chosen so sufficient coverage of Mars' different plasma regions is maintained as orbits precess over a 1-year primary mission.

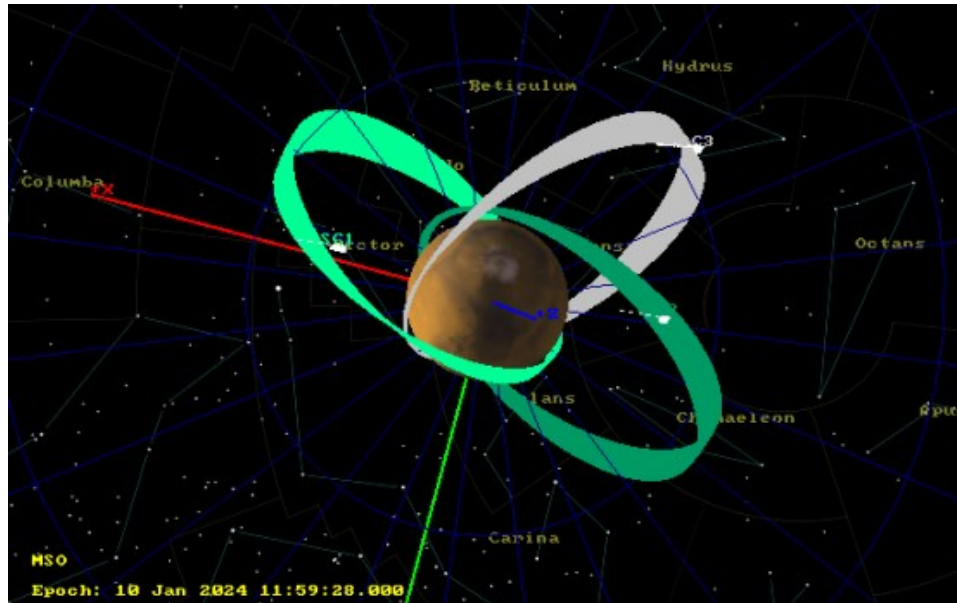

Orbits are stable, though will need ~monthly phasing maneuvers

Spacecraft Ops and architecture

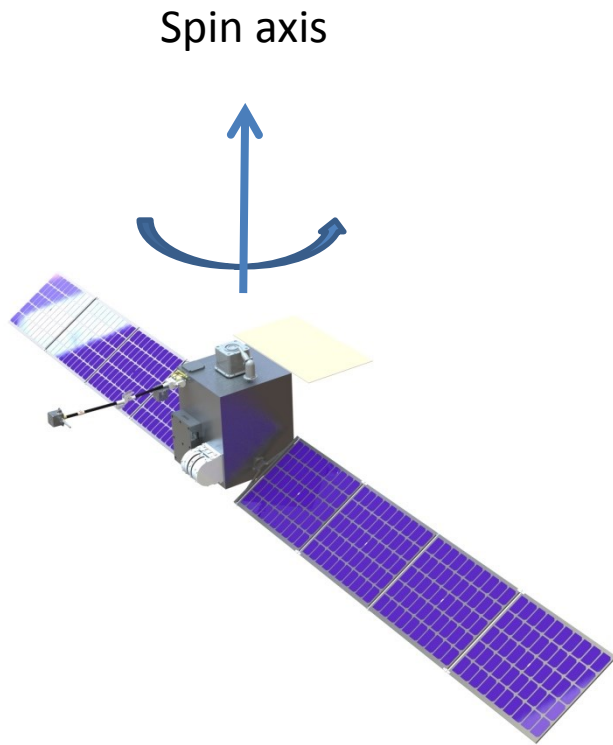

Ops:

- Three axis stabilized until science orbit.
- Spinning at 16s period after that
- Ops are simple: data collection is 'dumb' and continues indefinitely
- ~Weekly downlinks

Spacecraft:

- SC volume depends on launch point.
- Gimballed solar panels
- IRIS radio X or Ka-band
- MarCO style antenna

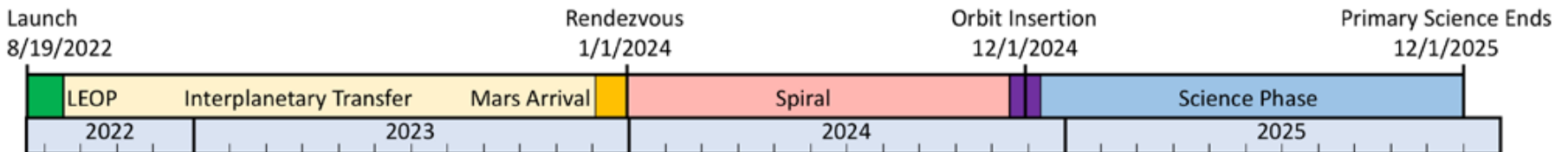

MISEN Study Team

UC Berkeley Space Sciences Lab

- PI: *Rob Lillis*
- Project Scientist: *Shannon Curry*
- Systems Engineering & Management: *Dave Curtis*
- Ion & electron analyzer: *Davin Larson, Roberto Livi, Phyllis Whittlesley*
- Science advisory: *Janet Luhmann*

UCLA Earth and Space Sciences

- Magnetometer: *Chris Russell*
- MHD modeling: *Yingjuan Ma*

Advanced Space LLC

- Mission Design & Navigation: *Jeff Parker & Nathan Parrish*

Tyvak LLC

- Spacecraft bus & subsystems: *Jordi Suig-Puari, Angelo Lopez*

University of Colorado Boulder

- Science advisory: *David Brain*

Summary

MISEN will:

- Provide simultaneous multi-point measurements of the Martian plasma environment.
- Elucidate the real-time response of the this environment to solar wind changes & disturbances (CMEs, SEPs etc)
- Reveal for the first time the global structure of ion and sputtering escape and how and why it varies.
- Build on MAVEN's legacy for a fraction of the cost.

THANK YOU to the PSDS3 Program!

BACKUP SLIDES

Feasibility Study flowchart

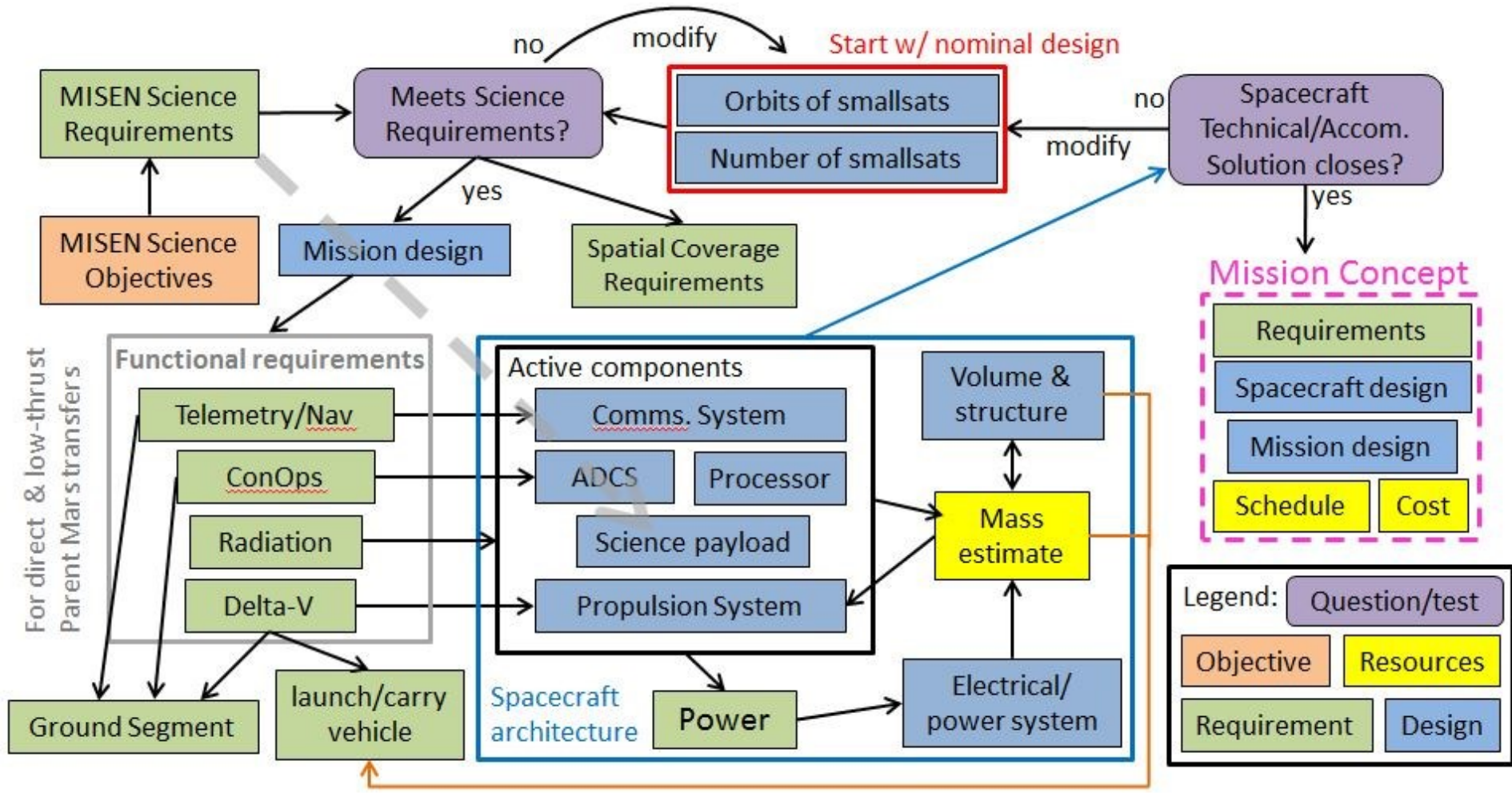

A single measurement platform leaves major questions unanswered

- a) spatial and temporal variations in escape fluxes cannot be distinguished
- b) responses of escape fluxes to changing solar wind conditions (~1 minute) can only be measured with a time-lag of an hour or (much) more
- c) global escape rate variability in response to space weather “storms” (much more common and intense in the early solar system) must be estimated (poorly) from a single orbit track.

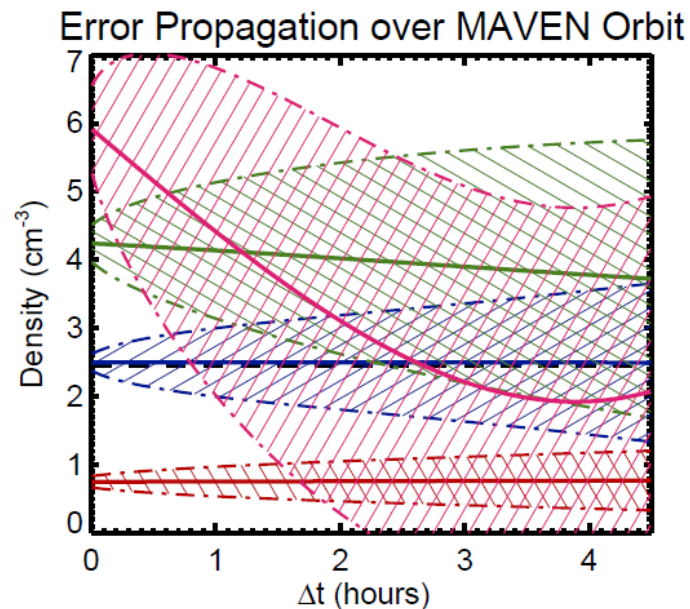

Credit: M. Marquette