

GRADES

5-8

# Bernoulli's Principle

principles of flight

Aeronautics  
Research  
Mission  
Directorate



# Bernoulli's Principle

## Lesson Overview

In this inquiry-based lesson, students will learn about energy transfer as well as motions and forces as they engage in a series of five experiments, each of which will demonstrate the Bernoulli Principle. The students will discuss the role of the Bernoulli Principle in regards to flight only after they have completed their experiments, thus giving them a context for better understanding the Bernoulli Principle.

## Objectives

Students will:

1. Explain that air is a fluid similar to water.
2. Demonstrate how the Bernoulli Principle helps create lift.
3. Use the scientific method to predict, observe and conclude.
4. Explain the relationship between the velocity of a fluid and the amount of lift created.

## Materials:

### In the Box

Drinking straws  
Ruler  
Scissors  
1 clear plastic cup  
Water  
Food coloring (optional)  
Medium-sized funnel (or the top of a 2-liter bottle)  
1 ping-pong ball

### Provided by User

Paper  
2 empty soda cans  
Several cheese balls

**GRADES**

**5-8**

**Time Requirements:** 2 hours

## Background

How is it that today's airplanes, some of which have a maximum take off weight of a million pounds or more, are able to get off the ground in the first place, let alone fly between continents? Surprisingly, even with today's technological advances, we still use the same principles of aerodynamics used by the Wright brothers in 1903. In order to gain an understanding of flight, it is important to understand the forces of flight (lift, weight, drag, and thrust), the Bernoulli Principle, and Newton's first and third laws of motion. Although the activities in this lesson primarily focus on the role the Bernoulli Principle plays in the ability of aircraft to achieve lift, the Bernoulli Principle is not the only reason for flight.

## The Forces of Flight

At any given time, there are four forces acting upon an aircraft. These forces are lift, weight, drag and thrust. Lift is the key aerodynamic force that keeps objects in the air. It is the force that opposes weight and thus, the force that helps keep an aircraft in the air. Weight is the force that works vertically by pulling all objects, including aircraft, toward the center of the Earth. In order to fly, an aircraft needs something to press it in the opposite direction of gravity, and the weight of an object controls how strong that pressure will need to be. Lift is that pressure. Drag is a mechanical force generated by the interaction and contract of a solid body, such as an airplane, with a fluid (liquid or gas). Finally there is thrust, or the force that is generated by the engines of an aircraft in order to move the aircraft forward in its path.

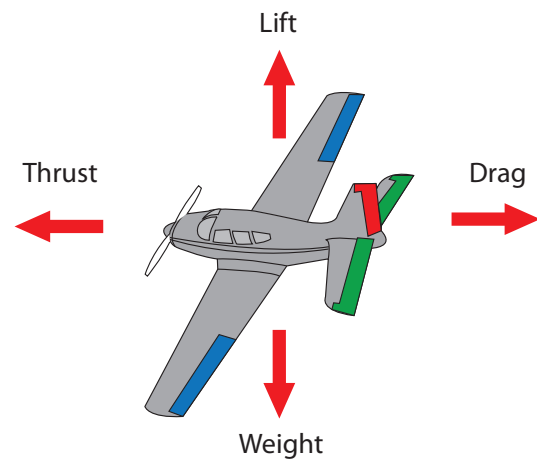

**Fig. 1** Four forces of flight

## Newton's Laws of Motion

Also, essential to an understanding of how airplanes fly, are the laws of motion first described by Sir Isaac Newton. Newton (1642 -1727) was an English physicist, mathematician, astronomer, alchemist, theologian and natural philosopher. He has long been considered one of the most influential men in human history. In 1687, Newton published the book "Philosophiae Naturalis Principia Mathematica", commonly known as the "Principia". In "Principia", Newton explained the three laws of motion. Newton's first and third laws of motion are especially helpful in explaining the phenomenon of flight. The first law states that an object at rest remains at rest while an object in motion remains in motion, unless acted upon by an external force. Newton's second law states that force is equal to the change in momentum per change in time. For constant mass, force equals mass times acceleration or  $F=m \cdot a$ . Newton's third law states that for every action, there is an equal and opposite reaction.

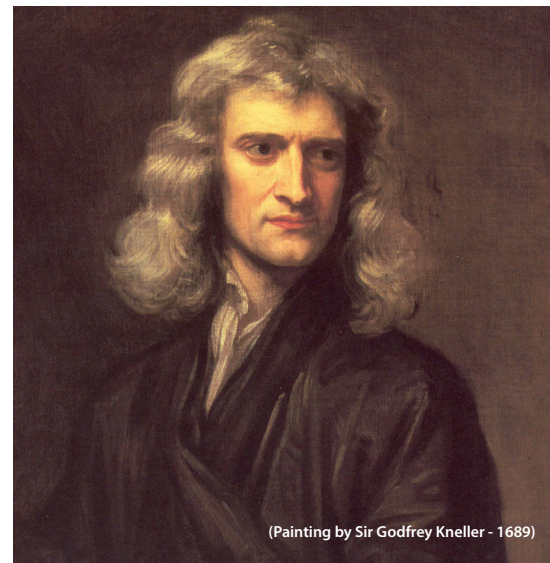

**Img. 1** Sir Isaac Newton (age 46)

## The Bernoulli Principle

So, how does Daniel Bernoulli, who is known for the Bernoulli Principle, figure into all of this? Bernoulli built his work off of that of Newton.

Bernoulli (1700 – 1782) was a Dutch-born scientist who studied in Italy and eventually settled in Switzerland. Daniel Bernoulli was born into a family of renowned mathematicians. His father, Johann Bernoulli, was one of the early developers of calculus and his uncle Jacob Bernoulli, was the first to discover the theory of probability. Although brilliant, Johann Bernoulli was both ambitious for his son Daniel and jealous of his son's success. Johann insisted that Daniel study business and later medicine, which Daniel did with distinction. It was mathematics, however, that really captured Daniel's interest and imagination. Despite Daniel's best efforts, Johann never acknowledged his son's brilliance and even tried to take credit for some of Daniel's most important ideas.



Img. 2 Daniel Bernoulli

After Daniel's studies, he moved to Venice where he worked on mathematics and practical medicine. In 1724, he published *Mathematical exercises*, and in 1725 he designed an hourglass that won him the prize of the Paris Academy, his first of ten. As a result of his growing fame as a mathematician, Daniel was invited to St. Petersburg to continue his research. Although Daniel was not happy in St. Petersburg, it was there that he wrote "*Hydrodynamica*", the work for which he is best known.

In 1738, Bernoulli published "*Hydrodynamica*", his study in fluid dynamics, or the study of how fluids behave when they're in motion. Air, like water, is a fluid; however, unlike water, which is a liquid, air is a

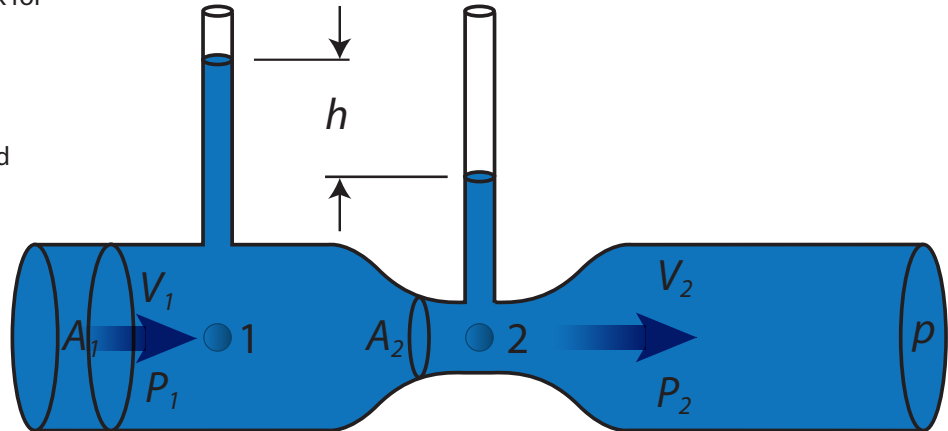

Fig. 2 Bernoulli fluid experiment

gaseous substance. Air is considered a fluid because it flows and can take on different shapes. Bernoulli asserted in "*Hydrodynamica*" that as a fluid moves faster, it produces less pressure, and conversely, slower moving fluids produce greater pressure.

By gaining an understanding of the forces at work on an airplane and what principles guide those forces, we are able to explain how lift is generated for an airplane. First, it takes a force, or thrust, to get the airplane moving. That's Newton's first law at work. This law states that an object at rest remains at rest while an object in motion remains in motion, unless acted upon by an external force.

Then because of the shape of an airplane's wing, called an airfoil, the air into which the airplane flies is split at the wing's leading edge, passing above and below the wing at different speeds so that the air will reach the same endpoint along the trailing edge of the wing at the same time. In general, the wing's upper surface is curved so that the air rushing over the top of the wing speeds up and stretches out, which decreases the air pressure above the wing. In contrast, the air flowing below the wing moves in a straighter line, thus its speed and pressure remain about the same. Since high pressure always moves toward low pressure, the air below the wing pushes upward toward the air above the wing. The wing, in the middle, is then "lifted" by the force of the air perpendicular to the wing. The faster an airplane moves, the more lift there is. When the force of lift is greater than the force of gravity, the airplane is able to fly, and because of thrust, the airplane is able to move forward in flight. According to Newton's third law of motion, the action of the wings moving through the air creates lift.

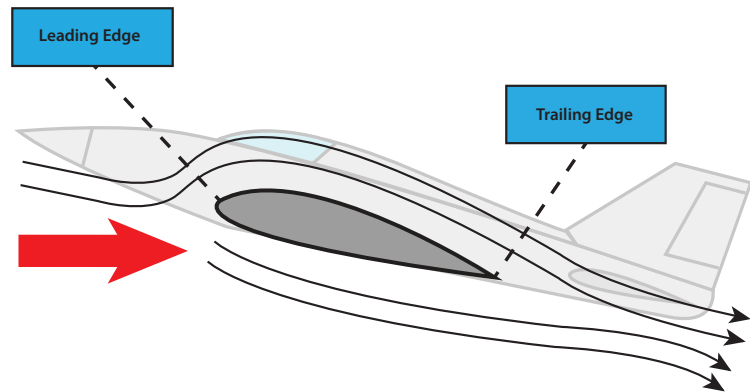

Fig. 3 Airfoil

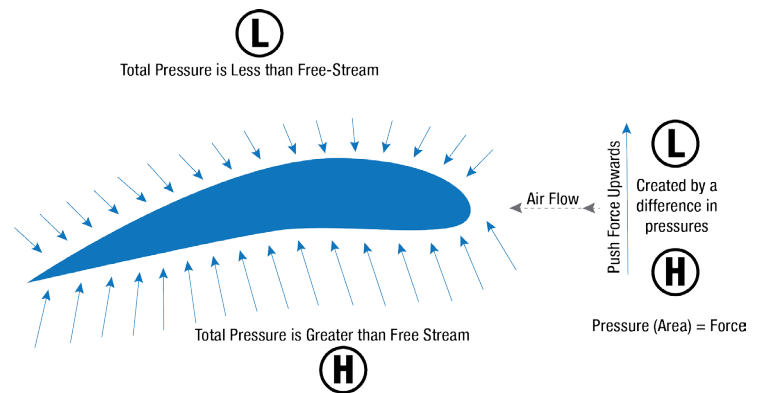

Fig. 4 Lift

## Activity 1

## Discovering the Bernoulli Principle

**GRADES****5-8****Time Requirements:** 2 hours**Materials:**In the Box

Drinking straws  
 Ruler  
 Scissors  
 1 clear plastic cup  
 Water  
 Medium-sized funnel (or  
 the top of a 2-liter bottle)  
 1 ping-pong ball

Provided by User

Paper  
 2 empty soda cans  
 Several cheese balls  
 Alcohol swabs

Worksheets

Bernoulli Experiment Log  
 (Worksheet 1)  
 Student Activity Instructions  
 (Worksheet 2)

Reference Materials

None

**Objective:**

Students will learn about motions and forces as they use the scientific method to predict, observe and conclude as they conduct a variety of experiments to discover how the velocity of air determines the amount of pressure the air is able to exert. Later, students will relate what they observed to the Bernoulli Principle.

**Activity Overview:**

Students will engage in a series of six experiments that relate to the Bernoulli Principle, first making predictions about the outcomes of their experiments. Students will record observations about each of the experiments, then participate in a discussion about Bernoulli's Principle. After the discussion, students will be able to directly relate the experiments to Bernoulli's Principle.

**Activity:****PART ONE: INTRODUCING THE EXPERIMENTS**

1. Tell the students that they will be conducting a series of experiments in which they will explore the Bernoulli Principle.
2. Tell the students that they will learn more about the specifics of the Bernoulli Principle after they have conducted their experiments and recorded their observations in their Bernoulli Experiment Log.
3. Before the students begin their experiments, introduce each experiment by showing the students the materials they will be using and providing the students with a simple overview of how each of the experiments will be conducted.
4. Distribute the Student Activity Instructions Page. Explain that the specific steps for conducting each experiment are covered in the Student Activity Instructions Page.
5. Instruct students to carefully read the directions for each experiment and predict what they think will happen.

**Key Terms:**

Air pressure  
Air foil  
Bernoulli Principle  
Conclude  
Fluid  
Fluid dynamics  
Lift  
Newton's Laws of Motion  
Observe  
Predict  
Scientific Method  
Thrust  
Velocity

6. Once the students' predictions are discussed and recorded, they may begin their experiments.
7. During the experimentation stage of the lesson, circulate throughout the classroom, facilitating discussion and guiding students through the experiments as needed. Students may want to know why the items in the experiment behave as they do, but resist the temptation to answer any "why" questions just yet. Instead, encourage the students to look for patterns in the outcomes of the experiments.

*Note: This lesson plan has two sets of instructions. This section is for the teacher, and includes instructions, expected outcomes, scientific explanations, and tips for troubleshooting. The students will receive the Student Activity Instruction Page in the Worksheets Section, which does not include these extra explanations.*

*Also, many of the experiments call for each student to have their own straw. Give each student one straw and instruct them to keep that straw as they move from experiment to experiment. Students should rotate through the experiments in order, because the last experiment to use the straw calls for the straw to be cut in half.*

## PART TWO: STUDENTS ENGAGE IN THE EXPERIMENTS

## Teacher Activity Instructions

## EXPERIMENT #1 Paper Tent

**Materials:**

Per pair of students

- One 3 ½" x 4" piece of paper

Per student

- Bernoulli Experiment Log
- One straight straw

**Instructions for the experiment:**

1. **Fold the paper in half to make a paper tent.**
2. **Place the paper tent on a flat surface such as a table or a desk.**
3. **Position the straw about 2 inches away from the paper tent so that you will be able to blow a steady stream of air across the surface of the table or desk and through the tent.**
4. **Observe what happens.**
5. **Now, blow harder and observe what happens.**
6. **Record your observations on your Bernoulli Experiment Log.**

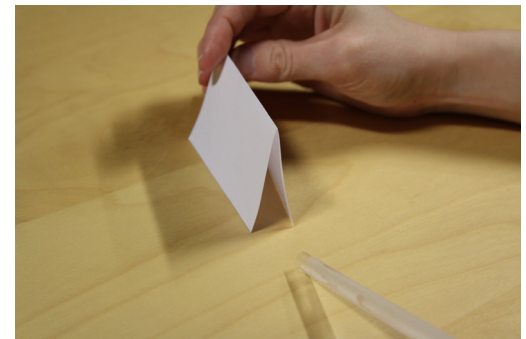
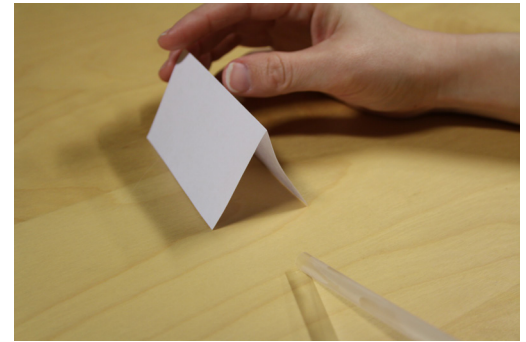
**Expected outcome and reason why:**

When the experiment is performed correctly, the sides of the card will pull towards one another. The reason for this outcome is that the faster moving air under the card creates relatively lower pressure compared to the air over the card, and as a result, the card will bend toward the table or desk because, according to the Bernoulli Principle, higher pressure air pushes toward lower pressure air.

**Troubleshooting:**

If the experiment does not work as expected, students may have the end of their straw too close to or too far away from the paper tent or they may not be blowing hard enough.



## EXPERIMENT #2 Magical Soda Cans

## Teacher Activity Instructions

### Materials:

Per pair of students

- Two empty soda cans (of the same size)
- Ruler

Per student

- Bernoulli Experiment Log
- One straight drinking straw

### Instructions for the experiment:

1. Place the two soda cans parallel to one another and  $\frac{3}{4}$  of an inch apart on a flat surface such as a table or desk.
2. Use a straw to blow between the two cans about  $1\frac{1}{4}$ -inches above the surface of the table or desk. Be sure that the open end of the straw is placed in front of the cans and not between them.
3. Observe and record what happens.



### Expected outcome and reason why:

When the experiment is performed correctly, the two cans will move together. The reason for this is that the air blowing through the straw will be faster moving than the air on any other side of the cans. Thus, according to the Bernoulli Principle, the faster moving air exerts lower pressure and the two cans are drawn toward each other.

### Troubleshooting:

If the experiment does not work as expected, students may have the cans too far apart, the straw may be too close or too far away from the cans or the students are not blowing forcefully enough through the straw.

**EXPERIMENT #5 Balancing Cheese Balls****Teacher Activity Instructions****Materials:**

Per student

- One flexible drinking straw
- One puffed cheese ball
- Bernoulli Experiment Log

**Instructions for the experiment:**

1. Bend your straw into an "L".
2. Place the long end of the straw in your mouth, with the short end pointing upwards.
3. Take a deep breath and blow steadily through the straw.
4. Try to balance the cheese ball in the stream of air coming out of the end of the straw.
5. Try to tilt your straw.
6. Observe and record what happens.

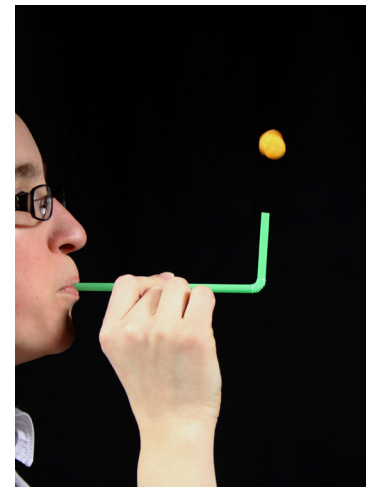
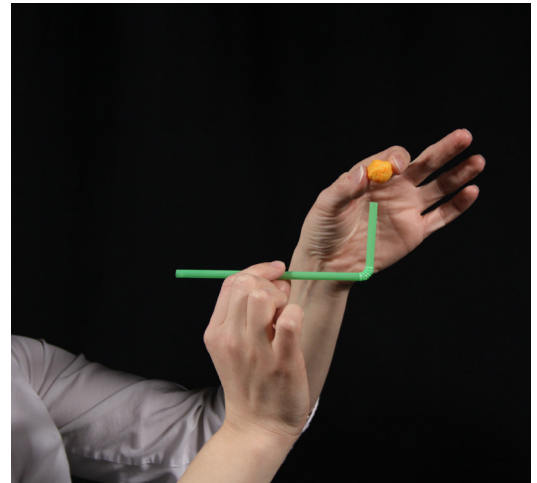
**Expected outcome and reason why:**

When the experiment is performed correctly, the cheese ball will balance itself in the steady stream of air coming from the short end of the straw. This happens because the air coming out of the straw is moving fast, so the faster moving air has less pressure than the slower moving or still air around the cheese ball. If the cheese ball starts to move away from the air stream, it experiences pressure from the still or slower moving air, which pushes the cheese ball back in place. If however, the straw is tilted, the force produced by the stream of air will no longer be sufficient to keep the cheese ball afloat because the force of gravity will then take over.

**Troubleshooting:**

If the experiment does not work as expected, students may not be blowing forcefully enough through the straw or they may be blowing with too much irregularity. A steady stream works best. Another possibility is that the short end of the straw may not be upright.

**EXPERIMENT #4 Levitate a Sphere****Teacher Activity Instructions****Materials:**

Per pair of students

- Medium-sized funnel or the top of a 2-liter pop bottle cut to look like and act as a funnel
- One ping-pong ball or one small Styrofoam ball the size of a ping-pong ball

Per student

- Bernoulli Experiment Log
- Alcohol swab (to clean the funnel when shared between students)

**Instructions for the experiment:**

1. **Place the ball in the funnel.**
2. **Tilt your head back and point the wider end of the funnel upwards toward the ceiling or sky.**  
*Note: For health reasons only one student should blow into the funnel.*
3. **Blow air forcefully through the narrow end of the funnel in an attempt to lift the ball out of the funnel.**
4. **Observe and record what happens.**
5. **Now, with ball in the funnel as before, hold the funnel in front of you and blow forcefully across the top of the wider end of the funnel.**

**Expected outcome and reason why:**

When the experiment is performed correctly, the air coming directly underneath the ping-pong ball will be moving more quickly than the air over the top of the ball. As Bernoulli's Principle states, this faster moving air results in a decrease in air pressure under the ball. This causes the ball to be pushed into, rather than out of the funnel, by the higher air pressure coming through the top of the funnel. The end result is the ball stays in the funnel.

By blowing over the top of the funnel, the speed of the air traveling over the top of the funnel is increased, which causes the air pressure in that area to decrease. Therefore, the ball rises because it is being pushed out of the funnel by the higher air pressure coming from underneath.

**Troubleshooting:**

If the experiment does not work as expected, students may be blowing too close to or too far away from the funnel, or they may be directing the air they are blowing into the funnel rather than across the top of the funnel.



**EXPERIMENT #3 Cup of Water****Teacher Activity Instructions****Materials:**

Per pair of students

- Scissors
- One clear plastic cup (a 10-ounce cup works well)
- Water

Per student

- Bernoulli Experiment Log
- One straight drinking straw

**Instructions for the experiment:**

*Note: the spray from the straws can get messy. You may wish to place a garbage bag or towel on the table to keep the area as clean as possible*

1. **Fill a clear plastic cup, nearly to the rim, with water.**
2. **Cut the drinking straw in half.**
3. **Place one half of the straw in the water so that the bottom of the straw does not touch the bottom of the cup.**
4. **The top of the straw should be sticking out above the rim of the cup.**
5. **Position the second half of the straw so that it is perpendicular to, but not touching the straw in the cup of water.** You should be able to blow a stream of air over the hole of the straw sticking out of the water.
6. **Once the straw is in position, blow very hard through the straw.**
7. **Observe and record what happens.**

**Expected outcome and reason why:**

When the experiment is performed correctly, the water will rise through the straw in the cup, spraying away from the stream of air being blown across the straw.

The reason for this is that as the student blows through the straw, the faster moving air over the top of the straw creates an area of low pressure while the pressure on the surface of the water remains unchanged. Therefore, the water is drawn up the straw because of the area of low pressure.

**Troubleshooting:**

If the experiment does not work as expected, students may not be blowing through the straw with enough force or they may be blowing too close to or too far away from the top of the straw that is positioned in the water.



**PART THREE: RELATING THE EXPERIMENTS TO THE BERNOULLI PRINCIPLE**

1. **After the students have completed their experiments, ask them to explain what they have observed.** Teachers may wish to record and display students' observations on a chart similar to the student's Bernoulli Experiment Log.
2. **Ask the students if what they observed was what they predicted. If their predicted and actual outcomes differed, ask the students to hypothesize as to why.**
3. **Ask the students if they saw any patterns in the outcomes of the experiments. Record students' ideas.**
4. **Before presenting the Bernoulli Principle, ask the students how they would classify air.** In other words, ask them what kind of substance air is. Students will likely describe air as a gas. They may also say that air is a combination of gases, including water vapor, and other particles such as dust. If the students do not offer a description of air as a fluid, ask them if they would consider air a fluid.
5. **Tell the students that there is a test for determining if air is a fluid or not.** Tell them that you are going to give them this test. Begin by asking: Does air resist molding, shaping or being deformed? Can you move, bend, or twist air with relative ease? Try it. (Students will say that it is relatively easy to deform air) Next ask: What shape is air? Can the shape of air be changed? How? (Students will say that air can change shape depending on the container it's in.) Tell the students that because they answered yes to these questions, air has passed the test. Air is indeed a fluid because air, like other fluids, displays such properties as not resisting deformation, and it displays the ability to flow, which is also described as the ability to take on any shape. Make sure students understand that while all liquids are fluids, not all fluids are liquids.
6. **Introduce the Bernoulli Principle by saying:**

The Bernoulli's Principle is a physical phenomenon that was named after the Swiss scientist, Daniel Bernoulli, who lived during the eighteenth century. Bernoulli studied the relationship between the speed of a fluid and the pressure that fluid is able to exert. The principle states that "the pressure of a fluid [liquid or gas] decreases as the speed of the fluid increases." Within the same fluid, high-speed flow is associated with low pressure, and low-speed flow is associated with high pressure.

*Note: At this point teachers may choose to show their students a picture of Daniel Bernoulli and his glass tube experiment or give more background about his life and studies.*
7. **Now relate the Bernoulli Principle to the lift achieved by an aircraft.** Explain that lift is the force that helps an aircraft fly. Tell the students that lift occurs, in part, when the air traveling over the top of an airplane wing moves faster than the air traveling under the wing. Thus, the faster moving air creates an area of low pressure, while the slower moving air creates an area of high pressure.

8. **Show students a diagram of an airfoil (a cross-section of an airplane wing).** Explain, using arrows, how the faster moving air spreads out and speeds up over the upper surface of a wing to create low pressure, while the air traveling under the wing moves at a slower rate, thus creating high pressure. High pressure moves toward low pressure, thus generating lift.
9. **Direct the students' attention back to their experiments.** Ask the students how they saw the Bernoulli Principle at work. Prompt the students to recall what happened when they increased the speed of the air in their experiments. Students will recall that every time they changed the speed of the air in their experiment (by increasing it relative to the surrounding air), something moved in the direction of the faster moving air (the paper tent, the cans, the water, and the ping-pong ball). In the case of the "Balancing Cheese Ball", the slower moving air around the cheese ball kept the cheese ball positioned above the faster moving air being blown underneath it.
10. **Recreate a few of the experiments (or all if you prefer) as demonstrations.** Give the students time to explain what was actually happening in each, according to the Bernoulli Principle.
11. **Allow students to share their conclusions and use their own words to describe how the Bernoulli Principle relates to the experiments they conducted.**

# NATIONAL SCIENCE STANDARDS 5-8

## SCIENCE AS INQUIRY

- Abilities necessary to do scientific inquiry
- Understandings about scientific inquiry

## PHYSICAL SCIENCE

- Motions and forces

## SCIENCE AND TECHNOLOGY

- Abilities of technological design
- Understanding about science and technology







Reference Materials

# Glossary

**Air pressure:**

The amount of pressure air is able to exert on substances or objects; air pressure can be high or low, depending on the speed at which it travels

**Airfoil:**

A surface or section of a surface that is designed to help lift an aircraft with the use of air current

**Bernoulli Principle:**

An increase in the velocity of any fluid is always accompanied by a decrease in pressure

**Conclude:**

To determine by reasoning

**Fluid:**

A substance that can easily change its shape and is capable of flowing

**Fluid dynamics:**

The subject of fluids in motion

**Lift:**

The upward force created by the wings moving through the air that helps to sustain the airplane in flight

**Newton's Laws of Motion:**

An explanation for the principles of motion and gravity

**Law One:** Every object persists in its state of rest or uniform motion in a straight line unless it is compelled to change that state by forces impressed on it.

**Law Two:** Force is equal to change in momentum per change in time. For a constant mass force equals mass times acceleration.  $F = m \cdot a$

**Law Three:** For every action there is an equal and opposite re-action.

**Observe:**

To watch, or view, for a scientific purpose

**Predict:**

To indicate something in advance based on prior knowledge

**Scientific Method:**

A method of research in which a problem is identified, relevant data are gathered, a hypothesis is formulated from these data, and the hypothesis is empirically tested

**Thrust:**

A force that pushes the air backward with the object of causing movement of the airplane in the forward direction

**Velocity:**

The rate of speed with which something happens

**Fig. 1** Four forces of flight

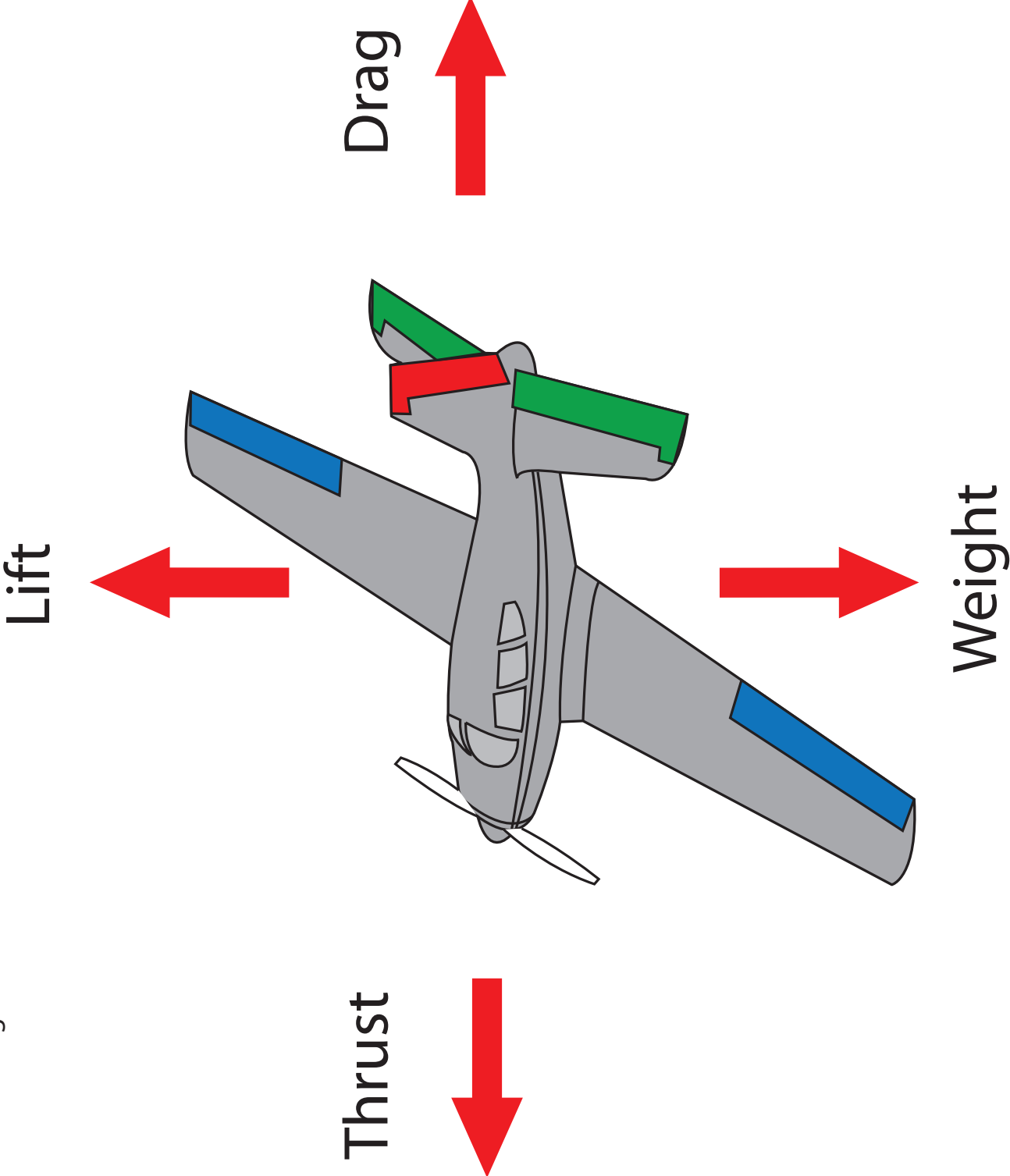

**Fig. 2** Bernoulli fluid experiment

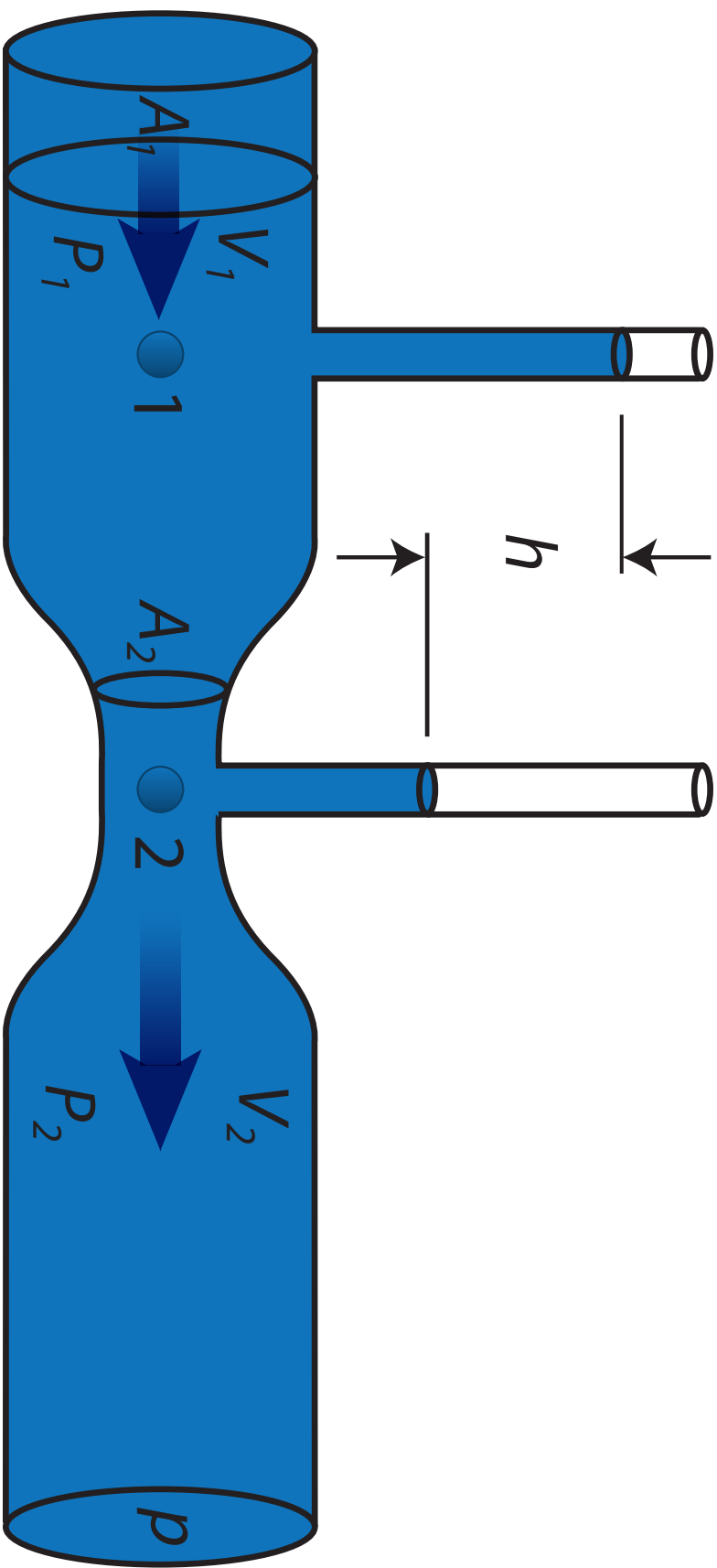

**Fig. 3** Airfoil

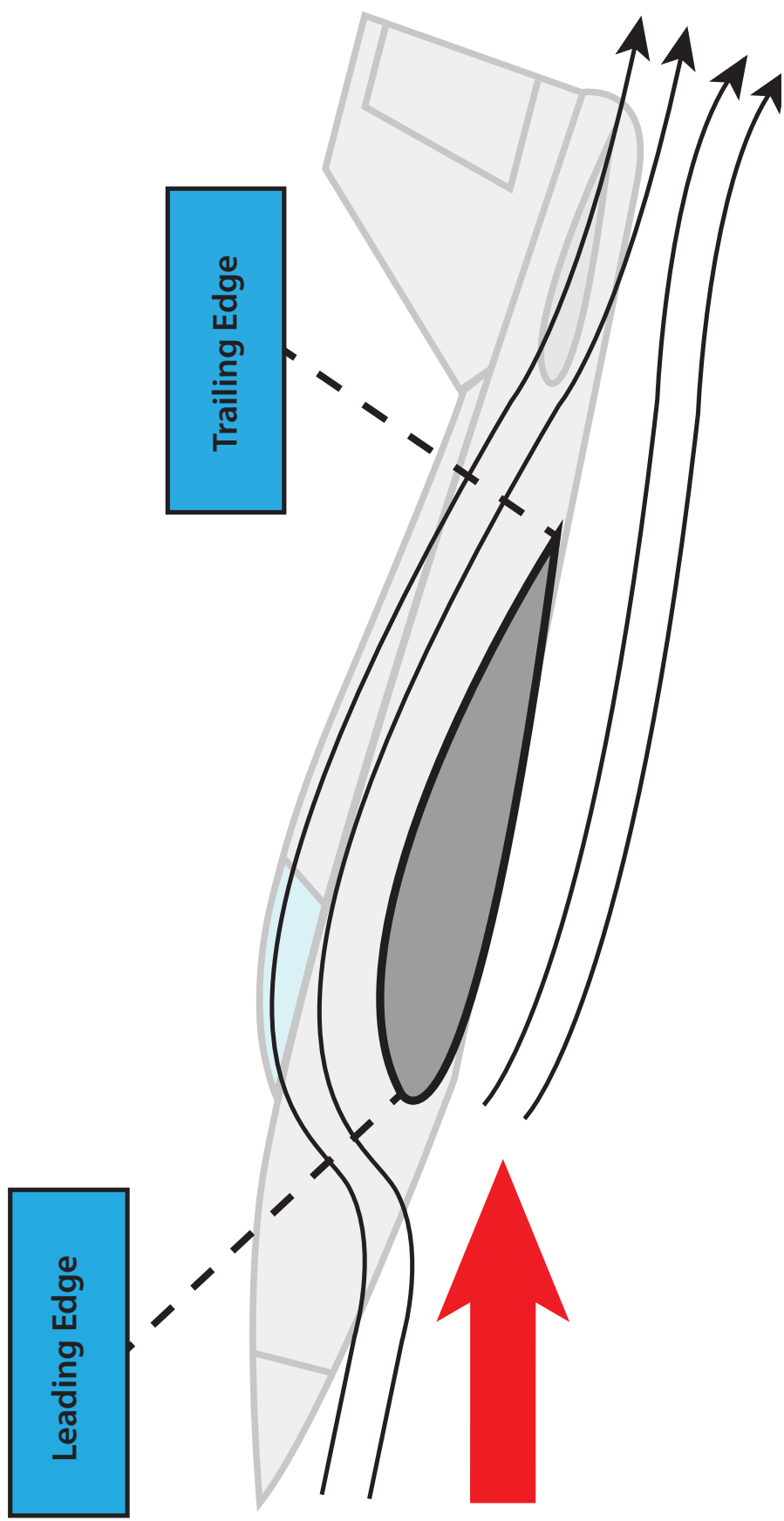
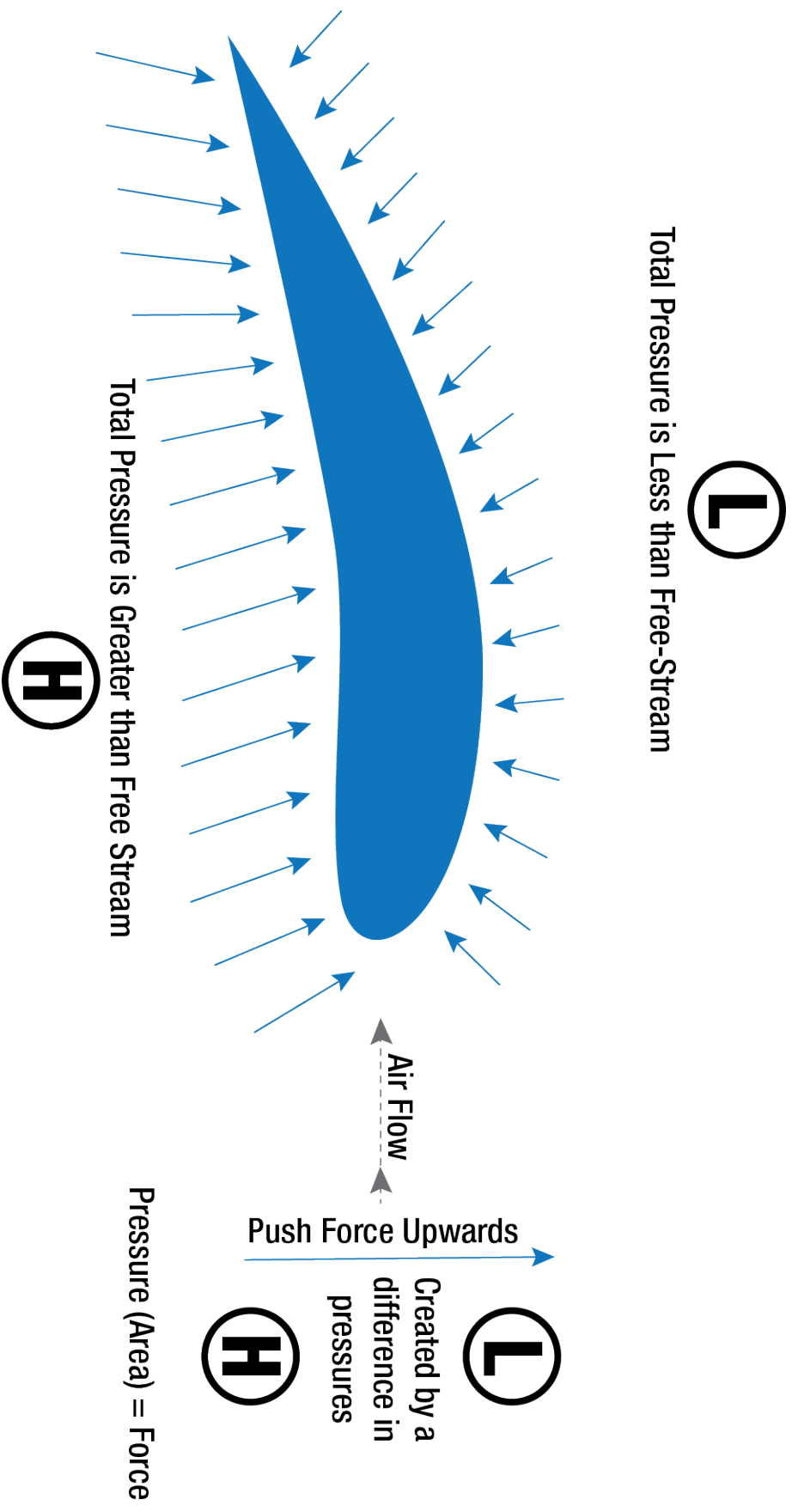

Fig. 4 Lift





Worksheets

## Worksheet 1

## Bernoulli Experiment Log

After your teacher introduces the experiments and you have read the Student Activity Instructions Page, predict what you think will happen in each experiment before you begin. Then after you complete each experiment, record what you observed during the experiment. Finally, after you learn more about the Bernoulli Principle, give reasons for the outcome of each experiment including how the outcome relates to the Bernoulli Principle. Write all of your responses in the boxes below.

Experiment	What do you think will happen? <i>Predict</i>	What happened? <i>Observe</i>	Why did it happen? <i>Conclude</i>
Paper Tent: Normal Air-flow			
Paper Tent: Increased Airflow			
Magical Soda Cans			
Cup of Water			
Levitate a Sphere			
Balancing Cheese Balls			

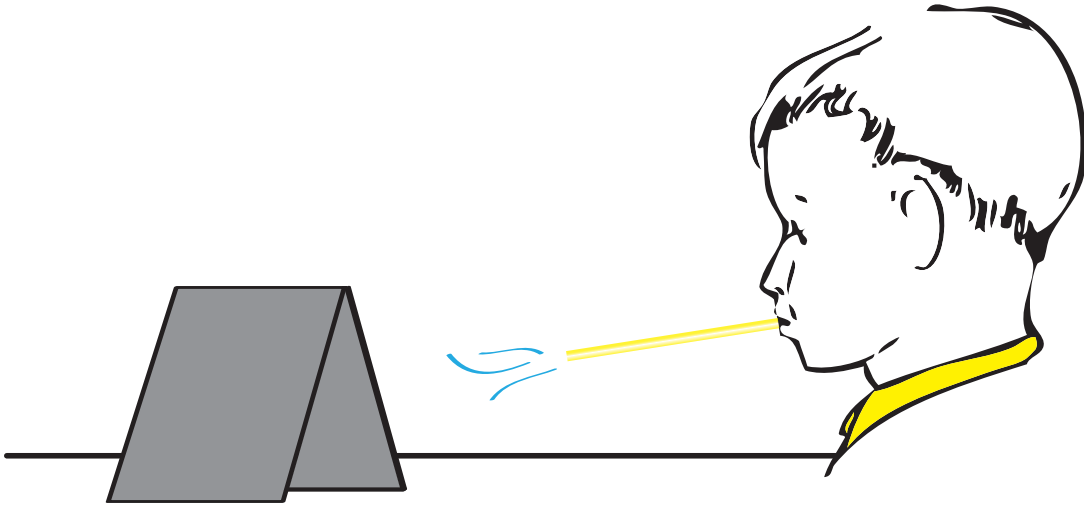

**EXPERIMENT #1 Paper Tent****Materials:**

Per pair of students

- One 3 ½" X 4" piece of paper

Per student

- Bernoulli Experiment Log
- One straight straw

**Instructions for the Experiment:**

1. Fold the paper in half to make a paper tent.
2. Place the paper tent on a flat surface such as a table or a desk.
3. Position the straw about 2 inches away from the paper tent so that you will be able to blow a steady stream of air across the surface of the table or desk and under the tent.
4. Observe what happens.
5. Now, blow harder and observe.
6. Record your observations on your Bernoulli Experiment Log.

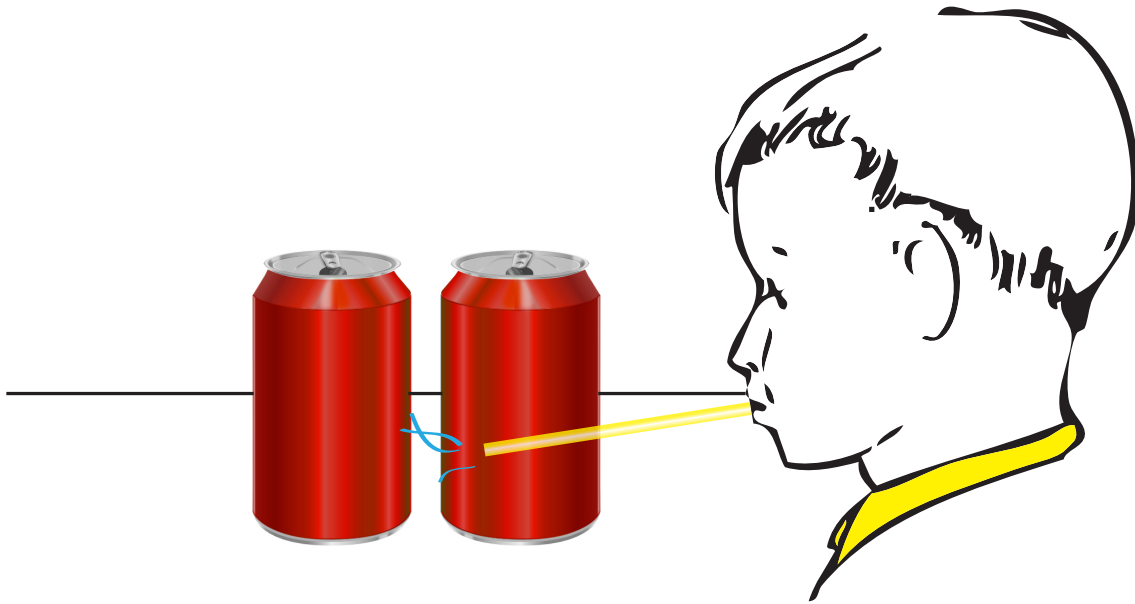
**EXPERIMENT #2 Magical Soda Cans****Materials:**

One set per pair of students

- Two empty soda cans (of the same size)
- Ruler

Per student

- Bernoulli Experiment Log
- One straight drinking straw

**Instructions for the Experiment:**

1. Place the two soda cans parallel to one another and  $\frac{3}{4}$  of an inch apart on a flat surface such as a table or desk.
2. Use a straw to blow between the two cans about  $1\frac{1}{4}$ -inches above the surface of the table or desk. Be sure that the open end of the straw is placed in front of the cans and not between them.
3. Observe and record what happens.

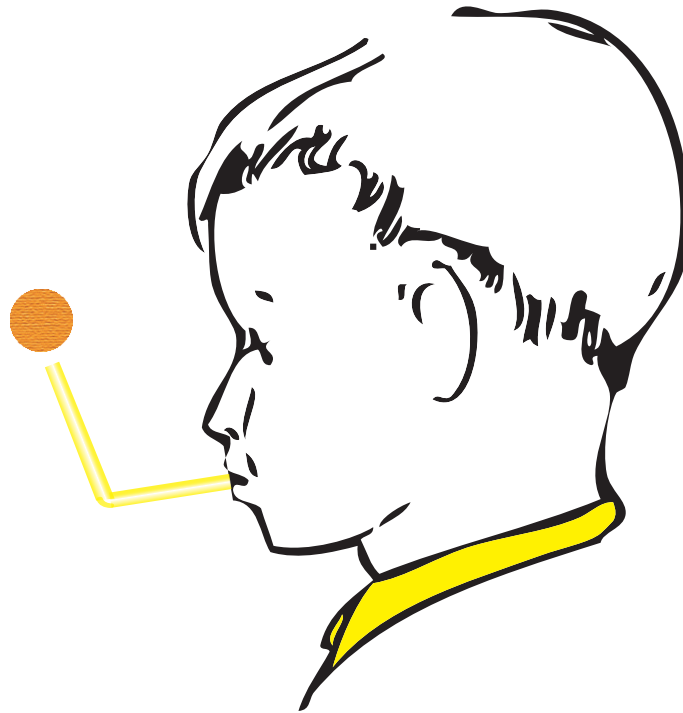
**EXPERIMENT #3 Balancing Cheese Balls****Materials:**

Per student

- One flexible drinking straw
- One puffed cheese ball
- Bernoulli Experiment Log

**Instructions for the Experiment:**

1. Bend your straw into an "L".
2. Place the long end of the straw in your mouth, with the short end pointing upwards.
3. Take a deep breath and blow steadily through the straw.
4. Try to balance the cheese ball in the stream of air coming out of the end of the straw.
5. Try to tilt your straw.
6. Observe and record what happens.

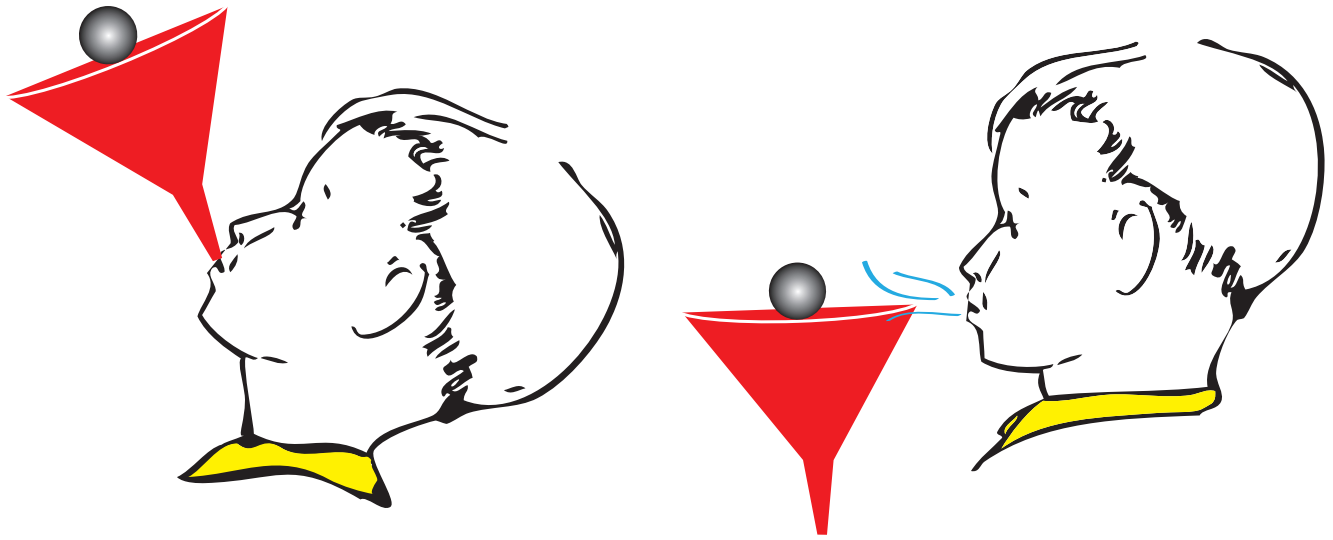
**EXPERIMENT #4 Levitate a Sphere****Materials:**

Per pair of students

- Medium-sized funnel or the top of a 2-liter pop bottle cut to look like and act as a funnel
- One ping-pong ball or one small Styrofoam ball the size of a ping-pong ball

Per student

- Bernoulli Experiment Log
- Alcohol swab

**Instructions for the Experiment:**

1. Place the ball in the funnel.
2. Tilt your head back and point the wider end of the funnel upwards toward the ceiling or sky.

*Note: For health reasons only one student should blow into the funnel.*

3. Blow air forcefully through the narrow end of the funnel in an attempt to lift the ball out of the funnel.
4. Observe and record what happens.
5. Now, with ball in the funnel as before, hold the funnel in front of you and blow forcefully across the top of the wider end of the funnel.

**EXPERIMENT #5 Cup of Water****Materials:**

Per pair of students

- One clear plastic cup
- Water

Per student

- Bernoulli Experiment Log
- One straight drinking straw

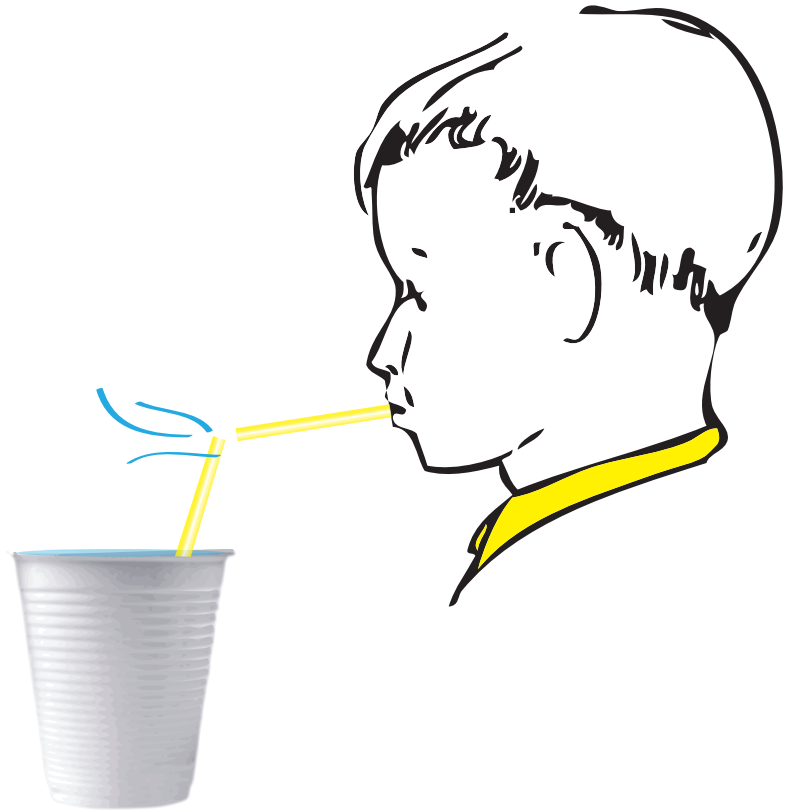
**Instructions for the Experiment:**

1. Fill a clear plastic cup, nearly to the rim, with water.
2. Cut the drinking straw in half.
3. Place one half of the straw in the water so that the bottom of the straw does not touch the bottom of the cup.
4. The top of the straw should be sticking out above the rim of the cup.
5. Position the second half of the straw so that it is perpendicular to, but not touching the straw in the cup of water. You should be able to blow a stream of air over the hole of the straw sticking out of the water.
6. Once the straw is in position, blow very hard through the straw.
7. Observe and record what happens.





Images

**Img. 1** Sir Isaac Newton (age 46)

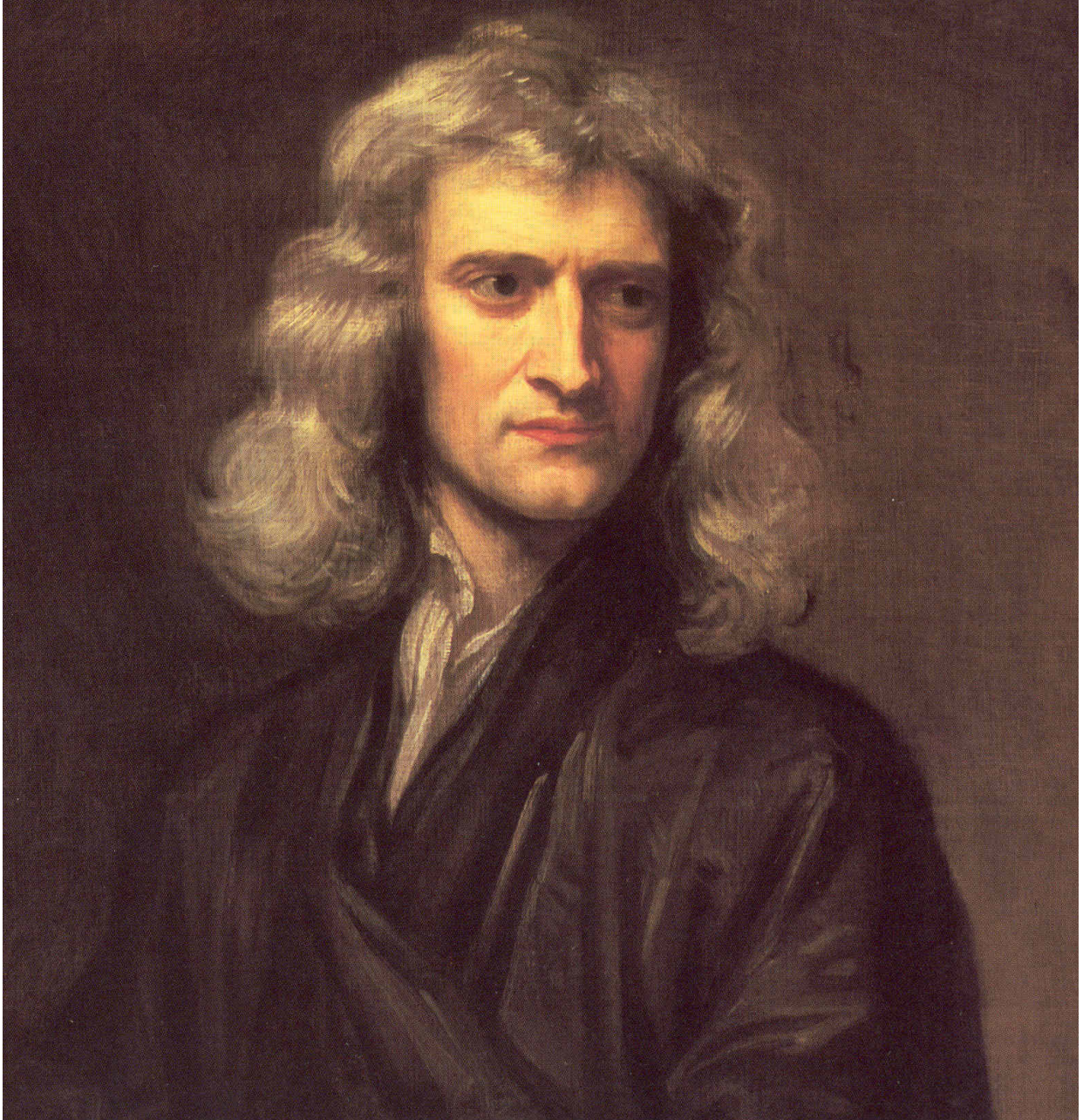

(Painting by Sir Godfrey Kneller - 1689)



**Img. 2** Daniel Bernoulli



(Public Domain)

Aeronautics  
Research  
Mission  
Directorate

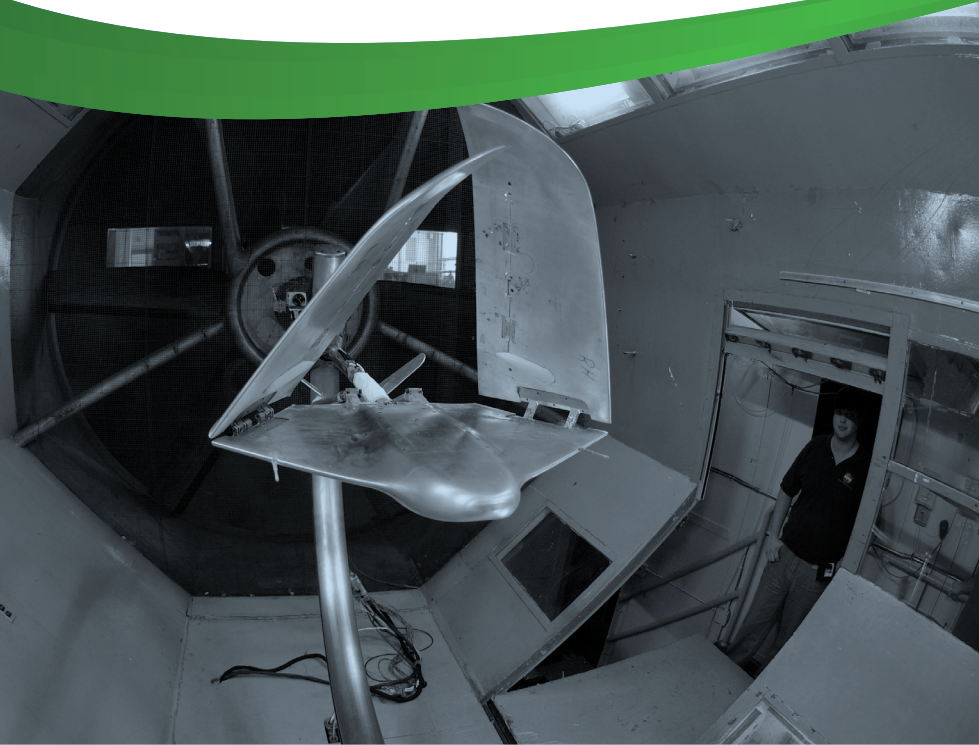

principles of flight