

STS-109



## Rejuvenating the World's Greatest Observatory

[WWW.SHUTTLEPRESSKIT.COM](http://WWW.SHUTTLEPRESSKIT.COM)



Updated February 14, 2001

## Table of Contents

<b>Mission Overview</b> .....	1
<b>Mission Objectives</b> .....	9
<b>Introduction</b> .....	10
<b>Who Was Edwin P. Hubble?</b> .....	14
<b>Hubble Space Telescope: A Great Observatory Continues Its Quest</b> .....	15
<b>Hubble Space Telescope Servicing Mission 3B: Cost to Taxpayers</b> .....	21
<b>Future of Hubble: Servicing Mission 4 and Beyond</b> .....	23
<b>Crewmembers</b> .....	24
<b>Flight Day Summary Timeline</b> .....	28
<b>Payloads</b>	
Advanced Camera for Surveys .....	29
Power Control Unit .....	32
NICMOS Cryocooler .....	34
Solar Arrays .....	36
Reaction Wheel Assembly .....	39
<b>Rendezvous</b>	
Hubble Space Telescope Rendezvous, Capture, Berthing and Deploy .....	40
<b>Spacewalk</b>	
STS-109 Extravehicular Activity .....	43
EVA Timeline Overview .....	53

# STS-109

---

## **Experiments: DTOs and DSOs**

DTO 700-14 .....	54
DTO 805 .....	54
DSO 490 .....	55
DSO 493 .....	55
DSO 496 .....	55
DSO 498 .....	56
DSO 500 .....	56
DSO 503S .....	56
DSO 634 .....	57
DSO 635 .....	57
DSO 802 .....	57

## **Appendix**

### **Shuttle Reference Data**

Shuttle Abort History .....	58
Shuttle Abort Modes .....	60
Shuttle Rendezvous Maneuvers .....	64
Shuttle Solid Rocket Boosters .....	65
Shuttle Super-lightweight Tank .....	72
<b>Acronyms and Abbreviations</b> .....	<b>73</b>
<b>Media Assistance</b> .....	<b>75</b>
<b>Media Contacts</b> .....	<b>77</b>

# STS-109

---

## **Mission Overview**

The STS-109 mission of Columbia to service the Hubble Space Telescope is scheduled for launch no earlier than 6:48 a.m. EST on Thursday, Feb. 28, 2002, from Launch Pad 39-A at the Kennedy Space Center, FL. The mission is commanded by Scott Altman, a commander in the U.S. Navy, with Duane Carey, a lieutenant colonel in the U.S. Air Force, serving as Pilot. Dr. John Grunsfeld will be Mission Specialist 1 and Payload Commander and Nancy Currie, a lieutenant colonel in the U.S. Army, is the Flight Engineer and Mission Specialist 2. Dr. Rick Linnehan is Mission Specialist 3, Dr. Jim Newman will serve as Mission Specialist 4 and Dr. Mike Massimino will be Mission Specialist 5.

Altman and Linnehan are making their third flights into space. Grunsfeld, Currie and Newman are embarking on their fourth flights, while Carey and Massimino are first-time fliers. Currie and Newman flew together on the STS-88 mission in 1998, the first International Space Station assembly flight, while Grunsfeld's last flight in 1999 occurred on the last Hubble servicing mission, STS-103.

Grunsfeld and Newman are spacewalking veterans, while Linnehan and Massimino will be conducting spacewalks for the first time.



*Hubble is serviced by Astronauts Story Musgrave and Jeff Hoffman on STS-61.*

## STS-109

---

On STS-109, the Hubble Space Telescope will be serviced for the fourth time since it was launched, as Grunsfeld and Linnehan team up to conduct three spacewalks and Newman and Massimino are paired for two spacewalks to install new, more durable solar arrays, a large gyroscopic assembly to help point the telescope properly, a new telescope power control unit and a cooling system to restore the use of a key infrared camera and spectrometer instrument which has been dormant since 1999.



***The Advanced Camera for Surveys has the potential to be 10 times more powerful in its view of the Universe than the current wide field imager, WFPC 2.***

In addition, almost 12 years after Hubble was launched, the telescope's view of the Universe will be dramatically improved with the addition of the newest scientific instrument - the Advanced Camera for Surveys (ACS). With up to four times the speed of previous instruments, this device will be able to survey a field of the cosmos twice as large as before with ten times the resolution. The new instrument's potential dwarfs the capability of the existing and complementary Wide Field Planetary Camera, which provided the world's astronomers with breathtaking views of the Eagle Nebula and the Hubble Deep Field in recent years. The ACS will replace the Faint Object Camera, the last of Hubble's original instruments and the last to require the corrective optics that were installed in Hubble during the first servicing mission in 1993. All of the current generation instruments have their own internal corrective mirrors.

## STS-109

---

The new solar arrays, which are the third set of power-generating wings for Hubble in its history, will generate 20 percent more power at two-thirds the size of the current arrays, with a new rigidity and durability that will provide the telescope with enough power for the rest of its operational lifetime. Rather than rolling up, the arrays each fold in two sections, providing greater reliability than its predecessors.



***Reaction Wheel Assembly (RWA)***

One of four Reaction Wheel Assemblies will be replaced during the flight. This mechanism helps to maneuver the telescope into the proper orientation for scientific observations. Although the assembly has not failed, it is exhibiting erratic behavior. Only three of the four assemblies are required for science, but a new assembly will be installed to insure Hubble's capability for new discoveries in the years to come.

The new Power Control Unit is the heart of electrical production for Hubble's systems. This unit will collect energy from the new solar arrays and distribute that power to all key Hubble components. The original unit has been operating since Hubble's launch in 1990. With Hubble's mission of discovery now extended to 2010, the new power unit will enable Hubble to remain healthier and more productive. Its replacement will be the most complex task of the mission, requiring the delicate disconnection and reconnection of 36 small and closely spaced electrical connectors by the spacewalking astronauts. For the first time in history, all of Hubble's systems will be completely shut down to accommodate the spacewalking upgrade effort, which should take seven hours or more to complete.

The spacewalks and specific tasks to upgrade Hubble's instruments are regarded as more intricate and challenging than astronauts have encountered in previous servicing missions.



***Nancy Currie uses the virtual reality lab at the Johnson Space Center to train for some of her duties aboard Columbia.***

One of NASA's Great Observatories, Hubble will be retrieved by Currie using the shuttle's robot arm on the third day of the flight, setting the stage for five consecutive days of spacewalks. HST will be berthed on a special work platform at the rear of Columbia's cargo bay, which can swivel and tilt to present various work sites to the spacewalking astronauts. Within hours after it is retrieved and berthed, HST's solar arrays will be rolled up and retracted, clearing the way for their replacement on the first two spacewalks of the flight.

The starboard solar array and its accompanying electronics systems will be replaced on the first spacewalk on the fourth day of the mission by Grunsfeld and Linnehan, with the port array and its electronics to be replaced the following day by Newman and Massimino. During that second spacewalk, the new Reaction Wheel Assembly will also be installed in Hubble.

After each of the arrays is changed out, ground controllers at the Goddard Space Flight Center responsible for the telescope's health and operation will conduct a thorough checkout to ensure that the new "wings" are functioning properly.

During the third and longest spacewalk on the sixth day of the flight, the most intricate task of the mission will be attempted. HST controllers will send commands to shut down all of Hubble's systems for the first time to enable Grunsfeld and Linnehan to replace the telescope's Power Control Unit. The component was not originally intended to be replaced. But managers elected to change out the 160-pound instrument to accommodate HST



## STS-109

---

operations for the duration of the lifetime of the telescope and to help regulate and properly distribute the additional power generated by Hubble's new solar arrays. Grunsfeld and Linnehan will be working primarily by feel as they disconnect and reconnect the control unit's various electrical connectors. Columbia will be maneuvered into the proper orientation for the duration of the planned seven-hour spacewalk to maintain the correct temperature for the telescope while its thermal systems are shut down.

The fourth spacewalk by Newman and Massimino on the seventh day of the mission is designed to install the new ACS and its associated electronics components. The final spacewalk by Grunsfeld and Linnehan on the flight's eighth day will install a high-tech cooling device to regain the use of the Near Infrared Camera and Multi-Object Spectrometer, which has been inoperable since early 1999 when nitrogen ice was depleted because of a tiny heat leak from a thermos-like instrument designed to keep its infrared detectors at a super-cold temperature.



***HST is first deployed on shuttle mission STS-31.***

Currie will operate Columbia's robot arm once again to redeploy Hubble on the ninth day of the mission to continue its unprecedented studies of the cosmos. Science observations should resume around three weeks after Hubble is deployed, with the ACS expected to offer its first glimpse of the Universe around 9-10 weeks after the mission. Hubble's next shuttle service call is planned for no earlier than the summer of 2004.

# STS-109

---

The flight will be the 27<sup>th</sup> for Columbia and its first mission since undergoing major modifications after its last flight in 1999. STS-109 will be the 108<sup>th</sup> flight in the history of the shuttle program. Landing is scheduled at about 3:38 a.m. EST on March 11, 2002, at the Kennedy Space Center.

---

## Crew

<b>Commander:</b>	Scott D. Altman
<b>Pilot:</b>	Duane G. Carey
<b>Mission Specialist 1:</b>	John M. Grunsfeld
<b>Mission Specialist 2:</b>	Nancy J. Currie
<b>Mission Specialist 3:</b>	Richard M. Linnehan
<b>Mission Specialist 4:</b>	James H. Newman
<b>Mission Specialist 5:</b>	Michael J. Massimino

---

## Launch

<b>Orbiter:</b>	Columbia (OV-102)
<b>Launch Site:</b>	Kennedy Space Center Launch Pad 39A
<b>Launch Window:</b>	TBA
<b>Altitude:</b>	308 Nautical Miles
<b>Inclination:</b>	28.5 Degrees
<b>Duration:</b>	10 Days 20 Hrs. 50 Min.

---

## Vehicle Data

<b>Shuttle Liftoff Weight:</b>	4515376 lbs.
<b>Orbiter/Payload Liftoff Weight:</b>	257913 lbs.
<b>Orbiter/Payload Landing Weight:</b>	221703 lbs.

**Software Version:** OI-28

**Space Shuttle Main Engines:** (1 MB pdf)

**SSME 1:** 2056

**SSME 2:** 2053

**SSME 3:** 2047

**External Tank:** ET-112A ( Super Light Weight Tank)

# STS-109

---

**SRB Set:** BI111PF

---

## Shuttle Aborts

## Abort Landing Sites

**RTLS:** Kennedy Space Center Shuttle Landing Facility

**TAL:** Ben Guerir

**AOA:** Edwards Air Force Base, California

---

## Landing

**Landing Date:** 03/11/02

**Landing Time:** 3:38 AM (eastern time)

**Primary Landing Site:** Kennedy Space Center Shuttle Landing Facility

---



## **STS-109 Mission Objectives**

The Hubble Space Telescope Servicing Mission 3B mission objectives are to complete the following tasks:

- Reaction Wheel Assembly 1 replacement.
- Replacement of HST's current solar arrays with new, more durable and more capable arrays.
- The replacement of the HST's Power Control Unit.
- The installation of the new scientific instrument, the Advanced Camera for Surveys.

## Introduction

The Hubble Space Telescope (HST)—named for the distinguished American astronomer Edwin P. Hubble—is an Earth-orbiting observatory which was designed to revolutionize astronomy and astrophysics by providing answers to many of the outstanding questions which had vexed scientists for decades. In this it has succeeded to a degree that has not only thrilled astronomers and energized the international astronomical community, but has also served as a source of pride and inspiration to the nation. In addition, HST has paved the way for unexpected new findings about our Universe, and these in turn have prompted new questions. Such is the cycle of scientific inquiry.

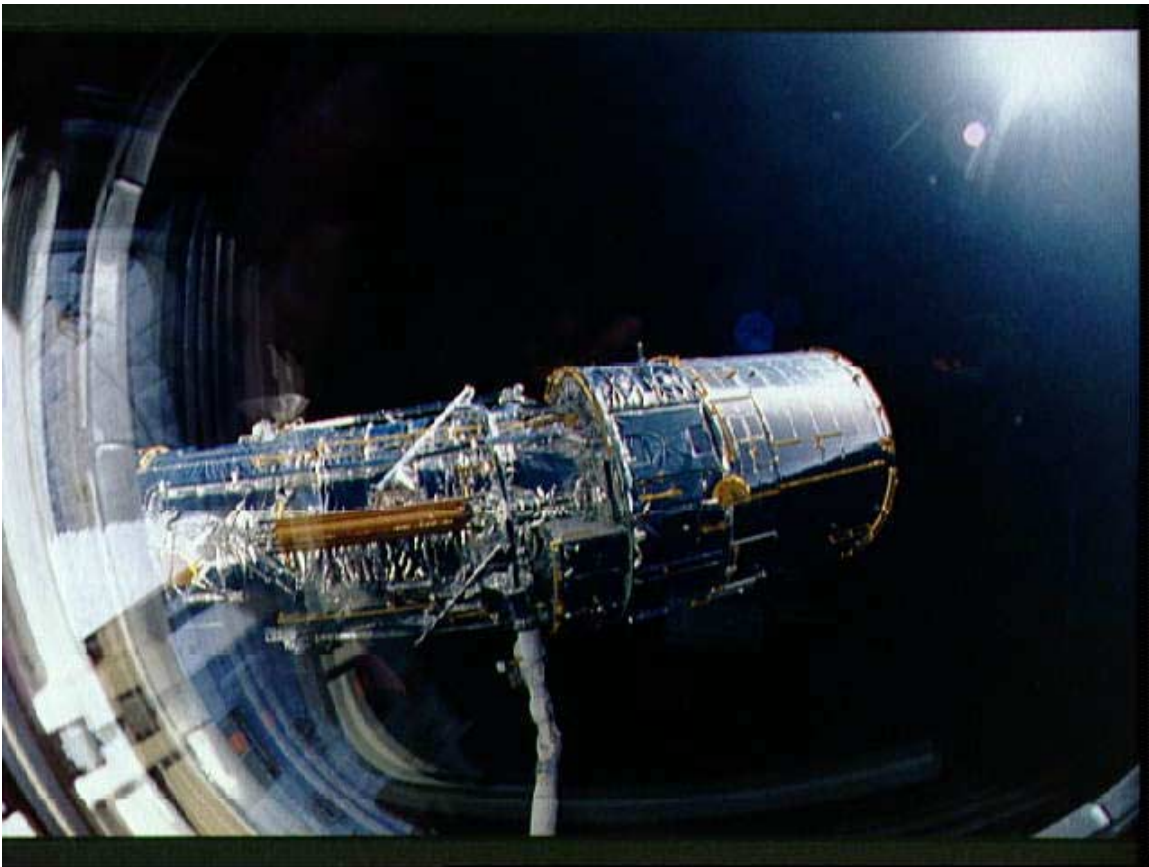

HST was placed in a 320 nautical mile circular orbit by the space shuttle in April 1990. The orbit is inclined at 28.5 degrees with respect to Earth's equator, and the time for a full revolution is 95 minutes. HST's position lies above the obscuring, absorbing Earth atmosphere, which to a greater or lesser extent plagues most observational programs carried out with ground-based telescopes. Although its 2.4-meter diameter mirror is only moderate in size, HST's superb optics and the lack of atmospheric distortion produce images which are close to the best possible allowed by the laws of physics for a telescope of its size. This "diffraction limited" image quality, when combined with complete access to the Ultraviolet—Visible—Infrared portions of the electromagnetic spectrum and the very dark on-orbit sky "background," allows HST to perform at its extraordinary level. The triumph of these advantages over a moderate size mirror is illustrated by the fact that HST

## STS-109

---

not only detects but also reveals morphological structure in extremely distant galaxies seen when the Universe was a small fraction of its current age. Ground-based telescopes, in spite of their often vastly superior size and numerous important contributions to astronomy, are unable to achieve comparable depth with resolution.

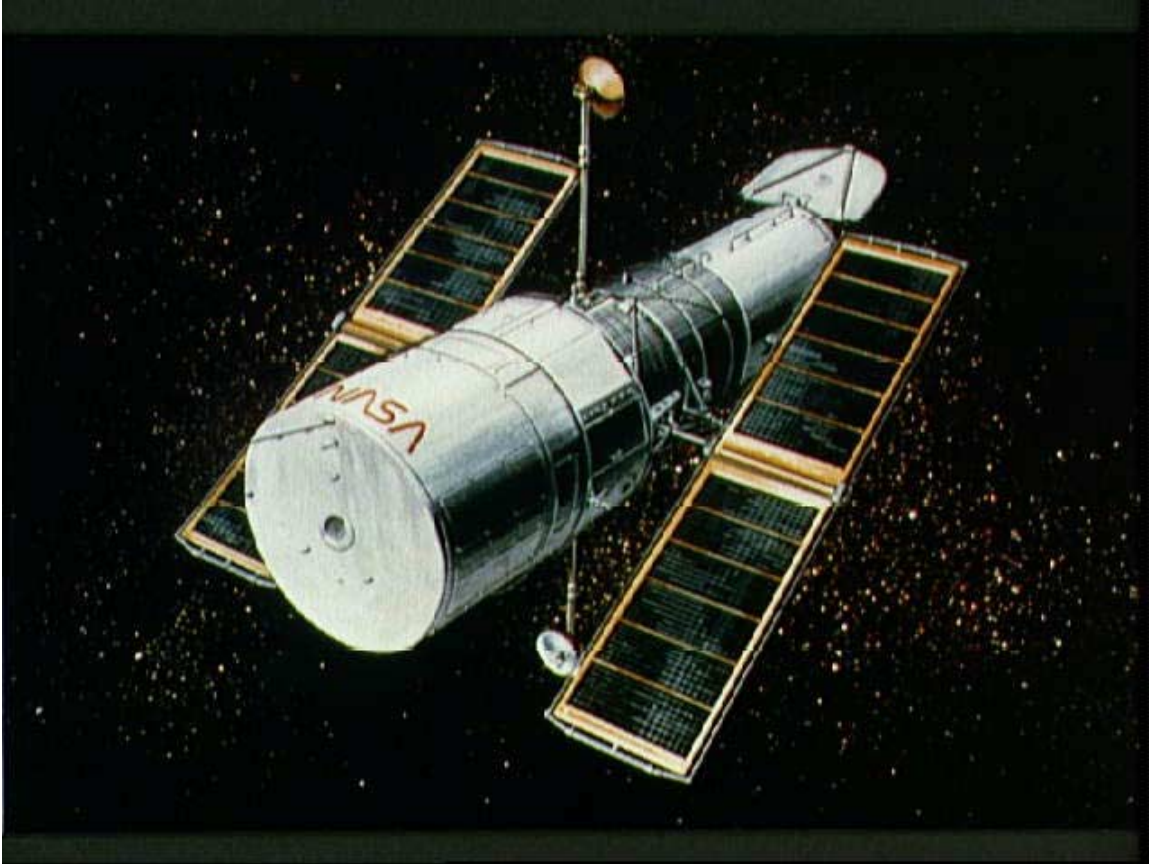

***An artist's concept of the Space Telescope***

From the beginning, NASA and the designers of HST had in mind a broadly capable observatory which could attack a wide variety of astronomical questions using a suite of diverse scientific instruments (SIs) collectively operating over a wide wavelength (color) range from the ultraviolet (UV) to the Infrared (IR). The most obvious breakdown of instruments is by basic type, e.g., imaging camera or spectrograph. Less familiar to the public than imagers, spectrographs decompose the light from astronomical targets into its separate wavelengths or colors, resulting in knowledge about an object's composition, temperature, pressure and motion. Imaging cameras are important for determining the morphology, structure, brightness and color of celestial objects.

HST has slots, or "bays," for five different SIs, and a key component of the 20-year program is that from time to time the instruments are replaced by newer, much more technologically capable SIs. The space shuttle and its crew of EVA astronauts are the means by which these new SIs—as well as replacement engineering hardware such as gyroscopes and solar arrays—are installed in HST. The Hubble program is now 12 years old, and on-orbit

# STS-109

---

servicing of the telescope has obviously been a key and irreplaceable element in the telescope's success. Highlights:

- The First Servicing Mission (SM1) in 1993 restored HST's optical acuity to the original expected levels and replaced its solar arrays
- With the installation of NICMOS and STIS during SM2 in 1997, HST observed the infrared sky for the first time and began taking detailed 2-dimensional spectra of black hole environments in the centers of galaxies
- SM3A in 1999 brought HST back on-line scientifically with the installation of a fresh set of gyroscopes, and upgraded its capabilities with a new computer

SM3B in February 2002 will be a very full, diverse mission, as both major scientific improvements and engineering maintenance and upgrades will be carried out. The next section of this document will discuss the scientific aspects of SM3B in more detail.

## **SM3B and SM4: Extending HST's Scientific Legacy**

When the astronauts leave Hubble behind in orbit after the final service call, SM4 in 2004, they will be leaving the observatory at the peak of its capabilities. Three new scientific instruments inserted in 2002 and 2004, the Advanced Camera for Surveys (ACS, inserted during SM3B), the Cosmic Origins Spectrograph (COS, SM4) and the Wide Field Camera 3 (WFC3, SM4), will be 10 to 20 times more powerful than their predecessor Hubble instruments. The insertion of the NICMOS Cooling System (NCS) in 2002 will restore Hubble's capability to take images in near-infrared light, and this capability will be dramatically strengthened with the WFC3 near-IR channel in 2004.

ACS has the potential to be 10 times more powerful in its view of the Universe than the current wide-field imager, WFPC2. It achieves this 10X performance as a result of a detector sensitivity which is five times greater than that of WFPC2 in the very important red region of the spectrum, and a field of view which has twice the area of WFPC2. An additional bonus is that ACS has twice the angular resolution that WFPC2 possesses over wide fields. Thus, the advantages are that: ACS will be able to detect faint objects much more quickly than WFPC2 could; will cover twice the sky area per exposure, which brings an important efficiency in mapping regions of the sky; will reveal morphological structure in smaller objects; and will detect distant galaxies and other dim objects significantly fainter than WFPC2 could in exposures of the same length. ACS will bring these advantages to bear in an extremely broad range of observing programs carried out by the astronomers who were granted telescope time in the last round of competitive proposal review. One thing seems certain: with ACS's installation we will have the capability of looking deeper into the Universe with greater clarity than we ever have before. Astronomers in large numbers have been looking forward to ACS's arrival for years, and that time is now at hand.

## STS-109

---

The NCS is a mechanical refrigeration system, or “cryocooler,” which will restore HST’s IR instrument, NICMOS, to full operational status. NICMOS entered a period of “hibernation” in January 1999, when its solid nitrogen ice coolant ran out. The instrument’s detectors, for a variety of reasons, need to be kept very cold to achieve adequate scientific importance. The two-year period during which NICMOS did operate showed the great advantages the infrared brings to HST science. First, many objects in the Universe are cool and radiate much of their light in the IR. Second, infrared light is much less strongly scattered by dust than is visible and ultraviolet light, which means that the IR is the color of choice when observing dusty environments such as the birthplaces of stars. Last, because the Universe is expanding, the UV and visible light from very distant galaxies is “redshifted” into the IR. If an astronomer wants a complete description of such a galaxy, it is therefore important to observe it over the entire UV-Visible-IR range of colors. In addition to the IR science, which the NCS will hopefully re-enable, the cryocooler will serve as a trailblazer for the applicability and function of mechanical refrigeration systems in space.





## Who Was Edwin P. Hubble?



*Edwin P. Hubble*

One of the great pioneers of modern astronomy, the American astronomer Edwin Powell Hubble (1889-1953) started out by getting a law degree and serving in World War I. However, after practicing law for one year, he decided to “chuck law for astronomy and I knew that even if I were second rate or third rate, it was astronomy that mattered.”

He completed a doctoral dissertation on the Photographic Investigation of Faint Nebulae at the University of Chicago and then continued his work at Mount Wilson Observatory, studying the faint patches of luminous “fog” or nebulae in the night sky.

Using the largest telescope of its day, a 2.5-m reflector, he studied Andromeda and a number of other nebulae and proved that they were other star systems (galaxies) similar to our own Milky Way.

He devised the classification scheme for galaxies that is still in use today, and obtained extensive evidence that the laws of physics outside the Galaxy are the same as on Earth—in his own words: “verifying the principle of the uniformity of nature.”

In 1929, Hubble analyzed the speed of recession of a number of galaxies and showed that the speed at which a galaxy moves away from us is proportional to its distance (Hubble’s Law). This discovery of the expanding Universe marked the birth of the “Big Bang Theory” and is one of the greatest triumphs of 20<sup>th</sup>-Century astronomy.

None other than Albert Einstein could have predicted Hubble’s remarkable discovery some 10 years earlier. In 1917, Einstein applied his newly developed General Theory of Relativity to the problem of the Universe as a whole. Einstein was very disturbed to discover that his theory predicted that the Universe could not be static, but had to either expand or contract. Einstein found this prediction so unbelievable that he went back and modified his original theory to avoid this problem. Upon learning of Hubble’s discoveries, Einstein later referred to this as “the biggest blunder of my life.”

## Hubble Space Telescope: A Great Observatory Continues Its Quest

### A Promise Fulfilled

A golden era of space exploration and scientific discovery began April 24, 1990, with the launch and deployment of NASA's Hubble Space Telescope (HST). This first of NASA's "Great Observatories" was carried into space aboard the Space Shuttle Discovery during the STS-31 mission, and was deployed on April 25, 1990.



*Gas Pillars in M16 - Eagle Nebula*

# STS-109

---

During its nearly 12 years of operation, and especially since the First Servicing Mission (SM1) in December 1993 restored its optical performance to expected levels, HST's unprecedented rapid-fire rate of discoveries has invigorated astronomy and instilled in the public a sense of wonder and an appreciation for scientific inquiry. HST has proven to be a remarkably diverse tool for examining planets, stars, star-forming and probable planet-forming regions of the Milky Way, distant supernovae, galaxies and quasars, and the hydrogen gas lying between the galaxies. Not since the invention of the telescope 400 years ago has our vision of the Universe been so revolutionized, and over such a short period of time. HST has been responsible for nothing less than a re-writing of the textbooks on astronomy and astrophysics.

The most technologically advanced scientific instruments HST will ever contain have not yet been installed in the telescope; these improvements will occur in the final two servicing missions, SM3B and SM4 (in 2002 and 2004), and will leave HST at the peak of its scientific capabilities for the last eight years of its life. Such technological growth leading to vastly increased scientific capability has been occurring since 1993, and is exactly what the mission architects envisioned decades ago when the HST program was born. Clearly, much of HST's best science lies yet ahead.

## **The Telescope and Its Operations**

The 12-ton HST observatory takes full advantage of its location in Earth orbit. Because the light from celestial targets reaches the telescope without traversing the atmosphere, it does not suffer from distortion (e.g., twinkling starlight), and the result is extremely sharp and detailed images of planets, stars and galaxies, in spite of HST's rather modest 8-ft (2.4 m) diameter primary mirror. A major advantage of observations from space is that the important ultraviolet and infrared regions of the electromagnetic spectrum are fully available for study, unlike the situation on the ground, where atmospheric absorption in those wavelength regions is a problem. Lastly, the night sky is significantly darker on-orbit than on the ground, and hence offers better contrast for detecting and studying faint objects such as extremely distant galaxies.

At any given time in its 20-year mission, HST contains up to five scientific instruments (SIs), and the collective set offers a broad range of capabilities in imaging and spectroscopy over a wide wavelength interval. The SIs all use on-board microprocessors, which issue the commands to execute pre-planned/stored observational programs. The heart of each instrument is its detector, an electronic device which converts light to electrical signals across its active area, and sends the data to HST's data recorders for later radio transmission to orbiting data relay satellites and, ultimately, the ground. One type of detector which is well-known due to its presence in camcorders is the Charge Coupled Device, or CCD, which in astronomy is most frequently used for visible light imaging and spectroscopy. Other features of SIs are filters and gratings, which for imaging and spectroscopic applications, respectively, select the wavelength range of the light the astronomer wants to detect and analyze. Spectroscopy—less well-known than imaging to non-scientists—is the study of an object's chemical composition, temperature, motion, and age by means of dispersing the light into its various colors or wavelengths.

## STS-109

---

Besides the scientific instruments, major elements of HST include: a central computer which coordinates the functions and relays the telemetry from the major subsystems aboard the telescope; a pair of solar arrays which extend from the sides of the telescope and generate the required electrical power for operating the SIs and the subsystems, and for charging the telescope's six batteries; a pair of high-gain antennas for receiving and transmitting data from/to relay satellites and ground stations; and a complex pointing control system for keeping the telescope extremely precisely and stably pointed at the target being observed. The importance of stable pointing can hardly be overemphasized. The superb imaging quality of HST requires extraordinary stability in order that jitter and image drift not produce significant image degradation during long exposures. A benchmark of HST's optical quality is that it can produce images of the outer planets in our solar system that approach the clarity of those from the Voyager flybys.

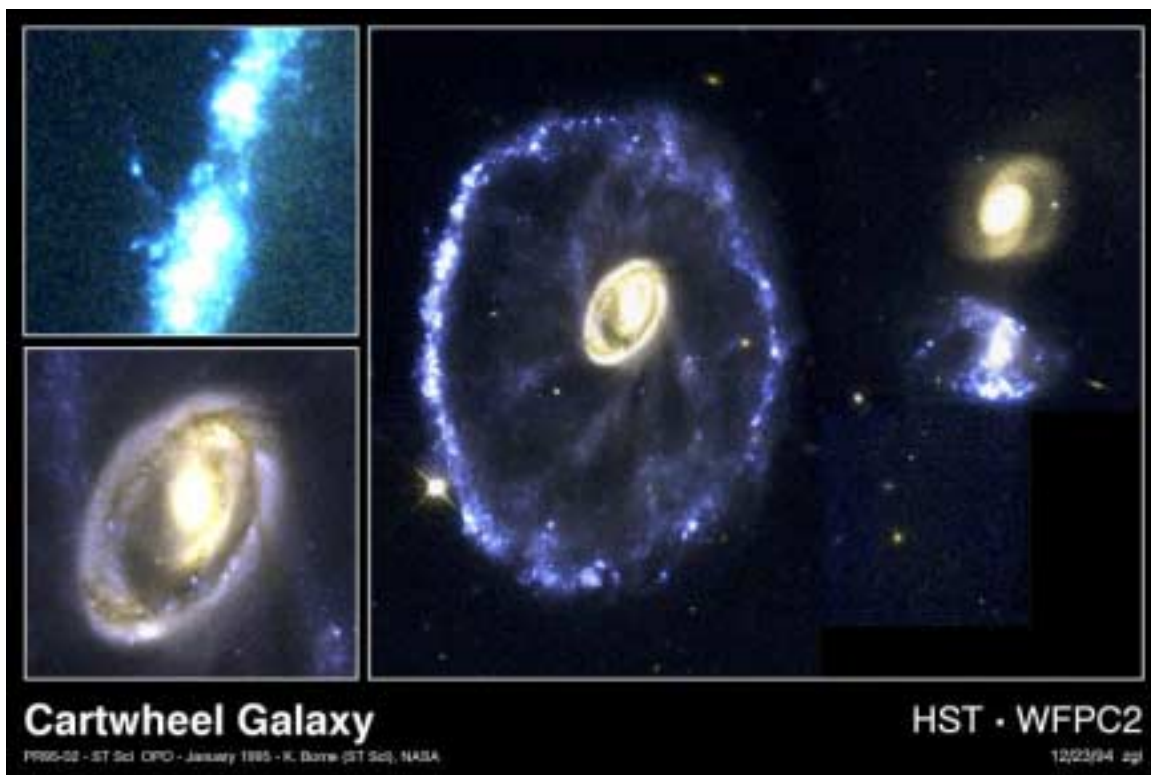

***A rare and spectacular head-on collision between two galaxies appears in this NASA Hubble Space Telescope true-color image of the Cartwheel Galaxy, located 500 million light-years away in the constellation Sculptor.***

HST operates around the clock, gathering information for teams of scientists who study virtually all the constituents of the Universe. Overall responsibility for HST, including the program to service and upgrade the telescope, resides with the HST Project at Goddard Space Flight Center (GSFC, in Greenbelt, Maryland). HST is controlled and receives commands from the Space Telescope Operations Control Center (STOCC), resident at the Space Telescope Science Institute (STScI) in Baltimore; STScI's major function is to plan and administer the science program of HST. A second STOCC at GSFC is used for

# STS-109

---

commanding HST during servicing missions. Every day, data obtained by HST streams through a series of satellite relays to the GSFC and then by telephone line to the STScl, where the raw data are converted into scientifically useable data, calibrated, and archived. The information collected daily by Hubble is stored on optical computer disks. The constantly growing archive of Hubble data is a unique scientific resource for current and future astronomers.

The observations carried out by HST result from an annual competitive process, conducted by the STScl, in which astronomers from around the world propose for observing time on the telescope. Recent observing cycles have seen submissions of more than 1,000 scientific proposals for time on HST. An indication of the importance of HST to astronomers is that many more proposals are submitted than can be accommodated. The “oversubscription factor” is typically in the range of 4X-6X; the current value is 8X. Clearly, the science programs executed by HST represent the cream of the crop of those proposed.

## **Servicing HST**

In addition to upgrading the telescope with new, dramatically improved instruments, servicing missions are critical for replacing aging and worn-out components, and hence keeping the telescope running smoothly. This latter maintenance function is exactly analogous to maintenance performed on one’s automobile, for example. Experience has shown that HST servicing missions should be carried out approximately every three years. Three missions—all extremely successful—have been flown to date: SM1 in December 1993; SM2 in February 1997; and SM3A in December 1999. Because HST’s gyroscopes needed to be changed out earlier than expected, the content of the original SM3 was divided up into two pieces—A and B—with SM3B coming in February 2002.

When the astronauts leave Hubble behind in orbit after the final service call, SM4 in 2004, they will be leaving the observatory at the peak of its capabilities. Three new scientific instruments inserted in 2002 and 2004, the Advanced Camera for Surveys, the Cosmic Origins Spectrograph and the Wide Field Camera 3, will be 10 to 20 times more powerful than their predecessor Hubble instruments. The insertion of the NICMOS Cooling System in 2002 will restore Hubble’s capability to take images in near-infrared light, and this capability will be dramatically strengthened with the Wide Field Camera 3 near-IR channel in 2004. The remaining two missions, SM3B and SM4, will complete the process of modernizing Hubble’s spacecraft and making it less prone to failures.

## **Hubble’s Major Contributions to Astronomy**

There is virtually no area of astronomical research that has not been profoundly affected by Hubble observations. Some of the highlights of Hubble’s scientific achievements to date include the following: Hubble

- Took the deepest views ever made of the visible Universe, revealing galaxies dating back to within a billion years of the Big Bang. These observations have opened up new areas of research into how galaxies form and evolve and what happened in the earliest days of the Universe. Astronomers are discovering that proto-galaxies in the early Universe were small irregular clumps which grew by colliding and merging, and which formed stars at a rapid rate.

## STS-109

---

- Precisely measured the current expansion rate of the Universe, a value sought for nearly 70 years since Edwin Hubble first discovered the Universe is expanding uniformly in all directions.
- Made the definitive observations showing that the Universe is destined to expand forever, and is even accelerating, apparently driven by “dark energy,” a mysterious repulsive form of gravity that is pervasive among the galaxies.
- Found that the Universe’s most powerful explosions, gamma-ray bursts, happen in distant galaxies in regions where massive new stars are rapidly forming. This links the gamma-ray bursts to the catastrophic deaths of super-massive stars.
- Discovered that super-massive black holes dwell in the cores of most galaxies. Specifically, black holes are found at the centers of galactic “bulges” – either elliptical galaxies or the central bulges possessed by most spiral galaxies. There is a very tight relation between the mass of the “bulge” and the mass of its central black hole. This implies a direct link between the growth of galaxy “bulges,” the growth of their black holes, and quasars, which occur when a massive black hole “swallows” more mass.
- Provided the clearest views ever of the diverse and complex processes at work in the birth and the death of stars. For newly forming stars these include the formation of accretion disks of gas and dust and the periodic ejection of material, focused into narrow jets by magnetic fields around the star. For stars that have exhausted their fuel sources at the end of their lives, Hubble has revealed the exquisite diversity of forms taken by the material ejected from the stars and how this relates to a star’s specific circumstances. Hubble has chronicled the spectacular changes in Supernova 1987a as its blast debris plows into material surrounding the star.
- Showed that the first embryonic steps in planet formation are common around many stars in the form of vast disks of gas and dust that should rapidly precipitate planets. However, many of these disks rapidly lose the gas (mostly hydrogen) they contain as they are bombarded by energy from nearby bright, massive stars in large star-forming regions. This suggests gas-giant planets like Jupiter or Saturn may be relatively rare in the Galaxy.
- Observed unique gap and ring structures within vast dusty circumstellar disks which are potentially attributed to the gravitational influence of large planets or protoplanets existing much farther from the parent star than found in our solar system. Interestingly, the analysis of some cometary orbits in the solar system also suggests the potential existence of a perturbing planet at a great distance from the sun.
- Provided stunningly clear views of the northern and southern lights on Jupiter, Saturn and Ganymede (a moon of Jupiter), as well as images of the electrical interactions between Jupiter and its satellite Io. Hubble provided the first visual evidence of major climate changes on the outer planets Uranus and Neptune and the first coarse map of the surface of Pluto.

## STS-109

---

Before the launch of Hubble in 1990, people referred to our “conscious expectation of the unexpected.” That was a sensible viewpoint, because as it has turned out, 40 percent of the highest-impact scientific achievements of Hubble were unanticipated. We cannot today anticipate very accurately what scientific problems will be most pressing five or six years from now. But we can anticipate that the Hubble Space Telescope will be deeply involved in the forefront of that science.

## Hubble Space Telescope Servicing Mission 3B

### Cost to Taxpayers

NASA's Hubble Space Telescope is the first observatory designed for routine maintenance, upgrade, and refurbishment on orbit. The program is planned as a 20-year mission with periodic servicing by shuttle astronauts. Hubble's modular design allows for more than 90 spacecraft components and all of the scientific instruments to be replaced on orbit. Servicing maintains the spacecraft, ensures operation at maximum scientific efficiency and allows for incorporation of new technology.

Hubble was launched on April 24, 1990, with a full complement of six scientific instruments. At that time, an inventory of spare HST hardware was available to support future servicing missions. Since launch, HST budgets have been sized to develop new instruments, to maintain the spare hardware, to sustain hardware expertise, to plan and develop servicing activities, and to test and integrate the payloads with the shuttle.



Due to gyroscope failures and the potential for interruption of the science program should another gyroscope fail, a servicing mission was needed as soon as replacement gyroscope hardware could be ready. Servicing Mission 3 (scheduled for June 2000) was divided into two flights --- Servicing Mission 3A (SM3A), successfully completed in December 1999, and



# STS-109

---

Servicing Mission 3B (SM3B), scheduled for early 2002. Much of the hardware planned for Servicing Mission 3 was not ready in time for the first flight, and will therefore be installed during SM3B.

## Servicing Mission 3B

The Advanced Camera for Surveys (ACS) will be added to Hubble's complement of already superb scientific instruments, further enhancing its imaging capability by a factor of 10. The Power Control Unit (PCU), which controls and distributes electricity from the solar arrays and batteries to other parts of the telescope, will be replaced. Hubble will get a brand new look with a new set of rigid solar arrays. Although one-third less solar cell area than the flexible first two pairs, they produce 20 percent more power. One of four reaction wheel assemblies (RWA), which is part of Hubble's pointing control system, will be replaced. Spin momentum in the reaction wheels moves the telescope into a commanded position and maintains it in this stable position.

Astronauts also will retrofit an existing but dormant instrument called the Near Infrared Camera and Multi-Object Spectrometer (NICMOS) with a new, experimental cooling system to return it to active duty. By fitting NICMOS with the experimental cryogenic system, NASA hopes to re-cool the NICMOS detectors, reviving its infrared vision, and extending its life by several years.

## Servicing Mission Costs – HST

### Planned Servicing Mission Hardware & Software

Advanced Camera for Surveys	76
Solar Array 3	19
NICMOS Cryocooler	21
Simulators/Testing	31
Ops/Software Development	25
Total (Millions)	172

For additional information contact:

Nancy Neal  
Goddard Space Flight Center  
Office of Public Affairs  
(301) 286-0039  
Internet: <http://www.gsfc.nasa.gov>

Don Savage  
NASA Headquarters  
Office of Public Affairs  
(202) 358-1600  
Internet: <http://www.nasa.gov>

## **Future of Hubble: Servicing Mission 4 and Beyond**

Plans for SM4 include two Science Instruments, which are currently in development. COSTAR will be removed during this servicing mission to make room for the Cosmic Origins Spectrograph, and Wide Field Camera 3 will replace the Wide Field and Planetary Camera 2. Also, a refurbished Fine Guidance Sensor will be installed leaving Hubble in optimum condition.

### **Cosmic Origins Spectrograph**

COSTAR will be removed and replaced with the Cosmic Origins Spectrograph (COS). COS is a spectrograph specifically designed to observe into the near and mid ultraviolet. The ultraviolet region is particularly interesting for observing high-energy activities such as are found in new hot stars and Quasi Stellar Objects. It is also a good region for viewing the composition and character of the Interstellar Medium.

### **Wide Field Camera Three**

Wide Field Camera Three (WFC3) will be the last main imaging camera. WFC3 will replace the current workhorse of Hubble, Wide Field and Planetary Camera 2. This upgrade will allow Hubble to maintain good imaging capabilities throughout the remainder of its mission. Everyone has seen the amazing pictures generated by the Wide Field and Planetary Cameras (1 and 2). WFPC2 was installed during the 1993 servicing mission and will be more than 10 years old when it is replaced by the WFC3.

### **Aft Shroud Cooling System**

This new system is designed to carry heat away from scientific instruments in the Aft Shroud area of the Telescope assembly and to allow the instruments to operate better at lower temperatures. The cooling system allows multiple instruments to operate simultaneously, helping the science team maintain the program's high productivity

### **Fine Guidance Sensor**

The Fine Guidance Sensors are systematically refurbished and upgraded. In “round-robin” fashion one FGS per servicing mission is being replaced. It is returned to the ground, disassembled and refurbished, and then taken back to Hubble on the next servicing mission to become the replacement unit for the next FGS to be serviced. By the conclusion of SM4 all three FGS’s will have been brought up to optimum condition in this manner.

### **Closeout Mission**

NASA will determine the best approach to secure the Telescope, upon the completion of Hubble’s 20-year mission. Currently there are several options being considered.

# STS-109

---

## Crew Bios

### Crewmembers

**Commander:** Scott Altman



Scott D. Altman, 42, a Navy commander, a former test pilot and veteran of two spaceflights, will command Columbia's STS-109 flight to the Hubble Space Telescope and be responsible for the mission's safety and success. He will fly Columbia through its rendezvous and capture of the space telescope on the 108<sup>th</sup> flight of the Space Shuttle Program, and will fly the shuttle during Hubble's release. He will be one of the three robotic arm operators on board Columbia. He will have primary responsibility for Earth observations, and will share responsibilities for the shuttle's guidance and navigation systems, computer systems and live support systems. He will land Columbia at the end of the mission.

Altman was pilot on STS-90, the 16-day Neurolab mission in April and May of 1998. He also was pilot on STS-106 in September 2000, a mission to prepare the International Space Station for the arrival of the Expedition One crew.

**Pilot:** Duane Carey



An Air Force lieutenant colonel and like his commander a former test pilot, Duane G. "Digger" Carey, 44, holds a master's in aerospace engineering from the University of Minnesota-Minneapolis. He will be responsible for a number of orbiter systems during ascent and landing. He will assist his commander in rendezvous, capture and later release of the Hubble Space Telescope. Other responsibilities include orchestrating the photographic and video graphic documentation of the mission. Carey also will be one of two medics aboard Columbia.

Carey, who was selected as an astronaut in 1996, is making his first space flight.

# STS-109

---

## **Mission Specialist 1: John Grunsfeld**



John M. Grunsfeld, 43, is the Payload Commander on STS-109 and is responsible for the payload operations and execution of the flight's five spacewalks. He holds a Ph.D. degree in physics from the University of Chicago, and served on the faculty of the California Institute of Technology where he did research in high-energy astrophysics and astronomy. He is making his second visit to service the Hubble Space Telescope. He and Richard Linnehan will be one of two space-walking teams that will alternate on consecutive days to make a total of five spacewalks to repair and upgrade the HST. Grunsfeld will make three spacewalks with fellow mission specialist Linnehan. They will serve as coordinators on the mission's other two spacewalks. Grunsfeld also will serve as ascent mission specialist and have responsibilities for opening and closing Columbia's payload bay door, computers, and EVA tools.

Grunsfeld, who was selected as an astronaut in 1992, is a veteran of three space flights. He first flew on STS-67, the second flight of the Astro observatory, a flight dedicated to astronomy research, which operated a suite of Ultra-Violet telescopes, in March 1995. He was a mission specialist on STS-81, a 10-day mission to the Russian space station Mir in January 1997, which also included a suite of experiments for biological research. On the STS-103 mission to service the Hubble Space Telescope, in December 1999, he performed two spacewalks.

## **Mission Specialist 2: Nancy Currie**



Selected as an astronaut in January 1990, Nancy Jane Currie, 43, holds a Ph.D. in industrial engineering from the University of Houston and is an Army lieutenant colonel. She served as a helicopter instructor pilot and is a Master Army Aviator. She accumulated over 4,000 flying hours in rotary and fixed-wing aircraft. She was robotic arm operator during STS-88, the first International Space Station assembly mission, and will be at the controls of Columbia's robotic arm during STS-109 capture and redeployment of the Hubble Space Telescope and during the five spacewalks to repair and upgrade it. She also will have responsibilities as the flight engineer aboard Columbia.

Currie is a veteran of three space flights, serving as a mission specialist and flight engineer on all of them. STS-57 in June of 1993 featured Spacehab microgravity experiments and return of the European Retrievable Carrier satellite. STS-70 in July 1995 deployed a NASA Tracking and Data Relay Satellite. STS-88 in December 1998 brought the first U.S. element, the Unity Node, to the space station.

# STS-109

---

## **Mission Specialist 3: Richard Linnehan**



Richard M. Linnehan, 44, a doctor of veterinary medicine, was selected as an astronaut in 1992 after service in the Army Veterinary Corps. Much of his service was with the Naval Ocean Systems Center in San Diego, where he served as chief clinical veterinarian for the Navy's Marine Mammal Program. On STS-109 he will team with Grunsfeld to do three spacewalks. He will be a coordinator for the flight's other two spacewalks. During the rendezvous, he will operate a handheld laser range-finding device, aiming it through the shuttle windows at the Hubble Space Telescope to provide Commander Altman with supplementary distance and closing rate information. Other responsibilities include opening and closing of Columbia's payload bay doors, serving as one of two medics on board and serving as entry mission specialist.

Linnehan has served as a mission specialist on two space flights. His first flight was STS-78, a 17-day Spacelab life sciences and microgravity studies mission in June and July 1996. He also flew on STS-90, the 16-day Neurolab mission in April and May 1998.

## **Mission Specialist 4: James Newman**



James H. Newman holds a Ph.D. in physics from Rice University and is a veteran of three space flights and four spacewalks. After graduation from Rice he did a year of postdoctoral studies there in atomic and molecular physics. Then, in 1985, he was named a Rice adjunct professor. That year he also began work at Johnson Space Center in crew and flight control team training in propulsion systems. He was named an astronaut in 1990. On STS-109 Newman will perform two spacewalks and be a coordinator for the mission's other three spacewalks. He is also responsible for post-insertion coordination and the on-board laptop computers.

Newman first flew on STS-51, a 10-day flight in September 1993, which deployed the Advanced Communications Technology Satellite and the Orbiting and Retrievable Far and Extreme Ultraviolet Spectrometer on the SPAS satellite. STS-69 was an 11-day mission in September 1995 that deployed and retrieved a SPARTAN satellite and the Wake Shield Facility. In December 1998, Newman performed three spacewalks on STS-88 / 2A, a 12-day mission that was the first assembly flight for the International Space Station.

# STS-109

---

## **Mission Specialist 5: Michael Massimino**



Michael J. Massimino, 39, received a doctorate in mechanical engineering in 1992 from Massachusetts Institute of Technology, where his work on human-operator-controlled space robotics systems resulted in two patents. After graduation he worked for McDonnell Douglas Aerospace in Houston and also served for three years as an assistant adjunct professor at Rice University. He became an assistant professor at Georgia Institute of Technology in 1995 and was selected as an astronaut in 1996. He will make two of the mission's spacewalks with James Newman and serve as a coordinator of the other three. He also will have backup robotic arm responsibilities.

Massimino is making his first space flight.

## Flight Day Summary Timeline

DATE	TIME (EST)	DAY	MET	EVENT
02/28/02	6:48:00 AM	1	000/00:00	Launch
02/28/02	7:33:00 AM	1	000/00:45	OMS 2 Burn
02/28/02	11:29:00 AM	1	000/04:41	NC1A Burn
02/28/02	12:16:00 PM	1	000/05:28	NC1B Burn
03/01/02	1:06:00 AM	2	000/18:18	NC2 Burn
03/01/02	5:28:00 AM	2	000/22:40	NPC Burn
03/01/02	10:29:00 AM	2	001/03:41	NH/NC3 Burn
03/02/02	12:36:00 AM	3	001/17:48	NC4 Burn
03/02/02	2:12:00 AM	3	001/19:24	Ti Burn
03/02/02	4:25:00 AM	3	001/21:37	HST Grapple
03/03/02	1:53:00 AM	4	002/19:05	EVA-1 Start
03/04/02	1:53:00 AM	5	003/19:05	EVA-2 Start
03/05/02	12:53:00 AM	6	004/18:05	EVA-3 Start
03/06/02	6:53:00 AM	7	005/19:05	EVA-4 Start
03/07/02	6:53:00 AM	8	006/19:05	EVA-5 Start
03/08/02	5:15:00 AM	9	007/22:27	HST Release
03/10/02	7:13:00 AM	11	010/00:25	HP Adjust
03/11/02	2:29:00 AM	12	010/19:41	Deorbit Burn
03/11/02	3:38:00 AM	12	010/20:50	Landing

## **Payloads**

### **Advanced Camera for Surveys**

With the addition of the Advanced Camera for Surveys (ACS), Hubble's new scientific instrument, astronomers will have the opportunity to discover celestial objects far beyond the reach of current instruments in a fraction of the time, unlocking more of the Universe's secrets. The ACS can survey a field on the sky twice as large as the original Hubble Deep Field, to the same exposure depth, three to four times faster than the camera that took the original Hubble Deep Field observations, the Wide Field and Planetary Camera 2 (WFPC2). A deep "core sample," looking back in time to shortly after stars and galaxies began to form, requires about 10 days of dedicated Hubble observing with the WFPC2, but less than three days with the ACS. This higher efficiency will allow Hubble to survey more areas of the sky or perform additional scientific observations in the same amount of time, greatly improving the productivity of this precious astronomical resource.

Astronauts will install ACS into the location currently held by the Faint Object Camera—the last of Hubble's original instruments. ACS will become Hubble's new workhorse, surveying far regions of the Universe, searching for extra-solar planets, and observing weather and other features on planets in our own solar system. With its wider field of view, superb image quality, and exquisite sensitivity, ACS will take full advantage of Hubble's unique position as a space-based telescope. This instrument is sensitive to wavelengths ranging from ultraviolet to the far red (115-1050 nanometers).



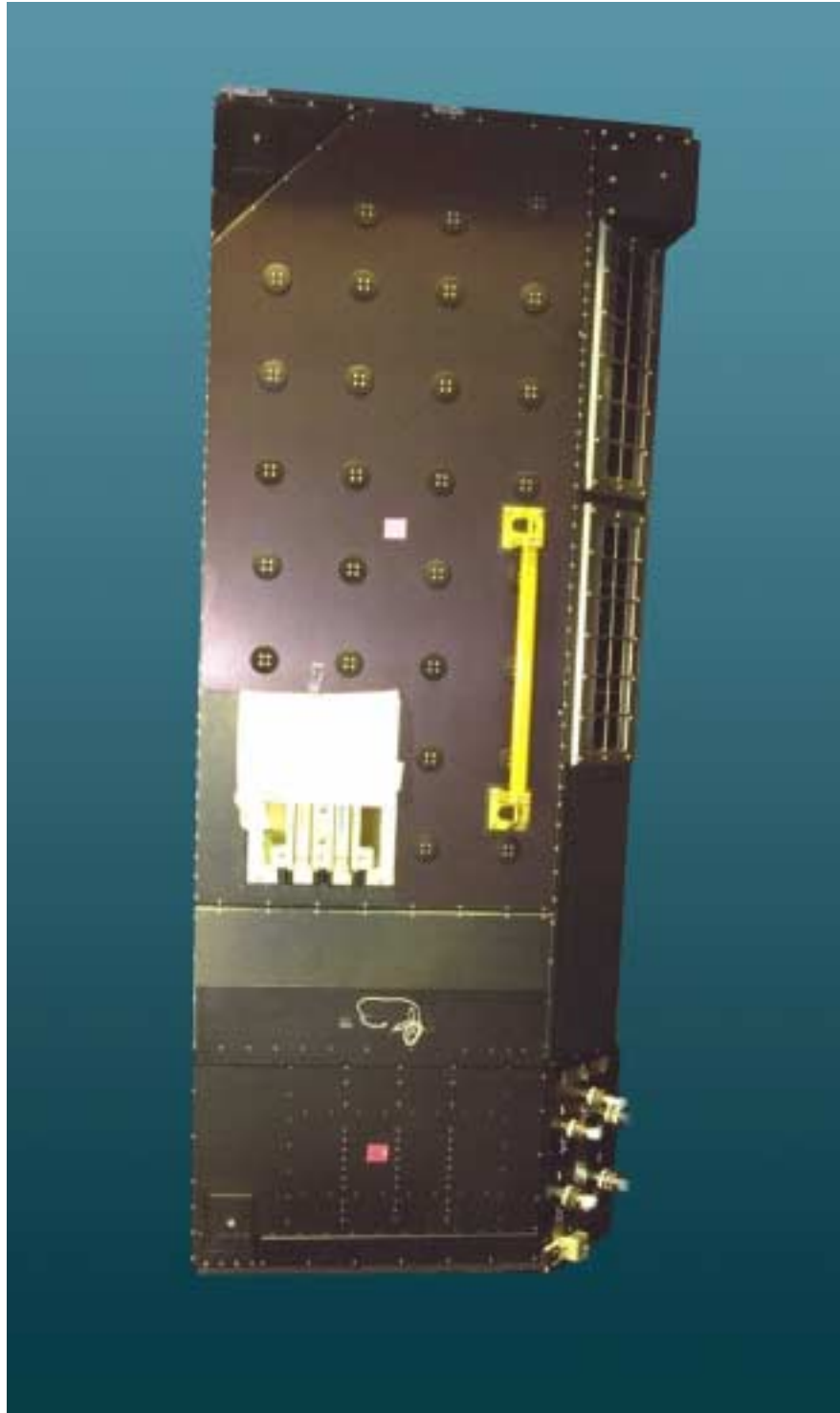

ACS is a large phone-booth-sized instrument consisting of three different, specialized channels. Each channel plays a unique imaging role, enabling ACS to contribute to many different areas of astronomy and cosmology. The ACS was manufactured by Ball Aerospace and Technologies Corp. in Boulder, Colo.

## **Wide Field Channel: Surveying the Universe**

The Wide Field Channel will conduct vast sky surveys to study the nature and distribution of galaxies. It was designed with a wide field of view to search for galaxies and clusters of galaxies in the early Universe, helping astronomers understand how our Universe evolved. Its field of view is Hubble's largest ever--more than twice the size of Hubble's current surveyor, WFPC2.

ACS's Wide Field Channel holds two state-of-the-art, 8-million pixel detectors called charge coupled devices (CCDs). These CCDs collect the light from astronomical objects and record their images. Designed to collect the most light in the shortest time possible, the Wide Field Channel uses highly reflective, silver-coated mirrors and an enhanced anti-reflection coating on its CCD detectors. This design allows this channel to collect four and a half times more light in a given exposure time than any of its predecessors. The Wide Field Channel is optimized to detect red light (600-800nm), which allows it to observe very old, very distant objects whose spectra are red-shifted due to the expansion of the Universe.

## **High Resolution Channel: Capturing the Details**

The High Resolution Channel will take extremely detailed pictures of the inner regions of galaxies, and search neighboring stars for planets and planets-to-be. This channel uses a one-million-pixel CCD, and a coronagraph to suppress light from bright objects, enabling astronomers to view nearby faint objects. Scientists will use this capability to examine the galactic neighborhoods around bright quasars.

The High Resolution Channel will also polarize and disperse light. These functions will allow Hubble users to study light in the centers of galaxies with massive black holes, as well as ordinary galaxies, star clusters, and gaseous nebulae.

## **Solar Blind Channel: Seeing in Ultraviolet**

The Solar Blind Channel is sensitive to only the shorter wavelengths of ultraviolet light. Some features—such as emission lines that indicate the presence of certain molecules—can be detected only in the ultraviolet portion of the spectrum. The Solar Blind Channel uses a highly sensitive photon-counting detector to enhance the visibility of these features. It will search for hot stars and quasars, and will study aurora and weather on planets in our own solar system.

## Payloads

### Power Control Unit

The Power Control Unit (PCU) is Hubble's power switching station. As the central controller of the telescope's electrical system, it regulates and distributes the power Hubble needs to operate.

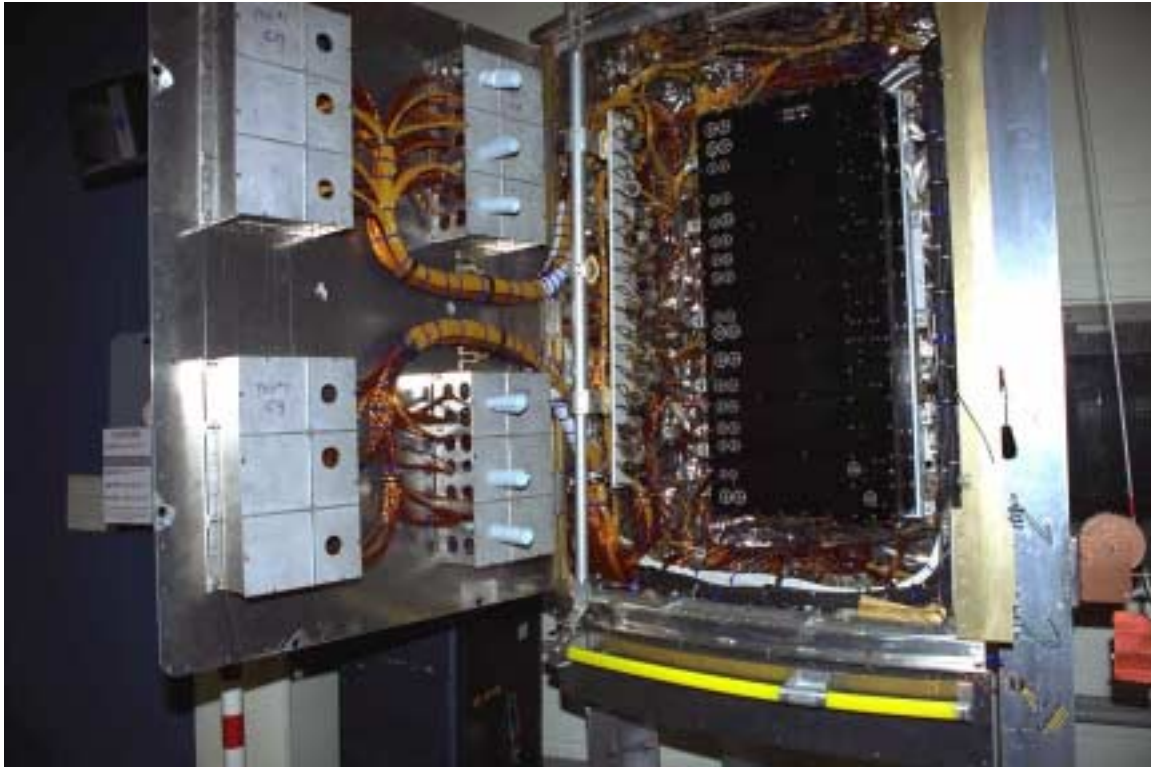

***Shown open here, the Power Control Unit will be replaced on this mission, requiring Hubble to be powered down.***

Hubble's solar arrays collect sunlight and convert it into electrical energy. The PCU distributes this energy from the solar arrays to the batteries and electrical components on Hubble, including the science instruments. The electrical energy stored in the six on-board batteries is used when Hubble travels into the Earth's shadow each orbit. The PCU also safeguards Hubble from power spikes and controls battery charging.

The new PCU replaces the original flight unit in Bay 4 of the telescope. It weighs approximately 160 pounds and measures 45 in. x 24 in. x 12 in. Designed and built by Lockheed Martin Space Systems in Sunnyvale, Calif., the new PCU is the original flight spare built for Hubble. This unit has been modified and retested to ensure optimal performance, and to enhance ease of installation by the astronauts.

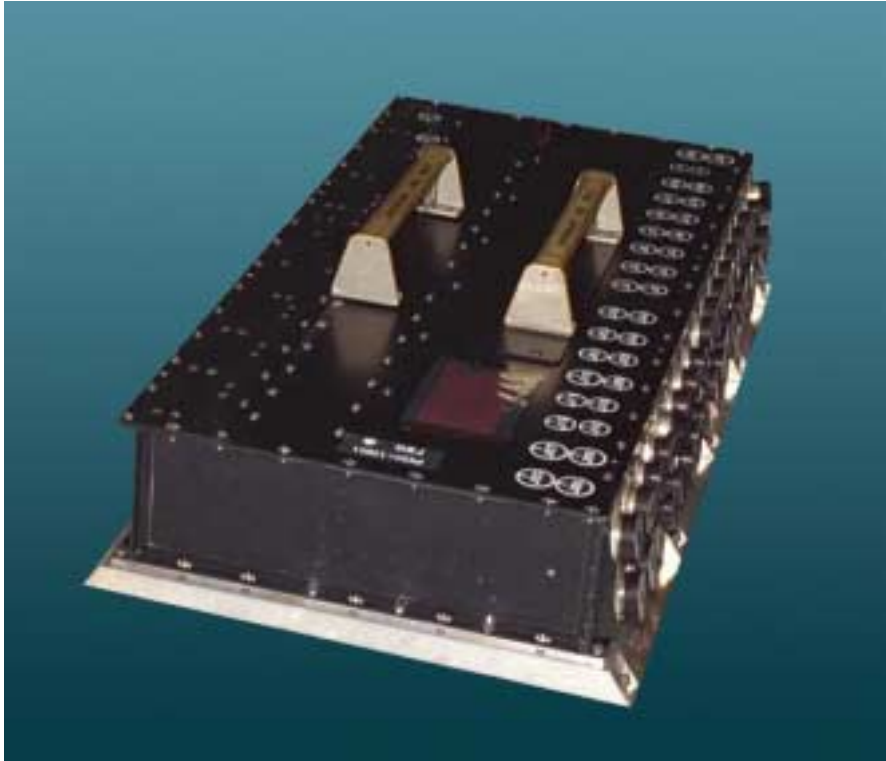

The original PCU has been on the job continuously since Hubble's launch in 1990 and had experienced normal degradation as it aged. Several relays that control battery charging and power distribution have failed and an electrical joint in the box has loosened, causing a slight loss of power and a risk of battery overheating. With Hubble's mission extended to 2010, a fresh PCU will enable Hubble to remain healthier and more productive throughout its lifetime.

The telescope's planners did not originally design the PCU to be replaced. Late in the building of Hubble, engineers made minor modifications to create a somewhat more astronaut-friendly PCU. Nevertheless, replacing the PCU will be a challenging spacewalk. Astronauts must disconnect 36 connectors on the original PCU and reconnect them to their proper mates on the new unit. The change-out of the PCU requires Hubble to be powered off for the first time since its launch in 1990. All telescope subsystems, including thermal control, will be turned off during this time.

## Payloads

### NICMOS Cryocooler

During the mission, astronauts will install a new cooling system, the NICMOS Cryocooler, onto the Near Infrared Camera and Multi-Object Spectrometer (NICMOS), which has been dormant since January of 1999.

Installed on Hubble in February of 1997, NICMOS used infrared vision to explore dark, dusty regions of space with precise optical clarity. Its infrared detectors operated at a very cold temperature (minus 352 degrees Fahrenheit, which is minus 213 degrees Celsius, or 60 degrees Kelvin). NICMOS was encased in a container filled with solid nitrogen ice to keep the detectors cold. A small heat leak caused the nitrogen ice to be consumed more quickly than planned.



***The NICMOS Cooling System will allow Hubble's Near-Infrared Camera to be reactivated.***

Scientists and engineers at NASA's Goddard Space Flight Center in Greenbelt, Md., devised the NICMOS Cryocooler, a state-of-the-art cryogenic cooler that is expected to return NICMOS to active duty. Creare Inc., Hanover, N.H., manufactured the tiny turbo-machinery.

## STS-109

---

By using non-expendable neon gas as a coolant, this closed system delivers high cooling capacity, extremely low vibration and high reliability. It uses a miniature cryogenic circulator to remove heat from NICMOS and transport it to the cryocooler. At the heart of the cooler is a turbo-machine consisting of a compressor that uses a tiny turbine turning at up to 400,000 rpm (about 100 times the operating speed of a typical car engine). The NICMOS Cryocooler is virtually vibration-free—an important aspect for Hubble since vibrations affect image quality.

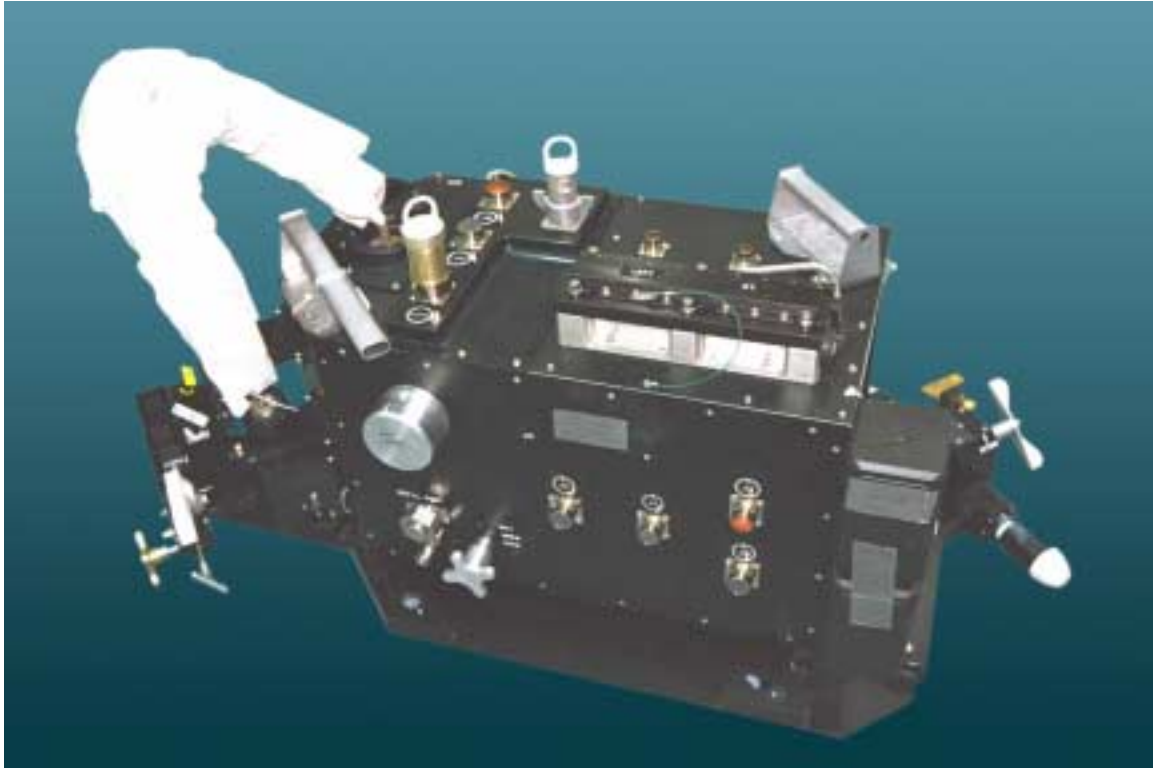

The new cryogenic system is expected to re-cool the NICMOS infrared detectors to about minus 334 degrees Fahrenheit (minus 203 degrees Celsius or 70 degrees Kelvin). This is an ideal temperature for the detectors and will make NICMOS more sensitive to incoming light.

This new technology was successfully demonstrated in 1998 aboard the Space Shuttle Discovery on STS-95. Retrofitting NICMOS with the new cryocooler can potentially double the instrument's lifetime.

## Payloads

### Hubble's New Solar Arrays

Astronauts will give Hubble a new look and boost its power when they install new solar arrays on the telescope. Unlike Hubble's first two pairs, which are so flexible that they roll up like window shades, Hubble's newest solar arrays are flat and rigid and fold up rather than roll up.

The new arrays have one-third less solar cell area, but produce 20 percent more power than the current set. The added power enables all the science instruments to be powered and ready to operate simultaneously, allowing for more discoveries in less time.

The high efficiency solar panels have supporting frames made of aluminum-lithium, which is stronger and lighter than the type of aluminum commonly used in spacecraft construction. The supports are less sensitive to the extreme temperature changes of Hubble's harsh environment.

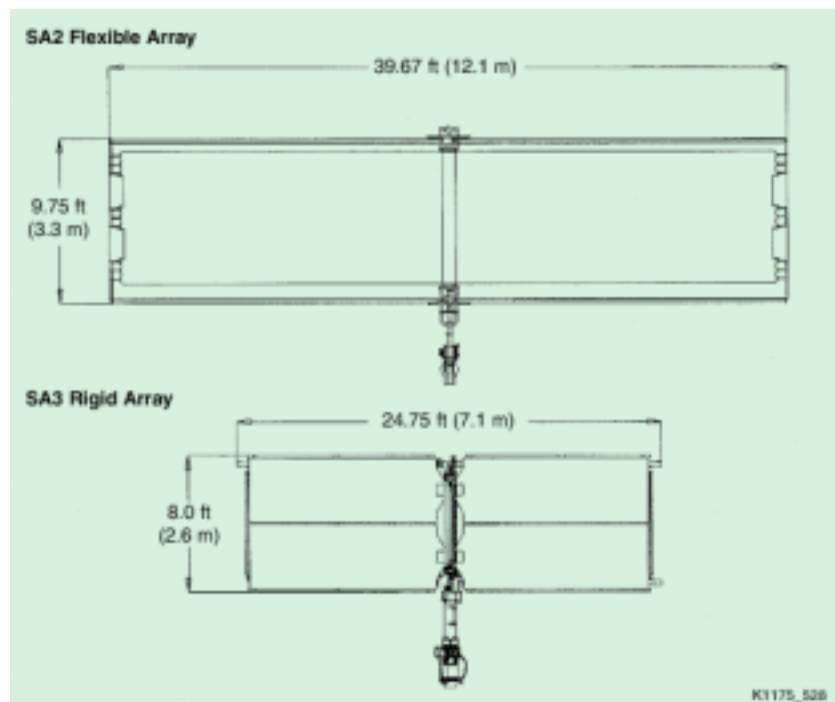

Item	Power	Size	Weight	Comments
SA2 Flexible Array	4800 W at 6 years (actual)	39.67 ft x 9.75 ft (12.1 m x 3.3 m)	339 lb per wing	Actual on-orbit performance measured at Winter Solstice, December 2000
SA3 Rigid Array	5270 W at 6 years (predicted)	24.75 ft x 8.0 ft (7.1 m x 2.6 m)	640 lb per wing	Increased capability for planned science  Less shadowing and blockage

K1175\_526A



***One wing of Solar Array 3 is lowered into a chamber for testing.  
The new rigid arrays will produce 20 percent more power.***



## STS-109

---

During each 97-minute orbit, Hubble spends about two-thirds of its time in searing sunlight and the other third in the frigid darkness of Earth's shadow. The rapidly cycling conditions cause the temperature of the solar panels to fluctuate between minus 94 degrees Fahrenheit (minus 70 degrees Celsius) and 187 degrees Fahrenheit (86 degrees Celsius). The solar arrays reach their hottest temperature just 10 minutes after leaving the chill of Earth's shadow.

Such dramatic, repeated temperature changes can cause tiny vibrations and movements within a spacecraft's solar array structure. If these movements are large enough, they cause motion of the main body of the telescope, and may affect the sensitivity of Hubble's pointing control instruments and interfere with long-term science observations.

The smaller, stiffer arrays are easier for the astronauts to work around during servicing missions—easier to fold up and move out of their way. In addition, their smaller size decreases on-orbit drag and slows the rate at which Hubble's orbit decays. Over time, all low Earth orbiting satellites feel the effects of atmospheric drag and lose altitude. The new arrays will slow that rate of altitude loss.

The Hubble program bought the new solar panels from the production line of a commercial system of communications satellites. At NASA's Goddard Space Flight Center in Greenbelt, Md., four of these panels were attached to an aluminum-lithium support wing structure to create each of the complete structures called "wings." A total of eight panels were used in the construction of these two wings. Goddard Hubble team members fabricated the support wing structures, the composite mast assembly, and the electrical assembly for these wings.

The European Space Agency (ESA) built Hubble's first two sets of solar arrays. For the newest pair, ESA designed, developed and tested the Solar Array Drive Mechanisms, which maneuver the arrays to keep them constantly pointed at the Sun.

## Payloads

### Reaction Wheel Assembly

One of four reaction wheel assemblies (RWAs), which are an important part of Hubble's Pointing Control Subsystem (PCS), will be replaced by a new unit on SM3B. Reaction wheels and their associated electronics are packaged as RWAs. The RWAs use rotational, or angular momentum, to move the telescope from one target to another (this motion is called "slewing"), and to keep it pointed steadily once the target is acquired in the aperture of the observing scientific instrument.



***Reaction Wheel Assembly***

The flywheel inside each RWA can spin at speeds up to 3,000 revolutions per minute. Three RWAs are required for scientific operations, but the PCS system works better if all four wheels are operating. In particular, the slew times are reduced if four, rather than three, wheels are functioning, thereby improving Hubble's observing efficiency.

On Nov. 10, 2001, one of Hubble's four reaction wheels (RWA1) experienced a seven-minute telemetry dropout during which the wheel's rotation speed was unknown both to the automated systems on board Hubble and to engineers on the ground. Associated with this event were two brief disturbance torques to the telescope itself. Telemetry resumed at the end of the seven-minute period, and there have been no further anomalies in the wheel. Hubble continues to function well and was not damaged during the seven-minute event.

Because of the importance of reaction wheels to the telescope's performance, and taking into account the two-year time period between SM3B and SM4, it was decided to add a spare RWA to the manifest of SM3B. The STS-109 astronauts will swap out RWA1 with the new RWA during the second spacewalk, or EVA.

## Rendezvous

### **Hubble Space Telescope Rendezvous, Capture, Berthing and Deploy**

Columbia's rendezvous with the Hubble Space Telescope actually begins with the precisely timed launch of the shuttle on a course for the orbiting telescope. During the first two days of the mission, periodic engine firings will gradually bring Columbia to a point about 9 ½ statute miles behind the telescope, the starting point for a final approach to the observatory.

Before the approach, Mission Control, Houston, in concert with the Space Telescope Operations Control Center at the Goddard Space Flight Center in Greenbelt, Md., will command the telescope to stow the High Gain Antennas and close the aperture door. About 2 ½ hours before the planned capture time on Flight Day Three, Columbia will reach that point about 50,000 feet – 9 ½ statute miles -- behind HST. At that time, Columbia's jets will be fired in a Transition Initiation (TI) burn to begin the final phase of the rendezvous. Columbia will close the final miles to the telescope during the next orbit of Earth. About five minutes before the terminal initiation burn, Mission Specialist Nancy Currie will power up Columbia's robotic arm, releasing it from its latches along the left-hand edge of the shuttle's payload bay.

As Columbia closes in the final miles, the shuttle's rendezvous radar system will begin tracking HST and providing range and closing rate information to the crew. During the approach toward the telescope, the shuttle will have an opportunity to conduct four, small mid-course corrections at regular intervals. As the shuttle closes in, Currie will maneuver the robotic arm up above the payload bay of Columbia to a position where it is poised to latch on to a capture fixture on the telescope.

Just after Columbia's fourth small course correction engine firing is completed, the shuttle will reach a point about a half-mile below the telescope. At that time, about an hour before the scheduled docking, Commander Scott Altman will take over manual control of the approach. During the rendezvous, Pilot Duane Carey will assist Altman with navigation. Mission Specialist Rick Linnehan will operate a handheld laser range-finding device, aiming it through the shuttle windows at the telescope to provide Altman with supplementary distance and closing rate information. Mission Specialist Jim Newman will oversee a laptop computer program aboard Columbia, fed by real-time navigation information, which will provide Altman with additional cues to aid in controlling his approach.

Altman will slow Columbia's approach and fly up toward the telescope. When he is within 1,500 feet of the observatory, Altman will switch the shuttle's thrusters to a mode called "low-Z." In that mode, jets offset to the direction of the telescope are fired to continually slow the shuttle's approach, avoiding potential contamination of HST by shuttle jet exhaust. As Columbia moves within 600 feet of HST, it will approach the telescope at less than a half-mile per hour. As the distance between Columbia and HST decreases to about 200 feet, the space telescope operations ground crew will command HST to perform a final roll maneuver to position itself for capture. The telescope's solar arrays will remain fully

## STS-109

---

deployed parallel to Hubble's optical axis. The shuttle will creep toward the observatory as it closes the final 100 feet, moving at a speed of only a few feet per minute.



Altman will fly Columbia to within 35 feet of the telescope and hold position while Currie, using a view from a camera mounted at the end of the robotic arm to gauge alignment, latches on to the telescope.

Using views from a camera centered in the ring where the telescope will be berthed in the shuttle bay, Currie will then lower HST into a special cradle, called the Hubble Space Telescope Flight Support System, in Columbia's payload bay. The telescope will be latched to the FSS for the duration of the servicing work. An umbilical from Columbia will be remotely connected to HST to provide transmission of electrical power from the shuttle to the telescope. Then, Altman will maneuver the shuttle to allow HST's solar arrays to track the sun, fully charging the telescope's batteries.

About 4 ½ hours after HST is captured, once the batteries are fully charged, commands will be sent to retract the telescope's solar arrays. During the servicing work, the HST FSS cradle can be rotated and pivoted as needed to provide the best available access to various worksites for spacewalkers or to prepare for a reboost of the telescope by Columbia. About 4 ½ hours after HST is captured, commands will be sent to retract the telescope's solar arrays for a final time.

# STS-109

---

## **Hubble Space Telescope Deploy**

The Hubble Space Telescope is planned to be released from Columbia on Flight Day Nine of the mission. About three hours before the planned release time that day, Currie will power up Columbia's robotic arm and latch on to the grapple fixture on the telescope. Telescope controllers will send commands to redeploy the high gain antennas. Columbia will be maneuvered to allow the new solar arrays to fully charge the HST batteries. About two hours before release, the telescope will be switched back to its own internal power and the umbilical attaching the telescope to Columbia's power system will be remotely disconnected.

Then, the three latches that secure the telescope to the FSS in Columbia's payload bay will be released and Mission Specialist Michael Massimino, at the controls of the shuttle's robotic arm, will slowly maneuver the observatory to a point high above the shuttle bay. He will then hand robot arm operations to Currie. Columbia's steering jets will be turned off to avoid any possible disturbance as Currie commands the arm to release the telescope's fixture. Then, about a minute later, the shuttle jets will be turned back on and fired, again in the Low-Z mode to avoid contamination, to slowly back Columbia away. Another jet firing will be performed about a half-hour later to continue Columbia's separation from the vicinity of HST.

## Spacewalks

### STS-109 Extravehicular Activity

Astronauts John Grunsfeld, Rick Linnehan, Jim Newman and Michael Massimino will team up during STS-109 to perform five spacewalks, or Extravehicular Activities (EVAs), on consecutive days to maintain and upgrade the Hubble Space Telescope. The astronauts will perform the spacewalks in pairs on alternating days, providing each team a day to rest between ventures outside the shuttle. Grunsfeld and Linnehan will perform the first, third and fifth spacewalks. Newman and Massimino will perform the second and fourth spacewalks. Although not scheduled, resources are planned to be available for a sixth spacewalk to be conducted if needed to complete the planned telescope servicing tasks.

For all of the spacewalks, Astronaut Nancy Currie will serve as prime robotic arm operator from controls in Columbia's aft cockpit. Commander Scott Altman will be her backup. Currie will maneuver the arm to position the spacewalkers, one of whom will be working in a foot platform at the end of the arm the majority of the time. During the work outside, the astronauts can be identified by the markings on their spacesuits.

#### **Recognizing the spacewalkers:**

Grunsfeld, Extravehicular Crewmember 1 (EV1) -- solid red stripes on suit

Linnehan, EV2 -- solid white suit (no stripes)

Newman, EV3 -- horizontal broken red stripes

Massimino, EV4 -- diagonally broken red stripes

#### **Spacewalk Number One, Flight Day Four: Replace -V2 Solar Array and Diode Box Assembly, Install Diode Box Controller Cross Strap Harness**

Grunsfeld and Linnehan will begin the spacewalks with the first excursion outside of Columbia planned to occur on Flight Day Four of the mission, the day after Columbia captures the telescope. Planned to last 6 ½ hours, the first spacewalk will include the replacement of one of the telescope's two second-generation solar arrays (SA2), the array that will be on Columbia's starboard side as the telescope is oriented in the shuttle bay. Both of the solar array wings will have been retracted the day before, about 4 ½ hours after the telescope is latched in the shuttle payload bay. The SA2 array will be replaced with a third-generation array (SA3) that is more powerful and more durable. During most of the solar array work, the first 4 ½ hours of the spacewalk, Linnehan will be working from the foot platform at the end of Columbia's robotic arm. After that, Grunsfeld will work from the end of the arm and Linnehan will work free-floating.



***John Grunsfeld uses virtual reality hardware at the Johnson Space Center to rehearse some of his Hubble servicing tasks.***

To begin, Grunsfeld does various tasks to prepare for that day's servicing activities. These include deploying the Axial Science Instrument Protective Enclosure (ASIPE) mini-Translation Aid (TA), deploying the port and starboard TAs as required, removing the Manipulator Foot Restraint (MFR) from its stowage location and installing it on the RMS grapple fixture, installing the Low Gain Antenna Protective Cover (LGAPC), removing the Berthing and Positioning System (BAPS) Support Post (BSP) from its stowage location and installing it on the Flight Support System (FSS), and inspecting the P105 and P106 umbilical covers. Meanwhile, Linnehan brings out of the airlock the Crew Aids and Tools (CATs) and installs the MFR handrail to the MFR on the RMS.

The BSP is required to dampen the vibration that the servicing activities will induce into the deployed SAs. Before the BSP installation, the crew will pivot the support structure to bring HST to an 85-degree angle. The two center push-in pull-out (PIP) pins are installed each day and removed each night in case the shuttle must make an emergency return to Earth. Grunsfeld removes the BSP from its stowage position in the FSS cradle, and then installs one end to the BAPS ring with a PIP pin and the aft end to the FSS cradle with another PIP pin. Finally the BSP is commanded to its 90-degree limit and the two center PIP pins are installed.

After the initial setup, the spacewalkers will replace the -V2 Solar Array and Diode Box Assembly on the Telescope. They will also install the Diode Box Controller (DBC) cross-strap harness. First, Grunsfeld, who is free floating, retrieves the HST PFR and APE and

## STS-109

---

transfers them to Linnehan in the MFR. Linnehan moves to the HST and installs the PFR on HST foot restraint receptacle eight for Grunsfeld to use. Grunsfeld translates to the RAC to retrieve the DBC cross-strap harness and a Portable Connector Tray, and temporarily stows them on the telescope. Then he ingresses the PFR. Together the astronauts retract the -V2 SA2 Primary Deployment Mechanism (PDM). Grunsfeld then engages the PDM lock and installs the Portable Connector Tray. While still in the PFR, Grunsfeld demates the SA2 connectors from the DBA while Linnehan retrieves the WFPC Cover and installs it on the -V3 Aft Shroud in support of the PCU change-out on spacewalk number three.

Next the astronauts remove the -V2 SA2 from the Telescope. They disengage the Solar Array Drive Adapter (SADA) Clamp, remove SA2, translate it to the RAC and install it on the starboard shelf via the SADA Clamp and forward constraint PIP pin mechanical attachments.

Grunsfeld translates back to the telescope and removes the -V2 DBA by disengaging the remaining X-connector drive mechanism and releasing the four J-hook bolts while Linnehan retrieves the DBA2 from the RAC and carries it to Grunsfeld at the telescope worksite. The astronauts swap hardware and Grunsfeld installs the DBA2 on the telescope while Linnehan translates to the RAC with the DBA and installs it and closes its thermal cover. Grunsfeld installs the DBC cross-strap harness onto the telescope and mates it to the -V2 DBA2.

With the DBA2 now installed on the telescope, the astronauts begin the installation work for the new, third-generation solar array (SA3). Both translate to the RAC. Linnehan disengages Latch 5, deploys the mast and engages the two mast bolts. Grunsfeld ingresses the aft PFR, releases and pivots Latch 3 to clear the tang, disengages the two tang bolts, stows the tang and engages the two tang bolts. Linnehan disengages Latch 2. Grunsfeld pivots Latch 3 to the stowed position and installs the PIP pin, deploys the MLI flap over the tang interface and releases Latch 4. Grunsfeld stabilizes SA3 while Linnehan releases Latch 1. The astronauts then remove SA3 from the RAC.

Both crewmembers install SA3 onto the telescope by properly orienting SA3 and inserting the SADA into the SADA Clamp until the three soft dock tangs engage. Grunsfeld engages the SADA Clamp closed and mates the SA3 electrical interfaces. Linnehan translates back to the RAC and performs the SA2 closeout work, engaging the aft latch, the forward latch and the two forward constraint bolts.

Then the astronauts deploy the SA3 panel, engage the panel locking bolts and release the SA3 brake. Grunsfeld routes the DBC cross-strap harness to the +V2 side, removes the HST PFR and temporarily stows it on the ASIPE, and removes and stows a Portable Connector Tray on the RAC. Meanwhile, Linnehan maneuvers to the -V3 aft shroud and installs the two FHST covers in preparation for the PCU change-out on spacewalk three.

At this time, the astronauts switch places: Grunsfeld ingresses the arm foot platform and Linnehan becomes the free floater. Linnehan translates to the ASIPE, retrieves the PFR from temporary stowage and transfers it to Grunsfeld, who installs it in foot restraint receptacle 19 in preparation for spacewalk two. Linnehan retrieves the Bay 10 Thermal



## STS-109

---

Cover and installs it over Bay 10 of the Telescope while Grunsfeld disengages and removes the telescope's +V2 trunnion EPS panel, mates the DBC cross strap harness and installs a MLI tent over the EPS panel cavity.

For the daily closeout, Linnehan inspects the FSS main umbilical mechanism, disengages the two center PIP pins on the BSP, retracts the mini-TA, retracts the port and starboard TAs if required, and takes a tool inventory. Meanwhile, Grunsfeld prepares the CATs installed on the MFR handrail for return into the airlock and egresses the MFR. Linnehan releases the MFR safety tether from the grapple fixture for contingency Earth return. With that complete, the astronauts return to the airlock and Columbia's cabin.

### **Spacewalk Number Two, Flight Day Five: Replace +V2 Solar Array and Diode Box Assembly and Reaction Wheel Assembly-1**

For spacewalk two, Newman will be free floating and Massimino will work from the arm foot platform. The major objectives are to replace the +V2 Solar Array, the array oriented toward Columbia's port side, and the Diode Box Assembly on the telescope and complete the DBC installation by mating it to the +V2 SA3. They also will replace the Reaction Wheel Assembly – 1 (RWA-1).

Fewer daily setup tasks are required for spacewalk two than for spacewalk one. After completing the airlock egress procedure, Newman reconnects the safety strap on the MFR, installs the two BSP center PIP pins and deploys the mini-TA. Massimino exits the airlock with the spacewalk two required CATs installed on the MFR handrail and installs the MFR handrail.

After completing the daily setup tasks, the astronauts begin the tasks for the +V2 Solar Array and Diode Box Assembly change-outs, which are similar to the -V2 Solar Array and Diode Box Assembly change-outs performed during the first spacewalk. First, Newman and Massimino retrieve the HST PFR and APE and install them on HST foot restraint receptacle 19. Newman translates to the RAC to retrieve a Portable Connector Tray and temporarily stows it on the telescope. Then he ingresses the PFR. Together the astronauts retract the +V2 SA2 PDM. Newman then engages the PDM lock and installs the Portable Connector Tray. Still in the PFR, Newman demates the SA2 connectors from the DBA while Massimino disengages five of six bolts on each door of HST Bays 2, 3 and 4 in support of the PCU change-out during the third spacewalk.

Next, the astronauts remove the +V2 SA2 from the telescope. They disengage the SADA Clamp, remove SA2, translate it to the RAC and install it on the port shelf via the SADA Clamp and forward constraint PIP pin mechanical attachments. Newman translates back to the telescope and removes the +V2 DBA by disengaging the remaining X-connector drive mechanism and releasing the four J-hook bolts while Massimino retrieves the DBA2 from the RAC and translates it to Newman at the telescope worksite. The astronauts swap hardware and Newman installs the DBA2 on the telescope while Massimino translates to the RAC with the DBA and installs it and closes its thermal cover.

## STS-109

---

With the +V2 DBA2 now installed on the telescope, they begin installation work for the replacement Solar Array (SA3). Both astronauts translate to the RAC. Massimino disengages Latch 5, deploys the mast, and engages the two mast bolts. Newman ingresses the forward PFR, releases and pivots Latch 3 to clear the tang, disengages the two tang bolts, stows the tang and engages the two tang bolts. Massimino disengages Latch 2. Newman pivots Latch 3 to the stowed position and installs the PIP pin, deploys the MLI flap over the tang interface and releases Latch 4. Newman stabilizes SA3 while Massimino releases Latch 1. Both remove SA3 from the RAC.

Working together, the astronauts install SA3 onto the telescope by properly orienting SA3 and inserting the SADA into the SADA Clamp until the three soft dock tangs engage. Newman engages the SADA Clamp closed and mates the SA3 electrical interfaces, then mates the DBC cross-strap harness to the +V2 DBA2. Massimino translates back to the RAC and performs the SA2 closeout work: engaging the aft latch, the forward latch and the two forward constraint bolts.

Both astronauts work together again to deploy the SA3 panel, engage the panel locking bolts and release the SA3 brake. Newman removes the HST PFR and APE and stows them on the FSS, and removes and stows the Portable Connector Tray on the RAC. Upon completion of the SA changeout task, the spacewalkers will replace the RWA-1. Newman translates to the Large Orbital Replacement Unit Protective Enclosure (LOPE) on the aft starboard side of the Multi-Use Lightweight Equipment (MULE), opens the lid, removes the two RWA1-R wing tab connectors from the LOPE pouch and secures them to the RWA1-R handle Velcro, disengages the three keyway bolts, removes the replacement RWA-1 (RWA1-R), and translates to the top of the starboard MULE.

Massimino maneuvers to Bay 6 and opens the Bay 6 door, demates the two RWA-1 wing tab heater connectors from the heater bracket, demates the two RWA-1 wing tab connectors from RWA-1, disengages the three RWA-1 keyway bolts, and removes RWA-1 from HST Bay 6. Then he maneuvers to the starboard MULE location and performs a RWA swap with Newman. Massimino then maneuvers with RWA1-R to the Bay 6 worksite, installs it on HST, engages the three keyway bolts, and mates the four wing tab electrical connectors. Then he closes the Bay 6 door.

Newman, after transferring the RWA1-R to Massimino and receiving RWA-1, translates back to the LOPE, installs the RWA-1 in the LOPE, engages the three keyway bolts, stows the two wing tab connectors in the LOPE pouch, and closes the LOPE lid.

Newman retrieves the Bay 5 Thermal Cover and installs it in the retracted position on the HST Bay 5 in preparation for the PCU change-out on spacewalk three. Newman also retrieves the doorstep extensions and installs them on the +V2 aft shroud doorstops in preparation for the NCS Radiator installation on spacewalk five.

For the daily closeout, Newman inspects the FSS main umbilical mechanism, disengages the two center PIP pins on the BSP, retracts the mini-TA, retracts the port and starboard TAs if required and takes a tool inventory. Meanwhile, Massimino prepares the CATs installed on the MFR handrail for return into the airlock and egresses the MFR. Newman

## STS-109

---

releases the MFR safety tether from the grapple fixture for contingency Earth return. Then the astronauts return to the airlock and Columbia's cabin.

### **Spacewalk Number Three, Flight Day Six: Replace Power Control Unit (PCU)**

During the third spacewalk, Grunsfeld and Linnehan will replace the PCU in HST Bay 4. They begin the spacewalk with Grunsfeld free floating and Linnehan working from the arm foot platform but switch places after about three hours. The third spacewalk is planned to last about seven hours.

After they exit the airlock, Grunsfeld reconnects the safety strap on the MFR, installs the two BSP center PIP pins and deploys the mini-TA. Linnehan exits the airlock with the spacewalk three required CATs installed on the MFR handrail and installs the MFR handrail.

Both astronauts complete the daily setup tasks, and then begin the PCU change-out. Grunsfeld translates to the RAC to retrieve the Power Distribution Unit (PDU) fuse plug caddy and battery stringers and transfers them to Linnehan. Linnehan translates to HST Bay 3, opens the bay door, demates the three battery connectors, installs caps to deadface the battery power and temporarily closes the door. He then translates to Bay 2 and performs the same procedure for the Bay 2 battery.

Meanwhile, Grunsfeld translates to Bay 5 and deploys the thermal cover, retrieves the DBA thermal cover, translates to the +V2 DBA2 and installs its thermal cover. Then he translates to Bay 10 and deploys the thermal cover, retrieves the DBA thermal cover, translates to the -V2 DBA2 and installs its thermal cover. Grunsfeld deploys the FHST covers on the telescope, then translates to the SAC, retrieves the Harness Retention Device and transfers it to Linnehan at the Bay 4 worksite.

Linnehan opens the Bay 4 door and installs the Harness Retention Device and door stay. Linnehan then removes the six in-board PDU Fuse Plugs to gain sufficient access to the PCU connectors on the left side. Grunsfeld retrieves the PCU handhold from the SAC and temporarily stows it by the +V2 trunnion. Then he translates to the airlock and recharges his suit with oxygen, enabling him to extend his EVA time. Linnehan disengages seven of 10 PCU keyway bolts and demates all but the last six connectors.

At this point, Grunsfeld and Linnehan switch places: Grunsfeld begins work from the arm foot platform and Linnehan works free-floating for the remainder of the spacewalk. Grunsfeld completes demating the remaining PCU connectors, installs the PCU handhold, disengages the three remaining bolts, disengages the PCU ground strap and removes the PCU from the telescope.

Linnehan translates to the starboard SAC where the replacement PCU (PCU-R) is located, ingresses the PFR, opens the thermal cover, disengages the six keyway bolts and removes the PCU-R from the SAC. Linnehan and Grunsfeld swap boxes at the SAC worksite. Grunsfeld translates with the PCU-R back to the telescope worksite, installs it, engages seven keyway bolts and engages the ground strap. Linnehan stows the PCU on the SAC,

## STS-109

---

engages the six keyway bolts, retightens the two PCU handhold wing bolts, egresses the PFR and reinstalls the PCU thermal cover. He then translates to the airlock and recharges his suit with oxygen. Grunsfeld mates the 36 connectors on the PCU-R, a difficult and time-consuming task.

Linnehan inspects the HST exterior handrails to be used for the ACS and NCS tasks on the fourth and fifth spacewalks, and, if required, installs handrail covers. Grunsfeld reinstalls the PDU fuse plugs, removes the Harness Retention Device, removes the door stay, and closes the HST Bay 4 door with one J-bolt. He re-opens the Bay 3 door, remates the battery connectors and closes the door with one J-bolt. Then he performs the same procedure for the Bay 2 battery. After the PDU fuse plugs are reinstalled, Linnehan translates to the +V2 DBA2, retrieves the thermal cover, stows it on its Bay 5 thermal cover stowage pouch and retracts the Bay 5 thermal cover. He translates to the -V2 DBA2, retrieves the thermal cover, stows it on its Bay 10 thermal cover stowage pouch and retracts the Bay 10 thermal cover. Next, Linnehan retrieves the Harness Retention Device and stows it on the SAC. Then, he retracts the FHST covers, receives the PDU fuse plug caddy and battery stringers from Grunsfeld, and stows them on the RAC. If time allows, Grunsfeld removes the WFPC thermal cover and stows it on the SAC.

For the daily closeout, Linnehan inspects the FSS main umbilical mechanism, disengages the two center PIP pins on the BSP, retracts the mini-TA, retracts the port and starboard TAs if required and takes a tool inventory. Meanwhile, Grunsfeld prepares the CATs installed on the MFR handrail for return into the airlock and egresses the MFR. Linnehan releases the MFR safety tether from the grapple fixture for contingency Earth return. Then the astronauts return to the airlock, completing the third spacewalk.

### **Spacewalk Number Four, Flight Day Seven: Replace Faint Object Camera with the Advanced Camera for Surveys, Install Electronics Support Module and Perform Power Control Unit Cleanup Tasks**

On the fourth spacewalk, Newman begins work in the arm foot platform and Massimino works free-floating. The two spacewalkers switch work locations about halfway through the planned 6 ½ -hour spacewalk. The major objectives are to replace the Faint Object Camera (FOC) with the new Advanced Camera for Surveys (ACS), an instrument with 10 times the discovery power; install an Electronics Support Module (ESM), part of NICMOS cryocooler installation the next day, in the telescope's aft shroud; and do the remaining PCU cleanup tasks. After exiting the airlock, Massimino reconnects the safety strap on the MFR, installs the two BSP center PIP pins and deploys the mini-TA. Newman exits the airlock with the spacewalk four required CATs installed on the MFR handrail and installs the MFR handrail.



### ***Electronic Support Module (ESM).***

The astronauts complete the daily setup tasks, and then begin the FOC/ACS change-out. Massimino deploys the aft fixture, retrieves the COSTAR Y-harness from the RAC port ATM and stows it on the telescope aft shroud. Newman opens the -V2 aft shroud doors. Massimino and Newman work together to remove the FOC from HST. Massimino demates the four FOC connectors, disconnects the FOC purge line and disconnects the ground strap. Newman disengages the FOC A-Latch and Massimino disengages the FOC B-Latch. Then Newman removes the FOC from the telescope and stows it on the aft fixture.

Massimino and Newman now work together to install the Cross Aft Shroud Harness (CASH). Even though the CASH is part of the NCS installation, it is installed now for maximum efficiency. Its early installation eliminates the need to open the -V2 aft shroud doors a second time during the fifth spacewalk. Massimino and Newman retrieve the CASH from the SAC and install it on handrails inside the aft shroud.

Massimino and Newman retrieve the ACS from the ASIPE. Massimino configures the aft ASIPE PFR, opens the ASIPE lid, disconnects the ACS ground strap and deploys the B-Latch alignment aid. Newman disengages the A-Latch and Massimino disengages the B-Latch. They both remove the ACS from the ASIPE. Massimino closes the ASIPE lid and engages one lid latch to maintain thermal stability inside the ASIPE. The astronauts continue to work together to install the ACS into the telescope aft shroud. They insert the ACS along the guide rails, deploy the B-Latch alignment aid arm, engage the B-Latch and A-Latch, stow the alignment aid, tether the ESM ground strap to the ACS handrail, reinstall the HST ground strap and mate the four ACS connectors.

## STS-109

---

Next the astronauts install the FOC into the ASIPE. Newman retrieves the FOC from the aft fixture while Massimino re-opens the ASIPE lid. Newman inserts the FOC into the ASIPE guide rails while Massimino stows the aft fixture and engages the FOC B-Latch. Newman engages the A-Latch. Massimino disengages the FOC ground strap bolt and installs the ground strap on FOC, then closes the ASIPE lid and engages the five lid latches.

After completing the FOC installation into the ASIPE, the astronauts switch work locations, with Massimino climbing into the arm foot platform and Newman becoming the free-floating spacewalkers. Then they retrieve the ESM from the MULE and install it in the -V2 aft shroud. They install the ACS ESM ground strap on the ESM, retrieve the Y-harness from temporary stowage, demate the four COSTAR connectors, mate four Y-harness connectors to the COSTAR harnesses, mate four Y-harness connectors to COSTAR and mate four Y-harness connectors to the ESM. Massimino mates the four CASH connectors to the ESM. Now they are ready to close the -V2 aft shroud doors.

The PCU cleanup task follows the FOC/ACS change-out and the ESM installation. Newman removes the Bay 10 thermal cover and stows it on the ASIPE, then removes the Bay 5 thermal cover and stows it on the ASIPE. He also articulates the aft ASIPE PFR to its landing configuration. Meanwhile, Massimino engages the remaining 5 J-bolts on each door of Bays 2, 3 and 4. Then the astronauts remove the FHST and WFPC covers from the telescope and stow them on the SAC.

For the daily closeout, Newman inspects the FSS main umbilical mechanism, disengages the two center PIP pins on the BSP, retracts the mini-TA, retracts the port and starboard TAs if required and takes a tool inventory. Meanwhile, Massimino prepares the CATs installed on the MFR handrail for return into the airlock and egresses the MFR. Newman releases the MFR safety tether from the grapple fixture for contingency Earth return. Then they reenter the airlock and Columbia, completing the spacewalk.

### **Spacewalk Number Five, Flight Day Eight: Install the Near-Infrared Camera and Multi-Object Spectrometer (NICMOS) Cryogenic Cooler and NICMOS Cooling System Radiator**

During the fifth spacewalk, Grunsfeld will begin work from the arm platform and Linnehan will work free-floating. They will switch locations halfway through the seven-hour spacewalk. The major objectives are to install the NICMOS Cooling System, a NICMOS Cryogenic Cooler (NCC) and NICMOS Cooling System (NCS) Radiator. After they exit the airlock, Linnehan reconnects the safety strap on the MFR, installs the two BSP center PIP pins, and deploys the mini-TA. Grunsfeld exits the airlock with the spacewalk five CATs installed on the MFR handrail and installs the MFR handrail.

Both astronauts complete the daily setup tasks, and then begin the NCS installation. Grunsfeld opens the telescope's +V2 aft shroud doors while Linnehan retrieves the Cryo Vent Line (CVL) bag and NCS sock bag from the RAC port ATM and the NCC ground strap and cryo vent insert from the RAC starboard ATM. Together the astronauts prepare the NICMOS for the NCS installation. They remove the NICMOS CVL and stow it in the CVL bag, close the NICMOS vent line valve, disengage the NICMOS ground strap from NICMOS, install the NCC ground strap adapter on NICMOS and install the cryo vent insert.

## STS-109

---

Linnehan retrieves the P600 harness from the RAC starboard ATM. Grunsfeld retrieves the NCC from the SAC and opens the neon bypass valve while Linnehan closes the NCC contamination cover.

Both astronauts install the NCC into the HST aft shroud. Grunsfeld installs the NCC ground strap on NCC and mates the four CASH connectors. Linnehan translates to the MULE and releases some of the NCS Radiator latches and shear ties. At this point, they switch locations, with Linnehan working from the arm foot platform and Grunsfeld free-floating for the remainder of the spacewalk.

Next comes retrieval of the NCS Radiator. Grunsfeld closes the left aft shroud door and together with Linnehan disengages the remaining latches, removes the NCS Radiator from the MULE and opens the NCS Radiator handrail latches. They install the NCS Radiator onto the exterior of the telescope aft shroud.

Grunsfeld prepares the NCC by installing the coolant-in and coolant-out cryo valve heaters and neon lines while Linnehan installs the NCC power cable to the EPS test panel and reinstalls the MLI tent. They install the NCS Radiator conduit through the cryo vent insert opening in the aft bulkhead and engage the cryo vent insert latches and locking bolts. Then the NCS Radiator harnesses are mated to the NCS, the NCC saddle thermal cover opened and the CPL evaporator removed from the sock and tethered to the bulkhead standoff by Grunsfeld. Linnehan opens the NCS Radiator diode box, checks some LEDs and switches, and closes the diode box cover. He installs the CPL evaporator in the saddle, installs the saddle cover, engages its two bolts and closes the NCC saddle thermal cover. Together the astronauts close the aft shroud doors.

The final closeout procedure follows the NCS installation. Grunsfeld inspects the FSS main umbilical mechanism and the P105/P106 covers, removes the LGA protective cover from the telescope and reinstalls it on the FSS, disengages the two center PIP pins on the BSP, retracts the mini-TA, retracts the port and starboard TAs, if required, to their landing configurations and takes a tool inventory. Meanwhile, Linnehan prepares the CATs installed on the MFR handrail for return into the airlock, egresses the MFR and performs the MFR stow procedure. That completes the fifth spacewalk.

## EVA Timeline Overview

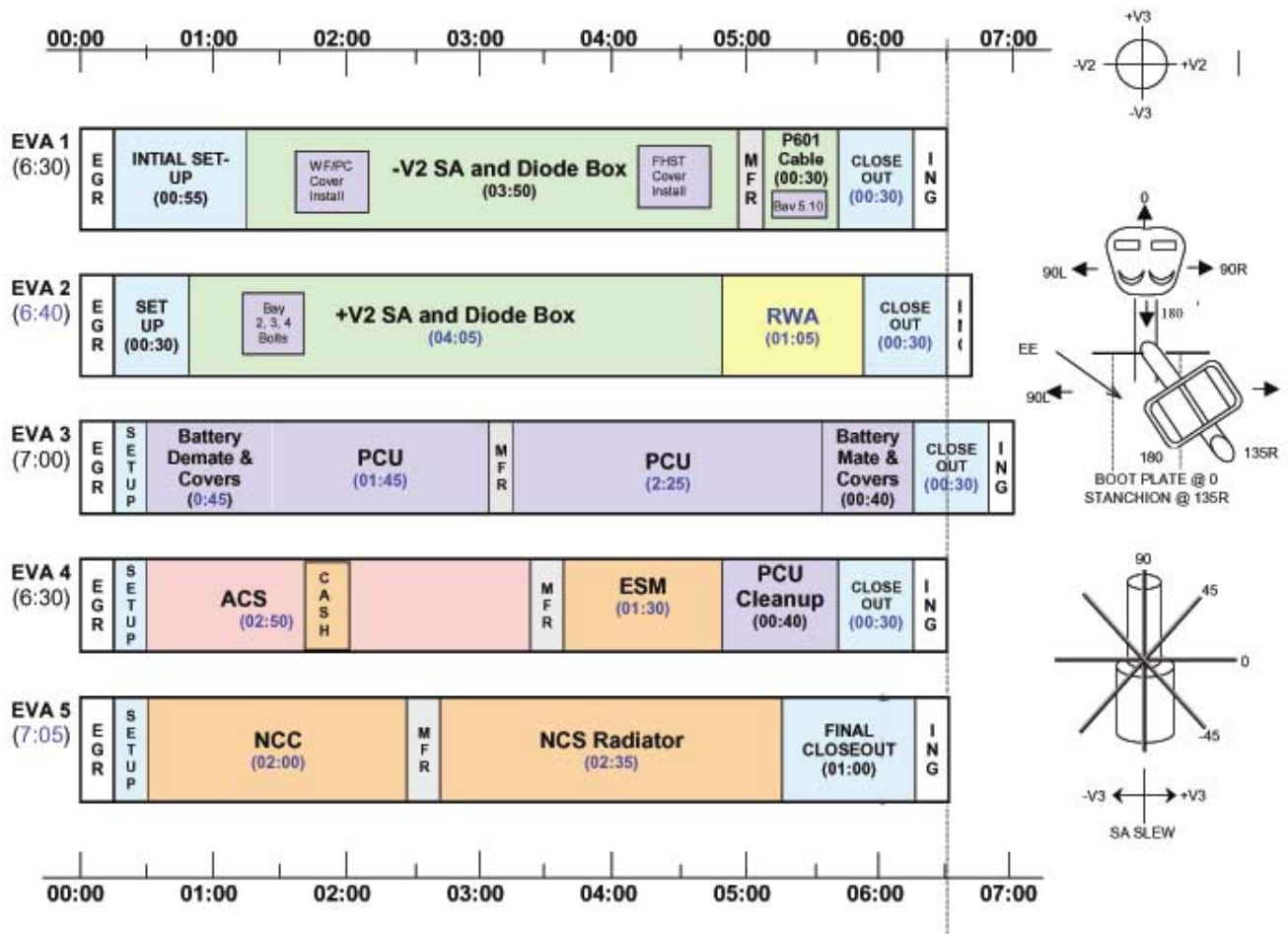



## Experiments

### DTOs and DSOs

Detailed Test Objectives (DTOs) are aimed at testing, evaluating or documenting space shuttle systems or hardware, or proposed improvements to space shuttle hardware, systems and operations.

Detailed Supplementary Objectives (DSOs) are space and life science investigations. Their purpose is to determine the extent of physiological deconditioning resulting from space flight, to test countermeasures to those changes and to characterize the environment of the space shuttle relative to crew health.

The following such experiments are aboard Columbia:

#### **DTO 700-14**

##### **Single-String Global Positioning System**

The purpose of the Single-String Global Positioning System (GPS) is to demonstrate the performance and operation of the GPS during orbiter ascent, on-orbit, entry and landing phases. It uses a modified military GPS receiver processor and the existing orbiter GPS antennas. GPS data may be downlinked during all mission phases. This is the 21st flight of DTO 700-14.

#### **DTO 805**

##### **Crosswind Landing Performance**

DTO 805 will demonstrate the capability to perform a manually controlled landing in the presence of a crosswind. The testing is done in two steps:

1. **Prelaunch:** Ensure planning will allow selection of a runway with Microwave Scanning Beam Landing System support, which is a set of dual transmitters located beside the runway providing precision navigation vertically, horizontally and longitudinally with respect to the runway. This precision navigation subsystem helps provide a higher probability of a more precise landing with a crosswind of 10 to 15 knots as late in the flight as possible.
2. **Entry:** This test requires that the crew perform a manually controlled landing in the presence of a 90-degree crosswind component of 10 to 15 knots steady state. During a crosswind landing, the drag chute will be deployed after nose gear touchdown when the vehicle is stable and tracking the runway centerline. This DTO has been manifested on 68 previous flights.

## **DSO 490**

### **Bioavailability and Performance Effects of Promethazine During Space Flight**

Promethazine (PMZ) is the anti-motion sickness medication of choice for treating space motion sickness during shuttle missions. Usual side effects include dizziness, drowsiness, sedation and impaired psychomotor performance, which could impact crew performance of mission operations. Early reports from crewmembers indicate that these central nervous system side effects of PMZ are absent or greatly reduced in microgravity. Tests on Columbia will test PMZ's performance, side effects, and efficacy in microgravity. On-orbit tests will evaluate responses to various doses and effectiveness of intramuscular, oral and suppository methods of administration. Results will then be compared with preflight evaluations. This is the second flight of DSO 490.

## **DSO 493**

### **Monitoring Latent Virus Reactivation and Shedding in Astronauts**

The premise of this DSO is that the incidence and duration of latent virus reactivation in saliva and urine can increase during space flight. The objective is to determine the frequency of reactivation of latent viruses, latent virus shedding and clinical disease after exposure to the physical, physiological and psychological stressors associated with space flight. Induced-induced alterations in the immune response become increasingly important on long missions, particularly the potential for reactivation and dissemination (shedding) of latent viruses. An example of a latent virus is Herpes Simplex Type 1 (HSV-1), which infects 70 to 80 percent of all adults. Its classic manifestations are cold sores, pharyngitis and tonsillitis. It usually is acquired through contact with the saliva, skin or mucous membranes of an infected individual. However, many recurrences are asymptomatic, resulting in shedding of the virus.

## **DSO 496**

### **Individual Susceptibility to Post-Space Flight Orthostatic Intolerance**

Susceptibility to postflight orthostatic intolerance—lightheadedness or fainting upon return to Earth—is highly individual. Some astronauts are little affected, while others have severe symptoms. Women are more often affected than men. This DSO will study the mechanisms responsible for these differences to customize countermeasure protocols. It has been well documented that space flight significantly alters cardiovascular function. One of the most important changes from a crew safety standpoint is postflight loss of orthostatic tolerance, which causes astronauts to have difficulty walking independently and induces lightheadedness or fainting. These effects may impair their ability to leave the orbiter after it lands. This DSO will study preflight and postflight differences in susceptible and nonsusceptible astronauts. There are no on-orbit activities associated with this DSO.

## **DSO 498**

### **Space Flight and Immune Function**

Astronauts face an increasing risk of contracting infectious diseases as they work and live for longer periods in the crowded conditions and closed environments of spacecraft such as the International Space Station. The effects of space flight on the human immune system, which plays a pivotal role in warding off infections, is not fully understood. Understanding the changes in immune functions caused by exposure to microgravity will allow researchers to develop countermeasures to minimize the risk of infection. DSO 498 will look at the effects of space flight on neutrophils, monocytes and cytotoxic cells, which play an important role in maintaining an effective defense against infectious agents. Scientists believe that space changes the way these cells function. Researchers will analyze neutrophils and monocytes from astronaut blood samples taken before and after the flight. They will also assess the subjects' pre- and postflight production of cytotoxic cells and cytokine. This study will complement previous and continuing immunology studies of astronauts' adaptation to space.

## **DSO 500**

### **Induced-Induced Reactivation of Latent Epstein-Barr Virus**

The effects of microgravity, along with associated physical and psychological stress, decrease Epstein-Barr virus (EBV)-specific T-cell immunity and reactivate latent EBV in infected B-lymphocytes. DSO 500 will examine the mechanisms of induced-induced alterations in human immune function and latent virus reactivation. Specifically, it will determine the magnitude of immunosuppression as a result of space flight by analyzing stress hormones, performing quantitative analysis of EBV replication using molecular and serological methods, and determining virus-specific T-cell immune function. This is the second flight of DSO 500.

## **DSO 503S**

### **Test of Midodrine as a Countermeasure Against Postflight Orthostatic Hypotension**

After space flight, astronauts returning to upright posture may experience the inability to maintain adequate arterial pressure and cerebral perfusion (orthostatic or postural hypotension). This may result in lightheadedness or loss of consciousness during reentry or egress. DSO 503S will evaluate the efficacy of midodrine, a medicine commonly used to treat low blood pressure. It works by stimulating nerve endings in blood vessels, causing the blood vessels to tighten, which increases blood pressure. The experiment will assess midodrine's effectiveness in reducing the incidence and/or severity of orthostatic hypotension in returning astronauts. This is the second flight of DSO 503S.

## **DSO 634**

### **Sleep–Wake Actigraphy and Light Exposure During Space Flight**

Disruption of sleep during space flight, both short and long duration, is associated with inappropriately timed (non-24 hour) or insufficiently intense light exposure. Sleep disruption and circadian misalignment can lead to unsatisfactory sleep quality and daytime alertness, which could impair mission success. This experiment will monitor sleep–wake activity and light exposure patterns obtained in flight. These data should help better understand the effects of space flight on sleep, as well as aid in the development of effective countermeasures for both short- and long-duration space flight.

## **DSO 635**

### **Spatial Reorientation Following Space Flight**

Spatial orientation is altered during and after space flight by a shift of central vestibular processing (from a gravitational frame of reference to an internal, head-centered frame of reference) that occurs during adaptation to microgravity and is reversed during the first few days after return to Earth. During the postflight re-adaptive period, discordant sensory stimuli can temporarily disorient a subject by triggering a shift (state change) to the previously learned, internally referenced, microgravity-adapted pattern of spatial orientation and sensorimotor control. This DSO will examine both the adaptive changes in the spatial reference frame used for coding spatial orientation and sensorimotor control, as well as the fragility of the adaptive process and the feasibility of driving state changes in central vestibular processing via discordant sensory stimuli using balance control tests and eye movement responses to pitch-axis rotation in a short-arm centrifuge. The findings are expected to demonstrate the degree to which challenging motion environments may affect postflight re-adaptation and lead to a better understanding of safe postflight activity regimens.

## **DSO 802**

### **Educational Activities**

This DSO will provide live TV downlink of the mission to classrooms in hopes of attracting students to careers in science, engineering and mathematics. The addition of this DSO to a particular flight is coordinated through the JSC Educational Working Group. The tasks required by this DSO support three distinct objectives: 1) Produce educational products, such as 20-minute video lessons, with scenes of educational activities performed by the flight crew recorded both in space and on the ground. 2) Support the live TV downlink of educational activities performed by the flight crew explicitly for, or involving participation by, students and teachers. 3) Support the live or videotaped TV downlink of educational activities performed by the flight crew for a general audience.

## Shuttle Reference Data

### Shuttle Abort History

#### **RSLs Abort History:**

##### **(STS-41 D) June 26, 1984**

The countdown for the second launch attempt for Discovery's maiden flight ended at T-4 seconds when the orbiter's computers detected a sluggish valve in main engine #3. The main engine was replaced and Discovery was finally launched on August 30, 1984.

##### **(STS-51 F) July 12, 1985**

The countdown for Challenger's launch was halted at T-3 seconds when on-board computers detected a problem with a coolant valve on main engine #2. The valve was replaced and Challenger was launched on July 29, 1985.

##### **(STS-55) March 22, 1993**

The countdown for Columbia's launch was halted by on-board computers at T-3 seconds following a problem with purge pressure readings in the oxidizer preburner on main engine #2. Columbia's three main engines were replaced on the launch pad, and the flight was rescheduled behind Discovery's launch on STS-56. Columbia finally launched on April 26, 1993.

##### **(STS-51) August 12, 1993**

The countdown for Discovery's third launch attempt ended at the T-3 second mark when on-board computers detected the failure of one of four sensors in main engine #2 which monitor the flow of hydrogen fuel to the engine. All of Discovery's main engines were ordered replaced on the launch pad, delaying the Shuttle's fourth launch attempt until September 12, 1993.

##### **(STS-68) August 18, 1994**

The countdown for Endeavour's first launch attempt ended 1.9 seconds before liftoff when on-board computers detected higher than acceptable readings in one channel of a sensor monitoring the discharge temperature of the high pressure oxidizer turbopump in main engine #3. A test firing of the engine at the Stennis Space Center in Mississippi on September 2nd confirmed that a slight drift in a fuel flow meter in the engine caused a slight increase in the turbopump's temperature. The test firing also confirmed a slightly slower start for main engine #3 during the pad abort, which could have contributed to the higher temperatures. After Endeavour was brought back to the Vehicle Assembly Building to be outfitted with three replacement engines, NASA managers set October 2nd as the date for Endeavour's second launch attempt.

# STS-109

---

## **Abort to Orbit History:**

### **(STS-51 F) July 29, 1985**

After an RSLS abort on July 12, 1985, Challenger was launched on July 29, 1985. Five minutes and 45 seconds after launch, a sensor problem resulted in the shutdown of center engine #1, resulting in a safe "abort to orbit" and successful completion of the mission.

Updated: 05/22/2001

## Shuttle Reference Data

### Shuttle Abort Modes

#### RSLs ABORTS

These occur when the onboard shuttle computers detect a problem and command a halt in the launch sequence after taking over from the Ground Launch Sequencer and before Solid Rocket Booster ignition.

#### ASCENT ABORTS

Selection of an ascent abort mode may become necessary if there is a failure that affects vehicle performance, such as the failure of a space shuttle main engine or an orbital maneuvering system. Other failures requiring early termination of a flight, such as a cabin leak, might also require the selection of an abort mode.

There are two basic types of ascent abort modes for space shuttle missions: intact aborts and contingency aborts. Intact aborts are designed to provide a safe return of the orbiter to a planned landing site. Contingency aborts are designed to permit flight crew survival following more severe failures when an intact abort is not possible. A contingency abort would generally result in a ditch operation.

#### INTACT ABORTS

There are four types of intact aborts: abort to orbit (ATO), abort once around (AOA), transoceanic abort landing (TAL) and return to launch site (RTLs).

#### Return to Launch Site

The RTLs abort mode is designed to allow the return of the orbiter, crew, and payload to the launch site, Kennedy Space Center, approximately 25 minutes after lift-off.

The RTLs profile is designed to accommodate the loss of thrust from one space shuttle main engine between lift-off and approximately four minutes 20 seconds, at which time not enough main propulsion system propellant remains to return to the launch site.

An RTLs can be considered to consist of three stages--a powered stage, during which the space shuttle main engines are still thrusting; an ET separation phase; and the glide phase, during which the orbiter glides to a landing at the Kennedy Space Center. The powered RTLs phase begins with the crew selection of the RTLs abort, which is done after solid rocket booster separation. The crew selects the abort mode by positioning the abort rotary switch to RTLs and depressing the abort push button. The time at which the RTLs is selected depends on the reason for the abort. For example, a three-engine RTLs is selected at the last moment, approximately three minutes 34 seconds into the mission; whereas an RTLs chosen due to an engine out at lift-off is selected at the earliest time, approximately two minutes 20 seconds into the mission (after solid rocket booster separation).

# STS-109

---

After RTLS is selected, the vehicle continues downrange to dissipate excess main propulsion system propellant. The goal is to leave only enough main propulsion system propellant to be able to turn the vehicle around, fly back towards the Kennedy Space Center and achieve the proper main engine cutoff conditions so the vehicle can glide to the Kennedy Space Center after external tank separation. During the downrange phase, a pitch-around maneuver is initiated (the time depends in part on the time of a space shuttle main engine failure) to orient the orbiter/external tank configuration to a heads up attitude, pointing toward the launch site. At this time, the vehicle is still moving away from the launch site, but the space shuttle main engines are now thrusting to null the downrange velocity. In addition, excess orbital maneuvering system and reaction control system propellants are dumped by continuous orbital maneuvering system and reaction control system engine thrustings to improve the orbiter weight and center of gravity for the glide phase and landing.

The vehicle will reach the desired main engine cutoff point with less than 2 percent excess propellant remaining in the external tank. At main engine cutoff minus 20 seconds, a pitch-down maneuver (called powered pitch-down) takes the mated vehicle to the required external tank separation attitude and pitch rate. After main engine cutoff has been commanded, the external tank separation sequence begins, including a reaction control system translation that ensures that the orbiter does not recontact the external tank and that the orbiter has achieved the necessary pitch attitude to begin the glide phase of the RTLS.

After the reaction control system translation maneuver has been completed, the glide phase of the RTLS begins. From then on, the RTLS is handled similarly to a normal entry.

## **Transoceanic Abort Landing**

The TAL abort mode was developed to improve the options available when a space shuttle main engine fails after the last RTLS opportunity but before the first time that an AOA can be accomplished with only two space shuttle main engines or when a major orbiter system failure, for example, a large cabin pressure leak or cooling system failure, occurs after the last RTLS opportunity, making it imperative to land as quickly as possible.

In a TAL abort, the vehicle continues on a ballistic trajectory across the Atlantic Ocean to land at a predetermined runway. Landing occurs approximately 45 minutes after launch. The landing site is selected near the nominal ascent ground track of the orbiter in order to make the most efficient use of space shuttle main engine propellant. The landing site also must have the necessary runway length, weather conditions and U.S. State Department approval. Currently, the three landing sites that have been identified for a due east launch are Moron, Spain; Dakar, Senegal; and Ben Guerur, Morocco (on the west coast of Africa).

To select the TAL abort mode, the crew must place the abort rotary switch in the TAL/AOA position and depress the abort push button before main engine cutoff. (Depressing it after main engine cutoff selects the AOA abort mode.) The TAL abort mode begins sending commands to steer the vehicle toward the plane of the landing site. It also rolls the vehicle heads up before main engine cutoff and sends commands to begin an orbital maneuvering system propellant dump (by burning the propellants through the orbital maneuvering



# STS-109

---

system engines and the reaction control system engines). This dump is necessary to increase vehicle performance (by decreasing weight), to place the center of gravity in the proper place for vehicle control, and to decrease the vehicle's landing weight.

TAL is handled like a nominal entry.

## **Abort to Orbit**

An ATO is an abort mode used to boost the orbiter to a safe orbital altitude when performance has been lost and it is impossible to reach the planned orbital altitude. If a space shuttle main engine fails in a region that results in a main engine cutoff under speed, the Mission Control Center will determine that an abort mode is necessary and will inform the crew. The orbital maneuvering system engines would be used to place the orbiter in a circular orbit.

## **Abort Once Around**

The AOA abort mode is used in cases in which vehicle performance has been lost to such an extent that either it is impossible to achieve a viable orbit or not enough orbital maneuvering system propellant is available to accomplish the orbital maneuvering system thrusting maneuver to place the orbiter on orbit and the deorbit thrusting maneuver. In addition, an AOA is used in cases in which a major systems problem (cabin leak, loss of cooling) makes it necessary to land quickly. In the AOA abort mode, one orbital maneuvering system thrusting sequence is made to adjust the post-main engine cutoff orbit so a second orbital maneuvering system thrusting sequence will result in the vehicle deorbiting and landing at the AOA landing site (White Sands, N.M.; Edwards Air Force Base; or the Kennedy Space Center). Thus, an AOA results in the orbiter circling the Earth once and landing approximately 90 minutes after lift-off.

After the deorbit thrusting sequence has been executed, the flight crew flies to a landing at the planned site much as it would for a nominal entry.

## **CONTINGENCY ABORTS**

Contingency aborts are caused by loss of more than one main engine or failures in other systems. Loss of one main engine while another is stuck at a low thrust setting may also necessitate a contingency abort. Such an abort would maintain orbiter integrity for in-flight crew escape if a landing cannot be achieved at a suitable landing field.

Contingency aborts due to system failures other than those involving the main engines would normally result in an intact recovery of vehicle and crew. Loss of more than one main engine may, depending on engine failure times, result in a safe runway landing. However, in most three-engine-out cases during ascent, the orbiter would have to be ditched. The in-flight crew escape system would be used before ditching the orbiter.

# STS-109

---

## **ABORT DECISIONS**

There is a definite order of preference for the various abort modes. The type of failure and the time of the failure determine which type of abort is selected. In cases where performance loss is the only factor, the preferred modes would be ATO, AOA, TAL and RTLS, in that order. The mode chosen is the highest one that can be completed with the remaining vehicle performance.

In the case of some support system failures, such as cabin leaks or vehicle cooling problems, the preferred mode might be the one that will end the mission most quickly. In these cases, TAL or RTLS might be preferable to AOA or ATO. A contingency abort is never chosen if another abort option exists.

The Mission Control Center-Houston is prime for calling these aborts because it has a more precise knowledge of the orbiter's position than the crew can obtain from onboard systems. Before main engine cutoff, Mission Control makes periodic calls to the crew to tell them which abort mode is (or is not) available. If ground communications are lost, the flight crew has onboard methods, such as cue cards, dedicated displays and display information, to determine the current abort region.

Which abort mode is selected depends on the cause and timing of the failure causing the abort and which mode is safest or improves mission success. If the problem is a space shuttle main engine failure, the flight crew and Mission Control Center select the best option available at the time a space shuttle main engine fails.

If the problem is a system failure that jeopardizes the vehicle, the fastest abort mode that results in the earliest vehicle landing is chosen. RTLS and TAL are the quickest options (35 minutes), whereas an AOA requires approximately 90 minutes. Which of these is selected depends on the time of the failure with three good space shuttle main engines.

The flight crew selects the abort mode by positioning an abort mode switch and depressing an abort push button.

Updated: 05/22/2001

## Shuttle Reference Data

### Space Shuttle Rendezvous Maneuvers

#### COMMON SHUTTLE RENDEZVOUS MANEUVERS

**OMS-1 (Orbit insertion)** - Rarely used ascent abort burn

**OMS-2 (Orbit insertion)** - Typically used to circularize the initial orbit following ascent, completing orbital insertion. For ground-up rendezvous flights, also considered a rendezvous phasing burn

**NC (Rendezvous phasing)** - Performed to hit a range relative to the target at a future time

**NH (Rendezvous height adjust)** - Performed to hit a delta-height relative to the target at a future time

**NPC (Rendezvous plane change)** - Performed to remove planar errors relative to the target at a future time

**NCC (Rendezvous corrective combination)** - First on-board targeted burn in the rendezvous sequence. Using star tracker data, it is performed to remove phasing and height errors relative to the target at  $T_i$

**Ti (Rendezvous terminal intercept)** - Second on-board targeted burn in the rendezvous sequence. Using primarily rendezvous radar data, it places the Orbiter on a trajectory to intercept the target in one orbit

**MC-1, MC-2, MC-3, MC-4 (Rendezvous midcourse burns)** - These on-board targeted burns use star tracker and rendezvous radar data to correct the post- $T_i$  trajectory in preparation for the final, manual proximity operations phase

Updated: 05/22/2001

## Shuttle Reference Data

### Space Shuttle Solid Rocket Boosters

The two SRBs provide the main thrust to lift the space shuttle off the pad and up to an altitude of about 150,000 feet, or 24 nautical miles (28 statute miles). In addition, the two SRBs carry the entire weight of the external tank and orbiter and transmit the weight load through their structure to the mobile launcher platform.

Each booster has a thrust (sea level) of approximately 3,300,000 pounds at launch. They are ignited after the three space shuttle main engines' thrust level is verified. The two SRBs provide 71.4 percent of the thrust at lift-off and during first-stage ascent. Seventy-five seconds after SRB separation, SRB apogee occurs at an altitude of approximately 220,000 feet, or 35 nautical miles (40 statute miles). SRB impact occurs in the ocean approximately 122 nautical miles (140 statute miles) downrange.

The SRBs are the largest solid-propellant motors ever flown and the first designed for reuse. Each is 149.16 feet long and 12.17 feet in diameter.

Each SRB weighs approximately 1,300,000 pounds at launch. The propellant for each solid rocket motor weighs approximately 1,100,000 pounds. The inert weight of each SRB is approximately 192,000 pounds.

Primary elements of each booster are the motor (including case, propellant, igniter and nozzle), structure, separation systems, operational flight instrumentation, recovery avionics, pyrotechnics, deceleration system, thrust vector control system and range safety destruct system.

Each booster is attached to the external tank at the SRB's aft frame by two lateral sway braces and a diagonal attachment. The forward end of each SRB is attached to the external tank at the forward end of the SRB's forward skirt. On the launch pad, each booster also is attached to the mobile launcher platform at the aft skirt by four bolts and nuts that are severed by small explosives at lift-off.

During the downtime following the Challenger accident, detailed structural analyses were performed on critical structural elements of the SRB. Analyses were primarily focused in areas where anomalies had been noted during postflight inspection of recovered hardware.

One of the areas was the attach ring where the SRBs are connected to the external tank. Areas of distress were noted in some of the fasteners where the ring attaches to the SRB motor case. This situation was attributed to the high loads encountered during water impact. To correct the situation and ensure higher strength margins during ascent, the attach ring was redesigned to encircle the motor case completely (360 degrees). Previously, the attach ring formed a C and encircled the motor case 270 degrees.

## STS-109

---

Additionally, special structural tests were performed on the aft skirt. During this test program, an anomaly occurred in a critical weld between the hold-down post and skin of the skirt. A redesign was implemented to add reinforcement brackets and fittings in the aft ring of the skirt.

These two modifications added approximately 450 pounds to the weight of each SRB.

The propellant mixture in each SRB motor consists of an ammonium perchlorate (oxidizer, 69.6 percent by weight), aluminum (fuel, 16 percent), iron oxide (a catalyst, 0.4 percent), a polymer (a binder that holds the mixture together, 12.04 percent), and an epoxy curing agent (1.96 percent). The propellant is an 11-point star-shaped perforation in the forward motor segment and a double-truncated-cone perforation in each of the aft segments and aft closure. This configuration provides high thrust at ignition and then reduces the thrust by approximately a third 50 seconds after lift-off to prevent overstressing the vehicle during maximum dynamic pressure.

The SRBs are used as matched pairs and each is made up of four solid rocket motor segments. The pairs are matched by loading each of the four motor segments in pairs from the same batches of propellant ingredients to minimize any thrust imbalance. The segmented-casing design assures maximum flexibility in fabrication and ease of transportation and handling. Each segment is shipped to the launch site on a heavy-duty rail car with a specially built cover.

The nozzle expansion ratio of each booster beginning with the STS-8 mission is 7-to-79. The nozzle is gimballed for thrust vector (direction) control. Each SRB has its own redundant auxiliary power units and hydraulic pumps. The all-axis gimbaling capability is 8 degrees. Each nozzle has a carbon cloth liner that erodes and chars during firing. The nozzle is a convergent-divergent, movable design in which an aft pivot-point flexible bearing is the gimbal mechanism.

The cone-shaped aft skirt reacts the aft loads between the SRB and the mobile launcher platform. The four aft separation motors are mounted on the skirt. The aft section contains avionics, a thrust vector control system that consists of two auxiliary power units and hydraulic pumps, hydraulic systems and a nozzle extension jettison system.

The forward section of each booster contains avionics, a sequencer, forward separation motors, a nose cone separation system, drogue and main parachutes, a recovery beacon, a recovery light, a parachute camera on selected flights and a range safety system.

Each SRB has two integrated electronic assemblies, one forward and one aft. After burnout, the forward assembly initiates the release of the nose cap and frustum and turns on the recovery aids. The aft assembly, mounted in the external tank/SRB attach ring, connects with the forward assembly and the orbiter avionics systems for SRB ignition commands and nozzle thrust vector control. Each integrated electronic assembly has a multiplexer/ demultiplexer, which sends or receives more than one message, signal or unit of information on a single communication channel.

# STS-109

---

Eight booster separation motors (four in the nose frustum and four in the aft skirt) of each SRB thrust for 1.02 seconds at SRB separation from the external tank. Each solid rocket separation motor is 31.1 inches long and 12.8 inches in diameter.

Location aids are provided for each SRB, frustum/drogue chutes and main parachutes. These include a transmitter, antenna, strobe/converter, battery and salt water switch electronics. The location aids are designed for a minimum operating life of 72 hours and when refurbished are considered usable up to 20 times. The flashing light is an exception. It has an operating life of 280 hours. The battery is used only once.

The SRB nose caps and nozzle extensions are not recovered.

The recovery crew retrieves the SRBs, frustum/drogue chutes, and main parachutes. The nozzles are plugged, the solid rocket motors are dewatered, and the SRBs are towed back to the launch site. Each booster is removed from the water, and its components are disassembled and washed with fresh and deionized water to limit salt water corrosion. The motor segments, igniter and nozzle are shipped back to Thiokol for refurbishment.

Each SRB incorporates a range safety system that includes a battery power source, receiver/ decoder, antennas and ordnance.

## **HOLD-DOWN POSTS**

Each solid rocket booster has four hold-down posts that fit into corresponding support posts on the mobile launcher platform. Hold-down bolts hold the SRB and launcher platform posts together. Each bolt has a nut at each end, but only the top nut is frangible. The top nut contains two NASA standard detonators, which are ignited at solid rocket motor ignition commands.

When the two NSDs are ignited at each hold-down, the hold-down bolt travels downward because of the release of tension in the bolt (pretensioned before launch), NSD gas pressure and gravity. The bolt is stopped by the stud deceleration stand, which contains sand. The SRB bolt is 28 inches long and is 3.5 inches in diameter. The frangible nut is captured in a blast container.

The solid rocket motor ignition commands are issued by the orbiter's computers through the master events controllers to the hold-down pyrotechnic initiator controllers on the mobile launcher platform. They provide the ignition to the hold-down NSDs. The launch processing system monitors the SRB hold-down PICs for low voltage during the last 16 seconds before launch. PIC low voltage will initiate a launch hold.

## **SRB IGNITION**

SRB ignition can occur only when a manual lock pin from each SRB safe and arm device has been removed. The ground crew removes the pin during prelaunch activities. At T minus five minutes, the SRB safe and arm device is rotated to the arm position. The solid rocket motor ignition commands are issued when the three SSMEs are at or above 90-percent rated thrust, no SSME fail and/or SRB ignition PIC low voltage is indicated and there are no holds from the LPS.

# STS-109

---

The solid rocket motor ignition commands are sent by the orbiter computers through the MECs to the safe and arm device NSDs in each SRB. A PIC single-channel capacitor discharge device controls the firing of each pyrotechnic device. Three signals must be present simultaneously for the PIC to generate the pyro firing output. These signals--arm, fire 1 and fire 2--originate in the orbiter general-purpose computers and are transmitted to the MECs. The MECs reformat them to 28-volt dc signals for the PICs. The arm signal charges the PIC capacitor to 40 volts dc (minimum of 20 volts dc).

The fire 2 commands cause the redundant NSDs to fire through a thin barrier seal down a flame tunnel. This ignites a pyro booster charge, which is retained in the safe and arm device behind a perforated plate. The booster charge ignites the propellant in the igniter initiator; and combustion products of this propellant ignite the solid rocket motor initiator, which fires down the length of the solid rocket motor igniting the solid rocket motor propellant.

The GPC launch sequence also controls certain critical main propulsion system valves and monitors the engine-ready indications from the SSMEs. The MPS start commands are issued by the onboard computers at T minus 6.6 seconds (staggered start--engine three, engine two, engine one--all approximately within 0.25 of a second), and the sequence monitors the thrust buildup of each engine. All three SSMEs must reach the required 90-percent thrust within three seconds; otherwise, an orderly shutdown is commanded and safing functions are initiated.

Normal thrust buildup to the required 90-percent thrust level will result in the SSMEs being commanded to the lift-off position at T minus three seconds as well as the fire 1 command being issued to arm the SRBs. At T minus three seconds, the vehicle base bending load modes are allowed to initialize (movement of approximately 25.5 inches measured at the tip of the external tank, with movement towards the external tank).

At T minus zero, the two SRBs are ignited, under command of the four onboard computers; separation of the four explosive bolts on each SRB is initiated (each bolt is 28 inches long and 3.5 inches in diameter); the two T-0 umbilicals (one on each side of the spacecraft) are retracted; the onboard master timing unit, event timer and mission event timers are started; the three SSMEs are at 100 percent; and the ground launch sequence is terminated.

The solid rocket motor thrust profile is tailored to reduce thrust during the maximum dynamic pressure region.

## **ELECTRICAL POWER DISTRIBUTION**

Electrical power distribution in each SRB consists of orbiter-supplied main dc bus power to each SRB via SRB buses A, B and C. Orbiter main dc buses A, B and C supply main dc bus power to corresponding SRB buses A, B and C. In addition, orbiter main dc bus C supplies backup power to SRB buses A and B, and orbiter bus B supplies backup power to SRB bus C. This electrical power distribution arrangement allows all SRB buses to remain powered in the event one orbiter main bus fails.

The nominal dc voltage is 28 volts dc, with an upper limit of 32 volts dc and a lower limit of 24 volts dc.

## HYDRAULIC POWER UNITS

There are two self-contained, independent HPUs on each SRB. Each HPU consists of an auxiliary power unit, fuel supply module, hydraulic pump, hydraulic reservoir and hydraulic fluid manifold assembly. The APUs are fueled by hydrazine and generate mechanical shaft power to a hydraulic pump that produces hydraulic pressure for the SRB hydraulic system. The two separate HPUs and two hydraulic systems are located on the aft end of each SRB between the SRB nozzle and aft skirt. The HPU components are mounted on the aft skirt between the rock and tilt actuators. The two systems operate from T minus 28 seconds until SRB separation from the orbiter and external tank. The two independent hydraulic systems are connected to the rock and tilt servoactuators.

The APU controller electronics are located in the SRB aft integrated electronic assemblies on the aft external tank attach rings.

The APUs and their fuel systems are isolated from each other. Each fuel supply module (tank) contains 22 pounds of hydrazine. The fuel tank is pressurized with gaseous nitrogen at 400 psi, which provides the force to expel (positive expulsion) the fuel from the tank to the fuel distribution line, maintaining a positive fuel supply to the APU throughout its operation.

The fuel isolation valve is opened at APU startup to allow fuel to flow to the APU fuel pump and control valves and then to the gas generator. The gas generator's catalytic action decomposes the fuel and creates a hot gas. It feeds the hot gas exhaust product to the APU two-stage gas turbine. Fuel flows primarily through the startup bypass line until the APU speed is such that the fuel pump outlet pressure is greater than the bypass line's. Then all the fuel is supplied to the fuel pump.

The APU turbine assembly provides mechanical power to the APU gearbox. The gearbox drives the APU fuel pump, hydraulic pump and lube oil pump. The APU lube oil pump lubricates the gearbox. The turbine exhaust of each APU flows over the exterior of the gas generator, cooling it, and is then directed overboard through an exhaust duct.

When the APU speed reaches 100 percent, the APU primary control valve closes, and the APU speed is controlled by the APU controller electronics. If the primary control valve logic fails to the open state, the secondary control valve assumes control of the APU at 112-percent speed.

Each HPU on an SRB is connected to both servoactuators on that SRB. One HPU serves as the primary hydraulic source for the servoactuator, and the other HPU serves as the secondary hydraulics for the servoactuator. Each servoactuator has a switching valve that allows the secondary hydraulics to power the actuator if the primary hydraulic pressure drops below 2,050 psi. A switch contact on the switching valve will close when the valve is in the secondary position. When the valve is closed, a signal is sent to the APU controller that inhibits the 100-percent APU speed control logic and enables the 112-percent APU speed control logic. The 100-percent APU speed enables one APU/HPU to supply sufficient operating hydraulic pressure to both servoactuators of that SRB.



# STS-109

---

The APU 100-percent speed corresponds to 72,000 rpm, 110-percent to 79,200 rpm, and 112-percent to 80,640 rpm.

The hydraulic pump speed is 3,600 rpm and supplies hydraulic pressure of 3,050, plus or minus 50, psi. A high-pressure relief valve provides overpressure protection to the hydraulic system and relieves at 3,750 psi.

The APUs/HPUs and hydraulic systems are reusable for 20 missions.

## **THRUST VECTOR CONTROL**

Each SRB has two hydraulic gimbal servoactuators: one for rock and one for tilt. The servoactuators provide the force and control to gimbal the nozzle for thrust vector control.

The space shuttle ascent thrust vector control portion of the flight control system directs the thrust of the three shuttle main engines and the two SRB nozzles to control shuttle attitude and trajectory during lift-off and ascent. Commands from the guidance system are transmitted to the ATVC drivers, which transmit signals proportional to the commands to each servoactuator of the main engines and SRBs. Four independent flight control system channels and four ATVC channels control six main engine and four SRB ATVC drivers, with each driver controlling one hydraulic port on each main and SRB servoactuator.

Each SRB servoactuator consists of four independent, two-stage servovalves that receive signals from the drivers. Each servovalve controls one power spool in each actuator, which positions an actuator ram and the nozzle to control the direction of thrust.

The four servovalves in each actuator provide a force-summed majority voting arrangement to position the power spool. With four identical commands to the four servovalves, the actuator force-sum action prevents a single erroneous command from affecting power ram motion. If the erroneous command persists for more than a predetermined time, differential pressure sensing activates a selector valve to isolate and remove the defective servovalve hydraulic pressure, permitting the remaining channels and servovalves to control the actuator ram spool.

Failure monitors are provided for each channel to indicate which channel has been bypassed. An isolation valve on each channel provides the capability of resetting a failed or bypassed channel.

Each actuator ram is equipped with transducers for position feedback to the thrust vector control system. Within each servoactuator ram is a splashdown load relief assembly to cushion the nozzle at water splashdown and prevent damage to the nozzle flexible bearing.

## **SRB RATE GYRO ASSEMBLIES**

Each SRB contains two RGAs, with each RGA containing one pitch and one yaw gyro. These provide an output proportional to angular rates about the pitch and yaw axes to the orbiter computers and guidance, navigation and control system during first-stage ascent flight in conjunction with the orbiter roll rate gyros until SRB separation. At SRB separation, a switchover is made from the SRB RGAs to the orbiter RGAs.

# STS-109

---

The SRB RGA rates pass through the orbiter flight aft multiplexers/ demultiplexers to the orbiter GPCs. The RGA rates are then mid-value- selected in redundancy management to provide SRB pitch and yaw rates to the user software. The RGAs are designed for 20 missions.

## **SRB SEPARATION**

SRB separation is initiated when the three solid rocket motor chamber pressure transducers are processed in the redundancy management middle value select and the head-end chamber pressure of both SRBs is less than or equal to 50 psi. A backup cue is the time elapsed from booster ignition.

The separation sequence is initiated, commanding the thrust vector control actuators to the null position and putting the main propulsion system into a second-stage configuration (0.8 second from sequence initialization), which ensures the thrust of each SRB is less than 100,000 pounds. Orbiter yaw attitude is held for four seconds, and SRB thrust drops to less than 60,000 pounds.

The SRBs separate from the external tank within 30 milliseconds of the ordnance firing command.

The forward attachment point consists of a ball (SRB) and socket (ET) held together by one bolt. The bolt contains one NSD pressure cartridge at each end. The forward attachment point also carries the range safety system cross-strap wiring connecting each SRB RSS and the ET RSS with each other.

The aft attachment points consist of three separate struts: upper, diagonal and lower. Each strut contains one bolt with an NSD pressure cartridge at each end. The upper strut also carries the umbilical interface between its SRB and the external tank and on to the orbiter.

There are four booster separation motors on each end of each SRB. The BSMs separate the SRBs from the external tank. The solid rocket motors in each cluster of four are ignited by firing redundant NSD pressure cartridges into redundant confined detonating fuse manifolds.

The separation commands issued from the orbiter by the SRB separation sequence initiate the redundant NSD pressure cartridge in each bolt and ignite the BSMs to effect a clean separation.

Updated: 05/22/2001

## Shuttle Reference Data

### Space Shuttle Super Light Weight Tank (SLWT)

The super lightweight external tank (SLWT) made its first shuttle flight June 2, 1998, on mission STS-91. The SLWT is 7,500 pounds lighter than the standard external tank. The lighter weight tank will allow the shuttle to deliver International Space Station elements (such as the service module) into the proper orbit.

The SLWT is the same size as the previous design. But the liquid hydrogen tank and the liquid oxygen tank are made of aluminum lithium, a lighter, stronger material than the metal alloy used for the shuttle's current tank. The tank's structural design has also been improved, making it 30% stronger and 5% less dense.

The SLWT, like the standard tank, is manufactured at Michoud Assembly, near New Orleans, Louisiana, by Lockheed Martin.

The 154-foot-long external tank is the largest single component of the space shuttle. It stands taller than a 15-story building and has a diameter of about 27 feet. The external tank holds over 530,000 gallons of liquid hydrogen and liquid oxygen in two separate tanks. The hydrogen (fuel) and liquid oxygen (oxidizer) are used as propellants for the shuttle's three main engines.

Updated: 05/22/2001

## Acronyms and Abbreviations

ACS	Advanced Camera for Surveys
APE	Articulating PFR Extender
ASIPE	Axial Science Instrument Protective Enclosure
ASLR	Aft Shroud Latch Repair
ATM	Auxiliary Transport Module
BAPS	Berthing and Positioning System
BSP	Berthing and Positioning System (BAPS) Support Post
CASH	Cross Aft Shroud Harness
CATs	Crew Aids and Tools
CCD	Charge Coupled Device
CITE	Cargo Integrated Test Equipment
COSTAR	Corrective Optics Space Telescope Axial Replacement
CPL	Capillary Pump Loop
CVL	Cryo Vent Line
DBA	Diode Box Assembly
DBC	Diode Box Controller
EPS	Electrical Power Subsystem
ESM	Electronics Support Module
FDA	Failure Detection Annunciator
FHST	Fixed Head Star Tracker
FOC	Faint Object Camera
FSS	Flight Support System
HST	Hubble Space Telescope
IVT	Interface Verification Test
LED	Light Emitting Diode
LGA	Low Gain Antenna
LGAPC	Low Gain Antenna Protective Cover
LOPE	Large Orbital Replacement Unit Protective Enclosure
MFR	Manipulator Foot Restraint
MLI	Multi-Layer Insulation
MULE	Multi-Use Lightweight Equipment
NCC	NICMOS Cryo-Cooler
NCS	NICMOS Cooling System
NICMOS	Near Infrared Camera and Multi-Object Spectrometer

## STS-109

---

PCS	Pointing Control Subsystem
PCU	Power Control Unit
PCU-R	Power Control Unit-Replacement
PDM	Primary Deployment Mechanism
PDU	Power Distribution Unit
PFR	Portable Foot Restraint
PI	Payload Interrogator
RAC	Rigid Array Carrier
RWA	Reaction Wheel Assembly
SAC	Second Axial Carrier
SADA	Solar Array Drive Assembly
SSV	Space Shuttle Vehicle
TI	Transition Initiation
VPF	Vertical Processing Facility
WFPC2	Wide Field and Planetary Camera 2

## Media Assistance

### NASA Television Transmission

NASA Television is available through the GE2 satellite system which is located on Transponder 9C, at 85 degrees west longitude, frequency 3880.0 MHz, audio 6.8 MHz.

The schedule for television transmissions from the orbiter and for mission briefings will be available during the mission at Kennedy Space Center, Fla.; Marshall Space Flight Center, Huntsville, Ala.; Dryden Flight Research Center, Edwards, Calif.; Johnson Space Center, Houston, Texas; and NASA Headquarters, Washington, DC. The television schedule will be updated to reflect changes dictated by mission operations.

### Status Reports

Status reports on countdown and mission progress, on-orbit activities and landing operations will be produced by the appropriate NASA news center.

### Briefings

A mission press briefing schedule will be issued before launch. During the mission, status briefings by a flight director or mission operations representative and when appropriate, representatives from the payload team, will occur at least once each day. The updated NASA television schedule will indicate when mission briefings are planned.

### Internet Information

Information is available through several sources on the Internet. The primary source for mission information is the NASA Human Space Flight Web, part of the World Wide Web. This site contains information on the crew and its mission and will be updated regularly with status reports, photos and video clips throughout the flight. The NASA Shuttle Web's address is:

<http://spaceflight.nasa.gov>

General information on NASA and its programs is available through the NASA Home Page and the NASA Public Affairs Home Page:

<http://www.nasa.gov>

or

<http://www.nasa.gov/newsinfo/index.html>

Shuttle Pre-Launch Status Reports

<http://www-pao.ksc.nasa.gov/kscpao/status/stsstat/current.htm>

# STS-109

---

Information on other current NASA activities is available through the Today@NASA page:

<http://www.nasa.gov/today/index.html>

The NASA TV schedule is available from the NTV Home Page:

<http://spaceflight.nasa.gov/realdata/nasatv/schedule.html>

Resources for educators can be found at the following address:

<http://education.nasa.gov>

## **Access by CompuServe**

Users with CompuServe accounts can access NASA press releases by typing "GO NASA" (no quotes) and making a selection from the categories offered.

## Media Contacts

Dwayne Brown  
NASA Headquarters  
Washington, DC  
[Dwayne.brown@hq.nasa.gov](mailto:Dwayne.brown@hq.nasa.gov)  
Space Shuttle/Space Station Policy  
202-358-1726

Donald Savage  
NASA Headquarters  
Washington, DC  
[Donald.savage@hq.nasa.gov](mailto:Donald.savage@hq.nasa.gov)  
Space Science Policy, Budget  
202-358-1727

Eileen Hawley  
Johnson Space Center  
Houston, TX  
[Eileen.hawley1@jsc.nasa.gov](mailto:Eileen.hawley1@jsc.nasa.gov)  
Astronauts/Mission Operations  
281-483-5111

Nancy Neal  
Goddard Space Flight Center  
Greenbelt, MD  
[Nancy.G.Neal1@gsfc.nasa.gov](mailto:Nancy.G.Neal1@gsfc.nasa.gov)  
Payload and Science Operations and Servicing  
301-286-0039

Ray Villard  
Space Telescope Science Institute  
Baltimore, MD  
Hubble Science Program  
410-338-4514

George Diller  
Kennedy Space Center  
Kennedy Space Center, Fla.  
[George.Diller-1@ksc.nasa.gov](mailto:George.Diller-1@ksc.nasa.gov)  
Space Shuttle Launch Operations  
321-867-2468