

X-59

3D PRINT ASSEMBLY INSTRUCTIONS



Pre-Assembly Check List

If printed with a brim, make sure all edges are clean/undisturbed.

Pieces are designed to press fit together but glue is recommended for a permanent solution. Super-glue or hobby glue work well.

To make sure clearances are correct: fit together without glue first, then make any adjustments before gluing together.

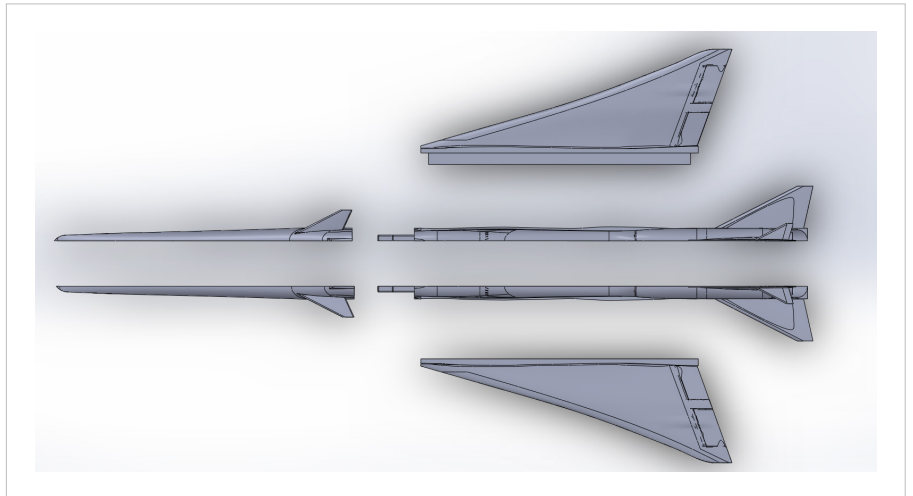

1

Fit Wings to Body Parts.

Left Wing → Body

Left Wing will fit into the open area on the left side of the body.

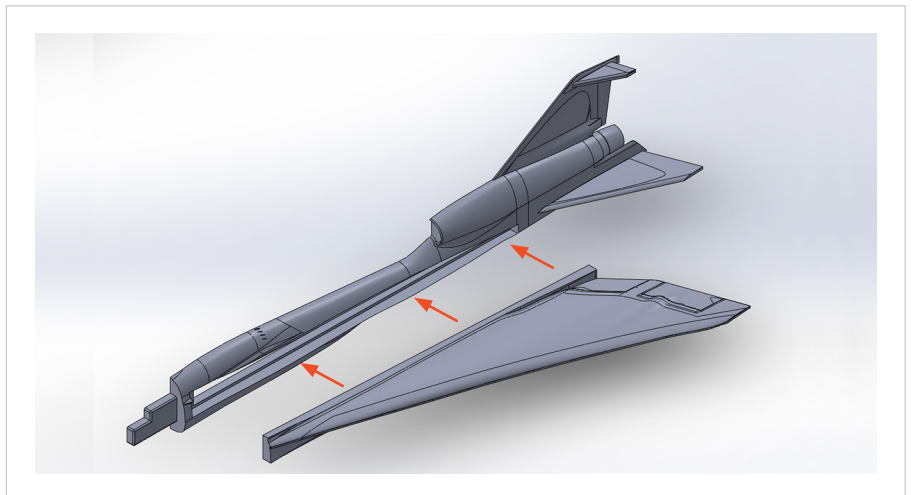

Right Wing → Body

Right Body has an opening that allows a longer section of the Right Wing to extend through both the Right and Left Body halves. Push the Right Wing into place on the Right Body section, making sure the wing piece extends through the body section.

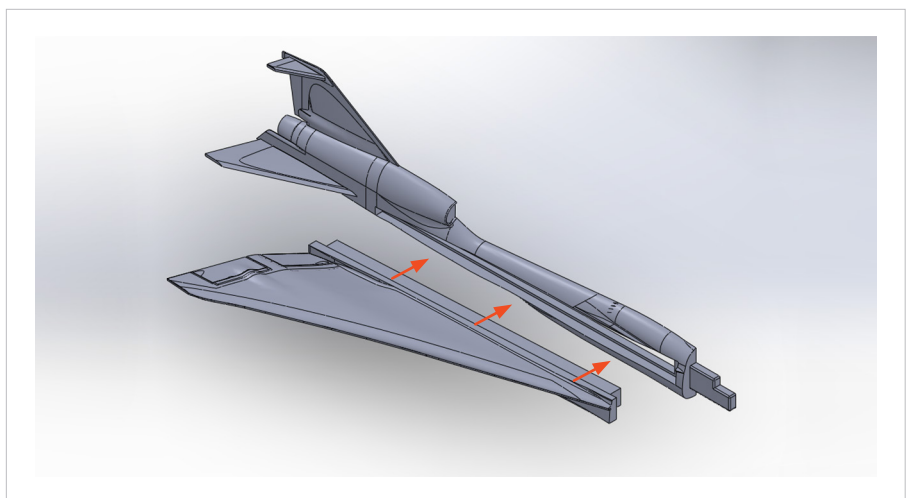

2

Joining Bodies

Push 2 halves together. The Right Wing section should also fit into part of the Left Body section, helping to better stabilize the model.

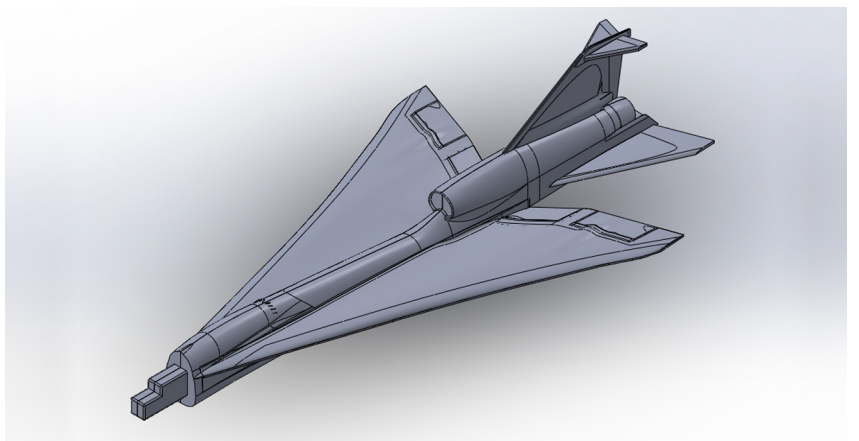
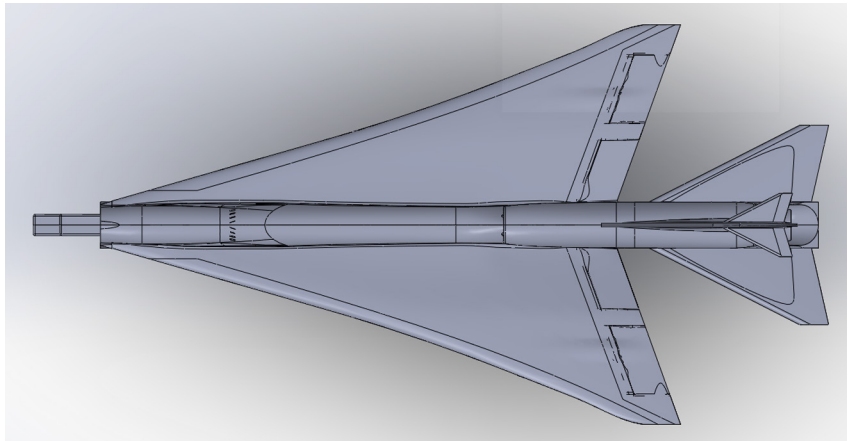
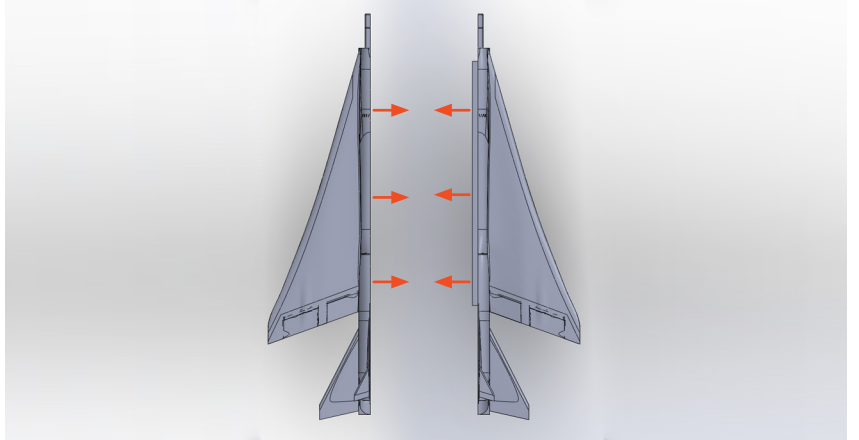

3

Attach Nose Pieces

Glue, sand, and finish your model.

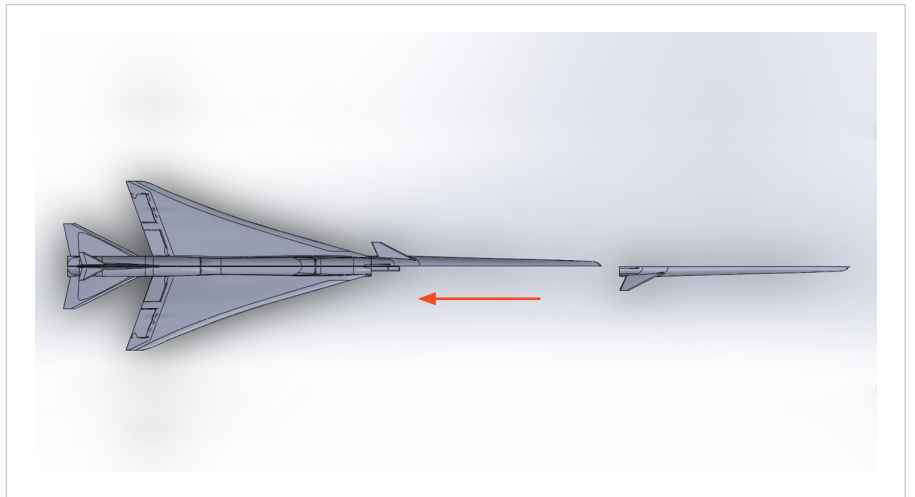
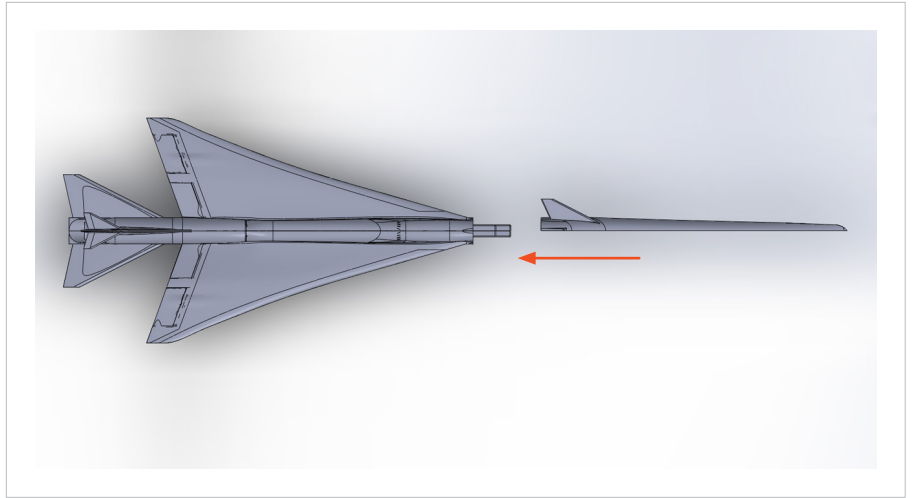

4

Finished model

You now have a completed model!

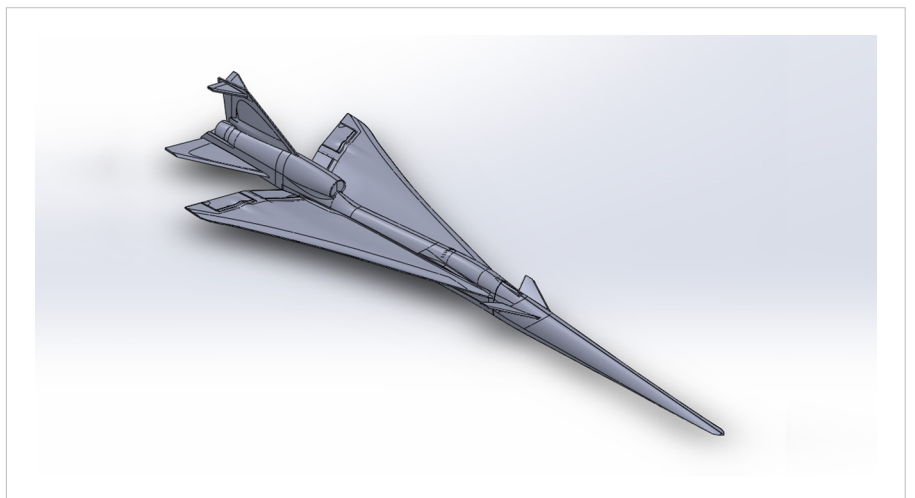

5

Adding Decals

A-H shows placement of the decals on the aircraft for both sides of the vehicle.

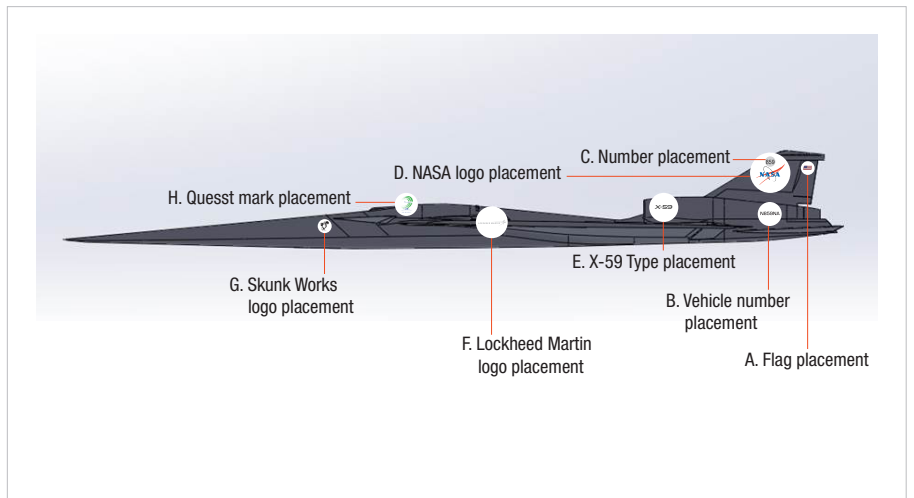
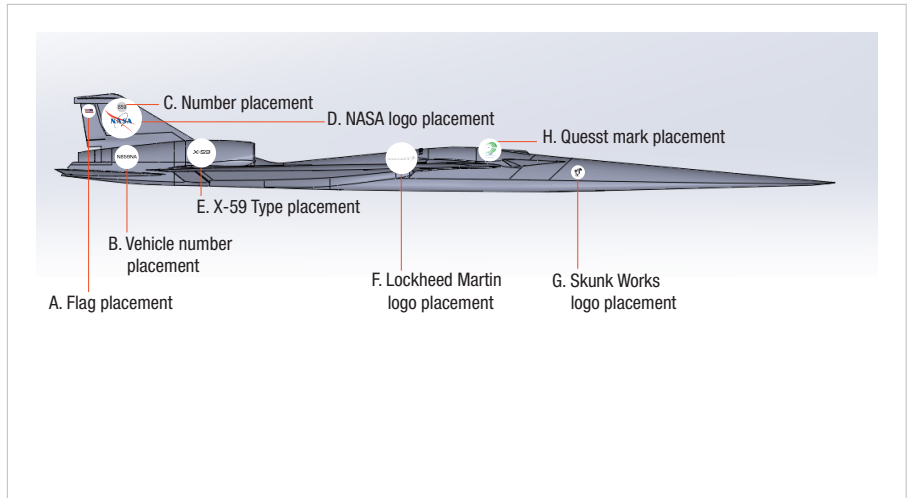

6

Model Stand
3-D Printed Model Stand



National Aeronautics and Space Administration

Headquarters

300 E. Street, SW

Washington, DC 20546

www.nasa.gov