

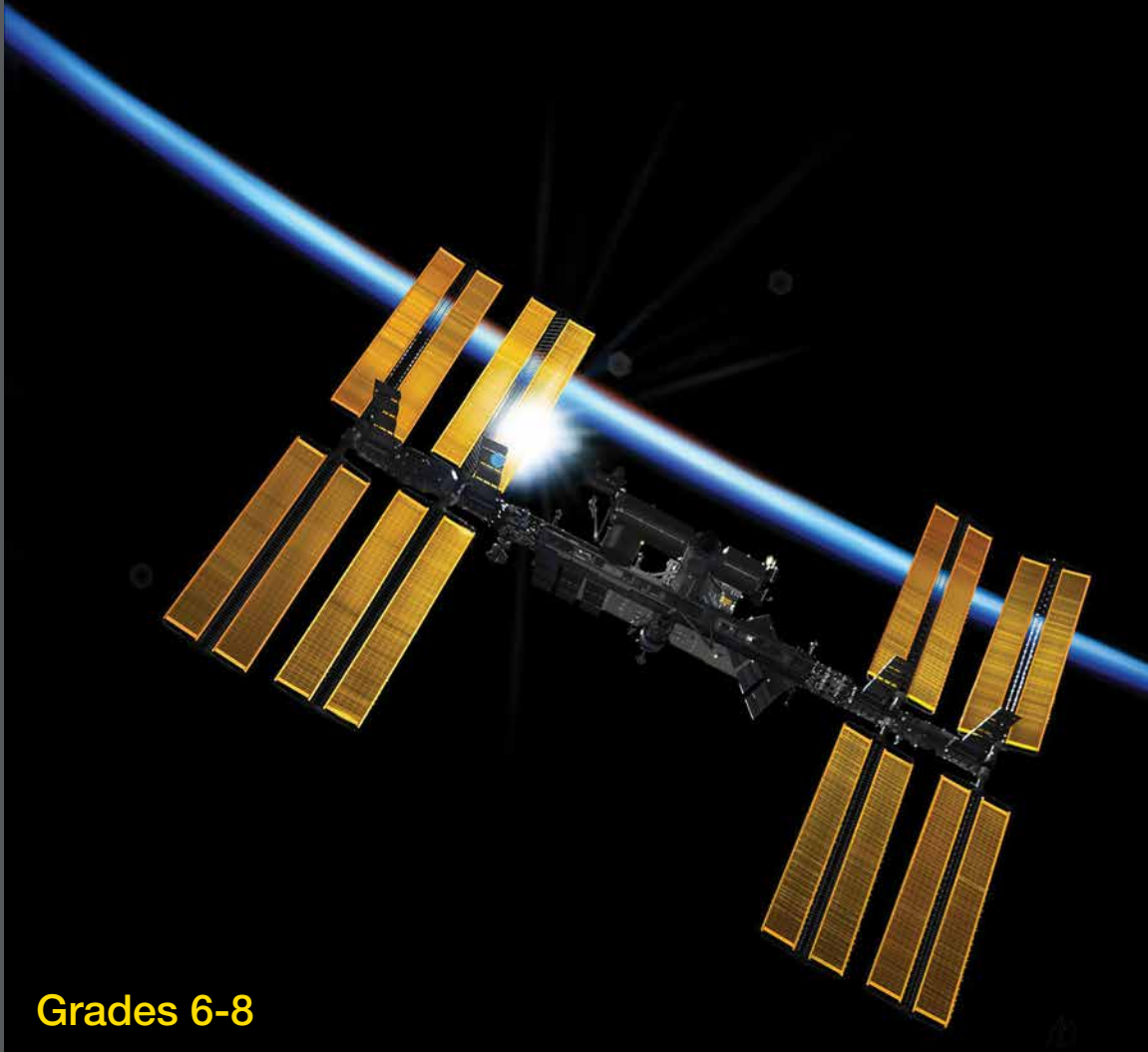

International Space Station Activity Book



Grades 6-8

This activity book belongs to:

>>> For more information, check out the web sites on page 30! <<<

Note to Teachers and Parents

This activity book is designed to appeal to students in grades 6-8. It is hoped that the activities presented herein will serve not only to convey information about the International Space Station, but about the challenges and rewards inherent in exploring space - both for the benefit of life on Earth, as well as for humankind's eventual expansion to the Moon, Mars, and the wonders which await us beyond. Through completion of fun activities, we hope to excite your students' imaginations, and engender in them an interest in math and science, culminating in their pursuit of space-related careers and/or hobbies. You are heartily invited to join your students as they work their way through the activities in this book - who knows, some of what they learn might just turn out to be new to you as well! Good luck, and have fun!

Space Symbols and Agency Acronyms

An acronym is a word that is made up of the initials of other words. Fill in the blank spaces to correctly identify the words in the NASA acronym. Use each of the missing letters below only once.

Then select your favorite red and blue crayons or markers and use the color key numbers as a guide to help you re-create the official NASA logo below.

N _ _ IO _ AL AE _ _ NA _ T _ CS & S _ _ C _ AD _ _ _ _ ST _ AT _ ON

Hint: the missing letters are: R, I, N, P, E, M, I, A, T, N, I, U, A, R, I, O

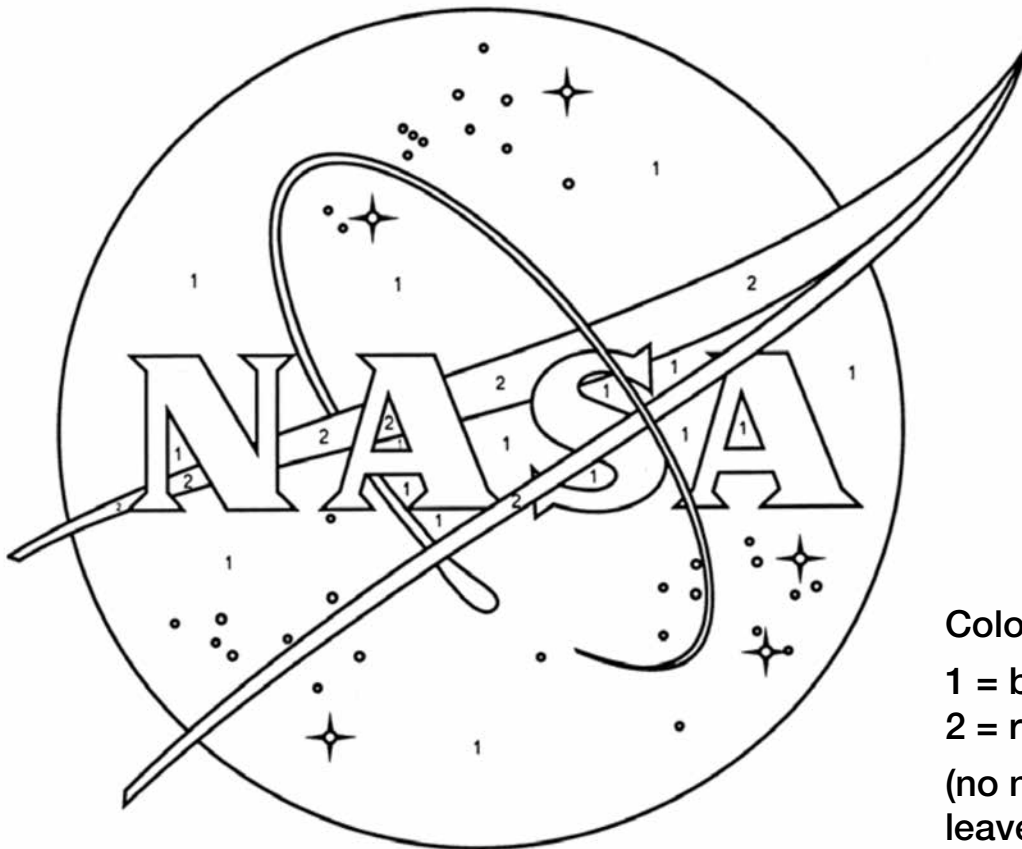

Color key:

1 = blue

2 = red

(no number –
leave white)

The NASA logo has symbolic meanings in its design. The blue sphere represents a planet; the stars represent space; the red chevron stands for aeronautics and a spacecraft orbits the NASA acronym.

President Dwight D. Eisenhower formed NASA on October 1, 1958 to give the United States a civilian air and space program. How old does that make NASA?

(Answers on page 32)

The States of NASA

In addition to the District of Columbia, there are 9 states within the United States that are home to one or more NASA facilities and space centers. After reviewing the map below, write each state's name by its correct number in the columns that follow.

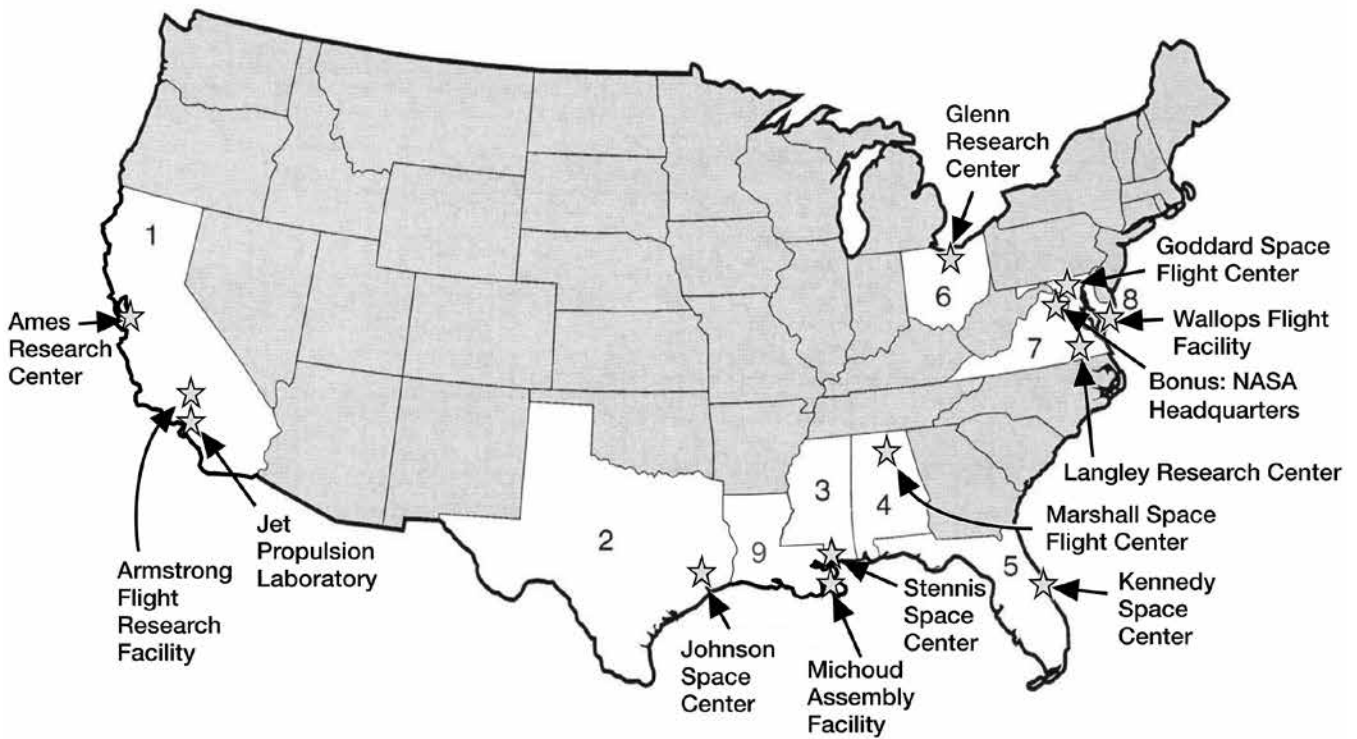

1) _____

4) _____

2) _____

5) _____

3) _____

6) _____

7) _____

8) _____

9) _____

Bonus: _____ *

*Home of NASA Headquarters (Hint: It's not a state, but the capital of the United States!)

(Answers on page 32)

Where is the International Space Station?

Look up in the sky at special times and you will see the Space Station, brighter than the planet Venus, moving quickly overhead as it goes around the Earth. When it's right above you, the Space Station is almost as far away from you as Dallas is from Houston – or Washington, DC is from New York City (about 250 miles), only straight up!

You can find out when the Space Station will be flying over you at: Spot the Station (<http://spotthestation.nasa.gov>).

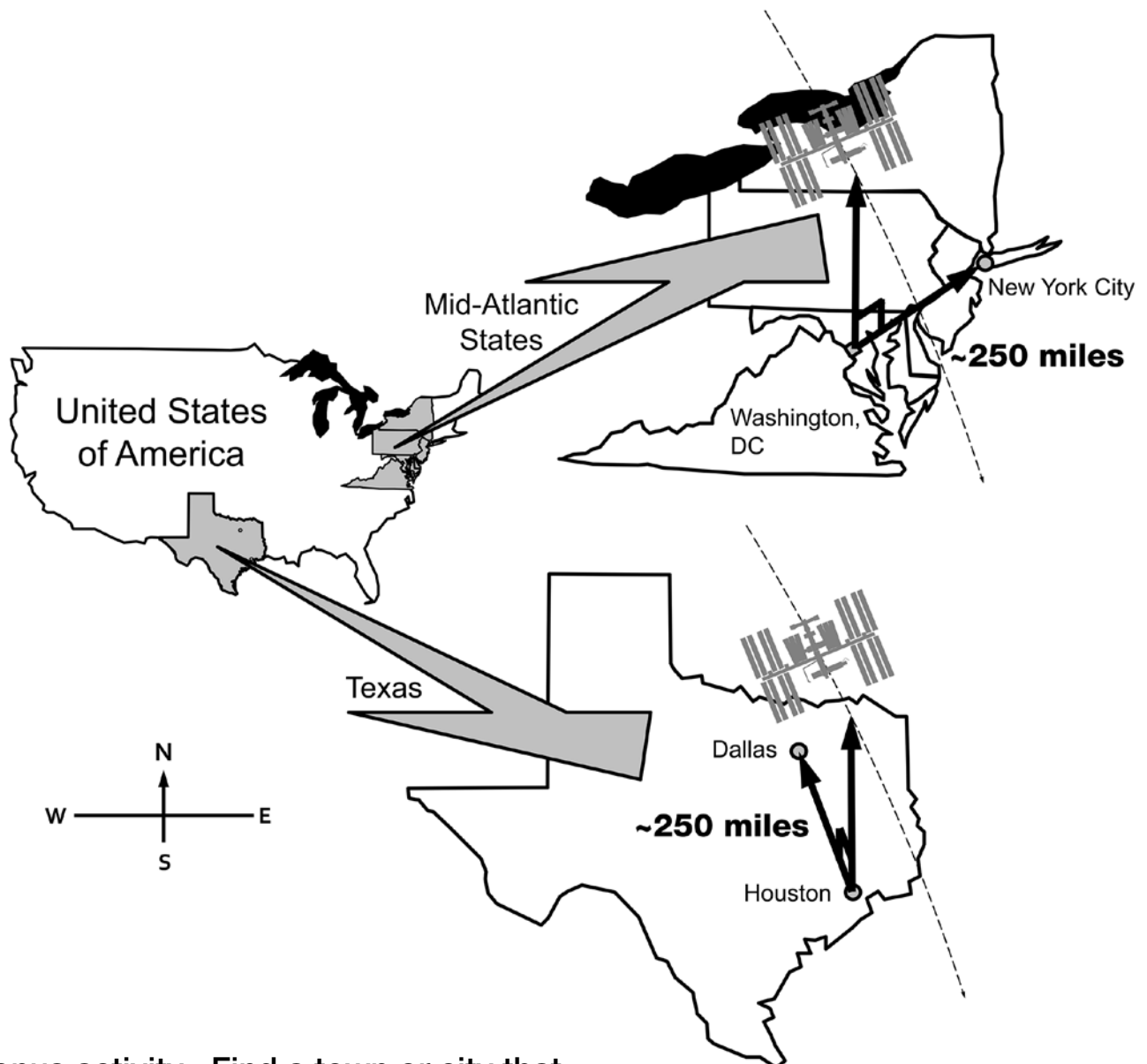

Bonus activity: Find a town or city that is about 250 miles from where you live...
Now imagine flying that high up...!

Did You Know...?

Let's learn some fun facts about the International Space Station!
Circle the right answer for each trivia question.

1. If you drew a rectangle around the Space Station like this dashed line, about how big would it be?
A: As big as a school bus
B: As big as 14 buses side-by-side
C: As big as a football field and its end-zones
D: Half as big as Rhode Island

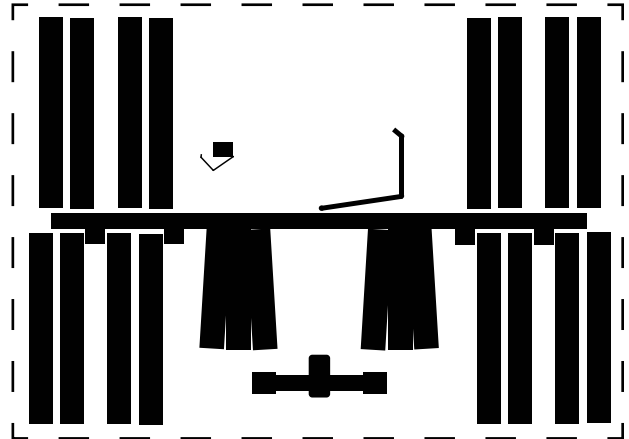

2. About how much does the Space Station weigh?
A: Nothing; it's weightless in space
B: A thousand pounds
C: Ten thousand pounds
D: A million pounds
3. About how fast does the Space Station go?
A: As fast as the speed of sound
B: 17,500 miles per hour
C: As fast as the speed of light
D: 35,000 miles per hour
4. About how often do astronauts on the Space Station see a sunrise?
A: Every hour-and-a-half
B: Never; the sun is always up
C: Once a day, just like we do
D: Every thirty minutes
5. When was the first piece of the Space Station launched into orbit?
A: 2010 B: 2004 C: 2001 D: 1998
6. How would your height on the Space Station compare to your height here on Earth? While on the Space Station, would you be:
A: Taller B: Shorter C: About the same
Bonus question: Why?

(Answers on page 32)

International Space Station Parts

Let's learn some of the main parts of the International Space Station!
Match each numbered part with its correct description:

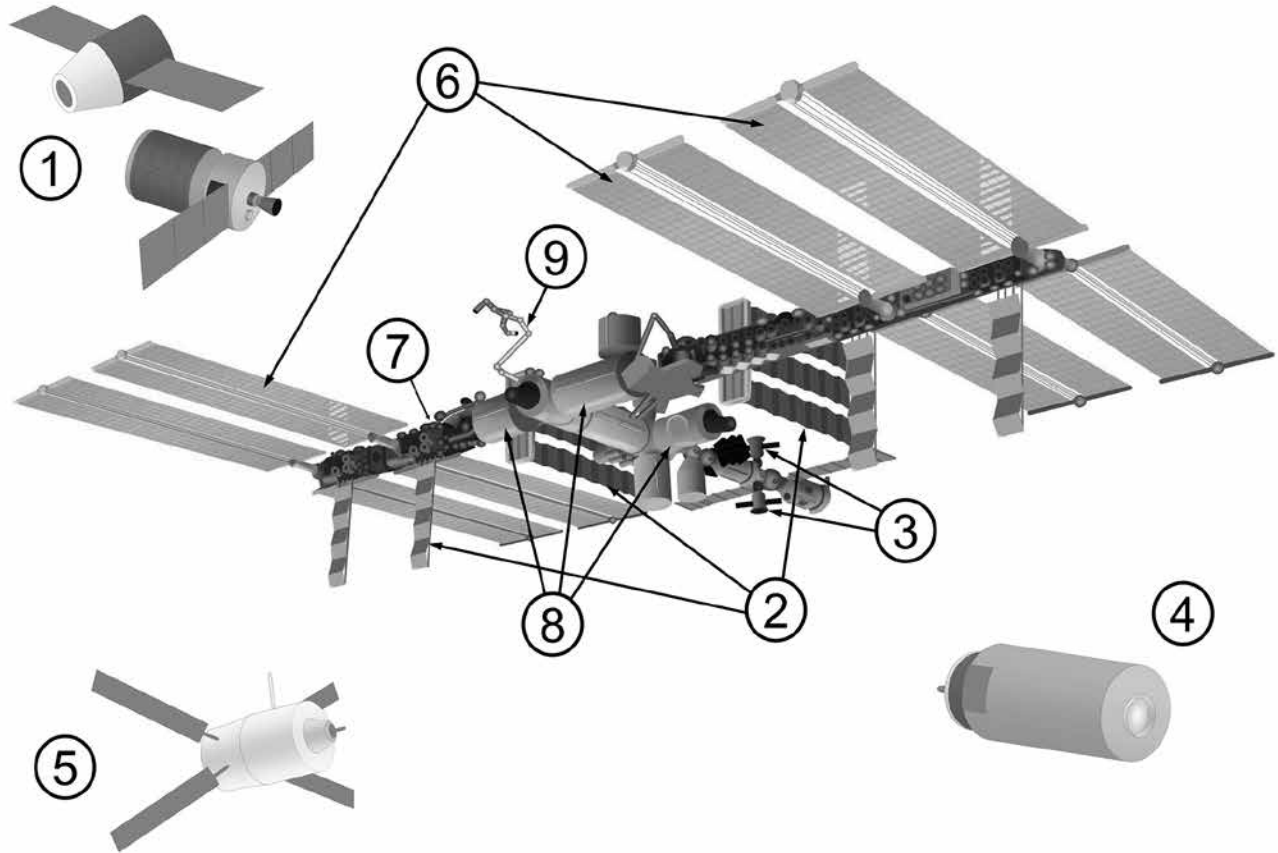

Write the part numbers in the blanks below, next to their descriptions:

- _____ **Solar arrays** (8 pairs) make electricity from sunlight and store it in batteries
- _____ **Truss** (big beam) holds solar arrays, radiators, and often the big robotic arm
- _____ **Radiators** get rid of heat from solar arrays and modules to keep things cool
- _____ Canada's big **robotic arm** moves people, parts and even spacecraft around
- _____ **Modules** (big soup can shaped parts) are where the astronauts live and work
- _____ **Soyuz** and **Progress** (Russian spacecraft) bring people, supplies and fuel
- _____ **ATV** (European spacecraft) is designed to bring supplies and fuel
- _____ **HTV** (Japanese spacecraft) is designed to bring supplies and spare parts
- _____ **Dragon, Cygnus** (American spacecraft) designed to bring people, parts, and/or supplies

(Answers on page 33)

International Space Station Partners

Let's learn who designed and built the International Space Station!

Color the flag of every country that helped build and supply the Space Station, using the color-by-number key below:

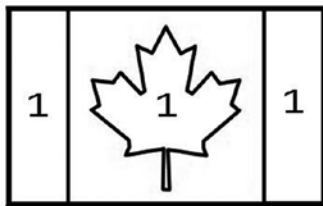

Canada

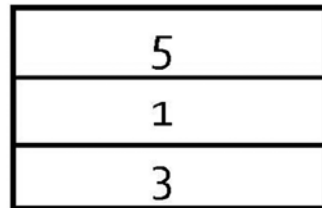

Germany

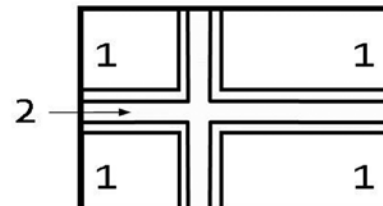

Norway

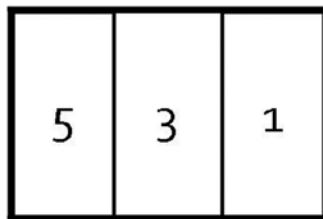

Belgium

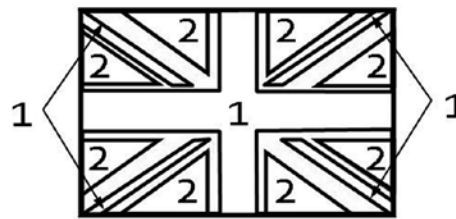

Great Britain

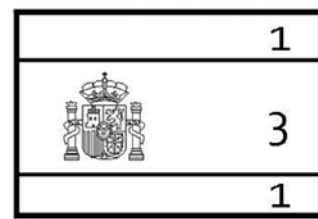

Spain

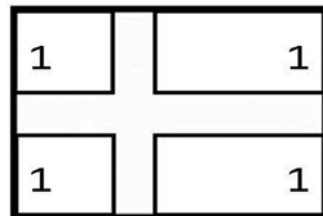

Denmark

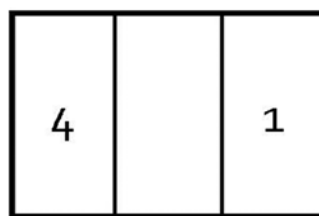

Italy

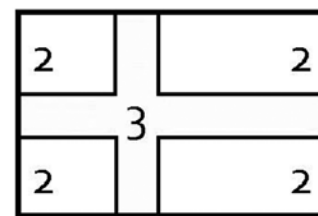

Sweden

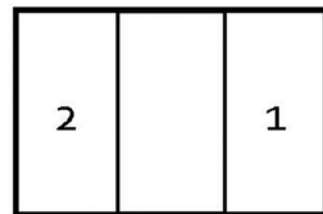

France

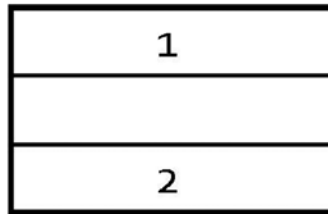

Netherlands

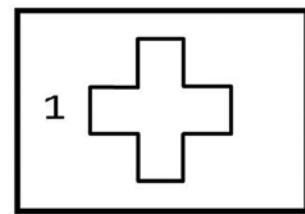

Switzerland

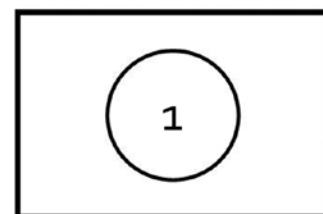

Japan

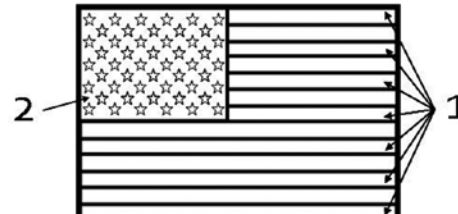

United States

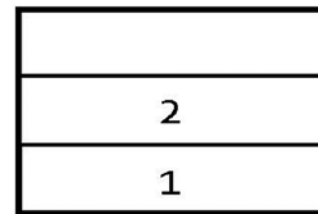

Russia

Color Key: 1 = red 2 = blue 3 = yellow 4 = green 5 = black

What is it Like to Build an International Space Station?

What were some special challenges faced by the people who designed and built the International Space Station?

Pick a country you've never visited: _____

Do people there speak your language? Yes ____ No ____

How far away is their country? Near ____ Far ____ Very far ____

How different is their culture from yours? A bit ____ Very ____

Now pretend you have to work with someone from that country to design a new spaceship...

What will be fun about your new job?

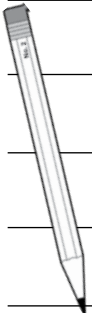

What might be hard about your new job?

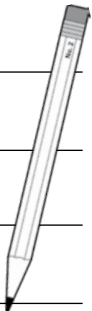

Join the Space Station Word Search!

Find the words listed below in the puzzle on the next page! Then check your Word Search solution against the answer key, and read about what they mean in the special language of life on the Station!

AIRLOCK - The special module that astronauts use to enter and leave the Space Station for spacewalks (see QUEST)

ASTRONAUT - The American word for space traveler

ATV - Automated Transfer Vehicle; the European spaceship that is designed to bring supplies and fuel to the Station

[] - Mystery entry for you to research: Slang term for the Japanese External Facility, where outside experiments are done (Hint: Sounds like a backyard-facing extension of a country house where folks might sit on rocking chairs and talk about the research being done on the Space Station...)

CANADA ARM - Canada's giant robotic arm ...makes sense, eh? Called 'Canadarm2' for short (the first Canadarm flew on the Shuttle)

COLUMBUS - Name given to Europe's laboratory module, in honor of Christopher Columbus

COSMONAUT - The Russian word for space traveler

CSA - The short form of 'Canadian Space Agency'

CUPOLA - Station's special windowed room with very clear glass so astronauts and instruments can see Earth and space

CYGNUS - American cargo spaceship designed to bring supplies to Station

DESTINY - Name given to America's laboratory module, which also controls most of Station's functions (see 'US Lab')

DRAGON - The first American spaceship to visit Station since the Space Shuttle; it is designed to bring people and supplies

ESA - The short form of 'European Space Agency'

FGB - Acronym describing the very first piece of the Space Station, launched by Russia in November 1998 (see 'Zarya')

HTV - H-2B (also known as 'Hope') Transfer Vehicle; the Japanese spaceship that is designed to bring supplies to the Station

JAXA - The short form of 'Japan Aerospace Exploration Agency'

KIBO - Name given to Japan's laboratory module, it means 'hope' in Japanese

LEONARDO - Name given to the European cargo container converted to be a Station module, in honor of Leonardo da Vinci

LOW EARTH ORBIT - What we call the distance above the Earth's surface just beyond the atmosphere; that's where Station is!

MIR - Russian for 'peace'; it was the name of the first Russian space station, which orbited Earth from 1986 to 2001

MPLM - Name (short for MultiPurpose Logistics Module) given to very large containers for experiments and supplies

MULTIPURPOSE LOGISTICS MODULE - See 'MPLM'; four of these were brought to and from the Station by the Space Shuttle

NASA - The short form of 'National Aeronautics and Space Administration' (America's space agency)

NODE - One of three hubs or connecting modules, each used on Station to attach several other modules together

PMA - Name (short for 'Pressurized Mating Adapter') given to the piece that allows spaceships to dock to Station

PRESSURIZED MATING ADAPTER - See 'PMA'; these special tunnel-like pieces allow people and supplies to move through them

PROGRESS - Name given to the Russian spaceship that brings supplies and fuel to the Space Station

QUEST - Name given to America's module that allows space-suited astronauts to leave and enter Station (see 'Airlock')

RADIATOR - Special parts that unfold and are designed to release heat into the coldness of space so Station doesn't overheat

RESEARCH - Collecting data and figuring out what it means, as a way of trying to understand better how things work

ROSCOSMOS - Name given to Russia's space agency

SCIENCE - Observing, studying, and experimenting to learn about how the universe and everything in it works

SERVICE MODULE - Russian module which is both a lab and Station's engine; it keeps Station going fast enough to stay in orbit

SKYLAB - Name given to America's first space station, which orbited Earth from 1973 to 1979

SOLAR ARRAY - Special parts that unfold and are designed to use the sun's energy to make electricity to power the Station

SOYUZ - Russian for 'union'; it is the name of Russia's spaceship that carries people to the Space Station and back again

SPACE SHUTTLE - American spaceship, now retired, used to launch most of the Station's pieces, as well as people and supplies

TRUSS SEGMENT - Part of the giant beam (or 'truss') which connects the solar arrays and radiators to the rest of Station

US LAB - The short form of 'United States Laboratory,' America's main research module (see 'Destiny')

ZARYA - Russian for 'dawn'; name given to the first piece of Station (see 'FGB')

ZVEZDA - Russian for 'star'; name given to the module that controls the Russian part of Station (see 'Service Module')

Welcome to the Space Station Word Search!

How many of the words from page 8 can you find?

(Hint: They can go up/down, left/right, diagonally, forward or backward!)

S	U	N	I	F	Y	T	I	N	V	X	N	T	U	N	C	U	P	U	L	A	I	R	T	H	C	R	E	P	K	C	A
T	Q	U	E	S	O	N	A	C	A	I	A	V	E	M	I	B	N	A	U	T	V	E	V	R	O	P	K	C	A	B	D
S	U	R	A	Y	R	D	I	A	T	S	O	M	S	O	C	S	O	R	O	T	A	T	O	C	S	U	I	N	H	Y	Z
L	E	O	N	A	R	G	O	T	U	Q	G	U	P	X	U	M	A	U	E	X	U	P	H	A	I	R	D	O	C	K	A
U	S	S	S	L	A	B	C	S	S	E	U	S	F	L	A	B	I	Q	U	E	C	A	H	C	R	A	E	S	E	R	V
Q	F	X	I	D	Y	D	U	S	S	E	A	S	C	B	E	Q	U	E	C	K	A	D	N	K	I	B	A	C	L	T	Z
U	D	A	A	R	N	X	Z	S	U	T	D	E	T	E	D	O	N	V	A	L	L	A	C	O	L	N	Y	A	U	A	A
E	A	N	J	I	T	A	S	E	G	S	E	G	M	E	M	T	N	B	T	Y	Z	G	O	O	R	I	T	N	D	N	Y
R	A	X	T	S	E	U	G	R	V	T	O	M	P	L	T	Y	T	A	A	N	O	N	W	E	L	T	V	A	O	A	J
T	R	Y	U	S	B	B	B	V	E	Z	V	E	Z	A	Z	J	V	J	R	E	O	I	A	A	O	U	S	O	M	U	Q
A	M	Q	A	S	F	D	G	I	U	V	A	N	B	K	E	B	O	E	M	D	Y	T	Q	R	W	O	M	A	S	T	U
X	A	R	S	R	C	Y	F	C	Q	E	S	T	I	I	U	A	T	X	J	L	O	A	U	T	R	S	B	A	C	U	P
A	Q	U	A	Y	R	A	Z	E	V	Z	X	B	K	B	Q	J	D	A	A	L	S	M	E	A	O	A	U	R	I	N	O
J	V	T	N	A	Y	A	B	M	E	O	O	A	C	U	A	U	T	S	K	E	L	D	S	Y	N	Y	S	N	T	C	L
Z	E	R	V	I	C	E	M	O	D	A	L	L	E	X	A	X	E	U	S	I	G	E	U	A	N	O	I	F	S	I	A
A	S	S	U	R	Y	T	U	D	V	D	U	S	L	A	P	A	J	N	A	H	B	Z	A	R	Y	U	M	G	I	M	X
R	T	S	B	L	E	R	Q	U	E	Z	T	S	R	J	A	X	O	G	T	O	C	I	R	Y	B	J	L	S	G	S	A
Y	S	A	S	O	B	U	K	L	S	E	R	U	I	C	E	N	O	Y	U	L	E	R	L	W	A	G	O	W	O	O	K
O	E	R	V	C	E	S	I	E	R	L	Y	U	A	I	R	L	U	C	K	L	G	U	O	X	L	B	W	O	L	C	I
S	C	V	S	K	A	T	B	S	D	A	A	R	M	K	U	Q	N	C	S	H	O	S	C	P	Y	F	E	L	E	O	B
K	U	A	T	R	V	S	S	Z	D	A	R	B	F	C	V	N	O	E	H	S	V	S	H	A	K	I	S	O	S	L	A
Y	P	T	V	R	Q	E	I	M	A	A	R	M	J	A	X	L	T	L	L	C	E	E	Z	Y	S	C	K	D	O	U	R
L	O	V	I	A	U	G	L	G	V	I	A	M	R	N	R	A	Y	E	A	T	R	R	U	T	I	I	A	S	P	M	G
A	L	L	Y	R	E	S	L	E	T	Z	R	R	Z	A	R	I	A	M	N	O	T	P	G	E	H	A	D	B	R	B	O
N	A	D	A	A	R	M	S	S	I	M	A	N	M	D	A	O	M	R	P	A	Q	U	N	O	R	L	V	A	U	O	R
S	S	D	N	A	T	E	L	S	M	S	L	R	N	A	E	D	T	C	M	Y	U	C	H	M	R	A	Z	A	P	S	P
K	U	K	R	O	V	N	A	L	E	U	O	P	Y	A	A	D	A	A	R	M	E	T	Y	S	I	P	E	B	I	K	O
Y	I	B	Y	A	D	T	E	N	E	G	S	I	M	P	U	B	U	N	I	S	S	U	H	A	E	U	Z	E	T	A	B
A	Z	B	M	Y	G	F	A	A	R	N	M	B	L	M	Q	U	E	Z	A	D	D	A	P	Y	A	C	D	V	L	L	A
S	U	B	M	U	L	O	C	R	R	A	Y	E	L	E	R	B	A	V	S	C	A	N	R	A	O	X	A	J	U	Y	L
A	Y	C	U	P	L	A	N	Z	E	W	Z	L	N	N	T	I	B	R	O	H	T	R	A	E	W	O	L	P	M	B	F
T	I	P	U	R	P	O	B	E	L	O	G	I	S	T	I	K	S	N	O	D	U	L	E	B	Z	A	R	Y	S	K	Y

(Solution on page 33)

Letter Shuffle

How many words can you make from the letters in



SPACE STATION?

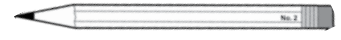

(Some examples are given on page 34)

What's in a Name?

The names we give the things we build often say a lot about us. Using page 8 as a reference, solve the clues below and complete the crossword puzzle!

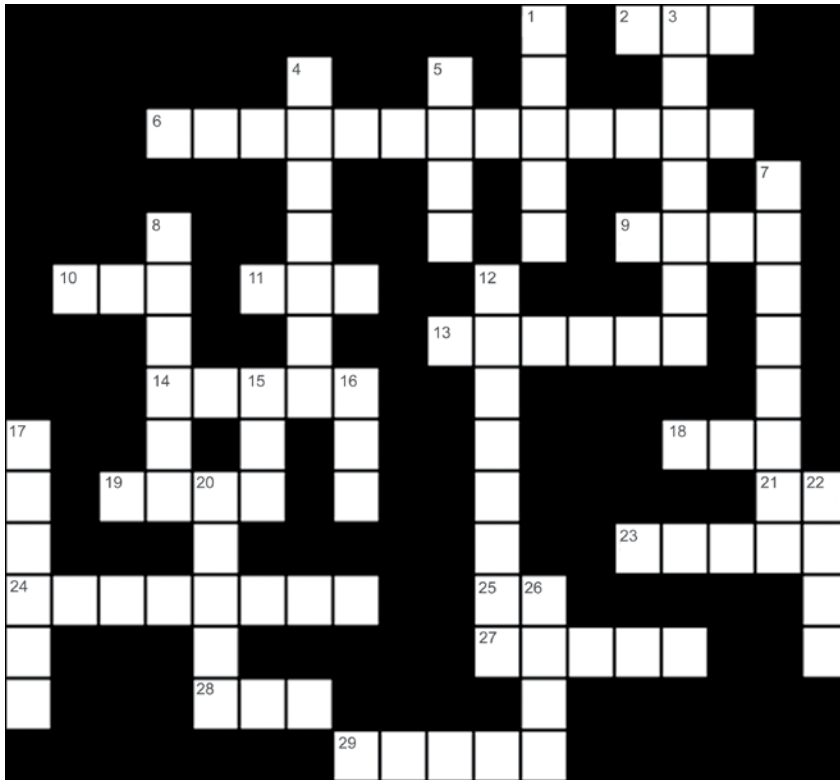

ACROSS

2. Short for 'Canadian Space Agency'
6. _____ Space Station
9. Name of Japanese module; it means 'hope' in Japanese
10. Short form of the name of Japanese supply spaceship
11. Name of Russia's first space station; it means 'peace' in Russian
13. Name of America's first rocket to visit Space Station since Shuttle was retired
14. Russian name given to the FGB; it means 'dawn'
18. The original name of the first piece of the Space Station to be launched
19. Short for the name of America's space agency
21. Short for the _____ of America, leader of the Space Station program
23. Name of America's Airlock module
24. Name of European supply container later converted to permanent module
25. What your teachers say if they want your class to do this puzzle more quietly
27. Name of Russian spaceship that takes people to the Space Station; it means 'union'
28. Short for 'European Space Agency'
29. What the name of Russia's first space station means in English

DOWN

1. Name of the first American piece, also launched in 1998; it means 'oneness'
3. International Space _____
4. Name of the US Lab
5. Short form of the name of Japan's space agency
7. Name of the European lab
8. Russian name given to the Service Module; it means 'star'
12. Name of the Russian supply spaceship; it looks the same in English
15. Short for 'Russian Space Agency'
16. Short form of the name of Europe's supply spaceship
17. Name of America's first space station
20. International ____ Station
22. What you wish upon...; also, what the Russian name of the Service Module means in English
26. What 'Kibo' means, to the Japanese



(Solution on page 35)

Draw the International Space Station!

Connect the dots in order of their numbers and see your very own Space Station take shape! Then color it any way you like!

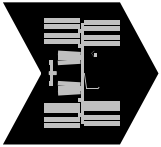

Bonus challenge: Sketch in and color the Earth! Over which continent or ocean is your Space Station flying?

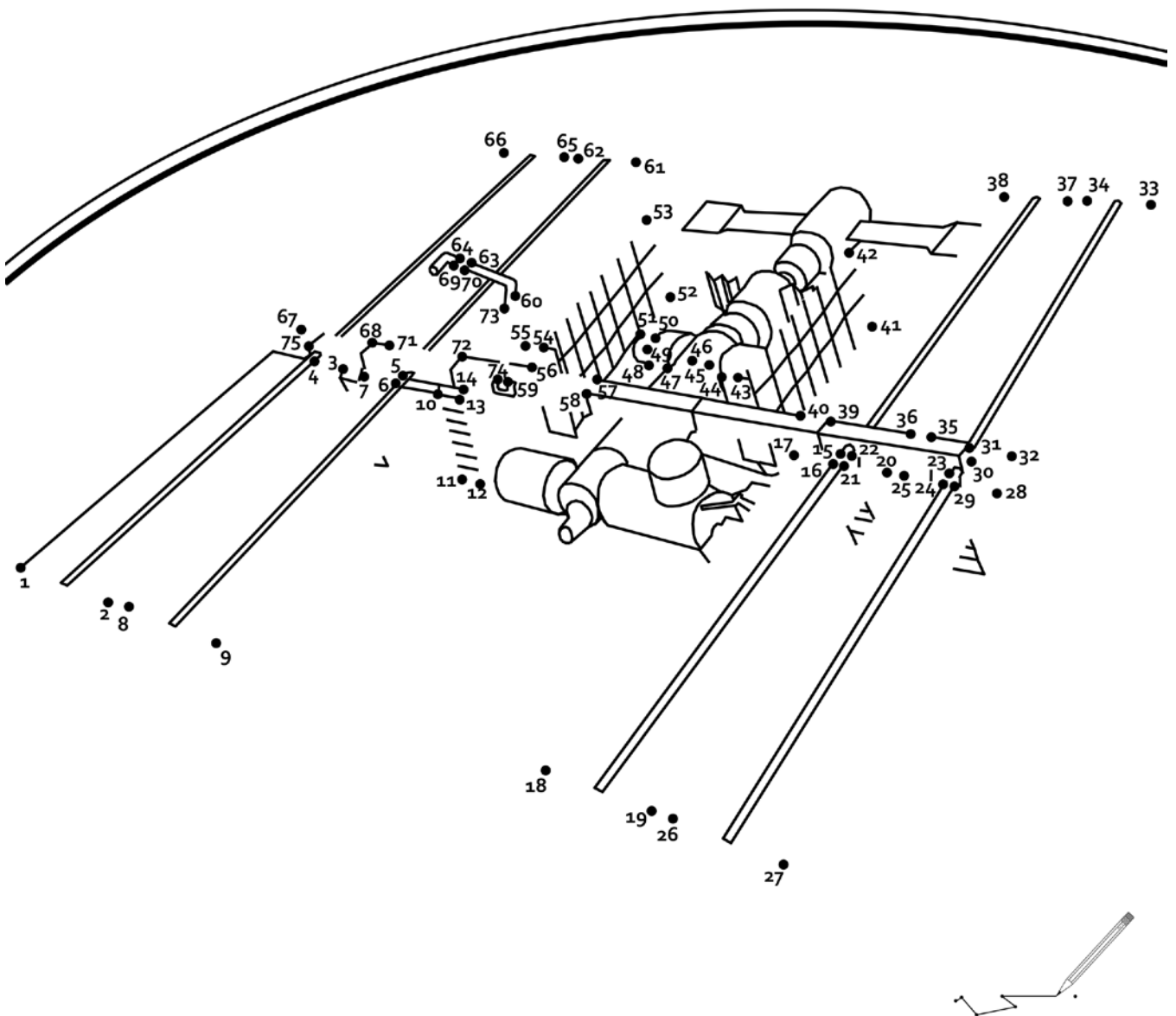
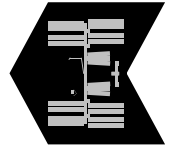

(Solution on page 35)

What's Different?

Astronauts need to have a keen eye for details when doing experiments or solving problems on the Space Station.

Find all thirteen differences between these pictures!

Circle everything on B that's different from A:

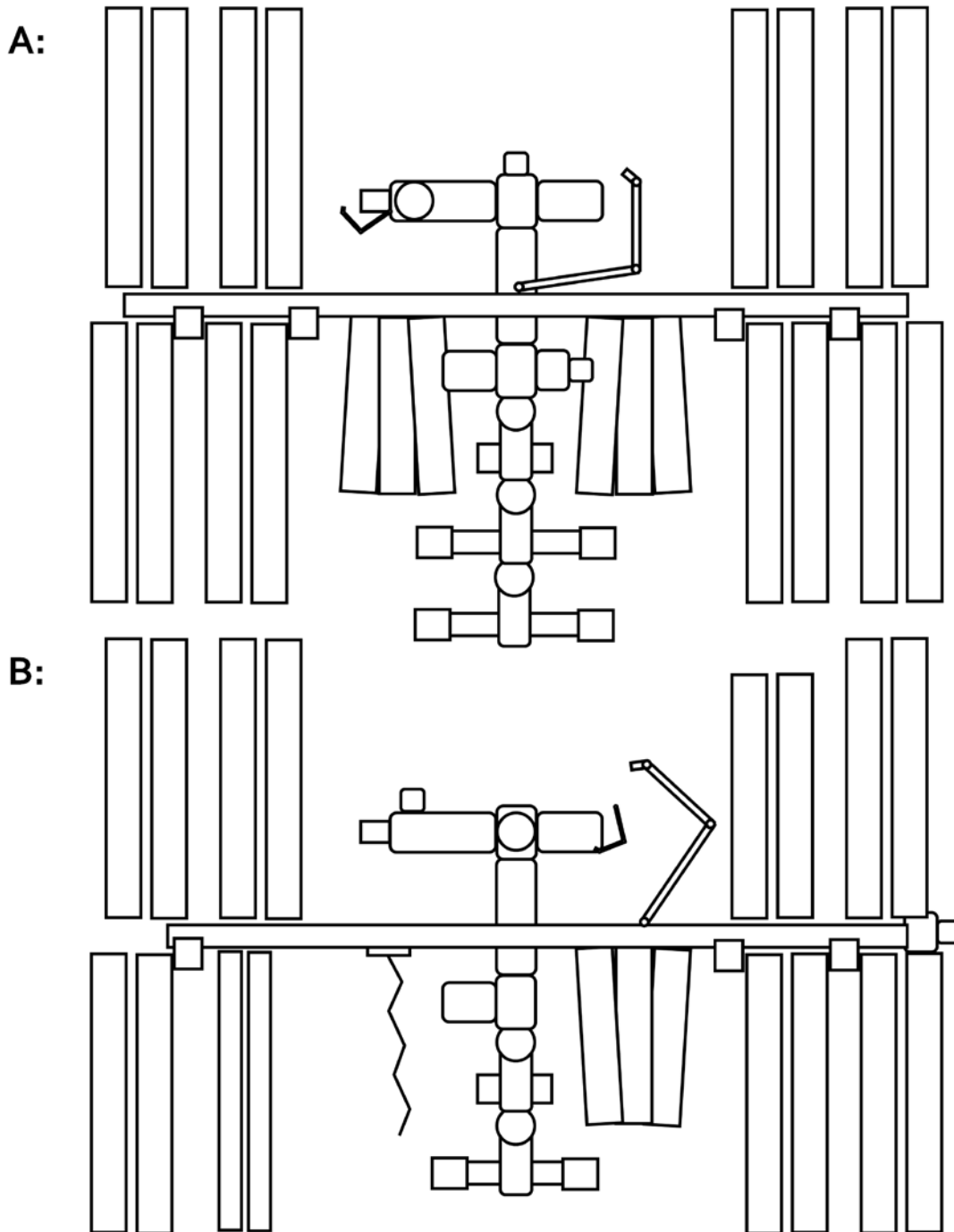

(Answers on page 36)

Packing for a Stay Aboard the Space Station!

Astronaut Yuko is deciding what to take into space. Weight is very important in space travel. Food, water, personal items, and other supplies are needed for the long trip, and their weight all counts against the total weight that the transport spacecraft is able to take up to the Space Station. Yuko can only take up to ten pounds (lb) of personal items with her. Her case weighs two pounds empty, and cannot weigh more than 10 pounds when filled. Help Yuko choose what to take along. Circle the case, and each object you think she should pack in it. Remember to add up the weight as you go, so Yuko doesn't try to pack too much! Multiple solutions are possible!

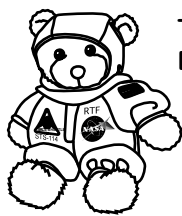

Teddy Bear
1 lb



Cowboy Boots
4 lb



Photo Album
3 lb

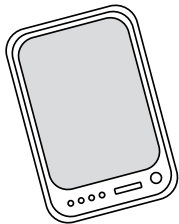

Electronic Tablet
1 lb



Wireless Headphones
1 lb



Giant Chocolate Bar
1 lb

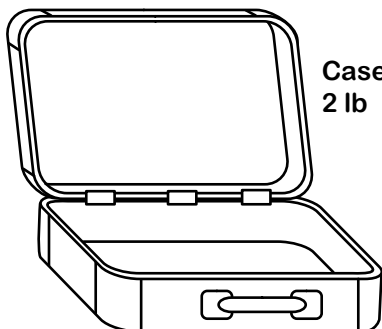

Case
2 lb



Grooming Kit
2 lb

Item packed Weight (lb)

Case

2

Total weight of items: _____
(10 lb maximum)

Now think of what items not already shown here that you would like to take with you if you were given the chance to live and work on the Space Station. How heavy are they? Would you be able to take them with you? What might you have to leave behind?

Space Sudoku!

After a hard day's work, astronauts have time to exercise and relax with some of their favorite activities. Relax with a Sudoku puzzle! Remember, use the numbers 1, 2, 3, and 4 only once each in each row and once in each column.

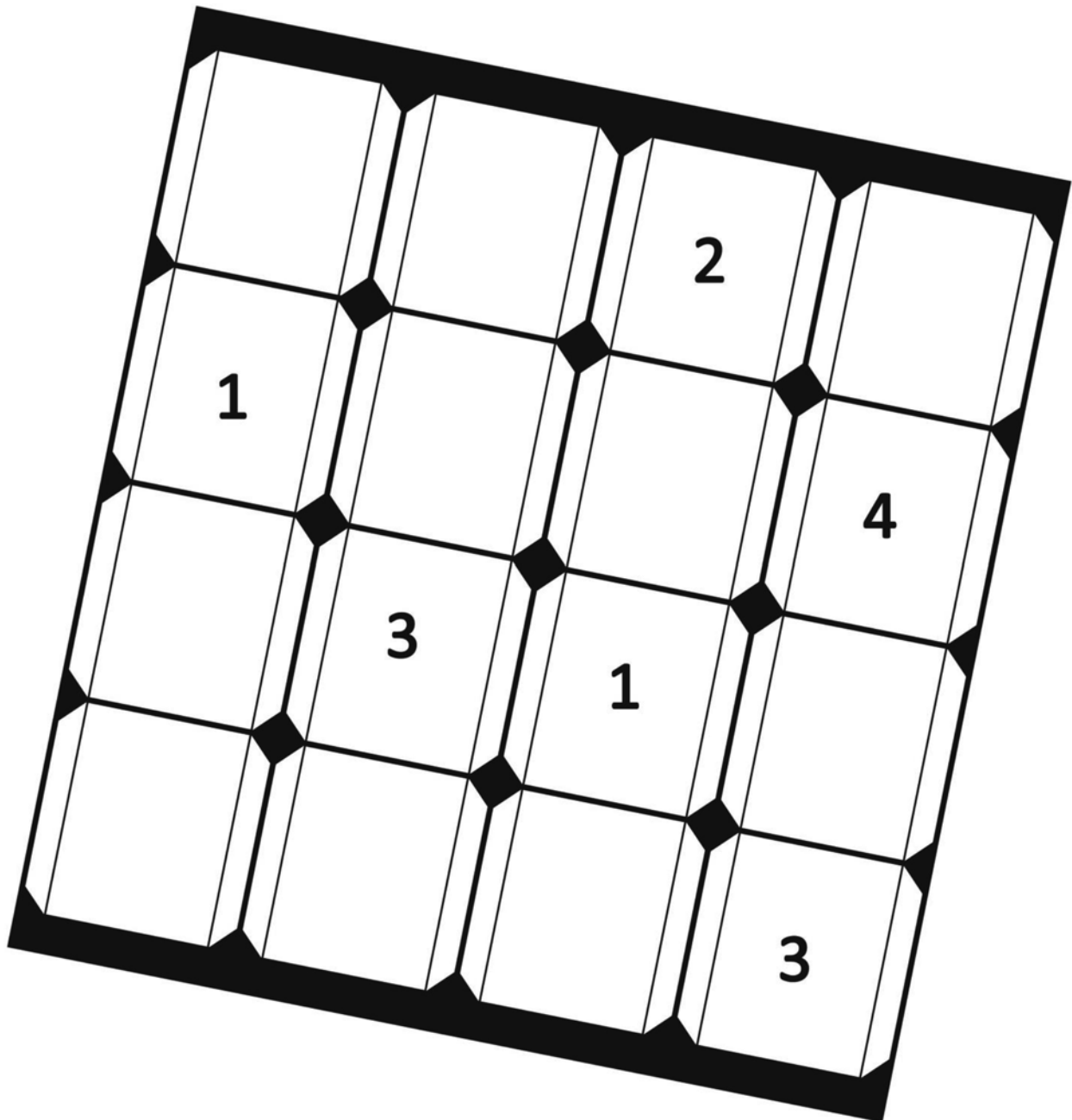

(Solution on page 36)

Fruit Fly Scrambled Segments

You hear that you may be asked to lead a Station experiment involving fruit flies, so you want to make sure you know your insects! Can you name the three segments of an insect's body? Select their names from among those given in the word bank, then write them in the word-boxes provided below.

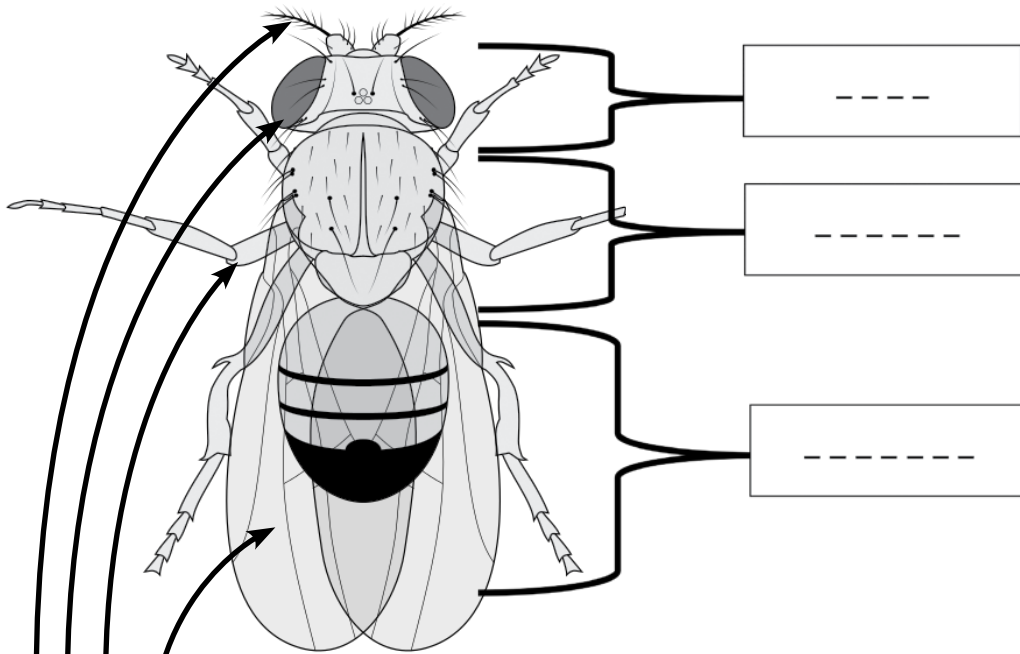

Word Bank

- head
- eyes
- thorax
- belly
- abdomen
- legs
- torso
- dorsal fin
- arms
- antennae
- wings

Now let's see if you can identify some insect parts!
 Below are the scrambled names of four parts of a fruit fly – unscramble them and match them to their correct arrows.
 Hint: these words can also be found in the word bank above!

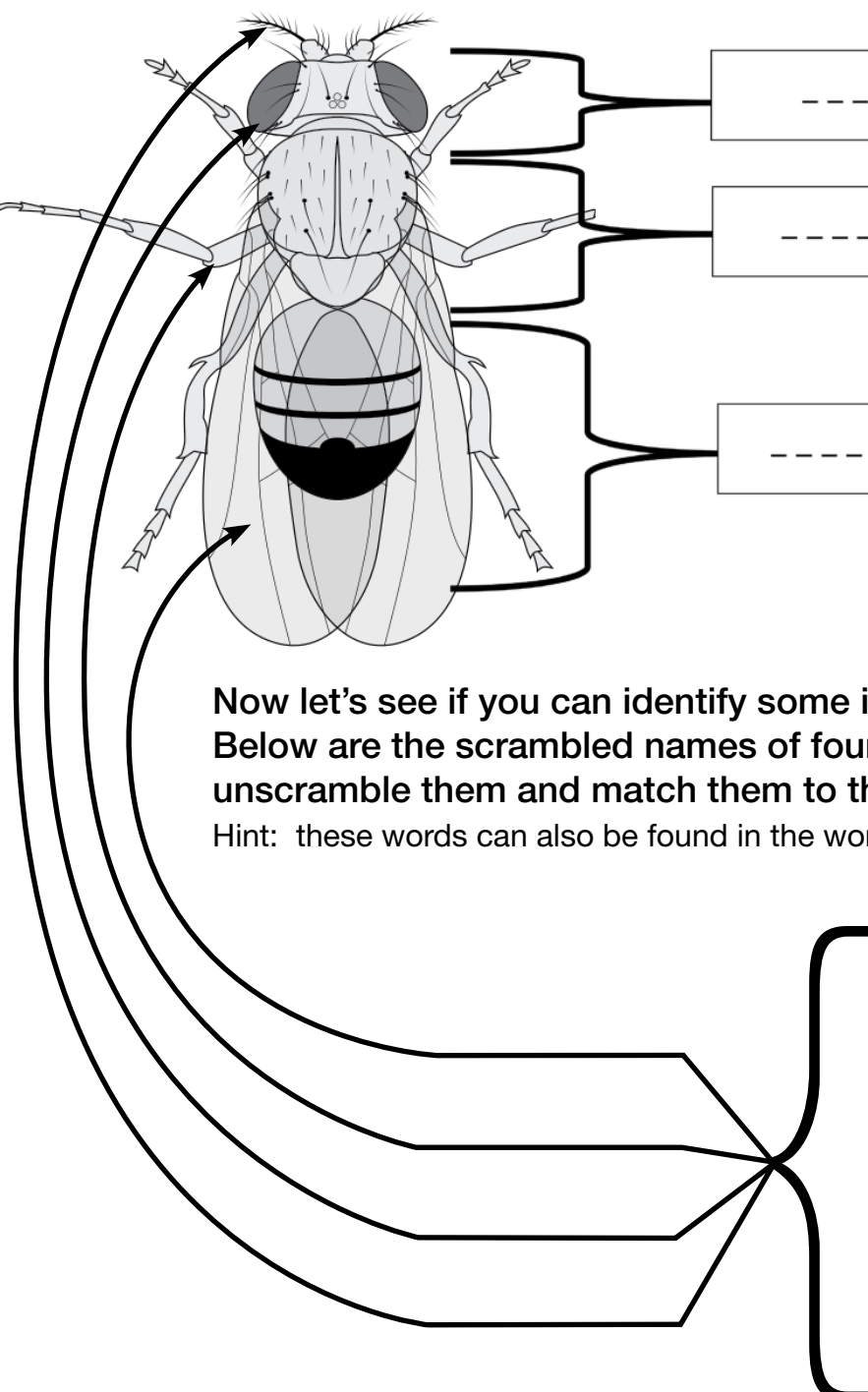

- NEETNAAN

- ISNWG

- YESE

- SEGL

(Solution on page 37)

Finding One's Way Around on the Space Station!

There are many shelves, or 'racks,' in the Destiny Lab on the Space Station. They can be used to hold experiments and research projects. Astronaut Ruby needs to find her way through all of the racks in the Destiny Lab so she can do her research at the rack at the end of the maze. Can you show her how to get to her experiment's rack?

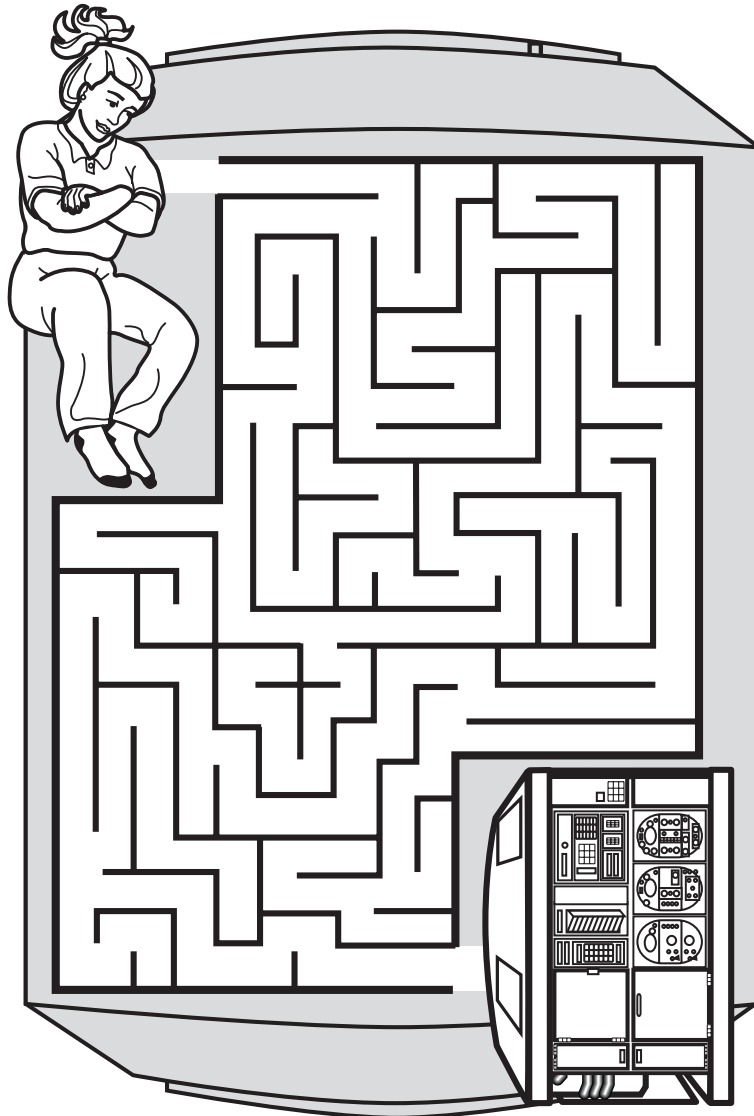

Are you ready to tackle an even bigger challenge? Go to the next page and help a crew member aboard the Space Station get back inside after a space walk!

(Solution on page 37)

a-MAZE-ing Spacewalks!

Sometimes astronauts have to do spacewalks to repair equipment or check on a science experiment outside the Space Station. The Airlock is a special module that lets astronauts in their bulky space suits go outside and come back in again. Help the astronaut get back to the Airlock!

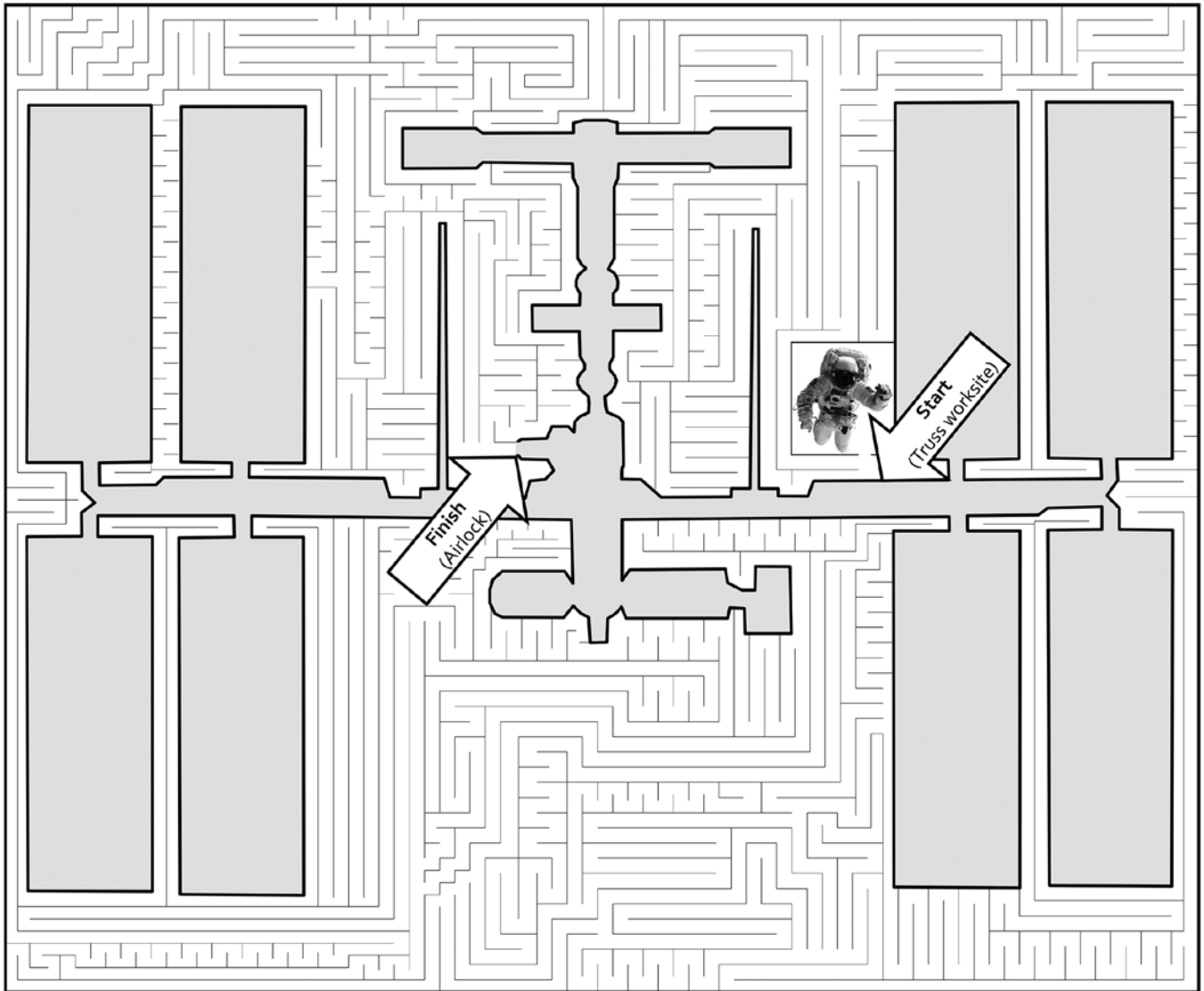

(Solution on page 38)

Space Brain Teasers

Each alphabet letter puzzle below represents a well-known, space-related word or phrase... see if you can figure out what they say! Write each word or phrase on the line provided in its box. Three puzzles have visual clues to help you!

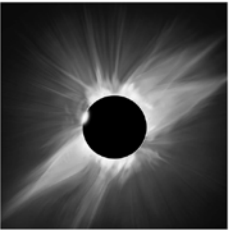
<p style="text-align: right;">- 000:00:09</p> <p>C O U N T</p> <p>_____</p>	<p>S L P O A S C T E</p> <p>_____</p>
<p>MAN THE MOON</p> <p>_____</p>	<p>O T THE R EARTH I B</p>  <p>_____</p>
<p>C CLIPS L I CLIPS P S CLIPS</p>  <p>_____</p>	<p>MILES THE EARTH</p> <p>_____</p>

(Solution on page 39)

Space Station News Word Fun!

Even astronauts goof around sometimes and have fun while on the Space Station. Try this with a friend or several friends: Call out each part of speech (noun, verb, and so on) as it appears in the unfinished news story below, then write the first answer that you hear back in its blank space. Do this until all the blank spaces have been filled in, then read the news story aloud!

NASA is launching a new spacecraft, nicknamed 'The Wild

_____, ' to the Space Station. This spacecraft will carry
NOUN

lots of _____ and _____ for Station's crew to eat,
PLURAL NOUN PLURAL NOUN

and some _____ for them to wear. The spacecraft will launch
PLURAL NOUN

on the new ' _____ ' rocket, the most _____ vehicle
NOUN ADJECTIVE

ever built by the _____ Aerospace Company, located in the
NOUN OR ADJECTIVE

city of _____ . This rocket has revolutionary
ADJECTIVE OR VERB NOUN

new engines that run on ordinary liquid _____ and
NOUN

_____. The first astronauts to fly in this
ADJECTIVE PLURAL NOUN

spacecraft, _____ and _____ , seem excited
NAME OF FRIEND NAME OF ANOTHER FRIEND

about their mission, saying the most challenging thing about it will

be when they have to _____ the _____ ,
VERB NOUN

before their spacewalk to fix Station's aging _____ .
NOUN

Mental Math Mania!

Astronauts, engineers, scientists and budget analysts at NASA need to know their numbers. Test your skills with this math square.

Instructions:

1. Fill in the missing numbers to complete the math square.
2. Use the numbers 1 through 9 to complete the equations.
3. Each number is used only once.
4. Each row is a math equation.
5. Each column is a math equation.

	x		-		3
+		-		x	
	-		x		-69
x		/		-	
	x		+		10
8		0		57	

Hint: Remember that multiplication and division are performed before addition and subtraction.

(Solution on page 39)

Insect Studies!

Many onboard experiments involve insects. Insects' simple genetic codes and short life cycles make them ideal for many research studies onboard the Space Station. Are you familiar with the life cycle stages of such insects as the fruit fly? If so, number the stages shown here in their correct order, by putting the numbers 1 – 5 in the boxes below.



ADULT



PUPA



LARVAE



HATCHING



EGG

Bonus activity

Research fruit flies, then find a picture of fruit flies and color the pictures above to make them look realistic – like real fruit flies!

(Answers on page 39)

Fruit Fly Observations

Here's your chance to be a NASA scientist! Below is half of a simple fruit fly blueprint. Your mission is to complete the other half of the image by drawing the mirror of the image present on the grid.

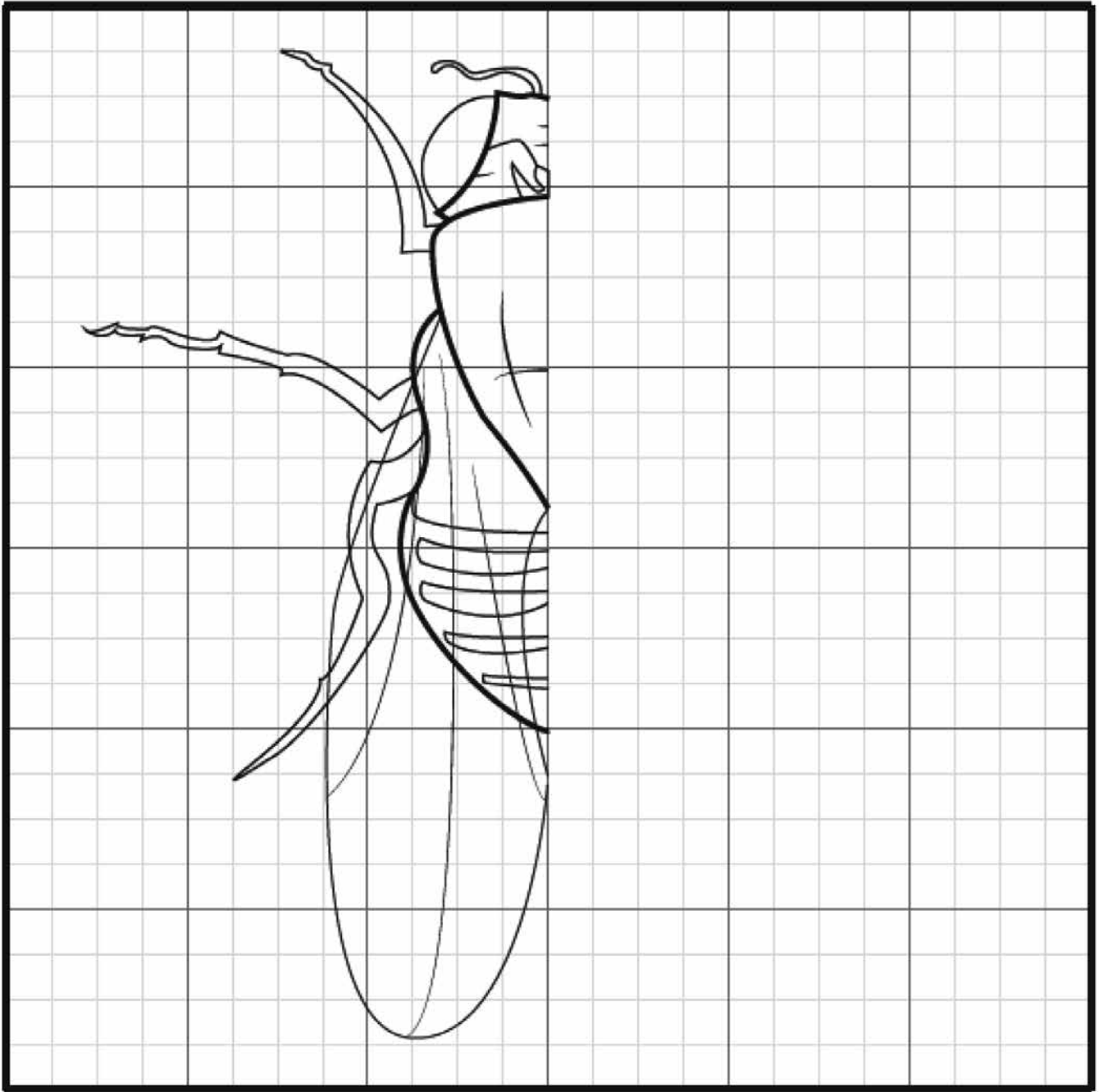

Hint: Count the number of blocks in the grid to make sure your dimensions are correct.

Mission Patch Meanings

Missions, or trips to the Space Station, usually have a patch designed for them that can be worn on shirts, hats, etc., to show the pride that the people involved with them feel in the important work they are doing to improve life on Earth and make it possible to explore space. Check out the sample mission patch below and the meaning of its parts, then think of a mission you would like to work on, choose a name for your mission, and design your very own mission patch for it!

Mission name:
Fruit Fly Lab 01



Mission patch parts or symbols:



Meaning of patch symbols:

Earth, as seen from orbit

The DNA molecule, building-block for all known life forms

The mission acronym (first letter of each word in its name)

The fruit fly – the focus of the mission's experiments

The Space Station, where fruit fly experiments will be done

Draw your mission's patch here – it can be any shape you like!

Your mission's name:

What the symbols in your patch mean:

Bugs Don't Bug Me!

Research what insects can be found where you live, then draw four of them in the boxes below. Don't forget to fill in their names and add 2 facts about each in the spaces provided!

<p>Insect name: _____ Fact 1: _____ Fact 2: _____</p>	<p>Insect name: _____ Fact 1: _____ Fact 2: _____</p>
<p>Insect name: _____ Fact 1: _____ Fact 2: _____</p>	<p>Insect name: _____ Fact 1: _____ Fact 2: _____</p>

Unscramble-gram!

The International Space Station is high-flying platform where scientists conduct research and make discoveries that will help us to understand our world and benefit life on Earth. Want to unravel a mystery of your own?

First, unscramble each of the clue words. Next, copy the letters in the numbered boxes of the clue words to the numbered boxes by the question to solve the mystery.

IERETXEPNM

--	--	--	--	--	--	--	--	--	--	--	--

4

CIGRIRMAVTOY

--	--	--	--	--	--	--	--	--	--	--	--	--	--	--

7 1

FUIRT FYL

--	--	--	--	--	--	--	--	--	--

6

--	--	--	--

RORALBATOY

--	--	--	--	--	--	--	--	--	--	--	--

5

MEGNOE

--	--	--	--	--	--	--

3

MUENIM SYESMT

--	--	--	--	--	--	--	--	--	--	--	--

2 8

What kind of research will be conducted with the fruit fly experiment?

--	--	--	--	--	--	--	--	--	--

1 2 3 4 5 6 7 8

(Answers on page 40)

Design the Next Rocket to Take Astronauts to the International Space Station!

Mix and match the pieces below to design your rocket. Cut out your pieces and paste them together in the picture-box at the right, or simply draw them there. Then, when you've finished building it, name and color your design!

Rocket Engines

(How many of each type will you need?)

Liquid fuel

(Be sure to pick a wide rocket body to hold all the fuel you'll need!)



Solid fuel

(You can pick a narrow rocket body to hold the fuel if you want to!)



Rocket Body

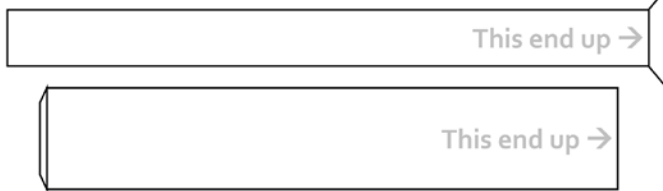

Cargo Compartment

(This is where all the supplies go!)



Crew Compartment

(This is where the astronauts sit!)

Capsule

(You'll need parachutes!)

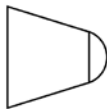

Flying Body

(You'll need wings and wheels!)

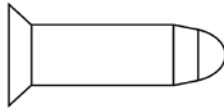

Wings

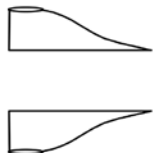

Fins

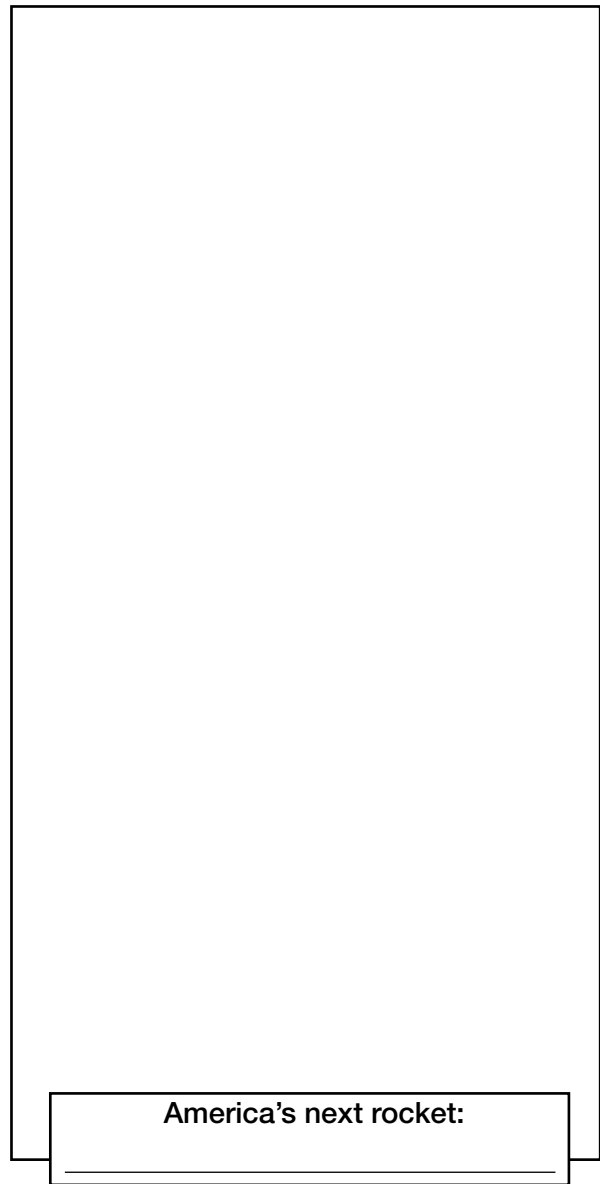
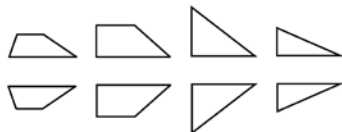

Not sure how this works? See examples on pages 29 and 30!

Wheels or Parachutes

(These aren't seen at launch, but your rocket will need one or the other to land safely!)

- ← Check-mark if you're using a capsule
- Check-mark if you're using wings

Supplying the Space Station

Several different spacecraft, designed and flown by various nations that are part of the international partnership that makes the Space Station possible, make regular visits to the Space Station, delivering astronauts, spare parts, and critical supplies like food, water, and fuel. Some, like Russia's Progress and Soyuz, have been in service many years. Others, like Japan's H-2B Transfer Vehicle (HTV) and Europe's Automated Transfer Vehicle (ATV), were developed especially for the Space Station. Others still, like the United States's Dragon and Cygnus, are brand new. One, the Space Shuttle, has been retired after serving for many years as the Station's main construction and supply vehicle.

Unscramble the mixed up letters below to identify the many spacecraft that have kept the Space Station supplied, then do the same for the names of the nations or group of nations that provided them. Lastly, draw lines to connect each spacecraft to its provider!

(Hint: Some providers have produced more than one spacecraft!)

Spacecraft

UGCYSN

SEGRROSP

SSCAPULTETHE

2HABTHECELFVIRNE

- - - - -

NOGRDA

YOZSU

VCIAALTEFSRHUTEENMOTADR

Providers

USRSAI

TTANDIUEESTS

ORUEEP

AAJNP

(Answers on page 40)

Fun Facts

Here are some more things about our International Space Station you might not have known... tell your friends! Amaze your family!

Did you know...

- Space Station's living space is about the size of a 6-bedroom house
- Weightless Station astronauts sleep in any direction with no bed, just a sleeping bag strapped to a wall so they don't float around
- The Station's weightless environment means toilets have to be specially designed to work like vacuum cleaners and suck wastes in, recycle most of the water, and seal the rest in plastic bags
- Weightlessness also makes showering a challenge – water droplets can float anywhere and really damage computers, machines, and so on – so astronauts rub water and soap on and sponge it off again
- There are about 8 miles of wiring in the Station's electrical system
- Over 100,000 people around the world worked together to make the Space Station possible
- Astronauts have to exercise hard for at least 2 hours every day to keep their muscles and bones from getting too soft, which is what they would otherwise do without having gravity to work against
- Over 50 computers keep the Station's systems working
- Astronauts, when they're enjoying what little free time they get, often spend it reading, listening to music, emailing or otherwise keeping in touch with their families and friends on Earth, or taking pictures of Earth and space out the windows
- Research on Station continues to make discoveries important to us here on Earth including, recently, a possible vaccine for salmonella, a food-poisoning illness that is especially dangerous to children

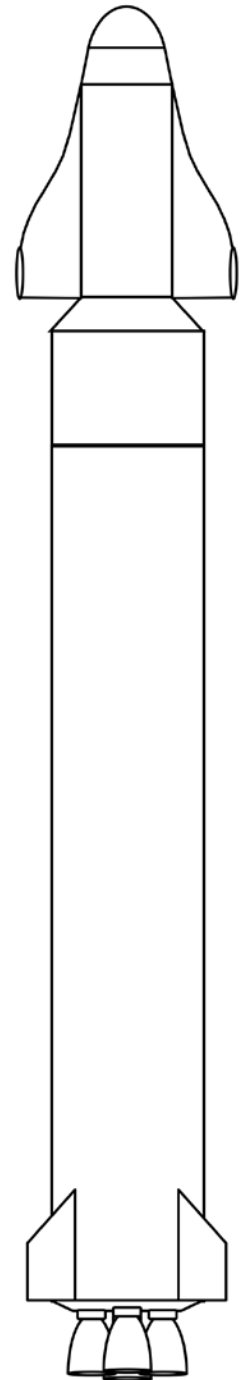

Example
rocket 1
(p. 27)

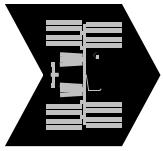

Want to learn more?

Check out some of these awesome websites!

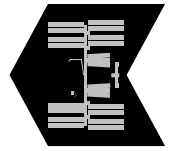

For Space Station viewing times (and where to look to see it) go to:

<http://spaceflight.nasa.gov/realdata/sightings/index.html>

To learn more about research being done on the Space Station, try:

http://www.nasa.gov/mission_pages/station/research/index.html

http://www.nasa.gov/mission_pages/station/research/ops/research_student.html

Space agencies' websites
(most of these are especially for kids!):

NASA (United States):

<http://kids.earth.nasa.gov/>

<http://www.nasa.gov/audience/forkids/kidsclub/flash/index.html>

<http://quest.nasa.gov/index.html>

<http://www.nasa.gov/audience/forstudents/index.html>

<http://solarsystem.nasa.gov/kids/index.cfm>

<http://spaceplace.nasa.gov///redirected/>

CSA (Canada):

<http://www.asc-csa.gc.ca/eng/iss/default.asp>

ESA (Europe):

http://www.esa.int/esaKIDSen/SEMZXJWJD1E_LifeinSpace_0.html

JAXA (Japan):

<http://iss.jaxa.jp/kids/en/index.html>

ROSCOSMOS (Russia):

<http://www.en.federalspace.ru/>

We hope you had fun learning about the amazing International Space Station and that you'll visit us at NASA online real soon!

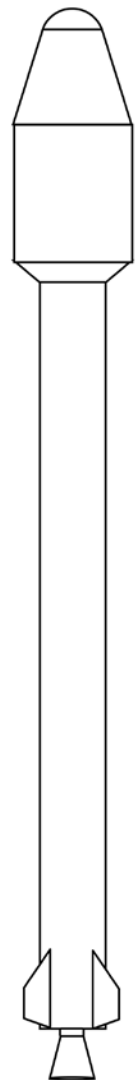

Example rocket 2
(p. 27)



Answer Key

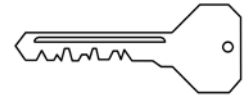

International Space Station Activity Book

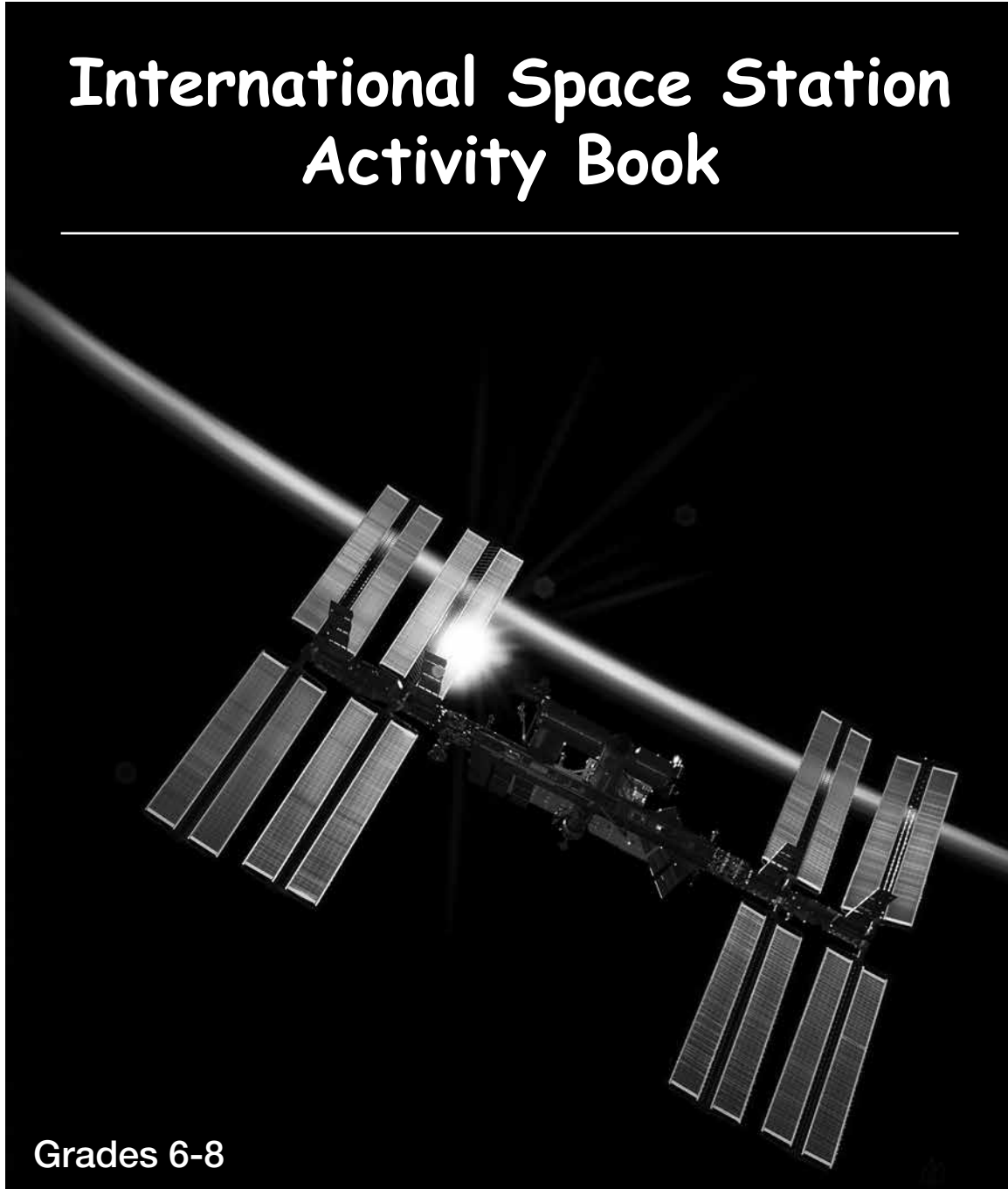

Grades 6-8

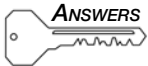

Space Symbols and Agency Acronyms

NATIONAL AERONAUTICS & SPACE ADMINISTRATION

October 1, 2018 marks NASA's 60th anniversary!

The States of NASA

- | | | |
|----------------|------------|--------------|
| 1) California | 4) Alabama | 7) Virginia |
| 2) Texas | 5) Florida | 8) Maryland |
| 3) Mississippi | 6) Ohio | 9) Louisiana |

Bonus: District of Columbia

Did You Know...?

1. C: Your rectangle would be as big as a football field plus end zones.
2. D: The Space Station weighs close to 1 million pounds. Even though it is in space, it isn't weightless because it is still close enough to Earth to feel nearly the full effects of its gravity. Astronauts feel weightless in orbit because the Station's forward speed is fast enough that its path matches the Earth's curvature, even though it is in constant free-fall – a condition that feels weightless because everything in the Station is falling together at the same rate. Cool, huh?
3. B: At its average altitude of about 250 miles, the Space Station needs to go about 17500 miles per hour to stay in orbit – and it sure does!
4. A: Astronauts on board the Space Station go around the Earth once every 90 minutes (an hour-and-a-half) or so, and therefore see a sunrise (and a sunset!) every 90 minutes as well. While it is true that the sun is always shining in space, the fact that the Station is going around the Earth means that its view of the sun is blocked by the Earth during part of each orbit, so each trip around the Earth has a daytime and a night-time.
5. D: The first piece of the Space Station was launched by Russia in 1998.
6. A: In a seemingly 'weightless' environment such as the Space Station has, the spine relaxes, so you – as an on-board guest – would 'grow' taller! (You'd 'shrink' back to your usual height once back on Earth – sorry!)

International Space Station Parts

- 6 **Solar arrays** (8 pairs) make electricity from sunlight and store it in batteries
- 7 **Truss** (big beam) holds solar arrays, radiators, and often the big robotic arm
- 2 **Radiators** get rid of heat from solar arrays and modules to keep things cool
- 9 Canada's big **robotic arm** moves people, parts and even spacecraft around
- 8 **Modules** (big soup can shaped parts) are where the astronauts live and work
- 3 **Soyuz** and **Progress** (Russian spacecraft) bring people, supplies and fuel
- 5 **ATV** (European spacecraft) is designed to bring supplies and fuel
- 4 **HTV** (Japanese spacecraft) is designed to bring supplies and spare parts
- 1 **Dragon, Cygnus** (American spacecraft); designed to bring people, parts, and/or supplies

Welcome to the Space Station Word Search!

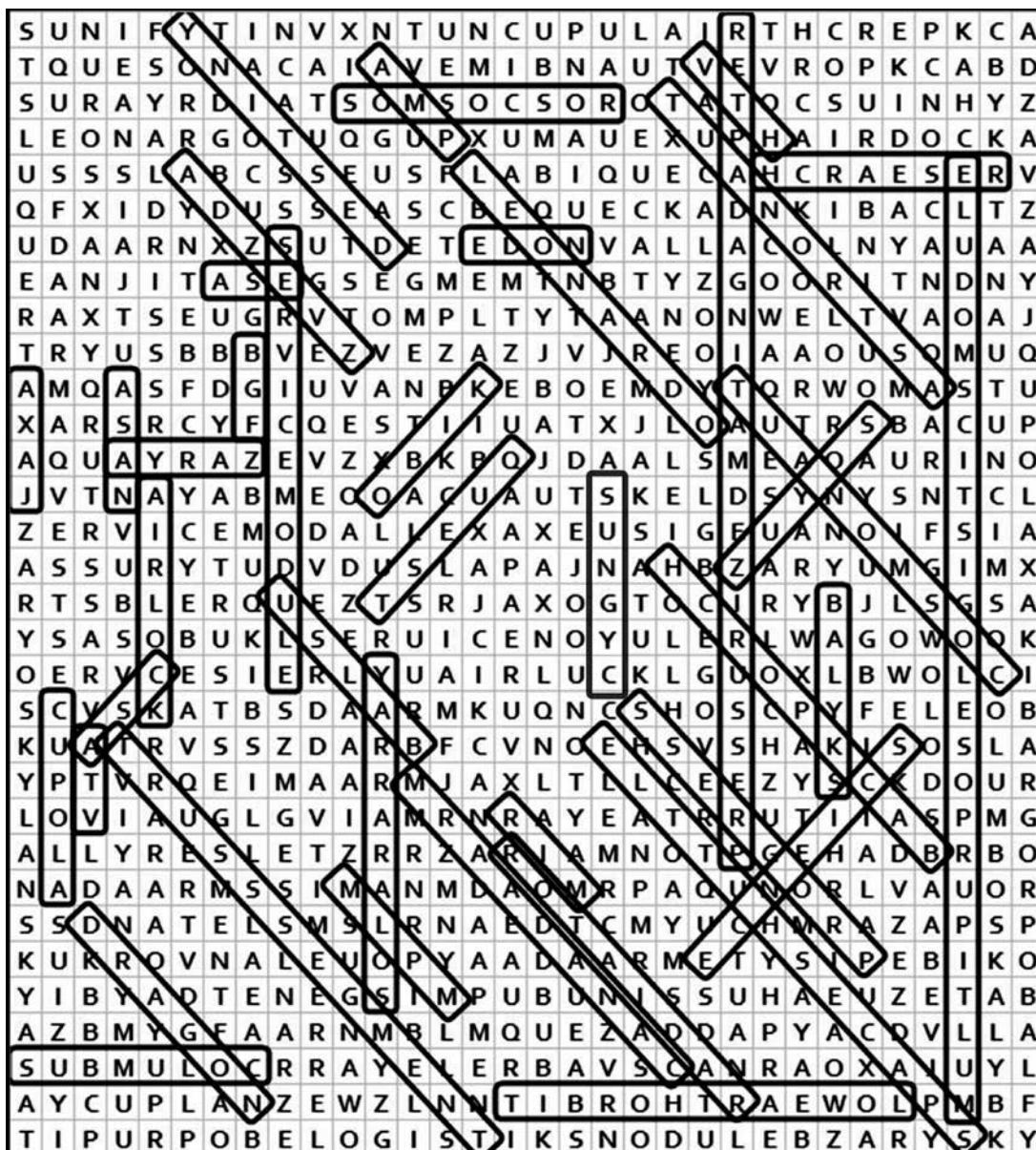

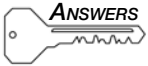

Letter Shuffle

These are some sample words you could make from the letters in "SPACE STATION."
How many more were you able to find?

space spaces pace paces an in on ion ace aces pact pacts cap
no tips spit spat sate noise noises ant pant tin it is pants so
iota ape cop ten tip snit capstan insect insects cessation
capes act past cat tine tines stein nastiest nosiest ants saps
pin pane cane sap pasts pasta pastas pat pate pates peat
tap nap nest nose spates teases tease eat eats seat seats
note pan snaps toe toes sot sat pita pitas pies nose noses at
pint pints spice spices state states net ten tent nets tens top
tents test tests potent posies posts post pit spite spites one
tops stop stops pones ponies cine scones scone antes stint its
ones tone tones stone stones stoniest toniest not snot sots
tots tot tote totes scot scat scats cast caste casts castes
sea seas cost costs notes capes cape capo point points paint
paints cone con cons cones icon icons ion ions peon peons pen
pin pinto pins spin spins spans span contest contests pinto pi
posit posits spate pent coin coins cite cites tact intact nip nips
snip snips snap snaps pas pa pass apt opt inept action actions
nape napes tape tapes apes station stations coat coats ante
cote cotes sates caisson pit cant scantiest scant cants apace

What's in a Name?



Draw the International Space Station!

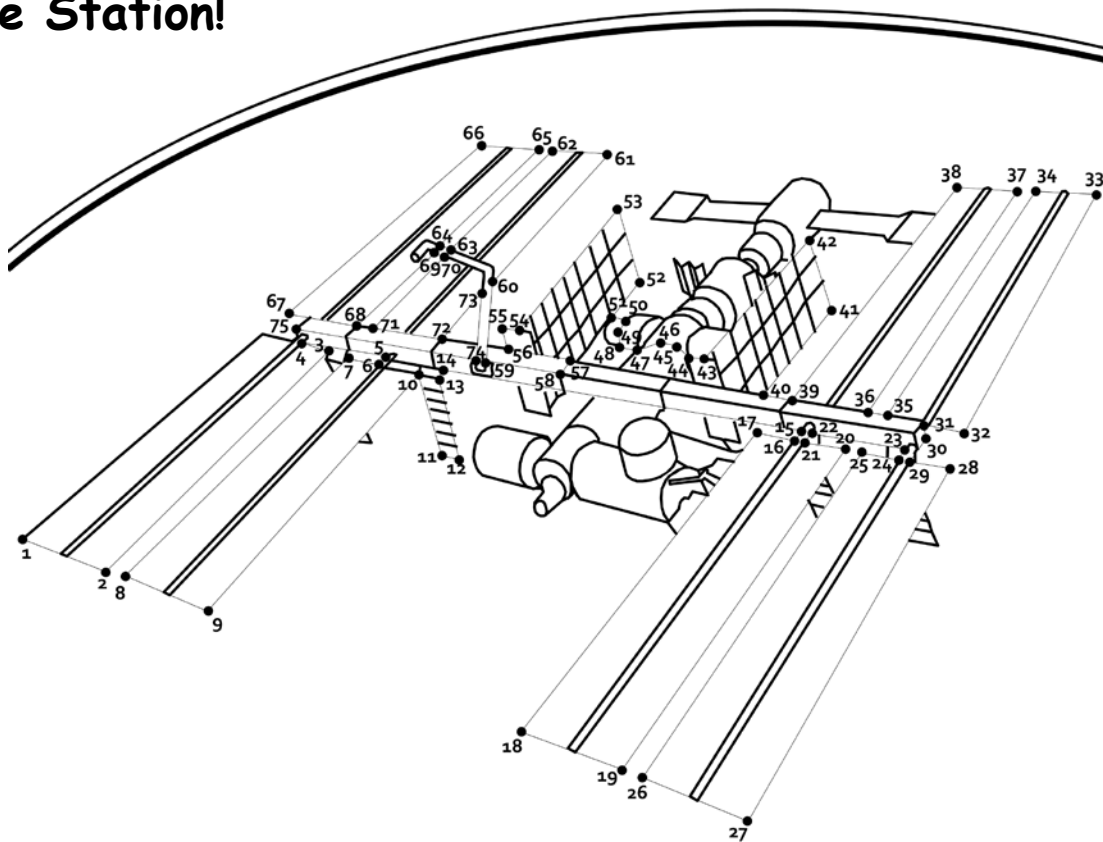

What's Different?

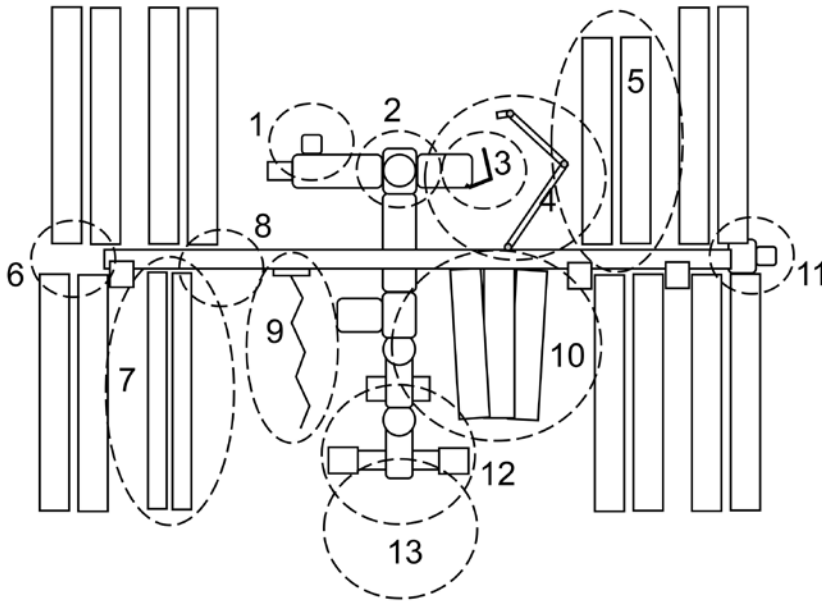

1. Docking port moved to Kibo
2. Kibo's storage module moved to the Node
3. Japanese robotic arm moved to the Columbus module
4. Canadarm2 moved to the truss
5. Solar array got shorter
6. Truss got shorter
7. Solar array got skinnier
8. Radiator is missing
9. Radiator rotated to be edge-on
10. Radiator is on backwards
11. Airlock moved to end of truss
12. Service Module's solar array 'wings' got shorter
13. Progress supply ship is gone

Space Sudoku!

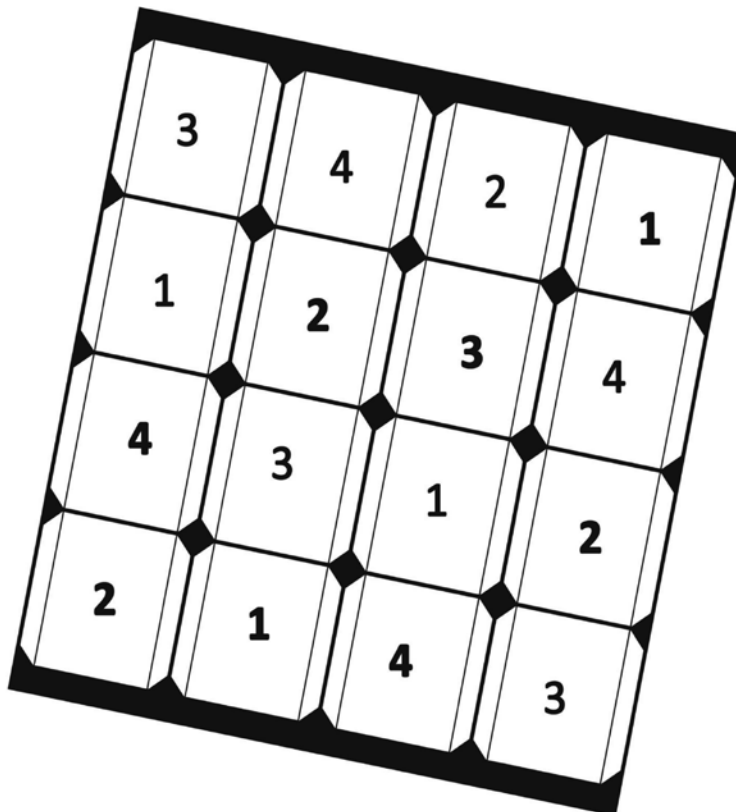

Fruit Fly Scrambled Segments

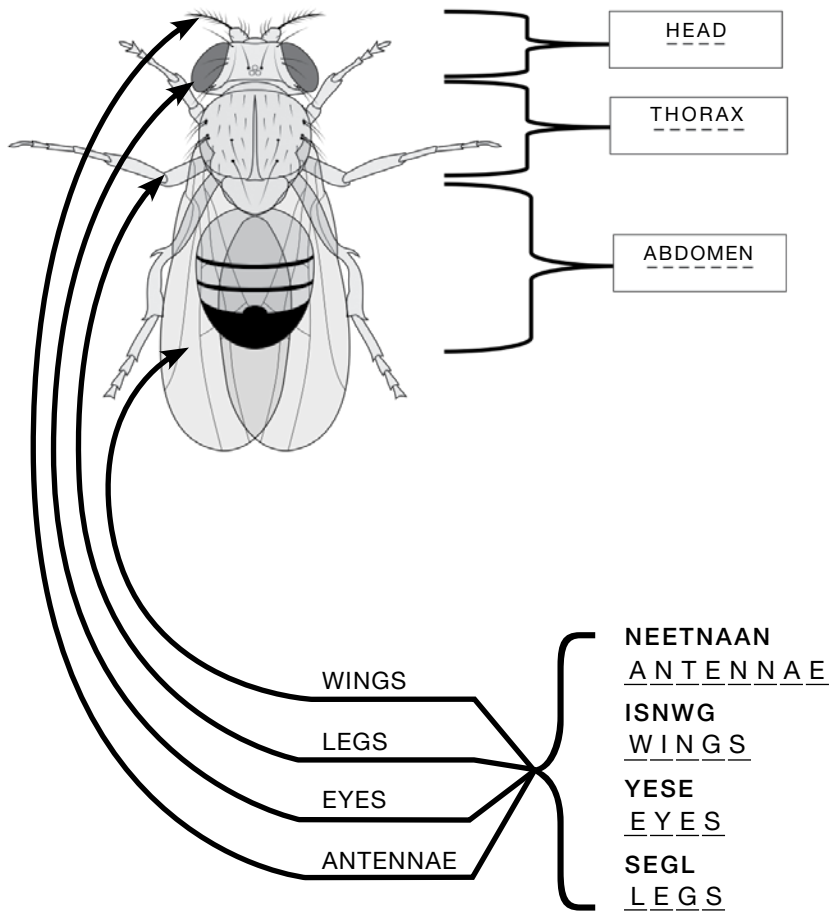

Finding One's Way Around on the Space Station!

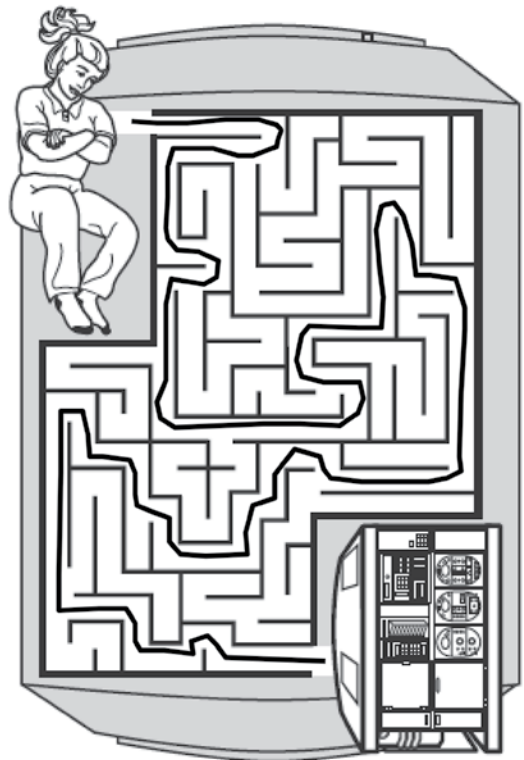

a-MAZE-ing Spacewalks!

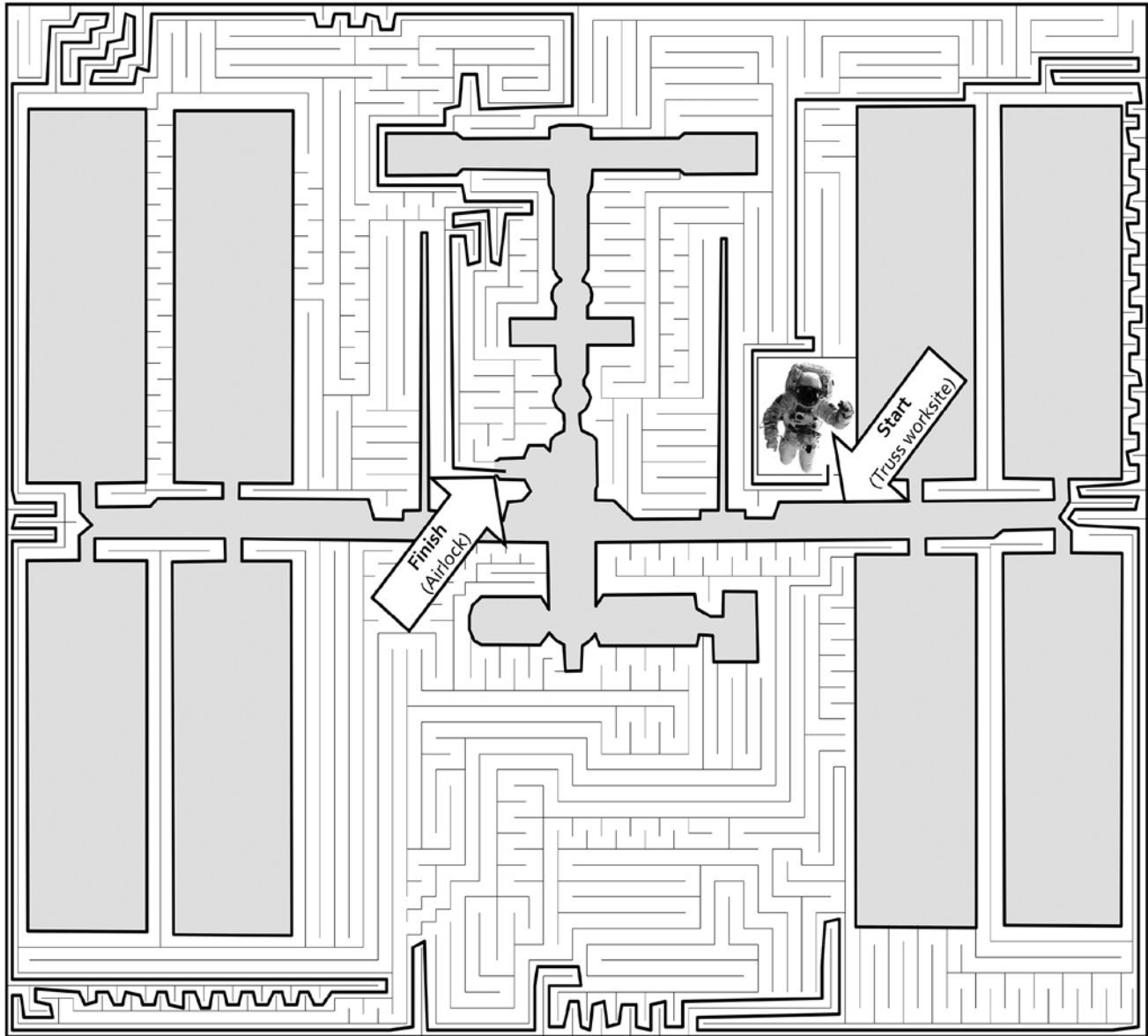

There are several paths through the maze – above is the quickest one... or is it? Can you find the other paths? Can you find one that is shorter?

Space Brain Teasers

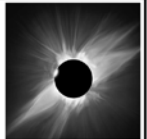
<p>C O U N T</p> <p>- 000:00:09</p> <p><u>COUNTDOWN</u></p>	<p>S L P O A S C T E</p> <p><u>LOST IN SPACE</u></p>
<p>MAN THE MOON</p> <p><u>MAN ON THE MOON</u></p>	<p>O T THE R E A R T H I B</p>  <p><u>ORBIT AROUND THE EARTH</u></p>
<p>C CLIPS L I CLIPS P S CLIPS</p>  <p><u>ECLIPSE</u></p>	<p>MILES THE EARTH</p> <p><u>MILES ABOVE THE EARTH</u></p>

Mental Math Mania!

5	x	2	-	7	3
+		-		x	
3	-	8	x	9	-69
x		/		-	
1	x	4	+	6	10
8	0	57			

Insect Studies!

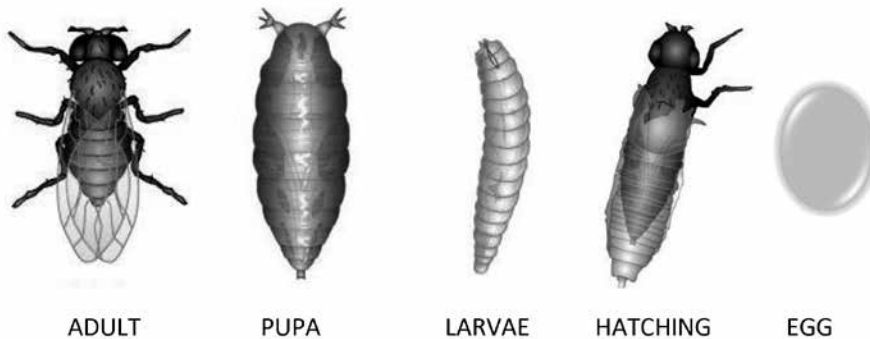

5 3 2 4 1

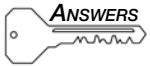

Unscramble-gram!

E X P E R I M E N T
4

M I C R O G R A V I T Y
7 1

F R U I T F L Y
6

L A B O R A T O R Y
5

G E N O M E
3

I M M U N E S Y S T E M
2 8

G E N E T I C S
1 2 3 4 5 6 7 8

Supplying the Space Station

Spacecraft

UGCYSN
SEGRROSP
SSCAPULTETHE
2HABTHECELFVIRNE
NOGRDA
YOZSU
VCIAALTEFSRHUTEENMOTADR

CYGNUS ←
PROGRESS ←
SPACE SHUTTLE ←
H-2B TRANSFER VEHICLE ←
DRAGON ←
SOYUZ ←
AUTOMATED TRANSFER VEHICLE ←

Providers

USRSAI
TTANDIUEESTS
ORUEEP
AAJNP

RUSSIA
UNITED STATES
EUROPE
JAPAN

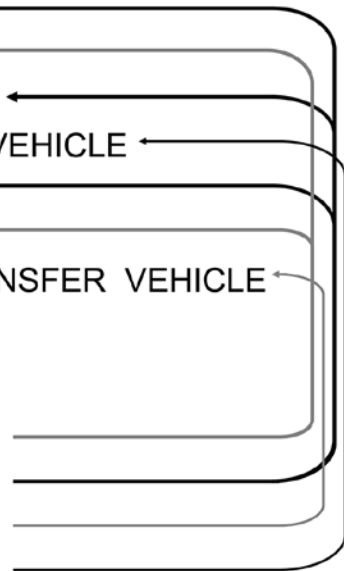

Back Cover

Here's the solution to back cover puzzle – and then some! Did you find the Space Station? As a secret bonus, the puzzle features another Earth neighbor – Mars! If while searching for the Space Station you noticed that red blob & wondered about it, give yourself an extra pat on the back – noticing what you weren't looking for is how discoveries are made!

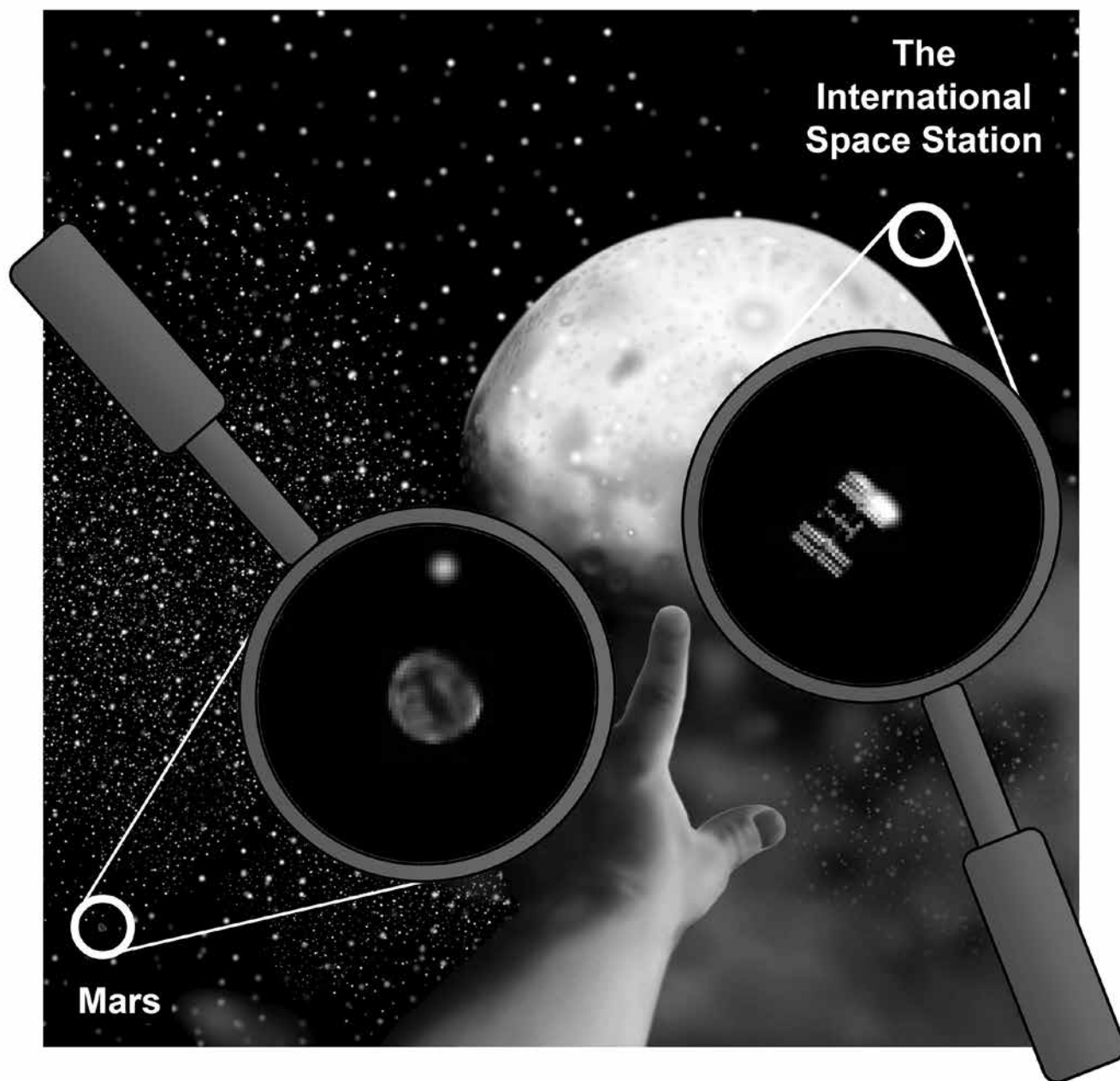

Some nights the Moon and stars seem so big and close that it feels like you could almost reach out and touch them, don't they? Now there's a new star in the sky – the Space Station – and it will help us reach the Moon, Mars, and maybe even the stars someday! Can you find it in the picture below? Look carefully!



(Answer on page 41)