



National Aeronautics and  
Space Administration

Volume 1  
Executive Summary and  
Chapters 1 through 8

July 2005

# Final Environmental Impact Statement for the New Horizons Mission

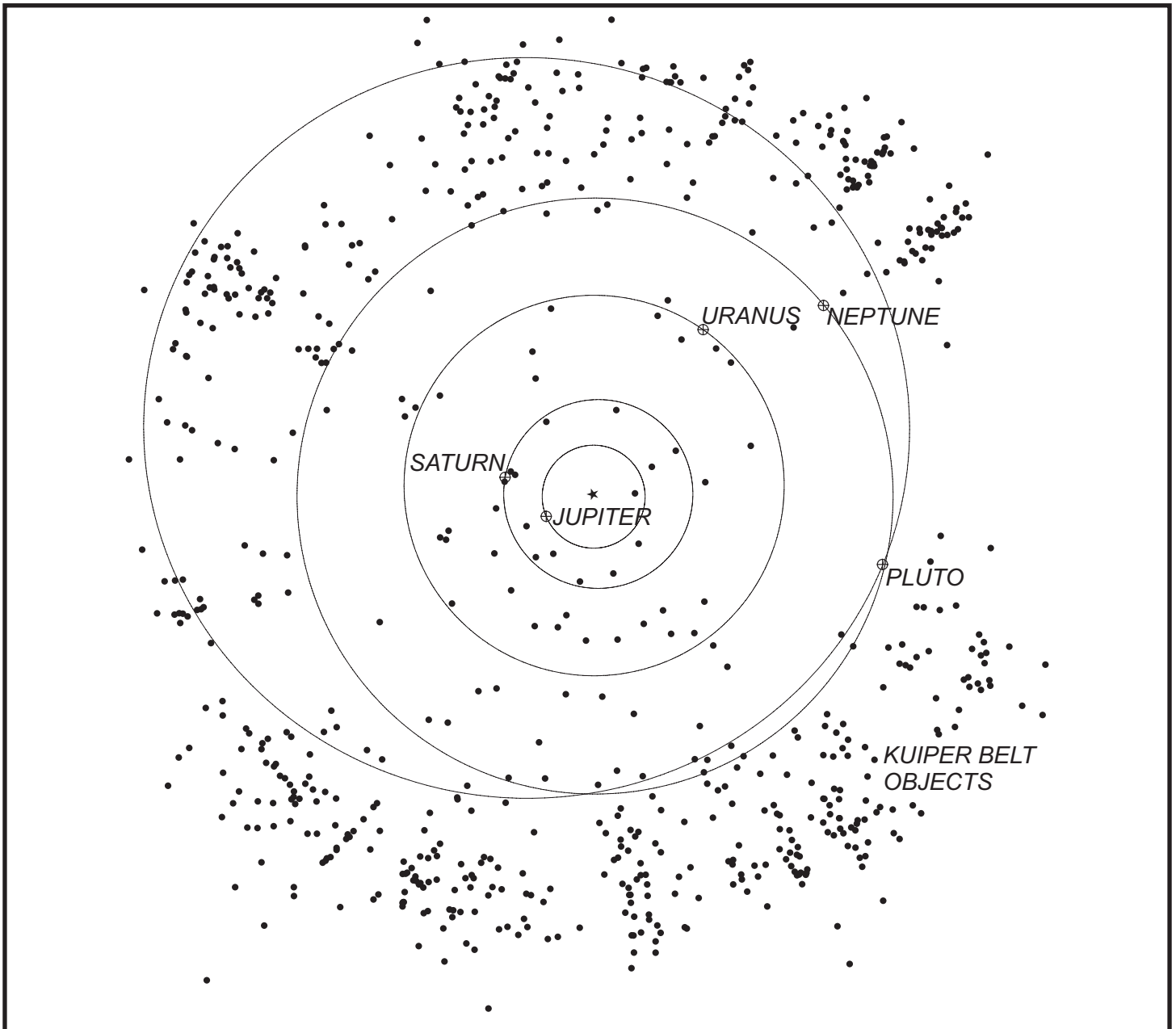

**Cover graphic, *Map of the Outer Solar System*, courtesy of  
Gareth V. Williams, Harvard-Smithsonian Center for Astrophysics.  
Positions of the planets and Kuiper Belt Objects are shown as of June 2002.**

# **FINAL ENVIRONMENTAL IMPACT STATEMENT FOR THE NEW HORIZONS MISSION**

## **VOLUME 1 EXECUTIVE SUMMARY AND CHAPTERS 1 THROUGH 8**

**Science Mission Directorate  
National Aeronautics and Space Administration  
Washington, DC 20546**

**July 2005**

This page intentionally left blank.

# FINAL ENVIRONMENTAL IMPACT STATEMENT FOR THE NEW HORIZONS MISSION

## ABSTRACT

LEAD AGENCY: National Aeronautics and Space Administration  
Washington, DC 20546

COOPERATING AGENCY: U.S. Department of Energy  
Washington, DC 20585

POINT OF CONTACT  
FOR INFORMATION: Kurt Lindstrom  
Mission and Systems Management Division  
Science Mission Directorate  
NASA Headquarters  
Washington, DC 20546  
(202) 358-1588

DATE: July 2005

This Final Environmental Impact Statement (FEIS) has been prepared by the National Aeronautics and Space Administration (NASA) in accordance with the National Environmental Policy Act (NEPA), as amended, to assist in the decision making process for the New Horizons mission to Pluto.

The Proposed Action addressed in this FEIS is to continue preparations for and implement the New Horizons mission to explore Pluto and potentially the recently-discovered Kuiper Belt. The New Horizons spacecraft would be launched on an expendable launch vehicle in January – February 2006 from Cape Canaveral Air Force Station, Florida. With a launch in mid January 2006, the spacecraft would arrive at Pluto in 2015 to conduct scientific investigations of Pluto and its moon, Charon, as it flies past each body. After completing its investigations of Pluto and Charon, the spacecraft could continue into the Kuiper Belt on an extended mission to investigate one or more of the objects within the Kuiper Belt. The New Horizons mission would measure the fundamental physical and chemical properties of the Pluto-Charon system, and would make the first close observations of Kuiper Belt Objects, which are likely remnants of, and hold clues to, the early formation of the solar system.

This FEIS presents descriptions of the proposed New Horizons mission, spacecraft, and launch vehicle; an overview of the affected environment at and near the launch site; and the potential environmental consequences associated with the Proposed Action and the No Action Alternative.

This page intentionally left blank

## EXECUTIVE SUMMARY

This Final Environmental Impact Statement (FEIS) for the New Horizons mission has been prepared in accordance with the National Environmental Policy Act of 1969 (NEPA), as amended (42 U.S.C. 4321 et seq.); Executive Order 12114, *Environmental Effects Abroad of Major Federal Actions*; the Council on Environmental Quality Regulations for Implementing the Procedural Provisions of NEPA (40 CFR parts 1500–1508); and the National Aeronautics and Space Administration's (NASA's) policy and procedures (14 CFR part 1216). The purpose of this FEIS is to assist in the decisionmaking process concerning the Proposed Action and the No Action Alternative for the New Horizons mission to Pluto.

The New Horizons mission is planned for launch in January – February 2006 from Cape Canaveral Air Force Station (CCAFS), Florida, on an expendable launch vehicle. With a launch in mid January 2006, the New Horizons spacecraft would receive a gravity assist from Jupiter in February 2007 and would arrive at Pluto as early as 2015. The spacecraft would conduct scientific investigations of Pluto and its moon, Charon, as it flies past these bodies. The spacecraft may then continue on an extended mission into the Kuiper Belt, where it would investigate one or more of the objects found there. The spacecraft would require electrical power for normal spacecraft operations and to operate the science instruments. One radioisotope thermoelectric generator (RTG) containing plutonium dioxide would be used for this purpose.

### PURPOSE AND NEED FOR ACTION

The purpose of the action addressed in this FEIS is to further our knowledge of Pluto, the outermost known planet of our solar system, and its moon, Charon, and the Kuiper Belt. The goal of the New Horizons mission would be to measure the fundamental physical and chemical properties of Pluto and Charon. Specifically, the New Horizons mission would acquire data to address the following primary scientific objectives.

- Characterize the global geology and morphology of Pluto and Charon.
- Map the surface compositions of Pluto and Charon.
- Characterize the neutral (uncharged) atmosphere of Pluto and its rate of escape.

After the Pluto-Charon flyby and data playback is complete, the spacecraft could continue on an extended mission to encounter one or more objects within the Kuiper Belt. The remote science instrumentation planned for Pluto and Charon could also be used for investigations of the Kuiper Belt Objects (KBO).

Pluto is the only major body within our solar system that has not yet been visited by spacecraft. Many of the questions posed about Pluto and Charon can only be addressed by a spacecraft mission that brings advanced instruments close to the two bodies. Scientific knowledge of all other planets and their moons, and thus understanding of the nature of the solar system, has been increased enormously through visits by spacecraft.

The science to be performed at Pluto and Charon is time-critical because of long-term seasonal changes in the surfaces and atmospheres of both bodies. The objectives of surface mapping and surface composition mapping would be significantly compromised as Pluto and Charon recede from the Sun and their polar regions become increasingly hidden in shadow. Furthermore, as Pluto recedes from the Sun, substantial decline, if not complete collapse, of its atmosphere is widely anticipated.

The recent discovery of many objects beyond Neptune in the Kuiper Belt has opened another dimension for a mission of exploration. KBOs, in stable and well-defined orbits that have never taken them close to the Sun, are likely to be remnants of solar system formation and may hold clues to the birth of the planets. Knowledge gained from close examination of objects in the Kuiper Belt would be of great value in developing theoretical models of the evolution and destiny of the solar system.

## **ALTERNATIVES EVALUATED**

This FEIS for the New Horizons mission evaluates the Proposed Action and the No Action Alternative.

- Proposed Action (NASA's Preferred Alternative) — NASA proposes to continue preparations for and implement the New Horizons mission to Pluto and its moon Charon, and the Kuiper Belt. NASA proposes to launch the New Horizons spacecraft from CCAFS, Florida, in January – February 2006 on board an Atlas V 551 expendable launch vehicle onto a trajectory towards Pluto. The New Horizons spacecraft would arrive at Pluto in 2015. The New Horizons spacecraft would remotely gather scientific data on Pluto, Charon, and one or more objects within the Kuiper Belt. A backup launch opportunity may exist in February 2007.
- No Action Alternative — Under this alternative, NASA would discontinue preparations for and not implement the New Horizons mission. There would be no reconnaissance of Pluto, Charon and any KBOs during the timeframe of the Proposed Action. Potential science and data collection from the proposed mission would not be realized.

Alternatives to the Proposed Action that were considered but were not evaluated further include alternate power systems and alternate trajectories.

## **ENVIRONMENTAL IMPACTS OF THE PROPOSED ACTION AND THE NO ACTION ALTERNATIVE**

For the New Horizons mission, the potentially affected environment includes the areas on or near the vicinity of the Atlas V launch site at CCAFS in Florida, and the global environment. The potential environmental consequences of the Atlas V launch vehicle have been addressed in prior U.S. Air Force (USAF) and NASA environmental documents, and are summarized below.

### **Environmental Impacts of the Mission**

The environmental impacts of a normal launch of the New Horizons spacecraft for the Proposed Action would be associated principally with the exhaust emissions from the



Atlas V. These effects would include short-term impacts on air quality from the exhaust cloud at and near the launch pad, and the potential for acidic deposition on the vegetation and surface water bodies at and near the launch complex from the vehicle's solid rocket boosters. These effects would be transient and there would be no long-term impacts to the environment. Some short-term ozone degradation would occur along the flight path of the Atlas V as the vehicle passes through the stratosphere and deposits ozone-depleting chemicals (primarily hydrogen chloride) from its solid rocket boosters. These effects would be transient and no long-term impacts would be expected to the ozone layer (USAF 2000).

There would be no environmental impacts associated with the No Action Alternative.

### **Environmental Impacts of Potential Nonradiological Launch Accidents**

Nonradiological accidents could occur during preparation for and launch of the New Horizons spacecraft at CCAFS. The two nonradiological accidents of principal concern would be a liquid propellant spill during fueling operations and a launch vehicle failure. Propellant spills or releases would be minimized through remotely operated actions that close applicable valves and safe the propellant loading system. Propellant loading would occur only shortly before launch, further minimizing the potential for accidents.

Range Safety at CCAFS uses models to predict launch hazards to the public and on-site personnel prior to a launch. These models calculate the risk of injury resulting from exposure to potentially toxic exhaust gases from normal launches, and from exposure to potentially toxic concentrations, blast overpressure or debris due to a failed launch. The launch could be postponed if the predicted collective risk of injury from exposure to toxic gases, blast overpressure or debris exceeds acceptable limits (USAF 2004).

A launch vehicle failure in or near the launch area during the first few seconds of flight could result in the release of the propellants onboard the Atlas V and the spacecraft. The resulting emissions from the combusted propellants would chemically resemble those from a normal launch. Debris would be expected to fall on or near the launch pad or into the Atlantic Ocean. Modeling of postulated accident consequences with meteorological parameters that would result in the greatest concentrations of emissions over land areas, reported in previous USAF environmental documentation (USAF 1998, USAF 2000), indicates that the emissions would not reach levels threatening public health.

Under the No Action Alternative, NASA would not complete preparations for and implement the New Horizons mission. The No Action Alternative would not involve any of the environmental impacts associated with potential launch-related accidents.

### **Environmental Impacts of Potential Radiological Launch Accidents**

A principal concern associated with launch of the New Horizons spacecraft involves potential accidents that could result in release of some of the radioactive material onboard the spacecraft. The spacecraft would be electrically powered by one RTG containing plutonium dioxide (containing primarily plutonium-238).

The U.S. Department of Energy (DOE) prepared a nuclear risk assessment to support this FEIS. DOE's *Nuclear Risk Assessment for the New Horizons Mission*

*Environmental Impact Statement* (DOE 2005) was prepared in advance of the more detailed Final Safety Analysis Report (FSAR) being prepared in accordance with the formal launch approval process required by Presidential Directive/National Security Council Memorandum 25 (PD/NSC-25). The risk assessment is based on a combination of scaling the results of risk assessments for past missions (e.g., the Cassini and Mars Exploration Rover missions) on a per-curie inventory basis for specific accident configurations and environments, coupled with additional analyses where considered appropriate.

Several technical issues that could impact both the accident probabilities and consequences are under continuing evaluation as part of the FSAR. These issues could not be fully addressed in the risk assessment; best engineering judgment was used to address these issues and their impact on the risk estimate for the New Horizons mission. Should the results to be reported in the FSAR differ significantly from those presented in this EIS, NASA would consider the new information and determine the need for additional environmental documentation.

The nuclear risk assessment for the New Horizons mission considers: (1) potential accidents associated with the launch, and their probabilities and accident environments; (2) the response of the RTG to such accidents in terms of the estimated amounts of radioactive material released (called source terms) and the release probabilities; and (3) the radiological consequences and risks associated with such releases.

Information on potential accidents and probabilities were developed by NASA based on information provided by the launch vehicle and third stage manufacturers and the spacecraft provider. DOE then assessed the response of the RTG to these accidents and estimated the amount of radioactive material that could be released. Finally, DOE determined the potential consequences of each release to the environment and to the potentially exposed population. Accidents were assessed over all mission launch phases, from pre-launch operations through Earth escape, and consequences were assessed for both the regional population near the launch site and the global population.

The risk assessment presented in this FEIS assumes a typical radioactive inventory of 132,500 curies. The plutonium dioxide in the RTG to be used on the New Horizons spacecraft would consist of a mixture of fuel of differing ages, yet to be finalized. Based on the latest information, the inventory in the RTG is estimated to be in the range of 108,000 to 124,000 curies. A reduction in the assumed inventory from 132,500 curies would lead to an estimated proportional decrease in the reported results.

There are a range of accidents that have different probabilities of occurrence and consequences. For this summary, the following terminology has been adopted to categorize the range of probabilities of potential launch accidents that could lead to a release of plutonium dioxide:

- unlikely – probabilities ranging from 1 in 100 to 1 in 10 thousand;
- very unlikely – probabilities ranging from 1 in 10 thousand to 1 in 1 million; and,
- extremely unlikely – probabilities of less than 1 in 1 million.

Results of the risk assessment for this FEIS show that the most likely outcome of implementing the Proposed Action would be a successful launch with no release of radioactive materials. The risk assessment did, however, identify potential launch accidents that could result in a release of plutonium dioxide in the launch area, southern Africa following suborbital reentry, and other global locations following orbital reentry. However, in each of these regions an accident resulting in a release of plutonium dioxide is unlikely (i.e., the estimated probability of such an accident in each region ranges from 1 in 100 to 1 in 10 thousand, with the data and analysis of the risk assessment indicating mean probabilities on the order of 1 in several hundred for each region.) Accidents which could occur over the Atlantic Ocean or after the spacecraft escapes the Earth's gravity field would not result in a release of plutonium dioxide.

Very unlikely and extremely unlikely launch accidents were also assessed. These events were postulated for cases in which an accident occurs in the launch area and the safety systems fail to destroy the launch vehicle. Destruction of the vehicle by these safety systems would minimize potential damage to the RTG. Even though launch accidents in which these safety systems failed have not occurred in recent history, these types of extremely unlikely accidents (i.e., the estimated probability of an accident with a release is less than 1 in 1 million) are still being evaluated as a part of the detailed analysis for the FSAR. The mean probabilities of these events are estimated to range from 1 in 1.4 million to 1 in 18 million or less. These extremely unlikely accidents could, however, expose the RTG to severe accident environments, including mechanical damage, fragments, and solid propellant fires, which could result in greater damage to the RTG and potentially greater consequences

The specific probability values presented in this FEIS are estimates and will likely differ from those presented in the more detailed FSAR being prepared by DOE for the New Horizons mission. Some probabilities will likely increase while others may decrease. However, NASA expects the overall probability of an accidental release of radioactive material will not vary substantially from the values presented in this FEIS.

#### Discussion of Radiological Impacts

The radiological impacts or consequences for each postulated accident were calculated in terms of (1) impacts to individuals in terms of the maximum individual dose (the largest expected dose that any person could receive for a particular accident); (2) impacts to the exposed portion of the population in terms of the potential for additional latent cancer fatalities due to a radioactive release (i.e., cancer fatalities that are in excess of those latent cancer fatalities which the general population would normally experience from all causes over a long-term period following the release); and (3) impacts to the environment in terms of land area contaminated at or above specified levels.

Potential environmental contamination was evaluated in terms of areas exceeding various screening levels and dose-rate related criteria. For this EIS, land areas estimated to be contaminated above a screening level of 0.2 microcuries per square meter ( $\mu\text{Ci}/\text{m}^2$ ) (used by NASA in the evaluations of previous missions) have been identified for the purpose of evaluating the need for potential characterization and cleanup. Costs associated with these efforts, should decontamination be required,

could vary widely (\$93 million to \$520 million per square kilometer or about \$241 million to \$1.3 billion per square mile) depending upon the characteristics and size of the contaminated area.

These radiological consequences are described in terms of values indicative of a range represented by the mean and 99-percentile values derived from probability distributions. The 99-th percentile of the radiological consequences is the value predicted to be exceeded one percent of the time for an accident with a release. In this context, the 99-th percentile value reflects the potential for higher radiological consequences to the exposed population at lower probabilities.

The 99-th percentile consequences have been calculated for the group of accidents that could occur in and near the launch area; for those accidents that could occur beyond the launch area, during the pre-orbit and orbit portions of the mission; and for the overall mission. The estimated radiological consequences are summarized in Table ES-1 in terms of the mean and the 99-th percentile consequences. A thorough discussion of these results is presented in Chapter 4 of this EIS.

**TABLE ES-1. ESTIMATED RADIOLOGICAL CONSEQUENCES SUMMARIZED IN TERMS OF THE MEAN AND 99-TH PERCENTILE CONSEQUENCES**

	Launch Area Accidents		Accidents Beyond The Launch Area (Pre-Orbit)		Accidents Beyond The Launch Area (Orbit)		Overall Mission Accidents	
	Mean	99-th	Mean	99-th	Mean	99-th	Mean	99-th
Probability of an Accident with a Release	1 in 620	1 in 62,000	1 in 1,300	1 in 130,000	1 in 1,100	1 in 110,000	1 in 300	1 in 30,000
Maximum Individual Dose, rem	0.3	7.1	0.1	0.8	0.4	2.5	0.3	4.3
Latent Cancer Fatalities	0.4	5.2	0.002	0.009	0.02	0.2	0.2	2.5
Land Contamination, square kilometers (square miles)	1.8 (0.7)	10.7 (4.1)	0.009 (0.003)	0.05 (0.02)	0.02 (0.008)	0.1 (0.04)	0.9 (0.3)	5.1 (2.0)

The launch area accident consequences are derived from a set of accident conditions that have a wide range of probabilities and consequences. The launch area accident mean consequences are dominated by an accident with releases in the unlikely probability category. Beyond the 99-th percentile consequence values reported above, there are other potential accidents with releases in the extremely unlikely category that could have higher consequences. The launch area accidents within these categories are discussed below.

### *Unlikely Launch Area Accidents*

For most launch-related problems that could occur prior to launch, the most likely result would be a safe hold or termination of the launch countdown. After lift-off, most accidents would lead to activation of safety systems that would result in destruction of the launch vehicle. This would also include activation of the breakup system on the third stage solid rocket motor, resulting in the RTG or its components falling to the ground where they could be subject to mechanical damage and exposure to solid propellant fires. This unlikely situation, with an estimated mean probability of approximately 1 in 620, could result in a release of about 0.01 percent of the plutonium dioxide in the RTG (about 1 gram (0.035 ounce)).

The predicted mean radiological dose to the maximally exposed individual ranges from very small to less than 1 rem for the unlikely launch area accidents. No short-term radiological effects would be expected from any of these exposures. Each exposure would, however, increase the statistical likelihood of a cancer fatality over the long term.

Impact to a population group potentially exposed to a release (i.e., the exposed subset of the total population) following an accident is estimated by calculating the collective dose. Collective dose is the sum of the radiation dose received by all the individuals in the group exposed to a given release, and could lead to potential latent cancer fatalities among the group of exposed individuals following an accident. Any such cancer fatalities would not occur promptly upon exposure, but could occur over the long term.

For the unlikely accidents with a release which could occur in and near the launch area, as well as prior to and after the spacecraft achieves orbit, additional latent cancer fatalities would be small (i.e., a mean of 0.4) among the potentially exposed members of the local and global populations. This assumes no mitigation actions, such as sheltering and exclusion of people from contaminated land areas.

Results of the risk assessment indicate that the unlikely launch area accident, involving the intentional destruction of all launch vehicle stages freeing the RTG to fall to the ground, could result in less than two square kilometers (less than one square mile) potentially contaminated above the 0.2  $\mu\text{Ci}/\text{m}^2$  screening level.

### *Extremely Unlikely Launch Area Accidents*

For extremely unlikely launch area accidents (discussed in Chapter 4 of this EIS), the vehicle safety systems are assumed to fail. The probabilities of these types of accidents range from 1 in 1.4 million to 1 in 18 million or less, and could result in higher releases of plutonium dioxide (up to 2 percent of the RTG inventory) with the potential for higher consequences.

The maximally exposed individual could receive a mean dose of 10 to 55 rem following the more severe types of extremely unlikely accidents, such as ground impact of the entire launch vehicle. It should be noted that there are very large variations and uncertainties in the prediction of close-in doses due to the large variations and uncertainties in dispersion modeling for such complicated accident situations. Assuming no mitigation actions, such as sheltering and exclusion of people from contaminated land areas, the potentially exposed members of the population could

inhale enough material to result in about 100 additional cancer fatalities over the long term.

Results of the risk assessment also indicate that for the extremely unlikely accident that involves ground impact of the entire launch vehicle, nearly 300 square kilometers (about 115 square miles) of land area could be contaminated above the 0.2  $\mu\text{Ci}/\text{m}^2$  screening level. Contamination at this level could necessitate radiological surveys and potential mitigation and cleanup actions.

Considering both the unlikely and the extremely unlikely launch accidents assessed in this FEIS, both the maximally exposed member of the exposed population and the average individual within the exposed population face a less than 1 in 1 million chance of incurring a latent cancer due to a catastrophic failure of the New Horizons mission.

#### *No Action Alternative*

Under the No Action Alternative, NASA would not complete preparations for and implement the New Horizons mission. The No Action Alternative would not involve any of the radiological risks associated with potential launch accidents.

### **SCIENCE COMPARISON**

The Proposed Action would complete NASA's reconnaissance of the known planets in our solar system, begun with Mariner 2 to Venus in 1962. The suite of instruments on the New Horizons spacecraft has been carefully selected to maximize collection of scientific data to meet the mission's objectives. Scientists would, for the first time, be able to closely examine the physical and chemical characteristics of Pluto, its moon Charon, and possibly other objects in the Kuiper Belt. These investigations of such primitive bodies could lead to fundamentally new insights into the formation and evolution of the solar system.

Under the No Action Alternative none of the science planned for the New Horizons mission to Pluto would be obtained.

## TABLE OF CONTENTS VOLUME 1

<u>Section</u>	<u>Page</u>
<b>ABSTRACT .....</b>	<b>iii</b>
<b>EXECUTIVE SUMMARY .....</b>	<b>v</b>
<b>LIST OF FIGURES.....</b>	<b>xvii</b>
<b>LIST OF TABLES .....</b>	<b>xviii</b>
<b>ABBREVIATIONS AND ACRONYMS.....</b>	<b>xix</b>
<b>COMMON METRIC/BRITISH SYSTEM EQUIVALENTS .....</b>	<b>xxiii</b>
<b>1 PURPOSE AND NEED FOR THE ACTION.....</b>	<b>1-1</b>
1.1 BACKGROUND.....	1-1
1.1.1 Pluto and Charon.....	1-1
1.1.2 The Kuiper Belt.....	1-2
1.2 PURPOSE OF THE ACTION .....	1-3
1.3 NEED FOR THE ACTION .....	1-4
1.4 NEPA PLANNING AND SCOPING ACTIVITIES.....	1-6
1.5 RESULTS OF PUBLIC REVIEW OF THE DRAFT EIS .....	1-7
<b>2 DESCRIPTION AND COMPARISON OF ALTERNATIVES .....</b>	<b>2-1</b>
2.1 DESCRIPTION OF THE PROPOSED ACTION .....	2-1
2.1.1 Mission Description.....	2-1
2.1.2 Spacecraft Description.....	2-4
2.1.3 Spacecraft Electrical Power .....	2-4
2.1.3.1 Electrical Power Performance Criteria .....	2-5
2.1.3.2 The Radioisotope Thermoelectric Generator .....	2-7
2.1.4 Space Launch Complex-41.....	2-11
2.1.5 Spacecraft Processing.....	2-12
2.1.6 Description of the Atlas V Launch Vehicle .....	2-12
2.1.6.1 First Stage.....	2-13
2.1.6.2 Centaur Second Stage.....	2-14
2.1.6.3 Third Stage .....	2-14
2.1.6.4 Payload Fairing .....	2-14
2.1.6.5 Flight Termination System .....	2-15
2.1.6.6 Launch Vehicle Processing.....	2-16
2.1.6.7 Launch Profile .....	2-16
2.1.7 Range Safety Considerations .....	2-17
2.1.8 Electromagnetic Environment.....	2-18
2.2 DESCRIPTION OF THE NO ACTION ALTERNATIVE.....	2-18
2.3 ALTERNATIVES CONSIDERED BUT NOT EVALUATED FURTHER....	2-18
2.3.1 Alternative Power Sources.....	2-18
2.3.1.1 Other Radioisotope RTGs.....	2-19

2.3.1.2	Power Systems Requiring Less Plutonium Dioxide .....	2-19
2.3.1.3	Solar Energy Power Systems .....	2-20
2.3.2	Alternative Trajectories .....	2-20
2.3.2.1	Gravity Assist Trajectories .....	2-20
2.3.2.2	Low Thrust Trajectories.....	2-21
2.4	COMPARISON OF ALTERNATIVES INCLUDING THE PROPOSED ACTION.....	2-22
2.4.1	Environmental Impacts of a Normal Launch .....	2-22
2.4.2	Environmental Impacts of Potential Nonradiological Launch Accidents .....	2-24
2.4.3	Environmental Impacts of Potential Radiological Launch Accidents .....	2-25
2.4.3.1	The EIS Nuclear Risk Assessment .....	2-26
2.4.3.2	Accident Consequences .....	2-28
2.4.3.3	Mission Risks .....	2-32
2.4.4	Radiological Contingency Response Planning .....	2-34
<b>3</b>	<b>DESCRIPTION OF THE AFFECTED ENVIRONMENT .....</b>	<b>3-1</b>
3.1	CAPE CANAVERAL AIR FORCE STATION REGIONAL AREA.....	3-1
3.1.1	Land Use .....	3-1
3.1.2	Atmospheric Environment.....	3-4
3.1.2.1	Climate.....	3-4
3.1.2.2	Air Quality .....	3-4
3.1.3	Ambient Noise .....	3-7
3.1.4	Geology and Soils.....	3-7
3.1.5	Hydrology and Water Quality .....	3-7
3.1.5.1	Surface Waters .....	3-7
3.1.5.2	Surface Water Quality .....	3-9
3.1.5.3	Groundwater Sources .....	3-9
3.1.5.4	Groundwater Quality .....	3-11
3.1.5.5	Offshore Environment .....	3-11
3.1.6	Biological Resources .....	3-12
3.1.6.1	Terrestrial Resources.....	3-12
3.1.6.2	Aquatic Resources .....	3-13
3.1.6.3	Threatened and Endangered Species.....	3-14
3.1.7	Socioeconomics.....	3-16
3.1.7.1	Population .....	3-16
3.1.7.2	Economy .....	3-18
3.1.7.3	Transportation Systems .....	3-19
3.1.7.4	Public and Emergency Services .....	3-19
3.1.7.5	Recreation.....	3-20
3.1.7.6	Cultural/Historic/Archaeological Resources .....	3-20
3.2	THE GLOBAL ENVIRONMENT .....	3-21
3.2.1	Troposphere .....	3-21
3.2.2	Stratosphere .....	3-21
3.2.3	Population Distribution and Density .....	3-23
3.2.4	Surface Types.....	3-24
3.2.5	Background Radiation .....	3-24



3.2.5.1	Natural and Manmade Sources .....	3-24
3.2.5.2	Worldwide Plutonium Levels .....	3-24
<b>4</b>	<b>ENVIRONMENTAL CONSEQUENCES .....</b>	<b>4-1</b>
4.1	ENVIRONMENTAL IMPACTS OF THE PROPOSED ACTION .....	4-1
4.1.1	Environmental Consequences of Preparing for Launch .....	4-2
4.1.2	Environmental Impacts of a Normal Launch .....	4-3
4.1.2.1	Land Use .....	4-3
4.1.2.2	Air Quality .....	4-3
4.1.2.3	Noise .....	4-4
4.1.2.4	Geology and Soils .....	4-5
4.1.2.5	Hydrology and Water Quality .....	4-5
4.1.2.6	Offshore Environment .....	4-6
4.1.2.7	Biological Resources .....	4-6
4.1.2.8	Socioeconomics .....	4-7
4.1.2.9	Environmental Justice .....	4-7
4.1.2.10	Cultural/Historic/Archaeological Resources .....	4-7
4.1.2.11	Health and Safety .....	4-8
4.1.2.12	Global Environment .....	4-8
4.1.2.13	Orbital and Reentry Debris .....	4-10
4.1.3	Environmental Impacts of Potential Accidents Not Involving Radioactive Material .....	4-10
4.1.3.1	Liquid Propellant Spills .....	4-11
4.1.3.2	Launch Failures .....	4-11
4.1.4	Environmental Impacts of Potential Accidents Involving Radioactive Material .....	4-13
4.1.4.1	Risk Assessment Methodology .....	4-14
4.1.4.2	Launch Accidents and Accident Probabilities .....	4-17
4.1.4.3	RTG Response to Accident Environments .....	4-21
4.1.4.4	Accident Probabilities and Source Terms .....	4-24
4.1.4.5	Radiological Consequences .....	4-26
4.1.4.6	Discussion of the Results .....	4-30
4.1.4.7	Impacts of Radiological Releases on the Environment ..	4-31
4.1.4.8	Mission Risks .....	4-34
4.1.4.9	Uncertainty .....	4-36
4.1.5	Radiological Contingency Response Planning .....	4-36
4.2	ENVIRONMENTAL IMPACTS OF THE NO ACTION ALTERNATIVE ....	4-37
4.3	CUMULATIVE IMPACTS .....	4-37
4.4	ENVIRONMENTAL EFFECTS THAT CANNOT BE AVOIDED .....	4-39
4.5	INCOMPLETE OR UNAVAILABLE INFORMATION .....	4-39
4.6	RELATIONSHIP BETWEEN SHORT-TERM USES OF THE HUMAN ENVIRONMENT AND THE MAINTENANCE AND ENHANCEMENT OF LONG-TERM PRODUCTIVITY .....	4-40
4.6.1	Short-Term Uses .....	4-40
4.6.2	Long-Term Productivity .....	4-41
4.7	IRREVERSIBLE AND IRRETRIEVABLE COMMITMENT OF RESOURCES .....	4-41
4.7.1	Energy and Fuels .....	4-41

4.7.2 Other Materials ..... 4-42  
4.8 ENVIRONMENTAL COMPLIANCE AT CCAFS ..... 4-42  
5 LIST OF PREPARERS ..... 5-1  
6 AGENCIES, ORGANIZATIONS AND INDIVIDUALS CONSULTED ..... 6-1  
7 INDEX ..... 7-1  
8 REFERENCES ..... 8-1

**TABLE OF CONTENTS  
VOLUME 2**

APPENDIX A: GLOSSARY OF TERMS..... A-1  
APPENDIX B: EFFECTS OF PLUTONIUM ON THE ENVIRONMENT ..... B-1  
APPENDIX C: ENVIRONMENTAL JUSTICE ANALYSIS..... C-1  
APPENDIX D: RESPONSES TO PUBLIC REVIEW COMMENTS..... D-1  
APPENDIX E: PUBLIC REVIEW AND COMMENT MEETINGS ..... E-1

## LIST OF FIGURES

<b><u>Figure</u></b>	<b><u>Page</u></b>
2-1. THE NEW HORIZONS 2006 JUPITER GRAVITY ASSIST TRAJECTORY .....	2-2
2-2. NEW HORIZONS MISSION PLUTO-CHARON ENCOUNTER GEOMETRY....	2-3
2-3. MAJOR COMPONENTS OF THE NEW HORIZONS SPACECRAFT .....	2-5
2-4. ILLUSTRATION OF A RADIOISOTOPE THERMOELECTRIC GENERATOR.....	2-7
2-5. DIAGRAM OF A GENERAL PURPOSE HEAT SOURCE AEROSHELL MODULE.....	2-9
2-6. ILLUSTRATION OF AN ATLAS V 551 LAUNCH VEHICLE .....	2-13
2-7. ILLUSTRATION OF THE NEW HORIZONS ATLAS V PAYLOAD FAIRING ..	2-14
2-8. TYPICAL ATLAS V ASCENT PROFILE .....	2-17
2-9. LAUNCH-RELATED PROBABILITIES .....	2-25
3-1. THE REGIONAL AREA NEAR CCAFS .....	3-2
3-2. CCAFS AND THE SURROUNDING AREA.....	3-3
3-3. SURFACE WATER CLASSIFICATIONS NEAR CCAFS.....	3-8
3-4. OUTSTANDING FLORIDA WATERS AND AQUATIC PRESERVES NEAR CCAFS .....	3-10
3-5. POPULATION CENTERS IN THE CCAFS REGIONAL AREA .....	3-16
3-6. POPULATION GROUPS IN THE CCAFS REGIONAL AREA.....	3-18
3-7. ATMOSPHERIC LAYERS AND THEIR ESTIMATED ALTITUDE .....	3-22
4-1. LAUNCH-RELATED PROBABILITIES .....	4-2
4-2. THE RADIOLOGICAL RISK ASSESSMENT METHODOLOGY.....	4-15

## LIST OF TABLES

<u>Table</u>	<u>Page</u>
ES-1. ESTIMATED RADIOLOGICAL CONSEQUENCES SUMMARIZED IN TERMS OF THE MEAN AND 99-TH PERCENTILE CONSEQUENCES .....	x
2-1. OVERVIEW OF THE FUNCTION AND PURPOSE OF THE NEW HORIZONS SCIENCE INSTRUMENTS.....	2-6
2-2. UNITED STATES SPACE MISSIONS INVOLVING RADIOISOTOPE POWER SOURCES .....	2-8
2-3. TYPICAL ISOTOPIC COMPOSITION OF AN RTG.....	2-10
2-4. SUMMARY COMPARISON OF THE NEW HORIZONS MISSION ALTERNATIVES.....	2-23
2-5. CALCULATED INDIVIDUAL RISK AND PROBABILITY OF FATALITY BY VARIOUS CAUSES IN THE UNITED STATES IN 2000 .....	2-34
3-1. CLIMATOLOGY DATA FOR BREVARD COUNTY, FLORIDA.....	3-5
3-2. SUMMARY AIR QUALITY DATA NEAR CCAFS FOR 2002.....	3-6
3-3. MAJOR LAND COVER TYPES IN THE CCAFS REGIONAL AREA.....	3-12
3-4. THREATENED, ENDANGERED, AND SPECIES OF SPECIAL CONCERN OCCURRING ON OR NEAR CCAFS.....	3-15
3-5. POPULATION OF THE CCAFS REGIONAL AREA.....	3-17
3-6. GLOBAL POPULATION AND SURFACE CHARACTERISTICS BY LATITUDE BAND .....	3-23
3-7. AVERAGE ANNUAL EFFECTIVE DOSE EQUIVALENT OF IONIZING RADIATION TO A MEMBER OF THE U.S. POPULATION .....	3-25
4-1. INITIATING FAILURES THAT CONTRIBUTE TO PRE-LAUNCH END STATES.....	4-19
4-2. INITIATING FAILURES THAT CONTRIBUTE TO POST LAUNCH END STATES .....	4-20
4-3. ACCIDENT PROBABILITIES AND SOURCE TERMS .....	4-25
4-4. ESTIMATED RADIOLOGICAL CONSEQUENCES.....	4-28
4-5. POTENTIAL LAND DECONTAMINATION COST FACTORS .....	4-33
4-6. SUMMARY OF HEALTH EFFECT MISSION RISKS .....	4-34
4-7. HEALTH EFFECT MISSION RISK CONTRIBUTIONS BY AFFECTED REGION .....	4-35
4-8. AVERAGE INDIVIDUAL RISK BY AFFECTED REGION .....	4-35

## ABBREVIATIONS AND ACRONYMS

<b>A</b>			
ac	acre(s)	CDS	Command Destruct System
AEC	U.S. Atomic Energy Commission	CEQ	Council on Environmental Quality
ADS	Automatic Destruct System	CFR	Code of Federal Regulations
AIAA	American Institute of Aeronautics and Astronautics	Ci	curie(s)
AIHA	American Industrial Hygiene Association	cm	centimeter(s)
Al <sub>2</sub> O <sub>3</sub>	aluminum oxide	Cm	curium
ALICE	Ultraviolet (UV) Imaging Spectrometer	cm <sup>3</sup>	cubic centimeter(s)
ALSEP	Apollo Lunar Surface Experiments Package	CO	carbon monoxide
APL	Applied Physics Laboratory	CO <sub>2</sub>	carbon dioxide
Atlas V	Atlas V 551 Launch Vehicle	CSC	conical shaped charge
AU	astronomical unit(s)		
<b>B</b>		<b>D</b>	
BDM	biological defense mechanism	dba	decibels (A-weighted)
BEBR	Bureau of Economic and Business Research	DEIS	Draft Environmental Impact Statement
BLS	U.S. Bureau of Labor and Statistics	DHS	U.S. Department of Homeland Security
BUS	Breakup System (third stage solid rocket motor)	DOI	U.S. Department of the Interior
		DOE	U.S. Department of Energy
		DOD	U.S. Department of Defense
		ΔV	Delta-V (change in velocity)
		ΔVEGA	Delta-V Earth Gravity Assist
<b>C</b>		<b>E</b>	
°C	degrees Celsius	E	Endangered (species)
C/A	closest approach	EA	Environmental Assessment
CAA	Clean Air Act	EFH	essential fish habitat
CADS	Centaur Automatic Destruct System	EIS	Environmental Impact Statement
CAIB	Columbia Accident Investigation Board	EO	Executive Order
CCAFS	Cape Canaveral Air Force Station	EPA	U.S. Environmental Protection Agency

	<b>F</b>		
°F	degrees Fahrenheit	ISDS	Inadvertent Separation Destruct System
FAA	Federal Aviation Administration	INSRP	Interagency Nuclear Safety Review Panel
FDEP	Florida Department of Environmental Protection		<b>J</b>
FR	<i>Federal Register</i>	JGA	Jupiter Gravity Assist
FSII	full stack intact impact		<b>K</b>
FSAR	Final Safety Analysis Report	KBO	Kuiper Belt Object(s)
ft	feet	kg	kilogram(s)
ft/s	feet per second	km	kilometer(s)
FTS	Flight Termination System	km/hr	kilometers per hour
FWS	U.S. Fish and Wildlife Service	km <sup>2</sup>	square kilometer(s)
	<b>G</b>	KSC	Kennedy Space Center
g	gram(s)		<b>L</b>
gal	gallon(s)	l	liter(s)
GIS	graphite impact shell	lb	pound(s)
GPHS	general purpose heat source	LDRRP	Low Dose Radiation Research Program
GSE	ground support equipment	LEISA	Linear Etalon Imaging Spectral Array
	<b>H</b>	LH <sub>2</sub>	liquid hydrogen
H <sub>2</sub>	hydrogen	LMMS	Lockheed Martin Missiles and Space
H <sub>2</sub> O	water	LNT	Linear, No-Threshold
ha	hectare(s)	LMILS	Lockheed Martin International Launch Services
HCl	hydrogen chloride	LORRI	Long Range Reconnaissance Imager
HGA	high gain antenna	LO <sub>2</sub>	liquid oxygen
HHS	U.S. Department of Health and Human Services		<b>M</b>
HST	Hubble Space Telescope	μCi/m <sup>2</sup>	microcurie(s) per square meter
HTPB	hydroxyl-terminated polybutadiene	μg/m <sup>3</sup>	microgram(s) per cubic meter
	<b>I</b>	m <sup>3</sup>	cubic meter(s)
IAEA	International Atomic Energy Agency	m	meter(s)
ICRP	International Commission on Radiological Protection	m/s	meters per second
in	inch(s)	MFCO	Mission Flight Control Officer

mg/l	milligrams per liter		
MHW	Multi-Hundred Watt	O <sub>3</sub>	ozone
mi	mile(s)	oz	ounce(s)
MINWR	Merritt Island National Wildlife Refuge		
MMRTG	Multi-Mission Radioisotope Thermoelectric Generator		
mph	miles per hour		
mrem	millirem(s)		
mt	metric ton(s)		
MVIC	Multispectral Visible Imaging Camera		
	<b>N</b>		
N <sub>2</sub>	nitrogen		
N <sub>2</sub> O	nitrous oxide		
NA	not applicable		
NAAQS	National Ambient Air Quality Standards		
NASA	National Aeronautics and Space Administration		
NCRP	National Council on Radiation Protection and Measurements		
NEP	nuclear-electric propulsion		
NEPA	National Environmental Policy Act		
NLS	National Launch Services		
NMFS	National Marine Fisheries Service		
nmi	nautical mile(s)		
NOAA	National Oceanic and Atmospheric Administration		
NO <sub>2</sub>	nitrogen dioxide		
NO <sub>x</sub>	oxides of nitrogen		
NOA	Notice of Availability		
NOI	Notice of Intent		
NPS	National Park Service		
NRC	National Research Council		
NRHP	National Register of Historic Places		
NRP	National Response Plan		
			<b>O</b>
			<b>P</b>
		PAF	payload attach fitting
		PAFB	Patrick Air Force Base
		Pb	lead
		PEPSSI	Pluto Energetic Particle Spectrometer Science Investigation
		PERSI	Pluto Exploration Remote Sensing Instrument
		PHSF	Payload Hazardous Servicing Facility
		PLF	payload fairing
		PM <sub>2.5</sub>	particulate matter less than 2.5 microns in diameter
		PM <sub>10</sub>	particulate matter less than 10 microns in diameter
		ppm	parts per million
		Pu	plutonium
		PuO <sub>2</sub>	plutonium dioxide
			<b>R</b>
		RADCC	Radiological Control Center
		REX	Radio Science Experiment
		RLSP	Request for Launch Services Proposal
		RP-1	rocket propellant-1
		RPS	radioisotope power system
		RTG	radioisotope thermoelectric generator
			<b>S</b>
		S/A	Similarity of Appearance
		s	second(s)
		SC	spacecraft
		SDC	Student Dust Counter
		SEP	solar-electric propulsion

SFWMD	South Florida Water Management District		
SJRWMD	St. Johns River Water Management District	T	<b>T</b> time, mission elapsed; Threatened (species)
SLC	space launch complex		
SNAP	Systems for Nuclear Auxiliary Power	UNSCEAR	<b>U</b> United Nations Scientific Committee on the Effects of Atomic Radiation
SO <sub>2</sub>	sulfur dioxide		
Sr	strontium	USAF	U.S. Air Force
SRB	solid rocket booster	USBC	U.S. Bureau of the Census
SRG	Stirling Radioisotope Generator	U.S.C.	United States Code
SRM	solid rocket motor	UV	ultraviolet
SSC	Species of Special Concern		<b>V</b>
Sv	sievert	VIF	Vertical Integration Facility
SWAP	Solar Wind Around Pluto		<b>Y</b>
		yr	year



## COMMON METRIC/BRITISH SYSTEM EQUIVALENTS

### Length

1 centimeter (cm) = 0.3937 inch	1 inch = 2.54 cm
1 centimeter = 0.0328 foot (ft)	1 foot = 30.48 cm
1 meter (m) = 3.2808 feet	1 ft = 0.3048 m
1 meter = 0.0006 mile (mi)	1 mi = 1609.3440 m
1 kilometer (km) = 0.6214 mile	1 mi = 1.6093 km
1 kilometer = 0.53996 nautical mile (nmi)	1 nmi = 1.8520 km
	1 mi = 0.87 nmi
	1 nmi = 1.15 mi

### Area

1 square centimeter (cm <sup>2</sup> ) = 0.1550 square inch (in <sup>2</sup> )	1 in <sup>2</sup> = 6.4516 cm <sup>2</sup>
1 square meter (m <sup>2</sup> ) = 10.7639 square feet (ft <sup>2</sup> )	1 ft <sup>2</sup> = 0.09290 m <sup>2</sup>
1 square kilometer (km <sup>2</sup> ) = 0.3861 square mile (mi <sup>2</sup> )	1 mi <sup>2</sup> = 2.5900 km <sup>2</sup>
1 hectare (ha) = 2.4710 acres (ac)	1 ac = 0.4047 ha
1 hectare (ha) = 10,000 square meters (m <sup>2</sup> )	1 ft <sup>2</sup> = 0.000022957 ac

### Volume

1 cubic centimeter (cm <sup>3</sup> ) = 0.0610 cubic inch (in <sup>3</sup> )	1 in <sup>3</sup> = 16.3871 cm <sup>3</sup>
1 cubic meter (m <sup>3</sup> ) = 35.3147 cubic feet (ft <sup>3</sup> )	1 ft <sup>3</sup> = 0.0283 m <sup>3</sup>
1 cubic meter (m <sup>3</sup> ) = 1.308 cubic yards (yd <sup>3</sup> )	1 yd <sup>3</sup> = 0.76455 m <sup>3</sup>
1 liter (l) = 1.0567 quarts (qt)	1 qt = 0.9463264 l
1 liter = 0.2642 gallon (gal)	1 gal = 3.7845 l
1 kiloliter (kl) = 264.2 gal	1 gal = 0.0038 kl

### Weight

1 gram (g) = 0.0353 ounce (oz)	1 oz = 28.3495 g
1 kilogram (kg) = 2.2046 pounds (lb)	1 lb = 0.4536 kg
1 metric ton (mt) = 1.1023 tons	1 ton = 0.9072 metric ton

### Energy

1 joule = 0.0009 British thermal unit (BTU)	1 BTU = 1054.18 joule
1 joule = 0.2392 gram-calorie (g-cal)	1 g-cal = 4.1819 joule

### Pressure

1 newton/square meter (N/m <sup>2</sup> ) = 0.0208 pound/square foot (psf)	1 psf = 48 N/m <sup>2</sup>
---	-----------------------------

### Force

1 newton (N) = 0.2248 pound-force (lbf)	1 lbf = 4.4478 N
---	------------------

### Radiation

1 becquerel (Bq) = 2.703 x 10 <sup>-11</sup> curies (Ci)	1 Ci = 3.70 x 10 <sup>10</sup> Bq
1 sievert (Sv) = 100 rem	1 rem = 0.01 Sv

This page intentionally left blank.

# 1 PURPOSE AND NEED FOR THE ACTION

This Final Environmental Impact Statement (FEIS) has been prepared by the National Aeronautics and Space Administration (NASA) to assist in the decision-making process as required by the National Environmental Policy Act of 1969 (NEPA), as amended (42 U.S.C. 4321 et seq.); Executive Order (EO) 12114, *Environmental Effects Abroad of Major Federal Actions*; Council on Environmental Quality Regulations (40 CFR parts 1500–1508); and NASA policies and procedures at 14 CFR part 1216. NASA solicited proposals for a Pluto-Kuiper Belt mission in an Announcement of Opportunity (AO 01-OSS-01) dated January 19, 2001. This FEIS provides information associated with potential environmental impacts of continuing preparations for and implementing the selected New Horizons mission, which would conduct scientific investigations of Pluto, its moon Charon, and possibly the Kuiper Belt. Launch of the New Horizons mission to Pluto is planned from Cape Canaveral Air Force Station (CCAFS), Florida, during the January – February 2006 opportunity, with a potential backup opportunity in February 2007. Chapter 2 of this FEIS evaluates the alternatives considered to achieve the New Horizons mission.

## 1.1 BACKGROUND

### 1.1.1 Pluto and Charon

Clyde W. Tombaugh discovered Pluto, the outermost known planet, in 1930, culminating a long photographic search. Many years previously, Percival Lowell had studied the slight differences between the observed and predicted motions of Uranus and Neptune, and had calculated where the unknown mass responsible for these effects might be found. Working at the Lowell Observatory in Arizona, Tombaugh located the elusive planet not very far from Lowell's predicted position.

Pluto differs drastically from the other four outer planets, which are gas giants. It is far smaller, made of a mixture of ice and rock, and orbits the Sun more slowly. Pluto's orbit is inclined by 17° to the plane of the other eight planets in the solar system (called the ecliptic plane). Its orbit is highly elliptical (elongated), with a perihelion (closest point to the Sun) of nearly 30 astronomical units<sup>1</sup> (AU) and aphelion (farthest point from the Sun) of nearly 50 AU. The uniqueness of its orbit, highly elliptical and not in the ecliptic plane, strongly suggests that Pluto was captured into its orbit at a later time than the other planets.

In 1978, James Christy of the U.S. Naval Observatory was studying photographic plates of Pluto, working on refining Pluto's orbit parameters. He noticed that Pluto appeared to have an irregularly shaped object attached to its side, and that the object seemed to move around Pluto. Charon, the moon of Pluto, was thus discovered and its existence confirmed when it was seen to eclipse Pluto every 6.4 days.

---

<sup>1</sup> One astronomical unit is the average radius of Earth's nearly circular orbit around the Sun, about 149.6 million kilometers (93 million miles).

During the period from 1985 through 1990, Pluto and Charon eclipsed each other on a daily basis as seen from Earth. These eclipses turned out to be very important, since observations of the eclipses led to the first accurate determination of Pluto's and Charon's sizes. As viewed from Earth, the brightness of the Pluto-Charon pair decreased during each eclipse because part of either Pluto or Charon is obscured. The larger the obscuring object, the longer the eclipse will last. From these observations it was determined that Charon is approximately 1,200 kilometers (745 miles) in diameter and Pluto is about 2,330 kilometers (1,448 miles). Thus, Charon is over half of Pluto's diameter, making it the largest satellite relative to its parent planet. The next closest pair in relative size is the Earth-Moon system.

Occasionally Pluto will cross in front of a reasonably bright star, an event called a stellar occultation. A significantly bright stellar occultation occurred in June 1988 and provided the first direct evidence of Pluto's atmosphere. For brief times at both the beginning and end of the occultation Pluto's atmosphere was backlit by the star. By carefully modeling the refractivity of the atmosphere (which depends on temperature and pressure), researchers determined that a large part of Pluto's middle atmosphere has a single temperature of about  $-173^{\circ}$  Celsius ( $-280^{\circ}$  Fahrenheit), and that there is either a temperature inversion or a haze layer near the surface (NRC 1998).

Recent images taken by the Hubble Space Telescope (HST) show Pluto to be an unusually complex object, with roughly 12 major regions, some bright and some dark. Earth is the only other object in the solar system that displays so much contrast. Topographic features such as basins or fresh impact craters may cause some of these variations. However, most of the surface features unveiled by HST, including the prominent northern polar cap, are likely produced by the complex distribution of frosts that are believed to migrate across Pluto's surface with its orbital and seasonal cycles, and photochemical by-products deposited out of Pluto's nitrogen-methane atmosphere. Dynamic changes in the atmosphere are believed to drive dynamic changes in surface appearance, particularly the size and distribution of bright and dark regions.

Earth-based observations show that Pluto's surface is covered with ices and relatively volatile (easily evaporated) compounds. Nitrogen is the dominant species with much less methane and a trace of carbon monoxide. Water has also been detected, but its relative abundance is currently unknown. Observations also indicate that considerable water is present on Charon; other volatile species are suspected but have not yet been detected.

### 1.1.2 The Kuiper Belt

Decades ago, Dutch astronomer Gerard Kuiper postulated that when the solar system formed from a vast dust cloud, a large collection of small pieces was left over. This "Kuiper Belt" of objects was believed to be largely confined within a few degrees of the ecliptic plane in a ring, or belt, lying beyond Neptune. The first Kuiper Belt Objects (KBO) were discovered in 1992 by D.C. Jewitt and J.X. Luu (NRC 1998). On the order of 1,000 objects have been discovered to date, about two-thirds of which have reliably determined orbits (Millis 2003). Tens of thousands of KBOs on the order of 100 kilometers (62 miles) in diameter, and millions to billions of smaller objects, are thought

to exist in the radial zone extending outward from 30 AU (the orbit of Neptune) to at least 55 AU. KBOs are presently being discovered at a rate of 20 to 30 per month. Some KBOs have been observed within the orbit of Neptune; these are believed to have been deflected into highly elliptical planet-crossing orbits due to gravitational perturbations caused by Neptune.

Spectroscopic measurements of a small subset of KBOs show that they have diverse colors and, presumably, surface compositions. KBOs are believed to be a representative sample of the primordial material that condensed into the solar system (NRC 1998). Most if not all KBOs are believed to have spent their entire history far from the Sun in a deep freeze. Little or no opportunity has occurred for their lighter components to have been vaporized and driven off by the Sun's heat. Therefore, great interest exists in knowing their composition because it is believed to represent the starting composition from which the solar system evolved over the past 4 billion years.

## **1.2 PURPOSE OF THE ACTION**

The purpose of the action addressed in this FEIS is to further our knowledge of Pluto, the outermost known planet of our solar system, and its moon, Charon. The goal of the proposed Pluto-Kuiper Belt mission would be to measure the fundamental physical and chemical properties of the Pluto-Charon system. Specifically, the Pluto-Kuiper Belt mission would acquire remote sensing and radio occultation data to address the following scientific objectives. The first three science objectives on this list were identified as having considerably higher priority than the remainder. The Announcement of Opportunity specified that any selected mission must address these three objectives as a minimum condition.

- Characterize the global geology and morphology of Pluto and Charon.
- Map the surface composition of Pluto and Charon.
- Characterize the neutral (uncharged) atmosphere of Pluto and its rate of escape.
- Characterize the time variability of Pluto's surface and atmosphere.
- Acquire stereo images of Pluto and Charon.
- Map the day/night terminators of Pluto and Charon with high resolution.
- Map the surface compositions of selected areas of Pluto and Charon with high resolution.
- Characterize Pluto's ionosphere and its interactions with the solar wind.
- Search for hydrogen, cyanide, other neutral chemical species, hydrocarbons, and nitriles in Pluto's upper atmosphere.
- Search for an atmosphere around Charon.
- Determine the albedos (reflected brightness) of Pluto and Charon.
- Map the surface temperatures of Pluto and Charon.
- Characterize the energetic particle environment of the Pluto-Charon system.

- Refine physical parameters such as radius, mass, and density of Pluto and Charon.
- Refine the orbit parameters of Pluto and Charon.
- Search for magnetic fields.
- Search for additional satellites and rings.

The suite of science instruments onboard the Pluto-Kuiper Belt spacecraft has been carefully selected to obtain measurements which will address these objectives.

After completion of the Pluto-Charon flyby and return of the collected science data, the spacecraft could continue on an extended mission to encounter and study one or more objects within the Kuiper Belt. The remote science instrumentation planned for Pluto and Charon would also be used for investigations of these objects.

In addition, scientists selected by NASA for participation in the Pluto-Kuiper Belt mission would actively contribute to NASA's goals for the improvement of science education and the public understanding of science.

### **1.3 NEED FOR THE ACTION**

Orbiting at the outer edge of the solar system and just within the Kuiper Belt, Pluto and Charon hold chemical clues to the conditions at the boundary between the protoplanetary disk (the flat, spinning disk of gas and dust which condensed and aggregated into the planets) and the larger molecular cloud from which the disk formed. These chemical clues are likely to be at least partially preserved in the molecular composition of the ices on Pluto and Charon, which have never been exposed to the higher temperatures and solar radiation levels experienced by the other planets. Pluto's large size and brightness relative to other icy bodies has made it (barely) accessible to studies from Earth. Results of these studies indicate that it possesses a surface containing frosts of very volatile species that also occur in comets and are confirmed or suspected to be present in interstellar molecular clouds. The density of Pluto is consistent with a mixture of rock and ice that is close to the value predicted for primitive solar system material.

Pluto is known to have an atmosphere unique in the solar system. The atmosphere is thought to be transient and will collapse and condense on the surface as Pluto continues to retreat and cool from its 1989 closest approach to the Sun. Pluto's low gravity means that the atmosphere must be escaping the planet at a relatively rapid rate, making it intermediate in stability between the tenuous atmospheres (gaseous tails) of comets and the more stable atmospheres of larger planets.

What is known of Pluto is enough to make this smallest planet intriguing, but much remains unknown. How the ices are distributed across Pluto's surface or how impacts from collisions with smaller KBOs, for example, and geologic events have shaped its surface are unknown. Small amounts of many chemical species undoubtedly exist on the surface beyond those already detected. The nature of the dark material on Pluto is unknown, in particular whether it is simply silicates or organic material processed by cosmic rays or sunlight. The structure of the atmosphere is only inferentially

understood, and available models only hint at its composition and dynamics. How the atmosphere will actually respond to the decrease in solar illumination as Pluto recedes from the Sun is unknown. Pluto is suspected to not have a significant magnetic field. Even a small magnetization would suffice to deflect the solar wind, which to some extent would help preserve the atmosphere. However, if such a magnetic field is not present, the inferred rates at which the atmosphere is escaping suggest a comet-like interaction with the solar wind, an interaction that would be unique for a planet in the solar system.

Far less is known about Charon, including its origin, surface appearance, compositional relationship to Pluto. The surfaces of both Pluto and Charon might show the scars of their early history in terms of craters and tectonics induced by impacts or tides, but we cannot tell without high resolution imagery. The close correspondence in the sizes of Pluto and Charon is also a mystery. There are large and scientifically tantalizing differences between these two objects orbiting each other in close proximity. Charon appears to have no measurable atmosphere, no methane or carbon monoxide, but much more water than Pluto.

Many of the questions posed about Pluto and Charon can only be addressed by a spacecraft mission that brings advanced instruments close to the two bodies. Scientific knowledge of all other planets and their moons, and thus understanding of the nature of the solar system, has been increased enormously through visits by spacecraft. The Pluto-Charon system remains the last unvisited planetary sized set of objects in the solar system.

The science to be performed at Pluto and Charon is time-critical because of long-term seasonal changes in the surfaces and atmospheres of both bodies. The objectives of surface mapping and surface composition mapping would be significantly compromised if the spacecraft does not arrive at the Pluto-Charon system before this system recedes too far from the Sun. As one polar region on each object becomes increasingly hidden in shadow, these polar regions would be lost to imaging and spectroscopic measurements, thus limiting the amount of global geology and composition mapping that could be achieved. Furthermore, Pluto's withdrawal from perihelion is widely anticipated to result in substantial decline, if not complete collapse, of its atmosphere. Much of the atmospheric science could be lost if the atmosphere collapses or significantly declines before the spacecraft's arrival. The search for an atmosphere around Charon would also be adversely affected, or completely lost, as would the opportunity to detect and study any atmospheric transfer between Pluto and Charon, a phenomenon which could be unique in the solar system (NRC 2003).

The recent discovery of the Kuiper Belt beyond Neptune has opened another dimension for a mission of exploration. KBOs, in stable and well-defined orbits that have never taken them close to the Sun, are likely to be remnants of solar system formation and hold many clues to the birth of the planets. A mission extension beyond Pluto to visit one or more of these objects would be an extraordinary complement to a Pluto-Charon flyby, such that the whole suite of outermost primitive bodies from comet-sized objects to planets will have been visited and studied by remote sensing instruments. It may be possible to conduct a systematic search and inventory of KBOs near the spacecraft's

flight path to count and characterize bodies smaller than those that can be observed from Earth. Knowledge of the size and mass distribution of objects in the Kuiper Belt would be of great value in developing theoretical models of the evolution and destiny of the solar system.

#### **1.4 NEPA PLANNING AND SCOPING ACTIVITIES**

On October 7, 1998, NASA published a Notice of Intent (NOI) in the *Federal Register* (63 FR 53938) to prepare an Environmental Impact Statement and conduct scoping for the Pluto-Kuiper Express mission. The scoping period closed on November 23, 1998 but was reopened and extended until December 18, 1998. Comments were solicited from Federal, State and local organizations, and interested parties on the scope of the EIS. Scoping comments were received from one Federal Agency, one Florida County Agency, one private organization, and ten individuals.

Since publication of the NOI, NASA prepared further evaluations of the mission design, including the alternatives indicated in the NOI. These evaluations have resulted in refinement of NASA's original baseline plan for the mission, specifically with respect to details such as specific launch dates, launch vehicle options, and the possible use of a new radioisotope power system (RPS) for spacecraft power.

An Information Update was published in the *Federal Register* on June 10, 2002 (67 FR 39748) to keep the public informed of the evolving planning for a science mission to Pluto and the Kuiper Belt. The New Horizons mission, selected through a competitive process, is now proposed for launch in January – February 2006. The spacecraft would be launched on an expendable launch vehicle from Cape Canaveral Air Force Station, Florida. NASA's original baseline plan was modified to propose the use of a conventional radioisotope thermoelectric generator (RTG) instead of the RPS originally envisioned. The earlier Pluto-Kuiper Express mission also included several radioisotope heater units to maintain the temperature within the spacecraft. A conventional RTG would generate a greater amount of heat than a RPS. A combination of excess heat from the RTG, heat generated from electronics, heat from electrical heaters, and insulation would be utilized to maintain the thermal environment of the New Horizons spacecraft and would eliminate the need to carry radioisotope heater units, as originally envisioned.

The Information Update also reopened the scoping period, which closed on July 25, 2002. Comments were solicited from Federal, State and local organizations, and interested parties on the scope of the EIS. Scoping comments were received from 12 private organizations and 67 individuals. One of these organizations and three of these individuals had submitted comments in response to the original scoping period. Issues raised in the scoping comments included: (1) concern with the use of radioactive material for the spacecraft electrical power source; (2) use of alternative (radioactive and non-radioactive) sources for electrical power; (3) impacts to air quality due to launch vehicle exhaust; (4) global impacts in the event of a launch accident; and (5) concerns with the manufacturing and handling of the RTG.



Issues 1, 2, 3, and 4 were addressed in the Draft EIS (DEIS). Issues 1, 3, and 4 were summarized in Chapter 2 and discussed more thoroughly in Chapter 4. Issue 2 was addressed in Chapter 2. Comments associated with issue 5 have been addressed in existing environmental documentation prepared by the U.S. Department of Energy (DOE 1991, DOE 1999, DOE 2002b), which is responsible for the manufacturing and handling of RTGs.

## **1.5 RESULTS OF PUBLIC REVIEW OF THE DRAFT EIS**

NASA published a Notice of Availability (NOA) of the DEIS for the New Horizons mission on February 25, 2005 (70 FR 9387). The DEIS was mailed by NASA to 102 potentially interested Federal, State and local agencies, organizations and individuals. In addition, the DEIS was publicly available in electronic format on NASA's web site. NASA sent electronic mail (e-mail) notifications to 34 potentially interested individuals who had submitted scoping comments via e-mail but who had not provided a mailing address. The U.S. Environmental Protection Agency published its NOA for the DEIS on February 25, 2005 (70 FR 9306), initiating the 45-day review and comment period.

The public review and comment period closed on April 11, 2005. NASA received six comment submissions (letters and e-mails) from Federal, State and local agencies. No comment letters were received from private organizations, and three comment letters were received from private individuals. The comments received included "no comment" and requests for clarification of specific sections of text.

In addition, NASA received a total of 958 comment submissions via e-mail: two from private organizations and 956 from individuals. These comment submissions include objections to the use of nuclear material for space missions, a suggested alternative launch system and launch site for the proposed New Horizons mission, and general support for the proposed New Horizons mission.

All submissions received by NASA during the DEIS public review period are found in Appendix D of this FEIS, together with NASA's responses to specific comments.

In addition to soliciting comments for submittal by letter and e-mail, NASA held two meetings during which the public was invited to provide both oral and written comments on the New Horizons DEIS. The meetings were held on March 29 and 30, 2005, at the Florida Solar Energy Center in Cocoa, Florida. More information on these meetings, including transcripts of the public comments and NASA's responses, can be found in Appendix E of this FEIS.

This page intentionally left blank.

## 2 DESCRIPTION AND COMPARISON OF ALTERNATIVES

Pluto, the most distant planet in our solar system and the last to be discovered, has yet to be visited by a spacecraft. The proposed New Horizons mission would conduct the first survey of Pluto and would thus complete the initial reconnaissance of our solar system. The New Horizons spacecraft would fly by Pluto and its moon, Charon, and use remote sensing instrumentation to characterize the physical and chemical properties of these bodies. Following the Pluto-Charon encounter, the New Horizons spacecraft could be directed to fly by and observe one or more Kuiper Belt Objects (KBO).

This Final Environmental Impact Statement (FEIS) for the New Horizons mission evaluates the Proposed Action and the No Action Alternative.

- Proposed Action (NASA's Preferred Alternative)—The National Aeronautics and Space Administration (NASA) proposes to continue preparations for and implement the New Horizons mission to Pluto, its moon Charon, and possibly one or more objects within the Kuiper Belt. The New Horizons spacecraft would be launched on board an Atlas V 551 expendable launch vehicle from Cape Canaveral Air Force Station (CCAFS), Florida, during January – February 2006, and would be inserted into a trajectory toward Pluto. The spacecraft would arrive at the Pluto-Charon system as early as 2015, depending on the exact launch date, and would remotely gather scientific data during the flyby encounter. The spacecraft may then be directed on an extended mission to one or more KBOs.

In the event NASA is unable to launch the New Horizons spacecraft during the primary January – February 2006 opportunity, a backup opportunity could occur during February 2007. For this backup opportunity, arrival at Pluto would occur in either 2019 or 2020 depending on the exact launch date.

A description of the New Horizons mission is presented in Section 2.1.

- No Action Alternative—Under this alternative, NASA would discontinue preparations for the New Horizons mission and the spacecraft would not be launched. There would be no close reconnaissance of Pluto, Charon, or any KBO within the timeframe of the Proposed Action. Potential advancements in science resulting from this mission would not be realized. Continuing observations of Pluto, Charon, and the KBOs would be limited to those obtained only from existing ground-based and Earth-orbiting resources.

A description of the No Action Alternative is presented in Section 2.2.

### 2.1 DESCRIPTION OF THE PROPOSED ACTION

#### 2.1.1 Mission Description

The material presented in this section is summarized from *New Horizons Pluto-Kuiper Belt Mission and System Description* (APL 2003d).

The New Horizons spacecraft would be launched from CCAFS, Florida, on board an Atlas V 551 (hereinafter referred to as the Atlas V) expendable launch vehicle from Space Launch Complex 41 (SLC-41). During the primary launch opportunity of January 11 through February 14, 2006, launch dates between January 11 and February 2 allow use of a Jupiter Gravity Assist (JGA) maneuver to minimize the flight time to Pluto. The early dates (January 11 – January 27) during this opportunity yield an arrival at Pluto in 2015. Figure 2-1 depicts the baseline (preferred) mission trajectory for a launch in early January 2006. Launch dates in late January and early February yield arrival dates in 2016 and 2017, respectively. After February 2, 2006, Jupiter would no longer be in a position to provide a gravity assist, and only direct trajectories to Pluto would be available. For these direct trajectories, arrival at Pluto would range from 2018 through 2020, depending on the exact launch date in February 2006.

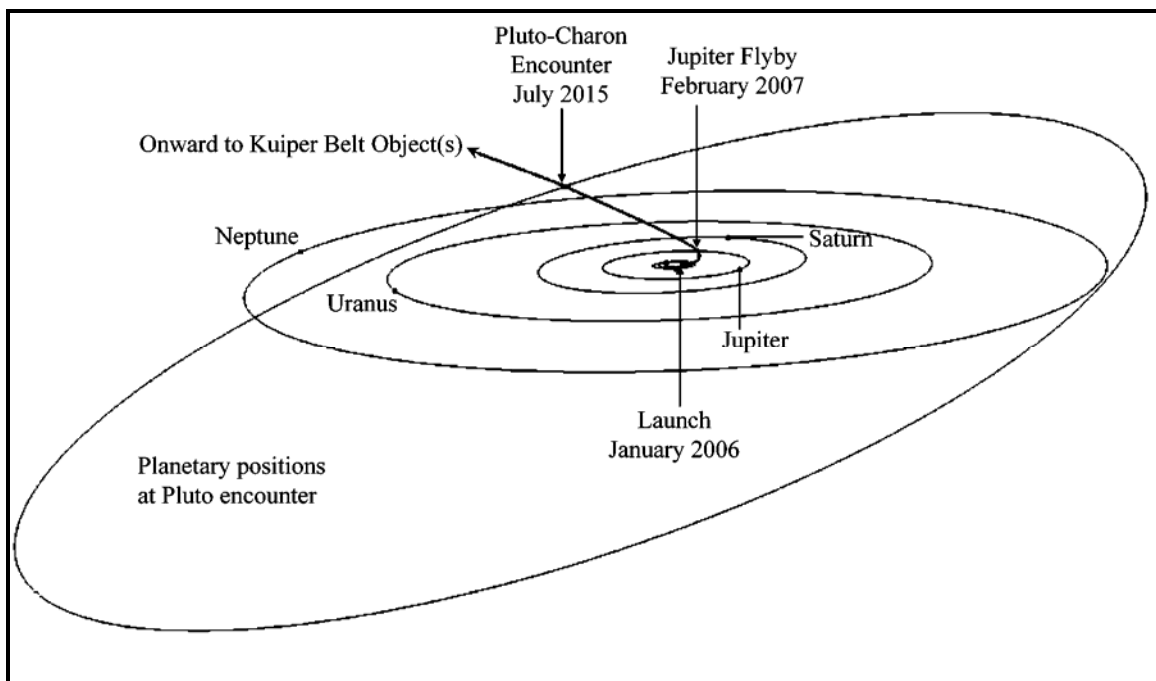

Source: APL 2003d

**FIGURE 2-1. THE NEW HORIZONS 2006 JUPITER GRAVITY ASSIST TRAJECTORY**

The gravity assist maneuver at Jupiter would occur in February 2007 and would redirect the spacecraft to the desired Pluto flyby trajectory. The spacecraft would fly by Jupiter at a distance of about 2.3 million kilometers (km) (1.4 million miles (mi)), and would conduct science observations of Jupiter and its satellites during a 4-month period. The spacecraft would then be placed in a low-power operational mode, with occasional status checks during the cruise to Pluto.

The spacecraft's science instruments would be activated 6 months prior to closest approach to Pluto in preparation for the flyby. The science observation phase would begin about 3 months prior to the encounter. The relative flyby speed of the spacecraft through the Pluto-Charon system would be somewhat less than 50,000 kilometers per

hour (km/h) (31,000 miles per hour (mph)). The spacecraft's closest approach to Pluto would be about 11,000 km (6,835 mi) and, 14 minutes later, its closest approach to Charon would be about 26,700 km (16,590 mi). Figure 2-2 depicts the encounter geometry as the spacecraft passes through the Pluto-Charon system.

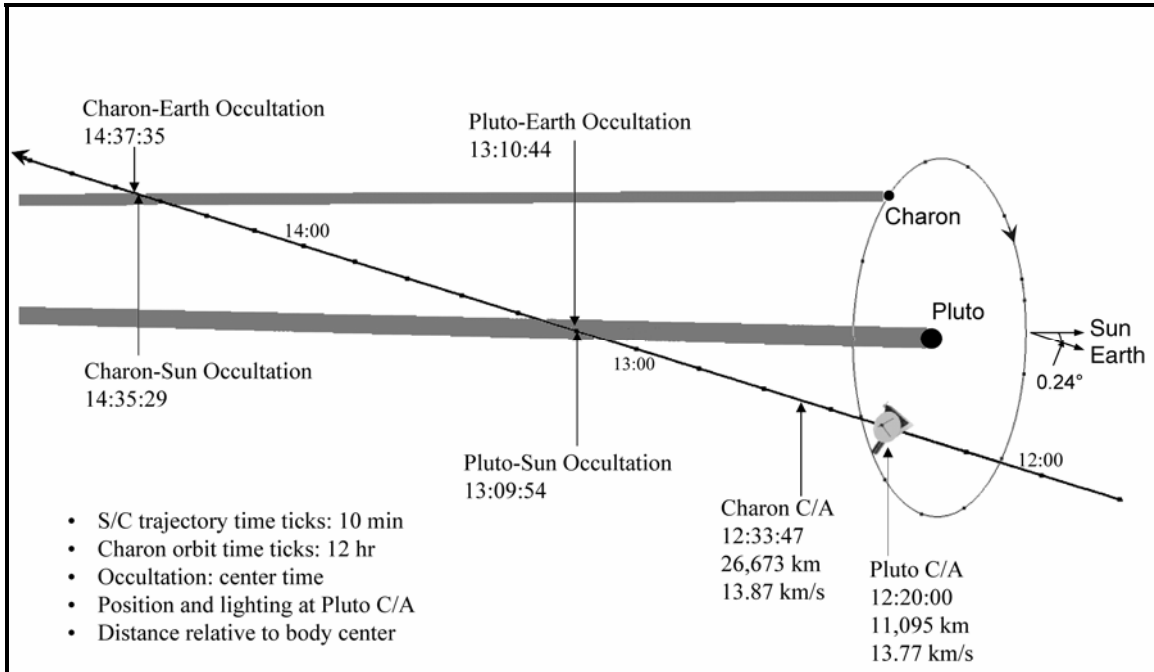

Source: APL 2003d

**FIGURE 2-2. NEW HORIZONS MISSION PLUTO-CHARON ENCOUNTER GEOMETRY**

Science observations and data gathering activities would begin 90 days before closest approach and end 90 days after closest approach, with the most intense science activity occurring during the 24-hour period centered around closest approach. Activities would include imaging, visible and infrared spectral mapping, ultraviolet spectroscopy, in situ measurements of energetic particles, and radio science. During the half-hour prior to closest approach to Pluto and Charon, the spacecraft would image each body in both visible and infrared wavelengths. The highest resolution images of Pluto are expected to depict surface features of about 100 meters (m) (330 feet (ft)) in diameter. The spacecraft would observe the dark side of Pluto to detect haze in the atmosphere and search for possible rings and smaller satellites. The spacecraft would also perform solar occultation experiments as it passes Pluto and Charon. Data obtained about Pluto and Charon would be stored on board the spacecraft and transmitted to Earth starting about two weeks after the flyby. Data transmission would be completed about 9 months after the flyby.

After the data transmission is complete, the spacecraft could be redirected to one or more KBOs. It would take three to six years to reach the KBOs. Science observations similar to those performed at Pluto and Charon would be obtained at the KBOs and would be transmitted to Earth.

In the event NASA is unable to utilize the January – February 2006 launch opportunity to Pluto, NASA could use a backup launch opportunity in February 2007. This backup launch opportunity would involve a direct trajectory to Pluto, would use the Atlas V launch vehicle from CCAFS, and the New Horizons spacecraft would arrive at Pluto in 2019 or 2020, depending on the exact launch date.

### 2.1.2 Spacecraft Description

The material presented in this section is summarized from *New Horizons Pluto-Kuiper Belt Mission and System Description* (APL 2003d).

The New Horizons spacecraft (Figure 2-3), provided under contract to NASA by The Johns Hopkins University's Applied Physics Laboratory (APL), would be based on a triangular shaped structure constructed of aluminum honeycomb panels. The spacecraft would be approximately 2.2 m (7.2 ft) in height, 2.7 m (8.9 ft) in width, and 3.2 m (10.5 ft) in length, and would have a maximum design mass of about 465 kilograms (kg) (1,025 pounds (lb)). The spacecraft's major components would consist of the 2.1 m (6.9 ft) diameter high gain antenna (HGA), equipment platform, propulsion system, and the radioisotope thermoelectric generator (RTG). The RTG would be externally mounted at one end of the triangular structure and would provide electrical power for the spacecraft. A combination of excess heat from the RTG, heat generated from the electronics, electrical heaters, and insulation would be used to maintain the temperature within the spacecraft. The spacecraft propulsion system would consist of propellant tanks and thrusters, and would use a nominal propellant load of about 80 kg (176 lb) of hydrazine for trajectory and attitude control maneuvers.

The suite of science instruments planned for the New Horizons mission would consist of the Pluto Exploration Remote Sensing Instrument (PERSI), the Radio Science Experiment (REX), the Pluto Energetic Particle Spectrometer Science Investigation (PEPSSI)<sup>1</sup>, the Solar Wind Around Pluto (SWAP), and the Long Range Reconnaissance Imager (LORRI). Data obtained from these instruments would fulfill the science objectives discussed in Chapter 1. In addition to these science instruments, a student experiment called the Student Dust Counter (SDC) would be included as a part of the science payload on the New Horizons spacecraft. An overview of the function and purpose of each instrument is presented in Table 2-1.

### 2.1.3 Spacecraft Electrical Power

The proposed New Horizons spacecraft would use a General Purpose Heat Source (GPHS)-RTG, provided to NASA by the U.S. Department of Energy (DOE), as the source of electrical power for its engineering subsystems and science payload. A detailed discussion of the RTG is provided in Section 2.1.3.2.

---

<sup>1</sup> The PEPSSI instrument uses 1 nanocurie of americium-241 as a calibration source.

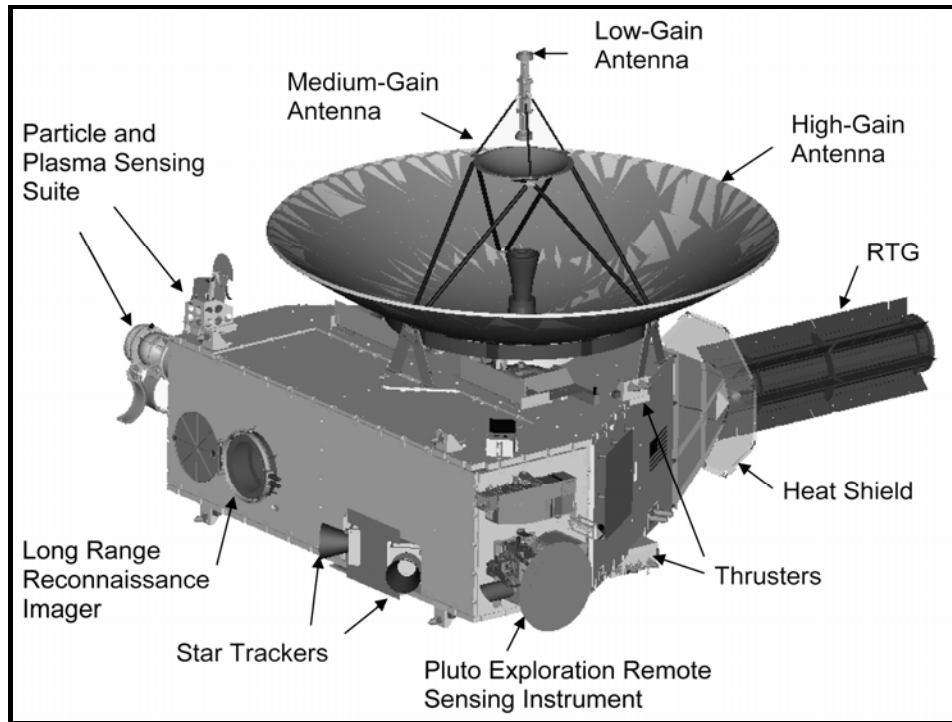

Source: APL 2003d

**FIGURE 2-3. MAJOR COMPONENTS OF THE NEW HORIZONS SPACECRAFT**

### 2.1.3.1 Electrical Power Performance Criteria

The New Horizons spacecraft's lengthy mission (nearly ten years to reach Pluto and another three to six years to reach one or more KBOs) would impose stringent performance criteria for its systems and components. The spacecraft would be subject to the radiation environment of Jupiter during the gravity-assist flyby. Further, the Pluto encounter would occur at a distance of about 33 astronomical units (AU) from the Sun, where solar illumination would be less than one-thousandth<sup>2</sup> of that encountered in Earth orbit. The flyby of the KBOs would occur at distances up to 50 AU from the Sun. Therefore, the electrical power system must satisfy a variety of performance and operational requirements, including but not limited to the following:

- operation during passage through Jupiter's radiation fields;
- provision of sufficient power at great distances from the Sun;
- a low mass-to-power ratio (high specific power); and,
- provision of a long-term source of electrical power with high reliability.

<sup>2</sup> The intensity of solar illumination is inversely proportional to the square of the distance from the Sun.

**TABLE 2-1. OVERVIEW OF THE FUNCTION AND PURPOSE OF THE NEW HORIZONS SCIENCE INSTRUMENTS**

<b>Instrument</b>	<b>Sensor</b>	<b>Function</b>	<b>Purpose</b>
PERSI—Pluto Exploration Remote Sensing Instrument	MVIC—Multispectral Visible Imaging Camera	<ul style="list-style-type: none"> <li>Obtain panchromatic and four-color images</li> <li>Perform optical navigation</li> </ul>	<ul style="list-style-type: none"> <li>Study geology and morphology of the surface</li> <li>Obtain geologic maps</li> </ul>
	LEISA—Linear Etalon Imaging Spectral Array	<ul style="list-style-type: none"> <li>Obtain high-resolution infrared spectral maps</li> <li>Map surface temperature</li> </ul>	<ul style="list-style-type: none"> <li>Identify composition of the surface</li> <li>Obtain temperature of the surface</li> </ul>
	ALICE—Ultraviolet Imaging Spectrometer	<ul style="list-style-type: none"> <li>Obtain ultraviolet spectra and spatial profiles</li> </ul>	<ul style="list-style-type: none"> <li>Study atmospheric structure and composition</li> </ul>
REX—Radio Science Experiment	Radio signal transmitter/receiver	<ul style="list-style-type: none"> <li>Perform uplink radio occultation experiment</li> <li>Measure surface brightness temperature</li> </ul>	<ul style="list-style-type: none"> <li>Measure temperature of the atmosphere</li> <li>Measure pressure profiles down to the surface</li> <li>Measure density of the ionosphere</li> <li>Search for an atmosphere around Charon</li> <li>Refine physical parameters</li> </ul>
Particle and Plasma Sensing Suite	Plasma and high-energy particle spectrometer	<ul style="list-style-type: none"> <li>Determine mass, energy spectra, directional distribution of energetic particles</li> </ul>	<ul style="list-style-type: none"> <li>Study escape rate of Pluto's atmosphere</li> </ul>
PEPSSI—Pluto Energetic Particle Spectrometer Science Investigation		<ul style="list-style-type: none"> <li>Provide low-resolution, supporting measurements of the solar wind flux</li> </ul>	<ul style="list-style-type: none"> <li>Study source and nature of energetic particles and plasmas</li> </ul>
SWAP—Solar Wind Analyzer		<ul style="list-style-type: none"> <li>Measure solar wind speed and density</li> </ul>	<ul style="list-style-type: none"> <li>Study ionosphere and solar wind interactions and bow shock</li> </ul>
LORRI—Long Range Reconnaissance Imager	Long-focal-length telescope/camera	<ul style="list-style-type: none"> <li>Provide high-resolution panchromatic images</li> </ul>	<ul style="list-style-type: none"> <li>Study geologic shapes and processes</li> </ul>
SDC—Student Dust Counter		<ul style="list-style-type: none"> <li>Detect dust grains</li> </ul>	<ul style="list-style-type: none"> <li>Measure concentration of dust particles in the outer solar system</li> </ul>

Source: APL 2003d



To fulfill these requirements, an analysis of available electrical power systems was done to find a power source sufficiently capable of meeting the performance and operational requirements for the proposed New Horizons mission (APL 2003a). (See Section 2.3.1 below for a discussion of the alternative power systems evaluated.) The GPHS-RTG was identified as the only feasible power system with the physical and operational characteristics capable of providing the necessary power to achieve the mission. Previous performance and implementation criteria for other deep space missions have also identified radioisotope power sources as the only suitable power system, as was the case for the Galileo, Ulysses, and Cassini missions (NASA 1989, NASA 1990, NASA 1995a).

### 2.1.3.2 The Radioisotope Thermoelectric Generator

An RTG converts heat from the radioactive decay of plutonium (in a ceramic form called plutonium dioxide ( $\text{PuO}_2$ ) consisting mostly of plutonium-238) into usable electrical power. RTGs were used on 25 previously-flown United States space missions (Table 2-2), including six Apollo flights, Pioneer, Viking, Voyager, Galileo, Ulysses, and Cassini. Radioisotope power source technology development has resulted in several models of an RTG, evolving from the Systems for Nuclear Auxiliary Power (SNAP)-RTG to the Multi-Hundred Watt (MHW)-RTG and the GPHS-RTG (Figure 2-4). The GPHS technology is the culmination of over 35 years of design evolution.

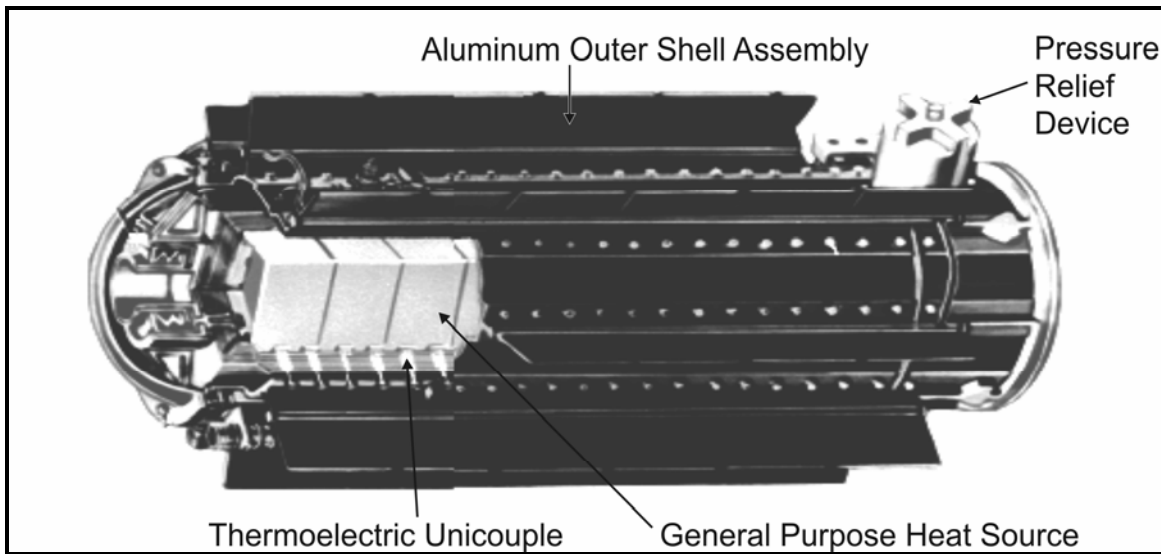

Source: DOE

**FIGURE 2-4. ILLUSTRATION OF A RADIOISOTOPE THERMOELECTRIC GENERATOR**

The GPHS-RTG (hereinafter referred to as the RTG) has a mass of about 56 kg (123.5 lb) and is 1.1 m (3.7 ft) long and 0.4 m (1.4 ft) in diameter. The RTG that would be used for the New Horizons mission would provide a minimum of 180 watts of electrical power at the time of the Pluto-Charon flyby, should the encounter occur in July 2015 (APL 2003d). The major components of the RTG consist of a thermoelectric

**TABLE 2-2. UNITED STATES SPACE MISSIONS INVOLVING RADIOISOTOPE POWER SOURCES**

Power Source (number of RTGs)	Spacecraft	Mission Type	Launch Date	Status	Activity at Launch (curies)
SNAP-3B7 (1)	TRANSIT 4A	Navigational	Jun 29, 1961	Currently in Earth orbit	1,500 – 1,600
SNAP-3B8 (1)	TRANSIT 4B	Navigational	Nov 15, 1961	Currently in Earth orbit	1,500 – 1,600
SNAP-9A (1)	TRANSIT 5BN-1	Navigational	Sep 28, 1963	Currently in Earth orbit	17,000
SNAP-9A (1)	TRANSIT 5BN-2	Navigational	Dec 5, 1963	Currently in Earth orbit	17,000
SNAP-9A (1)	TRANSIT 5BN-3	Navigational	Apr 21, 1964	Mission aborted; burned up on reentry as designed	17,000
SNAP-19B2 (2)	NIMBUS-B-1	Meteorological	May 18, 1968	Mission aborted; power source retrieved intact	34,400
SNAP-19B2 (2)	NIMBUS III	Meteorological	Apr 14, 1969	Currently in Earth orbit	37,000
SNAP-27 (1)	APOLLO 12	Lunar	Nov 14, 1969	ALSEP <sup>(a)</sup> shut down and remains on lunar surface	44,500
SNAP-27 (1)	APOLLO 13	Lunar	Apr 11, 1970	Mission aborted on way to moon; ALSEP power source fell into the Tonga Trench in the Pacific Ocean	44,500
SNAP-27 (1)	APOLLO 14	Lunar	Jan 31, 1971	ALSEP shut down and remains on lunar surface	44,500
SNAP-27 (1)	APOLLO 15	Lunar	Jul 26, 1971	ALSEP shut down and remains on lunar surface	44,500
SNAP-19 (4)	PIONEER 10	Planetary	Mar 2, 1972	Successfully operated to Jupiter and beyond	80,000
SNAP-27 (1)	APOLLO 16	Lunar	Apr 16, 1972	ALSEP shut down and remains on lunar surface	44,500
TRANSIT-RTG (1)	TRIAD-01-1X	Navigational	Sep 2, 1972	Currently in Earth orbit	24,000
SNAP-27 (1)	APOLLO 17	Lunar	Dec 7, 1972	ALSEP shut down and remains on lunar surface	44,500
SNAP-19 (4)	PIONEER 11	Planetary	Apr 5, 1973	Successfully operated to Jupiter, Saturn and beyond	80,000
SNAP-19 (2)	VIKING 1	Planetary	Aug 20, 1975	Lander shut down and remains on surface of Mars	41,000
SNAP-19 (2)	VIKING 2	Planetary	Sep 9, 1975	Lander shut down and remains on surface of Mars	41,000
MHW-RTG (2)	LES 8	Communications	Mar 14, 1976	Currently in Earth orbit	159,400
MHW-RTG (2)	LES 9	Communications	Mar 14, 1976	Currently in Earth orbit	159,400
MHW-RTG (3)	VOYAGER 2	Planetary	Aug 20, 1977	Successfully operated to Neptune and beyond	240,000
MHW-RTG (3)	VOYAGER 1	Planetary	Sep 5, 1977	Successfully operated to Saturn and beyond	240,000
GPHS-RTG (2)	GALILEO	Planetary	Oct 18, 1989	Successfully operated in Jupiter orbit; after 8 years, spacecraft purposefully entered Jupiter's atmosphere	269,000 <sup>(b)</sup>
GPHS-RTG (1)	ULYSSES	Planetary	Oct 6, 1990	Successfully operating in heliocentric flight	132,500
GPHS-RTG (3)	CASSINI	Planetary	Oct 15, 1997	Successfully operating in Saturn orbit	404,000 <sup>(b)</sup>

(a) Apollo Lunar Surface Experiments Package.

(b) Includes inventory from radioisotope heater units.

Note: The proposed New Horizons mission would use one GPHS-RTG with approximately 107,600 to 115,000 curies.

converter and a series of stacked GPHS aeroshell modules. The thermoelectric converter consists of an aluminum outer shell assembly, the axial and mid-span heat source supports, the thermoelectric elements, an insulation packet, and a gas management system. The thermoelectric converter contains silicon-germanium thermoelectric unicouples (Figure 2-4), which convert decay heat from the plutonium (in the form of  $\text{PuO}_2$ ) directly into electricity. The unicouples are surrounded by insulation to reduce thermal losses. The converter provides the support structure for the thermoelectric elements as well as for the aeroshell modules.

The RTG consists of a stacked column of 18 aeroshell modules. Each aeroshell module (Figure 2-5) contains about 0.6 kg (1.3 lb) of  $\text{PuO}_2$ . An aeroshell module consists of a graphite aeroshell, two carbon-bonded carbon fiber insulator sleeves, two graphite impact shells (GIS), and four iridium clads, each of which contains ceramic pellets of  $\text{PuO}_2$ . The graphite (carbon-carbon composite) aeroshell has a nominal operating temperature in space of 1,060 degrees Celsius ( $^{\circ}\text{C}$ ) (1,940 degrees Fahrenheit ( $^{\circ}\text{F}$ )) at the aeroshell surface (DOE 1990). The total radiological inventory for a typical RTG is 10.9 kg (24.0 lb) of  $\text{PuO}_2$  with a total activity of about 132,500 curies (Ci). Plutonium (Pu) can exist in a number of different radioactive isotopic forms. The principal plutonium isotope in the fuel is Pu-238 in terms of mass and activity. Table 2-3 provides representative characteristics and the isotopic composition of the  $\text{PuO}_2$ . Plutonium dioxide has a density of 9.6 grams per cubic centimeter (5.5 ounces per cubic inch), melts at  $2,400^{\circ}\text{C}$  ( $4,352^{\circ}\text{F}$ ), and boils at  $3,870^{\circ}\text{C}$  ( $6,998^{\circ}\text{F}$ ) (DOE 1990).

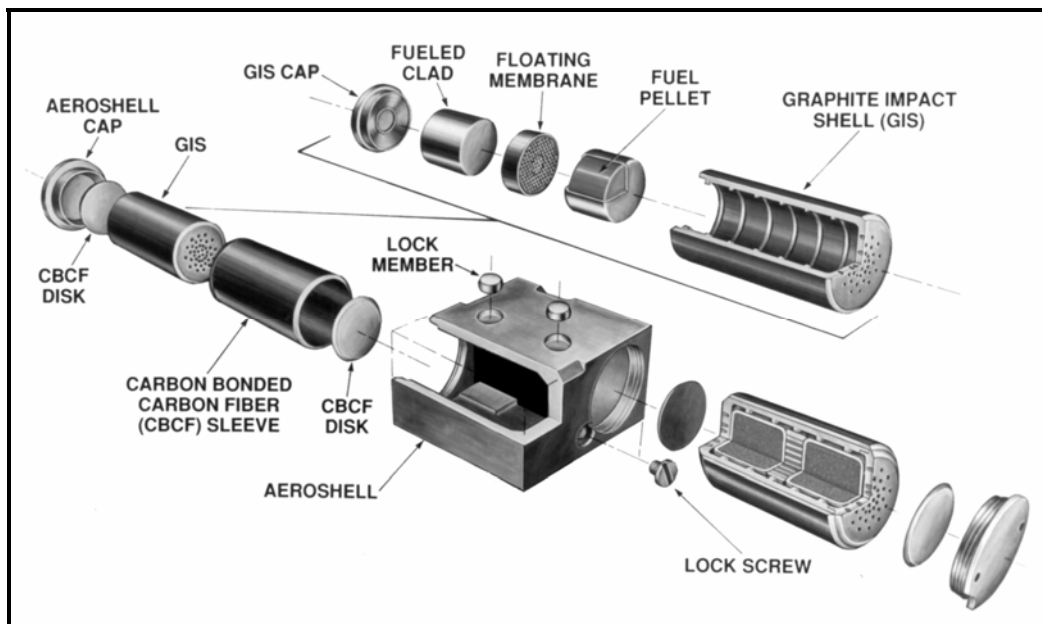

Source: DOE

**FIGURE 2-5. DIAGRAM OF A GENERAL PURPOSE HEAT SOURCE AEROSHELL MODULE**

**TABLE 2-3. TYPICAL ISOTOPIC COMPOSITION OF AN RTG**

Fuel Component	Weight Percent <sup>(a)</sup>	Half-Life, years	Specific Activity, curies/gram of Fuel Component	Total Activity, curies
Plutonium	83.63			
Pu-236	0.0000011	2.851	531.3	0.637
Pu-238	69.294	87.7	17.12	129,308
Pu-239	12.230	24,131	0.0620	82.65
Pu-240	1.739	6,569	0.2267	42.97
Pu-241	0.270	14.4	103.0	3,031
Pu-242	0.0955	375,800	0.00393	0.0409
Actinide Impurities	4.518	NA	NA	NA
Oxygen	11.852	NA	NA	NA
<b>Total</b>	<b>100.00</b>	<b>NA</b>	<b>NA</b>	<b>132,465</b>

Source: DOE 2005

(a) Based on 10.9 kg (24.0 lbs) of PuO<sub>2</sub> fuel.

NA = Not Applicable

The U.S. Department of Energy (DOE) designed the RTG to provide for containment of the PuO<sub>2</sub> fuel to the extent feasible during all mission phases, including ground handling, launch, and unplanned events such as reentry, impact, and post-impact situations (Bennett 1981). Under normal, accident, and post-accident conditions the safety-related design features of the RTG to be used for the New Horizons mission are intended to:

- minimize the release and dispersion of the PuO<sub>2</sub> fuel, especially of biologically significant small respirable particles;
- minimize land, ocean and atmosphere contamination, particularly in populated areas; and,
- maximize long-term immobilization of the PuO<sub>2</sub> fuel following postulated accidents.

Safety design features of the RTG include the following.

- Thermoelectric Converter: The RTG is designed to release the individual aeroshell modules in case of inadvertent reentry in order to minimize module terminal velocity and the potential for fuel release on Earth impact. The converter uses an aluminum alloy to ensure melting and breakup of the converter upon reentry, resulting in release of the modules.
- Aeroshell Module, GIS and related graphite components: The GPHS aeroshell module is composed of a three-dimensional carbon-carbon Fine Weave Pierced Fabric, developed originally for reentry nose cone material. The module and its graphite components are designed to provide reentry and surface impact

protection to the iridium fueled clad in case of accidental sub-orbital or orbital reentry. The aeroshell has been recently modified to include additional graphite material between the GISs and strengthens the module to enhance its performance under impact and reentry conditions.

- Iridium Fueled Clads: The iridium clad material is chemically compatible with the graphite components of the aeroshell module and the PuO<sub>2</sub> fuel over the operating temperature range of the RTG. The iridium has a high melting temperature (2,454°C (4,450°F)) and exhibits excellent impact response.
- PuO<sub>2</sub> Fuel: The fuel has a high melting temperature (2,400°C) (4,352°F), is very insoluble in water, and fractures into largely non-respirable chunks upon impact.

Formal safety tests of RTG components have established a data base that allows prediction of how these components would respond in accident environments. These safety tests have covered responses to the following environments:

- explosion overpressure;
- impact from fragments;
- other mechanical impact;
- thermal energy; and
- reentry conditions.

DOE has over 20 years experience in the engineering, fabrication, safety testing, and evaluation of GPHS aeroshell modules, building on the experience gained from previous heat source development programs and an information base that has grown since the 1950s. Test results have demonstrated the performance of the current design (LMMS 1997).

#### 2.1.4 Space Launch Complex-41

SLC-41 is located on a 19-hectare (47-acre) site in the southernmost section of Kennedy Space Center (KSC). NASA has permitted CCAFS to use SLC-41 and the surrounding land. The launch complex consists of a launch pad, an umbilical mast, propellant and water storage areas, an exhaust flume, catch basins, security services, fences, support buildings, and facilities necessary to prepare, service, and launch Atlas V expendable launch vehicles (USAF 1998, LMILS 2001). SLC-41 was previously used to launch Titan vehicles and was modified to accommodate the Atlas V.

Security at SLC-41 is ensured by a perimeter fence, guards, and restricted access. Since all operations in the launch complex would involve or would be conducted in the vicinity of liquid or solid propellants and explosive devices, the number of personnel permitted in the area, safety clothing to be worn, the type of activity permitted, and equipment allowed would be strictly regulated. The airspace over the launch complex would be restricted at the time of launch (LMILS 2001).

### 2.1.5 Spacecraft Processing

The New Horizons spacecraft would be designed, fabricated, integrated and tested at APL's facilities in Laurel, Maryland. These facilities have been used extensively in the past for a broad variety of spacecraft, and no new facilities would be required for the New Horizons spacecraft. APL would deliver the spacecraft to KSC for further testing and integration with the RTG and the third stage.

The spacecraft would be received at the KSC Payload Hazardous Servicing Facility (PHSF). The spacecraft would be inspected and comprehensive tests would be performed, including flight and mission simulations. The RTG would be delivered by DOE and stored at the KSC RTG storage facility. Once the spacecraft checks are completed, the RTG would be moved from the RTG storage facility to the PHSF where it would be fitted to the spacecraft for a pre-flight systems check. After completing these checks, the RTG would be moved back to the RTG storage facility. The spacecraft would then be fueled with about 80 kg (176 lb) of hydrazine, the nominal propellant load required for the primary New Horizons mission (APL 2003d).

The third stage would also be received at the PHSF, where it would be inspected and attached to the spacecraft. A systems check and spin test would then be performed, after which the spacecraft and third stage would be enclosed within the launch vehicle payload fairing (PLF). The PLF, containing the spacecraft and third stage, would then be transported from the PHSF to the Atlas V Vertical Integration Facility (VIF) at CCAFS and would be attached to the Atlas V Centaur second stage. The aft end of the PLF would be sealed with a barrier and connected to an environmental control system to prevent contamination during transit. Transportation of the PLF from KSC to CCAFS would be by truck, limited to a speed of 8 km/h (5 mph).

Once the launch vehicle integration is completed, the RTG would be transported from the KSC RTG Facility to the CCAFS VIF where it would be installed on the spacecraft. The Atlas V launch vehicle would then be moved from the VIF to the launch pad at SLC-41.

RTG handling at KSC and CCAFS would be performed under stringent conditions following all requirements governing the use of radioactive materials. Transportation of the RTG between KSC and CCAFS would be by truck, limited to a speed of 40 km/h (25 mph), and performed in accordance with applicable U.S. Department of Transportation and other Federal, State, and local regulations (NASA 2001).

### 2.1.6 Description of the Atlas V Launch Vehicle

NASA maintains a contractual mechanism, the National Launch Services (NLS) contract, with all United States providers of major launch vehicle services. Early in the development process for the proposed New Horizons mission, NASA released a Request for Launch Services Proposal (RLSP) that contained a statement of work and requested that proposals be submitted to NASA for the New Horizons mission. NASA received proposals that included configurations of the Delta IV and Atlas V launch vehicles from the NLS contract holders. A NASA technical evaluation team evaluated these proposals against the evaluation criteria stated in the RLSP, including technical

ability to meet the statement of work, ability to meet mission schedule, minimization of mission risk, past performance and flight history, expected launch vehicle availability, and cost/price. Upon completion of the evaluation, NASA determined that the proposal submitted by Lockheed Martin International Launch Services (LMILS) for the Atlas V 551 launch vehicle met all the specified mission requirements and was judged to present the best value to the government. LMILS was therefore awarded the launch service to provide the launch vehicle for the New Horizons mission.

The Atlas family of launch vehicles has evolved through various government and commercial programs from the first research and development flight in 1957 through the Atlas II, III, and V configurations. Versions of Atlas vehicles have been built specifically for both robotic and human space missions. The most recent version, the Atlas V, is currently available in 400 and 500 series configurations.

The Atlas V 551 launch configuration for the proposed New Horizons mission, depicted in Figure 2-6, would consist of a liquid propellant first stage, five strap-on solid rocket boosters (SRB), a liquid propellant Centaur second stage, a solid propellant third stage (procured separately from the launch vehicle contract by APL, the spacecraft provider), the New Horizons spacecraft, and the PLF. The "551" designation denotes a 5-m diameter PLF, five SRBs, and a single-engine Centaur. The SRBs are attached to the first stage, and the Centaur is mounted atop the first stage. The third stage, including the New Horizons spacecraft, would be mounted atop the Centaur. The PLF encloses and protects the third stage and the spacecraft.

Should the February 2007 backup launch opportunity be required, the launch vehicle would be nearly identical to the launch vehicle used for the January – February 2006 launch opportunity.

#### 2.1.6.1 First Stage

The Atlas V first stage is constructed mostly of aluminum and composite material, and is about 3.8 m (12.5 ft) in diameter and about 32.5 m (107 ft) in length. The first stage is powered by an RD-180 engine and contains about 284,089 kg (626,309 lb) of propellant. The fuel is rocket propellant-1 (RP-1), a

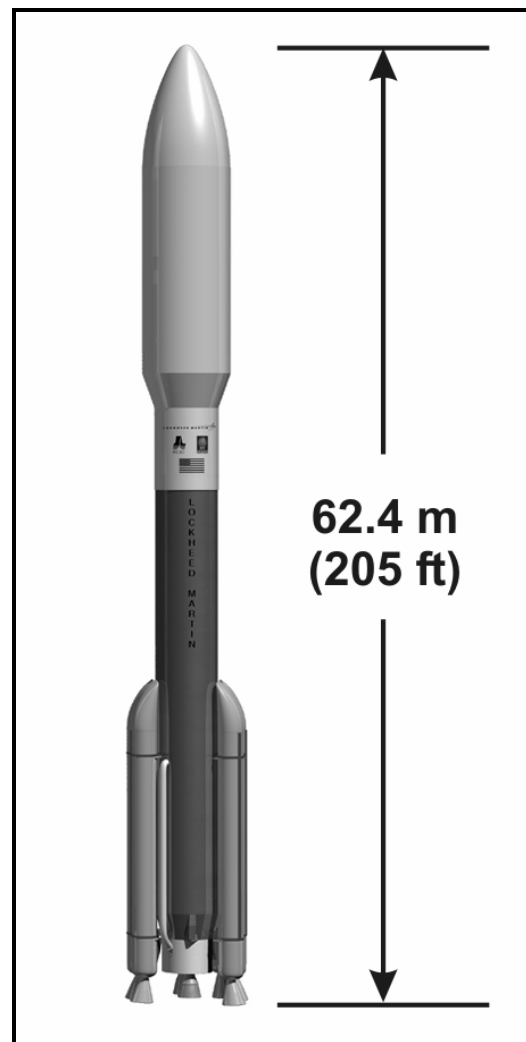

Source: Adapted from LMILS 2001

**FIGURE 2-6. ILLUSTRATION OF AN ATLAS V 551 LAUNCH VEHICLE**

thermally stable kerosene, and the oxidizer is liquid oxygen (LO<sub>2</sub>). Each SRB is about 1.5 m (5 ft) in diameter, about 20 m (66 ft) in length, and is fueled with about 42,412 kg (93,500 lb) of solid propellant (consisting of ammonium perchlorate, aluminum, and hydroxyl-terminated polybutadiene (HTPB) binder) for a total mass of about 212,060 kg (467,504 lb) for the five SRBs (LMILS 2001).

#### 2.1.6.2 Centaur Second Stage

The Atlas V Centaur second stage is constructed of stainless steel and is about 3.1 m (10 ft) in diameter and about 12.7 m (42 ft) in length. The Centaur is powered by a single, cryogenic RL10A-4-2 engine, and contains about 20,672 kg (45,573 lb) of propellant, consisting of liquid hydrogen (LH<sub>2</sub>) as the fuel and LO<sub>2</sub> as the oxidizer. The Centaur also uses about 127 kg (280 lb) of hydrazine for reaction control (USAF 1998).

#### 2.1.6.3 Third Stage

The Atlas V for the New Horizons mission would require use of a third stage to provide sufficient launch energy to insert the spacecraft on its trajectory to Pluto. Because a third stage is not a typical component of an Atlas V vehicle, the third stage for the New Horizons mission would be acquired separately from the launch vehicle. This third stage would consist of a STAR<sup>®</sup> 48B<sup>3</sup> solid rocket motor (SRM) with a spherical titanium case containing solid propellant and an exhaust nozzle, a spin table assembly, and a payload attach fitting. The STAR<sup>®</sup> 48B is about 1.2 m (4 ft) in diameter and about 2 m (6.7 ft) in length. The STAR<sup>®</sup> 48B motor contains about 2,009 kg (4,430 lb) of solid propellant (ammonium perchlorate, powdered aluminum, and HTPB). The third stage would use about 3 kg (6 lb) of hydrazine for spin control (APL 2003d).

#### 2.1.6.4 Payload Fairing

The PLF for the Atlas V is about 5.4 m (18 ft) in diameter and about 20.7 m (68 ft) in length and is constructed of aluminum, carbon fiber, and composite materials. The PLF encloses and protects the spacecraft from thermal, acoustic, electromagnetic, and environmental conditions during ground operations and lift-off through atmospheric ascent (LMILS 2001). Figure 2-7 depicts the New Horizons spacecraft and third stage within the PLF (APL 2003d).

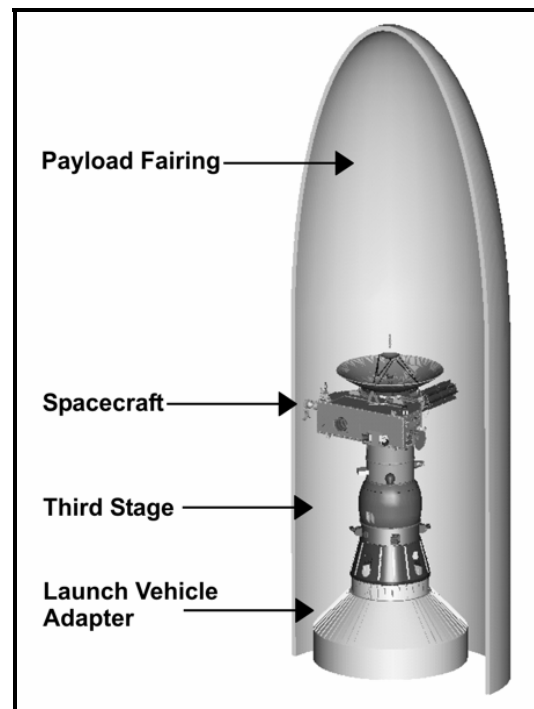

Source: APL 2003d

**FIGURE 2-7. ILLUSTRATION OF THE NEW HORIZONS ATLAS V PAYLOAD FAIRING**

<sup>3</sup> STAR<sup>®</sup> is a registered trademark of Alliant Techsystems Inc.



#### 2.1.6.5 Flight Termination System

As specified in the USAF's *Range Safety User Requirements Manual* (USAF 2004), Range Safety requires launch vehicles to be equipped with safety systems, collectively called the Flight Termination System (FTS), that are capable of causing destruction of the launch vehicle in the event of a major vehicle malfunction. Range Safety further specifies that for any launch vehicle the FTS reliability goal shall be a minimum of 0.999 at the 95 percent confidence level. The FTS for the New Horizons mission would provide the capability to destroy the Atlas V, if necessary, either (1) autonomously after detecting an inadvertent breakup of the vehicle or unintentional separation of vehicle stages, or (2) by commands issued via secure radio links. The FTS would consist of an Automatic Destruct System (ADS), a Centaur Automatic Destruct System (CADS), and a Command Destruct System (CDS).

If inadvertent vehicle breakup or premature stage separation occurs, the ADS would automatically initiate ordnance components that split open all first stage propellant tanks to disperse the liquid propellants and split all SRB casings to terminate solid motor thrusting. The CADS would automatically destruct the first and second stage propellant tanks and the SRBs, and activate two conical shaped charges to penetrate the aft dome of the third stage SRM to render it non-propulsive. Upon receipt of valid commands from Range Safety, the CDS would shut down the first stage or second stage main engines (depending on the timing of the event), and initiate destruction of the vehicle in the same manner as the CADS.

The CADS and CDS would also initiate the third stage SRM breakup system (BUS), an enhancement to the FTS for the New Horizons mission. The BUS adds two conical shaped charges mounted above the solid motor and directed into its upper dome. The purpose of the BUS would be to break up the large propellant dome into fragments to preclude an intact dome and attached spacecraft falling to the ground together, with potential for significant impact damage to the aeroshell modules.

The FTS would be armed 97 seconds before lift-off. Each major system of the FTS would be safed (automatically deactivated) at various times during the vehicle's ascent when the system would no longer be needed and to preclude its inadvertent activation. The BUS would be safed after the vehicle clears land and is over the Atlantic Ocean. The ADS and CADS would next be safed prior to separation of the first and second stages. Finally, the CDS would be safed immediately after completion of the first Centaur engine burn.

An Inadvertent Separation Destruct System (ISDS) would be incorporated on each of the five SRBs. In the event of an inadvertent or premature separation of an SRB, the ISDS would initiate a linear shaped charge to disable the SRB after a brief time delay to assure clearance from the Atlas V. The ISDS would be deactivated during a normal SRB separation event.

#### 2.1.6.6 Launch Vehicle Processing

Atlas launch vehicle preparation activities and procedures during and after launch have been previously documented (USAF 1998, LMILS 2001). All NASA launches follow the current standard operating procedures.

The Atlas V launch vehicle components for the New Horizons mission would be received at CCAFS, where they would be inspected, stored, and processed at appropriate facilities. When needed for launch, the components would be moved to the VIF, where the launch vehicle would be assembled, integrated, and tested. The PLF, containing the third stage and the New Horizons spacecraft, would then be attached to the top of the Centaur second stage. The Atlas V launch vehicle would then be moved via rail on a mobile launch platform, limited to a speed of 3.2 km/h (2 mph), to the launch pad at SLC-41 for a rehearsal of loading the RP-1, LO<sub>2</sub> and LH<sub>2</sub> liquid propellants, and then unloading the LO<sub>2</sub> and LH<sub>2</sub>. The vehicle (with RP-1) would then be moved back to the VIF, where hydrazine would be loaded and final vehicle processing would be performed. The RTG would then be installed on the spacecraft. The launch vehicle would then be moved back to the pad for LO<sub>2</sub> and LH<sub>2</sub> loading, final system tests, and launch (USAF 1998, USAF 2000, LMILS 2001).

Processing activities for the New Horizons Atlas V vehicle would be similar to those routinely practiced for other Atlas launches from CCAFS. Effluents and solid or hazardous wastes that may be generated by these activities are subject to Federal and State laws and regulations. NASA or its contractors would dispose of hazardous wastes. CCAFS has the necessary environmental permits and procedures for conducting launch vehicle processing activities (see Section 4.8).

#### 2.1.6.7 Launch Profile

Launch of the Atlas V would begin with the ignition of the first stage main engine followed approximately 3 seconds<sup>4</sup> later by ignition of the five SRBs (Figure 2-8). The SRB casings would be jettisoned after propellant burnout. The first stage main engine would continue to thrust and the PLF would be jettisoned. The main engine cutoff sequence would be initiated when low propellant levels are detected by the first stage propellant sensors (LMILS 2001). The first stage would then separate from the second and third stages. The SRB casings, the PLF, and the first stage would fall into the Atlantic Ocean in predetermined drop zones and would not be recovered (USAF 2000).

The Centaur second stage would be ignited shortly after separation from the first stage. Upon achieving Earth parking orbit, the Centaur engine thrust would be cut off via a timed command. After a brief, predetermined coast period in an Earth parking orbit, the Centaur engine would restart and the vehicle would accelerate to Earth escape velocity.

After separation from the Centaur, the third stage SRM would be ignited. The third stage would provide the final thrust needed to inject the New Horizons spacecraft onto the desired trajectory toward Pluto. After third stage motor cutoff, the New Horizons

---

<sup>4</sup> The engine undergoes an automatic "health check" during this period. Should a malfunction be detected, the engine would be shutdown and the launch would be aborted.

spacecraft would be separated and continue on its trajectory. The Centaur and the third stage would each continue separately into interplanetary space.

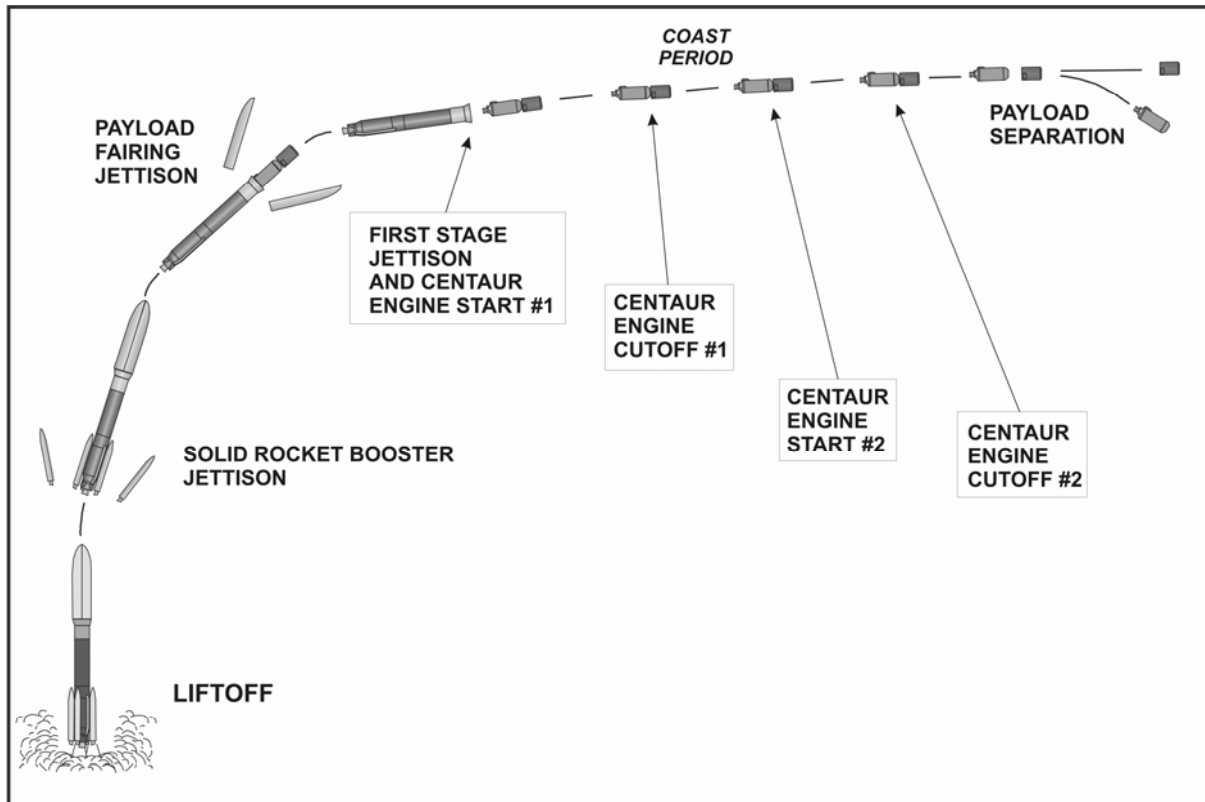

Source: Adapted from LMILS 2001

**FIGURE 2-8. TYPICAL ATLAS V ASCENT PROFILE**

### 2.1.7 Range Safety Considerations

CCAFS has implemented range safety requirements as specified in USAF 2004. For the New Horizons mission, predetermined flight safety limits would be established for each day of the launch period. Wind criteria, impacts from fragments that could be produced in a launch accident, dispersion and reaction (e.g., toxic plumes, fire) of liquid and solid propellants, human reaction time, data delay time, and other pertinent factors would be considered when determining the flight safety limits.

Models would be used to predict launch hazards to the public and on-site personnel prior to a launch. These models calculate the risk of injury resulting from toxic exhaust gases from normal launches, and from potentially toxic concentrations due to a failed launch. The launch could be postponed if the predicted collective risk of injury from exposure to toxic gases exceeds established limits (USAF 2004).

After lift-off, the Mission Flight Control Officer would take any necessary actions, including destruction of the vehicle via the CDS, if the vehicle's trajectory indicates flight anomalies (e.g., exceeding flight safety limits) (USAF 2004).

### 2.1.8 Electromagnetic Environment

Launch vehicles may be subject to electromagnetic conditions such as lightning, powerful electromagnetic transmissions (e.g., radar, radio transmitters), and charging effects (i.e., electrical charges generated by friction and the resultant electrostatic discharges). NASA and the USAF address such conditions with respect to the design of the launch vehicle, as well as with ordnance (e.g., explosives, explosive detonators and fuses), fuels, exposed surfaces of the vehicle, and critical electronic systems that must have highly reliable operations. A large body of technical literature exists on these subjects and has been used by NASA and the USAF in designing safeguards (see, for example, USAF 2004). The Atlas V, third stage, the New Horizons spacecraft, and the launch support systems would be designed and tested to withstand these environments in accordance with requirements specified in USAF 2004.

## **2.2 DESCRIPTION OF THE NO ACTION ALTERNATIVE**

Under the No Action Alternative, NASA would discontinue preparations for the New Horizons mission to Pluto. A flyby of the Pluto-Charon system or of any KBOs would not be conducted, and a unique opportunity for observing the atmosphere of Pluto would be missed. None of the close-up science investigations of Pluto, Charon, and any KBOs planned for the mission would be achieved. Observations of these bodies would remain limited to ground-based observatories or space-based observatories such as the Hubble Space Telescope.

## **2.3 ALTERNATIVES CONSIDERED BUT NOT EVALUATED FURTHER**

This section presents alternatives that were considered for the Proposed Action but were eliminated from further evaluation for the reasons discussed below. Evaluations were performed for alternative power sources and trajectories.

### 2.3.1 Alternative Power Sources

An electrical power generating system consists of an energy source and an energy conversion system. The available energy sources for a space mission include the Sun, chemicals in fuel cells or batteries, heat from radioactive decay, or the combustion of fuels. The energy conversion subsystem transforms energy into electricity using, for example, photovoltaic cells, thermoelectric couples, or dynamic conversion machinery.

For the proposed New Horizons mission, the power system used must satisfy the electrical power system performance requirements discussed in Section 2.1.3. Based on these requirements, alternative power sources to the RTG were evaluated that could potentially reduce or eliminate the environmental risks associated with the PuO<sub>2</sub> used in the RTG. The other power systems considered include those that: (1) replace the PuO<sub>2</sub> in the RTG with a potentially less hazardous radioisotope; (2) implement power system designs that require less PuO<sub>2</sub>; or (3) use a power system based on solar energy.

### 2.3.1.1 Other Radioisotope RTGs

The principal concern with using PuO<sub>2</sub> in RTGs is the potential radiation health and environmental hazards created if the PuO<sub>2</sub> is released into the environment following an accident. In principle, any radioisotope with a half-life long enough to provide sufficient power throughout the proposed New Horizons mission and with a high enough specific activity to provide the required power with a suitably small generator can be used. Two other radioisotopes possible for RTGs are the oxides of strontium-90 (Sr-90) and curium-244 (Cm-244). Sr-90 emits gamma radiation and Cm-244 emits both gamma and neutron radiation. PuO<sub>2</sub> emits much less gamma and neutron radiation than Sr-90 and Cm-244. Because gamma and neutron radiation are more penetrating than the alpha particles emitted by Pu-238, extensive shielding (not required with PuO<sub>2</sub>) would be required during production and handling, as well as onboard the spacecraft to protect sensitive components. In addition, extensive development and safety testing would also be required, and production facilities for sufficient quantities of these radioisotopes are not available. Therefore, Sr-90 and Cm-244 oxides cannot be considered as feasible isotopic heat sources for the New Horizons spacecraft's power system.

### 2.3.1.2 Power Systems Requiring Less Plutonium Dioxide

The GPHS-RTG using PuO<sub>2</sub> is a steady-state entity that provides continuous and quantifiable amounts of heat over its lifetime. As the Pu-238 in the fuel decays, the amount of heat decreases proportionately. For example, only half the amount of heat would be available at the half-life of the radioisotope (87.7 years). The RTG uses a thermocouple/unicouple conversion mechanism, a technology used in previous missions, to convert heat energy emitted by the radioactive decay of PuO<sub>2</sub> into electricity. To reduce the amount of PuO<sub>2</sub> used for electrical power on the spacecraft, a more efficient conversion technology would need to be developed.

The thermoelectric converter on the RTG has an efficiency of at least 6.5 percent (LLMS 1997). Other conversion technologies considered include static systems (thermionic, thermophotovoltaic, and alkali metal thermoelectric converter and dynamic systems (such as the Stirling engine).

NASA, in cooperation with DOE, is currently developing new radioisotope power systems (RPS) (the Stirling Radioisotope Generator (SRG) and the Multi-Mission Radioisotope Thermoelectric Generator (MMRTG) (DOE 2002a)) for application to a variety of deep space missions. The MMRTG would use thermocouples to convert heat from GPHS aeroshell modules directly into electricity. The SRG would use a Stirling engine to convert heat into mechanical energy, which in turn would be converted into electricity. The development and testing processes for both new systems would not result in an RPS that would be fully qualified and available by 2006 for the proposed New Horizons mission or for the 2007 backup opportunity. The first potential application of either the MMRTG or the SRG is not planned until 2009, beyond the timeframe of the Proposed Action.

The GPHS has a maximum operating temperature of 1,100°C (2,012°F). Thermionic converters are high-temperature systems operating at temperatures above 1,327°C (2,420°F), which make them incompatible with the GPHS. Thermophotovoltaic

converters operate at temperatures above 1,227°C (2,240°F), again making them incompatible with the GPHS. With appropriate filters and sufficient development time, however, thermophotovoltaic converters may operate at the limiting GPHS temperatures. Development of the alkali metal thermoelectric converter has been curtailed, and would require resolution of several issues, including performance, degradation, spacecraft integration, launch environments, lifetime, and zero gravity effects, before it could be considered for space applications.

All of these power systems have technology maturity or availability issues that cannot be resolved in a timeframe consistent with the proposed New Horizons mission requirements and, therefore, are not feasible and were not evaluated further.

### 2.3.1.3 Solar Energy Power Systems

The encounter with Pluto and Charon would occur at a distance of about 33 AU from the Sun, where the intensity of solar illumination is about one thousand times less than at the distance of Earth's orbit at 1 AU. Extending the mission to 50 AU within the Kuiper Belt further decreases the intensity of solar illumination. Current solar energy conversion technologies cannot provide adequate electrical power to operate and heat the New Horizons spacecraft at these distances from the Sun without a large solar array (on the order of 1,000 square meters (10,700 square feet) even with technology that concentrates solar illumination onto the array to increase its efficiency). The large mass and volume of such an array would preclude the mission's ability to perform the science investigations, even if the spacecraft could be launched. There would also be adverse consequences for the spacecraft design, including impacts to structure, attitude control, and pointing. The subsequent increase in the required power level to accommodate these adverse consequences would require a further increase in the array area (APL 2003a).

Therefore, a solar-powered mission to Pluto is not feasible and was not evaluated further.

## 2.3.2 Alternative Trajectories

### 2.3.2.1 Gravity Assist Trajectories

Alternative gravity assist trajectories to Pluto were examined that could reduce launch energy requirements for the proposed New Horizons mission, and thereby possibly eliminate the need for the solid rocket third stage (APL 2003b). Eliminating the third stage would eliminate the possibility (even with the BUS) that the intact stage and attached spacecraft could impact the ground together during a launch accident, and thus eliminate the potential for significant impact damage to the aeroshell modules should the BUS fail to activate.

The analysis focused on a class of trajectories called Delta-V Earth Gravity Assist ( $\Delta$ VEGA). After launch, a deep-space propulsive maneuver (designated Delta-V ( $\Delta$ V), for change in velocity) would be performed to place the spacecraft on a trajectory that would return to and fly by the Earth. As the spacecraft flies past Earth it would gain

additional momentum, enabling it to continue its journey toward the outer solar system. This gain in momentum is equivalent to using a more powerful launch vehicle to insert the spacecraft on a higher energy trajectory. The  $\Delta$ VEGA trajectories are further classified as 2+ years, 3+ years, and 4+ years, denoting the amount of time for the Earth flyby portion of the trajectory. In general, as the flight time to Earth flyby increases, the magnitude of the deep-space maneuver decreases (thus requiring less propellant onboard the spacecraft) but the launch energy requirement increases (thus requiring a more powerful launch vehicle).

Several  $\Delta$ VEGA trajectories to Pluto were examined with launch opportunities in January 2006 and January 2007 and with arrival at Pluto in 2015, 2016, and 2020. Jupiter would not be in position near the flight paths of these  $\Delta$ VEGA trajectories toward Pluto to provide an additional gravity assist. In all cases the flyby altitude at Earth was constrained to be 300 km (187 mi) since the lowest possible flyby altitude yields the highest possible momentum gain. Even at this low flyby altitude the Earth would not provide sufficient change in momentum for the spacecraft to reach Pluto. More energy would therefore need to be added to the trajectory by a propulsive maneuver (powered flyby) during the closest approach at Earth.

A large chemical propulsion system would need to be added to the baseline New Horizons spacecraft to accommodate the combination of the deep-space maneuver and the powered flyby at Earth. Except for two trajectories, the  $\Delta$ VEGA cases analyzed had combined  $\Delta V$  requirements that were judged to be too large to warrant further study. The two most efficient of the  $\Delta$ VEGA trajectories examined for the proposed New Horizons mission are the 3+ years and 4+ years trajectories launching in January 2006 and arriving at Pluto in 2020. These would have the lowest combined  $\Delta V$ : 3,012 meters per second (m/s) (9,882 feet per second (ft/s)) and 2,587 m/s (8,487 ft/s), respectively.

The size of a new propulsion system, which would be added to the baseline New Horizons spacecraft, was estimated for these two cases. The total mass at launch of the New Horizons spacecraft with this new propulsion system was estimated to be approximately 2,580 kg (5,690 lb) for the 2006 3+ years  $\Delta$ VEGA trajectory, and approximately 1,920 kg (4,235 lb) for the 2006 4+ years  $\Delta$ VEGA trajectory. Each mass is beyond the launch capability of the Atlas V without a solid rocket third stage, thus making elimination of the third stage not feasible.

#### 2.3.2.2 Low Thrust Trajectories

A low thrust trajectory requires the use of a propulsion system with a thrust acceleration level typically less than one ten-thousandth of the Earth's gravity, and with a specific impulse that is typically two orders of magnitude higher than that of a conventional high thrust chemical propulsion system. However, large-scale low thrust propulsion systems for deep-space mission applications are not yet available and would require significant development. Two types of low thrust propulsion systems were considered: solar-electric propulsion and nuclear-electric propulsion.

Solar-electric propulsion (SEP), the most mature and best understood of the two types of systems, would use large solar arrays to provide electrical power to a number of ion

thrusters that would typically use xenon as the propellant. A SEP system could operate efficiently only near the Sun, to solar distances not greater than about 4 AU. SEP low thrust trajectory alternatives to the proposed New Horizons mission were assessed (APL 2002). While examining several possible scenarios, the assessment focused on a solar-electric low thrust trajectory to Pluto that includes a Venus Gravity Assist. The launch for such a mission would occur in February 2008 with arrival at Pluto in 2019. For this mission scenario, the New Horizons spacecraft would be attached to a separate SEP module having an estimated mass of 1,125 kg (2,480 lb), including 560 kg (1,235 lb) of xenon propellant. The New Horizons spacecraft would need to be modified to accommodate the increased thermal environment near 0.7 AU during the Venus flyby. The SEP module would generate 15.3 kilowatts of electrical power at 1 AU, and would be jettisoned after reaching a distance of about 4 AU from the Sun, when solar energy diminishes below the level needed to maintain adequate power to the thrusters. Because the SEP module would be jettisoned, the New Horizons spacecraft would still require a separate chemical propulsion system for trajectory and attitude control maneuvers beyond 4 AU and a separate source, such as an RTG, for electrical power and heat. Therefore, a solar-electric low thrust trajectory alternative would offer no advantages to the proposed New Horizons mission, and was not evaluated further.

Nuclear-electric propulsion (NEP) would use a small nuclear reactor to provide electrical power to the ion thrusters. A NEP system would provide propulsive capability to and beyond Pluto and could provide electrical power and heat to a spacecraft. However, the major components of a NEP system still require significant development and testing, and would not be qualified in time for the proposed New Horizons mission. Therefore, a nuclear-electric low thrust trajectory alternative to the proposed New Horizons mission was not evaluated further.

## **2.4 COMPARISON OF ALTERNATIVES INCLUDING THE PROPOSED ACTION**

This section summarizes and compares the potential environmental impacts of the Proposed Action and the No Action Alternative. The anticipated impacts associated with nominal or normal implementation of the Proposed Action are considered first, followed by a summary and comparison of the potential radiological consequences and risks from an accident associated with the Proposed Action. No such impacts would be associated with the No Action Alternative. Details of the results summarized in this section can be found in Chapter 4.

### **2.4.1 Environmental Impacts of a Normal Launch**

Table 2-4 provides a summary comparison of the anticipated environmental impacts associated with normal implementation of the Proposed Action and the No Action Alternative.

Proposed Action. The environmental impacts associated with implementing the Proposed Action would center largely on the exhaust products emitted from the Atlas V launch vehicle's SRBs and the short-term impacts of those emissions. High concentrations of solid rocket motor exhaust products, principally aluminum oxide (Al<sub>2</sub>O<sub>3</sub>) particulates, carbon monoxide (CO), hydrogen chloride (HCl), nitrogen (N<sub>2</sub>), and



**TABLE 2-4. SUMMARY COMPARISON OF THE NEW HORIZONS MISSION ALTERNATIVES**

Impact Category	New Horizons Mission Alternatives	
	Normal Implementation of the Proposed Action	No Action
Land Use	No adverse impacts on non-launch-related land uses at CCAFS would be anticipated.	No change in baseline condition.
Air Quality	High levels of solid propellant combustion products could occur within the exhaust cloud. The exhaust cloud would rise and disperse near the launch complex. No long-term adverse air quality impacts would be anticipated in off-site areas.	No change in baseline condition.
Noise and Sonic Boom	Sound levels estimated at the nearest communities would be in the moderate range. Exposure levels are estimated to be within federal guidelines for affected workers and the public.	No change in baseline condition.
Geology and Soils	Some deposition of aluminum oxide particulates and hydrogen chloride near the launch complex would be anticipated.	No change in baseline condition.
Hydrology and Water Quality	Water used for pre-launch fire protection, heat suppression and acoustic damping during launch, and post-launch wash down would be collected and treated, if necessary, prior to being released to grade. A potential short-term increase in the acidity of nearby surface waters could occur following launch, however, no adverse long-term impacts to groundwater or surface waters would be anticipated.	No change in baseline condition.
Biological Resources	Biota in the launch complex could be damaged or killed during launch. Possible acidification of nearby surface waters could cause some mortality of aquatic biota. No long-term adverse effects would be anticipated. No short-term or long-term impacts to threatened or endangered species or to essential fish habitat would be anticipated.	No change in baseline condition.
Socioeconomics	No impacts would be anticipated.	No change in baseline condition.
Environmental Justice	No disproportionate impacts would be anticipated.	No change in baseline condition.
Cultural/Historical/Archaeological Resources	No impacts would be anticipated.	No change in baseline condition.
Global Environment	Not anticipated to adversely affect global climate. Temporary localized decrease in ozone would be anticipated along the flight path with rapid recovery to pre-launch conditions.	No change in baseline condition.

water (H<sub>2</sub>O), would occur in the exhaust cloud that would form at the launch complex. CO would be quickly oxidized to carbon dioxide (CO<sub>2</sub>), and N<sub>2</sub> may react with oxygen to form nitrogen oxides (NO<sub>x</sub>). Due to the relatively high gas temperatures, this exhaust cloud would be buoyant and would rise quickly and begin to disperse near the launch pad. High concentrations of HCl would not be expected, and long-term damage to vegetation and prolonged acidification of nearby water bodies should not occur. No adverse impacts to air quality in offsite areas would be expected.

If rain were to occur shortly after launch, some short-term acidification of nearby water bodies could occur with the accompanying potential for some mortality of aquatic biota. Biota that happened to be in the path of the exhaust could be damaged or killed. Threatened or endangered species would not be jeopardized nor would critical habitats be affected at CCAFS. As the launch vehicle gains altitude, a portion of the solid rocket motor exhaust (specifically HCl, Al<sub>2</sub>O<sub>3</sub>, and NO<sub>x</sub>) would be deposited in the stratosphere, resulting in a short-term reduction in ozone along the launch vehicle's flight path. Recovery, however, would be rapid.

Noise and sonic booms would be associated with the launch. However, neither launch site workers nor the public would be adversely affected. No impacts to cultural, historical or archaeological resources would be expected from the launch. The New Horizons mission launch would not be expected to disproportionately impact either minority or low-income populations.

No Action Alternative. Under the No Action Alternative, NASA would discontinue preparations for the New Horizons mission to Pluto, and the spacecraft would not be launched. Spacecraft and launch vehicle components would be recycled. Thus, none of the anticipated impacts associated with a normal launch would occur.

#### 2.4.2 Environmental Impacts of Potential Nonradiological Launch Accidents

Proposed Action. Nonradiological accidents could occur during preparation for and launch of the New Horizons spacecraft at CCAFS. The two nonradiological accidents of greatest concern would be a liquid propellant spill and a launch vehicle failure.

The potential for environmental consequences would be limited primarily to liquid propellant spills of RP-1, LH<sub>2</sub>, LO<sub>2</sub>, and hydrazine during fueling operations of the Atlas V, and a launch failure at or near the launch pad. USAF safety requirements (USAF 2004) specify detailed policies and procedures to be followed to ensure worker and public safety during liquid propellant fueling operations. Propellant spills or releases of RP-1, LH<sub>2</sub>, and LO<sub>2</sub> would be minimized through remotely operated actions that close applicable valves and safe the propellant loading system. Workers performing propellant loading (e.g., RP-1 and hydrazine) would be equipped with protective clothing and breathing apparatus and uninvolved workers would be excluded from the area during propellant loading. Propellant loading would occur only shortly before launch, further minimizing the potential for accidents.

A launch vehicle failure on or near the launch area during the first few seconds of flight could result in the release of the propellants (solid and liquid) onboard the Atlas V and the spacecraft. The resulting emissions would resemble those from a normal launch,

consisting principally of CO, CO<sub>2</sub>, HCl, NO<sub>x</sub>, and Al<sub>2</sub>O<sub>3</sub> from the combusted propellants. A launch vehicle failure would result in the prompt combustion of a portion of the liquid propellants, depending on the degree of mixing and ignition sources associated with the accident, and somewhat slower burning of the solid propellant fragments. Falling debris would be expected to land on or near the launch pad resulting in potential secondary ground-level explosions and localized fires. After the launch vehicle clears land, debris from an accident would be expected to fall over the ocean. Modeling of accident consequences with meteorological parameters that would result in the greatest concentrations of emissions over land areas indicates that the emissions would not reach levels threatening public health. Some burning solid and liquid propellants could enter surface water bodies and the ocean resulting in short-term, localized degradation of water quality and toxic conditions to aquatic life. Such chemicals entering the ocean would be rapidly dispersed and buffered, resulting in little long-term impact on water quality and resident biota.

No Action Alternative. Under the No Action Alternative a launch would not occur, therefore there would be no potential for either type of accident to occur.

### 2.4.3 Environmental Impacts of Potential Radiological Launch Accidents

This section presents a summary of the nuclear risk assessment (DOE 2005) performed for the Proposed Action described in this FEIS. A more detailed presentation can be found in Section 4.1.4.

As shown in Figure 2-9, the most likely outcome of implementing the New Horizons mission, about 94 percent probability, is a successful launch to Pluto. Should an accident occur during launch (about 6 percent probability), most such accidents would not result in environments that could damage the RTG and release some of the PuO<sub>2</sub>. About 0.4 percent of the time a launch accident could result in a release of PuO<sub>2</sub>, but not in a large enough quantity to result in discernible health consequences (see Section 2.4.3.2 below).

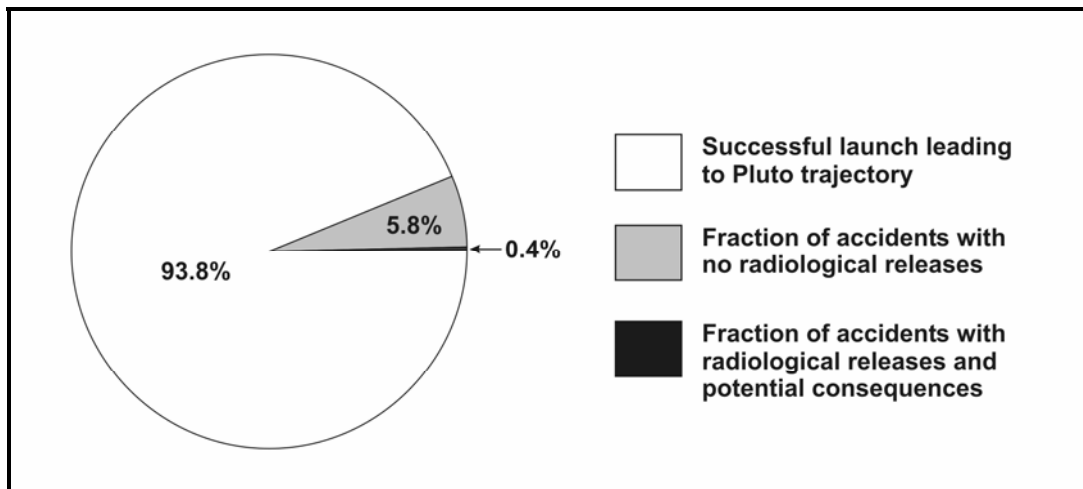

Source: Adapted from DOE 2005

**FIGURE 2-9. LAUNCH-RELATED PROBABILITIES**

NASA and DOE and its contractors have conducted several safety assessments of launching and operating spacecraft using RTGs (i.e., the Galileo mission in 1989, the Ulysses mission in 1990, and the Cassini mission in 1997). In developing the nuclear risk assessment for this FEIS, NASA and DOE have built upon an extensive experience base that involves:

- testing and analysis of the heat source modules and RTGs under simulated launch accident environments;
- evaluating the probability of launch-related accidents based on evaluations of launch histories, including extensive studies of the January 1997 Delta II accident at CCAFS, and system designs; and
- estimating the outcomes of the RTG responses to the launch accident environments.

Several technical issues that could impact the results presented in this DEIS are under continuing evaluation. These issues could not be fully addressed in the risk assessment; best engineering judgment was used to address these issues and their impact on the risk estimate for the New Horizons mission. The important issues that were addressed in this manner and that are the subject of continuing evaluation include:

- the severity of the solid propellant fire environment and its potential effect on the release of  $\text{PuO}_2$  from the RTG;
- the behavior of solid  $\text{PuO}_2$  and  $\text{PuO}_2$  vapor in the fire environment and the potential for  $\text{PuO}_2$  vapor to permeate the graphite components in the RTG; and,
- the release characteristics, under postulated accident conditions, of older  $\text{PuO}_2$  extracted from the spare RTG built for the Galileo mission.

Under Presidential Directive/National Security Council Memorandum 25 (PD/NSC-25), a separate nuclear launch safety review of the New Horizons mission is being conducted by NASA and DOE. As part of this process DOE, is preparing a Final Safety Analysis Report (FSAR) that will include a complete, detailed risk analysis. In preparing the FSAR, DOE is following procedures and using techniques similar to those used in the risk analyses performed for earlier NASA missions using radioisotope devices. An Interagency Nuclear Safety Review Panel (INSRP) has been formed for the New Horizons mission, and is reviewing this safety analysis. Should the FSAR present risk estimates that differ significantly from those presented in this EIS, NASA would consider the new information, and determine the need for additional environmental documentation.

#### 2.4.3.1 The EIS Nuclear Risk Assessment

The nuclear risk assessment for the New Horizons mission considers (1) potential accidents associated with the launch, and their probabilities and accident environments; (2) the response of the RTG to such accidents in terms of the amount of radioactive materials released and their probabilities; and (3) the radiological consequences and mission risks associated with such releases. The risk assessment was based on a

typical radioactive material inventory of 132,500 Ci of primarily plutonium-238 (an alpha-emitter with a half life of 87.7 years). The PuO<sub>2</sub> in the RTG to be used on the New Horizons spacecraft would consist of a mixture of fuel of differing ages, yet to be finalized. Based on the latest information, the inventory in the RTG is estimated to be in the range of 108,000 to 124,000 Ci. A reduction in the assumed inventory from 132,500 Ci would lead to an estimated proportional decrease in the results reported in DOE 2005 and summarized in this FEIS.

The risk assessment for the New Horizons mission began with the identification of the initial launch vehicle system malfunctions or failures and the subsequent chain of accident events that could ultimately lead to the accident environments (e.g., explosive overpressures, fragments, fire) that could threaten the RTG. These launch vehicle system failures were based on Atlas V system reliabilities and estimated failure probabilities (ASCA 2005).

Failure of the launch vehicle has the potential to create accident environments that could damage the RTG and result in the release of PuO<sub>2</sub>. Based on analyses performed for earlier missions that carried radioisotope devices (RTGs and radioisotope heater units), DOE identified the specific accident environments that could potentially threaten the RTG.

DOE determined the response of the RTG and RTG components to these accident environments and estimated the amount of radioactive material that could potentially be released. Results of DOE's RTG testing and analyses were used to determine if a release of PuO<sub>2</sub> from the RTG could potentially occur. The amount of PuO<sub>2</sub> that could be released to the environment was determined based upon scaling of selected results from previous missions and additional analyses, where appropriate, to reflect conditions specific to the Atlas V and the New Horizons mission. Several factors, including population growth, Atlas V specific dispersion (vertical plume) configurations, the launch complex location, the amount of PuO<sub>2</sub> in the mission, the amount of solid propellant and its configuration, and the physical characteristics of the released PuO<sub>2</sub> were considered.

For this risk assessment, the New Horizons mission was divided into mission phases which reflect principal launch events.

- Phase 0 (Pre-Launch) and Phase 1 (Early Launch): A launch-related accident during these periods could result in ground impact in the launch area with some release of PuO<sub>2</sub> from the RTG. The results for Phases 0 and 1 are discussed below in combination because both deal with accidents that could occur in and directly affect the launch area. The results presented are probability-weighted averages of the mean estimates for both Phases. Each Phase is discussed separately in more detail in Chapter 4.
- Phase 2 (Late Launch): A launch accident during this period would lead to impact of debris in the Atlantic Ocean with no release of PuO<sub>2</sub> since undamaged aeroshell modules would survive water impact at terminal velocity.

- Phase 3 (Pre-Orbit): A launch accident during this period prior to reaching Earth parking orbit could lead to prompt sub-orbital reentry within minutes. Breakup of the spacecraft during reentry could result in impacts of individual aeroshell modules along the vehicle flight path over the Atlantic Ocean and southern Africa. Should the aeroshell modules impact hard surfaces (e.g., rock), small releases of PuO<sub>2</sub> are possible at ground level.
- Phase 4 (Orbit): A launch accident which occurs after attaining parking orbit could result in orbital decay reentries from minutes to years after the accident, affecting Earth surfaces between approximately 28° North Latitude and 28° South Latitude. Post-reentry impact releases would be similar to those in Phase 3, except more aeroshell modules could impact hard surfaces due to differences in the probability of impact on hard surfaces within these latitude bands.
- Phase 5 (Escape): A launch accident which leads to Earth escape conditions would not result in a release of PuO<sub>2</sub>.

#### 2.4.3.2 Accident Consequences

The radiological consequences of a given accident that results in a release of radioactive material have been calculated in terms of maximum individual dose, collective dose, health effects, and land area contaminated at or above specified levels. The radiological consequences have been determined from atmospheric transport and dispersion simulations incorporating both worldwide and launch-site specific meteorological and population data. Biological effects models, based on methods prescribed by the National Council on Radiation Protection and Measurements (NCRP) and the International Commission on Radiological Protection (ICRP), were applied to predict the number of health effects following a New Horizons launch accident that results in a release of PuO<sub>2</sub>.

Risk estimates were generated for each mission phase by combining the probabilities and consequences for each relevant accident environment. The risk estimates for all mission phases were combined to produce an overall mission risk estimate.

The analyses conducted by DOE for this FEIS are described in greater detail in Chapter 4, with the results presented for both mean and 99-th percentile values. For the purposes of this summary, the accident consequences and associated risks are presented only in terms of the mean. The 99-th percentile value reflects the potential for higher radiological consequences to the exposed population at lower probabilities than could occur for all accidents involving a release to the environment. The 99-th percentile consequences are typically a factor of 5 to 15 higher but at probabilities 100 times lower than the mean consequences.

##### *Human Health Consequences*

Human health consequences are expressed in terms of maximum individual dose, collective dose to the potentially exposed population, and the associated health effects. The maximum individual dose is the maximum dose, expressed in units of rem,

delivered to a single individual for each accident. Collective dose is the sum of the radiation dose received by all individuals exposed to radiation from a given release, expressed in units of person-rem. Health effects represent statistically estimated additional latent cancer fatalities resulting from an exposure over a 50 year period to a release of radioactive material, and are determined using ICRP-60 health effects estimators (ICRP 1990). The estimated radiological consequences by mission phase and for the overall mission are summarized below.

Chapter 4 provides a detailed quantitative discussion of the accident probabilities for the New Horizons mission. For this summary discussion, the total probabilities of an accident with a release of PuO<sub>2</sub> are grouped into categories that allow for a descriptive characterization of the likelihood of each accident. The categories and their associated probability ranges are:

- unlikely: 10<sup>-2</sup> to 10<sup>-4</sup> (1 in 100 to 1 in 10 thousand);
- very unlikely: 10<sup>-4</sup> to 10<sup>-6</sup> (1 in 10 thousand to 1 in 1 million); and
- extremely unlikely: less than 10<sup>-6</sup> (less than 1 in 1 million).

Qualitatively, unlikely accidents are events that will probably not occur during this mission. Both the very unlikely and extremely unlikely accidents are highly improbable events that would probably not occur even during a series of several missions.

*Accidents Within the Launch Area (within 100 km (62 mi) of the launch site)*

- Phases 0 and 1 (Pre-Launch and Early Launch): Prior to launch, the most likely result of a launch vehicle problem would be a safe hold or termination of the launch. After lift-off, most significant launch vehicle problems would lead to the automatic or commanded activation of on-board safety systems resulting in destruction of the launch vehicle. For both Phases combined, the total probability of an accident resulting in a release is considered to be unlikely, about 1 in 620. The maximum dose received by an individual within the exposed population would vary and would have a mean value of about 0.3 rem, which is the equivalent of about 80 percent of the normal annual background dose received by each member of the U.S. population during a year<sup>5</sup>. The collective dose that would be received by all individuals within the potentially exposed local and global populations would be about 718 person-rem, which would result in about 0.4 health effects within the entire group of potentially exposed individuals. A portion of the PuO<sub>2</sub> released in an accident during either of these phases would be transported beyond 100 km (62 mi). In this event, about two-thirds of the estimated radiological consequences would occur within the global population.

---

<sup>5</sup> An average of about 0.36 rem per year for an individual in the United States, including both natural sources and other sources such as medical X-rays; see Section 3.2.5 for further information.

### *Accidents Beyond the Launch Area*

- Phase 2 (Late Launch): A launch accident occurring during this phase would not result in a release of PuO<sub>2</sub> since undamaged aeroshell modules would survive water impact at terminal velocity. There would be no health consequences.
- Phase 3 (Pre-Orbit): The total probability of an accident resulting in a release during this phase is considered to be unlikely, about 1 in 1,300. The maximum (mean value) dose received by an individual within the exposed global population would be about 0.1 rem, or the equivalent of about 30 percent of the normal annual background dose received by each member of the U.S. population during a year. The collective dose received by all individuals within the potentially exposed global population would be about 3 person-rem, which would result in about 0.002 health effects within the exposed population.
- Phase 4 (Orbit): The total probability of an accident resulting in a release during this phase is considered to be unlikely, about 1 in 1,100. The maximum (mean value) dose received by an individual within the potentially exposed global population would be about 0.4 rem, or the equivalent of about 110 percent of the normal annual background dose received by each member of the U.S. population during a year. The collective dose received by all individuals within the potentially exposed global population would be about 34 person-rem, resulting in about 0.02 health effects within the exposed population.
- Phase 5 (Escape): No accidents were identified that would result in a release of PuO<sub>2</sub> from the RTG. There would be no health consequences.

### *Overall Mission*

- The total probability of an accident resulting in a release across the entire mission is considered to be unlikely, about 1 in 300. The maximum dose received by an individual within the potentially exposed population would be about 0.3 rem, or about 80 percent of the normal background dose received by each member of the U.S. population annually. The collective dose received by all individuals within the potentially exposed population (both within 100 km (62 mi) of the launch site and globally) would be about 352 person-rem, resulting in about 0.2 health effects within the exposed population.

For the unlikely accidents in and near the launch area (Phases 0 and 1), as well as pre-orbit (Phase 3) and orbit (Phase 4) accidents, the mean health effects (i.e., additional latent cancer fatalities) are estimated to be small (0.002 to 0.4) within the potentially exposed population.

The predicted maximum radiological dose to an individual within the exposed population (i.e., the maximally exposed individual) ranges from very small to less than a rem for the very unlikely launch area (Phases 0 and 1) accidents. Assuming no interdiction, such as sheltering and exclusion of people from contaminated land areas, the potentially exposed population is estimated to inhale enough material to result in 0.4 health effects.



There is a range of accidents that have different probabilities of occurrence and consequences. Included are a number of accidents evaluated in the risk assessment for this FEIS that could occur at much lower total probabilities but result in higher consequences. For Phases 0 and 1, most of these accidents were determined to range from very unlikely to extremely unlikely, that is, having total probabilities of release in the range of 1 in 10,000 to 1 in 1 million or less. These postulated accidents could result in higher releases of the RTG inventory (ranging from 0.02 percent to 2 percent), with the potential for mean consequences 10 to several hundred times greater than those summarized above. With extremely unlikely events, such as an intact ground impact of the entire Atlas V vehicle<sup>6</sup> with a total probability of release of 1 in 1.4 million, the maximally exposed off-site individual could receive a dose of 10 to 50 rem, and, assuming no mitigation actions such as sheltering and exclusion of people from contaminated land areas, the potentially exposed population could incur approximately 100 health effects.

The specific probability values presented in this FEIS are estimates and will likely differ from those presented in the more detailed FSAR being prepared by DOE for the New Horizons mission. Some probabilities will likely increase while others may decrease. However, NASA expects the overall probability of an accidental release of radioactive material will not vary substantially from the values presented in this FEIS.

#### *Impacts of Radiological Releases on the Environment*

In addition to the potential human health consequences of launch accidents that could result in a release of PuO<sub>2</sub>, environmental impacts could also include contamination of natural vegetation, wetlands, agricultural land, cultural, archaeological and historic sites, urban areas, inland water, and the ocean.

Potential environmental contamination was evaluated in terms of areas exceeding various screening levels and dose-rate related criteria considered in evaluating the need for land cleanup following radioactive contamination. In the risk assessment for this FEIS, land areas contaminated at or above a level of 0.2 microcuries per square meter ( $\mu\text{Ci}/\text{m}^2$ ) have been identified. This is a screening level used in prior NASA environmental documentation (e.g., NASA 1989, NASA 1997, NASA 2003) to identify areas potentially needing further action, such as monitoring or cleanup. The results for the mean land area contaminated at or above a level of  $0.2\mu\text{Ci}/\text{m}^2$  are summarized below.

- Phases 0 and 1 (Pre-Launch and Early Launch): 1.8 square kilometers ( $\text{km}^2$ ) (0.7 square miles ( $\text{mi}^2$ )).
- Phase 2 (Late Launch): none.
- Phase 3 (Pre-Orbit):  $0.009 \text{ km}^2$  ( $0.003 \text{ mi}^2$ ).
- Phase 4 (Orbit):  $0.02 \text{ km}^2$  ( $0.008 \text{ mi}^2$ ).
- Phase 5 (Escape): none.

---

<sup>6</sup> Referred to as Full Stack Intact Impact (FSII) in Chapter 4.

The risk assessment indicates that the unlikely launch area accident (involving the intentional destruction of all launch vehicle stages freeing the RTG to fall to the ground) would result in about 1.6 km<sup>2</sup> (0.6 mi<sup>2</sup>) being contaminated above 0.2 μCi/m<sup>2</sup>. The risk assessment also indicates that in the extremely unlikely event that the on-board safety systems fail (involving ground impact of the entire launch vehicle), nearly 300 km<sup>2</sup> (about 115 mi<sup>2</sup>) might be contaminated above 0.2 μCi/m<sup>2</sup>.

The area of land contaminated above the U.S. Environmental Protection Agency's (EPA) lifetime-risk criterion, associated with an average annual dose rate criterion of 15 millirem per year (mrem/yr), is estimated to range from 3 to 6 times higher than the land area contaminated above the 0.2 μCi/m<sup>2</sup> level in the first year following a release. This is due in part to the resuspension contribution to dose. Following the first year, the areas contaminated above the 15 mrem/yr criterion would be expected to decrease to values comparable to that associated with the 0.2 μCi/m<sup>2</sup> level.

Costs associated with potential characterization and cleanup, should decontamination be required, could vary widely (\$93 million to \$520 million per km<sup>2</sup> or about \$241 million to \$1.3 billion per mi<sup>2</sup>) depending upon the characteristics and size of the contaminated area. The Price-Anderson Act, as amended (42 U.S.C. 2210), governs liability and compensation in the event of a nuclear incident arising out of the activities of the DOE. In the case of the New Horizons mission, DOE retains title to the RTG. The RTG would, therefore, be subject to Price-Anderson Act provisions. In the unlikely event that an accident were to occur resulting in release of PuO<sub>2</sub>, affected property owners would be eligible for reimbursement for loss of property due to contamination.

In addition to the potential direct costs of radiological surveys, monitoring, and potential cleanup following an accident, there are potential secondary societal costs associated with the decontamination and mitigation activities due to launch area accidents. Those costs may include:

- temporary or longer term relocation of residents;
- temporary or longer term loss of employment;
- destruction or quarantine of agricultural products, including citrus crops;
- land use restrictions (which could affect real estate values, tourism and recreational activities);
- restriction or bans on commercial fishing; and
- public health effects and medical care.

#### 2.4.3.3 Mission Risks

To place the estimates of potential health effects due to launch accidents for the proposed New Horizons mission into a perspective that can be compared with other human undertakings and events, it is useful to use the concept of risk. Risk is commonly viewed as the possibility of harm or damage. For the New Horizons mission, public risk is characterized in terms of the expectation of health effects in a statistical

sense. The risk for each mission phase and for the overall mission is estimated by multiplying the total probability of a release by the health effects resulting from that release. Risk calculated in this manner can also be interpreted as the probability of one health effect occurring in the exposed population. The risks are estimated for the exposed population and for individuals within the exposed population.

### *Population Risks*

Population risk can be interpreted as the probability of one health effect occurring in the exposed population. For the New Horizons mission, overall population health effects risk (i.e., the probability of a health effect occurring as a result of the launch) is estimated to be 1 in 1,700. For accidents that may occur in the launch area (during the Pre-Launch and Early Launch Phases), only a portion of the total population within 100 km (62 mi) of the launch site would be exposed. The total probability of a health effect within the regional population is about 1 in 5,300, or about one third of the total risk for the overall mission. For the global population (excluding those exposed in the launch area region) the risk would be due to the potential for accidental release occurring from Pre-Launch through Pluto trajectory insertion and was estimated to be about 1 in 2,600, or about two thirds of the total risk.

### *Individual Risks*

Individual risk can be interpreted as the probability of an individual in the exposed population incurring a fatal cancer. The average individual risk is defined as the population risk divided by the number of persons exposed. For an accident near the launch site, not everyone within the regional area would be expected to receive a dose as a result of the accident. Due to meteorological conditions prevailing at the time of launch, only a portion of the total regional population is estimated to receive some radiological exposure. The average individual risk, therefore, is estimated to be about 1 in 2 billion in the potentially exposed population near the launch site and less than 1 in 2 trillion in the potentially exposed global population. This means, for example, that a typical individual within 100 km (62 mi) of the launch site has less than a 1 in 2 billion chance of incurring a health effect associated with implementation of the New Horizons mission.

While some individuals within the population, such as those very close to the launch area, would face higher risks, those risks are predicted to be very small. The highest risk to the maximally exposed individual within the regional population is estimated to be less than a 1 in 1 million for the New Horizons mission.

These risk estimates are small compared to other risks. For example, Table 2-5 presents information on annual individual fatality risks to residents of the United States due to various types of hazards. This data indicates that in 2000 the average individual risk of accidental death in the U.S. was about 1 in 3,000 per year, while the average individual risk of death due to any disease, including cancer, was about 1 in 130.

**TABLE 2-5. CALCULATED INDIVIDUAL RISK AND PROBABILITY OF FATALITY BY VARIOUS CAUSES IN THE UNITED STATES IN 2000**

<b>Accident Type</b>	<b>Number of Fatalities</b>	<b>Approximate Individual Risk Per Year</b>	<b>Probability</b>
Railway	25	$8.88 \times 10^{-8}$	1 in 11 million
Floods	38	$1.35 \times 10^{-7}$	1 in 7 million
Tornadoes	41	$1.46 \times 10^{-7}$	1 in 6.8 million
Lightning	51	$1.81 \times 10^{-7}$	1 in 6 million
Extreme Heat	158	$5.61 \times 10^{-7}$	1 in 2 million
Legal Intervention	345	$1.23 \times 10^{-6}$	1 in 800,000
All Weather	476	$1.69 \times 10^{-6}$	1 in 600,000
Manufacturing	668	$2.37 \times 10^{-6}$	1 in 400,000
Accidental Discharge of Firearms	808	$2.87 \times 10^{-6}$	1 in 300,000
Water, Air and Space Transport Accidents (includes unspecified transport accidents)	1,786	$6.35 \times 10^{-6}$	1 in 200,000
Accidental Exposure to Smoke, Fires and Flames	3,265	$1.16 \times 10^{-5}$	1 in 90,000
Accidental Drowning and Submersion	3,343	$1.19 \times 10^{-5}$	1 in 80,000
All Injuries at Work	5,291	$1.88 \times 10^{-5}$	1 in 50,000
Accidental Poisoning and Exposure to Noxious Substances	9,893	$3.52 \times 10^{-5}$	1 in 30,000
Falls	12,604	$4.48 \times 10^{-5}$	1 in 20,000
Drug-induced deaths	15,852	$5.63 \times 10^{-5}$	1 in 18,000
Assault (Homicide)	16,137	$5.73 \times 10^{-5}$	1 in 17,000
Alcohol-induced deaths	18,539	$6.59 \times 10^{-5}$	1 in 15,000
Suicide	28,332	$1.01 \times 10^{-4}$	1 in 10,000
Motor Vehicle	41,804	$1.49 \times 10^{-4}$	1 in 7,000
All Accidents	93,592	$3.33 \times 10^{-4}$	1 in 3,000
All Diseases	2,192,094	$7.79 \times 10^{-3}$	1 in 130
<b>All Causes</b>	<b>2,404,598</b>	<b><math>8.54 \times 10^{-3}</math></b>	<b>1 in 100</b>

Sources: USBC 2000, BLS 2000, NOAA 2001, HHS 2001

Note: The population of the United States for the year 2000 was 281,421,906.

#### 2.4.4 Radiological Contingency Response Planning

Prior to launch of the New Horizons mission, a comprehensive set of plans would be developed by NASA to ensure that any launch accident could be met with a well-developed and tested response. NASA's plans would be developed in accordance with the National Response Plan (NRP) and the NRP Radiological Incident Annex with the combined efforts of the U.S. Department of Homeland Security (DHS), the DHS's Federal Emergency Management Agency, DOE, the U.S. Department of Defense

(DOD), the U.S. Department of State (DOS), the EPA, the State of Florida, Brevard County, and local organizations involved in an emergency response.

The plans would be tested prior to launch in exercises designed to verify the response interfaces, command channels, and field responses to ensure that the various organizations would be prepared to respond in the unlikely event of a launch accident. NASA would be the Principal Technical Agency, working with the DHS to coordinate the entire federal response for launch accidents occurring within United States jurisdiction. Should a release of radioactive material occur in the launch area, the State of Florida, Brevard County, and local governments would determine an appropriate course of action for any off-site plans (such as sheltering in place, evacuation, exclusion of people from contaminated land areas, or no action required) and have full access to the DHS-coordinated federal response. For accidents outside United States jurisdiction, NASA would assist the DOS in coordinating the United States' response via diplomatic channels and using federal resources as requested.

To manage the radiological contingency response, NASA would establish a Radiological Control Center (RADCC) at KSC prior to and during the mission launch. The RADCC would be where NASA's and DHS's coordination efforts would be managed. The RADCC would also be used to coordinate the initial federal response to a radiological contingency once the vehicle has left the launch site area until the New Horizons spacecraft has left Earth orbit. Participation in the RADCC would include NASA, DHS, DOE, DOD, DOS, the EPA, USAF, the National Oceanic and Atmospheric Administration, the State of Florida, and Brevard County. An additional off-site location would be established from which radiological monitoring and assessment could be conducted.

If impact occurs in the ocean, NASA would work with the DHS, the DHS's U.S. Coast Guard, the U.S. Navy, and DOE to initiate security measures and search and retrieval operations. Efforts to recover the RTG or its components would be based on technological feasibility and any potential health hazard presented to recovery personnel and the environment.

This page intentionally left blank.

### **3 DESCRIPTION OF THE AFFECTED ENVIRONMENT**

This chapter of the Final Environmental Impact Statement (FEIS) for the New Horizons mission briefly describes the local and global areas that could potentially be affected by implementing the Proposed Action. Local impacts could affect the regional area surrounding the launch site at Cape Canaveral Air Force Station (CCAFS), Florida. Global impacts could affect the global atmosphere and landmass.

Both the local and global environments have been addressed in previous National Environmental Policy Act (NEPA) documentation and are summarized in this chapter. Principal sources for the information include the U.S. Air Force's (USAF) *Final Environmental Impact Statement for the Evolved Expendable Launch Vehicle Program* (USAF 1998), *Final Supplemental Environmental Impact Statement for the Evolved Expendable Launch Vehicle Program* (USAF 2000), and the National Aeronautics and Space Administration's (NASA) *Final Environmental Assessment for Launch of NASA Routine Payloads on Expendable Launch Vehicles from Cape Canaveral Air Force Station, Florida and Vandenberg Air Force Base California* (NASA 2002). Other documentation summarized includes, but is not limited to, the CCAFS *Integrated Natural Resource Management Plan* (USAF 2001) and the Kennedy Space Center's (KSC) *Environmental Resources Document* (NASA 2003).

The primary launch opportunity for the proposed New Horizons mission to Pluto would occur in January – February 2006, and a backup launch opportunity would occur in February 2007.

Section 3.1 describes the affected environment at and surrounding CCAFS, and Section 3.2 discusses the global environment.

#### **3.1 CAPE CANAVERAL AIR FORCE STATION REGIONAL AREA**

CCAFS is located on the east coast of Florida in Brevard County on the Canaveral Peninsula (Figure 3-1). The Canaveral Peninsula is a barrier island located approximately 96 kilometers (km) (60 miles (mi)) east of Orlando. The regional area, within a 100 km (62 mi) radius of CCAFS, includes all or the major portions of six counties, including Brevard, Indian River, Orange, Osceola, Seminole, and Volusia (the six-county region) and minor portions of Flagler, Lake, Polk, Okeechobee, and St. Lucie counties. The northern boundary of CCAFS abuts the KSC boundary on the barrier island (Figure 3-2). The southern boundary abuts Port Canaveral. CCAFS is separated from KSC to the west by the Banana River. The Atlantic Ocean borders CCAFS along its eastern boundary. The Merritt Island National Wildlife Refuge (MINWR) lies within the boundaries of KSC.

##### **3.1.1 Land Use**

The six-county region covers approximately 1.7 million hectares (ha) (4.1 million acres (ac)), of which approximately 1.3 million ha (3.3 million ac) is land and 0.3 million ha (0.8 million ac) is water (USBC 2000). Land use includes urbanized areas or areas devoted to transportation and other rights-of-way (approximately 17 percent of the total

area) and agricultural land (22 percent). The three principal agricultural uses are crops (3 percent), citrus (4 percent), and pasturage (14 percent) (USAF 2001). The region also has historical and archaeological sites.

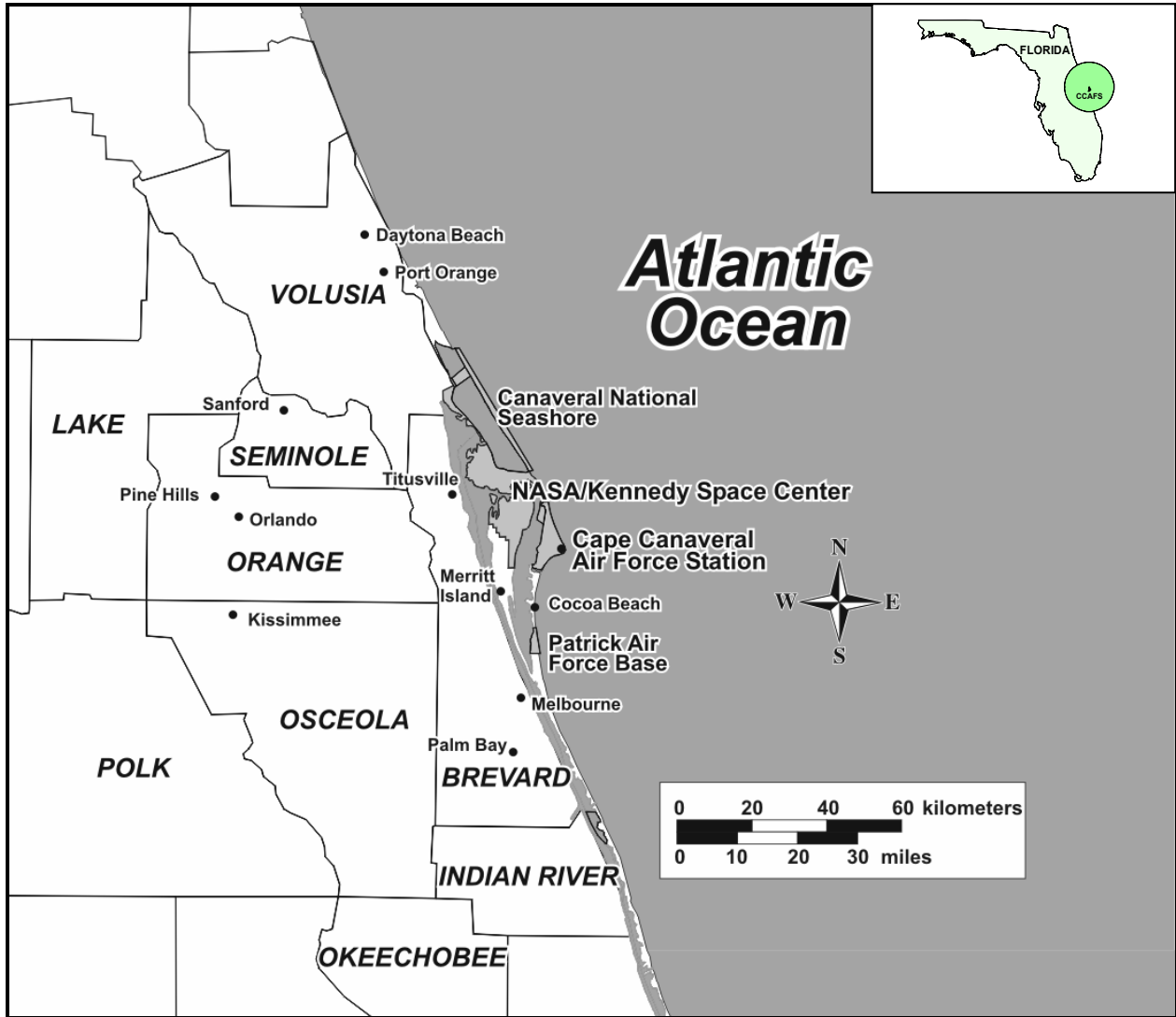

**FIGURE 3-1. THE REGIONAL AREA NEAR CCAFS**

CCAFS occupies about 6,400 ha (15,800 ac) of the barrier island that also contains the City of Cape Canaveral. Major land uses at CCAFS include launch operations and launch support, restricted development, port operations, industrial area, and airfield operations. Approximately 1,600 ha (3,900 ac) or 25 percent of the station is developed, with over 40 space launch complexes (SLC) and support facilities, many of which have been deactivated. The remaining 75 percent (about 4,800 ha (11,900 ac)) is undeveloped land (USAF 2001).



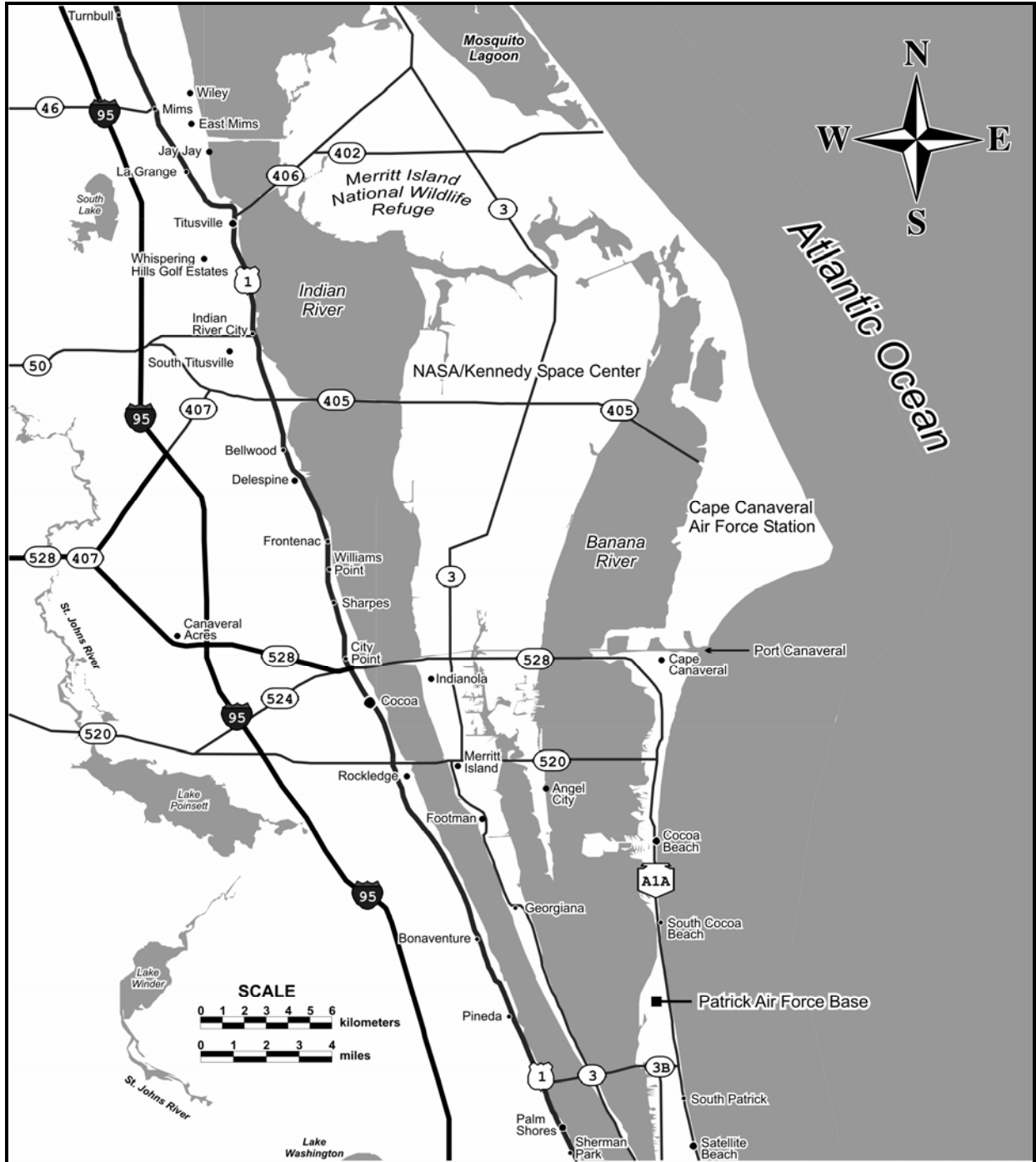

**FIGURE 3-2. CCAFS AND THE SURROUNDING AREA**

KSC, immediately to the west of CCAFS, occupies about 56,700 ha (140,000 ac) of Merritt Island. Only about 3 percent (1,540 ha (3,800 ac)) of KSC is developed or designated for NASA use. About 40 percent of the KSC area (21,900 ha (54,200 ac)) is open water. NASA has delegated management of the undeveloped areas within KSC to the U.S. Fish and Wildlife Service (FWS) and to the National Park Service (NPS) (NASA 2003).

Land use surrounding CCAFS involves urban areas with land devoted to transportation and other rights-of-way, an active seaport, recreation and wildlife management areas, and agricultural uses, including crops, citrus, and pasturage.

The Atlas V launch vehicle planned for the proposed New Horizons mission would be launched from Space Launch Complex 41 (SLC-41), which is located in the southernmost section of KSC. NASA has permitted CCAFS to use SLC-41 and the surrounding land.

### 3.1.2 Atmospheric Environment

#### 3.1.2.1 Climate

The climate of the region is subtropical with two definite seasons: long, warm, humid summers and short, mild, dry winters. Temperatures in both summer and winter are moderated by the waters of the Indian River Lagoon system and the Atlantic Ocean. Maximum temperatures in summer show little day to day variation. Minimum temperatures in winter may vary considerably from day to day, largely due to cold fronts that move across the United States from the northwest to the east and southeast. Rainfall is heaviest in summer, with about 65 percent of the annual total of 142 centimeters (cm) (56 inches (in)) falling from June through October in an average year. The other 35 percent is evenly distributed throughout the average year. Thunderstorms bringing high winds and heavy rain typically occur from May through September. Surface mixing typically occurs during the winter and summer. Climatological data from KSC indicates that winds during the Proposed Action's launch opportunity would occur predominantly from north-northwest (Table 3-1). Sea breezes (winds from the ocean towards land) and land breezes (winds from land towards the ocean) commonly occur daily during summer and fall. Sea breezes occur at the surface during the day, and land breezes occur at night (USAF 1998, USAF 2001).

CCAFS is vulnerable to hurricanes and their associated storm tides during the summer and fall. Historic data show that the storm tide height for a Category 5 (strongest) hurricane would reach to 4.6 meters (m) (15 feet (ft)), inundating most of CCAFS. The high hurricane winds necessitate adherence to special construction codes, established to reduce wind load-damage to structures (USAF 2001).

#### 3.1.2.2 Air Quality

Air quality is regulated through the National Ambient Air Quality Standards (NAAQS) promulgated under the Clean Air Act, as amended (42 U.S.C. 7401 et seq.) (CAA). Under NAAQS, Federal primary and secondary air quality standards are established for six criteria pollutants: carbon monoxide (CO), lead (Pb), nitrogen dioxide (NO<sub>2</sub>), ozone (O<sub>3</sub>), particulate matter (PM<sub>10</sub> and PM<sub>2.5</sub>, particulate matter less than 10 and 2.5 microns in diameter, respectively), and sulfur dioxide (SO<sub>2</sub>). The Federal primary standards set limits to protect public health, including the health of sensitive populations such as asthmatics, children, and the elderly. The Federal secondary standards set limits to protect public welfare, including protection against decreased visibility, damage to

animals, crops, vegetation, and buildings from any known or anticipated adverse effects of a pollutant (EPA 2003a).

**TABLE 3-1. CLIMATOLOGY DATA FOR BREVARD COUNTY, FLORIDA**

Month	Surface Winds		Precipitation <sup>(a)</sup>		Fog	Thunderstorms
	Prevailing Direction	Mean Speed (km per hour (mph))	≥0.25 cm (≥0.1 in)	≥1.27 cm (≥0.5 in)	Visibility <3.2 km (<2 mi)	
Mean Number of Days Occurrence						
January	NNW	13 (8)	4	2	9	1
February	N	13 (8)	5	2	7	2
March	SSE	13 (8)	6	3	7	3
April	E	14 (9)	5	3	4	3
May	E	13 (8)	6	2	3	8
June	E	11(7)	10	4	2	13
July	S	10 (6)	13	5	2	16
August	E	10 (6)	9	5	2	14
September	E	10 (6)	12	6	2	10
October	E	13 (8)	6	5	3	4
November	N	11 (7)	3	1	6	1
December	NW	13 (8)	4	1	7	1
Annual	E	11 (7)	83	39	54	76
Years of Record	10	10			26	26

Sources: USAF 1998, USAF 2001

(a) Snowfall has not occurred in over three decades.

Florida has also established air quality standards for criteria pollutants (FAC 62-204.240). The State standards closely follow the Federal standards, with the following differences: Florida has not established a standard for PM<sub>2.5</sub>, and has set a standard for SO<sub>2</sub> that is more stringent than the Federal standard for comparable measurement averaging times.

Air quality at CCAFS is considered good (FDEP 2002). Table 3-2 compares ambient concentrations with current Federal and State standards. Ambient concentrations of criteria pollutants for Brevard and Orange Counties for 2001 did not exceed the Federal or State standards. Brevard County, including CCAFS, is considered by the Florida Department of Environmental Protection (FDEP) to be in attainment or unclassifiable with respect to criteria pollutants (FDEP 2002). Therefore, the CAA General Conformity Rule would not apply.

On July 18, 1997, the U.S. Environmental Protection Agency (EPA) adopted the 8-hour O<sub>3</sub> standard, which is intended to eventually replace the one-hour standard. On April 15, 2004, the EPA issued the first phase of the final rule in the Federal Register (FR),

designating nonattainment areas of the country that exceed the new standard (69 FR 23857). The EPA designated the entire State of Florida as unclassifiable/attainment for the new 8-hour O<sub>3</sub> standard.

Also on July 18, 1997, the EPA promulgated a new standard for fine particles (PM<sub>2.5</sub>). States were required to submit their recommendations for designating individual counties as attainment or nonattainment by February 2004. On January 5, 2005, the EPA agreed with Florida's recommendations and classified the entire State of Florida as unclassifiable/attainment for the new fine particle standard (70 FR 943).

**TABLE 3-2. SUMMARY AIR QUALITY DATA NEAR CCAFS FOR 2002**

Criteria Pollutant	Federal Standard <sup>(a)</sup> µg/m <sup>3</sup> (ppm)		Florida State Standard µg/m <sup>3</sup> (ppm)	2002 Ambient Concentrations µg/m <sup>3</sup> (ppm)
Carbon Monoxide (CO)				
1-hour Average	40,000 (35)	Primary	40,000 (35)	(5)
8-hour Average	10,000 (9)	Primary	10,000 (9)	(3)
Lead (Pb)				
Quarterly Average	1.5	Both Primary & Secondary	1.5	no data
Nitrogen Dioxide (NO <sub>2</sub> )				
Annual Arithmetic Mean	100 (0.053)	Both Primary & Secondary	100 (0.053)	(0.011)
Ozone (O <sub>3</sub> )				
1-hour Average	235 (0.12)	Both Primary & Secondary	235 (0.12)	(0.090)
8-hour Average	157 (0.08)	Secondary	no standard	(0.076)
Particulate Matter (PM <sub>10</sub> )				
Annual Arithmetic Mean	50	Both Primary & Secondary	50	18
24-hour Average	150	Secondary	150	67
Particulate Matter (PM <sub>2.5</sub> )				
Annual Arithmetic Mean	15	Both Primary & Secondary	no standard	7.8
24-hour Average	65	Secondary	no standard	24
Sulfur Dioxide (SO <sub>2</sub> )				
Annual Arithmetic Mean	80 (0.03)	Primary	60 (0.02)	(0.001)
24-hour Average	365 (0.14)	Primary	260 (0.10)	(0.005)
3-hour Average	1,300 (0.5)	Secondary	1,300 (0.5)	(0.013)

Sources: EPA 2003a, FAC 62-204.240, FDEP 2002

(a) Federal primary standards are levels of air quality necessary, with an adequate margin of safety, to protect the public health. Federal secondary standards are levels of air quality necessary to protect the public welfare from any known or anticipated adverse effects of a pollutant.

µg/m<sup>3</sup> = micrograms per cubic meter

ppm = parts per million

### 3.1.3 Ambient Noise

Ambient noise levels at CCAFS have not been monitored. The USAF has initiated a project to study the effects of rocket launch noise (USAF 2001). The 24-hour average ambient noise levels at KSC, where similar industrial activities occur, is lower than the upper level of 65 A-weighted decibels (dBA) recommended by the EPA (NASA 2003). Noise levels at resorts and on the beaches near Cape Canaveral probably range from 45 to 55 dBA (USAF 1998).

### 3.1.4 Geology and Soils

CCAFS, composed of relict beach ridges, is 7.2 km (4.5 mi) at its widest point with elevations ranging from sea level to 6 m (20 ft) above mean sea level (USAF 2001).

The four stratigraphic units from surface downwards are: the surficial sands, the Caloosahatchee Marl, Hawthorn Formation, and the limestone formations of the Floridan Aquifer. The Hawthorn Formation separates the Floridan Aquifer from the shallower aquifers (groundwater basins) in the area. The Upper Floridan Aquifer is under artesian pressure (the natural pressure that helps boost water upwards in wells) in the vicinity of CCAFS. CCAFS is not in an active sinkhole area. It lies in a Seismic Hazard Zone 0 (very low risk of seismic events) (USAF 1998).

Soils in the CCAFS area include five major associations. The three most prominent soil types are contained in the Canaveral-Palm Beach-Welaka Association. These soils are highly permeable and allow water to quickly percolate into the ground and have a high buffering capacity (Schmalzer et al. 1998). No prime or unique farmland is present at CCAFS (USAF 1998).

### 3.1.5 Hydrology and Water Quality

#### 3.1.5.1 Surface Waters

The major surface water resources in the region include the upper St. Johns River basin, the Indian River, the Banana River, the Mosquito Lagoon (Figure 3-2), and a portion of the Kissimmee River on the western border of Osceola County. Except for the portions that are part of the Intercoastal Waterway between Jacksonville and Miami, these water bodies are shallow, estuarine lagoons. The Indian and Banana Rivers are connected by the Barge Canal at Port Canaveral. Surface drainage at CCAFS is generally westward toward the Banana River (USAF 1998).

The 100-year floodplain on CCAFS extends 2 m (7 ft) above mean sea level on the Atlantic Ocean side to the east and 1.2 m (4 ft) above mean sea level on the Banana River side to the west. SLC-41 does not lie within the 100-year floodplain and is not located within a wetland (USAF 1998).

The St. Johns River, from Lake Washington south, and its tributaries are classified by the State of Florida as Class I surface waters (potable water supply) and serve as the source of potable water for Melbourne and for much of the surrounding population. Near CCAFS, the Mosquito Lagoon and portions of the Indian River have been

designated as Class II waters (shellfish propagation and harvesting) (Figure 3-3). The remaining surface waters in the vicinity (the Banana Creek, the Banana River, and portions of the Indian River south of Titusville) have been designated as Class III waters (recreation, fish, and wildlife management).

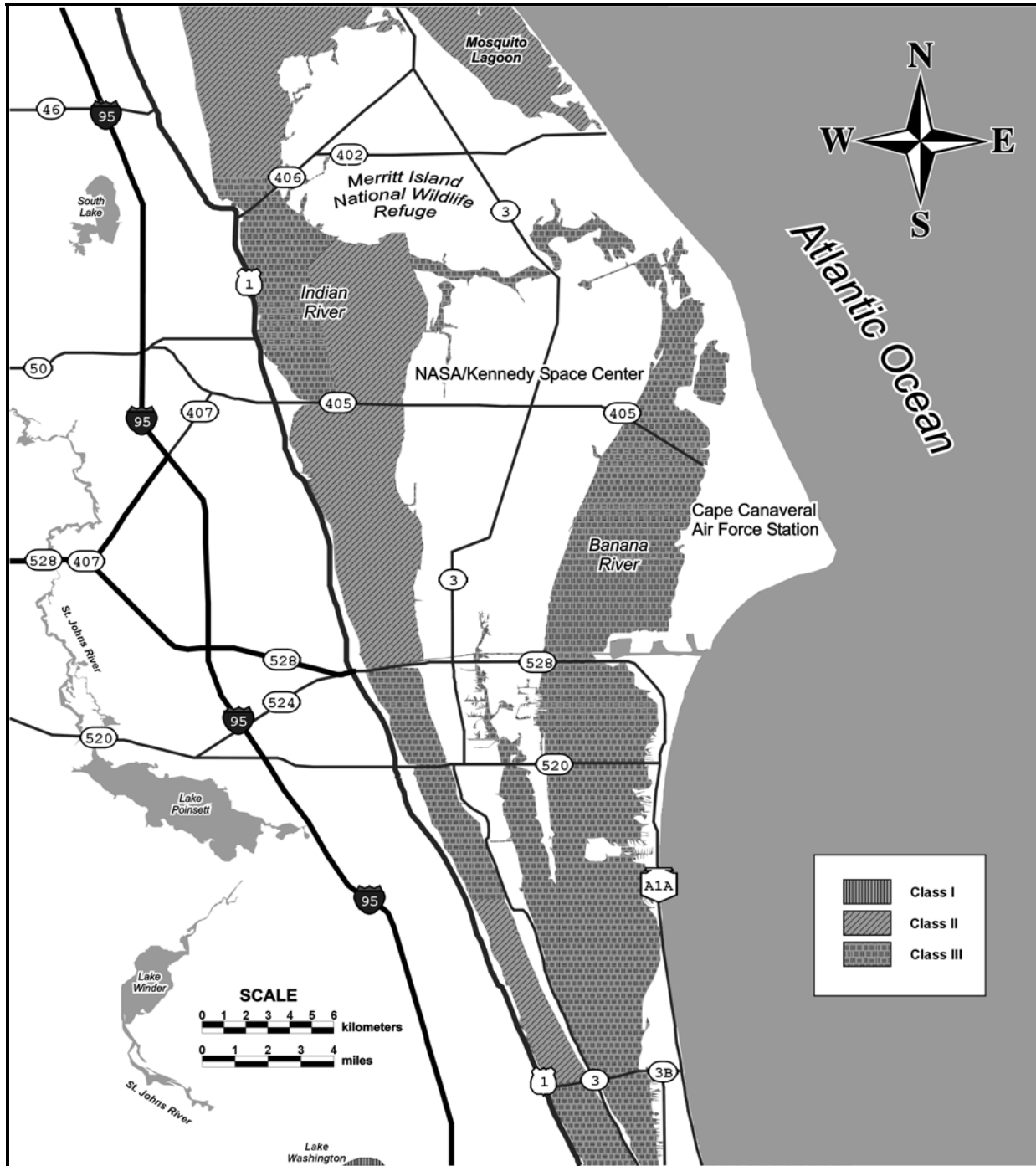

**FIGURE 3-3. SURFACE WATER CLASSIFICATIONS NEAR CCAFS**

Areas of the Banana River south of CCAFS, and the entire Mosquito Lagoon north of CCAFS have been designated as Aquatic Preserves under Florida's Aquatic Preserve Act of 1975 (FAC 62-302.700). Aquatic Preserves have exceptional biological, aesthetic, and scientific values and have substantial restrictions placed on activities like oil and gas drilling and effluent discharges (NASA 2003).

Surface waters within the MINWR, the Canaveral National Seashore, and the Banana River Aquatic Preserve located near CCAFS have been designated as Outstanding Florida Waters (Figure 3-4), and as such are afforded the highest protection by the State of Florida (FAC 62-302.700). The State established this special designation for surface waters that demonstrate recreational or ecological significance. Other Outstanding Florida Waters in the vicinity of CCAFS include the Mosquito Lagoon Aquatic Preserve, the Archie Carr National Wildlife Refuge, the Pelican Island National Wildlife Refuge, the Sebastian Inlet State Recreation Area, the Indian River Aquatic Preserve – Malabar to Vero Beach, and the Indian River North Beach Program Area. In addition, the EPA's National Estuary Program has selected the Indian River Lagoon System, which includes the Mosquito Lagoon, as an Estuary of National Significance. The goal of this program is to balance conflicting uses of the Nation's estuaries while restoring or maintaining their natural character. No designated wild or scenic rivers are located on or near CCAFS (USAF 1998, NASA 2003).

#### 3.1.5.2 Surface Water Quality

Brevard County, the State of Florida, and the U.S. Fish and Wildlife Service (FWS) maintain long-term water quality monitoring stations located in the Mosquito Lagoon, the Banana River, the Banana Creek, the Indian River, and other locations on or near KSC. Surface water quality has been characterized as generally good, with best areas of water quality adjacent to undeveloped areas of the lagoon, i.e., the North Banana River, the Mosquito Lagoon, and the northern-most portion of the Indian River. The waters tend to be alkaline and have good buffering capacity. Water samples have been analyzed for various parameters from inland bodies of water near CCAFS and KSC. Certain metals (e.g., aluminum, calcium, chlorides, iron, magnesium, potassium, sodium), a pesticide (dieldrin), and some poly aromatic hydrocarbons (e.g., naphthalene, fluorene) were measured above detection limits. However, the detection limits for these parameters were below the Class I (potable water) and Class II (shellfish propagation and harvesting) water quality criteria except for dieldrin (NASA 2003).

#### 3.1.5.3 Groundwater Sources

Groundwater underlying CCAFS occurs in three aquifer systems: the surficial aquifer, a secondary semi-confined aquifer, and the Floridan Aquifer. The surficial aquifer is unconfined and extends from just below the ground surface to a depth of about 21 m (70 ft). Recharge of the surficial aquifer is largely by percolation of rainfall and runoff. Near CCAFS, wells that tap this aquifer are used primarily for non-potable uses; however, Mims and Titusville, located about 16 km (10 mi) northwest of CCAFS, and Palm Bay, located about 64 km (40 mi) south of CCAFS, use the surficial aquifer for public water supply. The secondary, semi-confined aquifers are found below confining

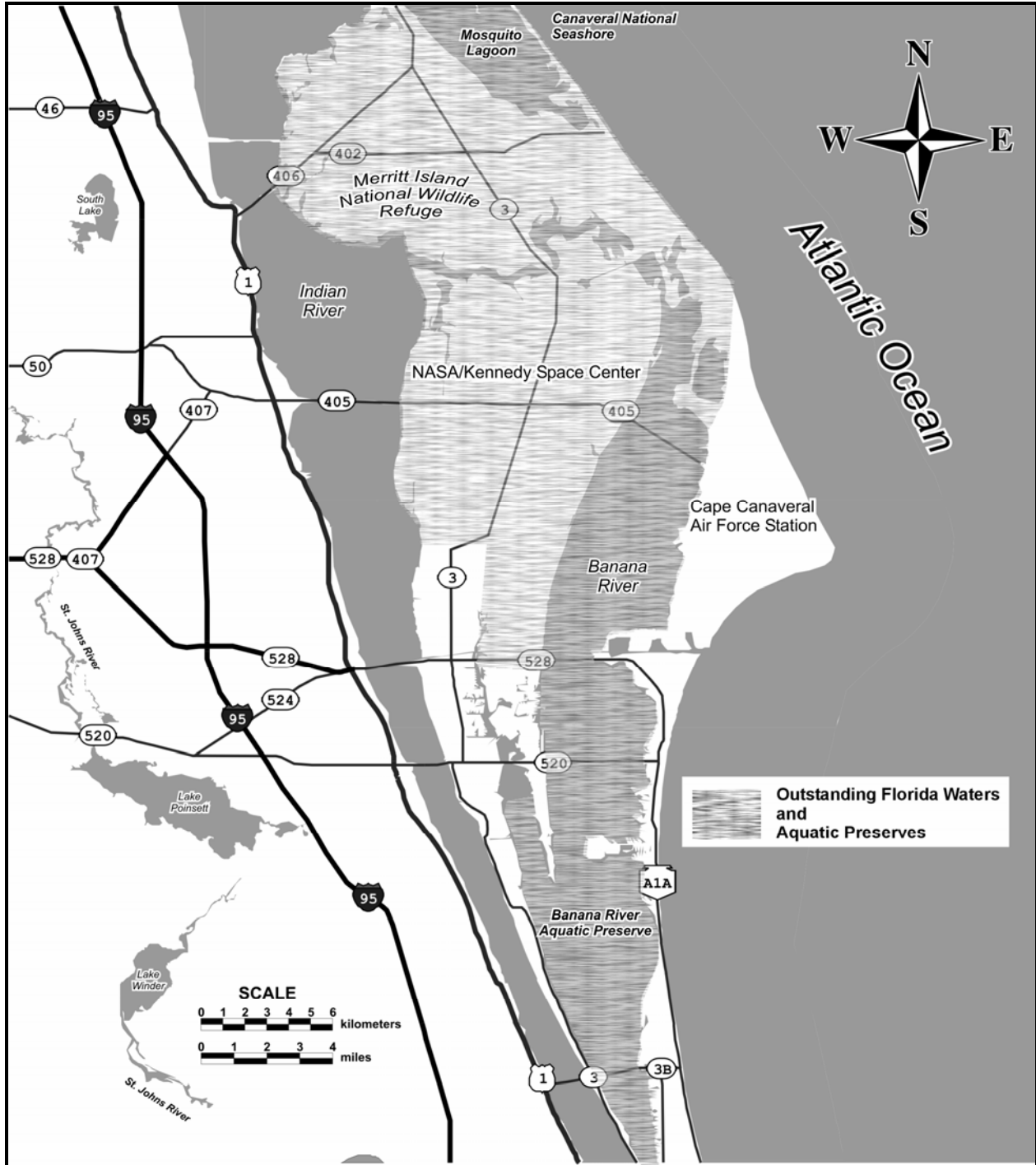

**FIGURE 3-4. OUTSTANDING FLORIDA WATERS AND AQUATIC PRESERVES NEAR CCAFS**

layers, but above and within the Hawthorn Formation. Recharge is minor and depends on leakage through surrounding lower permeability soils. A confining layer of clays, sands, and limestone, ranging from 24 to 37 m (80 to 120 ft) thick, restricts exchange between the surficial aquifer and the deeper Floridan Aquifer. The Floridan Aquifer is



the primary source of potable water in central Florida. CCAFS receives its potable water from the City of Cocoa, which draws its water from a non-brackish area of the Floridan Aquifer (USAF 1998, NASA 2003).

#### 3.1.5.4 Groundwater Quality

In the immediate vicinity of CCAFS, groundwater from the Floridan Aquifer is highly mineralized (primarily by chlorides) because of entrapment of seawater in the aquifer, lateral intrusion caused by inland pumping, and lack of flushing due to the long distance from freshwater recharge areas.

The secondary semi-confined aquifer lies between the surficial aquifer and the Floridan Aquifer and is contained within the relatively thin Hawthorn formation. Groundwater recharge is by upward leakage from the Floridan system as well as lateral intrusion from the Atlantic Ocean. Water quality varies from moderately brackish to brackish.

Groundwater quality in the surficial aquifer system at CCAFS remains good because of immediate recharge, active flushing, and a lack of development. Groundwater from the surficial aquifer meets Florida's criteria for potable water (Class G-II, total dissolved solids less than 10,000 milligrams per liter (mg/l) (10,000 parts per million (ppm)) and national drinking water criteria for all parameters other than iron and total dissolved solids.

There are several sites in Florida listed as manufacturers or users of perchlorates. However, Florida (and therefore Brevard County and CCAFS) is not listed as having areas that contain high levels of perchlorate contamination of groundwater or soils (EPA 2003b).

#### 3.1.5.5 Offshore Environment

The Atlantic Ocean near CCAFS can be characterized by its bottom topography and circulation. Near the shore, sandy shoals dominate the underwater topography. The sea floor continues to deepen from the coast extending to the Blake Plateau.

Offshore currents usually reflect the general northern flow of the Gulf Stream (NOAA 1980). Studies of water movements in the area indicate surface to bottom shoreward currents, although wind generally determines current flow at the surface. From November to April, the prevailing winds transport surface waters toward shore, with an offshore component in shallow bottom waters that diminishes rapidly with distance offshore. The net effect is that material suspended in the water column tends to be confined to the area near the coast, and heavier material (e.g., sand) is deposited in this area. The occasional northward winds result in a net movement of surface waters offshore, with an onshore movement of higher density bottom waters. Materials suspended in surface waters are transported offshore, and heavier bottom materials move onshore. In general, prevailing winds during January and February (the launch opportunity for the proposed New Horizons mission) would occur from the north-northwest (Table 3-1).

In the region out to the sloping bank, flow is slightly to the north and tends to move eastward when the wind blows to the south. Water over the Blake Plateau mostly flows to the north and is known as the Florida current, a component of the Gulf Stream.

### 3.1.6 Biological Resources

As noted in Section 3.1.5.2, the region has several terrestrial and aquatic conservation and special designation areas (e.g., wildlife management areas and aquatic preserves). These areas serve as wildlife habitat and occupy about 25 percent (about 405,000 ha (1 million ac)) of the total land and water acreage within the region.

#### 3.1.6.1 Terrestrial Resources

Table 3-3 provides an overview of the eight general land use-land cover categories in the six-county region. Brevard, Indian River, Seminole, and Volusia counties are entirely within the St. Johns River Water Management District (SJRWMD); Orange and Osceola counties are partly in the SJRWMD and partly in the South Florida Water Management District (SFWMD). Approximately half of the region is rangeland and forests of various types, wetlands, and open water (SFWMD 1995, SJRWMD 1998).

**TABLE 3-3. MAJOR LAND COVER TYPES IN THE CCAFS REGIONAL AREA**

Major Land Use - Land Cover Classification	Brevard County	Indian River County	Orange County	Osceola County	Seminole County	Volusia County	Six-County Region Total
	acres (percent)	acres (percent)	acres (percent)	acres (percent)	acres (percent)	acres (percent)	acres (percent)
Urban and Built-up	126,620 (15.5)	29,113 (9.3)	158,157 (24.6)	48,055 (5.0)	73,692 (33.3)	119,045 (14.9)	554,682 (14.8)
Agriculture	115,727 (14.2)	137,469 (44.0)	92,127 (14.3)	402,628 (41.7)	22,366 (10.1)	52,498 (6.6)	822,815 (21.9)
Rangeland	61,409 (7.5)	19,080 (6.1)	50,953 (7.9)	62,365 (6.5)	7,473 (3.4)	33,590 (4.2)	234,870 (6.3)
Upland Forests	96,279 (11.8)	28,249 (9.0)	109,020 (16.9)	98,685 (10.2)	26,583 (12.0)	226,072 (28.3)	584,888 (15.6)
Water	176,113 (21.6)	18,302 (5.9)	68,013 (10.6)	84,180 (8.7)	25,748 (11.6)	100,799 (12.6)	473,155 (12.6)
Wetlands	218,196 (26.8)	73,703 (23.6)	136,675 (21.2)	257,333 (26.6)	58,590 (26.5)	252,220 (31.6)	996,717 (26.5)
Barren Land	5,348 (0.7)	2,964 (0.9)	4,620 (0.7)	4,496 (0.5)	1,156 (0.5)	3,149 (0.4)	21,733 (0.6)
Transportation, Communication and Utilities	15,086 (1.9)	3,648 (1.2)	24,094 (3.7)	8,192 (0.8)	5,615 (2.5)	10,989 (1.4)	67,624 (1.8)
<b>Total</b>	<b>814,778 (100.0)</b>	<b>312,528 (100.0)</b>	<b>643,659 (100.0)</b>	<b>965,934 (100.0)</b>	<b>221,223 (100.0)</b>	<b>798,362 (100.0)</b>	<b>3,756,484 (100.0)</b>

Sources: Extracted from SJRWMD 1998 and SFWMD 1995

Note: One acre equals 0.4047 hectares (0.004 square kilometers)

The majority of the land at and near CCAFS, including KSC, the MINWR, the Mosquito Lagoon, and the Cape Canaveral National Seashore, is undeveloped and in a near-natural state. These areas host a variety of plant communities, ranging from mangrove swamps and salt marshes to freshwater wetlands, coastal dunes, and beaches. The FWS National Wetlands Inventory conducted in 1994 identified a total of 905 ha (2,235 ac) of wetlands on CCAFS (USAF 1998).

Approximately 75 percent (4,800 ha (11,900 ac)) of the land at CCAFS is undeveloped. Within these undeveloped areas there are eleven natural communities: Beach Dune, Scrub, Hydric Hammock, Coastal Grassland, Xeric Hammock, Estuarine Tidal Swamp, Coastal Strand, Maritime Hammock, Estuarine Tidal Marsh, Coastal Interdunal Swale and Shell Mound (USAF 2001).

These natural communities support many reptile, amphibian, bird, and mammal species. Such species include alligator, snakes, turtles, toads, waterfowl, wading birds, warblers, owls, squirrel, raccoon, white-tail deer, skunk, and rabbit (USAF 2001). In addition, the CCAFS/KSC area including the MINWR is host to diverse populations of migratory birds that are protected by the Migratory Bird Treaty Act, as amended (16 U.S.C. 703 et seq.). Many migratory birds also use this area as wintering grounds (NASA 2003, USAF 2001).

#### 3.1.6.2 Aquatic Resources

The coastline from Daytona to Melbourne is one of the most productive marine fishery areas along the southern Atlantic coast. Diverse freshwater, estuarine, and marine fish inhabit the waters around CCAFS. Inland waters support sea trout and redfish sport fisheries. The tidal zone supports an abundance of several species of marine invertebrates, as well as small fish that are food for many shore birds. Several species of gulls, terns, sandpipers, and other birds use the beaches of the Cape Canaveral area. In addition, these beaches are important to nesting sea turtles.

Commercial and recreational fishing is a major economic asset to the region. Diverse freshwater, estuarine, and marine fish and shellfish inhabit the waters in the CCAFS region. The Mosquito Lagoon is considered among the best oyster and clam harvesting areas on the east coast.

The conservation of essential fish habitat (EFH) is an important component of building and maintaining sustainable fisheries. The Magnuson-Stevens Fishery Conservation and Management Act, as amended (16 U.S.C. 1801 et seq.) (M-S Act), calls for direct action to stop or reverse the continued loss of fish habitats. Toward this end, Congress mandated the identification of habitats essential to managed species and measures to conserve and enhance this habitat. The M-S Act requires cooperation among the U.S. Department of Commerce, acting through the National Marine Fisheries Service (NMFS), eight regional Fishery Management Councils, fishing participants, and Federal and state agencies to protect, conserve, and enhance EFH. Federal agencies are to consult with the NMFS on ways to minimize adverse impacts on EFH from the agencies' non-fishing activities. The USAF has a programmatic consultation in place with the NMFS on EFH regarding Atlas V launches from CCAFS (USAF 2000).

The South Atlantic Fishery Management Council manages identified EFH in the marine area surrounding CCAFS. The Council currently manages habitat for the following species: South Atlantic Snapper-Grouper complex, South Atlantic shrimps, Coastal Migratory Pelagic species, Highly Migratory species, Red Drum, Spiny Lobster, Golden Crab, Calico Scallop and Sargassum.

### 3.1.6.3 Threatened and Endangered Species

The Federal Threatened or Endangered Species List, prepared by the FWS under the Endangered Species Act, as amended (16 U.S.C. 1531 et seq.), currently recognizes 103 endangered or threatened animal and plant species in the state of Florida. Another 14 species (including 13 plants) in the state of Florida are listed as candidate species and are being reviewed for possible Federal listing. No new animal or plant species are proposed for Federal listing as threatened or endangered at this time (FWS 2003). The State of Florida considers 117 animal species as threatened, endangered, or as species of special concern and 413 plant species as threatened, endangered, or commercially exploited (FDACS 2003, FFWCC 2004). Table 3-4 presents a list of Federal and State endangered and threatened species, and species of special concern, known to occur at or near CCAFS (USAF 2001).

A population of Florida Manatee, a subspecies of the endangered West Indian Manatee, occurs near CCAFS. Areas that have been designated as manatee protection areas (refuges and sanctuaries) by the FWS and State of Florida include the entire inland section of the Indian River; the entire inland section of the Banana River; and all the waterways between the Indian and Banana Rivers (exclusive of those existing human-made structures or settlements that are not necessary to the normal needs and survival of the manatee). Specific areas include the waters of the Banana River from State Road 528 north to the NASA Parkway East causeway, the Barge Canal, to the immediate south of CCAFS, Sykes Creek in Brevard County, the Banana River just west of Cocoa Beach, and the Haulover Canal at the north end of Merritt Island (67 FR 680, 67 FR 68450, 69 FR 40796, FAC 68C-22).

Loggerhead, green, and leatherback sea turtles use the beaches at CCAFS as nesting habitat. Nesting typically occurs between May and October. The launch complexes use exterior lighting for safety and security reasons. Sea turtle adults and hatchlings are sensitive to artificial lighting near their nesting beaches. Extensive research has demonstrated that artificial lighting deters adult female turtles from emerging from the water and nesting. After emerging from the nests, the hatchlings use moonlight and starlight reflected off the ocean as a guide to finding the ocean. If the inland lighting is brighter than the reflected light, the hatchlings may get disoriented and never reach the ocean. SLC-41 is within several hundred meters of sea turtle nesting beaches. CCAFS's lighting management plan minimizes light impacts on sea turtle nesting beaches (USAF 2001).

A large population of the threatened southeastern beach mouse has been found at CCAFS launch sites where open grassland habitat is maintained. Coastal grasslands and strand provide habitat for the highest population densities at CCAFS. Other primary habitat is the coastal dune (USAF 1998).

**TABLE 3-4. THREATENED, ENDANGERED, AND SPECIES OF SPECIAL CONCERN OCCURRING ON OR NEAR CCAFS**

Common Name	Scientific Name	Federal Status	State Status
<b>Plants</b>			
Beach-star	<i>Remirea maritima</i>	---	E
Coastal vervain	<i>Verbena maritima</i>	---	E
Curtiss milkweed	<i>Asclepias curtissii</i>	---	E
East coast lantana	<i>Lantana depressa</i> var. <i>floridana</i>	---	E
Hand fern	<i>Ophioglossum palmatum</i>	---	E
Nakedwood	<i>Myrcianthes fragrans</i>	---	T
Nodding pinweed	<i>Lechea cernua</i>	---	T
Sand dune spurge	<i>Chamaesyce cumulicola</i>	---	E
Satinleaf	<i>Chrysophyllum oliviforme</i>	---	T
Scaevola	<i>Scaevola plumieri</i>	---	T
Sea lavender	<i>Tournefortia gnaphalodes</i>	---	E
Shell mound prickly-pear	<i>Opuntia stricta</i>	---	T
<b>Reptiles and Amphibians</b>			
American Alligator	<i>Alligator mississippiensis</i>	T(S/A)	SSC
Atlantic Green Sea Turtle	<i>Chelonia mydas mydas</i>	E	E
Atlantic Hawksbill Turtle	<i>Eretmochelys imbricata</i>	E	E
Atlantic Loggerhead Sea Turtle	<i>Caretta caretta</i>	T	T
Atlantic Ridley Sea Turtle	<i>Lepidochelys kempii</i>	E	E
Eastern Indigo Snake	<i>Drymarchon corais couperi</i>	T	T
Florida Pine Snake	<i>Pituophis melanoleucus mugitus</i>	---	SSC
Gopher Tortoise	<i>Gopherus polyphemus</i>	---	SSC
Leatherback Turtle	<i>Dermochelys coriacea</i>	E	E
<b>Birds</b>			
American Oystercatcher	<i>Haematopus palliatus</i>	---	SSC
Arctic Peregrine Falcon	<i>Falco peregrinus tundrius</i>	---	E
Bald Eagle	<i>Haliaeetus leucocephalus</i>	T	T
Black Skimmer	<i>Rynchops niger</i>	---	SSC
Brown Pelican	<i>Pelecanus occidentalis</i>	---	SSC
Florida Scrub-Jay	<i>Aphelocoma coerulescens</i>	T	T
Least Tern	<i>Sterna antillarum</i>	---	T
Little Blue Heron	<i>Egretta caerulea</i>	---	SSC
Piping Plover	<i>Charadrius melodus</i>	T	T
Reddish Egret	<i>Egretta rufescens</i>	---	SSC
Roseate Spoonbill	<i>Ajaia ajaja</i>	---	SSC
Snowy Egret	<i>Egretta thula</i>	---	SSC
Southeastern American Kestrel	<i>Falco sparverius paulus</i>	---	T
Tricolored Heron	<i>Egretta tricolor</i>	---	SSC
White Ibis	<i>Eudocimus albus</i>	---	SSC
Wood Stork	<i>Mycteria americana</i>	E	E
<b>Mammals</b>			
Finback Whale	<i>Balaenoptera physalus</i>	E	E
Florida Manatee	<i>Trichechus manatus</i>	E	E
Florida Mouse	<i>Podomys floridanus</i>	---	SSC
Gray Bat	<i>Myotis grisescens</i>	E	E
Humpback Whale	<i>Megaptera novaeangliae</i>	E	E
North Atlantic Right Whale	<i>Eubalaena glacialis</i>	E	E
Sei Whale	<i>Balaenoptera borealis</i>	E	E
Southeastern Beach Mouse	<i>Peromyscus polionotus niveiventris</i>	T	T

Sources: FDACS 2003, FFWCC 2004, USAF 2001

E = Endangered; SSC = Species of Special Concern; T = Threatened  
(S/A) = listed by similarity of appearance to a listed species

Wood storks are year-round residents of the Cape Canaveral area, nesting in treetops of mangrove swamps and near water impoundments. Florida scrub jays use the oak scrub habitat at CCAFS. Least terns typically nest between May and June and use sandy or gravelly beaches and gravel rooftops in an industrial area at CCAFS from April to October. Least terns are sensitive to disturbance during nesting.

Four endangered whale species (finback, humpback, North Atlantic right, and sei) occur in the coastal waters near CCAFS. The NMFS has designated critical habitat for the North Atlantic right whale, which includes marine waters adjacent to the coasts of Georgia and Florida, including the Cape Canaveral area (59 FR 13500).

### 3.1.7 Socioeconomics

Socioeconomic resources in the area surrounding CCAFS include the population, economy, transportation system, public and emergency services, and recreation opportunities. These resources are described below.

#### 3.1.7.1 Population

The regional area consists of six counties: Brevard, Indian River, Orange, Osceola, Seminole, and Volusia. Figure 3-5 highlights population centers located within the six-county region. The largest of these include the Daytona Beach/Port Orange area to the north, the Kissimmee/Orlando/Sanford area and Titusville to the west, and the Melbourne/Palm Bay area to the south. Table 3-5 presents the population for each of the counties in the regional area and the projected populations for 2006.

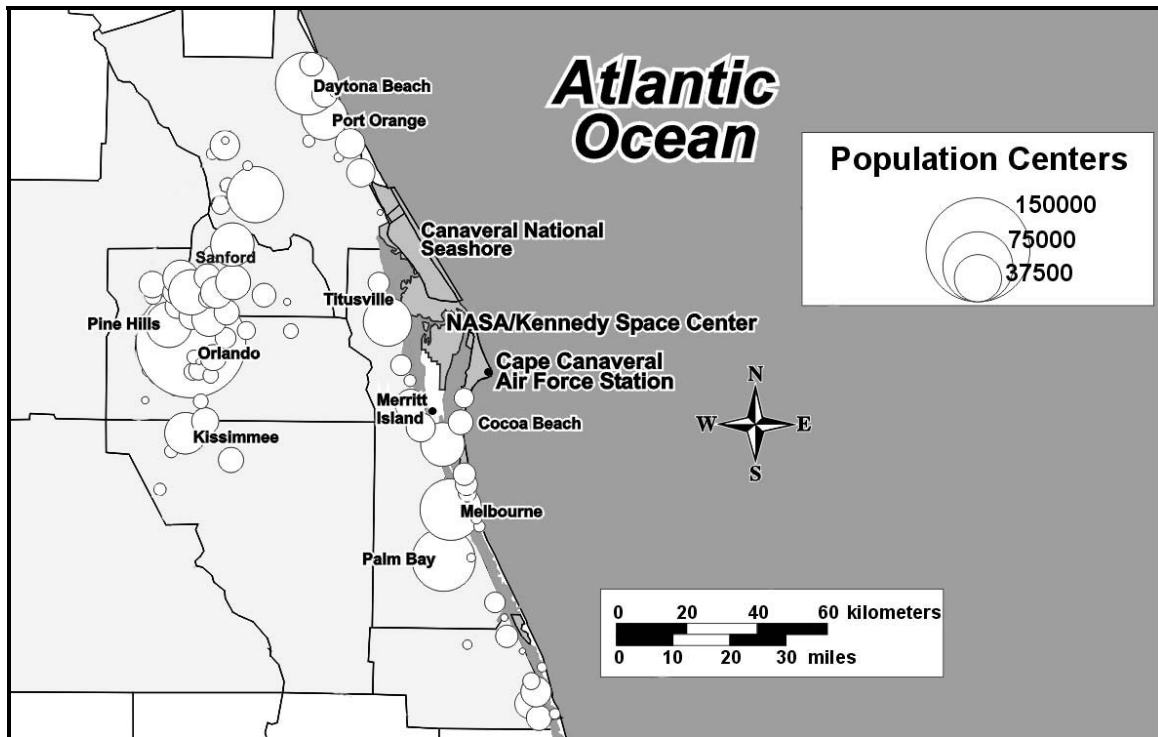

**FIGURE 3-5. POPULATION CENTERS IN THE CCAFS REGIONAL AREA**

**TABLE 3-5. POPULATION OF THE CCAFS REGIONAL AREA**

<b>County</b>	<b>Census Population 2000</b>	<b>Projected Population 2006</b>
Brevard	476,230	519,640
Indian River	112,947	126,299
Orange	896,344	1,042,440
Osceola	172,493	208,720
Seminole	365,196	415,820
Volusia	443,343	485,800
<b>Six-County Region</b>	<b>2,466,553</b>	<b>2,798,719</b>

Sources: USBC 2001, BEBR 2002

Figure 3-6 shows population groups residing within the regional area in 1990 and 2000. The regional population grew at a faster rate than the State's from 1990 to 2000 by 27.6 percent (1,932,646 to 2,466,553), whereas the State's population grew by 23.5 percent (12,937,926 to 15,982,378). The population in Brevard County grew by 19.4 percent (398,978 to 476,230), a lower rate than both the State and the six-county region (USBC 2001). Minorities comprised approximately 19 percent of the total resident population in the six-county region in 1990. Between 1990 and 2000, the minority population in the regional area of interest increased by more than 50 percent, and by 2000, minority persons comprised about 29 percent of the residents (Appendix C).

The six-county region is expected to have population increases through 2006, with a projected population of almost 2.8 million. The population of Brevard County is projected to increase to 519,640 persons in 2006. Orange County is expected to remain the most populated, with a projected population of 1,042,440 persons by 2006.

Persons whose income is less than the poverty threshold are defined as low-income persons by the Council on Environmental Quality (CEQ 1997). In 1990, about 10 percent of the persons living in the regional area of interest reported incomes that were below the 1989 poverty threshold (Appendix C, Table C-1). By the year 2000, 10.7 percent of the persons living in the regional area of interest reported incomes below the 1999 poverty threshold. In 1990, low-income persons comprised less than 10 percent of the population residing within 20 km (12 mi) of the launch complex. That percentage decreased to less than 8 percent by the year 2000. The percentage of persons living in the regional area of interest and whose incomes were below the poverty threshold (10.7 percent) in 2000 was less than the three-year average of 11.9 percent for the United States as a whole (DOC 2001, USBC 2001).

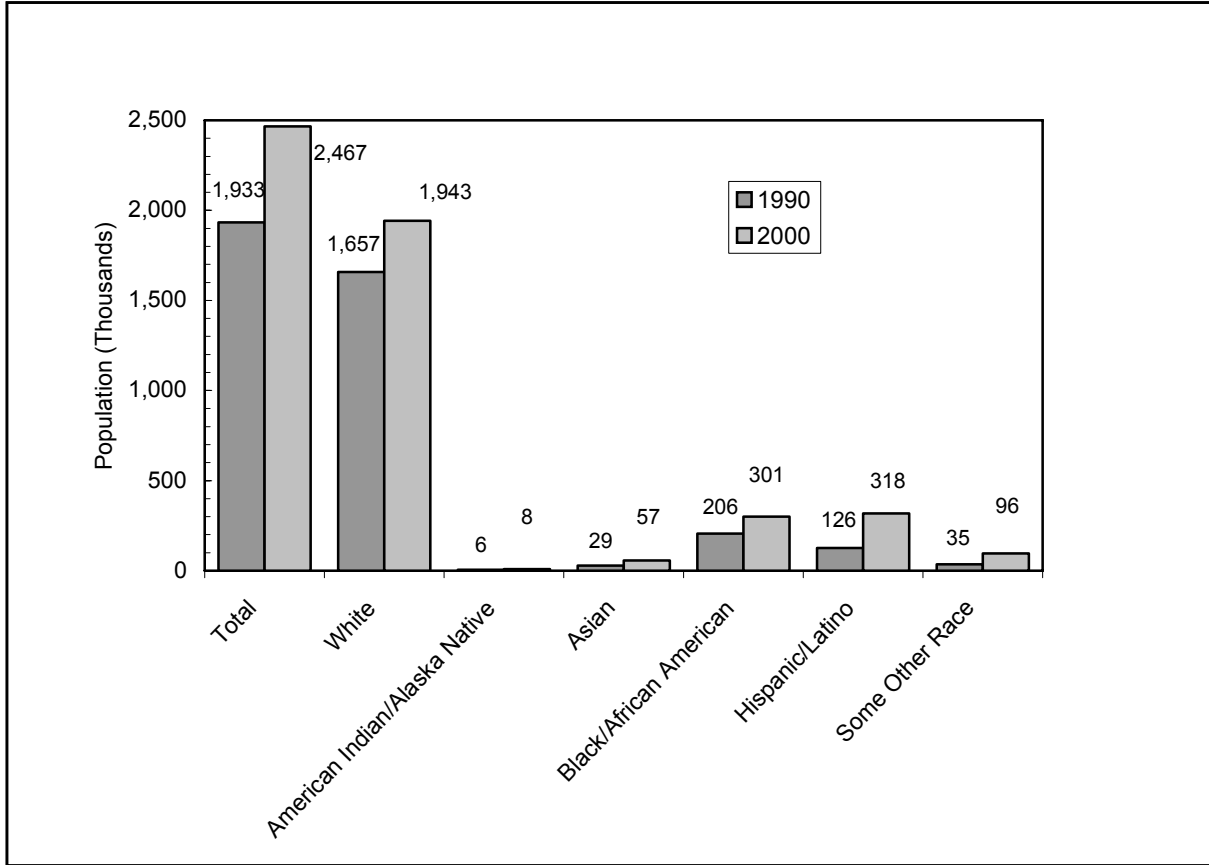

Note: A direct comparison of 1990 Census data and 2000 Census data for minority groups is not possible. During the 2000 Census, the USBC modified its enumerations methodology to include multiracial responses and added a separate racial category, "Native Hawaiian or Other Pacific Islander". As an individual may report more than one race, the aggregate of Population Group may not match the total. For the 1990 census year, the American Indian includes Eskimo or Aleut groups, the Asian includes Pacific Islander groups, the Hispanic/Latino includes Hispanics of any race. For the 2000 census year, the Asian includes Native Hawaiian and other Pacific Islander groups and the Hispanic/Latino includes Hispanics of any race.

**FIGURE 3-6. POPULATION GROUPS IN THE CCAFS REGIONAL AREA**

### 3.1.7.2 Economy

The region's economic base is tourism and manufacturing, with tourism attracting more than 20 million visitors annually. Walt Disney World®, Sea World®, and Universal Studios Florida®, along with KSC, are among the most popular tourist attractions in the State. Several cruise lines anchor at Port Canaveral providing a multimillion-dollar economic boost to Brevard County, and the Port's cargo business is emerging as a major economic contributor to Central Florida.

Industrial sectors in Brevard County providing significant employment in 2000 were services (34.2 percent), wholesale and retail trade (24.3 percent), government (14.3 percent), manufacturing (13.8 percent), construction (5.9 percent), finance, insurance,



and real estate (3.3 percent), transportation, communications and public utilities (2.8 percent), and agriculture and fishing (1.1 percent) (BEBR 2001).

An estimated 1,224,643 people were employed in the regional area in 2000. The unemployment rate for the region in 2000 was estimated at 2.9 percent. Brevard County had 220,413 people employed in 2000 with an unemployment rate of 2.8 percent (USBC 2000, BEBR 2001).

Employment at CCAFS includes about 5,700 military and civilian personnel, all associated with the USAF (Chambers 2003). Most employees are contractor personnel from companies associated with missile testing and launch vehicle operations. Military personnel are attached to the 45th Space Wing at Patrick Air Force Base (PAFB), approximately 32 km (20 mi) south of CCAFS (USAF 2001).

### 3.1.7.3 Transportation Systems

The region is supported by a network of Federal, State and County roads (Figure 3-2). Rail service for freight is available in all six counties, although passenger service is limited. The Florida East Coast Railway provides rail transportation in the CCAFS/KSC area. A main rail line traverses the cities of Titusville, Cocoa, and Melbourne.

The region has three major airports: Orlando International, Daytona Beach International, and Melbourne International. Melbourne International Airport, the closest air transportation facility of the three, is located 48 km (30 mi) south of CCAFS. CCAFS contains a skid strip (runway) for government aircraft and delivery of launch vehicle components. Airfreight associated with the operation of CCAFS launch complexes arrives at the CCAFS skid strip.

Port Canaveral, the nearest navigable seaport to CCAFS, has approximately 480 m (1,600 ft) of dockage. With six cruise terminals and two more planned, Port Canaveral has become the second busiest cruise port in the world (Port Canaveral 2003).

### 3.1.7.4 Public and Emergency Services

Health care in the region is provided at 28 general hospitals, three psychiatric hospitals, and two specialized hospitals. Emergency medical services for CCAFS personnel are provided at the Occupational Health Facility at KSC. Additional health care services are provided by nearby public hospitals located outside of CCAFS.

Nearly 90 percent of the people in the six-county region rely on public systems for potable water. CCAFS obtains its potable water under contract from the City of Cocoa water system and uses up to 3.8 million liters (1 million gallons (gal)) per day (USAF 1998). The Cocoa water system draws its supplies from the Floridan Aquifer. The water distribution system at CCAFS is sized to accommodate the short-term high-volume flows required for launches.

A mutual-aid agreement exists between the City of Cape Canaveral, Brevard County, KSC, and the range contractor at CCAFS for reciprocal support in the event of an emergency or disaster (USAF 1998). Further, CCAFS and the Brevard County Office of

Emergency Management have agreements for communications and early warning in the event of a launch accident.

Range Safety monitors launch surveillance areas to ensure that risks to people, aircraft, and surface vessels are within acceptable limits. Control areas and airspace are closed to the public as required. The USAF is responsible for disseminating a Notice to Aviators through the Federal Aviation Administration (FAA), and air traffic in a FAA-designated area around the launch corridor is controlled. Radar surveillance for intruding aircraft within a 93 km (50 nautical miles) radius of the launch site is conducted beginning 30 minutes prior to a scheduled launch and continuing until the launch is complete. The USAF also ensures that a Notice to Mariners within a predetermined impact debris corridor is disseminated beginning 10 working days prior to a launch. The U.S. Coast Guard transmits marine radio broadcast warnings to inform vessels of the effective closure time for the sea impact debris corridor. In addition, warning signs are posted in various Port Canaveral areas for vessels leaving port (USAF 1998). In addition, PAFB maintains a web site and toll-free telephone number with launch hazard area information for mariners and restricted airspace information for pilots.

#### 3.1.7.5 Recreation

There is an abundance of public recreational opportunities in the six-county region. Recreational activities focus primarily on coastal beaches, inland waterways (e.g., Indian, Banana, and St. Johns River), and freshwater lakes scattered throughout the region. The Canaveral National Seashore lies to the north of CCAFS, and the MINWR, which includes most of KSC, lies immediately to the west. Seven State wildlife management areas, primarily in the St. Johns River basin, are used for hunting small game, turkey, hogs, and deer. Within the confines of CCAFS, the use of recreational activities and facilities is limited to CCAFS personnel. Military and civilian personnel may use recreational and cultural facilities available in local communities.

#### 3.1.7.6 Cultural/Historic/Archaeological Resources

Cultural facilities at CCAFS include the Air Force Space and Missile Museum and the original NASA mission control, and are located at the southern portion of the base.

A 1978 survey of MINWR identified four historic sites: Sugar Mill Ruins, Fort Ann, Dummett Homestead, and the Old Haulover Canal. Of the four sites, only the Old Haulover Canal is listed on the National Register of Historic Places (NRHP) (DOI 2003). No NRHP listed or eligible prehistoric or historic archeological sites have been identified at SLC-41.

Archaeological investigations at CCAFS indicate that human occupation of the area first occurred approximately 4,000 years ago. Federal regulations require that NASA takes into consideration the impact of its activities on cultural resources which are on, or are considered eligible for listing on, the NRHP. Surveys of CCAFS recorded 56 prehistoric and historic archaeological sites, with several identified as eligible for listing on the NRHP. Launch Pads 5/6, 13, 14, 19, 26, 34, and the original Mission Control Center at CCAFS are listed on the NRHP and form a National Historic Landmark District associated with the Man in Space Program. Launch Complexes 1/2, 3/4, 9/10, 17,

21/22, 31/32, and the original site of the Cape Canaveral Lighthouse and the Lighthouse itself are considered as eligible for listing on the NRHP (USAF 2001).

## **3.2 THE GLOBAL ENVIRONMENT**

In accordance with Executive Order 12114, *Environmental Effects Abroad of Major Federal Actions*, this section provides a general overview of the global environment. It includes basic descriptions of the troposphere and stratosphere, global population distribution and density, and the distribution of land surface types. It also briefly discusses background radiation and the global atmospheric inventory of plutonium.

### **3.2.1 Troposphere**

The troposphere is the atmospheric layer closest to the Earth's surface. All life exists and virtually all weather occurs within this layer. Additionally, this layer accounts for more than 80 percent of the mass and essentially all of the water vapor, clouds, and precipitation contained in the Earth's atmosphere. The height of the troposphere ranges from an altitude of 10 km (6 mi) at the poles to 15 km (9 mi) at the equator (Figure 3-7).

In the troposphere, temperature decreases with height at a nominal rate of approximately 6.5° Celsius (°C) per km (about 3.6° Fahrenheit (°F) per 1,000 ft). In general, the troposphere is well mixed and aerosols in the troposphere are removed in a short period of time (ranging from a few days to a few weeks) as a result of both the mixing within this layer and scavenging by precipitation. A narrow region called the tropopause separates the troposphere and the stratosphere.

Emissions from rocket launches include particulate matter, oxides of nitrogen, carbon monoxide, and chlorine compounds. Removal of most of these from the troposphere occurs over a period of less than one week, preventing a buildup of these products on a global level (USAF 1998).

### **3.2.2 Stratosphere**

The stratosphere extends from the tropopause up to an altitude of approximately 50 km (31 mi) (Figure 3-7). In general, vertical mixing is limited within the stratosphere, providing little transport between the layers above and below. Thus, the relatively dry, ozone-rich stratospheric air does not easily mix with the lower, moist ozone-poor tropospheric air. In addition, the lack of vertical mixing and exchange between atmospheric layers provides for extremely long residence times, on the order of months, causing the stratosphere to act as a reservoir for certain types of atmospheric pollution. The temperature is relatively constant in the lower stratosphere and gradually increases with altitude, reaching approximately 3°C (37.5°F) at the top of the layer. This temperature increase is caused primarily by the adsorption of short-wave radiation by ozone molecules.

The USAF has documented estimates of the total annual input of rocket exhaust products to the stratosphere from 23 Atlas, Delta, and Titan launches from CCAFS in 1995 and another 23 launches in 1996 (USAF 1998). The total estimated annual input to the stratosphere from these launches averaged about 376 metric tons (414 tons) per

year of particulate matter, 1.4 metric tons (1.5 tons) per year of NO<sub>x</sub>, 725 metric tons (799 tons) per year of CO, and 188 metric tons (208 tons) per year of chlorine compounds.

The Montreal Protocol is designed to protect the stratospheric ozone layer by phasing out production and consumption of substances that deplete the ozone layer. It was first signed in 1987 and additional requirements were adopted through 1999. Recent measurements indicate that stratospheric chlorine levels are decreasing, consistent with expected declines resulting from the Montreal Protocol.

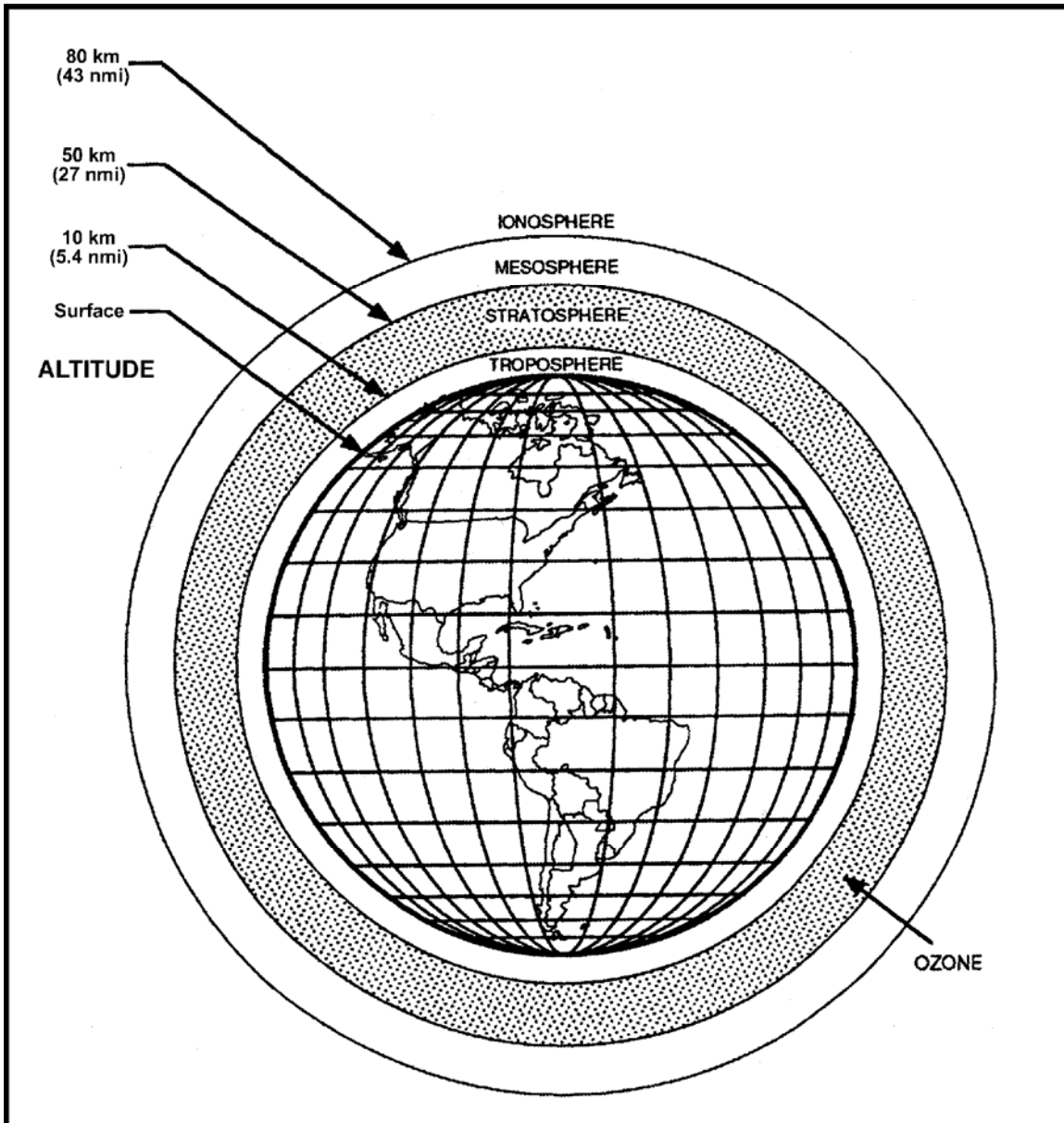

**FIGURE 3-7. ATMOSPHERIC LAYERS AND THEIR ESTIMATED ALTITUDE**

### 3.2.3 Population Distribution and Density

The information used for global demographics was adapted from *World Demographic Update Through 1990 for Space Nuclear System Safety Analysis*, prepared for the U.S. Department of Energy (DOE) by Halliburton NUS Environmental Corporation (HNUS 1992). This document used world-wide population statistics and other information distributed among 720 cells of equal size. The cells were derived by dividing the Earth from pole to pole into 20 latitude bands of equal area. Each latitude band was then segmented into 36 equal size cells, for a total of 720 cells. Each of the cells covered an area of 708,438 square kilometers (km<sup>2</sup>) (273,528 square miles (mi<sup>2</sup>)). The 1990 population estimates in the document were increased by a factor of 1.356 to provide population estimates for 2006 (Bartram 2004).

Table 3-6 lists the distribution of the Earth's projected population for 2006 across each of the 20 equal-area latitude bands. The greatest population densities occur in a relatively narrow grouping of the four northern bands between latitudes 44° North and 17° North (bands 4 through 7).

**TABLE 3-6. GLOBAL POPULATION AND SURFACE CHARACTERISTICS BY LATITUDE BAND**

Latitude Band	Band Population Estimate for 2006	Population Density <sup>(a)</sup> persons/km <sup>2</sup> (persons/mi <sup>2</sup> )	Band Surface Fractions			
			Water	Land	Land Rock Fraction	Land Soil Fraction
1	8.23x10 <sup>7</sup>	12.1 (31.4)	0.7332	0.2668	1.0 <sup>(b)</sup>	0.0 <sup>(b)</sup>
2	2.73x10 <sup>8</sup>	18.1 (46.9)	0.4085	0.5915	1.0 <sup>(b)</sup>	0.0 <sup>(b)</sup>
3	7.28x10 <sup>8</sup>	51.5 (133.5)	0.4456	0.5544	0.251 <sup>(b)</sup>	0.749 <sup>(b)</sup>
4	1.08x10 <sup>9</sup>	94.6 (244.7)	0.5522	0.4478	0.251	0.749
5	1.13x10 <sup>9</sup>	103.8 (269.1)	0.5718	0.4282	0.153	0.847
6	1.20x10 <sup>9</sup>	119.7 (309.4)	0.6064	0.3936	0.088	0.912
7	8.58x10 <sup>8</sup>	102.2 (264.9)	0.6710	0.3290	0.076	0.924
8	4.88x10 <sup>8</sup>	77.0 (199.2)	0.7514	0.2486	0.058	0.924
9	4.49x10 <sup>8</sup>	73.1 (189.6)	0.7592	0.2408	0.077	0.923
10	2.70x10 <sup>8</sup>	49.4 (128.2)	0.7854	0.2146	0.084	0.916
11	2.70x10 <sup>8</sup>	44.7 (115.5)	0.7630	0.2370	0.044	0.956
12	1.66x10 <sup>8</sup>	29.9 (77.3)	0.7815	0.2185	0.055	0.945
13	1.10x10 <sup>8</sup>	19.6 (50.8)	0.7799	0.2201	0.085	0.915
14	1.15x10 <sup>8</sup>	18.6 (48.3)	0.7574	0.2426	0.089	0.911
15	7.32x10 <sup>7</sup>	13.0 (33.7)	0.7796	0.2204	0.092	0.980
16	7.81x10 <sup>7</sup>	22.6 (58.6)	0.8646	0.1354	0.112	0.888
17	1.40x10 <sup>7</sup>	11.8 (30.7)	0.9538	0.0462	0.296	0.704
18	6.26x10 <sup>6</sup>	11.3 (29.4)	0.9784	0.0216	0.296 <sup>(b)</sup>	0.704 <sup>(b)</sup>
19	1.01x10 <sup>6</sup>	5.6 (14.6)	0.9930	0.0070	1.0 <sup>(b)</sup>	0.0 <sup>(b)</sup>
20	< 10 <sup>4</sup>	<0.001 (<0.002)	0.3863	0.6137	1.0 <sup>(b)</sup>	0.0 <sup>(b)</sup>

Source: Adapted from HNUS 1992

- (a) Population density on land fraction.
- (b) Assumed values.

### 3.2.4 Surface Types

The worldwide distribution of surface types is an important characteristic in considering the potential consequences of accident scenarios. Table 3-6 provides a breakdown of the total land fraction for each of the 20 latitude bands. The total land fraction was further subdivided by the fraction consisting of soil or rock cover. For the most densely populated bands (bands 4 through 7), the land fraction varies from about 33 percent in band 7 to about 45 percent in band 4, with the soil fraction dominating (from about 75 percent in band 4 to about 92 percent in band 7).

### 3.2.5 Background Radiation

#### 3.2.5.1 Natural and Manmade Sources

The general population is exposed to various sources of natural and manmade radiation. These sources are divided into six broad categories: (1) cosmic radiation (from space), (2) external terrestrial radiation or groundshine (from naturally occurring radiation in rocks and soil), (3) internal radiation (from inhalation or ingestion), (4) consumer products (from smoke detectors, airport x-ray machines, televisions), (5) medical diagnosis and therapy (diagnostic x-rays, nuclear medical procedures), and (6) other sources (nuclear power plants, transportation, emissions from power stacks).

Dose is the amount of ionizing radiation energy deposited in body tissues via the applicable exposure pathways and is expressed in units of measurement called rems. An average person in the United States receives a total dose of about 0.36 rem per year from all of these sources (see Table 3-7). The largest dose, about 66 percent of the yearly total, is received from internal radiation, where exposure has occurred as a result of inhalation or ingestion of radioactive material. Exposure to radon, the largest component of internal radiation, accounts for about 55 percent or 0.2 rem of the yearly total dose received. Exposure to cosmic radiation and groundshine collectively, is about 15 percent of the yearly total dose, the same percentage contributed from medical diagnosis and therapy. The average yearly dose from consumer products is about 3 percent. For perspective, a modern x-ray results in a dose of about 0.006 rem and about 0.065 rem is received from a diagnostic pelvic and hip x-ray (DOE 2000).

#### 3.2.5.2 Worldwide Plutonium Levels

Plutonium-238 (Pu-238) exists in the environment as a result of atmospheric testing of nuclear weapons and a 1964 launch accident. The following information provides a perspective against which to compare the scope of postulated incremental releases of plutonium from potential mission accidents.

Between 1945 and 1974, aboveground nuclear weapons tests released about 440,000 curies (Ci) of plutonium to the environment (AEC 1974). About 97 percent (about 430,000 Ci) of this plutonium was Pu-239 and Pu-240, essentially identical isotopes with respect to chemical behavior and radiological emission energies. The remainder (about 10,000 Ci) consists primarily of about 9,000 Ci of Pu-238, along with much smaller amounts of Pu-241 and Pu-242. (Some of the Pu-238 and Pu-241 has decayed since the time of release.)

**TABLE 3-7. AVERAGE ANNUAL EFFECTIVE DOSE EQUIVALENT OF IONIZING RADIATION TO A MEMBER OF THE U.S. POPULATION**

Source	Effective Dose Equivalent <sup>(a)</sup>	
	rem per year	percent of total
Natural		
Radon <sup>(b)</sup>	0.2	55
Cosmic	0.027	8
Terrestrial	0.028	8
Internal	0.039	11
Subtotal — Natural	0.3	82
Manmade		
Medical		
X-ray diagnosis	0.039	11
Nuclear medicine	0.014	4
Consumer products	0.010	3
Other		
Occupational	< 0.001	< 0.03
Nuclear fuel cycle	< 0.001	< 0.03
Fallout	< 0.001	< 0.03
Miscellaneous <sup>(c)</sup>	< 0.001	< 0.03
Subtotal — Manmade	0.064	18
<b>Total Natural and Manmade <sup>(d)</sup></b>	<b>0.364</b>	<b>100</b>

Source: NCRP 1987

- (a) Effective dose equivalent is proportional to incremental risk in cancer
- (b) Dose equivalent to bronchi from radon decay products. The assumed weighting factor for the effective dose equivalent relative to whole-body exposure is 0.08.
- (c) U.S. Department of Energy facilities, smelters, transportation, etc.
- (d) The 50-year effective dose commitment is 50 years times 0.364 rem per year, or 18.2 rem.

Pu-238 in the atmosphere from weapons tests (about 9,000 Ci) was increased by the 1964 reentry and burnup of a Systems for Nuclear Auxiliary Power (SNAP)-9A radioisotope thermoelectric generator (RTG), which released 17,000 Ci. This release into the atmosphere was consistent with the RTG design philosophy of the time. Since 1964, essentially all of the Pu-238 released from SNAP-9A has been deposited on the Earth's surface (AEC 1974). About 25 percent (approximately 4,000 Ci) of that 1964 release was deposited in the northern hemisphere, with the remaining 75 percent settling in the southern hemisphere. In April 1986, approximately 100,000,000 Ci of various radioisotopes were released to the environment from the

Chernobyl nuclear power station accident (NRC 1987). Approximately 810 Ci were Pu-238.

The total plutonium released to the ocean environment by overseas nuclear reprocessing plants between 1967 and 1987 was approximately 20,000 Ci (IAEA 1976, NCRP 1987, UNSCEAR 1988). Assuming that 15 percent of the total was Pu-238 (based upon the 1980-85 fraction in Great Britain's Sellafield releases), about 3,000 Ci of Pu-238 have been added from these sources, bringing the total of Pu-238 dispersed into the environment up to about 29,810 Ci.



## 4 ENVIRONMENTAL CONSEQUENCES

This Chapter of the Final Environmental Impact Statement (FEIS) for the New Horizons mission presents information on the potential environmental impacts of an Atlas V 551 launch. The impacts are examined for two areas: (1) the local area surrounding Cape Canaveral Air Force Station (CCAFS), Florida, and (2) the global environment.

### 4.1 ENVIRONMENTAL IMPACTS OF THE PROPOSED ACTION

The National Aeronautics and Space Administration (NASA) proposes to continue preparations for and to implement the New Horizons mission to Pluto and its moon, Charon, and to the Kuiper Belt that lies beyond Neptune's orbit. The New Horizons spacecraft would perform science observations of Pluto and Charon as it flies past these bodies, and could be directed to perform similar science observations as it flies past one or more Kuiper Belt Objects (KBO).

The New Horizons spacecraft would be launched on an Atlas V 551 launch vehicle from Space Launch Complex-41 (SLC-41) at CCAFS. The primary launch opportunity occurs in January – February 2006, with arrival of the spacecraft at Pluto as early as 2015. A backup launch opportunity could occur during February 2007, with arrival at Pluto in either 2019 or 2020, depending on the exact launch date.

This section of the FEIS first presents the environmental impacts of preparing for launch and the environmental impacts resulting from a normal launch event. These impacts are summarized in Sections 4.1.1 and 4.1.2, respectively. Environmental impacts associated with Atlas launches from CCAFS have been previously addressed in the U.S. Air Force's (USAF) *Final Environmental Impact Statement for the Evolved Expendable Launch Vehicle Program* (USAF 1998) and *Final Supplemental Environmental Impact Statement for the Evolved Expendable Launch Vehicle Program* (USAF 2000) and in NASA's *Final Environmental Assessment for Launch of NASA Routine Payloads on Expendable Launch Vehicles from Cape Canaveral Air Force Station, Florida and Vandenberg Air Force Base, California* (NASA 2002). The USAF has assessed environmental impacts of Atlas V launches through 2020 based upon an annual average launch rate of 10 launches per year from CCAFS (USAF 2000). Launch of the Atlas V for the New Horizons mission would be included in and not increase this previously approved launch rate.

The potential nonradiological environmental impacts of a launch accident are discussed in Section 4.1.3. Section 4.1.4 addresses radiological impacts which may result from a launch accident.

As shown in Figure 4-1, the most likely outcome of implementing the New Horizons mission (938 out of 1,000) is a successful launch of the spacecraft to Pluto. If, however, a launch accident were to occur, such an unlikely accident is not expected to result in a release of the plutonium dioxide (PuO<sub>2</sub>) in the radioisotope thermoelectric generator (RTG).

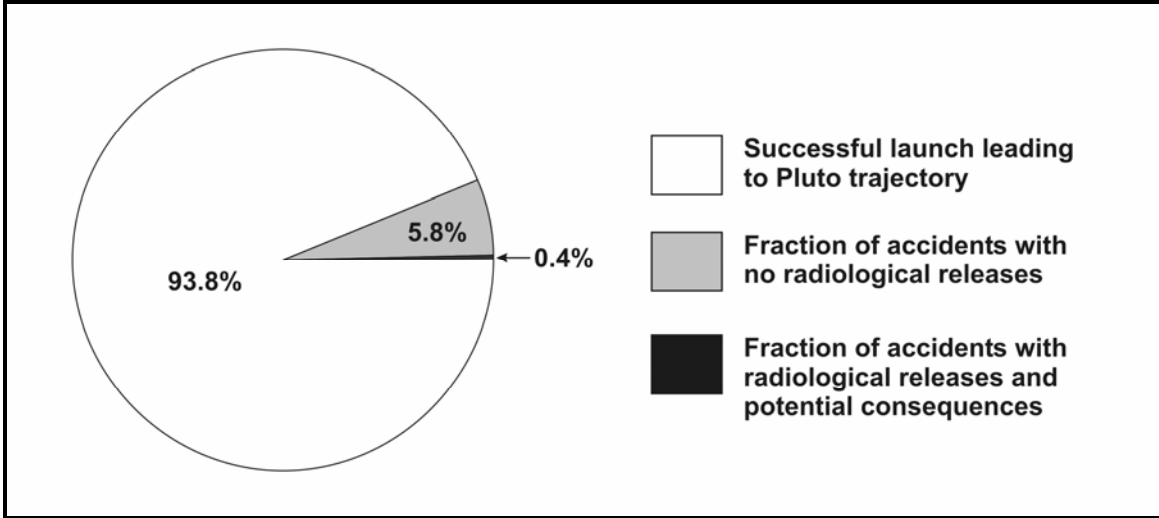

Source: Adapted from DOE 2005

**FIGURE 4-1. LAUNCH-RELATED PROBABILITIES**

Various sections of this FEIS refer to a launch success probability of approximately 94 percent for the New Horizons Atlas V launch vehicle. This is an estimate for the vehicle to successfully complete all pre-launch operations, first stage flight, Centaur second stage flight, third stage flight, and conclude with successful insertion of the spacecraft into the proper Earth escape trajectory. The methodology used to calculate this estimate utilized flight histories of all United States and Russian launch vehicles flown since 1988. This flight history consists of earlier versions of Atlas and Titan launch vehicles manufactured by the Lockheed Martin Corporation, Delta launch vehicles manufactured by the Boeing Aerospace Company, and Zenit and Energia launch vehicles manufactured by Russian aerospace companies. This is done to provide some assurance to the estimate that all past applicable and partially applicable flight failure experiences are considered in the reliability estimate of the Atlas V launch vehicle for the New Horizons mission. This estimate therefore does not necessarily reflect the demonstrated reliability of the Atlas V, which in fact may be higher. This analytical approach for the overall mission launch reliability is considered by NASA to be conservative, and is based upon the best available information at the time of the analysis. NASA continues to evaluate the mission launch reliability analysis. The Atlas V is a new configuration of the Atlas family of launch vehicles, and there have been three successful flights of Atlas V vehicles to date. The results of NASA's continuing evaluations may eventually be different from the results presented in this FEIS as the Atlas V completes additional launches scheduled prior to the proposed New Horizons launch in 2006. Successful completion of those scheduled missions would be expected to produce an increase to the reliability estimate of the Atlas V launch vehicle for the New Horizons mission reported in this FEIS.

**4.1.1 Environmental Consequences of Preparing for Launch**

Launch activities for the New Horizons mission would be subject to Federal, State, and local environmental laws and regulations, and USAF regulations and requirements (see

Section 4.8). Atlas launch vehicles are routinely launched from CCAFS and processing the launch vehicle for the New Horizons mission would be considered a routine activity.

Payload and launch vehicle processing at Kennedy Space Center (KSC) and CCAFS would involve a number of industrial activities that include the use of hazardous materials, and would generate hazardous wastes, other solid and liquid wastes, and air emissions. Such material would include but not be limited to propellants, oils, solvents, primers, sealants, and process chemicals. NASA or its contractors would acquire hazardous materials and would dispose generated hazardous wastes. In addition, CCAFS has programs for pollution prevention and spill prevention. Airborne emissions from liquid propellant loading and off-loading of spacecraft and launch vehicles are closely monitored using vapor detectors. Systems for loading hypergolic fuels (which ignite spontaneously when mixed) use air emission controls (USAF 1998). Thus, processing the spacecraft and Atlas V launch vehicle for the New Horizons mission is not expected to cause adverse environmental impacts.

Some spacecraft and launch vehicle integration personnel could be exposed to radiation during pre-launch testing and integration of the RTG to the New Horizons spacecraft. Integration and launch processing activities involving ionizing and non-ionizing radiation at KSC and CCAFS are subject to extensive review and authorization of all activities by the local radiation protection authority prior to initiation of any operation. Such operations are actively monitored by launch site radiation safety personnel to ensure adherence to approved operating and emergency procedures and to maintain operational personnel exposures at levels that are as low as reasonably achievable (USAF 1999, NASA 2001).

#### 4.1.2 Environmental Impacts of a Normal Launch

The primary environmental impacts of a normal launch of the New Horizons mission on an Atlas V 551 would be associated with airborne exhaust emissions from propellant combustion, particularly from the solid propellant in the solid rocket boosters (SRB). Exhaust from the liquid propellant first stage of the Atlas V (consisting of rocket propellant-1 (RP-1) and liquid oxygen (LO<sub>2</sub>)) would have relatively minor impacts.

##### 4.1.2.1 Land Use

CCAFS is designated a Federal entity and has its own land use and zoning regulations. Brevard County and the City of Cape Canaveral have jurisdiction over the land areas adjacent to CCAFS and the general plans of Brevard County and the City of Cape Canaveral designate compatible land uses around CCAFS. Land areas on and around SLC-41 are currently within the launch operations land use category. Therefore, launch of an Atlas V is consistent with the designated land uses of CCAFS and KSC (USAF 1998, NASA 2003).

##### 4.1.2.2 Air Quality

Rocket launches are discrete events that can cause short-term impacts on local air quality from launch vehicle exhaust emissions. Winds would rapidly disperse and dilute the launch emissions to background concentrations. After ignition of the first stage and

the first few seconds of liftoff through launch vehicle ascent, the exhaust emissions would form a buoyant cloud at the launch pad. This high-temperature cloud would rise quickly and stabilize at an altitude of a few hundred meters near the launch area. The cloud would then dissipate through mixing with the atmosphere. The exhaust products would be distributed along the launch vehicle's trajectory as the vehicle moves through the atmosphere. Airborne emissions from a normal launch at CCAFS would not be expected to result in adverse impacts to the off-site public (USAF 1998, USAF 2000). The nearest residential areas to SLC-41 at CCAFS are about 13 to 16 kilometers (km) (8 to 10 miles (mi)) to the south in the cities of Cape Canaveral and Cocoa Beach.

Exhaust emissions would occur over a period of minutes as the launch vehicle ascends through the atmosphere. Exhaust emissions occurring up to an altitude of about 9,150 meters (30,000 feet) from the surface are typically considered lower atmospheric emissions. A normal Atlas V launch would result in combustion emissions from the first stage main engine and the SRBs. The Atlas V main engine primarily produces carbon monoxide (CO), carbon dioxide (CO<sub>2</sub>), water vapor, oxides of nitrogen (NO<sub>x</sub>), and carbon particulates as combustion products. The Atlas V SRBs primarily produce oxidation products of aluminum oxide (Al<sub>2</sub>O<sub>3</sub>), CO, hydrogen chloride (HCl), and nitrogen (N<sub>2</sub>). Under the high temperatures of the SRB's exhaust the CO would be quickly oxidized to CO<sub>2</sub>, and the N<sub>2</sub> may react with ambient oxygen to form nitrogen oxides (NO<sub>x</sub>). Most of these emissions would be removed from the atmosphere over a period of less than one week, yielding no long-term accumulation of these products (USAF 1998).

Previous analyses have shown that emissions from a normal launch of an Atlas V with SRBs would not create long-term adverse impacts to air quality in the region (USAF 2000). The entire State of Florida, and therefore the CCAFS area, is in attainment for all National Ambient Air Quality Standards (NAAQS) constituents (see Table 3-2), including the proposed PM<sub>2.5</sub> fine particle standard based on preliminary data (FDEP 2002, 69 FR 23857). Based on the USAF findings cited above, emissions from launch of the New Horizons mission at CCAFS would not be sufficient to jeopardize the attainment status of the region.

#### 4.1.2.3 Noise

Estimated noise levels for an Atlas V have been previously reported (USAF 1998, USAF 2000). Noise impacts associated with launches occur due to sound from the launch pad from ignition through lift-off. Increased noise levels would occur for only a short period (typically less than two minutes) during the vehicle's early ascent, and diminish rapidly as the vehicle gains altitude and moves downrange (USAF 1998).

Based on modeling, the overall sound pressure level at the launch site for a typical Atlas V 551 launch would be about 130 decibels (dBA) (USAF 2000). Non-essential workers would be removed from the launch area prior to the New Horizons liftoff, and those remaining would be exposed to noise levels anticipated to be below Occupational Safety and Health Administration regulations for unprotected workers (140-dBA maximum and 115-dBA over a 15-minute average).

During an Atlas V launch, the noise levels at the nearest communities (Cape Canaveral and Cocoa Beach, both to the south about 13 to 16 km (8 to 10 mi) from the launch pad) have been estimated to be in the 70 to 73 dBA range (USAF 2000). While some area residents may be momentarily annoyed by noise during the New Horizons launch, such noise would be transient and would present no health hazard.

Sonic booms would be generated by normal launch of the New Horizons Atlas V, but would occur offshore over the Atlantic Ocean. No adverse impact to human populations would be expected. Ships and other vessels in the area would be warned in advance of the launch event and would not be adversely affected (USAF 1998).

#### 4.1.2.4 Geology and Soils

The New Horizons Atlas V launch would result in deposition of solid rocket exhaust products (primarily  $\text{Al}_2\text{O}_3$  particulates and HCl) onto soils. Deposition of  $\text{Al}_2\text{O}_3$  in the form of dust would occur primarily in the vicinity of the launch complex, but depending on the particle size distribution and winds, appreciable deposition could also occur downwind. Wet deposition of HCl could occur as exhaust chlorides mix with entrained deluge water and with water contained in the exhaust of the first stage engine. The majority of HCl, however, would be swept into the flame trench at the launch pad. Wet deposition of chlorides would be limited to within a few hundred meters of the launch pad and could temporarily increase acidification of soil. If a rainstorm passes through the exhaust cloud shortly after launch, wet HCl deposition could occur at further distances from the launch complex. The soils at CCAFS are well buffered, however, and are not expected to be adversely affected (Schmalzer et al. 1998, USAF 1998). No long-term adverse impacts to geology or soils at CCAFS would be expected from the New Horizons launch.

#### 4.1.2.5 Hydrology and Water Quality

About 2.27 million liters (600,000 gallons) of water are used during launch of an Atlas V for cooling, acoustic damping, post-launch washdown, fire suppression, and potable uses. Groundwater and surface water resources and water quality could be potentially impacted by the disposal of water used for a launch, and by the deposition of launch exhaust products into nearby surface water bodies.

Groundwater. The City of Cocoa, which pumps water from the Floridan Aquifer, is contracted to supply water to CCAFS and Patrick Air Force Base. The City of Cocoa has sufficient capacity to supply sources to meet usage demands for launch of the New Horizons mission.

Water used at SLC-41 during the launch would be collected and treated, if necessary, prior to being released to grade in accordance with a Florida Department of Environmental Protection wastewater discharge permit, or released to the wastewater treatment plant. The water discharged to grade would percolate through soil to the groundwater table and flow west towards the Banana River (USAF 1998). The water would be further neutralized during its passage through the soil, such that some of the contaminants not removed during treatment would also be removed. It is not expected that groundwater quality would be substantially affected by this discharge of water.

Surface Water. Depending on meteorological conditions, the Atlas V exhaust cloud could drift over the Atlantic Ocean or the Banana River. Surface waters in the immediate area of the exhaust cloud might acidify from deposition of HCl if a rainstorm passes through the exhaust cloud. The large volumes of water bodies in the vicinity of CCAFS, combined with their natural buffering capacity, suggest that the increased acidity caused by HCl deposition would return to normal levels within a few hours (USAF 1996).  $\text{Al}_2\text{O}_3$  particulates would also settle from the exhaust cloud.  $\text{Al}_2\text{O}_3$  particulates are relatively insoluble in local surface waters and would settle out of the water column as sediment. Long-term elevation of aluminum levels in the water column would not be expected.

No long-term adverse impacts to hydrology or water quality would be expected due to a normal launch of the New Horizons mission.

#### 4.1.2.6 Offshore Environment

The offshore environments at CCAFS would be impacted by the jettisoned launch vehicle sections (i.e., the depleted first stage, payload fairing (PLF), and SRB casings) in pre-approved drop zones (see Section 4.1.2.11). Any small amounts of residual propellants would be released to the surrounding water. Metal parts would eventually corrode, but toxic concentrations of the metals would be unlikely because of the slow rate of the corrosion process and the large volume of ocean water available for dilution. Since RP-1 is only weakly soluble in water, any residual RP-1 fuel in the first stage would form a localized surface film which would evaporate within hours. The residual propellant in the SRB casings would dissolve slowly and should not reach toxic concentrations except in the immediate vicinity of the casings (USAF 1998).

#### 4.1.2.7 Biological Resources

Biological resources are not expected to be adversely affected by the New Horizons Atlas V launch except for those fauna and flora in the immediate vicinity of SLC-41. Impacts to vegetation from other launch vehicles (e.g., Atlas II, Delta II, Titan IVB) were observed up to about 800 m (2,625 ft) from the launch pads. Potential impacts from the Atlas V could include scorched vegetation, ground fires, and partial to nearly complete defoliation of trees within 70 to 100 m (230 to 328 ft). Acidic deposition and high temperatures from the exhaust cloud could damage or kill biota within the immediate vicinity of the launch pad, however, long-term population effects on terrestrial biota would not be expected. Jettisoned launch vehicle sections (the SRB casings, first stage, and PLF) that land in the ocean would be subject to corrosion and release of residual propellant. However, it is unlikely that these vehicle sections would have an adverse impact on marine species.

Terrestrial and Aquatic Biota. Short-term impacts to terrestrial fauna and flora in the immediate vicinity of the launch complex could be expected due to the New Horizons launch. Aquatic biota in nearby water bodies, such as the Banana River and the near-shore areas of the Atlantic Ocean, should not be adversely affected by acidic deposition from the exhaust cloud (USAF 1996). A fish kill occurs after most Space Shuttle launches from KSC as a direct result of surface water acidification (Schmalzer et al.

1998). However, there have been no fish kills reported in either the Banana River or the near-shore areas of the Atlantic Ocean from HCl and Al<sub>2</sub>O<sub>3</sub> deposition from normal launch of a Delta II (NASA 1995b). Since the Atlas V for the New Horizons mission would use about one fifth the quantity of solid propellant used by the Space Shuttle, fish kills would not be anticipated.

During the launch, wildlife in the vicinity of the launch site would be temporarily disturbed due to noise, generally amounting to a startling effect. Marine species could be impacted by sonic booms, however the effects of such impacts are not clearly known (USAF 1998, USAF 2000). Because launches are infrequent events, no long-term impacts would be anticipated on wildlife and marine species from noise from the New Horizons launch.

Threatened or Endangered Species. No scrub jay mortality would be expected from the New Horizons launch, based on studies during and following Titan IV launches from SLC-41 in 1990. Fire started by a launch in 1990 caused extended jay scolding behavior and the scrub jays avoided the burned area for about one month (USAF 1998). Other bird species, such as wood storks and bald eagles, may be temporarily disturbed, but no long-term effects would be anticipated.

Sea turtles are sensitive to lighting near nesting beaches. If lighting inland is brighter than the reflected light of the moon and stars on the ocean, hatchlings may become confused, head the wrong way, and never reach the water. Sea turtle nesting typically occurs from May through October, and CCAFS has a light management plan that addresses mitigation of impacts to nesting sea turtles during night-time launches (USAF 1998). Because the New Horizons mission's primary and backup launch periods occur in January and February and the launch would occur during daylight hours, impacts to nesting sea turtles would not be anticipated.

#### 4.1.2.8 Socioeconomics

Launch of the proposed New Horizons mission from CCAFS would be part of the normal complement of launches at CCAFS. Thus, a single launch would result in negligible impacts to socioeconomic factors such as demography, employment, transportation, and public or emergency services.

#### 4.1.2.9 Environmental Justice

Launch of the proposed New Horizons mission would not be anticipated to result in disproportionately high and adverse impacts to low income or minority populations. Further details are presented in Appendix C.

#### 4.1.2.10 Cultural/Historic/Archaeological Resources

No cultural or archaeological resources would be impacted, nor are there buildings or sites that are listed or eligible for listing in the National Register of Historic Places, at SLC-41 (USAF 2000).

#### 4.1.2.11 Health and Safety

At CCAFS, procedures would be in place for the New Horizons mission launch operations, and would include considerations for a normal launch, launch-related accidents, fire protection, alarm, fire suppression, flight termination, and explosive safety (USAF 1998, USAF 2000). Using procedures established for existing launch systems, risks to installation personnel and the general public would be minimized to acceptable levels during both a normal and aborted launch, in accordance with the USAF's *Range Safety User Requirements Manual* (USAF 2004).

The most significant potential health hazard during the New Horizons launch would be exposure to HCl emitted from the SRBs. Range Safety at CCAFS would use models to predict launch hazards to the public and on-site personnel prior to the launch. These models calculate the risk of injury resulting from toxic exhaust gases from normal launches, and from potentially toxic concentrations due to a failed launch. The launch could be postponed if the predicted collective public risk of injury from exposure to toxic exhaust gases exceeds acceptable limits (USAF 2004). This approach takes into account the exhaust plume's concentration, direction, and dwell time, and emergency preparedness procedures (USAF 2000).

Range Safety would monitor launch surveillance areas to ensure that risks to people, aircraft, and surface vessels are within acceptable limits. For the New Horizons mission, a launch trajectory would be created and modified to ensure safety on the ground and at sea, and control areas and airspace would be closed to the public as required. The underlying areas at risk from falling debris or jettisoned stages would be cleared until all launch operations are completed. The SRB casings would land closest to shore, in pre-approved drop zones centered at distances of approximately 230 km (143 mi) from shore. PLF sections and the first stage would land much further from shore, also in pre-approved drop zones (USAF 2000). These distances would be highly dependent on the specific New Horizons launch trajectory characteristics, and other factors such as wind effects.

The USAF would disseminate a Notice to Aviators through the Federal Aviation Administration (FAA), and air traffic in a FAA-designated area around the launch corridor would be controlled. Radar surveillance for intruding aircraft within a 93 km (50 nautical miles) radius of the launch site would be conducted beginning 30 minutes prior to the scheduled launch and continue until the launch is complete. The USAF also would ensure that a Notice to Mariners within a predetermined impact debris corridor is disseminated beginning 10 working days prior to launch. The U.S. Coast Guard would transmit marine radio broadcast warnings to inform vessels of the effective closure time for the sea impact debris corridor. Warning signs would be posted in various Port Canaveral areas for vessels leaving port (USAF 1998). In addition, Patrick Air Force Base would maintain a web site and toll-free telephone number with launch hazard area information for mariners and restricted airspace information for pilots.

#### 4.1.2.12 Global Environment

This section briefly summarizes the potential for the normal launch of an expendable vehicle to contribute to ozone depletion and global climate change. Launch of the New



Horizons Atlas V would not be expected to make substantial contributions to the amounts of ozone-depleting chemicals or greenhouse gases in the atmosphere.

Troposphere. Launch of the proposed New Horizons mission would result in the deposition of exhaust products released along the launch vehicle's trajectory as it ascends through the troposphere. Exhaust products would mostly include HCl, NO<sub>x</sub>, and Al<sub>2</sub>O<sub>3</sub> particulates from the SRBs, and CO, CO<sub>2</sub>, NO<sub>x</sub>, and water vapor from stages using liquid propellants. While there could be ground-level impacts from these products, deposition of small quantities of some exhaust products in the troposphere could contribute to conditions such as global climate change. However, this material would be removed from the troposphere in a short period of time.

Stratosphere. Launch of the New Horizons mission would result in the deposition of small quantities of ozone-depleting chemicals from the combustion products released along the launch vehicle's trajectory through the stratosphere up to an altitude of about 50 km (31 mi). Because of uncertainties about the current loading of ozone-depleting chemicals in the stratosphere, the effects of a launch can be more accurately calculated as a percent increase in the rate of stratospheric ozone depletion relative to a launch not occurring.

Solid rocket motors use ammonium perchlorate as an oxidizer and chlorine compounds are released during combustion, which are the principal contributors to stratospheric ozone depletion from launch vehicles. The principal ozone-depleting chemicals in exhaust emissions from an Atlas V with SRBs would be HCl, NO<sub>x</sub>, and Al<sub>2</sub>O<sub>3</sub> particulates. The ozone depletion rates associated with each of these exhaust products have been previously estimated to be 3.1x10<sup>-5</sup> percent per metric ton (mt) (2.8x10<sup>-5</sup> percent per ton) for HCl emissions, 1.8x10<sup>-6</sup> percent per mt (1.6x10<sup>-6</sup> percent per ton) of NO<sub>x</sub>, and 8.3x10<sup>-6</sup> percent per mt (7.5x10<sup>-6</sup> percent per ton) of Al<sub>2</sub>O<sub>3</sub> (Jackman et al. 1998). NO<sub>x</sub> contributes to destroying stratospheric ozone about 17 times less than HCl and about 4.5 times less than Al<sub>2</sub>O<sub>3</sub> (Jackman 1998). The depletion rates for NO<sub>x</sub>, HCl, and Al<sub>2</sub>O<sub>3</sub> have been used in combination with the estimated mass of combustion products potentially emitted to the stratosphere by various launch vehicles to develop an estimate of annual average global ozone depletion (USAF 1998, USAF 2000, NASA 2002). While a large fraction of launch emissions would occur in the lower atmosphere and not reach the stratosphere, the estimates were based on a conservative assumption that all emissions occurred in the stratosphere. The annual average ozone depletion rate for the normal launch of an Atlas V with SRBs has been estimated to be almost zero (USAF 2000).

Exhaust products from SRBs have greater potential for stratospheric ozone depletion than exhaust products from liquid propelled motors. Therefore, impacts from SRBs have been studied more extensively than impacts from liquid propellant motors.

Global Climate Change. Solar energy is absorbed by the Earth and a portion of this energy is radiated back to space. Global warming occurs when increasing concentrations of certain gases (called greenhouse gases) in the atmosphere trap the re-radiated solar energy within the atmosphere causing the Earth's average surface temperature to rise. Examples of greenhouse gases are water vapor, CO<sub>2</sub>, methane, nitrous oxide (N<sub>2</sub>O), ozone, perfluorocarbons, and hydrofluorocarbons. Indirect

contributors to greenhouse gases include compounds such as CO, NO<sub>x</sub>, and non-methane hydrocarbons. These photochemical gases can influence the rate of creation and destruction of gases that, in turn, may influence global climate change.

Over the last 100 years, the Earth's average surface temperature has risen by about 0.5° Celsius (°C) (1° Fahrenheit (°F)). This increase may be due to the addition of greenhouse gases from human activities. A rise in the Earth's average surface temperature could impact the climate, which in turn may lead to changes in the biosphere (e.g., changes in rainfall patterns and sea surface levels), which could have impacts on fauna, flora, and the human environment. In 2002, the United States had total net emissions of greenhouse gases of about  $6.2 \times 10^{12}$  kilograms (kg) ( $1.3 \times 10^{13}$  pounds (lb)), measured in terms of CO<sub>2</sub> equivalent, of which about 83 percent was CO<sub>2</sub> emissions (EPA 2004a).

Launch of an Atlas V with SRBs would result in the emission of greenhouse gases to the atmosphere. Primary exhaust emissions would consist of CO<sub>2</sub>, with trace emissions of nitrous oxide (N<sub>2</sub>O) emitted by the SRBs, NO<sub>x</sub> species, HCl, and water vapor. The exhaust would also contain carbon monoxide (CO), most of which would quickly react with oxygen in the atmosphere to form CO<sub>2</sub> under the high temperatures of the SRB exhaust. Emission estimates from a variety of expendable launch vehicles have been previously reported (USAF 1998, USAF 2000). The total emissions into upper atmospheric layers of all exhaust products from an Atlas V 551 was estimated to be about  $9.8 \times 10^4$  kg ( $2.2 \times 10^5$  lb), on the order of  $10^{-6}$  percent of the net emissions of greenhouse gases emitted by the United States in 2002. Therefore, launch of the Atlas V for the New Horizons mission would not be anticipated to substantially contribute to global climate change.

#### 4.1.2.13 Orbital and Reentry Debris

During the launch sequence of the Atlas V for the New Horizons mission (see Figure 2-8), the SRB casings, the first stage, and the PLF would be jettisoned and fall into the Atlantic Ocean in predetermined drop zones (see Section 4.1.2.11) well before reaching Earth orbit. Shortly after separating from the first stage, the Centaur second stage would be ignited, accelerating the Centaur and the attached third stage and spacecraft to low Earth parking orbit. After a brief coast period, the Centaur engine would be reignited, accelerating to Earth escape velocity. After propellant depletion, the Centaur would be separated from the third stage prior to ignition of the third stage motor. After propellant burnout, the third stage would be separated from the New Horizons spacecraft. The second and third stages would continue separately into interplanetary space. Therefore, a normal launch of the Atlas V for the New Horizons mission would not contribute to orbital or reentry debris.

#### 4.1.3 Environmental Impacts of Potential Accidents Not Involving Radioactive Material

As shown in Figure 4-1, an accident occurring during launch of the New Horizons mission is unlikely (62 out of 1,000). If an accident were to occur, then the highest conditional probability outcome (approximately 58 out of 62) is that such an accident would not involve release of PuO<sub>2</sub> from the RTG.

The potential environmental impacts associated with Atlas V accidents have been discussed in previous USAF environmental documentation (USAF 1998, USAF 2000), summarized here and augmented with new information where applicable. A variety of accidents could occur during preparations for and launch of an Atlas V. Only two types of nonradiological accidents would have potential off-site consequences: a liquid propellant spill occurring after the start of propellant loading operations, and a launch failure. The potential consequences of these accidents are presented below.

#### 4.1.3.1 Liquid Propellant Spills

A typical Atlas V uses about 284,089 kg (626,309 lb) of RP-1 and LO<sub>2</sub> for the first stage, and about 20,672 kg (45,573 lb) of liquid hydrogen (LH<sub>2</sub>) and LO<sub>2</sub>, with about 127 kg (280 lb) of hydrazine for the Centaur second stage (USAF 2000, ILS 2001). The New Horizons spacecraft would use about 80 kg (176 lb) of hydrazine for the primary mission (APL 2003d). The first stage and second stage fueling operations are performed in accordance with CCAFS propellant loading protocols. Standard procedures such as use of closed loop systems are practiced, which would minimize worker exposure and the potential for fuel releases.

Accidental leaks or spills of RP-1, LO<sub>2</sub>, LH<sub>2</sub>, and hydrazine could occur during propellant loading and unloading activities. USAF safety requirements specify that plans and procedures be in place to protect the workforce and the public during fueling operations (USAF 2004). Spill containment would be in place prior to any propellant transfer to capture any potential release. Hydrazine transfer would involve a relatively small amount of liquid through a relatively small transfer system, so any leakage would be held to an absolute minimum. The atmospheric dispersion of hydrazine from a liquid propellant accident has not been modeled, but it is expected that, because of the limited quantities involved, there would be no impact to the public in off-site areas.

Spill kits located in the work area would be used if a release is detected during RP-1 loading. Personnel would be present in the immediate area to handle any release. Workers would be required to wear personal protective equipment while loading RP-1 and hydrazine, and all unprotected workers would be removed from the area prior to loading. The operator would remotely close applicable valves to minimize any release and safe the system.

If a spill or release is detected during LO<sub>2</sub> and LH<sub>2</sub> loading at the launch pad, the operator would remotely close the applicable valves to minimize the amount of liquid released, and safe the system. Water deluge would be used only if heat is detected in the area of concern.

#### 4.1.3.2 Launch Failures

A launch vehicle accident either on or near the launch pad within a few seconds of lift-off presents the greatest potential for impact to human health, principally to workers. For the proposed New Horizons mission, the most significant potential health hazard during a launch accident would be from the HCl emitted from burning solid propellant from the SRBs. Range Safety at CCAFS uses models to predict launch hazards to the public and on-site personnel prior to every launch. These models calculate the risk of

injury resulting from toxic gases, debris, and blast overpressure from potential launch failures. Launches are postponed if the predicted collective public risk of injury exceeds acceptable limits, which are applied separately for the risk of injury from exposure to toxic gases, debris, and blast overpressure (USAF 2004). This approach takes into account the probability of a catastrophic failure, the resultant plume's toxic concentration, direction, and dwell time, and emergency preparedness procedures (USAF 2000).

Range Safety requirements mandate destruct systems on liquid propellant tanks and SRBs (see Section 2.1.6.5). In the event of destruct system activation, the propellant tanks and SRB casings would be ruptured, and the entire launch vehicle would be destroyed. A catastrophic launch failure would involve burning solid propellant and the ignition of liquid propellant (i.e., hydrazine, RP-1, LH<sub>2</sub>, and LO<sub>2</sub>). The potential short-term effects of an accident would include a localized fireball, falling debris from explosion of the vehicle, release of uncombusted propellants and propellant combustion products, and for on-pad or very low altitude explosions, death or damage to nearby biota and brush fires near the launch pad. Unburned pieces of solid propellant with high concentrations of ammonium perchlorate could fall on land or into nearby bodies of water. Perchlorate could leach into surrounding soil or water resulting in high concentrations in the immediate vicinity of the propellant fragment, and could result in adverse, localized impacts to the terrestrial or aquatic environment. Some mortality to biota in those areas could be expected until the solid propellant is fully dissolved. However, pieces of unburned solid propellant falling on land would be collected and disposed as hazardous waste. Similarly, large pieces falling in fresh water areas would be collected and disposed, minimizing the potential for perchlorate contamination (DOD 2003).

The USAF modeled postulated accidents at CCAFS involving combustion of Atlas V propellants (USAF 2000). Representative meteorological conditions were used in the analyses to model movement of the exhaust cloud. Release and combustion of both liquid and solid propellants were assumed to be involved. For the modeled accidents, the principal constituents resulting from burning propellant were CO, Al<sub>2</sub>O<sub>3</sub>, and HCl, but also included H<sub>2</sub>, H<sub>2</sub>O, and CO<sub>2</sub>. Although Al<sub>2</sub>O<sub>3</sub> would be deposited from the explosion cloud as it was carried downwind, little wet deposition of HCl would be expected unless rain falls through the cloud of combustion products. The estimated concentrations of combustion products resulting from these postulated accidents were found to be well within applicable Federal, State, and USAF standards. Based upon these analyses, emissions resulting from an accident during the New Horizons mission Atlas V launch would not be expected to exceed any of the applicable standards, and would not create adverse impacts to air quality in the region.

The USAF analysis did not take into account the potential combustion products from a third stage solid rocket motor. If ignited during a launch accident, the solid propellant in the third stage motor for the New Horizons mission would also emit CO, Al<sub>2</sub>O<sub>3</sub>, HCl, H<sub>2</sub>, H<sub>2</sub>O, and CO<sub>2</sub> as combustion products. However, the solid propellant in this motor would account for less than 1 percent of the total inventory of solid propellant aboard the Atlas V for the New Horizons mission. Therefore, these combustion products would not be expected to significantly factor into the previously estimated concentrations.

Parts of the exploded vehicle would fall back to Earth. Except for on-pad or near-pad accidents, most of the fragments would fall into the Atlantic Ocean, where the metal parts would eventually corrode. Toxic concentrations of metals would be unlikely because of slow corrosion rates and the large volume of ocean water available for dilution (USAF 1996).

Debris from launch failures has the potential to adversely affect managed fish species and their habitats in the vicinity of the launch site. Ammonium perchlorate in the solid propellant used in the Atlas V SRBs contains chemicals that, in high concentrations, have the potential to result in adverse impacts to the marine environment. The USAF has consulted with the National Marine Fisheries Service (NMFS) on essential fish habitat regarding launches of Atlas V vehicles from CCAFS (USAF 2000). Launch of the New Horizons mission from CCAFS would be covered under this consultation.

Residual RP-1 fuel is weakly soluble, would spread over the surface of the water, and should evaporate within a few hours, resulting in only a short-term impact to aquatic biota. Due to the relatively small quantities involved for the New Horizons mission, hydrazine either would be burned or be dispersed in the atmosphere without entering the ocean.

Beginning two hours before launch, a Brevard County Emergency Management Center representative would be present at a CCAFS launch console with direct audio and video communications links to the Center. The USAF also has a direct emergency phone line to the Florida State Emergency Response Center.

#### 4.1.4 Environmental Impacts of Potential Accidents Involving Radioactive Material

As shown in Figure 4-1, it is unlikely (62 out of 1,000) that an accident would occur during launch of the New Horizons mission. If an accident were to occur, the highest conditional probability outcome (approximately 58 out of 62) is that such an accident would not involve release of PuO<sub>2</sub> from the RTG. There remains, however, a lower conditional probability (approximately 4 out of 62, or an overall probability of 4 out of 1,000) that such an accident would involve release of some PuO<sub>2</sub> from the RTG to the environment. NASA and the U.S. Department of Energy (DOE) have assessed the potential environmental impacts of launch accidents involving release of PuO<sub>2</sub>. This section summarizes the results from DOE's *Nuclear Risk Assessment for the New Horizons Mission Environmental Impact Statement* (DOE 2005).

NASA and DOE and its contractors have conducted several safety assessments of launching and operating spacecraft using RTGs (e.g., the Galileo mission in 1989, the Ulysses mission in 1990, and the Cassini mission in 1997). In developing the nuclear risk assessment for this FEIS, NASA and DOE have drawn from an extensive experience base that involves:

- testing and analysis of the RTG and its components (e.g., fueled clads and aeroshell modules) (see Section 2.1.3.2) under simulated launch accident environments;

- evaluating the probability of launch-related accidents based on evaluations of system designs and launch histories, including extensive studies of the January 1997 Delta II accident at CCAFS; and
- estimating the outcomes of the response of the RTG and its components to the launch accident environments.

DOE's risk assessment for this FEIS (DOE 2005) was prepared in advance of the more detailed Final Safety Analysis Report (FSAR) being prepared in accordance with DOE Directives and to support the formal launch approval process required by Presidential Directive/National Security Council Memorandum 25 (PD/NSC-25), *Scientific or Technological Experiments with Possible Large-Scale Adverse Environmental Effects and Launch of Nuclear Systems into Space*. The FSAR for the New Horizons mission will be developed in a manner similar to those for past missions. Prior to the availability of the FSAR, information and results presented in the DOE risk assessment and summarized in this FEIS were developed based on consideration of risk assessments performed for previous missions (e.g., Cassini and the Mars Exploration Rovers), with additional supplemental analyses where considered appropriate. The resulting approach for DOE's risk assessment consists of a combination of scaling selected results for past missions on a per-curie inventory basis for specific launch accidents and accident environments, coupled with additional analyses as required for the New Horizons mission.

#### 4.1.4.1 Risk Assessment Methodology

The nuclear risk assessment for the New Horizons mission considers (1) potential accidents associated with the launch and their probabilities and resulting environments; (2) the response of the RTG to such accident environments in terms of varying amounts of radioactive material released (source terms) and the release probabilities; and (3) the radiological consequences and risks associated with such a release. The risk assessment was based on a typical radioactive material inventory of 132,500 curies (Ci) of plutonium (Pu)-238 (an alpha-emitter with a half life of 87.7 years) in the form of plutonium dioxide (PuO<sub>2</sub>). The activity includes minor contributions from other related plutonium and actinide radionuclides (see Table 2-3). The PuO<sub>2</sub> in the RTG to be used on the New Horizons spacecraft would consist of a mixture of fuel of differing ages, yet to be finalized. Based on the latest information, the inventory in the RTG is estimated to be in the range of 108,000 to 124,000 Ci. A reduction in the assumed inventory from 132,500 Ci would lead to an estimated proportional decrease in the results reported in DOE 2005 and summarized in this FEIS.

The basic steps in the risk assessment methodology are presented in Figure 4-2. The nuclear risk assessment for the New Horizons mission FEIS began with the identification of the initial launch vehicle system failures and the subsequent chain of accident events that could ultimately lead to the accident environments which could threaten the RTG. These launch vehicle system failures were based on Atlas V system reliabilities and estimated failure probabilities (NASA 2004).

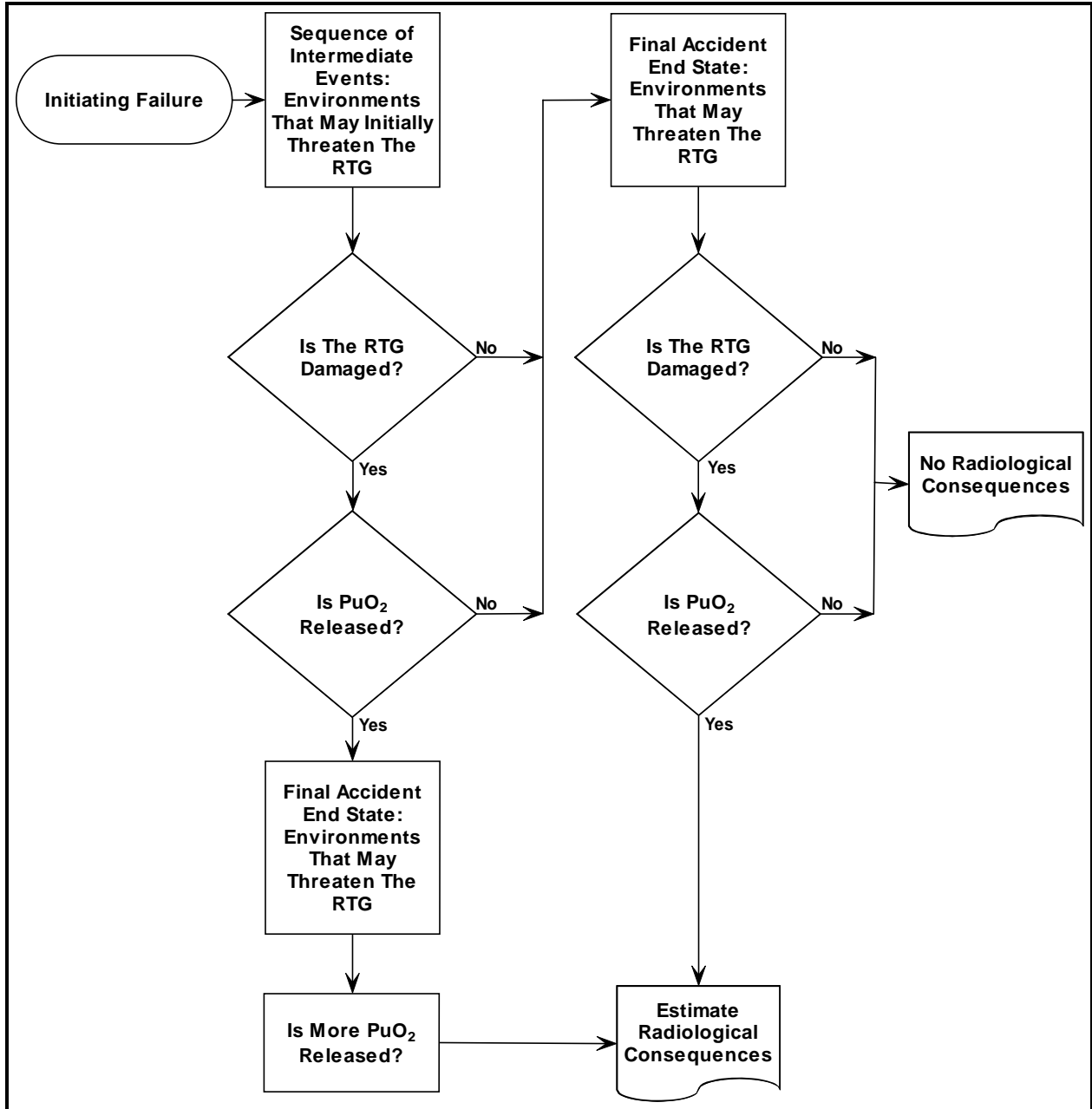

**FIGURE 4-2. THE RADIOLOGICAL RISK ASSESSMENT METHODOLOGY**

Some intermediate accident events, such as activation of the third stage solid rocket motor (SRM) breakup system (BUS), and final accident configurations, such as the RTG impacting the ground near burning solid propellant, have the potential to create accident environments that could damage the RTG and result in the release of PuO<sub>2</sub>. Based on

analyses performed for earlier missions that carried radioisotope devices<sup>1</sup>, DOE identified the specific accident environments that could potentially threaten the RTG. Four environments were identified for consideration for the New Horizons mission FEIS:

- (1) mechanical impact;
- (2) thermal energy;
- (3) fragment impacts; and
- (4) explosion overpressure.

The first three of these accident environments were identified as posing the greatest threat to the RTG. The specific environments of greatest concern are (1) ground impact of various intact configurations; (2) fire environments resulting from burning solid propellant; and (3) third stage motor fragments resulting from activation of the BUS.

DOE determined the response of the RTG and aeroshell modules to these accident environments and estimated the amount of radioactive material that could potentially be released. Results of DOE's RTG testing and analyses program were used to determine if a release of radioactive material from the RTG could potentially occur. The release fractions (the fraction of the PuO<sub>2</sub> that would be released to the environment) were determined by considering three primary accident environments: mechanical impact, burning solid propellant, and the fragments resulting from BUS activation. The source term results for RTG component mechanical impacts were determined by scaling relevant results based on analyses performed for the Cassini mission. The source terms for mechanical impacts associated with ground impact configurations and the solid propellant fire were based on the methodology used for the MER missions with specific adjustments made to account for three types of particle size distributions and the solid propellant amount and geometry specific to the Atlas V. The source terms for the BUS activation fragment environment were estimated with new analyses.

Consequences of postulated releases were estimated by scaling of selected results from previous missions and additional analyses to reflect conditions specific to the Atlas V and the New Horizons mission, including: population growth, plume configuration, launch complex location, meteorology, various types of particle size distribution, and solid propellant amount and geometry. Consequence values for population dose, maximum exposed individual dose, population health effects<sup>2</sup>, and land contamination were estimated at both mean and 99th percentile values.

While the results from safety analysis work performed in the past were used for this analysis, adjustments were made for population growth to 2006 for the local area (out to 100 km (62 mi) from the launch site) and globally. Where specific analyses were

---

<sup>1</sup> RTGs and radioisotope heater units (which contain about 2.7 grams (0.1 ounce) of PuO<sub>2</sub>, and generate 1 watt of heat for passive thermal control). Radioisotope heater units are not required for the New Horizons mission.

<sup>2</sup> Additional latent cancer fatalities due to a radioactive release (i.e., the number of cancer fatalities resulting from this release that are in addition to those cancer fatalities which the general population would normally experience from other causes).



performed (e.g., the solid propellant fire and BUS activation fragment environments), values of health effects per curie were calculated taking into account the location of SLC-41, the vertical plume configuration associated with potential accidents involving the Atlas V, meteorological conditions for the primary launch opportunity (January – February 2006), and particle size distribution.

The New Horizons mission was divided into six phases. Risk estimates were generated for each mission phase by combining the probabilities and consequences for each relevant accident. The risk estimates for all mission phases were then combined to produce a mission risk estimate.

#### 4.1.4.2 Launch Accidents and Accident Probabilities

For this risk assessment, the New Horizons mission was divided into six mission phases on the basis of mission elapsed time (the time (T) in seconds (s) relative to launch) reflecting principal launch events.

- Phase 0—Pre-Launch:  $60 \text{ hours} < T < 0 \text{ s}$ , during which the RTG is installed, final preparations for launch are made to the vehicle, the Flight Termination System (FTS) is armed, and the first stage main engine is ignited and undergoes "health check"<sup>3</sup>;
- Phase 1—Early Launch:  $0 \text{ s} < T < 40 \text{ s}$ , from when the SRBs are ignited until the vehicle clears land, after which most debris and intact vehicle configurations resulting from an accident would impact water;
- Phase 2—Late Launch:  $40 \text{ s} < T < 90 \text{ s}$ , when the vehicle reaches an altitude of 30 km (100,000 ft), above which reentry heating could occur;
- Phase 3—Pre-Orbit:  $90 \text{ s} < T < 622 \text{ s}$ , at the first Centaur engine thrust cutoff and the Command Destruct System (CDS) is disabled;
- Phase 4—Orbit:  $622 \text{ s} < T < 2,158 \text{ s}$ , from after reaching parking orbit to Earth escape; and,
- Phase 5—Escape:  $T > 2,158 \text{ s}$ , when Earth escape velocity is achieved.

Information on potential accidents and accident probabilities was developed by NASA based on inputs provided by the launch vehicle manufacturer, the third stage manufacturer, and the spacecraft provider. Accidents and their associated probabilities were developed in terms of initiating failures, defined as the first system-level indication of an anomaly that could lead to a launch abort (i.e., safe hold or termination of the launch countdown), catastrophic accident, or mission failure. An example of an initiating failure would be a trajectory control malfunction resulting in the launch vehicle deviating from its planned trajectory. An initiating failure is the beginning of a sequence of intermediate events that can lead to a range of possible end states, including

---

<sup>3</sup> The engine undergoes an automatic health check beginning at  $T-2.72 \text{ s}$ . Should a malfunction be detected before  $T=0$ , the engine would be shutdown and the launch would be aborted.

accident configurations involving the RTG and various launch vehicle stages<sup>4</sup> and the New Horizons spacecraft. For example, FTS activation following a trajectory control malfunction could lead to the RTG impacting the ground. Associated with the accident configuration end states are the four environments that could damage the RTG and result in the release of PuO<sub>2</sub>.

The end states that can result from the initiating failures are determined to a large extent by the FTS actions (see Section 2.1.6.5) that would or would not occur during the accident progression following the initiating failure. Important FTS considerations affecting the accident configurations are summarized below.

- The BUS would break up the Stage 3 SRM in order to minimize the possibility of coincident ground impact of the SRM and the SC. The BUS would be safed (automatically deactivated) at T+40 s, after which there would be no potential for land impact in the launch area.
- The Automatic Destruct System (ADS) would destruct the Stage 1 liquid-propellant tanks and the SRBs. The ADS would be safed prior to separation of Stages 1 and 2.
- The Centaur ADS (CADS) would destruct the Stage 1 tanks, the SRBs, the Stage 2 (Centaur) tanks, and the Stage 3 SRM (through the two small CSCs and the BUS). The CADS would be safed prior to separation of Stages 1 and 2.
- The CDS would be activated by the Mission Flight Control Officer (MFCO) and would destroy the launch vehicle in the same manner as a CADS activation. The MFCO would likely issue a CDS in case of a trajectory or attitude control malfunction where the launch vehicle deviation from the planned trajectory violates specific Range Safety criteria for continuation of a safe launch. Should the MFCO response time needed for CDS activation be insufficient, ground impact of the entire vehicle could occur. The CDS would be safed after the first Centaur engine burn.

The Pre-Launch (T < 0 s) initiating failures, their probabilities, and the resulting Pre-Launch accident end states are summarized in Table 4-1. The total probability of all Pre-Launch initiating failures is estimated to be  $1.9 \times 10^{-7}$  (or 1 in 5,300,000). These initiating failures include primarily Centaur tank failures and service valve failures. The Pre-Launch initiating failures generally involve, and are dominated by, conditions that can be mitigated by existing systems and procedures, leading to launch abort rather than accident conditions that threaten the RTG. The overall probability of ground impact configurations occurring that threaten the RTG is estimated to be  $2.9 \times 10^{-8}$  (or 1 in 34,000,000). These ground impact configurations include the Intact Stage 3/SC, the Destructed Stage 3/SC (occurring when only the two small CSCs below the SRM are activated), and the Intact RTG. The Intact Stage 3/SC configuration would result from initiating failures occurring prior to FTS activation. The FTS conditions leading to

---

<sup>4</sup> For brevity in the following discussion, the first, second, and third stages of the New Horizons Atlas V and spacecraft are sometimes referred to as Stages 1, 2, and 3, and SC respectively.

BUS activation would result in a breakup of the spacecraft, separating the RTG from the spacecraft; the RTG could then remain intact until ground impact or could break apart, freeing the aeroshell modules to impact the ground separately.

**TABLE 4-1. INITIATING FAILURES THAT CONTRIBUTE TO PRE-LAUNCH END STATES**

Initiating Failure	Initiating Failure Probability	Launch Abort	Ground Impact Configurations			
			Low-Speed Stage3/SC	Intact Stage3/SC	Destructed Stage3/SC	Intact RTG
Centaur LO <sub>2</sub> Tank Failure	9.0x10 <sup>-9</sup>	•	•	•	•	•
Centaur LH <sub>2</sub> Tank Failure	9.0x10 <sup>-9</sup>	•	•	•	•	•
LO <sub>2</sub> SRV <sup>(a)</sup> Failure	1.7x10 <sup>-7</sup>	•		•		
Inadvertent FTS Activation	3.5x10 <sup>-12</sup>				•	•
<b>Total Probability</b>	<b>1.9x10<sup>-7</sup></b>	<b>1.6x10<sup>-7</sup></b>	<b>1.1x10<sup>-14</sup></b>	<b>2.9x10<sup>-8</sup></b>	<b>3.5x10<sup>-15</sup></b>	<b>3.5x10<sup>-12</sup></b>

Sources: ASCA 2005, DOE 2005

(a) SRV = Self-Regulating Valve

Note: Differences in summations may be due to rounding.

The Post Launch (T ≥ 0 s) initiating failures during Phases 1 through 5 include:

- ground support equipment failures during liftoff;
- trajectory and attitude control malfunctions;
- propellant tank failures;
- catastrophic failures of the first or second stage main engines;
- structural failures;
- inadvertent FTS activation; and
- staging failures.

The specific Post Launch initiating failures, their probabilities, and the resulting Post Launch end states are summarized in Table 4-2 by mission phase. While the total probability of all Post Launch initiating failures is estimated to be 6.2x10<sup>-2</sup> (or 1 in 16), the vast majority of these, nearly 94 percent, would not result in accident conditions that lead to release of PuO<sub>2</sub> from the RTG. The Post Launch initiating failures can lead to one or more of the following end states.

- Phase 1 launch-area ground impact configurations, which include:
  - the complete Atlas V launch vehicle (called Full Stack Intact Impact (FSII));
  - the Intact Stage 2/Stage 3/SC with RTG attached;

**TABLE 4-2. INITIATING FAILURES THAT CONTRIBUTE TO POST LAUNCH END STATES**

Initiating Failure	Initiating Failure Probability	Accident End States by Mission Phase									
		Phase 1 Ground Impact Configurations						2	3	4	5
		FSII	Intact Stage2/ Stage3/SC	Intact Stage3/SC	Destructed Stage3/SC	Intact SC	Intact RTG	Water Impact	Suborbital Reentry	Orbital Reentry	Escape
Stage1 Main Engine Catastrophic Failure	9.4x10 <sup>-2</sup>	•	•		•		•	•	•		
GSE (a) Stage1 LO <sub>2</sub> Decoupler Failure	4.5x10 <sup>-5</sup>	•	•		•		•				
GSE Ground Wind Damper Failure	2.7x10 <sup>-4</sup>	•	•		•		•				
GSE Decoupler Failures	9.0x10 <sup>-5</sup>	•			•		•				
Attitude Control Malfunction	1.6x10 <sup>-2</sup>	•	•		•		•	•	•	•	•
Trajectory Control Malfunction	1.6x10 <sup>-2</sup>	•			•		•	•	•	•	•
SC Attach Fitting Structural Failure	1.0x10 <sup>-6</sup>	•			•	•	•	•	•	•	•
Stage3 Attach Fitting Structural Failure	1.0x10 <sup>-6</sup>			•			•	•	•	•	•
GSE Bolts Fail to Release	2.7x10 <sup>-5</sup>		•		•		•				
GSE Tank Events	7.2x10 <sup>-8</sup>		•		•		•		•	•	•
Inadvertent FTS Activation	1.3x10 <sup>-5</sup>				•		•	•	•	•	•
Stage1 Structural Failure	2.6x10 <sup>-7</sup>		•		•		•	•	•		
Stage1 Propellant Tank Failure	1.4x10 <sup>-5</sup>		•		•		•	•	•		
SRB Containment Failure	8.0x10 <sup>-3</sup>		•		•		•	•	•		
SRB Inadvertent Separation	9.6x10 <sup>-5</sup>		•		•		•	•	•		
PLF Structural Failure	2.3x10 <sup>-5</sup>		•		•		•	•	•		
Stage2 Structural Failure	4.1x10 <sup>-7</sup>			•	•		•	•	•	•	
Stage2 Propellant Tank Failure	8.6x10 <sup>-5</sup>			•	•		•	•	•	•	•
PLF Fails to Separate	1.2x10 <sup>-4</sup>							•	•		
Stages 1 and 2 Fail to Separate	2.3x10 <sup>-5</sup>							•	•		
Stages 1 and 2 Recontact	4.6x10 <sup>-7</sup>								•	•	•
Stage2 Main Engine Catastrophic Failure	4.5x10 <sup>-3</sup>							•	•	•	•
Stage2 Thrust Misdirected	4.3x10 <sup>-5</sup>								•	•	•
Stage2 Engine Fails to Restart	2.9x10 <sup>-4</sup>									•	•
Stages 2 and 3 Fail to Separate	5.6x10 <sup>-3</sup>									•	•
Stages 2 and 3 Recontact	1.6x10 <sup>-4</sup>									•	•
Stage3 SRM Fails to Ignite	2.2x10 <sup>-5</sup>										•
Stage3 SRM Case Rupture	3.5x10 <sup>-4</sup>										•
Stage3 Thrust Misdirected	2.0x10 <sup>-4</sup>									•	•
Stage3 Insufficient Thrust	2.0x10 <sup>-4</sup>										•
Stage3 and SC Fail to Separate	4.5x10 <sup>-4</sup>										•
SC Propellant Tank Failure	1.0x10 <sup>-6</sup>										•
<b>Total Probability</b>	<b>6.2x10<sup>-2</sup></b>	<b>2.5x10<sup>-6</sup></b>	<b>5.5x10<sup>-7</sup></b>	<b>2.0x10<sup>-8</sup></b>	<b>6.4x10<sup>-7</sup></b>	<b>9.1x10<sup>-9</sup></b>	<b>6.4x10<sup>-3</sup></b>	<b>7.8x10<sup>-3</sup></b>	<b>1.8x10<sup>-2</sup></b>	<b>3.8x10<sup>-3</sup></b>	<b>2.5x10<sup>-2</sup></b>

Sources: ASCA 2005, DOE 2005

(a) GSE = Ground Support Equipment  
 Note: Differences in summations may be due to rounding.

- the Intact Stage 3/SC with RTG attached;
- the Destructed Stage 3/SC with RTG attached;
- the Intact SC with RTG attached; and,
- the Intact RTG.
- Phases 2 through 5 end states, which include:
  - Water impact;
  - Sub-orbital reentry;
  - Orbital reentry; and,
  - Escape.

#### 4.1.4.3 RTG Response to Accident Environments

Accident environments associated with potential accidents include blast (explosion overpressure), fragments, thermal energy (from burning liquid and solid propellants), surface impact, and reentry environments. The nature and severity of the accident environments and the design features of the RTG and its components determine the response of the RTG and its components to the accident environments. These responses are then characterized in terms of the probability of release and the source terms.

Safety testing in combination with modeling of the response of the RTG and its components to accident environments allow estimates to be made of the probability of release of PuO<sub>2</sub> and the amount of the release for the range of accidents and environments that could potentially occur during the New Horizons mission. The aeroshell module, its graphite impact shells (GIS) and the iridium clads encapsulating the PuO<sub>2</sub> provide substantial protection against potential release of PuO<sub>2</sub> in accident environments. The primary accident environments of concern and the potential response of the RTG and its components to these environments are summarized below.

- Explosion Overpressure and Fragments: Explosions of the Stage 1 and Stage 2 liquid propellants and the resulting fragments are not expected to pose any significant threat to the RTG or its components. The RTG is expected to remain intact, and any release of PuO<sub>2</sub> from fueled clads would be small (ranging from a few milligrams to less than 0.5 grams (g) (0.02 oz), or about 6.2 Ci). Explosive burning of the Stage 3 SRM propellant on impact would result in an overpressure and fragment environment. These conditions, however, would cause less damage than the mechanical impact threat described below.
- Impact: Fracturing of the aeroshell module and its graphite components under explosion, fragment, and mechanical impact conditions would provide energy-absorbing protection to the iridium clad. The results of DOE's safety tests of the RTG and its components indicate that small releases of PuO<sub>2</sub> (ranging from a few milligrams to less than 0.5 g (0.02 oz), or about 6.2 Ci) are likely as a result of the impact of bare fueled clads, aeroshell modules, or the RTG on hard surfaces (e.g., concrete) at their respective terminal velocities. An end-on impact

of the RTG above the terminal fall velocity could result in higher releases (up to 16 g (0.6 oz), or about 197 Ci), such as could occur if the RTG is still attached to spacecraft hardware. Impact configurations such as FSII or Intact Stage 3/SC could result in higher releases (e.g., up to 150 g (5.3 oz), or about 1,845 Ci) if the third stage SRM impacts directly onto the RTG at velocities around 100 meters per second (m/s) (328 feet per second (ft/s)) or higher. The damage caused by the mechanical impact would be greater than that potentially caused by the overpressure and fragment environment associated with explosive burning of the SRM propellant upon ground impact.

- **Thermal Energy:** Exposure of released PuO<sub>2</sub> fuel to the high temperatures (ranging up to 2,827°C (5,120°F)) of burning solid propellant from the third stage SRM and the SRBs could lead to partial vaporization of the PuO<sub>2</sub>. Exposure of a bare (or breached) iridium clad, following graphite component damage in an accident, could also result in clad degradation either through chemical interactions or melting, resulting in partial vaporization of the PuO<sub>2</sub>. PuO<sub>2</sub> vapor releases from intact aeroshell modules are also possible in certain exposure conditions (e.g., modules lying beneath pieces of burning solid propellant larger than 113 kg (250 lb)). Under such conditions, temperatures inside the module could be high enough to degrade the iridium clads and vaporize some PuO<sub>2</sub>, which in turn could permeate through the somewhat porous graphite materials.
- **BUS Activation Fragment Environment:** The BUS (see Section 2.1.6.5) offers a significant risk reduction measure by minimizing the probability of coincident ground impact of the third stage SRM and the RTG. At the same time, the environment resulting from BUS activation could result in a smaller residual threat to the RTG. For this reason, the BUS would be safed after the Atlas V clears land and is over the Atlantic Ocean. The BUS activation environment would likely result in the breakup of the spacecraft, but the RTG is predicted to remain intact. The BUS activation environment would result in high-velocity (up to 3,200 m/s (10,500 ft/s)) aluminum fragments from the CSCs, aluminum fragments from the payload attach fitting (PAF), and solid propellant fragments from the breakup of the SRM. The latter fragments could also have attached titanium case material, or the titanium case material could detach during the breakup and become fragments themselves. The CSC fragment velocities would likely be attenuated by the PAF, the RTG converter materials and the aeroshell modules, resulting in a relatively low conditional probability (estimated to be 0.001, given BUS activation) of having a small release (up to 1.0 g (0.04 oz), or 12.3 Ci). Other, less energetic CSC fragments, could damage aeroshell modules without damaging iridium clads. While such fragments could result in a number of holes in the RTG case, the case is predicted to remain intact.

Solid propellant fragments from the SRM would have velocities in the range of 31 to 76 m/s (100 to 250 ft/s) with masses up to 120 kg (265 lb). Should any solid propellant fragments impact the RTG, side-on fragment impacts would likely not cause the RTG case or the aeroshell modules to fail. While aeroshell module damage is unlikely (with a conditional probability of graphite material damage of 0.05 given BUS activation), the motion of the aeroshell graphite material against

the iridium clads could result in small breaches in the iridium with subsequent small releases (in milligram quantities) of PuO<sub>2</sub> from affected clads (with a conditional probability of release of 0.003 given BUS activation). Damage of the insulators inside the GISs is also possible due to internal motion of the graphite materials against the clads. The leading clads in up to five aeroshell modules (ten clads total) could be affected in this manner. The released fuel, however, would be retained within the intact modules, unless such modules had suffered damage due to solid propellant fragments. While the above responses to the BUS activation environment would occur at some altitude above ground, subsequent impacts or environments (such as ground impact and exposure to burning solid propellant) could result in additional releases from any iridium clads already breached. Edge-on titanium fragments could cause graphite damage (with a conditional probability of 0.035 given BUS activation), and lead to a small release (1.0 g (0.04 oz), or 12.3 Ci, with a conditional probability of 0.007 given BUS activation).

Most launch accidents in Phases 0 and 1 would lead to one of several types of ground impact configurations (e.g., FSII, Intact Stage 2/Stage 3/SC, Intact Stage 3/SC, Intact SC, and Intact RTG). The highest probability configuration in Phase 0 is the Intact Stage 3/SC due to a Centaur explosion due to failure of a self-regulating vent valve prior to activating the FTS. The highest probability configuration in Phase 1 is the Intact RTG resulting from a CADS activation or a CDS with BUS activation. While the RTG is predicted to remain intact following BUS activation, it is possible that some aeroshell and iridium clad damage would occur at altitude due to the BUS fragment environment. In any case however, small releases are likely upon ground impact. For certain high mechanical impact environments, such as an FSII or an intact impact of a Stage 3/SC configuration with the SRM above the RTG, larger PuO<sub>2</sub> releases are possible. Subsequent exposure of RTG hardware and PuO<sub>2</sub> to burning solid propellant could result in increased releases through partial vaporization of the PuO<sub>2</sub>. The probability of exposure to burning solid propellant is higher in Phase 0 than Phase 1 because the SRBs are unpressurized in Phase 0, leading to less near-pad dispersal of burning solid propellant. Overall in Phases 0 and 1, given an accident, there is a relatively high conditional probability (0.78 and 0.25, respectively) of having small releases due to ground impacts (with some contribution due to the BUS activation fragment environment), and a relatively low conditional probability (0.28 and 0.015, respectively) for higher releases due to high threat mechanical impact environments and exposure to burning solid propellant.

No accidents have been identified in either Phase 2 or Phase 5 which could lead to a substantial release of PuO<sub>2</sub>. Accidents in Phase 2 would lead to water impacts of the RTG or aeroshell modules, which are designed to survive water impact. Accidents in Phase 5 would not lead to reentry of the RTG. In both Phases 3 and 4, accidents could lead to sub-orbital and orbital reentry heating and ground impact environments. Undamaged aeroshell modules are designed to survive reentry and subsequent impacts on water or soil at terminal velocity, but any impact on hard surfaces (e.g., rock or concrete) could result in small releases of PuO<sub>2</sub>.

#### 4.1.4.4 Accident Probabilities and Source Terms

In the nuclear risk assessment, DOE evaluated each of the identified end states and estimated the accident environments to which the RTG would likely be exposed. From that information, conditional probabilities that a release would occur and estimated source terms were developed based on the known response of an RTG to various accident environments.

As shown in Figure 4-1, the probability of a launch accident involving any release of PuO<sub>2</sub> is very small, approximately 4 in 1,000. The most severe accident environments would occur during launch area accidents that might expose the RTG to mechanical impacts, explosion overpressures and fragments, and fire environments from burning liquid and solid propellants.

A summary of the accident and source term probabilities by mission phase, along with mean and 99-th percentile source terms, is presented in Table 4-3. The 99-th percentile source term is the value predicted to be exceeded with a probability of 0.01 (1 in 100), given a release in an accident. In this context, the 99-th percentile value reflects the potential for larger releases at lower probabilities that could occur for accidents involving a release. Key results for the mean estimates are summarized below; the corresponding 99-th percentile estimates can be found in Table 4-3.

- Phase 0 (Pre-Launch): During the pre-launch period, prior to ignition of the SRBs, on-pad accidents could result in a release at an estimated total probability of  $2.2 \times 10^{-8}$  (or 1 in 45,000,000). The mean source term is estimated to be about 72 Ci. The mean source term in Phase 0 is higher than that in Phase 1 primarily due to the higher conditional probability of exposure to a solid propellant fire environment. However, none of the ground impact conditions that could occur in Phase 0 is very likely. Most problems that could arise during Phase 0 can be successfully mitigated by safety systems and procedures, leading to safe hold or termination of the launch countdown.
- Phase 1 (Early Launch): During Phase 1, after which land impacts in the launch area are unlikely (i.e., probabilities ranging from  $10^{-2}$  to  $10^{-4}$  as defined in Section 2.4.3.2), the total probability of release is estimated to be  $1.6 \times 10^{-3}$  (or 1 in 620) should an accident occur. The mean source term is estimated to be about 12 Ci.

Most initiating failures occurring in Phase 1 would lead to activation of the FTS. The elements of the FTS are highly redundant and quite reliable. As a result, the expected outcome of a Phase 1 accident is that the intact RTG would fall free to the ground, where it would be subject to mechanical damage and potential exposure to burning solid propellant. The probability for this impact configuration with a release is estimated to be  $1.6 \times 10^{-3}$  (or 1 in 620), with an estimated mean source term of less than 11 Ci (less than 0.01 percent of the PuO<sub>2</sub> inventory).



**TABLE 4-3. ACCIDENT PROBABILITIES AND SOURCE TERMS**

Mission Phase (Ground Impact Configuration)	Accident Probability	Conditional Probability of a Release <sup>(a)</sup>	Total Probability of a Release	Source Term, Ci	
				Mean	99-th Percentile <sup>(b)</sup>
0: Pre-Launch	2.9x10 <sup>-8</sup>	0.78	2.2x10 <sup>-8</sup>	71.9	217.0
(Stage 3/SC)	(2.8x10 <sup>-8</sup> )	(0.78)	(2.2x10 <sup>-8</sup> )	(71.9)	
(Intact RTG)	(3.5x10 <sup>-12</sup> )	(0.78)	(2.7x10 <sup>-12</sup> )	(29.0)	
1: Early Launch	6.4x10 <sup>-3</sup>	0.25	1.6x10 <sup>-3</sup>	11.8	98.2
(FSII)	(2.5x10 <sup>-6</sup> )	(0.29)	(7.1x10 <sup>-7</sup> )	(2610)	
(Stage2/Stage3/SC)	(5.5x10 <sup>-7</sup> )	(0.10)	(5.5x10 <sup>-8</sup> )	(767)	
(Stage3/SC)	(6.6x10 <sup>-7</sup> )	(0.13)	(8.7x10 <sup>-8</sup> )	(2520)	
(Intact SC)	(9.1x10 <sup>-9</sup> )	(0.24)	(2.2x10 <sup>-9</sup> )	(8.6)	
(Intact RTG)	(6.4x10 <sup>-3</sup> )	(0.25)	(1.6x10 <sup>-3</sup> )	(10.5)	
2: Late Launch	7.8x10 <sup>-3</sup>	—	—	—	—
3: Pre-Orbit	1.8x10 <sup>-2</sup>	0.04	7.9x10 <sup>-4</sup>	0.4	1.2
4: Orbit	3.8x10 <sup>-3</sup>	0.25	9.4x10 <sup>-4</sup>	0.9	5.3
5: Escape	2.5x10 <sup>-2</sup>	—	—	—	—
<b>Overall Mission:</b>	<b>6.2x10<sup>-2</sup></b>	<b>0.05</b>	<b>3.3x10<sup>-3</sup></b>	<b>6.0</b>	<b>48.6</b>

Source: DOE 2005

(a) The conditional probability of a release of PuO<sub>2</sub> given that an accident has occurred.

(b) Due to the nature of the methodology used in DOE's risk assessment (see Section 4.1.4.1), 99-th percentile source terms were not estimated for the individual ground impact configurations, listed in parentheses, which could occur during Phases 0 and 1.

Note: Differences in summations may be due to rounding.

A much less likely outcome of a Phase 1 accident involves failure of some or all of the FTS elements to perform properly. This could lead to ground impact of the RTG while still attached to the spacecraft and, perhaps, other launch vehicle stages. Since this would require multiple failures of safety systems, such ground impact configurations leading to a release are extremely unlikely (as defined in Section 2.4.3.2), with probabilities ranging from less than 10<sup>-6</sup> (less than 1 in 1 million) to nearly 10<sup>-10</sup> (nearly 1 in 10 billion). However, because the RTG could impact the ground in very close proximity to the SRM and the SRBs, the potential for damage to the RTG is much greater. In the impact configurations leading to the largest estimated releases, such as the FSII and the Intact Stage 3/SC, less than 2 percent of the inventory might be released, with estimated mean source terms of 2,610 Ci and 2,520 Ci, respectively. The overall probabilities of a release from these impact configurations are estimated to be 7.1x10<sup>-7</sup> (or 1 in 1,400,000) and 8.7x10<sup>-8</sup> (or 1 in 12,000,000), respectively.

- **Phase 2 (Late Launch):** All accidents that could occur in Phase 2 lead to impact of debris in the Atlantic Ocean with no release of PuO<sub>2</sub> from the RTG.
- **Phase 3 (Pre-Orbit):** Prior to attaining Earth parking orbit, accidents during Phase 3 could lead to prompt sub-orbital reentry within minutes of the accident

occurring. Breakup of the spacecraft during reentry could result in impacts of individual aeroshell modules along the vehicle flight path over the Atlantic Ocean and southern Africa. Should the aeroshell modules impact hard surfaces (e.g., rock), small releases of  $\text{PuO}_2$  are possible at ground level. The total probability of a release in Phase 3 is estimated to be  $7.9 \times 10^{-4}$  (or 1 in 1,300). The mean source term is estimated to be less than 0.5 Ci.

- Phase 4 (Orbit): Accidents which occur after attaining parking orbit could result in orbital decay reentries from minutes to years after the accident, affecting Earth surfaces between approximately  $28^\circ$  North Latitude and  $28^\circ$  South Latitude. Post-reentry impact releases would be similar to those in Phase 3, except more aeroshell modules could impact hard surfaces due to differences in the probability of impact on hard surfaces within these latitude bands. The total probability of a release in Phase 4 is estimated to be  $9.4 \times 10^{-4}$  (or 1 in 1,100). The mean source term is estimated to be less than 1 Ci.
- Phase 5 (Escape): No accidents which lead to Earth escape conditions are expected to result in a release of  $\text{PuO}_2$ . The potential exists for a long-term (hundreds to thousands of years) inadvertent reentry should the spacecraft be left in an orbit around the Sun which crosses the Earth's orbit. Such a situation could occur if the Centaur engine would fail to restart after achieving Earth orbit, in which case the third stage and spacecraft would be separated from the Centaur, and the SRM would be fired. If the Centaur engine restarts successfully but the third stage SRM would fail to ignite, the spacecraft would still be separated. In either case the New Horizons spacecraft would have gained enough velocity to escape the Earth's gravitational field, but without sufficient energy to reach Pluto. The potential for either situation has been evaluated for a range of Earth-escape conditions (APL 2003c), and the probability of a long-term inadvertent reentry is estimated to be less than  $1 \times 10^{-7}$  (less than 1 in 10 million). This probability takes into account the use of spacecraft thrusters following escape to sufficiently alter the spacecraft's orbit and thereby minimize the potential for remaining in a long-term Earth crossing orbit.

The specific probability values presented in this DEIS are estimates and will likely differ from those presented in the more detailed FSAR being prepared by DOE for the New Horizons mission. Some probabilities will likely increase while others may decrease. However, NASA expects the overall probability of an accidental release of radioactive material will not vary substantially from the values presented in this DEIS.

#### 4.1.4.5 Radiological Consequences

The radiological consequences of a given accident that results in a radiological release have been calculated in terms of maximum individual dose, collective dose, health effects, and land area contaminated at or above specified levels. The radiological consequences have been determined from atmospheric transport and dispersion simulations incorporating both launch-site specific and worldwide meteorological and population data. Biological effects models, based on methods prescribed by the National Council on Radiation Protection and Measurements (NCRP) and the

International Commission on Radiological Protection (ICRP), were applied to predict the number of health effects following a New Horizons launch accident that results in a release of PuO<sub>2</sub>. Additional information on the behavior of plutonium in the environment (environmental transport and health impact mechanisms) can be found in Appendix B.

The maximum individual dose is the maximum dose delivered to a single individual for each accident case simulation. Collective dose is the sum of the radiation dose received by all individuals exposed to radiation from a given release in units of person-rem. Health effects represent statistically estimated incremental cancer fatalities induced by exposure to a release of radioactive material, and are determined by using ICRP-60 estimators<sup>5</sup> of  $5 \times 10^{-4}$  fatalities per person-rem for the general population and  $4 \times 10^{-4}$  fatalities per person-rem for workers (ICRP 1990). The health effects estimators are based on a linear, non-threshold model relating health effects and effective dose. This means that health effects occur as the dose increases from zero, rather than assuming a model in which health effects occur only at or above a threshold dose.

Table 4-4 presents a summary the DOE's risk assessment of radiological consequences for each of the mission phases. These consequence estimates represent the best available information at this time. Since the DOE's risk assessment for this FEIS was prepared in advance of the more detailed analysis being prepared for the FSAR, the information and results were developed based on consideration of risk assessments performed for past missions (e.g., Cassini and MER), and additional supplemental analyses where considered appropriate. The resulting approach for the risk assessment consists of a combination of scaling the results for past missions on a per curie inventory basis for specific accidents and accident environments, coupled with additional analyses required to make the risk assessment specific to the New Horizons mission.

The radiological consequences were estimated by mission phase in terms of both the mean and 99-th percentile values. The 99-th percentile radiological consequence is the value predicted to be exceeded 1 percent of the time for an accident with a release. In this context, the 99-th percentile value reflects the potential for higher radiological consequences to the exposed population at lower probabilities. For most accidents, the 99-th percentile consequences are a factor of 5 to 15 times the mean estimates reported in this EIS, but at probabilities a factor of 100 lower.

The radiological consequences summarized in Table 4-4 are generally proportional to the source terms listed in Table 4-3, except that the scaling factors vary with the type and nature of the release. Key factors include the particle size distribution of the release, release height, and energy of the release. Key results for the mean estimates are summarized below; the corresponding 99-th percentile estimates can be found in Table 4-4.

---

<sup>5</sup> Another estimator addressing total health impacts (i.e., total detriment, as defined by ICRP-60) includes fatal cancers, non-fatal cancers, and hereditary effects. Total detriment is determined using estimators of  $7.3 \times 10^{-4}$  health impacts per person-rem for the general population and  $5.6 \times 10^{-4}$  health impacts per person-rem for workers (ICRP 1990).

**TABLE 4-4. ESTIMATED RADIOLOGICAL CONSEQUENCES**

Mission Phase (Ground Impact Configuration)	Total Probability of Release	Maximum Individual Dose, rem		Collective Dose, person-rem		Health Effects <sup>(a)</sup>		Land Contamination <sup>(b)</sup> km <sup>2</sup>	
		Mean	99-th Percentile <sup>(d)</sup>	Mean	99-th Percentile <sup>(d)</sup>	Mean	99-th Percentile <sup>(d)</sup>	Mean	99-th Percentile <sup>(d)</sup>
0: Pre-Launch	2.2x10 <sup>-8</sup>	3.1	47.4	9,600	53,700	4.8	26.5	12.2	136.0
(Stage 3/SC)	(2.2x10 <sup>-8</sup> )	(3.1)		(9,600)		(4.8)		(12.2)	
(Intact RTG)	(2.7x10 <sup>-12</sup> )	(0.7)		(2,320)		(1.2)		(3.2)	
1: Early Launch	1.6x10 <sup>-3</sup>	0.3	7.1	718	10,500	0.4	5.2	1.8	10.7
(FSII)	(7.1x10 <sup>-7</sup> )	(54.3)		(206,000)		(102.0)		(297.0)	
(Stage2/Stage3/SC)	(5.5x10 <sup>-8</sup> )	(13.7)		(58,200)		(28.9)		(80.0)	
(Stage3/SC)	(8.7x10 <sup>-8</sup> )	(46.3)		(183,000)		(90.6)		(269.0)	
(Intact SC)	(2.2x10 <sup>-9</sup> )	(0.2)		(427)		(0.2)		(1.2)	
(Intact RTG)	(1.6x10 <sup>-3</sup> )	(0.3)		(612)		(0.3)		(1.6)	
2: Late Launch	—	—	—	—	—	—	—	—	—
3: Pre-Orbit	7.9x10 <sup>-4</sup>	0.1	0.8	3	18	0.002	0.009	0.009	0.05
4: Orbit	9.4x10 <sup>-4</sup>	0.4	2.5	34	422	0.02	0.2	0.02	0.1
5: Escape	—	—	—	—	—	—	—	—	—
<b>Overall Mission <sup>(c)</sup></b>	<b>3.3x10<sup>-3</sup></b>	<b>0.3</b>	<b>4.3</b>	<b>352</b>	<b>5,120</b>	<b>0.2</b>	<b>2.5</b>	<b>0.9</b>	<b>5.1</b>

Source: DOE 2005

- (a) Based on ICRP-60 health effects estimators of 5x10<sup>-4</sup> health effects per person-rem for the general population and 4x10<sup>-4</sup> health effects per person-rem for workers.
- (b) Land area contaminated above 0.2 μCi/m<sup>2</sup>; 1 km<sup>2</sup> = 0.386 mi<sup>2</sup>.
- (c) Overall mission values weighted by total probability of release for each mission phase.
- (d) 99-th percentile consequences were not estimated for the individual ground impact configurations which could occur during Phases 0 and 1.

Note: Differences in summations may be due to rounding.

- Phase 0 (Pre-Launch): The initiating failures that result in Phase 0 accident configurations have very low probabilities of occurrence. The overall probability of a release is  $2.2 \times 10^{-8}$  (or 1 in 45,000,000) during Phase 0. Most problems that arise during Phase 0 can be successfully mitigated by safety systems and procedures leading to safe hold or termination of the launch countdown.

If an accident were to occur during Phase 0, however, there is a potential for measurable releases and off-site contamination. For Phase 0 accidents, there are no mechanisms which would ensure that the RTG becomes separated from the spacecraft and avoid large pieces of burning solid propellant. The mean maximum dose to an individual is estimated to be approximately 3 rem, about a factor of 9 higher than an individual might receive annually from natural background radiation<sup>6</sup>. This level is, however, significantly lower than that needed to result in short-term biological effects. It would increase the chance of a health effect for the exposed person by about 0.75 percent (from about 20–25 percent due to normal cancer incidence to about 20.15–25.15 percent with normal incidence plus radiation exposure). The mean collective dose is estimated to be 9,600 person-rem to the potentially exposed population.

For Phase 0 accidents with a release (probability of 1 in 45,000,000), the mean area contaminated above 0.2 microcuries per square meter ( $\mu\text{Ci}/\text{m}^2$ ) (see Section 4.1.4.7) is estimated to be about 12 square kilometers ( $\text{km}^2$ ) (about 4.6 square miles ( $\text{mi}^2$ )). Detectable levels below  $0.2 \mu\text{Ci}/\text{m}^2$  would be expected over an even larger area. Assuming no mitigation actions, such as sheltering and exclusion of people from contaminated land areas, the potentially exposed population is predicted to inhale enough material to result in 4.8 mean health effects among the potentially exposed population.

- Phase 1 (Early Launch): Most initiating failures occurring in Phase 1 would lead to activation of the FTS. The elements of the FTS are highly redundant and very reliable<sup>7</sup>. As a result, the expected outcome of a Phase 1 accident is that the intact RTG or its components could fall free to the ground, where it would be subject to mechanical damage and potential exposure to burning solid propellant. The probability for this impact configuration with a release is  $1.6 \times 10^{-3}$  (or 1 in 620). A release could result in the spread of fine particles of  $\text{PuO}_2$  over the area. The mean maximum individual dose is estimated to be 0.3 rem, equivalent to about 80 percent of the dose an individual might receive annually from natural background radiation. It would increase the exposed person's chance of a health effect by about 0.075 percent. The mean collective dose is estimated to be 718 person-rem to the potentially exposed population.

The risk assessment indicates that less than  $2 \text{ km}^2$  (less than  $0.8 \text{ mi}^2$ ) might be contaminated above  $0.2 \mu\text{Ci}/\text{m}^2$ . Assuming no mitigation action, such as

---

<sup>6</sup> An average of about 0.36 rem per year for an individual in the United States, including both natural sources and other sources such as medical X-rays; see Section 3.2.5 for further information.

<sup>7</sup> Range Safety specifies that for any launch vehicle FTS, the reliability goal shall be a minimum of 0.999 at the 95 percent confidence level (USAF 2004).

sheltering, the potentially exposed population is predicted to inhale enough material to result in 0.4 mean health effects among the potentially exposed population.

A much less likely outcome of a Phase 1 accident involves failure of some or all of the FTS elements to perform properly. This could lead to ground impact of the RTG while still attached to the spacecraft and, perhaps, other launch vehicle stages. Since this would require multiple failures of safety systems, such ground impact configurations leading to a release are extremely unlikely, ranging from 1 in 1.4 million to 1 in 18 million or less. However, because the RTG could impact the ground in very close proximity to the SRM and the SRBs, the potential for damage to the RTG is much greater. In the impact configurations leading to the largest estimated releases, such as the FSII and the Intact Stage 3/SC, less than 2 percent of the inventory might be released, potentially resulting in exposures as high as about 54 rem to the maximum exposed individual, and an estimate of nearly 300 km<sup>2</sup> (about 115 mi<sup>2</sup>) might be contaminated above 0.2 μCi/m<sup>2</sup>. Detectable levels below 0.2 μCi/m<sup>2</sup> would be expected over an even larger area. Assuming no mitigation action, such as sheltering, the potentially exposed population is predicted to inhale enough material to result in an estimated 102 mean health effects among the potentially exposed population.

- Phase 2 (Late Launch): No radiological consequences would be expected from an accident that could occur during Phase 2 since any accident during this mission phase would lead to impact of debris in the Atlantic Ocean with no release of PuO<sub>2</sub> from the RTG.
- Phases 3 (Pre-Orbit): The total probability of a release in Phase 3 is estimated to be  $7.9 \times 10^{-4}$  (or 1 in 1,300). Mean consequences are estimated to be 0.1 rem for maximum individual dose, 3 person-rem for collective dose, and 0.002 health effects among the potentially exposed population.
- Phase 4 (Orbit): The total probability of a release in Phase 4 is estimated to be  $9.4 \times 10^{-4}$  (or 1 in 1,100). Mean consequences are estimated to be 0.4 rem for maximum individual dose, 34 person-rem for collective dose, and 0.02 health effects among the potentially exposed population.
- Phase 5 (Escape): No radiological consequences would be expected from an accident that could occur during Phase 5 since any accident during this mission phase would still lead to the spacecraft escaping the Earth's gravity field.

#### 4.1.4.6 Discussion of the Results

##### *Maximum Individual Doses*

The maximum individual dose is the maximum dose delivered to a single individual for each accident based on the mean value results. During Phase 1, the predicted mean radiation dose to the maximally exposed individual ranges from very small, about 0.3 rem for the most probable result of a launch area accident, up to about 54 rem for an extremely unlikely FSII. No short-term radiological effects would be expected from any

of these exposures. Each exposure would increase the statistical likelihood of a health effect. It should be noted that there are very large variations and uncertainties in the prediction of close-in doses due to the large variations and uncertainties in the locations of individuals, meteorological conditions, periods of exposure, and dispersion modeling.

#### *Population Exposures*

Impacts to off-site, downwind populations that might be exposed to releases following an accident are estimated by first calculating the collective dose to that population. This is simply the sum of the radiation dose received by all individuals exposed to radiation from a given release. These collective doses are assumed to result in the potential for health effects among the potentially exposed population following an accident. The health effects induced by releases are calculated using the methods described above in Section 4.1.4.5. The consequences discussed below have been estimated considering impacts on both the local population and the global population. Because of a variety of factors, principally involving meteorological conditions at the time of launch and the amount and particle size distribution of any PuO<sub>2</sub> released, not all persons in the affected regions would be exposed to a release.

Prior to launch, most problems that could potentially lead to an accident would be mitigated by safety systems and procedures that would lead to safe hold or termination of the launch countdown. After launch, most significant problems would lead to activation of the FTS, which would result in the destruction of all of the vehicle stages. This would lead to the RTG falling to the ground, where it could be subject to mechanical damage and potential exposure to burning solid propellant. The predicted release for this end state is estimated to be less than 0.01 percent of the inventory of the RTG. The probability for this scenario with a release is  $1.6 \times 10^{-3}$  (or 1 in 620). Assuming no interdiction, such as sheltering and exclusion of people from contaminated land areas, the potentially exposed population is predicted to inhale enough material to result in an additional 0.4 health effects among the exposed population over the long term.

For extremely unlikely launch area accidents, ranging in probability from 1 in 1.4 million to 1 in 18 million or less, slightly higher releases, approximately 2 percent of the RTG's inventory, might be expected with potentially higher consequences. Detectable levels below  $0.2 \mu\text{Ci}/\text{m}^2$  would be expected over a large area. Assuming no mitigation actions such as sheltering, the potentially exposed population for these extremely unlikely accidents with a release is predicted to inhale enough material to result in an estimated 90 to 100 health effects.

In the event of a launch area accident, it is unlikely that any given racial, ethnic, or socioeconomic group of the population would bear a disproportionate share of the consequences.

#### 4.1.4.7 Impacts of Radiological Releases on the Environment

The environmental impacts of the postulated accidents include the potential for PuO<sub>2</sub> to be released to the environment, resulting in land and surface water contamination. The health and environmental impacts associated with plutonium-238 in the environment

were addressed extensively in the EISs for previous NASA missions that used RTGs, including the Galileo, Ulysses, and Cassini missions (NASA 1989, NASA 1990, NASA 1995a, NASA 1997). The Ulysses EIS, for example, also identified the potential for launch area accidents contaminating comparable land areas. That EIS contained extensive evaluations of the potential impacts of PuO<sub>2</sub> releases on natural vegetation, wetlands, agricultural land, urban areas, inland water, the ocean, and other global areas. Based on these previous analyses, the potential impacts of plutonium releases from the launch area accidents on the environment are discussed in Appendix B and summarized here.

The affected environment, described in Section 3 of this EIS, includes the regional area near CCAFS and the global area. Launch area accidents (Phases 0 and 1) would initially release material into the regional area, defined in the EIS to be within 100 km (62 mi) of the launch pad. Since some of the accidents result in the release of very fine particles (less than a micron in diameter), a portion of such releases could be transported beyond 100 km (62 mi) and become well mixed in the troposphere, and have been assumed to potentially affect persons living within a latitude band from approximately 23° North to 30° North. Releases during Phase 3 could involve reentering aeroshell modules that could impact the ground in southern Africa. Releases during Phase 4 could impact anywhere between 28° North and 28° South latitude.

Potential environmental contamination was evaluated in terms of areas exceeding various screening levels (0.1 and 0.2 μCi/m<sup>2</sup>, and dose-rate related criteria (15, 25, and 100 millirem per year (mrem/yr))) considered by the U.S. Environmental Protection Agency (EPA), the Nuclear Regulatory Commission, and DOE in evaluating the need for land cleanup following radioactive contamination.

The risk assessment for this EIS uses the 0.2 μCi/m<sup>2</sup> screening level (a screening level used in prior NASA environmental documentation (e.g., NASA 1989, NASA 1997, NASA 2003)) as an indicator of the extent of land area contaminated due to a release of PuO<sub>2</sub> from a potential launch accident. The results are summarized in Table 4-4. The area of land contaminated above the EPA lifetime-risk criterion, associated with an average annual dose rate criterion of 15 mrem/yr, could range from 3 to 6 times higher than the land area contaminated above the 0.2 μCi/m<sup>2</sup> level in the first year following the release. This is due in part to the contribution of resuspension to dose. The 0.2 μCi/m<sup>2</sup> screening level is used because following the first year after a release, the areas contaminated above the 15 mrem/yr criterion would be expected to decrease to values comparable to those associated with the 0.2 μCi/m<sup>2</sup> level.

DOE's risk assessment indicates that for the most likely type of launch area accidents, the intentional destruction of all the vehicle stages freeing the RTG to fall back to the ground, would result in about 1.6 km<sup>2</sup> (about 0.6 mi<sup>2</sup>) being contaminated above 0.2 μCi/m<sup>2</sup>. The risk assessment also indicates that in at least one extremely unlikely ground impact configuration, the FSII with a total probability of release of 7.1x10<sup>-7</sup> (or 1 in 1.4 million), that nearly 300 km<sup>2</sup> (about 115 mi<sup>2</sup>) might be contaminated above 0.2 μCi/m<sup>2</sup>. Detectable levels below 0.2 μCi/m<sup>2</sup> would be expected over an even larger area.



Land areas contaminated at levels above 0.2  $\mu\text{Ci}/\text{m}^2$  indicate areas potentially needing further action, such as monitoring or cleanup. Costs associated with these efforts, as well as continued monitoring activities, could vary widely depending upon the characteristics of the contaminated area. Potential cost estimating factors for decontamination of various land types are summarized in Table 4-5. These cost factors address a wide variety of possible actions, including land acquisition, off-site waste disposal, site restoration, and final surveys of remediated sites.

**TABLE 4-5. POTENTIAL LAND DECONTAMINATION COST FACTORS**

Land Type	Cost Factor in 2006 Dollars	
	Cost per $\text{km}^2$	Cost per $\text{mi}^2$
Farmlands	\$95 million	\$246 million
Rangeland	\$93 million	\$241 million
Forests	\$170 million	\$440 million
Mixed-Use Urban Areas	\$520 million	\$1.3 billion

Source: Adapted from Chanin et al. 1996

The Price-Anderson Act, as amended (42 U.S.C. 2210), governs liability and compensation in the event of a nuclear incident arising out of the activities of the DOE. The Price-Anderson Act is incorporated into the Atomic Energy Act, as amended (42 U.S.C. 2011 et seq.). A "nuclear incident" is defined under the Atomic Energy Act "as any occurrence, including an extraordinary nuclear occurrence, within the United States causing, within or outside the United States, bodily injury, sickness, disease, or death, or loss of or damage to property, or loss of use of property, arising out of or resulting from the radioactive, toxic, explosive, other hazardous properties of source, special nuclear or byproduct material..." (42 U.S.C. 2014 (q)). In the case of the New Horizons mission, DOE retains title to the RTG. The RTG would, therefore, be subject to Price-Anderson Act provisions. In the unlikely event that an accident were to occur resulting in release of  $\text{PuO}_2$ , affected property owners would be eligible for reimbursement for loss of property due to contamination.

In addition to the potential direct costs of radiological surveys, monitoring, and potential cleanup following an accident, there are potential secondary societal costs associated with the decontamination and mitigation activities with the extremely unlikely, potentially higher consequence, launch area accidents. Those costs could include, but may not be limited to:

- temporary or longer term relocation of residents;
- temporary or longer term loss of employment;
- destruction or quarantine of agricultural products, including citrus crops;
- land use restrictions (which could affect real estate values, tourism and recreational activities);

- restriction or bans on commercial fishing; and,
- public health effects and medical care.

4.1.4.8 Mission Risks

A summary of the mission risks is presented in Table 4-6. For the purpose of this EIS, risk is defined as the expectation of health effects in a statistical sense (i.e., the product of total probability times the mean health effects resulting from a release, and then summed over all conditions leading to a release). The risk of health effects in the potentially exposed populations is determined for each mission phase and the overall mission. Since the health effects resulting from a release equals the sum of the probability of a health effect for each individual in the exposed population, risk can also be interpreted as the total probability of one health effect given the mission. The overall radiological risk for the New Horizons mission is estimated to be  $5.8 \times 10^{-4}$ . Thus, the total probability of one health effect for the Proposed Action is about 1 in 1,700.

**TABLE 4-6. SUMMARY OF HEALTH EFFECT MISSION RISKS**

Mission Phase	Accident Probability	Conditional Probability of a Release	Total Probability of a Release	Mean Health Effects	Mission Risks
0: Pre-Launch	$2.9 \times 10^{-8}$	0.78	$2.2 \times 10^{-8}$	4.8	$1.1 \times 10^{-7}$
1: Early Launch	$6.4 \times 10^{-3}$	0.25	$1.6 \times 10^{-3}$	0.4	$5.6 \times 10^{-4}$
2: Late Launch	$7.9 \times 10^{-3}$	—	—	—	—
3: Pre-Orbit	$1.8 \times 10^{-2}$	0.04	$7.9 \times 10^{-4}$	0.002	$1.4 \times 10^{-6}$
4: Orbit	$3.8 \times 10^{-3}$	0.25	$9.4 \times 10^{-4}$	0.02	$1.6 \times 10^{-5}$
5: Escape	$2.5 \times 10^{-2}$	—	—	—	—
<b>Overall Mission</b>	<b><math>6.2 \times 10^{-2}</math></b>	<b>0.05</b>	<b><math>3.3 \times 10^{-3}</math></b>	<b>0.2</b>	<b><math>5.8 \times 10^{-4}</math></b>

Source: DOE 2005

Note: Differences in summations may be due to rounding.

The risk contribution of Phase 1 accidents,  $5.6 \times 10^{-4}$  (or a probability of about 1 in 1,800 that a health effect will occur), represents 97 percent of the radiological risk for the New Horizons mission. The primary contributors to the Phase 1 risk are accidents leading to intact ground impact of the RTG in the vicinity of burning solid propellant from the SRBs and the third stage SRM. Phases 3 and 4 contribute most of the remainder of the overall mission risk, due primarily to releases associated with aeroshell modules impacting hard surfaces following sub-orbital or orbital reentry.

The contributions of risk to the local area (within 100 km (62 mi) of SLC-41) and the global area are summarized in Table 4-7. The launch area risk is about 33 percent of the overall mission risk, while the risk to global areas is about 67 percent. The launch area risks are due entirely from accidents during Phases 0 and 1. The global risks are due to accidents in all mission phases.

**TABLE 4-7. HEALTH EFFECT MISSION RISK CONTRIBUTIONS BY AFFECTED REGION**

Mission Phase	Mission Risks		
	Launch Area <sup>(a)</sup>	Global <sup>(b)</sup>	Total
0: Pre-Launch	$3.6 \times 10^{-8}$	$7.0 \times 10^{-8}$	$1.1 \times 10^{-7}$
1: Early Launch	$1.9 \times 10^{-4}$	$3.7 \times 10^{-4}$	$5.6 \times 10^{-4}$
2: Late Launch	—	—	—
3: Pre-Orbit	—	$1.4 \times 10^{-6}$	$1.4 \times 10^{-6}$
4: Orbit	—	$1.6 \times 10^{-5}$	$1.6 \times 10^{-5}$
5: Escape	—	—	—
<b>Overall Mission</b>	<b><math>1.9 \times 10^{-4}</math></b>	<b><math>3.9 \times 10^{-4}</math></b>	<b><math>5.8 \times 10^{-4}</math></b>

Source: DOE 2005

(a) Phases 0 and 1: within 100 km (62 mi) of the launch pad.

(b) Phases 0, 1 and 2: within approximately 23° North and 30° North Latitude; Phase 3: southern Africa; Phase 4: land impacts between 28° North and 28° South Latitude.

Note: Differences in summations may be due to rounding.

Another descriptor used in characterizing risk is the average individual risk, presented in Table 4-8. The average individual risk, defined in this EIS as the risk divided by the number of persons potentially exposed, is estimated to be  $5.1 \times 10^{-10}$  (or a probability of about 1 in 2 billion that a health effect will occur for that individual) in the launch area and  $4.3 \times 10^{-13}$  (or a probability of about 1 in 2.3 trillion that a health effect will occur for that individual) globally. In estimating the average individual risks, the population at risk in each mission phase is taken to be those individuals receiving most of the collective dose, rather than the entire population in any given area of interest. All individuals within the exposed population (including the maximally exposed individual) face less than a one-in-a-million chance of a health effect due to the radiological consequences posed by the New Horizons mission.

These individual risk estimates are small compared to other risks (see, for example, Table 2-5). This data indicates that in 2000 the average individual risk of accidental death in the United States was about 1 in 3,000 per year, while the average individual risk of death due to any disease, including cancer, was about 1 in 130.

#### 4.1.4.9 Uncertainty

An uncertainty analysis to estimate uncertainties in probabilities, source terms, radiological consequences, and mission risks has not been performed as part of this report. Such an analysis will be performed in the Final Safety Analysis Report. Based on experience with uncertainty analyses in the preliminary risk assessment of previous missions (e.g., for the Cassini and MER missions), the uncertainty in the estimated mission risk for the New Horizons mission can be made. The best estimate of the New Horizons mission risk of  $5.8 \times 10^{-4}$  (or a probability of about 1 in 1,700 that a health effect will occur) can be treated as the median of the uncertainty probability distribution (i.e., it

is equally probable that the mission risk could be higher or lower than this value). The mission risks at the 5 and 95 percent confidence levels are then estimated to be  $2.3 \times 10^{-5}$  (or a probability of about 1 in 44,000 that a health effect will occur) and  $1.4 \times 10^{-2}$  (or a probability of about 1 in 71 that a health effect will occur), respectively.

**TABLE 4-8. AVERAGE INDIVIDUAL RISK BY AFFECTED REGION**

Mission Phase	Launch Area <sup>(a)</sup>			Global <sup>(b)</sup>		
	Mission Risk	Population at Risk <sup>(c)</sup>	Average Individual Risk <sup>(d)</sup>	Mission Risk	Population at Risk <sup>(c)</sup>	Average Individual Risk <sup>(d)</sup>
0: Pre-Launch	$3.6 \times 10^{-8}$	$3.7 \times 10^5$	$9.6 \times 10^{-14}$	$7.0 \times 10^{-8}$	$9.4 \times 10^8$	$7.5 \times 10^{-17}$
1: Early Launch	$1.9 \times 10^{-4}$	$3.7 \times 10^5$	$5.1 \times 10^{-10}$	$3.7 \times 10^{-4}$	$9.4 \times 10^8$	$4.0 \times 10^{-13}$
2: Launch	—	—	—	—	—	—
3: Pre-Orbit	—	—	—	$1.4 \times 10^{-6}$	$1.0 \times 10^3$	$1.4 \times 10^{-9}$
4: Orbit	—	—	—	$1.6 \times 10^{-5}$	$1.0 \times 10^4$	$1.6 \times 10^{-9}$
5: Escape	—	—	—	—	—	—
<b>Overall Mission</b>	<b><math>1.9 \times 10^{-4}</math></b>	<b><math>3.7 \times 10^5</math></b>	<b><math>5.1 \times 10^{-10}</math></b>	<b><math>3.9 \times 10^{-4}</math></b>	<b><math>9.0 \times 10^8</math></b>	<b><math>4.3 \times 10^{-13}</math></b>

Source: DOE 2005

- (a) Phases 0 and 1: within 100 km (62 mi) of the launch pad.
- (b) Phases 0, 1 and 2: within approximately 23° North and 30° North Latitude; Phase 3: southern Africa; Phase 4: land impacts between 28° North and 28° South Latitude.
- (c) Number of persons exposed (order of magnitude estimate).
- (d) Mission risk contribution divided by number of persons exposed.

Note: Differences in summations may be due to rounding.

#### 4.1.5 Radiological Contingency Response Planning

Prior to launch of the New Horizons mission, a comprehensive set of plans would be developed by NASA to ensure that any launch accident could be met with a well-developed and tested response. NASA's plans would be developed in accordance with the National Response Plan (NRP) and the NRP Radiological Incident Annex with the combined efforts of the U.S. Department of Homeland Security (DHS), the DHS's Federal Emergency Management Agency, DOE, the U.S. Department of Defense (DOD), the U.S. Department of State (DOS), the EPA, the State of Florida, Brevard County, and local organizations involved in an emergency response.

The plans would be tested prior to launch in exercises designed to verify the response interfaces, command channels, and field responses to ensure that the various organizations would be prepared to respond in the unlikely event of a launch accident. NASA would be the Principal Technical Agency, working with the DHS to coordinate the entire federal response for launch accidents occurring within United States jurisdiction. Should a release of radioactive material occur in the launch area, the State of Florida, Brevard County, and local governments would determine an appropriate course of action for any off-site plans (such as sheltering in place, evacuation, exclusion of people from contaminated land areas, or no action required) and have full access to the DHS-

coordinated federal response. For accidents outside United States jurisdiction, NASA would assist the DOS in coordinating the United States' response via diplomatic channels and using federal resources as requested.

To manage the radiological contingency response, NASA would establish a Radiological Control Center (RADCC) at KSC prior to and during the mission launch. The RADCC would be where NASA's and DHS's coordination efforts would be managed. The RADCC would also be used to coordinate the initial federal response to a radiological contingency once the vehicle has left the launch site area until the New Horizons spacecraft has left Earth orbit. Participation in the RADCC would include NASA, DHS, DOE, DOD, DOS, the EPA, USAF, the National Oceanic and Atmospheric Administration, the State of Florida, and Brevard County. An additional off-site location would be established from which radiological monitoring and assessment could be conducted.

If impact occurs in the ocean, NASA would work with the DHS, the DHS's U.S. Coast Guard, the U.S. Navy, and DOE to initiate security measures and search and retrieval operations. Efforts to recover the RTG or its components would be based on technological feasibility and any potential health hazard presented to recovery personnel and the environment.

#### **4.2 ENVIRONMENTAL IMPACTS OF THE NO ACTION ALTERNATIVE**

Under the No Action Alternative, preparations for the proposed New Horizons mission would be discontinued and the mission would not be implemented. Environmental impacts associated with preparation of the proposed New Horizons spacecraft and the processing of the launch vehicle would not occur. There would be no local or global launch-related environmental impacts.

There would be no close reconnaissance of Pluto, Charon, or any objects within the Kuiper Belt. The proposed high-priority science to be performed at Pluto and Charon (see Section 1.2) is time-critical because of long-term seasonal changes in the surfaces and atmospheres of both bodies. Achieving objectives involving surface mapping and surface composition mapping would be significantly compromised if a spacecraft does not arrive at the Pluto-Charon system before this system recedes too far from the Sun. More of the surfaces of Pluto and Charon will be in permanent shadow each year until 2042. Furthermore, Pluto's withdrawal from perihelion is widely anticipated to result in substantial decline, if not complete collapse, of its atmosphere. Much of the atmospheric science would be lost if a spacecraft cannot arrive before the atmosphere significantly declines or completely collapses. Once that happens, fulfilling this science objective would have to wait until Pluto's next perihelion passage in 248 years. Canceling the New Horizons mission would create a significant gap in NASA's objectives for exploring the solar system.

#### **4.3 CUMULATIVE IMPACTS**

The potential cumulative impacts associated with use of the launch vehicle and facilities addressed within this FEIS have been assessed using currently available information.

Launch of the proposed New Horizons mission would not increase the number of Atlas V launches beyond the scope of previously approved programs from CCAFS (USAF 1998, USAF 2000).

Various components of the spacecraft and launch vehicle for the proposed New Horizons mission would be manufactured at different sites in the United States, with final integration of the components occurring at KSC and CCAFS. Each of these sites would be required to follow applicable Federal, State, and local regulations governing areas such as air pollution, noise ordinances, wastewater disposal, pollution prevention, disposal of hazardous waste, and worker safety and health (see Section 4.8). Spacecraft and launch vehicle manufacturing are specialized activities with only a limited number of units manufactured each year. While such activities could generate air pollutants, noise, and hazardous waste, any quantities would be small compared to major industrial activities and subject to the appropriate Federal, State, and local environmental laws and regulations pertinent to the individual manufacturing facilities.

The use of the facilities at KSC and CCAFS for processing the New Horizons spacecraft, launch vehicle components, and for launch of the mission would be consistent with existing land uses at each site. No new processing facilities for the New Horizons mission are anticipated at either KSC or CCAFS, and any impacts from their use are expected to be within the scope of previously approved programs (e.g., USAF 1998, USAF 2000, NASA 2002). Implementing the New Horizons mission would be unlikely to add new jobs to the workforce at either site.

Launching the New Horizons spacecraft would principally contribute to exhaust emission impacts on and near SLC-41 at CCAFS. The USAF has monitored numerous launches from CCAFS (USAF 1998). Launch of the Atlas V could result in scorched vegetation, and partially or completely defoliated trees near the launch complex from flame and acidic deposition. Deposition could also impact nearby bodies of water, resulting in temporary elevation of acidity levels. While these impacts may persist with continued use of SLC-41, they are probably not irreversible. At KSC, NASA found that in affected areas near the Space Shuttle launch pads, vegetation reestablished itself after the launches stopped (Schmalzer et. al. 1998).

On a short-term basis, the New Horizons launch would contribute negligible amounts of ozone-depleting chemical compounds to the stratosphere. The USAF has estimated that the total contribution from large expendable launch vehicles with SRBs to the average annual depletion of ozone would be small (approximately 0.014 percent per year). By comparison, a 3 percent to 7 percent annual decrease in ozone at mid-latitudes occurs as a result of the current accumulation of all ozone-depleting substances in the stratosphere (USAF 2000). However, the ozone depletion trail from a launch vehicle has been estimated to be largely temporary, and would be self-healing within a few hours of the vehicle's passage (AIAA 1991). Furthermore, because launches at CCAFS are always separated by at least a few days, combined impacts in the sense of holes in the ozone layer combining or reinforcing one another cannot occur (USAF 2000).

Rocket launches result in the emission of greenhouse gases (CO<sub>2</sub>, trace emissions of nitrous oxides (NO<sub>x</sub>) emitted by the SRBs, and water vapor). The exhaust cloud would

also contain CO, most of which, under the high temperatures of the SRB's exhaust, would quickly react with oxygen in the atmosphere to form CO<sub>2</sub>. Emissions from expendable launch vehicles have been previously estimated (USAF 1998, USAF 2000). These estimates indicate that the annual exhaust emissions from all launch vehicles analyzed would be a very small fraction (on the order of 10<sup>-5</sup> percent) of the total net greenhouse gases emitted annually by the United States (about 6.2x10<sup>12</sup> kg (1.3x10<sup>13</sup> lb) CO<sub>2</sub> equivalent in 2002 (EPA 2004a)). Since the New Horizons mission would not increase the previously analyzed launch rates, launch of the mission would not be anticipated to contribute further to the accumulation of greenhouse gases from expendable launch vehicles.

Other activities on or near CCAFS that are not connected with the New Horizons mission that could occur during this timeframe includes the proposed development and construction of the International Space Research Park (ISRP) located on 160 hectares (400 acres) of KSC. These and other potential construction activities at and in the vicinity of CCAFS could potentially contribute to increases in noise, particulates and dust, solid waste disposal, and the potential for involving wetlands and endangered species. An EIS for the ISRP has been prepared. It is anticipated that, should NASA approve this project, phased construction would occur over the next 20 to 25 years.

No cumulative impacts would occur under the No Action Alternative.

#### **4.4 ENVIRONMENTAL EFFECTS THAT CANNOT BE AVOIDED**

At lift-off and during ascent, the Atlas V main engine and SRBs would produce Al<sub>2</sub>O<sub>3</sub>, CO, HCl, and relatively smaller amounts of CO<sub>2</sub>, H<sub>2</sub>, H<sub>2</sub>O, N<sub>2</sub>, Cl and NO<sub>x</sub>. The exhaust cloud would be concentrated near the launch pad during the first moments of launch. Thereafter, the exhaust cloud would be transported downwind and upward, eventually dissipating to background concentrations.

Biota in the immediate vicinity of the SLC-41 launch pad could be damaged or killed by the intense heat and HCl deposition from the exhaust cloud. No long-term adverse effects to biota would be anticipated. Al<sub>2</sub>O<sub>3</sub> particulates from the SRBs would also be deposited on soils and nearby surface waters at the launch site as the exhaust cloud travels downwind.

#### **4.5 INCOMPLETE OR UNAVAILABLE INFORMATION**

This EIS has been developed before final preparations are completed for the proposed New Horizons mission. The primary areas of either incomplete or unavailable information include the following items.

This EIS evaluates postulated launch accidents that could potentially result in a release of PuO<sub>2</sub> from the RTG. The risk assessment performed by DOE and presented in this EIS has made use of the results of risk analyses for previous NASA missions. The results from these prior missions have been scaled and combined with additional analysis to develop risk estimates for the New Horizon mission. A detailed risk analysis that reflects the actual mission conditions, using procedures and techniques comparable to those used for earlier missions, has not yet been completed.

Several technical issues that could impact the results presented in this DEIS are under continuing evaluation. These issues could not be fully addressed in the risk assessment; best engineering judgment was used to address these issues and their impact on the risk estimate for the New Horizons mission. The important issues that were addressed in this manner and that are the subject of continuing evaluation include:

- the severity of the solid propellant fire environment and its potential effect on the release of PuO<sub>2</sub> from the RTG;
- the behavior of solid PuO<sub>2</sub> and PuO<sub>2</sub> vapor in the fire environment and the potential for PuO<sub>2</sub> vapor to permeate the graphite components in the RTG; and,
- the release characteristics, under postulated accident conditions, of older PuO<sub>2</sub> extracted from the spare RTG built for the Galileo mission.

Under Presidential Directive/National Security Council Memorandum 25 (PD/NSC-25), a separate nuclear launch safety review of the New Horizons mission is being conducted by NASA and DOE. As part of this process DOE, is preparing a Final Safety Analysis Report (FSAR) that will include a complete, detailed risk analysis. In preparing the FSAR, DOE is following procedures and using techniques similar to those used in the risk analyses performed for earlier NASA missions using radioisotope devices. An Interagency Nuclear Safety Review Panel (INSRP) has been formed for the New Horizons mission, and is reviewing this safety analysis. Should the FSAR present risk estimates that differ significantly from those presented in this EIS, NASA would consider the new information, and determine the need for additional environmental documentation.

A detailed uncertainty analysis has not been performed as part of the risk assessment prepared for this FEIS. Based on uncertainty analyses performed for previous mission risk assessments (e.g., NASA 1997), parameter and model uncertainties associated with estimating radiological consequences could result in risk estimates that vary from one to two orders of magnitude at the 5 percent and 95 percent confidence levels. The FSAR will include the results of a formal uncertainty analysis, which NASA would also take into consideration.

#### **4.6 RELATIONSHIP BETWEEN SHORT-TERM USES OF THE HUMAN ENVIRONMENT AND THE MAINTENANCE AND ENHANCEMENT OF LONG-TERM PRODUCTIVITY**

##### **4.6.1 Short-Term Uses**

The proposed New Horizons mission would be launched from CCAFS. The short-term affected environment would include this launch complex and surrounding areas. At CCAFS, short-term uses include commercial, NASA and USAF operations, urban communities, a fish and wildlife refuge, citrus groves, residential communities, and recreational areas. The proposed New Horizons mission would be conducted in accordance with past and ongoing NASA and USAF procedures for operations at CCAFS. Should an accident occur causing a radiological release, short-term uses of contaminated areas could be curtailed, pending mitigation.



#### 4.6.2 Long-Term Productivity

No change to land use at CCAFS and the surrounding region is anticipated due to the Proposed Action. The region would continue to support human habitation and activities, wildlife habitats, citrus groves, grazing and agricultural land, and cultural, historic and archaeological areas. No long-term effects on these uses are anticipated because of the Proposed Action. However, should an accident cause a radiological release, the long-term productivity of contaminated land areas could be impacted, pending mitigation.

The successful completion of the proposed New Horizons mission would benefit science and the United States space program, which is important to the economic stability of the area. In addition to the localized economic benefits from the proactive small and small disadvantaged business plan, implementing this mission has broader socioeconomic benefits. These include technology spin-offs, such as low power digital receivers, to industry and other space missions, maintaining the unique capability of the United States to conduct complex outer planetary missions by a large number of scientists and engineers, and supporting the continued scientific development of graduate students in a number of universities and colleges. Furthermore, comprehensive formal and informal education programs would be conducted as education and public outreach efforts, and proactive small and small disadvantaged business plans would be available to small disadvantaged businesses. Data and images acquired by the New Horizons mission would be made available to the general public, schools, and other institutions via a broad variety of media, including the Internet.

### **4.7 IRREVERSIBLE AND IRRETRIEVABLE COMMITMENT OF RESOURCES**

An irretrievable resource commitment results when a spent resource cannot be replaced within a reasonable period of time. For the Proposed Action, quantities of various resources, including energy, fuels, and other materials, would be irreversibly and irretrievably committed. The use of these resources would be associated with the fabrication, launch, and operation of the proposed New Horizons mission.

#### 4.7.1 Energy and Fuels

Fabrication of the New Horizons spacecraft and the Atlas V would use electrical and fossil-fuel energy. This use constitutes an irretrievable commitment of resources but would not impose any significant energy impacts. The launch and operation of the spacecraft would consume solid and liquid propellant and related fluids. The solid propellant ingredients would be ammonium perchlorate, aluminum powder, and HTPB binder. The liquid substances would include RP-1, hydrazine, LH<sub>2</sub>, and LO<sub>2</sub>. The quantities that would be used are discussed in Section 2.1.5.

#### 4.7.2 Other Materials

The total quantities of other materials used in the proposed New Horizons mission that would be irreversibly and irretrievably committed are relatively minor. Typically, these materials include steel, aluminum, titanium, iron, molybdenum, plastic, glass, nickel, chromium, lead, zinc, and copper. Less common materials may include small quantities

of silver, mercury, gold, rhodium, gallium, germanium, hafnium, niobium, platinum, iridium, plutonium and tantalum.

#### **4.8 ENVIRONMENTAL COMPLIANCE AT CCAFS**

This section presents an overview of environmental laws, regulations, reviews and consultation requirements applicable to operations at CCAFS, and includes permits, licenses, and approvals. The information presented is summarized from the *Final Environmental Impact Statement for the Evolved Expendable Launch Vehicle Program* (USAF 1998), the *Final Supplemental Environmental Impact Statement for the Evolved Expendable Launch Vehicle Program* (USAF 2000), and NASA's *Final Environmental Assessment for Launch of NASA Routine Payloads on Expendable Launch Vehicles from Cape Canaveral Air Force Station, Florida and Vandenberg Air Force Base, California* (NASA 2002). The referenced documents present the relevant discussions, analyses, potential environmental impacts and applicable mitigation plans within each topic of concern. Launch of the New Horizons mission from CCAFS would follow all applicable requirements, and no new permits, licenses, or approvals would be required.

##### Air Resources

Air permits are required for activities considered as stationary sources having the potential to release air pollutants such as launch support activities (e.g., vehicle preparation, assembly, propellant loading), but are not required for emissions from mobile sources such as launch vehicles during liftoff and ascent. Existing equipment and services would be used.

CCAFS currently operates under Title V (40 CFR 70) of the Clean Air Act, as amended (42 U.S.C. 7401 et seq.), as a single facility. Commercial launch service providers are required to obtain Title V permits for their operations.

##### Water Resources

The Clean Water Act, as amended (33 U.S.C. 1251 et seq.), provides regulatory guidelines for water quality.

Wastewater at CCAFS is discharged in accordance with the National Pollutant Discharge Elimination System permit conditions. Water used during launch would be discharged under a Florida Department of Environmental Protection permit or disposed by a certified contractor.

##### Floodplains and Wetlands

Executive Order (EO) 11988, *Floodplain Management*, and EO 11990, *Protection of Wetlands*, would be followed. No added impacts to floodplains and wetlands beyond those normally associated with typical launches would be anticipated. The proposed New Horizons launch would not be anticipated to add substantial impacts beyond those normally associated with any Atlas launch.

### Hazardous Material Management

Hazardous materials are controlled through Federal regulations such as the Comprehensive Environmental Response, Compensation, and Liability Act, as amended (42 U.S.C. 9601 et seq.), the Toxic Substances Control Act, as amended (15 U.S.C. 2601 et seq.), and the Hazardous Material Transportation Act, as amended (49 U.S.C. 1803 et seq.). Air Force Instruction AFI 32-7086, *Hazardous Material Management*, provides guidance for managing hazardous materials.

Hazardous material would be procured and managed by the commercial launch service provider. The 45th Space Wing Operations Plan 32-3, *Hazardous Material Response Plan*, provides guidance for hazardous material spills.

### Hazardous Waste Management

The Resource Conservation and Recovery Act, as amended (42 U.S.C. 6901 et seq.), provides regulatory guidance on managing hazardous wastes. Air Force Instruction AFI 32-7042, *Solid and Hazardous Waste Compliance*, provides guidance on managing hazardous waste. Hazardous wastes must be collected, labeled appropriately, and stored in hazardous waste collection areas prior to disposal.

Hazardous wastes would be managed by the commercial launch service provider or by NASA. The 45th Space Wing Operations Plan 19-14, *Petroleum Products and Hazardous Waste Management Plan* would be followed.

### Pollution Prevention

The Pollution Prevention Act, as amended (42 U.S.C. 13101 et seq.), provides the regulatory framework. Department of Defense Directive 4210.15, *Hazardous Material Pollution Prevention*; USAF Policy Directive AFD 32-70, *Environmental Quality*; and USAF Instruction AFI 32-7080, *Pollution Prevention Program*, provide pollution prevention guidelines. NASA participates in a partnership with the military services called the Joint Group on Pollution Prevention to reduce or eliminate hazardous material or processes.

Pollution prevention guidelines are provided by the 45th Space Wing *Pollution Prevention Program Guide and Pollution Prevention Management Action Plan*.

### Spill Prevention

Hazardous material spills are addressed under the 45th Space Wing Operations Plan 32-3, *Hazardous Materials Response Plan*. The commercial launch service provider will, in most cases, be responsible for clean-up of any released hazardous material. When a spill of a Federally listed oil or petroleum occurs, as per the 45th Space Wing Operations Plan 19-4, *Hazardous Substance Pollution Contingency Plan*, the substance is collected and removed for disposal by a certified contractor.

### Biological Resources

Federal mandates for the conservation of biological resources include, but are not limited to, the Endangered Species Act, as amended (16 U.S.C. 1531 et seq.) (ESA), the Marine Mammal Protection Act, as amended (16 U.S.C. 1361 et seq.), and the

Migratory Bird Treaty Act, as amended (16 U.S.C. 703 et seq.), CCAFS has ESA-listed (endangered or threatened) species. USAF consultations with the U.S. Fish and Wildlife Service and the National Marine Fisheries Service are in place or in process. Established standard practices (e.g., complying with the light management plan for nesting sea turtles and hatchlings) would be observed to minimize impacts to these resources.

#### Coastal Zone Management

The regulatory framework for coastal zone management is provided by the Federal Coastal Zone Management Act, as amended (16 U.S.C. 1451 et seq.), which establishes a national policy to preserve, protect, develop, restore, and enhance the resources of the nation's coastal zone. CCAFS would follow the State of Florida's requirements. No added impacts beyond those normally associated with launches would be anticipated.

#### Cultural Resources

Directives of Section 106 of the National Historic Preservation Act, as amended (16 U.S.C. 470 et seq.), would be followed. The State Historic Preservation Officer and the Federal Advisory Council on Historic Preservation would be consulted, if necessary, to determine if implementation of the New Horizons mission could adversely impact cultural resources within CCAFS, although no adverse impacts are expected.

#### Noise

Regulations and guidelines prescribed by the Noise Control Act, as amended (42 U.S.C. 4901 et seq.), the Occupational Safety and Health Administration, and the National Institute of Occupational Safety and Health would be followed.

#### Worker and Public Safety and Health

OSHA regulations would be followed to ensure worker and public safety and health from excessive noise, exposure to hazardous materials and hazardous wastes, and ingestion of toxic fumes from operations such as fueling. The 45th Space Wing at CCAFS has the responsibility to follow Range Safety guidelines as outlined in the *Range Safety User Requirements Manual* (USAF 2004). RTG handling at the launch site would be performed following applicable regulations as outlined in KHB 1860.1, *KSC Ionizing Radiation Protection Program* (NASA 2001).

## 5 LIST OF PREPARERS

This Final Environmental Impact Statement (FEIS) for the New Horizons Mission was prepared by the Office of Space Science, National Aeronautics and Space Administration (NASA). As a cooperating agency, the U.S. Department Energy (DOE) has contributed expertise in the preparation of this FEIS. The organizations and individuals listed below contributed to the overall effort in the preparation of this document.

### National Aeronautics and Space Administration

Kurt Lindstrom <i>M.S., Public Administration</i>	Program Executive, New Horizons Mission
Denis Bogan <i>PhD, Physical Chemistry</i>	Program Scientist, New Horizons Mission
Ann Clarke <i>PhD, J.D.</i>	Environmental Program Manager
John Giles <i>B.S., Electrical and Mechanical Engineering</i>	Launch Approval Engineering Lead
Thomas Shemanski <i>M.S., Aerospace Systems</i>	Reliability and Launch Approval Engineer

### U.S. Department of Energy

Lyle Rutger <i>M.S., Nuclear Engineering</i>	Nuclear Engineer
---	------------------

### Science Applications International Corporation (Contractor to NASA)

Dennis Ford <i>PhD, Zoology</i>	EIS Project Manager
Daniel Gallagher <i>M.E., Nuclear Engineering</i>	Reliability and Risk Engineer
Douglas Outlaw <i>PhD, Nuclear Physics</i>	Senior Environmental Scientist
Daniel Spadoni <i>MBA</i>	Senior Engineer
Lasantha Wedande <i>M.S., Environmental Management</i>	Environmental Scientist
John Williams <i>PhD, Physics</i>	Environmental Scientist

Applied Physics Laboratory, Johns Hopkins University (Contractor to NASA)

Glen Fountain  
*M.S., Electrical Engineering*                      New Horizons Project Manager

Yale Chang  
*M.S. Mechanical Engineering*                      Professional Staff Engineer

Tetra Tech NUS, Inc. (Contractor to Applied Physics Laboratory)

Henry Firstenberg  
*M. Engineering Science*                      Project Manager

Bart Bartram  
*M.S., Mechanical Engineering/Physics*                      Senior Scientist

California Institute of Technology – Jet Propulsion Laboratory (Contractor to NASA)

Reed Wilcox  
*M.S., City and Regional Planning*                      Manager, Cross-Program Launch Approval  
Engineering

Paul VanDamme  
*M.S., Public Policy*                      Deputy Manager, Cross-Program Launch  
Approval Engineering

Jonathan Stabb  
*M.A., Applied Mathematics*                      New Horizons Launch Approval Engineer

## 6 AGENCIES, ORGANIZATIONS AND INDIVIDUALS CONSULTED

This Final Environmental Impact Statement (FEIS) for the New Horizons mission was preceded by a Draft Environmental Impact Statement (DEIS), which was made available for review and comment by Federal, State, and local agencies and the public on February 25, 2005. The public review and comment period closed on April 11, 2005. Comments were considered during the preparation of the FEIS.

In preparing the EIS, NASA has actively solicited input from a broad range of interested parties. In addition to publication in the *Federal Register* of a Notice of Availability (70 FR 9387) for the DEIS, NASA mailed copies of the DEIS directly to agencies, organizations, and individuals who may have interest in environmental impacts and alternatives associated with the New Horizons mission. In addition, the DEIS was publicly available in electronic format on NASA's web site.

Comments on the DEIS were solicited or received from the following:

### **Federal Agencies**

Council on Environmental Quality  
National Science Foundation  
Office of Management and Budget  
U.S. Department of Agriculture  
U.S. Department of the Air Force  
U.S. Department of Commerce  
    National Oceanic and Atmospheric Administration  
    National Marine Fisheries Service (NOAA Fisheries)  
U.S. Department of Health and Human Services  
    Centers for Disease Control and Prevention  
    National Cancer Institute  
U.S. Department of Homeland Security  
    Federal Emergency Management Agency  
    U.S. Coast Guard  
U.S. Department of the Interior  
    Fish and Wildlife Service  
    National Park Service  
U.S. Department of State  
U.S. Department of Transportation  
    Federal Aviation Administration  
    Research and Special Programs Administration  
U.S. Environmental Protection Agency  
U.S. Nuclear Regulatory Commission

### **State Agencies**

State of Florida, Office of the Governor  
Florida State Clearinghouse  
East Central Florida Regional Planning Council

## **County Agencies**

Brevard County  
Board of County Commissioners  
Natural Resources Management Office  
Office of Emergency Management  
Planning and Zoning Commission  
Public Safety Department  
Lake County  
Orange County  
Osceola County  
Seminole County  
Volusia County

## **Local Agencies**

Canaveral Port Authority  
City of Cape Canaveral  
City of Cocoa  
City of Cocoa Beach  
City of Kissimmee  
City of Melbourne  
City of Merritt Island  
City of New Smyrna Beach  
City of Orlando  
City of West Melbourne  
City of St. Cloud  
City of Titusville

## **Organizations**

The American Association for the Advancement of Science  
American Astronomical Society  
American Institute of Aeronautics and Astronautics  
American Society of Mechanical Engineers  
Audubon of Florida  
Economic Development Commission of Florida's Space Coast  
Environmental Defense Fund  
Environmental Defense Institute, Inc.  
Federation of American Scientists  
Friends of the Earth  
Global Network Against Weapons and Nuclear Power in Space  
Greenpeace  
Indian River Audubon Society  
National Space Society  
National Wildlife Federation  
Natural Resources Defense Council  
The Planetary Society  
Sierra Club



## Union of Concerned Scientists

### Individuals

The following individuals have been sent a copy of the FEIS or have been notified by electronic mail that the FEIS is available in electronic format on NASA's web site.

Allen Tolson	Diana Oleskevich, CSJA
Anthony Ehrlich	Alan Oniskor
Chad Barklay	Don Pratt
Daniel P. Kramer	Marian Ring
Russell D. Hoffman	Molly Rush
Timothy J. Hoye	Wolfgang Schlupp-Hauck
Victoria Nichols	Alice Slater
Regina Hagen	Phoebe Ann Sorgen
Barry Pugh	Rev. Dr. Donald C. Thompson and Jane Riley Thompson
Chip Welch	Andrea Van Liew
Robert C. Anderson	Nancy Andon
Sheila Baker	Sally Breen
Lon Ball	Frank Chase
Winthrop Dexter Bellamy, PhD	Graham Cowan
Patricia Birnie	Laurie Cross
Jerry Bloomer	Andy D (complete name not provided)
Rev. Prema Camp	Greg Delanty
Emily S. Chasse	Eliot Diamond
Joy Crocker	Joan W. Drake
Judy Cumbee	Robert L. duRivage
William DeTuncq	Toni Ehrlich
C. Knuth Fischer	Holly Gwinn Graham
Dr. and Mrs. A. A. Fischer	Sagesse Gwin
Bobbie D. Flowers	Cynthia Heil
B. Geary	Annemarie Hindinger
Ernest Goitein	Kevin (complete name not provided)
Sidney J. Goodman, P.E.	Thomas Lash
Kay Hagan	Marvin I. Lewis
Kevin Head	Sally Light, JD
Lynda A. Hernandez	Anne Logue
Janet Hutto	R.K. Marovitz
Karl Johanson	John Davidson Miller
Leah R. Karpen	Daniel Moss
Fern Katz	Stephanie Noakes
Laurence Kirby	Chris Pearson
David Kuehn	David L. Swain
Dave Lacey	June Swan
John LaForge	Sherry Tuell
Sr. Gladys Marhefka, SGM	Millennium Twain
Bill Mills	Heather Woollard
Glen Milner	

Steven C. Buttgereit  
Serge J. Uccetta  
Michal Snyder  
Alan Stahler  
Dan Garcia  
Andreas Goetzfried  
Laura Donovan  
Madelyne G. Donovan  
Charles Tatro  
Tom LaForge  
Richard M. Bianculli, Jr.  
Don Ross  
David P. Gontar  
Dawn Greenfield  
Glenn (complete name not provided)  
Gladys Tiffany  
Don Pratt  
Maxine Caron and Gareth Smith  
Ann Link  
Daniel Rafferty  
Ruth Zalph  
Celia Santowski  
Ben Wolf  
Sally Breen  
Carl Carlsson  
Mary West  
Jon Weislogel  
Stephen Johnson  
Murray Kiok  
Brian Dunbar  
Wilfred Phillips  
Jane Hanna  
Noemy Sanchez  
Nicholas Blackwell  
Tracy McLellan  
Judy Hogan  
Nate Looney  
Miriam Welly Elliott  
Cheryl Niccoli  
Timothy Kyger  
Laurence Kirby  
Daryl Cockburn  
Adam Pope  
Stacey Gasson  
William I. Peltz  
Emmy Lou Cholak

Johnny Jupiter  
Paul Winkler  
Byron R. Winchell  
William T. Dixon  
Jim Licari  
H.B. Finger  
Bart Dias  
Vince Robert Murphy  
Bill Gekler  
Chris Bailey  
Jonathan Hendler  
Clarence A. Bolin  
Betsy McCall  
Jeanne Christensen  
Jack Clark  
Keith B. Helm  
Paul Salo  
Morgan Todd  
Hans Edsberg  
Chris Rempel  
Tracy Eckels  
D. Scott Kee  
Mike Giardini  
Greg Nielsen  
T. Dickinson  
Salvatore Trentacoste  
Michael G. Montague  
Patrick O'Connor  
David Martin  
James Velasquez  
Richard Schumacher  
Jeffrey L. Patten  
Christine Heller  
Mike Giardini  
Paul Maunder  
Isabel Denham  
Dirk Neyhart  
Wolfgang Schlupp-Hauck  
Phoebe Anne Sorgen  
Rhodes Thompson  
Mary Beth Sullivan  
Mary Van Valin  
Mitsuo Okamoto  
Lynda A. Hernandez  
Wayne Rainy

Margaret Maier  
Cindy Shapiro  
Steen Eiler Jørgensen

In addition to the individuals listed above, a notification that the FEIS is available in electronic format on NASA's web site was sent by electronic mail to the 867 individuals who submitted electronic comment numbers E92, E93, and E94. Those individuals are listed following the three submissions in Table D-3 in Appendix D of this FEIS.

This page intentionally left blank.

## 7 INDEX

### A

Abbreviations, xix

Accident

- cleanup costs, ix, 2-32, 4-32–33
- configurations, viii, 4-15–20, 4-22–23, 4-25, 4-27–28, 4-30
- consequences, vii, ix–xi, 2-24–25, 2-28–32, 4-11–13, 4-26–33
- environments, viii, ix, 2-11, 2-25–27, 4-13–18, 4-21–24, 4-27
- probabilities, viii–xi, 2-25–29, 2-31, 4-2, 4-14, 4-17–19, 4-24–25, 4-27, 4-36

Acronyms, xix

Affected Environment, 3-1

Agencies and Individuals Consulted, 5-1

Air quality, vii, 2-23–24, 3-4–6, 4-3–4, 4-12, 4-42

Alternatives

- considered but not evaluated further, 2-18–22
- comparison of, 2-22
- No Action, v–vii, 2-1, 2-18, 2-22–25, 4-37, 4-39
- Proposed Action, v–vii, ix, xii, 2-1, 2-18–19, 2-22–25, 3-1, 3-4, 4-1, 4-34, 4-41

Aluminum oxide (Al<sub>2</sub>O<sub>3</sub>), 2-22–25, 4-4–7, 4-9, 4-12, 4-39

Ambient noise, 3-7

Ammonium perchlorate, 2-14, 4-9, 4-12–13, 4-41

Aquatic preserves, 3-9–10

Aquatic resources, 3-13–14, 4-12

Archaeological resources, 2-23–24, 2-31, 3-2, 3-20, 4-7, 4-41

Astronomical Unit (AU), 1-1, 1-3, 2-5, 2-20, 2-22

Atlas V 551, vi, 2-1–2, 2-13, 4-1, 4-10

Atomic Energy Act, 4-33

Automatic Destruct System (ADS), 2-15, 4-18

Average individual risk, xii, 2-33, 4-34–36

### B

Background radiation, 3-24–26

Benefits of mission, 1-4, 4-41

Biological resources, 2-23, 3-12–16, 4-6–7, 4-43

Breakup System (BUS), 2-15, 2-20, 2-26, 4-15–19, 4-22–23, 4-40

### C

Cape Canaveral Air Force Station (CCAFS), v–vii, 1-1, 2-1–2, 2-4, 2-11–12, 2-16–17, 2-23–24, 2-26, 3-1–20, 4-1, 4-3–8, 4-11–14, 4-32, 4-37–44

Cancer fatalities (see Latent cancer fatalities)

Carbon dioxide (CO<sub>2</sub>), 2-24–25, 4-4, 4-9–10, 4-12, 4-38–39

Carbon monoxide (CO), 1-2, 1-5, 2-22, 2-24–25, 3-4, 3-6, 3-21–22, 4-4, 4-9–10, 4-12, 4-38–39

Centaur (second stage), 2-12–17, 4-2, 4-10–11, 4-18–20, 4-23, 4-25–26, 4-28

Centaur Automatic Destruct System (CADS), 2-15, 4-18, 4-23

Charon, v–vi, xii, 1-1–6, 2-1–3, 2-6–7, 2-18, 2-20, 4-1, 4-37

Clean Air Act, 3-4, 4-42

Clean Water Act, 4-42

Cleanup of contaminated areas, ix, 2-32, 4-32–33

Climate

- global, 2-23, 4-8–10
- regional, 3-4

Collective dose, xi, 2-28–30, 4-26, 4-28–31  
 Command Destruct System (CDS), 2-15, 2-17, 4-17–18, 4-23  
 Consultations with agencies and individuals, 5-1  
 Contingency response planning, 2-33–35, 4-36–37  
 Contributors, 6-1  
 Council on Environmental Quality (CEQ), 1-1, 3-17  
 Critical habitat, 3-16  
 Cultural resources, 2-23–24, 2-31, 3-20, 4-7, 4-41, 4-44  
 Cumulative impacts, 4-37–39

**D**

Debris

- launch accident, vii, 2-17, 2-25, 2-27, 4-12–13, 4-17, 4-25, 4-30
- normal launch, 2-16, 3-20, 4-8
- orbital and reentry, 4-10

Delta-V Earth Gravity Assist ( $\Delta$ VEGA), 2-20–21

Dose

- average background, 2-29, 3-24–25, 4-29
- collective, xi, 2-28–30, 4-26, 4-28–31
- general, 3-24
- maximum individual, ix–x, 2-28–30, 4-16, 4-26, 4-28–30

**E**

Eagles, 3-15  
 Economic impacts, ix, 2-32, 4-7, 4-33, 4-41  
 Electromagnetic radiation, 2-18  
 Emergency services, 3-19  
 Endangered species, 2-23–24, 3-14–16, 4-7, 4-39, 4-44

Environmental impacts

- normal launch, vi–vii, 2-22–24, 4-3–10, 4-37–39
- nonradiological accidents, vii, 2-24–25, 4-10–13
- preparing for launch, 4-2–3
- radiological accidents, vii–xii, 2-25–32, 4-13–33

Environmental justice, 4-7, C-1

Essential fish habitat, 2-23, 3-13, 4-13

Exhaust emissions (see Launch emissions)

**F**

Final Safety Analysis Report (FSAR), vii, ix, 2-26, 4-14, 4-27, 4-40

First stage, 2-13, 2-15–16, 4-2, 4-3–6, 4-8, 4-10–11, 4-17–18, 4-20–21

Flight Termination System (FTS), 2-15, 4-17–20, 4-23–25, 4-29, 4-31

Floodplain, 3-7, 4-42

**G**

General Purpose Heat Source (GPHS), 2-4, 2-7–10

Geology, v, 1-3, 1-5, 2-6, 2-23, 3-7, 4-5

Global environment, 3-21–26

Global climate change, 4-8–10

Global warming, 4-9

Glossary, A-1

Gravity assist trajectories, 2-20–21

Greenhouse gases, 4-9–10, 4-38–39

Groundwater, 2-23, 3-9, 3-11, 4-5

**H**

Health effects, 2-28–33, 4-16–17, 4-26–31, 4-33–36

Historical resources, 2-23–24, 3-2

Hydrazine, 2-4, 2-12, 2-14, 2-16, 2-24, 4-11–13, 4-41

Hydrogen chloride (HCl), vii, 2-22–25, 4-4–12, 4-39

Hydrology, 2-23, 3-7, 4-5–6

hydroxyl-terminated polybutadiene binder (HTPB), 2-14, 4-41

**I**

Incomplete or unavailable information, 4-39–40

Interagency Nuclear Safety Review Panel (INSRP), 2-26, 4-40

**J**

Jupiter Gravity Assist (JGA), v, 2-2, 2-5, 2-21

**K**

Kennedy Space Center (KSC), 2-11–12, 2-35, 3-1, 3-3–4, 3-7, 3-9, 3-13, 3-18–20, 4-3, 4-6, 4-36–39, 4-44

Kuiper Belt Objects (KBO), v–vi, xii, 1-2–6, 2-1, 2-3, 2-5, 2-18, 4-1

**L**

Land use, 2-23, 2-32, 3-1–4, 3-21–13, 4-3, 4-33, 4-41

Latent cancer fatalities, ix–xi, 2-29–30, 4-16 (see also Health effects)

Launch emissions, vi–viii, 2-17, 2-22–25, 3-21, 4-3–6, 4-8–10, 4-12, 4-38–39, 4-42

Launch phases (see Mission phases)

Launch profile, 2-16–17

Launch vehicle processing, 2-16, 4-2–3, 4-38

Launch vehicles

- Atlas, 2-13, 3-21, 4-2–3, 4-6
- Atlas V, vi–vii, 2-1–2, 2-4, 2-11–18, 2-21–22, 2-24, 2-27, 2-31, 3-4, 3-13, 4-1–7, 4-9–14, 4-16–19, 4-22, 4-37–39, 4-41
- Delta, 2-12, 2-26, 4-6–7, 4-14
- Titan, 2-11, 3-21, 4-2, 4-6–7

Lightning, 2-18

Liquid propellant, vii, 2-11, 2-13–17, 2-24–25, 4-3, 4-9, 4-11–12, 4-18, 4-21, 4-24, 4-41

Liquid hydrogen (LH<sub>2</sub>), 2-14, 2-16, 2-24, 4-11–12, 4-19, 4-41

Liquid oxygen (LO<sub>2</sub>), 2-14, 2-16, 2-24, 4-3, 4-11–12, 4-19, 4-41

Low thrust trajectories, 2-21–22

**M**

Manatee, 3-14

Maximally exposed individual, xi, 2-30–31, 2-33, 4-30, 4-35

Maximum individual dose, ix–x, 2-28–30, 4-16, 4-26, 4-28–30

Mission Flight Control Officer (MFCO), 2-17, 4-18

Mission

- description, v, 2-1–4
- objectives, v–vi, 1-3–6, 2-1, 4-1
- phases, 2-27–32, 4-17, 4-19–20, 4-23–30, 4-32, 4-34–35
- risk, 2-32–33, 4-34–35

**N**

National Ambient Air Quality Standards (NAAQS), 3-4, 4-4

National Environmental Policy Act (NEPA), v, 1-1, 1-6, 3-1

National Response Plan, 2-33, 4-36

New Horizons mission

- description, v, 2-1–4
- objectives, v–vi, 1-3–6, 2-1, 4-1
- science instruments, 2-4, 2-6
- spacecraft, 2-4

Nitrogen dioxide (NO<sub>2</sub>), 3-4, 3-6

Nitrogen oxides (NO<sub>x</sub>), 2-24–25, 3-22, 4-4, 4-9–10, 4-38–39

Nitrous oxides (N<sub>2</sub>O), 4-9–10

No Action Alternative, v–vii, 2-1, 2-18, 2-22–25, 4-37, 4-39

Noise, 2-23–24, 4-4–5, 4-7, 4-38–39, 4-44

Notice of Intent, 1-6

Nuclear-electric propulsion, 2-21–22

**O**

Offshore environment, 3-11–12, 4-6  
 Outstanding Florida Waters, 3-9–10  
 Ozone (O<sub>3</sub>), vii, 2-23–24, 3-4, 3-6,  
 3-21–22, 4-9–9, 4-38

**P**

Particulates, 2-22–25, 3-4–6, 3-21–22,  
 4-4–7, 4-9, 4-12, 4-39  
 Payload fairing (PLF), 2-12–14, 2-16,  
 4-6, 4-8, 4-10, 4-20  
 Perchlorate contamination, 3-11, 4-12  
 Pluto, v–vii, xii, 1-1–6, 2-1–7, 2-14,  
 2-16, 2-18, 2-20–22, 2-24–25, 2-33,  
 3-1, 4-1, 4-26, 4-37, 6-1

Plutonium

- environmental effects, B-1
- worldwide levels, 3-23–26

Plutonium (Pu)-238, vii, 2-7, 2-9, 2-19,  
 2-27, 3-24–26, 4-14, 4-31

Plutonium dioxide (PuO<sub>2</sub>), v, vii–ix, xi,  
 2-7, 2-9–11, 2-18–19, 2-25–32, 4-1,  
 4-10, 4-13–16, 4-18–19, 4-21–26,  
 4-29–33, 4-39–40

Population

- global, 3-23
- regional, 3-16–18
- risk, 2-33

Pre-launch activities, vii, 2-12, 2-16,  
 4-2–3, 4-37–38

Price-Anderson Act, 2-32, 4-33

Proposed Action

- description, 2-1–18
- need, 1-4–6
- purpose, 1-3–4

Purpose and Need for Action, 1-1

**R**

Radiological Control Center (RADCC),  
 2-35, 4-36–37

Radioisotope Thermoelectric Generator  
 (RTG), v, vii–ix, 1-6–7, 2-4, 2-7–12,

2-16, 2-18–19, 2-22, 2-25–27, 2-30–  
 32, 2-35, 3-25, 4-1, 4-3, 4-10, 4-13–  
 19, 4-21–25, 4-28–34, 4-37, 4-39–  
 40, 4-44

Range Safety, vii, 2-15, 2-17, 3-20, 4-8,  
 4-11–12, 4-18, 4-29, 4-44

References, 8-1

Regional environment, 3-1–21

Risk

- average individual, xii, 2-33,  
 4-34–36
- general, 2-32, 4-34
- mission, 2-32–33, 4-34–35
- population, 2-33

Rocket Propellant (RP-1), 2-13, 2-16,  
 2-24, 4-3, 4-6, 4-11–13, 4-41

**S**

Safety

- public, vii, 2-17, 2-24–25, 3-19–  
 20, 4-4, 4-7–8, 4-11–12, 4-44
- Range (see Range Safety)
- worker, vii, 2-17, 2-24, 4-8,  
 4-11–12, 4-44

Science instruments, 2-4, 2-6

Second stage (see Centaur)

Socioeconomics, 2-23, 3-16, 4-7

Soils, 3-7, 4-5

Solid propellant, ix, 2-13–14, 2-23,  
 2-25–27, 4-3, 4-7, 4-11–12, 4-15–17,  
 4-22–24, 4-29, 4-31, 4-34, 4-40

Solar power, 2-20

Solar-electric propulsion, 2-21–22

Solid rocket booster (SRB), viii, 2-13–  
 16, 2-22, 4-3–4, 4-6, 4-8–13, 4-17–  
 18, 4-20, 4-22–25, 4-30, 4-34, 4-38–  
 39

Solid rocket motor (SRM), x, 2-14–16,  
 2-26, 4-15, 4-18, 4-20–23, 4-25–26,  
 4-30, 4-34, 4-40

Sonic booms, 2-23–24, 4-5, 4-7

Source term, viii, 4-16, 4-21, 4-24–27,  
 4-36



Spacecraft description, 2-4  
Spacecraft processing, 2-12, 4-2–3,  
4-38  
Space Launch Complex (SLC)-41, 2-2,  
2-11–12, 2-16, 3-4, 3-7, 3-14, 3-20,  
4-1, 4-3, 4-5–7, 4-17, 4-34, 4-38–39  
Stage 1 (see First stage)  
Stage 2 (see Centaur)  
Stage 3 (see Third stage)  
STAR<sup>®</sup> 48B, 2-14  
Stratospheric ozone, vii, 2-24, 3-21–22,  
4-9, 4-38  
Surface water, vii, 2-25, 3-7–9, 4-5–6,  
4-31

**T**

Terrestrial resources, 3-12–13, 4-6–7  
Third stage, viii, x, 2-12–16, 2-18, 2-20–  
21, 2-26, 4-2, 4-10, 4-12, 4-15–23, 4-  
25–26, 4-28, 4-30, 4-34, 4-40  
Threatened and endangered species,  
2-23–24, 3-14–16, 4-17, 4-44

Toxic gases, vii, 2-17, 2-25, 4-8, 4-12  
(see also Launch emissions)  
Turtles, 3-13–15, 4-7, 4-44

**U**

Uncertainty, xi, 4-30, 4-36, 4-40  
Upper atmospheric impacts  
– stratosphere, vii, 2-24, 4-9,  
4-38–39  
– troposphere, 4-9

**W**

Water  
– currents, 3-11  
– groundwater, 2-23, 3-9, 3-11, 4-5  
– quality, 2-23, 2-25, 3-7, 3-9,  
3-11, 4-5–6, 4-42  
– surface, vii, 2-25, 3-7–9, 4-5–6,  
4-31  
Wetlands, 2-31, 3-7, 3-12–13, 4-32,  
4-39, 4-42

This page intentionally left blank.

## 8 REFERENCES

- AEC 1974. U.S. Atomic Energy Commission. *Plutonium and Other Transuranium Elements, Sources, Environmental Distribution and Biomedical Effects*. USAEC WASH 1359. December 1984.
- AIAA 1991. American Institute of Aeronautics and Astronautics. *Atmospheric Effects of Chemical Rocket Propulsion*. Report of an AIAA Workshop, Sacramento, California. 1991.
- AIHA 1998. American Industrial Hygiene Association. *Emergency Response Planning Guideline for Hydrogen Chloride*. March 30, 1998.
- APL 2002. Applied Physics Laboratory. *Assessment of Solar Electric Propulsion: Options and Impacts for New Horizons*. The Johns Hopkins University Applied Physics Laboratory. Laurel, MD. September 13, 2002.
- APL 2003a. Applied Physics Laboratory. *Alternative Power Sources for the New Horizons Pluto Kuiper Belt Project*. The Johns Hopkins University Applied Physics Laboratory. Laurel, MD. April 14, 2003.
- APL 2003b. Applied Physics Laboratory. *Alternative Mission Designs for the Pluto-Kuiper Belt Mission*. The Johns Hopkins University Applied Physics Laboratory. Laurel, MD. April 24, 2003.
- APL 2003c. Applied Physics Laboratory. *New Horizons Earth Impact Study*. The Johns Hopkins University Applied Physics Laboratory. Laurel, MD. May 8, 2003.
- APL 2003d. Applied Physics Laboratory. *New Horizons Pluto-Kuiper Belt Mission And System Description*. The Johns Hopkins University Applied Physics Laboratory. Laurel, MD. October 27, 2003.
- ASCA 2005. ASCA, Inc. *Pluto New Horizons Atlas V 551 Launch Accident Probability Data For EIS Risk Assessment*. AR 05-03. February 4, 2005.
- Bartram 2004. Personal communication from B. Bartram, Tetra Tech NUS, Inc., to D. Spadoni, Science Applications International Corporation. Regarding global population growth estimators. January 2, 2004.
- BEBR 2001. Bureau of Economic and Business Research. *Florida Statistical Abstract 2001*. Warrington College of Business Administration, University of Florida. Gainesville, Florida. 2001.
- BEBR 2002. Bureau of Economic and Business Research. *Florida Population Studies, Volume 35, No. 2*. Available at: <http://www.ecfrpc.org/Countytop.html>. February 2002.
- Bennett 1981. G.L. Bennett, *et al.* *Development and Use of Nuclear Power Sources for Space Applications*. Journal of the Astronautical Sciences, Vol. XXIX, No. 4, p 328. October – December 1981.

- BLS 2000. U.S. Bureau of Labor Statistics. *Fatal Occupational Injuries by Industry and Event or Exposure, 2000*. 2000.
- Chambers 2003. Personal communication from A.L. Chambers, Environmental Planning and Conservation, 45 CES/CEVP, Patrick Air Force Base, Florida, to D. Spadoni, Science Applications International Corporation. Regarding workforce levels at Cape Canaveral Air Force Station. October 22, 2003.
- Chanin et al. 1996. Chanin D.I. and W.B. Murfin. *Site Restoration: Estimation of Attributable Costs From Plutonium-Dispersion Accidents*. Prepared for Transportation Systems Analysis Department, Sandia National Laboratories. Albuquerque, NM. May 1996.
- CEQ 1997. Council on Environmental Quality. *Environmental Justice: Guidance under the National Environmental Policy Act*. Executive Office of the President, Washington, DC. Available at <http://ceq.eh.doe.gov/nepa/regs/guidance.html>. December 10, 1997.
- Code of Federal Regulations. 40 CFR Part 300.430(e)(2). *Remedial Investigation/Feasibility Study and Selection of Remedy*. U.S. Environmental Protection Agency.
- DOC 2001. U.S. Department of Commerce. *Poverty in the United States: 2000*. U.S. Census Bureau, Current Population Reports, series P60-214. Washington, DC. Available at <http://www.census.gov/hhes/www/poverty00.html>. September 2001.
- DOD 2003. U.S. Department of Defense. *Ground-Based Midcourse Defense (GMD) Extended Test Range (ETR) Final Environmental Impact Statement*. Missile Defense Agency. July 2003. Available at <http://www.acq.osd.mil/bmdo/bmdolink/html/enviro.html>.
- DOE 1989a. U.S. Department of Energy. *Final Safety Analysis Report for the Galileo Mission, Volume III, (Book 2) Nuclear Risk Analysis Document. - Appendices*. NUS-5126, Revision 1. January 1989.
- DOE 1989b. U.S. Department of Energy. *Supplement to the Final Safety Analysis Report for the Galileo Mission*. 89SDS4221. August 1989.
- DOE 1990. U.S. Department of Energy. *Final Safety Analysis Report for the Ulysses Mission, Volume I, Reference Design Document*. ULS-FSAR-002. March 1990.
- DOE 1991. U.S. Department of Energy. *Environmental Assessment for Radioisotope Heat Source Fuel Processing and Fabrication*. July 1991.
- DOE 1999. U.S. Department of Energy. *Final Site-wide Environmental Impact Statement for Continued Operation of the Los Alamos National Laboratory*. January 1999.
- DOE 2000. U.S. Department of Energy. *Final Programmatic Environmental Impact Statement for Accomplishing Expanded Civilian Nuclear Energy Research and Development and Isotope Production Missions in the United States, Including the Role of the Fast Flux Test Facility*. DOE/EIS-0310. December 2000.

- DOE 2002a. U.S. Department of Energy. *Space Radioisotope Power Systems, Stirling Radioisotope Generator and Multi-Mission Radioisotope Thermoelectric Generator*. Available at <http://www.nuclear.gov/space/space-pubs.html>. April 2002.
- DOE 2002b. U.S. Department of Energy. *Final Environmental Assessment (EA) for Future Location of the Heat Source/Radioisotope Power System Assembly and Test Operations Currently Located at the Mound Site*. August 2002.
- DOE 2005. U.S. Department of Energy. *Nuclear Risk Assessment for the New Horizons Mission Environmental Impact Statement (Revision C)*. Prepared by Tetra Tech NUS, Inc. for the Office of Space and Defense Power Systems, U.S. Department of Energy. February 2005.
- DOI 2003. U.S. Department of the Interior. *National Register of Historic Places, Florida Index*. National Park Service, Washington, DC. Available at <http://www.cr.nps.gov/nr>. 2003.
- Dreschel and Hall 1986. Dreschel, T.W. and C.R. Hall. *Near-Field Deposition Patterns of Chlorides and Particulates Resulting from launches of the Space Transportation System at John F. Kennedy Space Center*. NASA Technical Memorandum NASA/KSC Biomedical Office. John F. Kennedy Space Center, Florida. 1986.
- EPA 2003a. U.S. Environmental Protection Agency. *National Ambient Air Quality Standards*. Available at <http://www.epa.gov/air/criteria.html>.
- EPA 2003b. U.S. Environmental Protection Agency. *Transmittal of Perchlorate Maps and Table, Updated April, 2003*. Available at [http://www.clu-in.org/contaminantfocus/default.focus/sec/perchlorate/cat/Environmental\\_Occurrence/](http://www.clu-in.org/contaminantfocus/default.focus/sec/perchlorate/cat/Environmental_Occurrence/). May 14, 2003.
- EPA 2004a. U.S. Environmental Protection Agency. *Inventory of U.S. Greenhouse Gas Emissions and Sinks: 1990-2002*. Document Number EPA 430-R-04-003. Washington, DC. April 15, 2004.
- FAC 62-204.240. Florida Administrative Code, Chapter 62, Department of Environmental Protection, Section 62-204 Air Pollution Control - General Provisions, Rule 62-204.240, *Ambient Air Quality Standards*. State of Florida. Available at <http://fac.dos.state.fl.us/>.
- FAC 62-302.700. Florida Administrative Code, Chapter 62, Department of Environmental Protection, Section 62-307, Surface Water Quality Standards, Rule 62-302.700, *Special Protection, Outstanding Florida Waters, Outstanding National Resource Waters*. State of Florida. Available at <http://fac.dos.state.fl.us/>.
- FAC 68C-22. Florida Administrative Code, Chapter 68, Fish and Wildlife Conservation Commission, Section 68C-22, *The Florida Manatee Sanctuary Act*. State of Florida. Available at <http://fac.dos.state.fl.us/>.

FDACS 2003. Florida Department of Agriculture & Consumer Services. *Notes on Florida's Endangered and Threatened Plants*. Division of Plant Industry. 2003. Available at <http://www.doacs.state.fl.us/pi/index.html>.

FDEP 2002. Florida Department of Environmental Protection. *Air Monitoring Report 2002*. State of Florida. Available at: <http://www.dep.state.fl.us/air/publications/techrpt/>.

*Federal Register* (59 FR 13500) 1994. *Designated Critical Habitat; Northern Right Whale; Final Rule*. National Marine Fisheries Service. June 3, 1994.

*Federal Register* (59 FR 66414) 1994. *Federal Radiation Protection Guidance for Exposure of the General Public*. U.S. Environmental Protection Agency. December 23, 1994.

*Federal Register* (62 FR 19883) 1997. *Executive Order 13045. Protection of Children from Environmental Health Risks and Safety Risks*. U.S. Environmental Protection Agency. April 23, 1997.

*Federal Register* (62 FR 39058) 1997. *Radiological Criteria for License Termination*. U.S. Nuclear Regulatory Commission. July 21, 1997.

*Federal Register* (63 FR 53938) 1998. *Notice of Intent to Prepare an Environmental Impact Statement and Conduct Scoping for the Pluto Kuiper Express Mission*. National Aeronautics and Space Administration. October 7, 1998.

*Federal Register* (67 FR 680) 2002. *Endangered and Threatened Wildlife and Plants; Manatee Protection*. Fish and Wildlife Service, U.S. Department of the Interior. January 7, 2002.

*Federal Register* (67 FR 39748) 2002. *Information Update and Reopening of Scoping Period for the Pluto-Kuiper Belt Mission*. National Aeronautics and Space Administration. June 10, 2002.

*Federal Register* (67 FR 68450) 2002. *Endangered and Threatened Wildlife and Plants; Final Rule to Establish Thirteen Additional Manatee Protection Areas in Florida; Final Rule and Proposed Rule*. Fish and Wildlife Service, U.S. Department of the Interior. November 8, 2002.

*Federal Register* (69 FR 23857) 2004. *40 CFR Parts 50, 51 and 80: 8-Hour Ozone National Ambient Air Quality Standards; Final Rules*. U.S. Environmental Protection Agency. April 30, 2004.

*Federal Register* (69 FR 40796) 2004. *Endangered and Threatened Wildlife and Plants; Removal of Federal Protection Status From Two Manatee Protection Areas in Florida*. Fish and Wildlife Service, U.S. Department of the Interior. July 7, 2004.

*Federal Register* (70 FR 943) 2005. *40 CFR Part 81: Air Quality Designations and Classifications for the Fine Particles (PM<sub>2.5</sub>) National Ambient Air Quality Standards*. U.S. Environmental Protection Agency. January 5, 2005.

- FFWCC 2004. Florida Fish and Wildlife Conservation Commission. *Florida's Endangered Species, Threatened Species, And Species Of Special Concern*. State of Florida. January 29, 2004. Available at <http://www.floridaconservation.org/>.
- FWS 2003. U.S. Fish and Wildlife Service. *Species Information. Threatened and Endangered Animals and Plants*. Available at <http://endangered.fws.gov/wildlife.html>. 2003.
- HHS 2001. U.S. Department of Health and Human Services. *Deaths: Preliminary Data for 2000*. National Vital Statistics Reports, Volume 49, Number 12. Available at <http://www.cdc.gov/nchs>. October 9, 2001.
- HNUS 1992. Halliburton NUS Environmental Corporation. *World Demographic Update Through 1990 for Space Nuclear System Analyses*. June 12, 1992.
- IAEA 1976. International Atomic Energy Agency. *Transuranium Nuclides in the Environment*. Report Number STI/PUB/410. Vienna, Austria. 1976.
- ICRP 1990. International Commission on Radiological Protection. *1990 Recommendations of the International Commission on Radiological Protection*. ICRP-60. Volume 27. 1990.
- Jackman et al. 1998. Jackman, C.H., D.B. Considine, and E.L. Fleming. *A Global Modeling Study of Solid Rocket Aluminum Oxide Emission Effects on Stratospheric Ozone*. Geophys. Res. Lett., 25, 907-910. March 15, 1998.
- Jackman 1998. Personal Communication from C. Jackman, National Aeronautics and Space Administration, to J. Smith, Jet Propulsion Laboratory. Regarding current information on ozone depletion from launch vehicle emissions. March 18, 1998.
- LMILS 2001. International Launch Services. *Atlas V Launch System Mission Planner's Guide*. Revision 9. Available at <http://www.ilslaunch.com/missionplanner/>. September 2001.
- LMMS 1997. Lockheed Martin Missiles and Space, Valley Forge Operations. *GPHS-RTGs in Support of the Cassini Mission, Final Safety Report*. CRDL C.3. Philadelphia, PA. May 30, 1997.
- Millis 2003. Personal Communication from R.L. Millis, Lowell Observatory, to D. Bogan, NASA Headquarters. Regarding the number of known Kuiper Belt Objects. December 16, 2003.
- NASA 1989. National Aeronautics and Space Administration. *Final Environmental Impact Statement for the Galileo Mission (Tier 2)*. Solar System Exploration Division, Office of Space Science and Applications, NASA Headquarters. Washington, D.C. May 1989.
- NASA 1990. National Aeronautics and Space Administration. *Final Environmental Impact Statement for the Ulysses Mission (Tier 2)*. Solar System Exploration Division, Office of Space Science and Applications, NASA Headquarters. Washington, D.C. June 1990.

- NASA 1995a. National Aeronautics and Space Administration. *Final Environmental Impact Statement for the Cassini Mission*. Solar System Exploration Division, Office of Space Science, NASA Headquarters, Washington, D.C. June 1995.
- NASA 1995b. National Aeronautics and Space Administration. *Mars Global Surveyor Mission Environmental Assessment*. Solar System Exploration Division, Office of Space Science, NASA Headquarters, Washington, DC. September 1995.
- NASA 1997. National Aeronautics and Space Administration. *Final Supplemental Environmental Impact Statement for the Cassini Mission*. Mission and Payload Development Division, Office of Space Science, NASA Headquarters. Washington, D.C. June 1997.
- NASA 2001. National Aeronautics and Space Administration. *KSC Ionizing Radiation Protection Program*. KHB 1860.1. Kennedy Space Center, Florida. August 2001.
- NASA 2002. National Aeronautics and Space Administration. *Final Environmental Assessment for Launch of NASA Routine Payloads on Expendable Launch Vehicles from Cape Canaveral Air Force Station, Florida and Vandenberg Air Force Base, California*. Office of Space Science, NASA Headquarters, Washington, D.C. June 2002.
- NASA 2003. National Aeronautics and Space Administration. *Environmental Resources Document, Kennedy Space Center*. KSC-DF-3080, Rev. D. Kennedy Space Center, Florida. August 2003.
- NCRP 1987. National Council on Radiation Protection and Measurements. *Ionizing Radiation Exposure of the Population of the United States*. NCRP Report 93. September 1, 1987.
- NOAA 1980. National Oceanic and Atmospheric Administration. *Delta Atlas—Eastern United States Coastal and Ocean Zones*. Washington, D.C. August 1980.
- NOAA 2001. National Oceanic and Atmospheric Administration. *Summary of Natural Hazard Statistics for 2000 in the United States*. August 16, 2001.
- NRC 1986, U.S. Nuclear Regulatory Commission. *Safety Goals for the Operation of Nuclear Power Plants, Policy Statement*. Federal Register, Vol. 51, No. 149, p. 30028. August 21, 1986.
- NRC 1987. U.S. Nuclear Regulatory Commission. *Report on the Accident at the Chernobyl Nuclear Power Station*. NUREG-1250. January 1987.
- NRC 1990. National Research Council. *Health Effects of Exposure to Low Levels of Ionizing Radiation*. Committee on the Biological Effects of Ionizing Radiation (BEIR V), Board on Radiation Effects Research, Commission on Life Sciences. National Academy Press. Washington D.C. 1990.



- NRC 1998. National Research Council. *Exploring the Trans-Neptunian Solar System*. Committee on Planetary and Lunar Exploration, Space Studies Board. National Academy Press. Washington, D.C. 1998.
- NRC 2003. National Research Council. *New Frontiers in the Solar System, An Integrated Exploration Strategy*. Solar System Exploration Survey, Space Studies Board. National Academies Press. Washington, D.C. 2003.
- Port Canaveral 2003. *Business Matters at Port Canaveral*. Canaveral Port Authority, Cape Canaveral, Florida. Available at <http://www.portcanaveral.org/business/index.htm>. 2003.
- Schmalzer et al. 1998. Schmalzer, P.A., S.R. Boyle, P. Hall, D.M. Oddy, M.A. Hensley, E.D. Stolen, and B.W. Duncan. *Monitoring Direct Effects of Delta, Atlas, and Titan Launches from Cape Canaveral Air Station*. NASA Technical Memorandum 207912. June 1998.
- SFWMD 1995. South Florida Water Management District. 1995 Land Use / Land Cover GIS data (Version 1.0). West Palm Beach, FL. 1995.
- SJRWMD 1998. St Johns River Water Management District. GIS Export Data Library, Version 2.0. Available at <http://sjr.state.fl.us/explib/disk1/docs/index.html>. August 1998.
- UNSCEAR 1988. United Nations Scientific Committee on the Effects of Atomic Radiation. *Sources, Effects, and Risks of Ionizing Radiation*. UN Report E.88.IX.7. 1988.
- USAF 1996. U.S. Air Force. *Final Environmental Assessment for the Delta III Launch Vehicle Program, Cape Canaveral Air Station*. Prepared by McDonnell Douglas Aerospace Space and Defense Systems. April 1996.
- USAF 1998. U.S. Air Force. *Final Environmental Impact Statement – Evolved Expendable Launch Vehicle Program*. HQ USAF/ILEVP, 1260 Air Force Pentagon, Washington, D.C. April 1998.
- USAF 1999. U.S. Air Force. *Nuclear Safety Review and Launch Approval for Space or Missile Use of Radioactive Material and Nuclear Systems*. Air Force Instruction 91-110, March 18, 1994; 30<sup>th</sup> Space Wing, Supplement 1, January 18, 1999.
- USAF 2000. U.S. Air Force. *Final Supplemental Environmental Impact Statement (SEIS) for the Evolved Expendable Launch Vehicle Program*, HQ USAF/ILEVQ, 1260 Air Force Pentagon, Washington, D.C. March 2000.
- USAF 2001. U.S. Air Force. *Integrated Natural Resource Management Plan*. 45<sup>th</sup> Space Wing, Patrick Air Force Base, Florida. 2001.
- USAF 2004. U.S. Air Force. *Range Safety User Requirements Manual*. Air Force Space Command Manual 91-710. July 1, 2004. Available at <http://www.e-publishing.af.mil/>.

USBC 2000. U.S. Bureau of the Census. *Total United States Population for 2000*. Available at <http://factfinder.census.gov>. 2000.

USBC 2001. U.S. Bureau of the Census. *Census 2000 Data for the State of Florida*. Available at [http://www.census.gov/Press-Release/www/2001/tables/redist\\_fl.html](http://www.census.gov/Press-Release/www/2001/tables/redist_fl.html). 2001.