

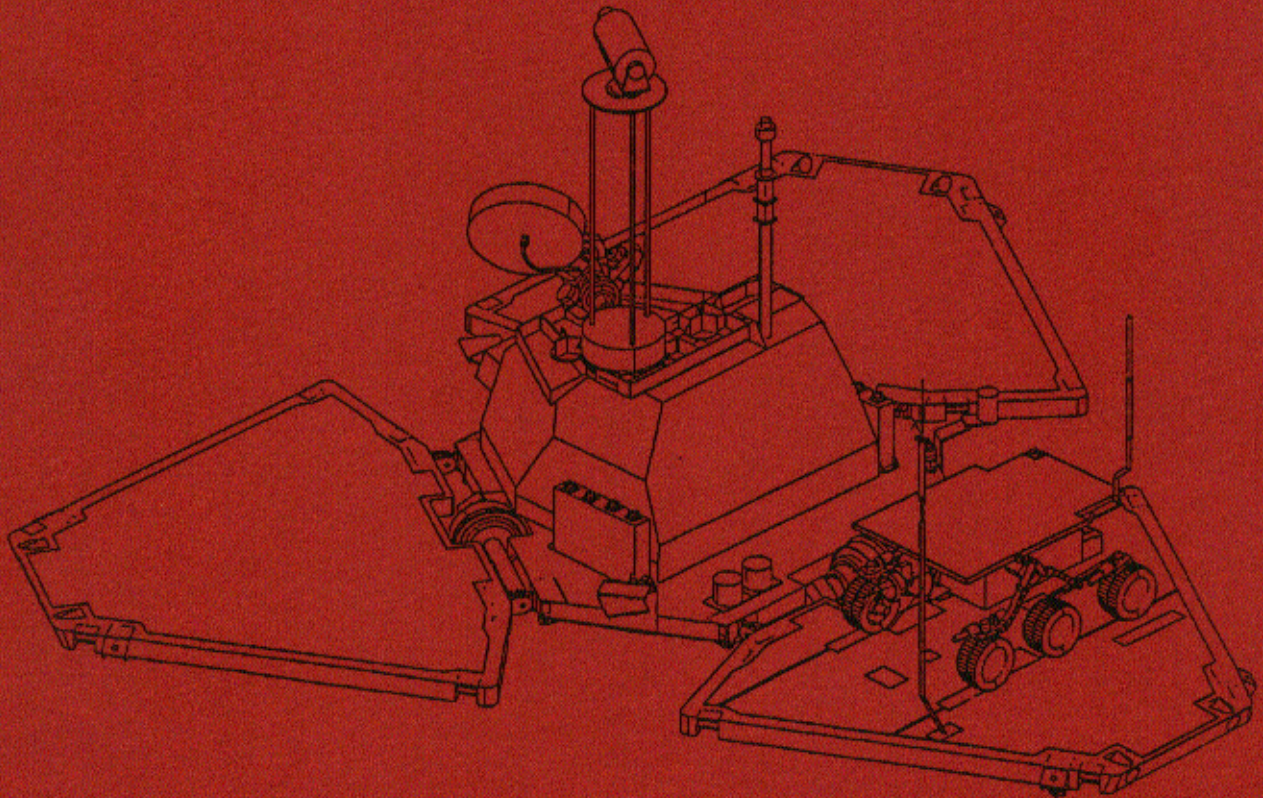

National Aeronautics and
Space Administration

Mars Pathfinder Mission Environmental Assessment



July 1994

Prepared for and in cooperation with:

National Aeronautics and Space Administration
Office of Space Science
Solar System Exploration Division
Washington, DC 20546-0001

PME
4010
P27

PL

Division Laboratory
Institute of Technology

94

ID : 2086

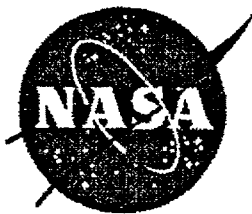

National Aeronautics and
Space Administration

Mars Pathfinder Mission Environmental Assessment

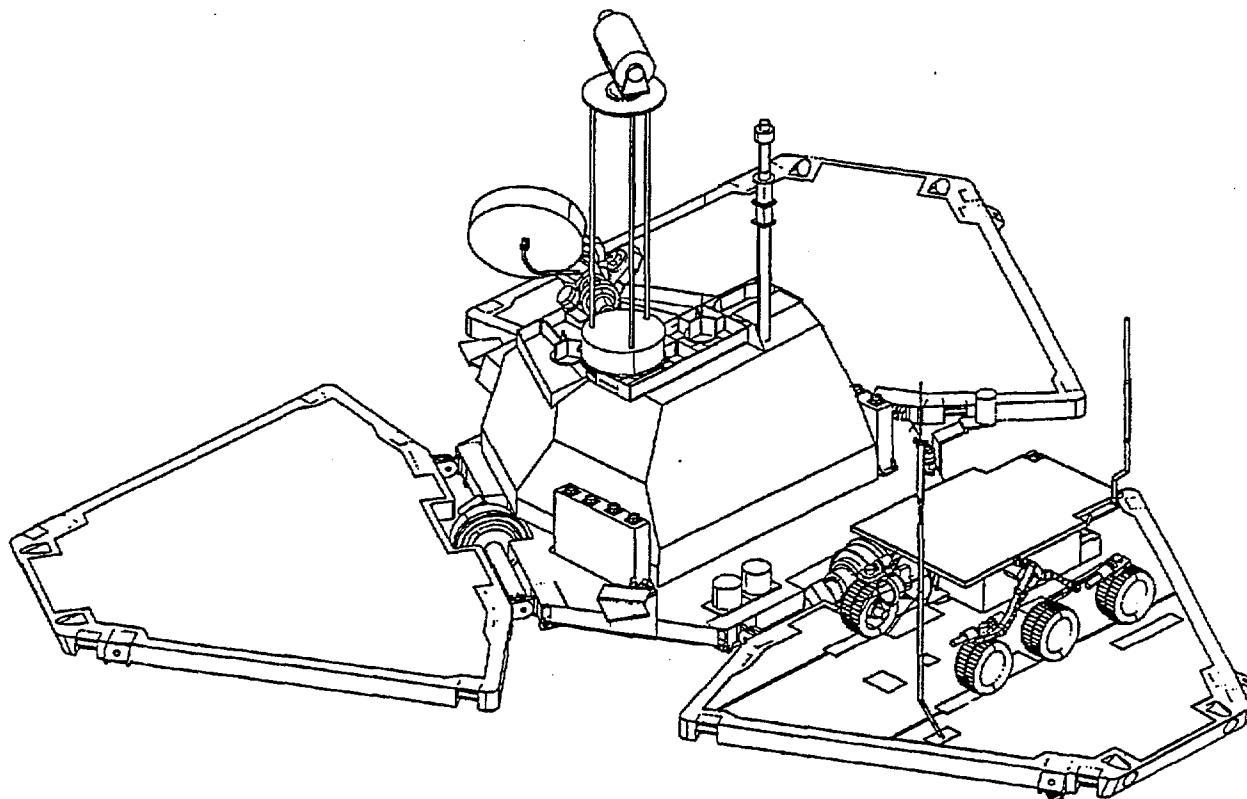

July 1994

Prepared for and in cooperation with:

National Aeronautics and Space Administration
Office of Space Science
Solar System Exploration Division
Washington, DC 20546-0001

JPL

Jet Propulsion Laboratory
California Institute of Technology
JPL D-10994

TABLE OF CONTENTS

ACRONYMS AND ABBREVIATIONS		xi
EXECUTIVE SUMMARY.....		ES-1
1	PURPOSE AND NEED	1-1
	1.1 PURPOSE OF THE PROPOSED ACTION	1-1
	1.2 NEED FOR THE PROPOSED ACTION	1-3
2	PROPOSED ACTION AND ALTERNATIVES	2-1
	2.1 PROPOSED ACTION	2-1
	2.1.1 Pathfinder Mission Description	2-1
	2.1.1.1 General.....	2-1
	2.1.1.2 Pathfinder Entry, Descent, and Landing Approach.....	2-1
	2.1.2 Pathfinder Science Objectives	2-4
	2.1.2.1 Obtain Data on the Structure of the Martian Atmosphere Along the Entry and Descent Trajectory	2-4
	2.1.2.2 Characterize the Landing Site Surface Morphology and Geology at Sub-Meter Scale	2-4
	2.1.2.3 Monitor Meteorological and Atmospheric Conditions at the Landing Site.....	2-4
	2.1.2.4 Investigate the Mineralogy and Elemental Composition of Rocks, Soil, and Surface Material	2-5
	2.1.3 Pathfinder Engineering Objectives	2-5
	2.1.3.1 Interplanetary Cruise and Entry, Descent, and Landing System	2-5
	2.1.3.2 Monitor and Evaluate Lander Performance in the Martian Environment	2-5
	2.1.3.3 Provide Systems Inheritance for Future Lander Missions	2-6
	2.1.3.4 Demonstrate the Use of a Rover Surface Vehicle for Instrument Deployment and Operation	2-6
	2.1.4 Spacecraft Description	2-6
	2.1.4.1 General	2-6
	2.1.4.2 Cruise Stage	2-6
	2.1.4.3 Deceleration Subsystems	2-6
	2.1.4.4 Lander	2-9
	2.1.4.5 Spacecraft Pyrotechnic Devices	2-9
	2.1.4.6 Science and Engineering Instrumentation	2-10

2.1.5	Rover	2-12
2.1.5.1	General	2-12
2.1.5.2	Rover Instrumentation	2-12
2.1.5.3	Rover Power Subsystem	2-13
2.1.5.4	Rover Thermal Control	2-14
2.1.6	Launch Vehicle	2-16
2.1.6.1	Payload Fairing	2-16
2.1.6.2	Delta II First and Second Stage	2-16
2.1.6.3	PAM-D Upper Stage	2-16
2.1.6.4	Flight Termination System	2-18
2.1.6.5	Launch Vehicle Debris	2-19
2.1.7	Cape Canaveral Air Force Station Operations	2-19
2.1.7.1	Launch Vehicle Processing	2-20
2.1.7.2	Spacecraft Processing	2-20
2.2	ALTERNATIVES TO THE PROPOSED ACTION	2-23
2.2.1	Reduce or Eliminate the Plutonium Heat Sources	2-23
2.2.1.1	Insulating the Warm Electronics Box Thermal Enclosure	2-23
2.2.1.2	Operating Electric Heaters Using the Rover Batteries.....	2-24
2.2.1.3	Operating Electric Heaters Via a Lander Power Umbilical	2-25
2.2.1.4	Summary	2-26
2.2.2	Alternative Launch Systems	2-26
2.2.2.1	Selection Criteria	2-26
2.2.2.2	Foreign Launch Vehicles	2-26
2.2.2.3	U.S. Launch Vehicles	2-27
2.2.2.4	Summary	2-27
2.2.3	No-Action Alternative	2-28
3	GENERAL ENVIRONMENTAL CHARACTERISTICS OF CAPE CANAVERAL AIR FORCE STATION AND SURROUNDING AREA	3-1
3.1	REGIONAL AND LOCAL ENVIRONMENT	3-1
3.1.1	Population Distribution	3-1
3.1.2	Land Use	3-4
3.1.3	Economic Base	3-6
3.1.4	Public Facilities and Emergency Services	3-7
3.1.5	CCAFS Facilities and Services	3-8
3.1.6	Archeological and Cultural Resources	3-8

3.2	NATURAL ENVIRONMENT	3-9
3.2.1	Meteorology and Air Quality	3-9
3.2.1.1	Meteorology	3-9
3.2.1.2	Air Quality	3-11
3.2.2	Noise	3-11
3.2.3	Land Resources	3-13
3.2.3.1	Geology	3-13
3.2.3.2	Soils	3-13
3.2.4	Hydrology and Water Quality	3-14
3.2.4.1	Surface Waters	3-14
3.2.4.2	Surface Water Quality	3-14
3.2.4.3	Ground Waters	3-15
3.2.4.4	Ground Water Quality	3-16
3.2.5	Biotic Resources	3-16
3.2.5.1	Terrestrial Biota	3-18
3.2.5.2	Aquatic Biota	3-19
3.2.5.3	Threatened and Endangered Species	3-19
4	ENVIRONMENTAL IMPACTS OF PROPOSED ACTION AND ALTERNATIVES	4-1
4.1	ENVIRONMENTAL IMPACTS OF A NORMAL LAUNCH	4-1
4.1.1	Air Quality	4-1
4.1.2	Land Resources	4-7
4.1.3	Local Hydrology and Water Quality	4-7
4.1.4	Ocean Environment	4-8
4.1.5	Biotic Resources	4-8
4.1.6	Threatened and Endangered Species	4-8
4.1.7	Developed Environment	4-9
4.2	ACCIDENTS AND LAUNCH FAILURES	4-10
4.2.1	Liquid Propellant Spill	4-10
4.2.2	Launch Failures	4-10
4.2.2.1	Non-Radiological Impacts	4-10
4.2.2.2	Radiological Impacts	4-12
5	REGULATORY REVIEW	5-1
5.1	AIR QUALITY	5-1
5.2	WATER QUALITY	5-1
5.2.1	Stormwater Discharge	5-1
5.2.2	Sanitary and Industrial Wastewater Discharge	5-1
5.2.3	Floodplains and Wetlands	5-2
5.3	HAZARDOUS WASTES	5-2

5.4	SPILL PREVENTION	5-2
5.5	COASTAL MANAGEMENT PROGRAM	5-2
5.6	ARCHAEOLOGICAL AND CULTURAL RESOURCES	5-3
5.7	CORRESPONDENCE WITH FEDERAL AGENCIES	5-3
	5.7.1 United States Environmental Protection Agency	5-3
5.8	CORRESPONDENCE WITH STATE AGENCIES	5-3
	5.8.1 Florida State Clearinghouse.....	5-3
6	REFERENCES	6-1

APPENDICES

A CORRESPONDENCE WITH STATE AND FEDERAL AGENCIES

FIGURES

2-1	Mars Pathfinder Trajectory	2-2
2-2	Mars Pathfinder Entry, Descent, and Landing (EDL) Sequence	2-3
2-3	Pathfinder Flight System	2-7
2-4	Mars Pathfinder Cruise Stage	2-8
2-5	Pathfinder Lander Deployed Configuration	2-10
2-6	Pathfinder Rover	2-13
2-7	Light Weight Radioisotope Heater Unit (LWRHU)	2-15
2-8	Pathfinder Orientation in the Delta II 7925 Payload Fairing	2-15
2-9	Delta II 7925 Launch Configuration	2-17
2-10	Payload Assist Module-Delta (PAM-D) Upper Stage	2-18
2-11	Launch Vehicle and Spacecraft Processing Areas, KSC/CCAFS	2-21
2-12	Mean WEB Equipment Temperature Profile with Differing Numbers of LWRHUs	2-25
3-1	Regional Area of Interest	3-2
3-2	Location of CCAFS Relative to the Region of Interest	3-3
3-3	Land Use at CCAFS	3-5
3-4	Launch Complex 17	3-7
3-5	Wind Roses Indicating Seasonal Wind Directions — Lower Atmospheric Conditions: Cape Canaveral/Merritt Island Land Mass	3-10
4-1	Delta II 7925 Launch Area Flight Profile	4-4
4-2	Delta II 7925 Boost Profile (Up to Orbit Injection)	4-5

TABLES

2-1	Pathfinder Rover Experiments	2-12
3-1	State and Federal Air Quality Standards	3-12
3-2	Launch Noise Levels at Kennedy Space Center	3-13
3-3	Summary of Water Quality Monitoring Data for South Banana River	3-15
3-4	Ground Water Quality for the Floridan Aquifer at CCAFS	3-17
3-5	Listed and Proposed Threatened and Endangered Animal Species and Candidate Animal Species in Brevard County and Their Status On CCAFS	3-20
4-1	Combustion Products for the GEM Solid Rocket	4-2
4-2	Exhaust Products for the Delta II First Stage (Modified RS-27A)	4-2
4-3	Combustion Products for Delta II 7925 GEM Failure Scenario	4-11
4-4	Combustion Products for Delta II 7925 Catastrophic Failure Scenario	4-11
4-5	Accident Scenarios Considered In the Safety Assessment	4-13

ACRONYMS AND ABBREVIATIONS

AIMS	Attitude and Information Management Subsystem
AL ₂ O ₃	Aluminum Oxide
APXS	Alpha Proton X-Ray Spectrometer
ARAR	Accident Risk Assessment Report
ASI	Atmospheric Structure Instrument
CCAS	Cape Canaveral Air Station
CCD	Charge Coupled Device
CDR	Command Destruct Receiver
CDU	Command Detection Unit
CEQ	Council on Environmental Quality
Ci	Curie
CO	Carbon Monoxide
Cm-244	Curium-244
DOE	Department of Energy
DMCO	Delta Mission Checkout
DSN	Deep Space Network
EA	Environmental Assessment
ER	Eastern Range
FCREPA	Florida Commission on Rare and Endangered Plants and Animals
FDER	Florida Department of Environmental Regulation
FGFWFC	Florida Game and Fresh Water Fish Commission
fps	feet per second
FTS	Flight Termination System
FWS	U.S. Fish and Wildlife Service
GaAs	Gallium-Arsenide
GBq	Gigabequerel (10 ⁹ disintegrations per second)
GEM	Graphite Epoxy Motor
HCl	Hydrogen Chloride
HGA	High Gain Antenna
HPF	Hazardous Processing Facility
IELV	Intermediate Expendable Launch Vehicle
IMP	Imager for Mars Pathfinder
JPL	Jet Propulsion Laboratory
KSC	Kennedy Space Center
LC-17	Launch Complex 17, CCAS
LEO	Low Earth Orbit
LGA	Low Gain Antenna
LiSOCl ₂	Lithium Thionyl Chloride
LWRHU	Light Weight Radioisotope Heater Unit
MAC	Maximum Allowable Concentration
MLV	Medium Launch Vehicle

$\mu\text{g}/\text{m}^3$	micrograms per cubic meter
m/s	meters per second
mph	miles per hour
MSPSP	Missile System Pre-Launch Safety Plan
N	Newton
N_2H_4	Hydrazine
NAAQS	National Ambient Air Quality Standard
NAS	National Academy of Sciences
NASA	National Aeronautics and Space Administration
NEPA	National Environmental Policy Act
NHL	National Historic Landmark
NOx	Nitrogen Oxides (generic)
NCS	Nutation Control System
NSI	NASA Standard Initiator
OFW	Outstanding Florida Water
PAM -D	Payload Assist Module-Delta
PLF	Payload Fairing
ppm	parts per million
RAD	Rocket Assisted Deceleration
S&A	Safe and Arm
SCS	Soil Conservation Service (of the U.S. Department of Agriculture)
SNC	Shergotty, Nakhla, and Chassigny (Meteorites)
SRM	Solid Rocket Motor
SSE	Solar System Exploration
TBq	Terabequerel (10^{12} disintegrations per second)
TCU	Telemetry Control Unit
TEL	Telecommunications Subsystem
TMU	Telemetry Modulation Unit
WEB	Warm Electronics Box

EXECUTIVE SUMMARY

PROPOSED ACTION

This Environmental Assessment (EA) addresses the proposed action to assemble, integrate, and launch the Mars Pathfinder spacecraft from Cape Canaveral Air Station (CCAS), Florida, in December 1996. The spacecraft and its upper stage would be assembled and integrated in facilities at the Kennedy Space Center (KSC) and CCAS, then transferred to Launch Complex 17 (LC-17) on CCAS.

The baseline launch vehicle, a Delta II 7925, would be assembled in facilities at CCAS before being transferred to LC-17. The Delta II 7925 consists of a liquid bipropellant main engine, a liquid bipropellant second stage engine, and nine graphite epoxy motor (GEM) strap-on solid rockets. While most of the checkout of the spacecraft and launch vehicle would be performed at individual integration buildings, operations completed at the launch site would include mating of the spacecraft and upper stage with the launch vehicle, integrated systems tests and checkout, liquid propellant servicing, and ordnance installation.

PURPOSE AND NEED FOR THE ACTION

The Mars Pathfinder mission would be one of the first of NASA's low-cost (\$150M [FY '92] dollars) Discovery Class missions, rapid development programs with highly focused planetary science objectives. The purpose of the Pathfinder mission is the landing of a single vehicle on Mars in 1997 to demonstrate enabling systems, technologies, and management approaches for delivering small science payloads to Mars. To satisfy this purpose, the Pathfinder mission supports both engineering and scientific sets of objectives.

Although significant insights into the evolution of Mars have resulted from previous explorations, large gaps in knowledge about Mars remain. Detailed, in-situ data from multiple sites on the martian surface is needed to help answer some of the questions about the history and current state of water on Mars, the evolution of the planet's atmosphere, and the factors that led to major changes in the martian climate. Such an investigation would also help scientists to understand more about the evolution and present state of the solar system. The Mars Pathfinder mission would provide some of the answers to these questions, as well as provide a demonstration of the technological approaches that could be applicable to future Mars missions.

MISSION DESCRIPTION

Mars Pathfinder would deliver a landing craft (hereinafter "Lander") carrying a small Rover vehicle (63 cm long by 48 cm wide, or about 25 by 19 inches) to the surface of Mars' northern hemisphere in July 1997. The Lander would enter the martian atmosphere and descend to the surface using an aeroshell, parachute, and solid fuel rockets to slow the descent. An airbag system would soften the final landing shock. The Lander would transmit engineering and science data collected during entry and descent. The microrover would then be deployed to the surface from the Lander. The Lander would serve as a telemetry relay for the microrover to receive commands from, and return data to, controllers on Earth. Traversing martian terrain, the Rover would conduct microrover technology experiments such as UHF link effectiveness and vision sensor performance, and provide performance data on capabilities such as wheel/soil interactions and hazard detection. The Rover would also train its imaging system on the Lander to allow assessment of the Lander's condition and gather science data on the rocks and soil at selected sites. The primary Lander mission would last 30 days. The primary mission for the Rover would have a duration of about seven days.

Rover electronics are qualified for operation at temperatures above -40°C (-40°F), and are qualified to survive temperatures as low as -55°C (-67°F). These temperature-sensitive elements (electronics and batteries) would be enclosed in a thermally insulated box. Based upon what is known at this time concerning martian surface temperatures and thermal analyses performed for the insulated box, insulation will not be sufficient to prevent the nighttime temperature inside the insulated box dropping below -60°C (-76°F), making it unlikely that the Rover could operate past a single martian night. Therefore, the baseline Rover design could include up to three Lightweight Radioisotope Heater Units (LWRHUs) as an additional heat source for the insulated box. The LWRHU is a small, passive heat source that emits heat from the natural radioactive decay of plutonium-238. The units are designed to provide heat safely and reliably to Rover electronics. Each unit contains roughly 2.7 g (about 0.1 oz) of plutonium dioxide as a heat source in a single pellet and produces approximately 1 thermal watt. The pellet is surrounded by a platinum-rhodium alloy clad, insulation systems of pyrolytic graphite, a helium gas vent, and a graphite aeroshell/impact body of fine-weave, pierced fabric (DOE 1988). Use of the LWRHUs would ensure that the sensitive Rover electronic components are kept at a temperature above -30° (-22°F).

ALTERNATIVES CONSIDERED

Alternatives to the proposed action that were considered included those that: (1) reduce or eliminate the plutonium heat sources needed for Rover thermal

control, (2) utilize an alternate launch vehicle/upper stage combination, or (3) eliminate the Pathfinder mission (the No-Action alternative).

Reduce or Eliminate the Plutonium Heat Sources

Martian nighttime temperatures could drop as low as -100°C (-148°F). The proposed Rover design calls for LWRHUs to augment the solar-panel heating to maintain the electronics and batteries at operable temperatures during martian nights. To maintain a favorable thermal environment for the electronics and batteries without the use of plutonium heat sources, either additional insulation must be added to the thermal enclosure or additional heat must be provided from an electrical power source.

- Insulating the Warm Electronics Box (WEB) Thermal Enclosure

To accomplish the objectives of the Pathfinder mission within the cost constraints levied on the mission, both the Lander and the Rover are subject to stringent mass and volume limitations. Additionally, many of the commercial parts planned for use on the Rover are subject to failure if cycled several times below their qualified minimum operating temperatures. If LWRHUs are not used to augment WEB heating, this cycling would be unavoidable. The combination of potentially shorter component lifetimes and the life requirements of the mission increases the risk that Pathfinder's minimum objectives could not be met.

- Operating Electric Heaters Using the Rover Batteries

Powering electric heaters at night with the Rover batteries would not be feasible, since the batteries are not rechargeable (rechargeable batteries could not be used due to mass constraints) and their energy likely would be consumed after one night on the martian surface, ending Rover operations prior to the completion of its primary mission and precluding use of the APXS.

- Operating Electric Heaters Via a Lander Power Umbilical

While electric heaters could be operated via a power umbilical from the Lander to the Rover, such an arrangement would tether the Rover and restrict its surface exploration to only a short distance from the Lander. In addition to reducing the area it could travel, a tether would vastly complicate Rover operations by introducing the threat of entanglement. The complexities of this approach would seriously jeopardize Rover science instrument data collection and analyses of martian surface composition and would negate technology demonstrations of autonomous surface navigation, one of the primary objectives of the Rover mission.

Alternate Launch Vehicles

The most desirable launch vehicle for Mars Pathfinder would meet but not greatly exceed the mission's minimum launch performance requirements. Other considerations in the selection of a launch vehicle include reliability, cost, and potential environmental impacts associated with the use of the vehicle. Of the several alternative U.S. and foreign launch vehicles considered, the Delta II 7925 most closely matches the Pathfinder's mission requirements:

- The mass performance of the Delta II 7925/PAM-D most closely matches the Pathfinder performance requirement.
- The Delta II 7925/PAM-D is the more reliable alternative launch system of those systems meeting the Pathfinder performance criteria.
- The Delta II 7925/PAM-D is the lower cost alternative launch system of those systems meeting the performance criteria.
- Of the reasonable alternative launch systems examined, all were approximately equal in their potential environmental impacts.

No-Action Alternative

The No-Action alternative would mean the Mars Pathfinder mission would not be undertaken.

The small environmental impacts associated with the proposed mission would be eliminated. Impacts of the No-Action alternative would include disrupting the progress of NASA's inner solar system exploration program. For Mars, the program calls for progressively more detailed reconnaissance by spacecraft and robotic explorers. The No-Action alternative would delay or prevent development and demonstration of technologies critical to future explorations of Mars and which have wide applicability in a variety of research and industrial enterprises on Earth.

SUMMARY OF ENVIRONMENTAL IMPACTS

The only expected environmental effects of the proposed action are associated with normal launch vehicle operation and are summarized below.

Air Quality

In a normal launch, exhaust products from a Delta II launch are distributed along the launch vehicle's path. The quantities of exhaust are greatest at ground level and decrease continuously. The portion of the exhaust plume that persists longer than a few minutes (the ground cloud) is emitted during the first few seconds of flight and is concentrated near the pad area. The ground cloud resulting from a normal Delta II launch is predicted to have a radius of 20.3 meters (about 67 feet).

Hydrogen chloride (HCl) concentrations in the Delta II exhaust plume should not exceed 5 ppm beyond about 4.3 km (2.7 miles) in a downwind direction. The nearest uncontrolled area is about 4.8 km (3 miles) from LC-17. Appropriate safety measures will be taken to ensure that the permissible exposure limits defined by the Occupational Safety and Health Administration (5 ppm for an 8-hour time-weighted exposure limit) are not exceeded for personnel in the launch area.

To estimate the peak ground level concentrations of ground cloud pollutants, the U.S. Air Force has extrapolated Delta II exhaust plume diffusion data from models developed for the Titan launch vehicle program. These Titan models are used to calculate peak ground level concentrations of various pollutants in ground clouds. Due to the similarity in propellant types, the Delta vehicle ground cloud will be similar in composition to that produced by the Titan. However, the size of the Delta ground cloud should be considerably smaller than that of the Titan because the Delta vehicle and solid rocket GEMs contain less propellant, produce less vapor, and accelerate off the launch pad more quickly than the Titan.

Based upon these comparative studies, HCl concentrations are not expected to be high enough to be harmful to the general population. Although National Ambient Air Quality Standards (NAAQS) have not been adopted for HCl, the National Academy of Sciences (NAS) developed recommended limits for short-term exposure to HCl, ranging from 20 ppm for a 60-minute exposure to 100 ppm for a 10-minute exposure. Since the nearest uncontrolled area (i.e., general public) is approximately 4.8 km (3 miles) from LC-17, HCl concentrations are not expected to be high enough to be harmful to the general population. The maximum level of HCl expected to reach uncontrolled areas during preparation and launch of the Delta II would be well below the NAS recommended limits.

The same predictive modeling techniques used for HCl were also applied to CO and Al₂O₃. Carbon monoxide concentrations are not expected to exceed the NAAQS of 35 ppm (1 hr average) beyond the immediate vicinity of the launch complex and are expected to rapidly oxidize to carbon dioxide (CO₂) in the atmosphere. For Titan launches, CO concentrations were predicted to be less than 9 ppm except for brief periods during actual lift-off. Concentrations resulting from a Delta launch should be considerably lower.

Aluminum Oxide (Al₂O₃) typically exists as a crystalline dust in solid rocket motor (SRM) exhaust clouds, but is quite inert chemically and is not toxic. The NAAQS for continuous emitters of particulate matter, 150 µg/m³ (24-hour average), should not be exceeded by a Delta II launch due to the short nature of the launch event.

Nitrogen oxides may enter the atmosphere through propellant system venting, but air emission control devices will be used to mitigate this small and infrequent pollutant source. First stage propellants will be carefully loaded using a system with redundant spill-prevention safeguards, and vapors from fueling will be treated, then disposed by a certified hazardous waste contractor.

Space vehicles that use SRMs have been studied concerning potential contribution to ozone depletion because of their exhaust products, with the primary depleting component being HCl [USAF 1990]. Extrapolating from estimates made for the Titan IV solid rocket motor upgrade (SRMU) effects on ozone, it is safe to say that the effect on ozone from a Delta II launch would be negligible and indistinguishable from effects caused by other natural and human-made causes.

Since the ground cloud for a Delta II launch is very small (about 20.3 m or 67 ft) and concentrates around the launch pad there should be no substantial acid rain beyond the near-pad area.

Land Resources

Overall, launching a Delta II vehicle would not be expected to have significant negative effects on the land forms surrounding Launch Complex 17. However, launch activities could have some small impacts near the launch pad associated with fire and acidic depositions. Minor brush fires are infrequent by-products of Delta launches, and are contained and limited to the ruderal vegetation within the launch complexes; past singeing has not permanently affected the vegetation near the pads. Wet deposition of hydrogen chloride (HCl) could damage or kill vegetation, but would not be expected to occur outside the pad fence perimeter.

Local Hydrology and Water Quality

Water at LC-17 would be used for deluge, launch pad washdown and fire suppressant, and potable water. It would be supplied by municipal sources and would not require the withdrawal of ground water. Most of the deluge, washdown, and fire suppressant water will be collected in a concrete catchment basin, and any propellant release would occur within sealed trenches and should not contaminate runoff. If the catchment basin water meets federal discharge criteria, it would be discharged directly to grade at the launch site. If it fails to meet the criteria, it would be treated on site and disposed to grade or collected and disposed of by a certified contractor.

The primary surface water impacts from a normal Delta II launch involve HCl and Al₂O₃ deposition from the exhaust plume. The cloud will not persist or remain over any location for more than a few minutes. Depending on wind direction, most of the exhaust may drift over the Banana River or the Atlantic Ocean. A brief acidification of surface waters may result from HCl deposition. A normal Delta II launch will have no significant impacts to the local water quality.

Ocean Environment

In a normal launch, the first and second stages and the SRMs would impact the ocean. The trajectories of spent stages and SRMs would be programmed to impact a safe distance from any U.S. coastal area or other land mass. Toxic concentrations of metals would not be likely to occur due to the slow rate of corrosion in the deep ocean environment and the large quantity of water available for dilution.

Along with the spent stages would be relatively small amounts of propellant. Concentrations in excess of the maximum allowable concentration of these compounds for marine organisms would be limited to the immediate vicinity of the spent stage. No substantial impacts would be expected from the reentry and ocean impact of spent stages, due to the small amount of residual propellants and the large volume of water available for dilution.

Biotic Resources

A normal Delta II launch would not be expected to substantially impact CCAS terrestrial, wetland, or aquatic biota. The elevated noise levels of launch are of short duration and will not substantially affect wildlife populations. Wildlife encountering the launch-generated ground cloud could experience brief exposure to exhaust particles, but would not experience any substantial impacts. Aquatic biota could experience acidified precipitation, if the launch were to occur during a rain shower. This impact would be

expected to be insignificant due to the brevity of the small ground cloud and the high buffering ability of the surrounding surface waters to rapidly neutralize excess acidity.

Threatened and Endangered Species

Any action that may affect Federally listed species or their critical habitats requires consultation with the U.S. Federal Wildlife Service under Section 7 of the Endangered Species Act of 1973 (as amended). The U.S. FWS has reviewed those actions which would be associated with a Delta II launch from LC-17 and has determined that those actions would have no effect on state or Federally listed threatened (or proposed for listing as threatened) or endangered species residing on CCAS and adjoining waters or critical habitats.

Population and Socioeconomics

The Pathfinder mission would create negligible impact on local communities, since no additional permanent personnel would be expected beyond the current CCAS staff. Launch Complex 17 has been used exclusively for space launches since the late 1950s. The Pathfinder mission would cause no additional adverse impacts on community facilities, services, or existing land uses.

Safety and Noise Pollution

Normal operations at the CCAS includes preventative health measures for workers such as hearing protection, respiratory protection and exclusion zones to minimize or prevent exposure to harmful noise levels or hazardous areas or materials.

The engine noise and sonic booms from a Delta II launch are typical of routine CCAS operations. In the history of USAF space-launch vehicle operations at CCAS, there have been no problems reported as a result of sonic booms. To the surrounding community, the noise from this activity appears, at worst, to be an infrequent nuisance rather than a health hazard.

Archeological and Cultural Resources

Since no surface or subsurface areas would be disturbed, no archeological, historic, or cultural sites would be expected to be affected by launching the Pathfinder mission.

POTENTIAL LAUNCH ACCIDENTS

Liquid Propellant Spill

The potential for an accidental release of liquid propellants will be minimized by strict adherence to established safety procedures. Post-fueling spills from the launch vehicle will be channeled into a sealed concrete catchment basin and disposed of according to the appropriate state and federal regulations.

The most severe propellant spill accident scenario would be releasing the entire launch vehicle load of N_2O_4 at the launch pad while conducting propellant transfer operations. This scenario would have the greatest potential impact on local air quality. Airborne NO_x levels from this scenario are expected to be reduced to 5 ppm within about 150 m (about 500 feet) and to 1 ppm within 300 m (about 1,000 feet). Activating the launch pad water deluge system would substantially reduce the evaporation rate, limiting exposure concentrations in the vicinity of the spill that are above federally established standards. Propellant transfer personnel will be outfitted with protective clothing and breathing equipment. Personnel not involved in transfer operations will be excluded from the area.

Non-Radiological Impacts

In the unlikely event of a launch vehicle destruction, either on the pad or in-flight, the liquid propellant tanks and SRM cases would be ruptured. Due to their hypergolic (ignite on contact) nature, a launch failure would result in a spontaneous burning of most of the liquid propellants, and a somewhat slower burning of SRM propellant fragments. Any such release of pollutants would have only a short-term impact on the environment near the pad.

Launch failure impacts on water quality would stem from unburned liquid propellant being released into CCAS surface waters. For most launch failures, propellant release into surface waters will be substantially less than the full fuel load, primarily due to the reliability of the vehicle destruct system. However, if there were an early flight termination and failure of the vehicle destruct system, it is remotely possible that the entire Stage II propellant quantity could be released to the ocean. Impacts to ocean biotic systems would be localized, transient in nature, and these systems would be expected to recover rapidly.

Radiological Impacts

- Impacts Due to LWRHUs

Based upon the Pathfinder LWRHU Safety Assessment comparisons to the tests and analytical studies performed on LWRHUs for the Galileo Mission (which had 120 LWRHUs on the orbiter and probe), no release of the plutonium heat source from the LWRHUs has been identified for any of the NASA-defined launch or reentry accident scenarios, therefore, no radiological impacts are expected as a result of using the LWRHUs.

- Impacts Due to Curium Sources on the APX Spectrometer

Due to the nature of the APXS sources, an accident which subjects the spacecraft to any of the environments defined for the LWRHUs will likely cause a release of the Curium-244 (Cm-244). However, the potential health effects associated with such a release are extremely low, largely because of the relatively small quantity of material being used (about 2.78 gigabecquerels or 75 millicuries), and the lower radiotoxicity of the material, relative to plutonium. When considered in light of the probability of a failure that could cause a release (most likely event less than 0.002), the risk of an adverse health effect due to the curium is less than 3×10^{-6} , or less than 3 in one million. Compared to a naturally occurring cancer incidence rate of about 20% (about 1 in 5) worldwide, this incremental increase in risk is negligible.

SECTION 1

PURPOSE AND NEED

The National Aeronautics and Space Administration (NASA) has prepared this Environmental Assessment (EA) for completing the preparations for the Mars Pathfinder mission, including assembly and integration of the Pathfinder spacecraft at Kennedy Space Center (KSC) and Cape Canaveral Air Station (CCAS), and its launch from Launch Complex 17 (LC-17), CCAS in December 1996 (i.e., the "proposed action"). This EA discusses the mission's objectives as well as its potential environmental impacts. Possible alternatives to the proposed action are also examined. Among the possible effects considered are air and water quality impacts, local land area impacts, adverse health and safety impacts, the disturbance of biotic resources, socioeconomic impacts, and the occurrence of adverse effects in wetland areas and areas containing historical sites. This document was completed in accordance with the National Environmental Policy Act (NEPA) of 1969, as amended (42 U.S.C. 4321, et seq.), the Council on Environmental Quality (CEQ) Regulations for Implementing the Procedural Provisions of NEPA (40 CFR parts 1500-1508), Executive Order 12114, Environmental Effects Abroad of Major Federal Actions, and the NASA policy and implementing regulations (14 CFR Part 1216).

There are distinct scientific, technological, economic, and political benefits associated with solar system exploration. The study and understanding of many significant earthly concerns (e.g., global climate change) have benefited from the techniques and theories arising from space exploration. For instance, meteorologists have been able to validate and improve their atmospheric models by testing their predictive capabilities against the real data gathered from other planets. Planetary exploration is one of the drivers of state-of-the-art technology development, such as the improved operating speed, greater reliability, and miniaturization of electronic components.

1.1 PURPOSE OF THE PROPOSED ACTION

The National Aeronautics and Space Act of 1958 (42 U.S.C. 2451(d)(5)) establishes a mandate to conduct activities in space that contribute substantially to the expansion of human knowledge, and to "the preservation of the role of the United States as a leader in aeronautical and space science and technology and in the application thereof to the conduct of peaceful activities within and outside the atmosphere." In response to this mandate, NASA, in coordination with the National Academy of Sciences, has developed a prioritized set of scientific objectives to be met through a long-range program of planetary missions (i.e., the U.S. Solar System Exploration Program). These missions are designed to be conducted in a sequence based on technological readiness, launch opportunities, timely data return, and a balanced representation of scientific disciplines.

NASA's strategy to carry out this sequence consists of an orderly progression from flyby-type reconnaissance missions, investigation with orbiters and atmospheric probes, intensive study involving landers, sample return, and human exploration. In addition, these three phases of planetary exploration are being applied to each of the three regions of the solar system: the inner solar system (terrestrial planets), the primitive bodies (comets and asteroids), and the outer solar system (the gas giants and Pluto). Emphasis in mission selection will be on continuity, commonality, and cost-effectiveness. Pathfinder is the next recommended Mars exploration mission in the inner solar system series and supports two of the Program's primary objectives: (1) understand the origin, evolution and present state of the solar system; (2) understand the Earth through comparative planetary studies.

In 1978, following the successful Viking Orbiter and Lander missions to Mars, the National Academy of Science's Committee on Planetary and Lunar Exploration identified a list of prioritized objectives for post-Viking Mars exploration. In 1983, the Solar System Exploration Committee of the NASA Advisory Council recognized that achieving the major objectives of a Mars exploration program would require establishing and operating long-lived science stations at diverse martian locations to perform seismic, meteorological, and geoscience measurements.

In November 1991, NASA directed the Jet Propulsion Laboratory (JPL) to continue study of an innovative Mars mission concept involving the establishment of numerous small science stations on the surface of Mars to collect and return scientific data. The broad science objectives of such a mission would be to characterize the martian environment in terms of atmospheric structure, global atmospheric circulation, surface morphology and geology, surface geochemistry, surface elemental composition, internal planet structure, variations in the martian gravitational field, and the planet's size and shape.

A network of science stations would provide a global sampling of the martian environment over an extended period of time, allowing observations of the martian environment that would be difficult to achieve by other methods. The *in situ* (i.e., in position or on-site) measurements would comprise a data set of "ground truth" against which the previous Viking, and future orbital, data could be compared and calibrated. The concept of using multiple landers would open the opportunity to explore some of the more scientifically interesting, but risky landing sites, such as the polar regions and those rugged, high-elevation terrains that a single-lander mission might avoid due to the increased mission risk represented by such landing sites.

The purpose of the Pathfinder mission is the landing of a single vehicle on Mars in 1997 to demonstrate enabling systems, technologies, and management approaches for delivering small science payloads to Mars. To satisfy this purpose, the Pathfinder mission supports both engineering and scientific sets of objectives. These objectives are described in Section 2 of this EA.

1.2 NEED FOR THE PROPOSED ACTION

Earth and Mars are related, inner solar system planets composed of rocky silicate material and possessing significant atmospheric cover. Mars was one of the first celestial bodies to be extensively studied by telescope; its distance from the Earth ranges from 70 to 400 million km (44 to 249 million miles). Mars has a radius of only 3,394 km (2,121 miles), compared to Earth's 6,378 km (3,964 miles), and a weaker gravitational field, only 38 percent that of Earth's.

Mars is the only other terrestrial planet known to have water. Like the Earth, Mars has polar caps composed of frozen volatiles, including water. In addition, water may be locked up as ground ice and liquid water below the surface, and adsorbed on minerals or in rocks on the surface. There is evidence for what may have been large outflow channels across the martian surface in the past, as well as small, stream-like channels in the ancient crust that are suggestive of surface runoff resulting from rain. Also within these ancient terrains is evidence for lakes or smaller standing bodies of water. Some researchers have suggested the presence of surface oceans on Mars that filled the northern lowlands of the planet, not unlike oceans on the Earth. If true, Mars had a warmer and wetter past and has undergone major climatic changes during its history. Understanding what has happened to the water on Mars and its relation to major changes in climate thus has a strong bearing on understanding major climatic fluctuations that have occurred on Earth, such as the ice ages.

Although both Mars and Earth have a long and varied history of mantle activity, Mars lacks plate tectonics, and little is known of the chemical composition of its volcanic rocks and lavas. Mars has an atmosphere, but it is thin (only 1/100 as dense as Earth's), dry, and cold (the average minimum temperature at the equator is -100°C , or about -148°F), and provides little protection from solar ultraviolet radiation, rendering the planet's surface hostile to life as we know it. Mars experiences readily measurable seasonal changes due to the 25° tilt of its axis, which is almost identical to Earth's 23.5° tilt. However, its global atmospheric dynamics, the distribution and transport of vaporized materials during the martian year, and the structure and photochemistry of the upper atmosphere are not well characterized. Even the existence and strength of an intrinsic martian magnetic field remains poorly understood.

Every object in the solar system contains part of the record of planetary origin and evolution. These geologic records are in the form of chemical and isotopic

'fingerprints', as well as in the stratigraphic sequences, structural relationships, and morphology of land forms. The unmanned exploration of Mars has reinforced the opinion that many planetary processes, including some that operate on Earth, may be universal. The geologic processes on Mars appear to have operated at a slower rate than on Earth, leaving a record of that activity preserved in the rocks on the martian surface. As a result, Mars is the only planet where such rocks, which manifest the entire history of the solar system from its origin 4.6 billion years ago to the present, are readily accessible. A detailed, first-hand investigation may help scientists understand the origin, evolution, and present state of the solar system.

Significant insights into the evolution of Mars have been gained from previous explorations, but large gaps in scientific knowledge still remain. Detailed, in-situ data from multiple sites on the martian surface is needed to help answer some of the questions about the history and current state of water on Mars, the evolution of the planet's atmosphere, and the factors that led to major changes in the martian climate. The Mars Pathfinder mission would provide some of the answers to these questions, as well as provide a demonstration of the technological approaches that could be applicable to future Mars missions.

SECTION 2 PROPOSED ACTION AND ALTERNATIVES

2.1 PROPOSED ACTION

This section describes the proposed action of making the preparations for the Mars Pathfinder mission, including integration of the Pathfinder spacecraft and its launch from Cape Canaveral Air Station (CCAS), Launch Complex 17 (LC-17), in December 1996. Alternatives to this proposed action, including the No-Action alternative, are discussed in Section 2.2.

2.1.1 Pathfinder Mission Description [JPL 1993a]

2.1.1.1 General

The Pathfinder mission involves the landing of a single vehicle on Mars to demonstrate enabling systems, technologies, and management approaches for delivering small science payloads to Mars. Current plans call for using a Delta II 7925 launch vehicle to inject the Pathfinder spacecraft into an Earth-Mars trajectory (Figure 2-1) in December 1996. The Pathfinder Lander would enter the martian atmosphere in July 1997 and descend to the surface using an aeroshell, parachute, and solid fuel rockets to slow the descent. An airbag system would soften the final landing shock. The landing site would be selected from available low-elevation areas large enough to accommodate anticipated targeting uncertainties.

Immediately after landing, the Lander would transmit engineering and science data collected during the entry and descent. The Lander camera would take a panoramic image of the surrounding martian terrain and transmit it directly to Earth during the first day of surface operations. A microrover would then be deployed from the Lander to the surface. Once deployed, the Rover would be independent of the Lander, except for command, telemetry, and data communications functions.

The landing would occur during summer in the northern hemisphere of Mars. A landing site near 15° North latitude would be preferred to maximize the solar incidence on the Lander solar arrays. The primary mission for the Rover would have a duration of about seven days, while the Lander surface mission would last 30 days.

2.1.1.2 Pathfinder Entry, Descent, and Landing Approach

The end-to-end entry, descent, and landing sequence (Figure 2-2), includes near-continuous, real-time, status data to characterize the performance of the flight system during the critical period prior to landing.

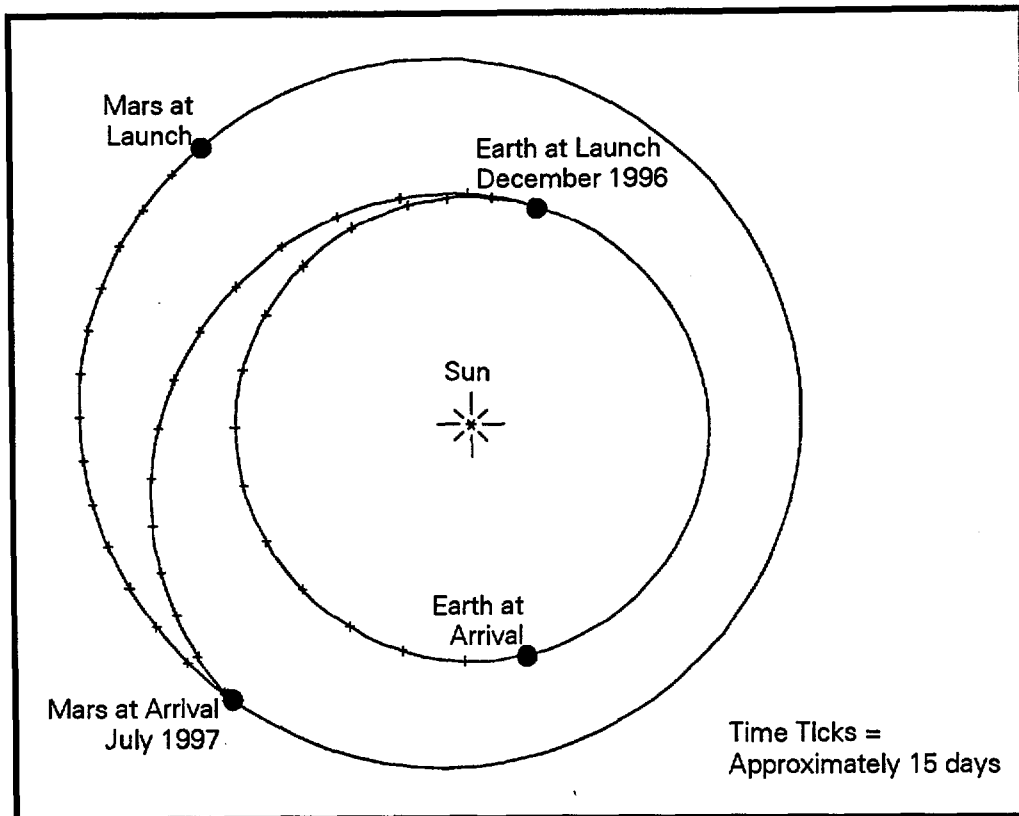

Figure 2-1. Mars Pathfinder Trajectory

A heat shield of ablative material would protect the Lander from the extreme heating experienced during the early atmospheric entry phase. During the entry and descent phases, accelerometers on the Lander would provide signals for parachute deployment and gather data to help characterize the structure of the atmosphere. Once the parachute is deployed, the heat shield would be jettisoned and the Lander's vertical velocity decreased to approximately 60 meters/second (about 197 feet/second) in the vicinity of the surface. During the parachute descent, the Lander would be lowered on a 20 to 40 meter (65 to 130 feet) tether below the backshell to provide separation from the retrorockets and improve stability during the rocket firing. A radar altimeter on the Lander would be used to determine when to ignite the three retrorockets mounted on the backshell above the Lander. The retrorockets would be similar to military ejection seat rockets, and sized to reduce the Lander velocity to less than 20 meters/second (about 66 feet/second) at surface impact.

Four airbags attached to the faces of the tetrahedral Lander would be inflated to absorb most of the landing shock, thereby limiting landing loads to less than 50 Earth g's. Just prior to contacting the surface, automatic cable cutters would release the

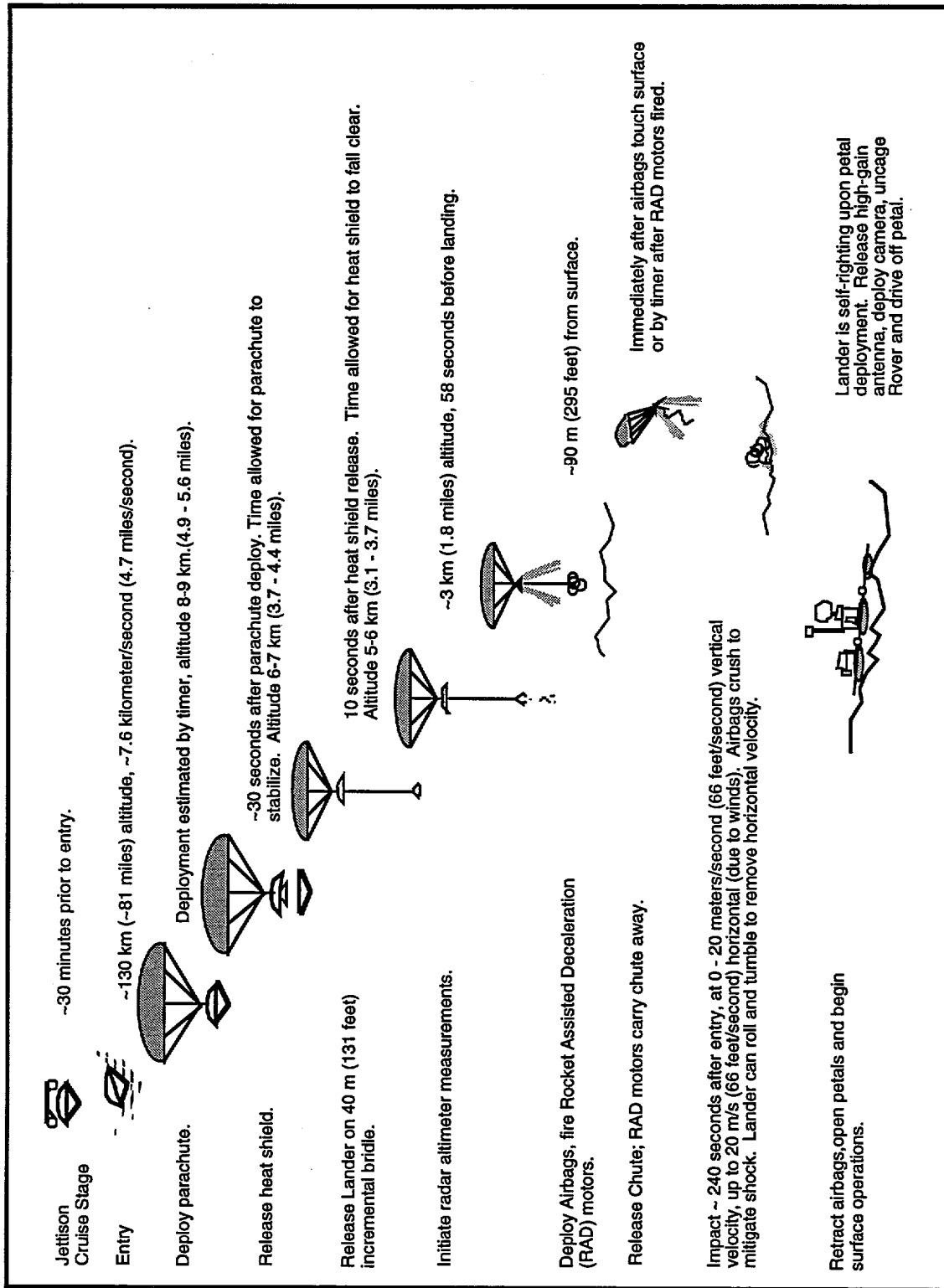

Figure 2-2. Mars Pathfinder Entry, Descent, and Landing (EDL) Sequence

Lander from the parachute, backshell, and retrorockets. After ground impact and tumbling, the airbags would deflate and be retracted. The three Lander petals would then open and ensure that the Lander establishes an upright configuration on the surface, with the solar arrays, science payload, and Rover exposed to the environment. Two-way communication with the Earth would be reestablished after the Lander executes a preprogrammed search to locate Earth. Programmed sequences would then command the acquisition and return of a panoramic image of the landing site and deployment of the Rover on the day of the landing.

2.1.2 Pathfinder Science Objectives [JPL 1993a]

Pathfinder is one of the first of NASA's Discovery Class missions: low-cost (\$150 M [FY '92 dollars] development cost cap), rapid-development programs with highly focused science objectives. The areas of scientific investigation for the Pathfinder mission are summarized in the following paragraphs.

2.1.2.1 Obtain Data on the Structure of the Martian Atmosphere Along the Entry and Descent Trajectory

During entry and descent through the martian atmosphere, instruments on the spacecraft would obtain data on the pressure, temperature, and density at different altitudes to help determine Mars' atmospheric structure.

2.1.2.2 Characterize the Landing Site Surface Morphology and Geology at Sub-Meter Scale

Current detailed knowledge of the martian surface is limited to the two Viking landing sites. Both indicated rocky, sandy, desert-like conditions, yet orbital images show the planet to have a wide variety of surfaces. Simple imaging of the area around the Lander would significantly increase the extent of our knowledge of surface morphology and geology (at sub-meter scale).

2.1.2.3 Monitor Meteorological and Atmospheric Conditions at the Landing Site

After landing, the spacecraft would also monitor meteorological conditions at the surface, such as atmospheric pressure, temperature, wind conditions and atmospheric dust, and water vapor content. These data would provide a valuable record of atmospheric conditions at the surface.

2.1.2.4 Investigate the Mineralogy and Elemental Composition of Rocks, Soil, and Surface Material

Current knowledge of the composition of Mars' surface materials is limited to orbital, remote-sensing measurements and a few life-detection tests performed by the Viking landers. Determination of the mineralogy and classification of these materials would provide ground-truth calibration for orbital, remotely sensed data and provide a broad interpretation base. Questions concerning the differentiation of the crust and the development of weathering products could also be addressed using this data base. Magnetic properties of airborne dust would be estimated by imaging adhesion to a set of magnets mounted on the Lander.

Data gathered on the surface could also help determine whether Mars is the origin of a class of meteorites, called the Shergotty, Nakhla, and Chassigny (SNC) meteorites, that impacted the Earth some 180 million years ago. Scientists believe the meteorites, discovered in Antarctica, are chemically similar to rocks found on the martian surface, and theorize that an object impacted Mars and threw material off its surface which subsequently impacted the Earth.

2.1.3 Pathfinder Engineering Objectives [JPL 1993a]

Pathfinder would also demonstrate critical engineering functions, systems, and technologies that are essential to the low-cost delivery of science payloads to Mars and the operation of these payloads as part of a long-term Mars exploration program. The following paragraphs describe the Pathfinder engineering objectives.

2.1.3.1 Interplanetary Cruise and Entry, Descent, and Landing System

The Pathfinder mission would demonstrate a simplified cruise approach to transfer the Lander from Earth to Mars, with a direct atmospheric entry from the Earth/Mars transfer orbit, rather than from an orbiting vehicle as was done for the Viking landers. Pathfinder would also demonstrate and characterize the performance of a low-cost, passive entry, descent, and landing system technical approach that could be applied to future Mars Lander missions.

2.1.3.2 Monitor and Evaluate Lander Performance in the Martian Environment

The Pathfinder Lander would demonstrate extended (minimum 30 days) surface operations using only solar and battery power to operate all Lander systems and maintain a thermal environment suitable for spacecraft systems operation. Direct-link radio communication between the Lander and Earth is also an objective.

2.1.3.3 Provide Systems Inheritance for Future Lander Missions

Pathfinder would also provide significant flight, mission, and operational systems inheritance for use in possible future Mars Lander missions, including design, technology, technical approaches, processes, procedures, and trained personnel.

2.1.3.4 Demonstrate the Use of a Rover Surface Vehicle for Instrument Deployment and Operation

The Pathfinder mission would enable demonstration of microrover operations in the martian environment to conduct technology investigations and serve as a science instrument deployment and operations platform.

2.1.4 Spacecraft Description

2.1.4.1 General

The Pathfinder spacecraft (Figure 2-3) consists of three major elements: the cruise stage, the deceleration subsystems, and the Lander (containing the Rover). The allocated launched spacecraft mass is 780 kg (1,716 pounds), including 100 kg (220 pounds) of hydrazine (N_2H_4) propellant, 9 kg (20 pounds) of science instruments, and an 11.5 kg (25 pounds), free-ranging Rover surface vehicle.

2.1.4.2 Cruise Stage

The cruise stage (Figure 2-4) would be the primary platform for implementing launch vehicle separation, attitude control, trajectory correction maneuvers, cruise telecommunications, and final Mars entry attitude placement. It contains equipment for solar power generation during cruise, the launch vehicle interface, a cruise antenna, propulsion tanks, valves, and thrusters, and attitude determination sensors.

A gallium arsenide (GaAs) solar array covers most of the top surface of the cruise stage. The propulsion subsystem consists of four titanium hydrazine propellant tanks connected with eight 4.54 Newton (1 pound force [lbf]) thrusters. Attitude determination during cruise would be based upon data provided by a star tracker and sun-sensor heads mounted to the cruise stage. Telecommunications and navigation tracking are provided through an antenna mounted on the upper surface of the cruise stage.

2.1.4.3 Deceleration Subsystems

Deceleration subsystems are required to reduce the Pathfinder direct atmospheric entry velocity of 7.65 km/second (about 4.75 miles/second), in order to accomplish a survivable landing on the martian surface. The deceleration subsystems

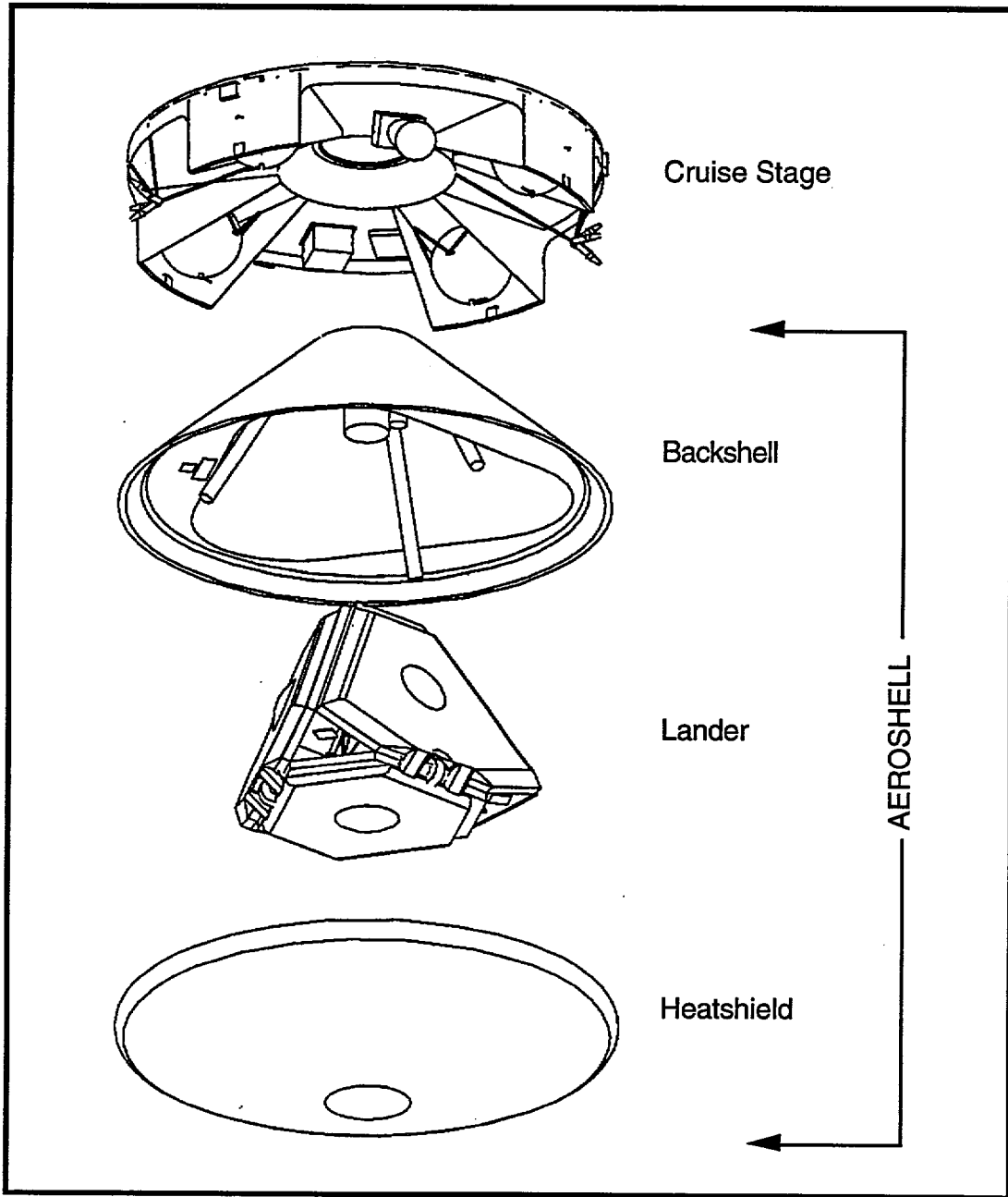

Figure 2-3. Pathfinder Flight System

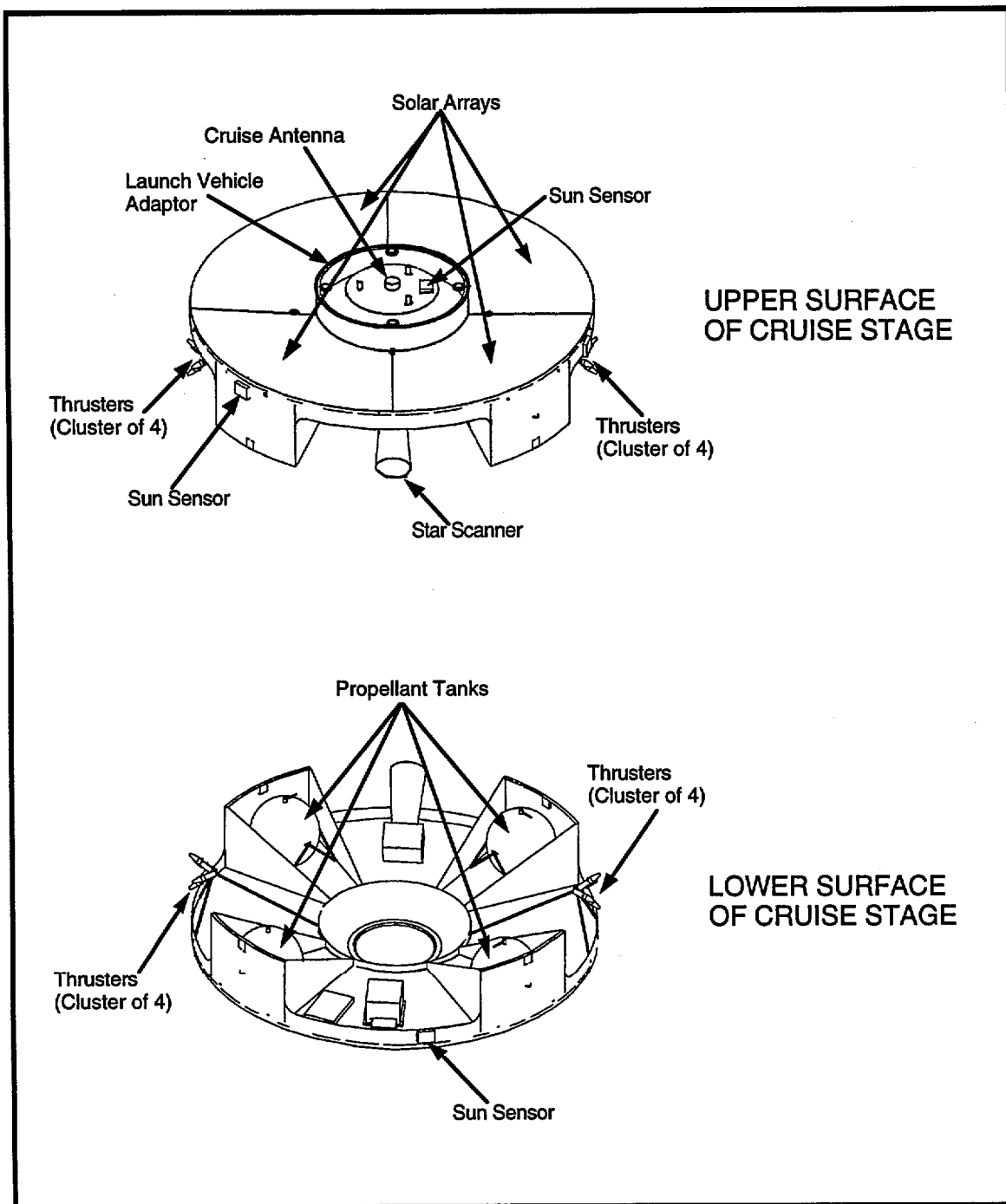

Figure 2-4. Mars Pathfinder Cruise Stage

would consist of an aeroshell (comprised of the heat shield and backshell, shown in Figure 2-3), engineering instrumentation, a parachute, an incremental tether, solid fuel retrorockets, and airbags.

2.1.4.4 Lander

The Lander (Figure 2-5) would provide access to the martian surface for the Rover, and would consist of the science and engineering instrument payload, the Lander deployment petals, airbag retraction mechanisms, a thermal enclosure, the Attitude and Information Management Subsystem (AIMS), and the Telecommunications Subsystem (TEL). Power to support all Lander functions would be derived from silicon solar arrays mounted on the exposed surfaces of the Lander deployment petals. The Lander thermal enclosure would provide a controlled temperature environment for thermally sensitive electronics, a power distribution network, and a silver-zinc battery to provide the energy storage capacity required to support periods of peak power usage and/or low solar insolation.

The AIMS would be a high-performance computer housed in the thermal enclosure. It would perform all Pathfinder computing functions, and would enable the interfaces with the Lander imager system, the accelerometers, and the RF modem to the Rover.

The TEL would provide direct two-way Earth communications capability, consisting of a transponder, a solid state power amplifier, a command detection unit (CDU); a telemetry modulation unit (TMU) would be housed in the thermal enclosure. Mounted above the enclosure would be an omnidirectional low-gain antenna (LGA) and a steerable high-gain antenna (HGA).

2.1.4.5 Spacecraft Pyrotechnic Devices

The Pathfinder spacecraft would use several types of pyrotechnic devices. There would be a total of 27 pyrotechnic events, most of which would be initiated by NASA Standard Initiators (NSIs). All pyrotechnics would be fired through redundant relays and initiators powered directly from the rechargeable battery, or from thermal batteries if the number of simultaneous firings exceeds six. The pyrotechnic switching assembly would have completed all of its functions before the Lander's first night on the martian surface.

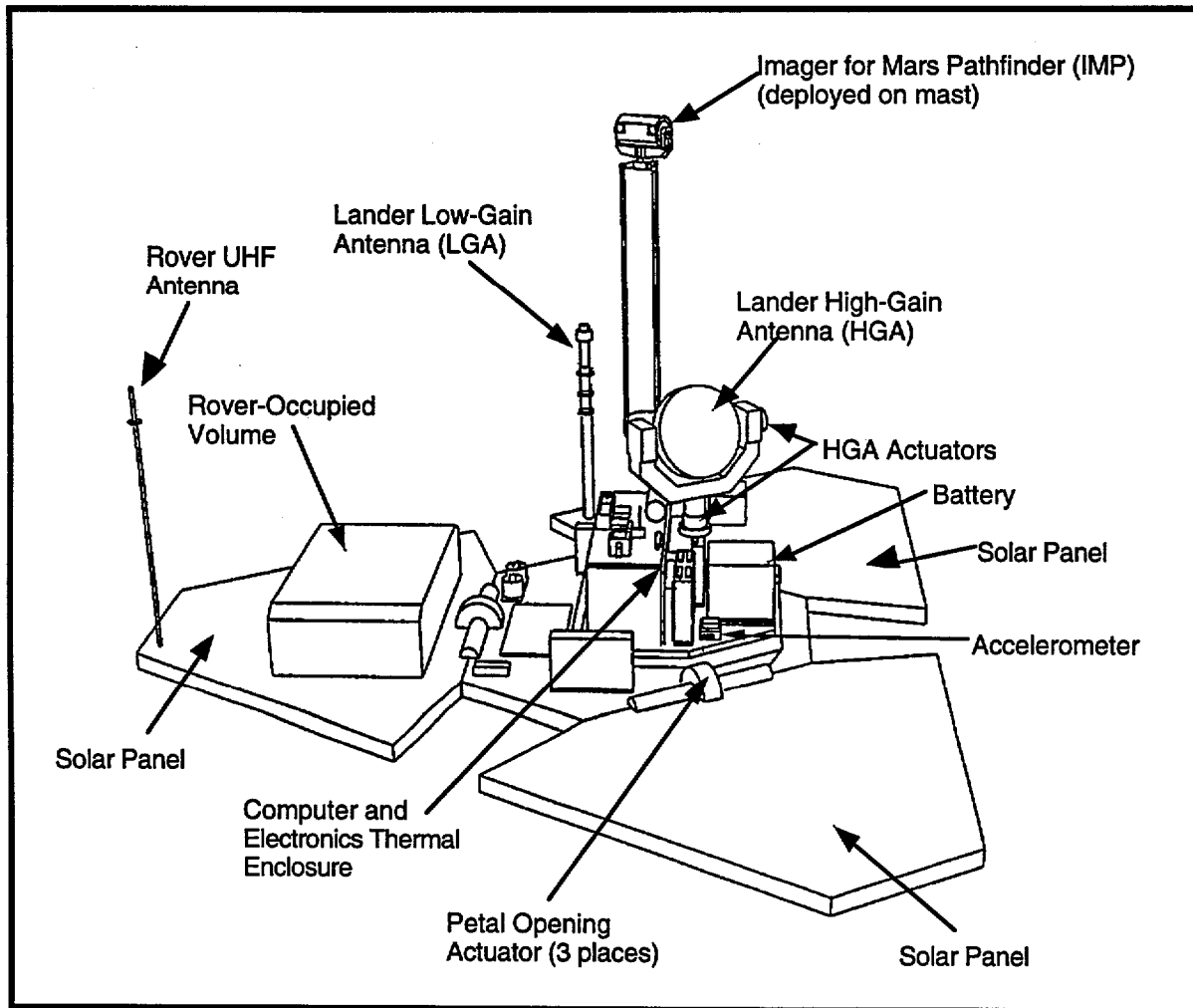

Figure 2-5. Pathfinder Lander Deployed Configuration

2.1.4.6 Science and Engineering Instrumentation

Scientific and engineering measurements would be collected during Mars entry, descent, landing, and surface operations. The Lander would carry three groups of instruments to accomplish these measurements. Two of the instrument groups would be contained within the Lander; the third would be mounted on the Rover.

2.1.4.6.1 Imager for Mars Pathfinder (IMP)

The Imager for Mars Pathfinder (IMP) would be a stereo imaging system with color capability. It consists of a camera head (with stereo optics, filter wheel, charge-coupled device [CCD] and pre-amp, and stepper motors) mounted at the top of a

deployable mast. When deployed, the mast provides an elevation of 0.8 meters (about 2.6 feet) above the Lander mounting surface.

The imaging investigation would include the observation of wind direction using a small wind sock mounted above a reference grid, and a calibration and reference target mounted on the Lander. The IMP would also support a magnetic properties investigation. A set of magnets of differing field strengths would be mounted to a plate and attached to the Lander. Images taken over the duration of the landed mission would be used to determine the accumulation of magnetic species of minerals in the wind-blown dust. Multispectral images of these accumulations could be used to differentiate among the several postulated mineral compositions.

2.1.4.6.2 Atmospheric Structure Instrument/Meteorology Package (ASI/MET)

The ASI/MET would be an engineering subsystem which provides data for scientific analysis. The ASI/MET consists of a three-axis accelerometer residing in the spacecraft Attitude and Information Management Subsystem (AIMS) and pressure and temperature sensors mounted on the Lander at locations suitable for measuring descent and post-landing conditions.

Pressure and temperature measurements acquired during the entry and descent of the Lander would aid in the reconstruction of profiles of atmospheric density, temperature, and pressure from higher than 100 kilometers altitude (about 61 miles) above the surface.

2.1.4.6.3 Alpha/Proton/X-Ray Spectrometer (APXS)

The Rover-deployed APXS would investigate the martian surface composition by stimulating soil and rock samples with alpha particles emitted from a radioactive source of curium-244 (Cm-244, approximately 2.78 gigabequerels [GBq], or 75 millicuries) and recording the alpha, proton, and X-ray spectra emitted from the sample. The Cm-244 required to operate this experiment would be located in the APXS instrument sensor head.

The APXS sensor head would be mounted external to the Rover chassis on a deployment mechanism. This mechanism, which places the APXS in contact with rock and soil surfaces, also interfaces the APXS with the microrover. The deployment mechanism would provide a means for positioning the APXS with a single degree of freedom mechanism. The linkage would be designed to allow the APXS to be placed at a variety of elevations above nominal ground level and at a variety of rotational orientations. The APXS electronics would be mounted within the Rover, inside a thermal enclosure. A set of contacts on the APXS front aperture ring would tell the Rover that positioning is complete, terminating the positioning motions.

2.1.5 Rover

2.1.5.1 General

The Rover (Figure 2-6) would have a mass of approximately 17 kg (about 37 pounds): the mobile mass of about 11.5 kg (about 25 pounds), including the APXS, and approximately 5 kg (about 11 pounds) for Lander-mounted Rover telecommunications equipment, structural support, and deployment mechanisms. The Rover would be 63 cm (25 inches) long, 48 cm (19 inches) wide, and have a deployed height of 28 cm (11 inches); the small dimensions would pose considerable challenges for mobility, thermal control, and power.

2.1.5.2 Rover Instrumentation

The Rover would conduct microrover technology experiments in the martian environment. This information would be collected by instrumenting the Rover mechanisms to determine wheel-soil interactions, detect hazards, determine navigational errors, and other performance data. Table 2-1 lists the experiments that would be performed by the Rover. The Rover would also gather science data by deploying the APXS against martian rock and/or soil, and engineering data by imaging the Lander to allow its condition to be assessed.

Table 2-1. Pathfinder Rover Experiments

TECHNOLOGY EXPERIMENTS Terrain Geometry Reconstruction/Characterization Basic Soil Mechanics Dead Reckoning Sensor Performance & Path Reconstruction/Recovery Sinkage In Each Soil Type Logging And Trending Of Vehicle Performance Data Rover Thermal Characterization Rover Vision Sensor Performance UHF Link Effectiveness Material Abrasion Material Adherence
SCIENCE EXPERIMENTS APX Spectrum Of At Least One Rock (10 Hours) At Least One APXS Measurement Of Soil Mono Image Of Rock Measured By APXS
MISSION EXPERIMENTS At Least One Mono Image Of Lander

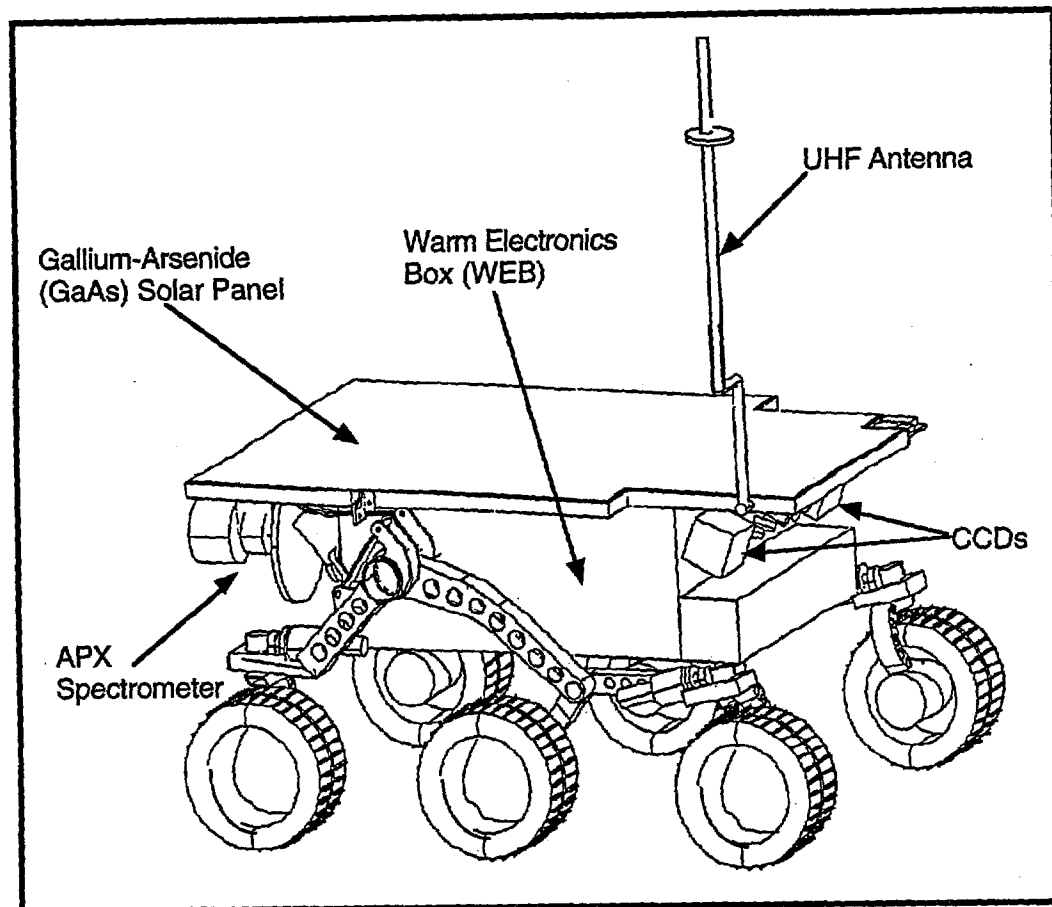

Figure 2-6. Pathfinder Rover

2.1.5.3 Rover Power Subsystem

The Rover would be powered by a GaAs solar panel, mounted on top of the Rover chassis. The power generated would be sufficient to power the Rover for several hours of operation per day, even in the worst dust storms. Primary, non-rechargeable, lithium thionyl chloride (LiSOCl_2) batteries providing 150 watt-hours of power would be used for power backup and augmentation. Non-rechargeable batteries would be used because they are much lighter than rechargeable batteries and the Rover mass would be severely limited. The batteries would be used to power Rover communications during cruise and night operations on the martian surface, and to provide additional power when navigating rough terrain.

2.1.5.4 Rover Thermal Control

Temperature-sensitive elements (electronics and batteries) of the Rover would be enclosed in a thermally insulated Warm Electronics Box (WEB). The WEB would be heated partially by the operation of the Rover electronics, which would be powered by the solar panel during daylight hours. Ideally, the Warm Electronics Box (WEB) would be insulated to prevent internal temperatures at night from dropping below -40°C (-40°F), the qualified operating temperature lower limit for the batteries and electronics. However, analysis indicates that the nighttime WEB temperature could drop below -60°C (-76°F). It is unlikely that the electronics and batteries would be able to operate at these temperatures and the Rover might be too cold to function after a single martian night. Based on this analysis of WEB temperatures, the baseline Rover design could include up to three Lightweight Radioisotope Heater Units (LWRHUs) as an additional heat source for the WEB.

Use of LWRHUs would ensure maintenance of the Rover WEB temperature range to between -30°C and $+30^{\circ}\text{C}$ (-22°F and $+86^{\circ}\text{F}$), well within the safety range for the Rover's sensitive electronic components. Additionally, with LWRHUs, a heater for the cruise portion of the Pathfinder mission would probably not be necessary, further simplifying the spacecraft and Rover implementation and operational risks.

2.1.5.4.1 Light Weight Radioisotope Heater Units

The LWRHU (Figure 2-7) is a small (26 mm diameter by 32 mm length, 40 g [about 1 inch by 1.25 inch, 1.4 ounce]), passive heat source that provides heat from the radioactive decay of plutonium-238 (Pu-238). LWRHUs are designed to provide heat safely and reliably to the Rover electronics. Each LWRHU contains about 2.7 g (about 0.1 ounce) of plutonium dioxide as a heat source in a single pellet, and produces approximately 1 thermal watt. About 80% of the plutonium is the isotope Pu-238. The pellet is surrounded by a platinum-rhodium alloy (Pt30Rh) clad which is fitted with a platinum frit vent to allow the escape of non-radioactive helium gas generated during the decay process, insulation systems of pyrolytic graphite, and a graphite aeroshell/impact body of fine-weave, pierced fabric [DOE 1988].

Radioisotope heaters of an earlier design were used successfully on the Pioneer and Voyager missions, and the current LWRHU design is in use on the Galileo spacecraft and probe. The LWRHUs are designed to contain the plutonium dioxide and have been demonstrated by testing to survive severe environments associated with launch accidents including reentry after earth orbital decay [DOE 1988]. In the launch configuration (Figure 2-8), the LWRHUs would be located on the Rover, inside an insulation package. The Rover would be attached to one of the Lander's petals. These petals are

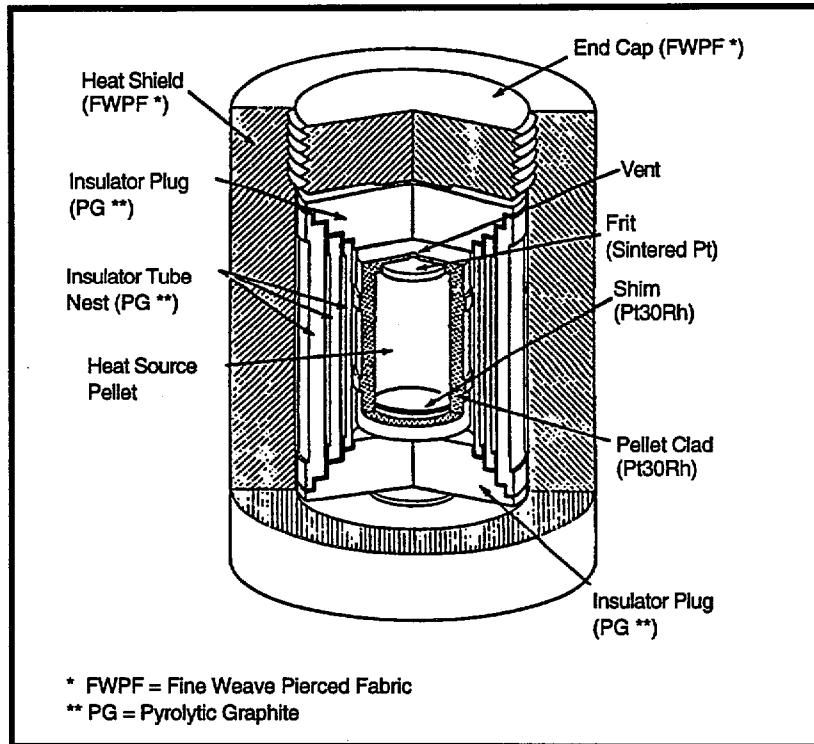

Figure 2-7. Light Weight Radioisotope Heater Unit (LWRHU)

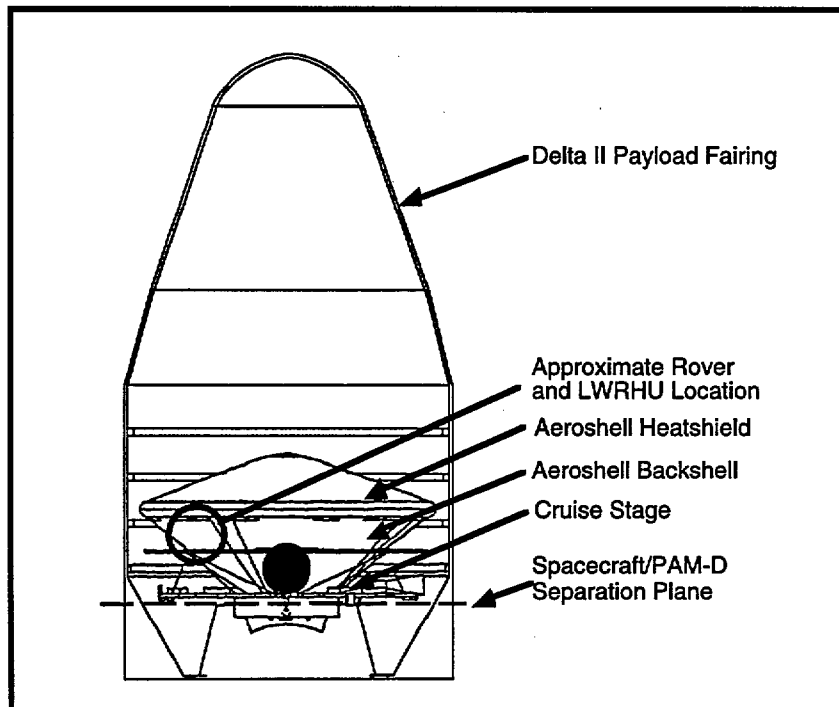

Figure 2-8. Pathfinder Orientation in the Delta II 7925 Payload Fairing

folded at launch, the Lander orientation being upside down inside the Mars Pathfinder aeroshell.

2.1.6 Launch Vehicle [MDSSC 1992]

The Delta II 7925 was selected as the baseline launch vehicle for the mission. The Delta II launch vehicle (Figure 2-9) consists of a payload fairing (PLF), the Delta II first and second stage propulsion systems with nine graphite epoxy motors (GEMs) used as strap-on boosters to the first stage, and a Payload Assist Module-Delta (PAM-D) upper stage.

2.1.6.1 Payload Fairing

During launch ascent, the Pathfinder spacecraft/PAM-D upper stage combination would be protected from aerodynamic forces by a 2.9 meter (9.5 feet) payload fairing. The PLF would be jettisoned from the launch vehicle during second stage powered flight at an altitude of at least 111 km (about 69 miles).

2.1.6.2 Delta II First and Second Stage

The first stage of the Delta II is powered by a liquid bipropellant main engine and two vernier engines. The first stage propellant load consists of 96,243 kg (211,735 pounds) of RP-1 fuel (thermally stable kerosene) and liquid oxygen as an oxidizer. First stage thrust is augmented by nine GEMs, each fueled with 11,870 kg (26,114 pounds) of Hydroxyl-Terminated PolyButadiene (HTPB) solid propellant. The main engine, vernier engines, and six of the GEMs are ignited at liftoff. The remaining three GEMs are ignited in flight. The GEMs are jettisoned after burnout of the solid propellant.

The Delta II second stage propulsion system has a bipropellant engine that uses Aerozine 50 (a 50/50 mix of hydrazine and unsymmetrical dimethyl hydrazine) as fuel and nitrogen tetroxide as oxidizer. The second stage has a total propellant load of 6,019 kg (13,242 pounds).

2.1.6.3 PAM-D Upper Stage

The PAM-D is the third stage of the launch vehicle and provides the final velocity required to insert the Pathfinder spacecraft into the trajectory to Mars. The PAM-D upper stage (Figure 2-10) consists of (1) a spin table to support, rotate, and stabilize the Pathfinder spacecraft/PAM-D combination before separating from the second stage, (2) a Star 48B solid rocket motor for propulsion, (3) an active Nutation Control System (NCS) to provide stability after spin-up of the spacecraft/ PAM-D stack, and (4) a payload attach fitting to mount the Star 48B motor to the spacecraft. The Star 48B is fueled with 2,010 kg (4,422 pounds) of solid propellant. The payload attach fitting, spacecraft

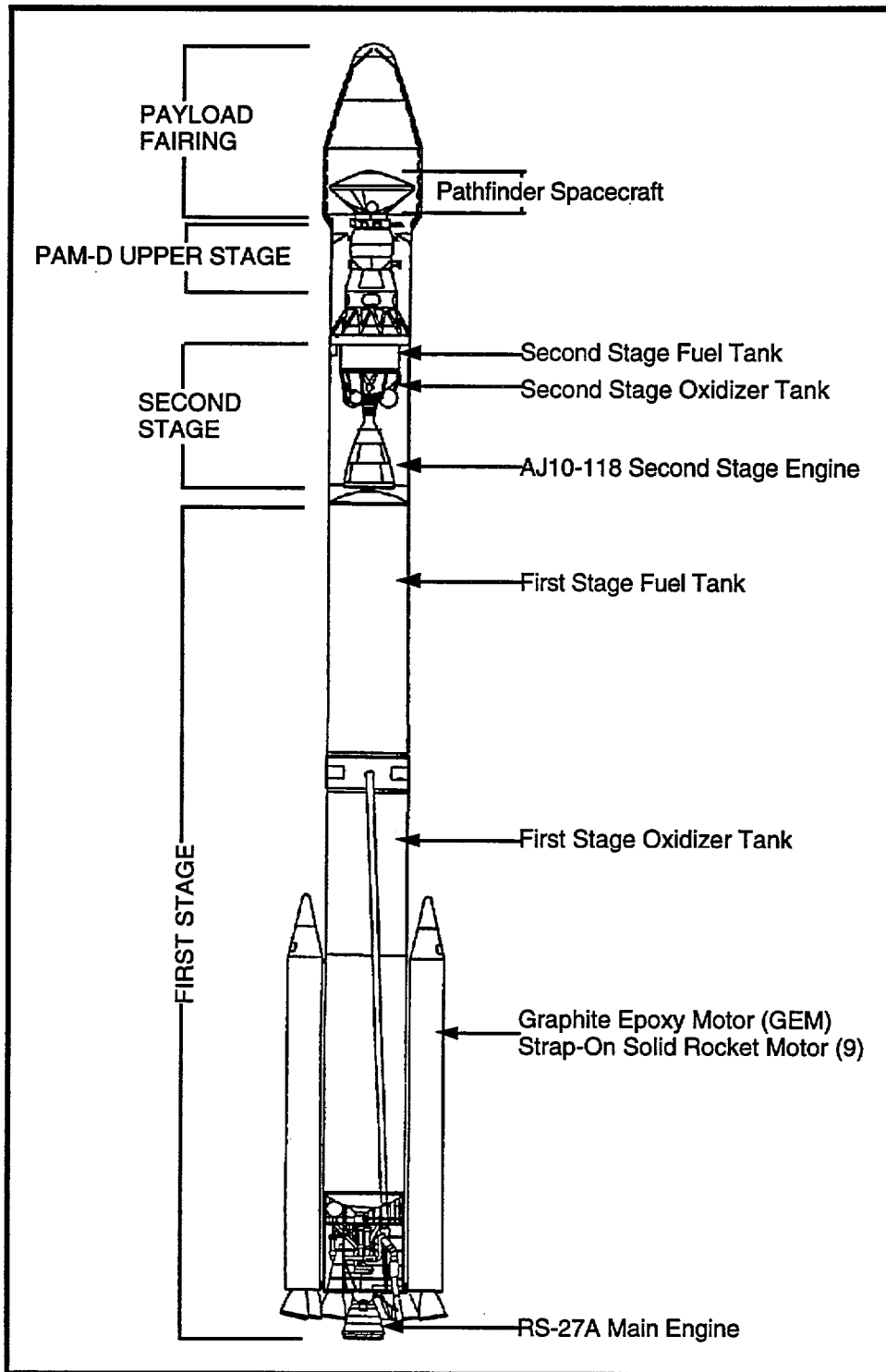

Figure 2-9. Delta II 7925 Launch Configuration

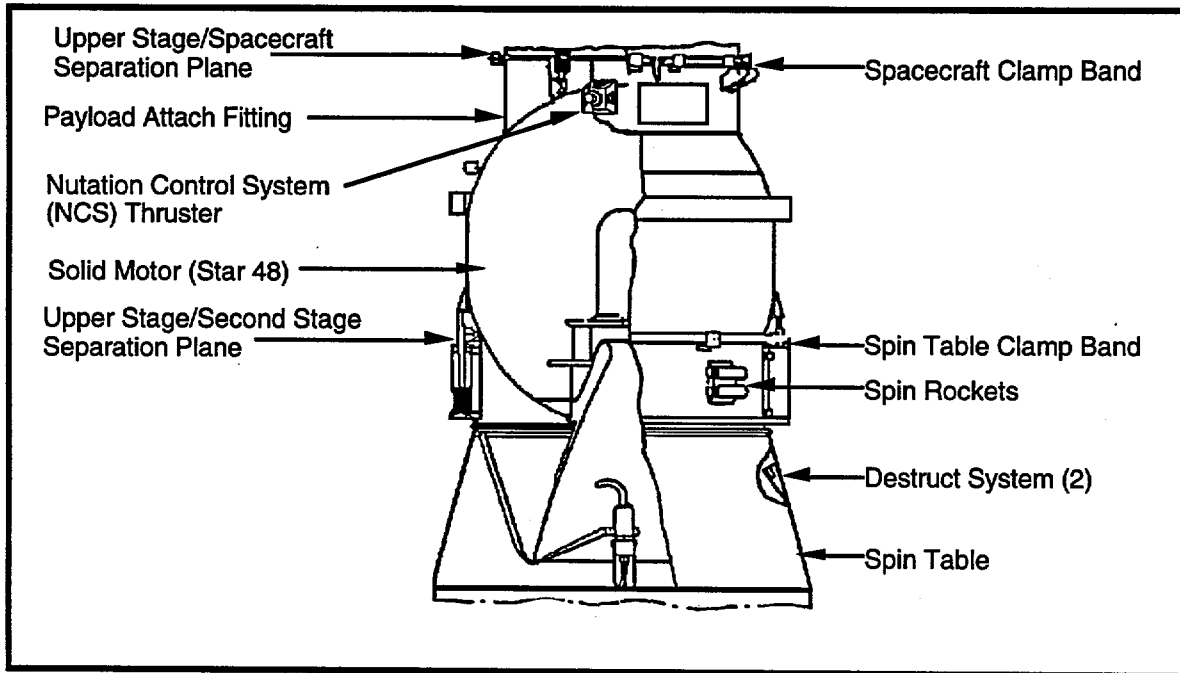

Figure 2-10. Payload Assist Module-Delta (PAM-D) Upper Stage

separation system, and cabling between the PAM-D and the spacecraft would not remain with the spacecraft after its separation from the upper stage.

2.1.6.4 Flight Termination System

The Eastern Range (ER) Range Safety Office would establish flight safety limits for the trajectory of the Pathfinder launch vehicle. These limits are established to ensure that errant launch vehicles (or debris resulting from a launch failure), do not pose a danger to human life or property. These flight safety limits are pre-determined before launch for the range of possible flight azimuths using predicted values for winds, explosively produced fragment velocities, human reaction time, data delay time, and other pertinent data. During a launch, if the vehicle trajectory indicates that these limits would be exceeded, the ER Range Safety Officer can take appropriate action, including destruction of the vehicle [MMSLS 1991].

As specified by Range Safety requirements, the Pathfinder launch vehicle would be equipped with a Flight Termination System (FTS). This system would be capable of destroying the vehicle based on commands sent from the Range Safety Officer. In the event of an unplanned separation of the first and second stages the FTS would automatically issue a destruct command. This function would be activated when electrical paths between stages are interrupted and stage separation commands have not been issued by the flight computer.

An electromechanical Safe and Arm (S&A) device would be located on each of the first and second stages. Once the FTS was activated, either by a Range Safety destruct command or by sensing vehicle breakup, the S&A device would permit the power and sequence box to trigger the destruction of the vehicle. The first stage S&A device would be connected to several strands of explosive detonating cord attached to the propellant tanks. When activated, these detonations would rupture the tanks, initiating the rapid burning and dispersion of propellants before the vehicle impacts the ground. The second stage S&A device would be connected to a linear shape charge designed to sever the second stage propellant tanks. This device would also be designed to activate the PAM-D FTS by detonating a set of conical shape charges to rupture the motor and render it non-propulsive [MDSSC 1991].

2.1.6.5 Launch Vehicle Debris

Delta launch vehicles use containment devices to mitigate the spread of debris generated during staging. Once separated, the Delta II payload fairing, first and second stage, and GEMs will not achieve Earth orbit. During their brief sub-orbital trajectories, any excess first and second stage propellants will be released to avoid potential tank rupture and breakup from over-pressurization caused by solar heating. The Pathfinder spacecraft/PAM-D upper stage will be "parked" in LEO for less than one hour before departing on a hyperbolic trajectory to Mars. [MDA 1993]

2.1.7 Cape Canaveral Air Station Operations

More than 200 Delta launches have occurred from CCAS Launch Complex 17 since May of 1960. During this long period of federally sponsored activities, launch preparation procedures have been well documented, standardized, and continuously reviewed. Pathfinder launch personnel would be trained in following established procedures.

Safe hardware and support equipment would be used to ensure safety for both personnel and equipment during all phases of fabrication, test, and operation. A Project Safety Plan (PSP) and a Missile System Pre-Launch Safety Package (MSPSP) would be prepared in accordance with JPL, Kennedy Space Center, and Air Force Eastern Range Safety Office requirements. A Safety Review Panel (SRP) High-Performance Work Team, as specified by Eastern Range Regulation (ERR) 127-1, would be convened and meet as required to review and guide the resolution of safety issues. The SRP would also provide recommended dispositions for the MSPSPs that would be submitted to the Air Force.

2.1.7.1 Launch Vehicle Processing

The Delta II first and second stages are initially received, inspected, and stored at Hangar M (Figure 2-11). They are moved to the Delta Mission Checkout (DMCO) Building for hardware integration and systems testing. The first stage would then be transferred to the Horizontal Processing Facility for installation of the destruct ordnance package, and prepared for erection at the launch site. The second stage would depart the DMCO Building for the Area 55 Second Stage Checkout Building for verification of hydraulic and propulsion systems and destruct ordnance package installation. Both the first and second stages would then be transported to the launch pad for integration and testing. The GEM solid rocket motors would receive all prelaunch processing in the Explosive Safe Area 60 (ESA 60) and Solid Motor Buildup Area 57 before being transported to the LC-17 launch pad and attached to the first stage [MDA 1993].

2.1.7.2 Spacecraft Processing

2.1.7.2.1 Planetary Protection Requirements

NASA has established policy for the protection of planetary environments from contamination by spacecraft, and has obtained international acceptance of this policy through the Committee on Space Research of the International Council of Scientific Unions. NASA implements this policy by establishing planetary protection requirements for each applicable mission. The Space Studies Board of the National Research Council has recommended to NASA that spacecraft targeted to Mars without life-detection instrumentation be subject to Class 100,000 clean room assembly and a precision cleaning of all components to reduce the potential bioload. The Mars Pathfinder Project will comply with all planetary protection policies and requirements specified by NASA and will document compliance in the Mars Pathfinder Planetary Protection Plan.

2.1.7.2.2 Spacecraft Component Assembly and Test Operations

The Pathfinder spacecraft would be transported to the Kennedy Space Center via surface carrier, arriving in late August 1996. At KSC, the component systems and subsystems would undergo parallel assembly and testing to verify proper operation of the subsystems prior to final assembly of the entire spacecraft [NASA 1994a].

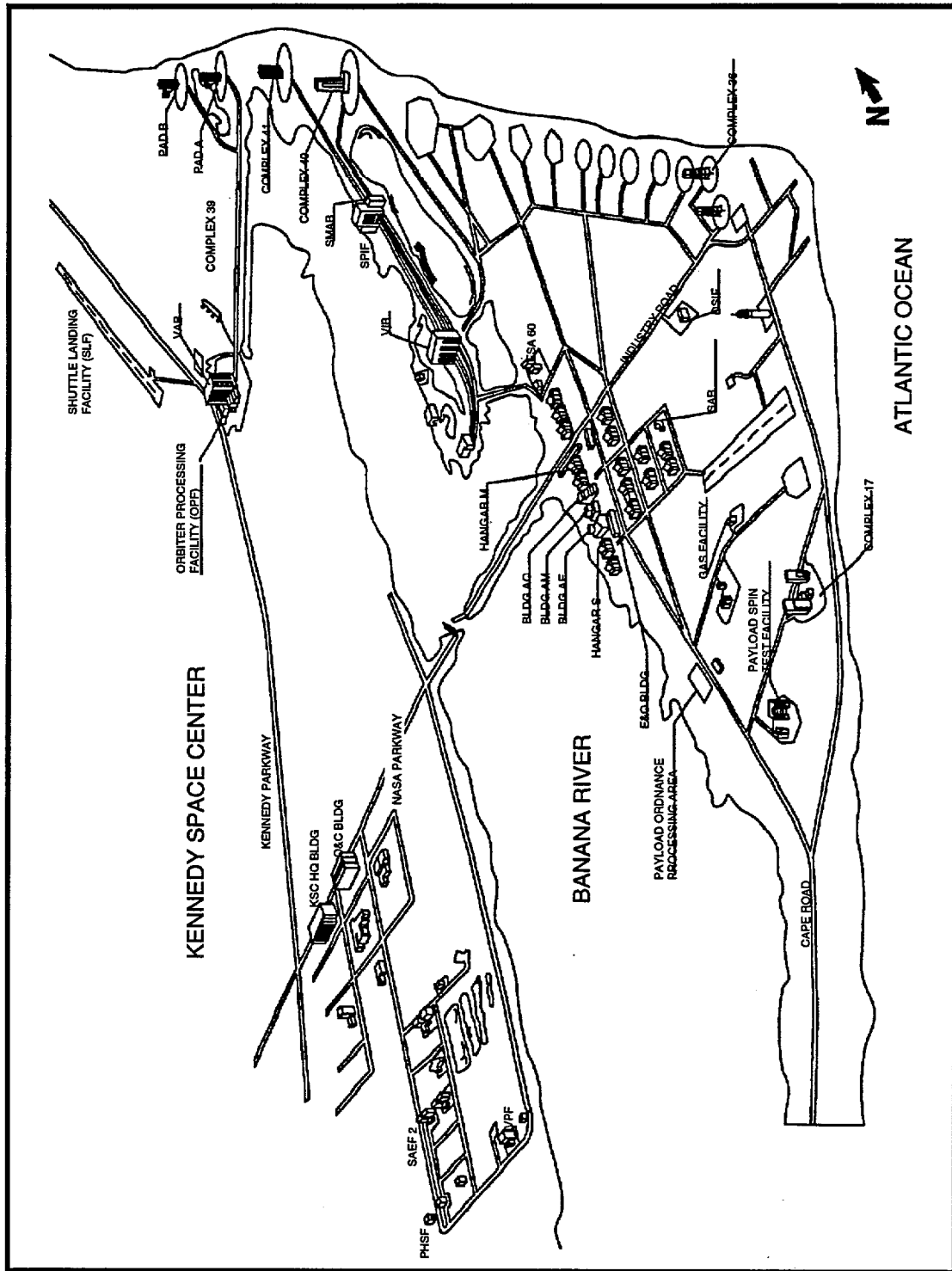

Figure 2-11. Launch Vehicle and Spacecraft Processing Areas, KSC/CCAS

Major component assembly activities would occur in a Hazardous Processing Facility (HPF), such as the Spacecraft Assembly and Encapsulation Facility #2 (SAEF-2) at KSC and would include:

- installation of the cruise stage flight battery
- installation of the RAD rockets into the backshell
- installation of the Lander flight battery
- installation of the LWRHUs into the Rover
- installation of the Cm-244 source into the APXS instrument

At each step in the assembly process, spacecraft components would be cleaned to comply with NASA's planetary protection requirements. After final assembly of the cruise stage and aeroshell, the spacecraft would be given a final cleaning and enclosed in a protective bag to prevent biological contamination. Assembly operations would be completed in early October 1996.

Following the final assembly and cleaning, propellants would then be loaded into the cruise stage tanks, and the spacecraft would be mated to the PAM-D upper stage. In mid-November 1996 the spacecraft and upper stage would be mated to the Delta launch vehicle, and final integrated tests with the launch vehicle would be conducted in preparation for the December 1996 launch.

2.1.7.2.3 Radioactive Materials Operations

The LWRHUs for the Rover would be delivered separately from the spacecraft by Department of Energy (DOE) transportation in accordance with existing DOE security and transportation requirements for radioactive materials. Storage and installation of the LWRHUs at KSC would probably occur in a HPF, and would be in accordance with DOE security and radiation safety requirements as well as the requirements of the KSC and CCAS Radiation Protection Programs [NASA 1993, USAF 1983].

The Curium-244 (Cm-244) source to be used in the APX Spectrometer instrument would also be delivered separately to KSC by the source provider, the University of Chicago [UOC 1994]. The storage and use of the Cm-244 source would be in accordance with the applicable federal and state regulations for possession and use of radioactive materials, and activities monitored by the local KSC/CCAS Radiation Protection Program personnel [NASA 1993, USAF 1983].

2.1.7.2.4 Pad Activities [NASA 1994a]

The spacecraft would arrive at the base of the pad and would be hoisted to the top of the launch tower payload level and mated to the launch vehicle. Once mated to the launch vehicle, interface verifications with the launch vehicle, launch

rehearsals, and power on/off stray voltage checks would be performed to verify spacecraft compatibility with the launch vehicle.

Integrated operations at the pad would also include:

- transporting the payload from the HPF to the pad
- erecting, uncanning, and mating payload
- cabling-up ground support equipment in the blockhouse to the payload
- conducting spacecraft functional tests
- installing the launch vehicle payload fairing

2.2 ALTERNATIVES TO THE PROPOSED ACTION

Alternatives to the proposed action that were considered included those that: (1) reduce or eliminate the plutonium heat sources needed for Rover thermal control, (2) utilize an alternate launch vehicle/upper stage combination, and (3) cancel the Pathfinder mission (the No-Action alternative).

2.2.1 Reduce or Eliminate the Plutonium Heat Sources

The Rover has little heat retention capability due to its exceptionally small size and mass. The martian night would expose the Rover to temperatures as low as -100°C (-148°F); a thermal environment the Rover electronics and batteries would not tolerate. Many of the Rover's electronic components are commercial parts, selected to conform to the cost, mass, volume, and power limitations imposed on the Rover design. These parts have been qualified for operation at greater than -40°C (-40°F). The Rover electronics and batteries are qualified for survival (non-operating) only to -55°C (-67°F).

Without an additional source of heat, analysis indicates that equipment temperatures inside the WEB thermal enclosure could drop to approximately -60°C (-76°F). To maintain a favorable thermal environment for the electronics and batteries without the use of the plutonium heat sources (LWRHUs), either additional insulation must be added to the thermal enclosure, or additional heat must be provided from an electrical power source.

2.2.1.1 Insulating the Warm Electronics Box Thermal Enclosure

To accomplish the objectives of the Pathfinder mission within the cost constraints levied on the mission, both the Lander and the Rover are subject to stringent mass and volume limitations.

The current WEB design includes a double-walled fiberglass box, with honeycomb insulating material between the two walls. The interstices of the

rehearsals, and power on/off stray voltage checks would be performed to verify spacecraft compatibility with the launch vehicle.

Integrated operations at the pad would also include:

- transporting the payload from the HPF to the pad
- erecting, uncanning, and mating payload
- cabling-up ground support equipment in the blockhouse to the payload
- conducting spacecraft functional tests
- installing the launch vehicle payload fairing

2.2 ALTERNATIVES TO THE PROPOSED ACTION

Alternatives to the proposed action that were considered included those that: (1) reduce or eliminate the plutonium heat sources needed for Rover thermal control, (2) utilize an alternate launch vehicle/upper stage combination, and (3) cancel the Pathfinder mission (the No-Action alternative).

2.2.1 Reduce or Eliminate the Plutonium Heat Sources

The Rover has little heat retention capability due to its exceptionally small size and mass. The martian night would expose the Rover to temperatures as low as -100°C (-148°F); a thermal environment the Rover electronics and batteries would not tolerate. Many of the Rover's electronic components are commercial parts, selected to conform to the cost, mass, volume, and power limitations imposed on the Rover design. These parts have been qualified for operation at greater than -40°C (-40°F). The Rover electronics and batteries are qualified for survival (non-operating) only to -55°C (-67°F).

Without an additional source of heat, analysis indicates that equipment temperatures inside the WEB thermal enclosure could drop to approximately -60°C (-76°F). To maintain a favorable thermal environment for the electronics and batteries without the use of the plutonium heat sources (LWRHUs), either additional insulation must be added to the thermal enclosure, or additional heat must be provided from an electrical power source.

2.2.1.1 Insulating the Warm Electronics Box Thermal Enclosure

To accomplish the objectives of the Pathfinder mission within the cost constraints levied on the mission, both the Lander and the Rover are subject to stringent mass and volume limitations.

The current WEB design includes a double-walled fiberglass box, with honeycomb insulating material between the two walls. The interstices of the

honeycomb material are filled with an insulating material to further reduce the heat loss. Heat loss from wiring between external Rover elements and the WEB electronics is minimized by selection of small-diameter wire and by careful design of cable runs. The WEB is heated by waste heat from operation of the electronics, and by heaters operated from the solar panels.

Analysis of WEB efficiency indicates that the design would maintain an interior WEB temperature above -60°C (-76°F) if the highest possible amount of heating were captured (i.e., if the solar insolation were normal), if no LWRHUs are used. Figure 2-12 shows the effect of adding LWRHU heat sources. Rover electronics and batteries are qualified (non-operating) only to -55°C (-67°F). At least one LWRHU would be required to maintain the WEB above the -55°C (-67°F) temperature limit.

The Rover electronics and batteries are qualified to operate only above -40°C (-40°F). Without the use of LWRHUs, figure 2-12 indicates that the WEB equipment would be above this temperature only for about 62 percent of the martian sol (approximately 26 Earth-hours), and would be below -40°C (-40°F) for almost the entire martian night. The baseline mission plan requires the Rover to power the APXS instrument at night using the Rover batteries, to avoid wasting a day (i.e., with the Rover stationary) while the 10-hour APXS spectrum collection was being performed. For the batteries to operate requires that the WEB interior temperature remain above -40°C (-40°F), which would not be feasible without the use of the LWRHUs; even if one LWRHU were used, the batteries would not operate for five hours at night. This would drive the minimum mission duration for the Rover to be at least one, and possibly two, days longer per APXS sample taken.

Because of cost, mass, volume, and power constraints the Rover must utilize many commercial parts (UHF modems, power converters, etc.). Failure of these components would be highly likely, if cycled several times below their qualified minimum temperatures. This cycling would be unavoidable if LWRHUs are not used to augment WEB heating. This combination of potentially shorter component lifetimes and the extended mission life requirements discussed above increases the risk of not accomplishing the minimum Rover mission objectives.

2.2.1.2 Operating Electric Heaters With the Rover Batteries

Powering electric heaters at night with the Rover batteries would not be feasible, since the batteries are not rechargeable and their energy likely would be consumed after the first martian night, ending Rover operations prior to the completion of its primary mission and precluding use of the APXS instrument.

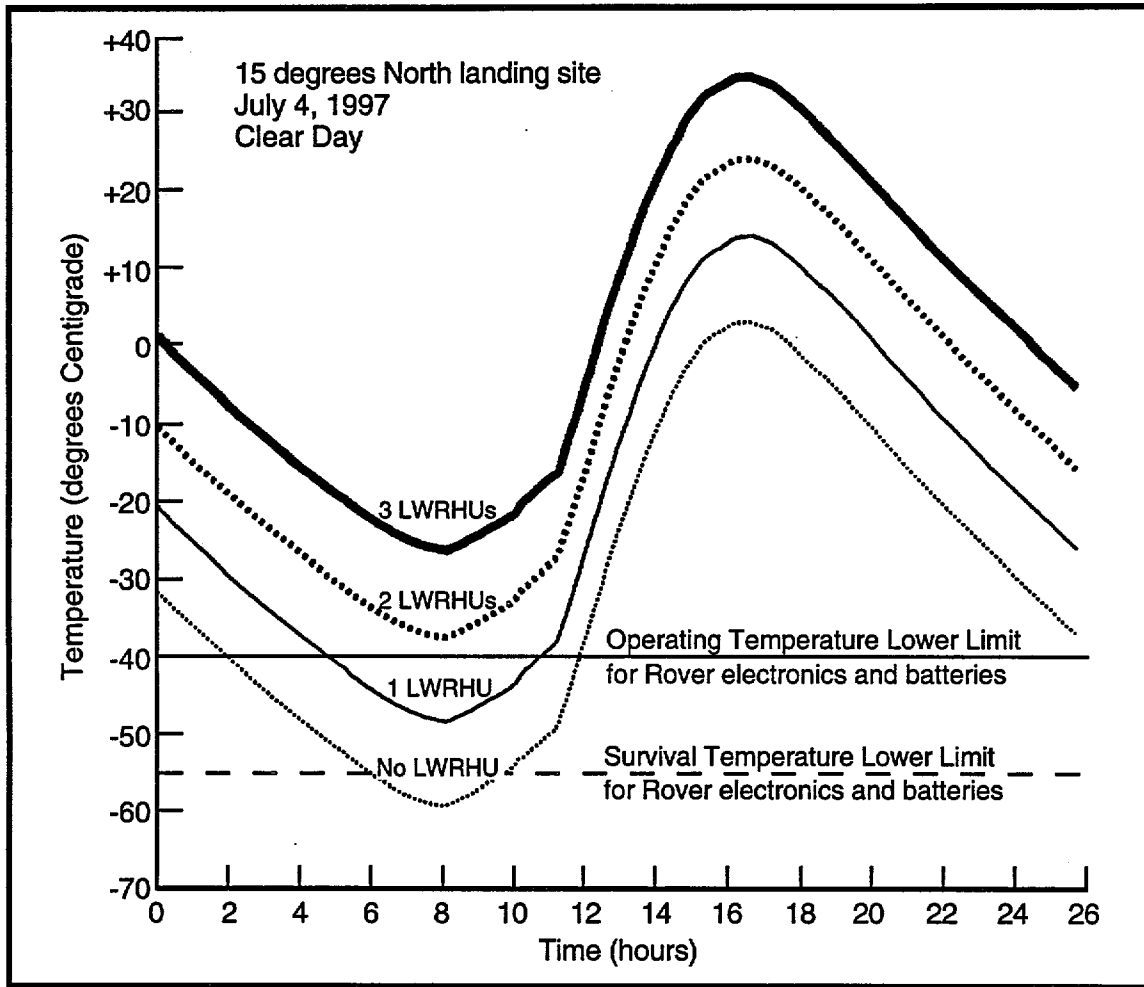

Figure 2-12. Mean WEB Equipment Temperature Profile with Differing Numbers of LWRHUs

2.2.1.3 Operating Electric Heaters Via a Lander Power Umbilical

Electric heaters could be operated via a power umbilical from the Lander to the Rover. However, interfaces between the Rover and the spacecraft must be kept as simple as possible to enhance system reliability. Hence, there would be no power or data connections between the Rover and the spacecraft. Rover system status during the cruise to Mars and data collected during surface operations would be transmitted from the Rover to the Lander via a UHF radio link, and then from the Lander to Earth. WEB thermal control during the cruise to Mars would be maintained by the Pathfinder spacecraft as part of its normal thermal control design.

Additionally, installing a power umbilical would, in effect, tether the Rover and restrict its surface exploration to only a short distance from the Lander. As well as

significantly limiting the Rover's mobility, an umbilical would vastly complicate surface operations by introducing the threat of entanglement. The complexities of this approach would also seriously jeopardize Rover science collection (APXS analyses of martian surface composition) and would negate technology demonstrations of autonomous surface navigation, one of the primary objectives of the Rover mission.

2.2.1.4 Summary

There is a high probability that the Rover thermal design would be unable to protect the electronics and batteries if LWRHUs are not used. Three LWRHUs would maintain the WEB equipment temperatures within the required temperature qualification limits over the range of possible WEB insulation efficiencies.

2.2.2 Alternate Launch Systems

2.2.2.1 Selection Criteria

Selecting a launch vehicle/upper stage combination (launch system) for a planetary mission largely depends on matching the payload mass and the energy required to achieve the desired trajectory to the capabilities of the prospective launch system. The more massive the payload and the more energy required to achieve the trajectory, the more powerful the launch system required. The most desirable launch system would meet, but would not greatly exceed, the mission's minimum launch performance requirements.

For the Mars Pathfinder mission, constraints on launch system performance are the Pathfinder launch mass of approximately 780 kg (1,716 pounds) and an injection energy (C_3) of $22 \text{ km}^2/\text{s}^2$.

Other considerations which must be addressed in selection of the launch system include reliability, cost, and potential environmental impacts associated with use of the launch system.

Feasible alternative Pathfinder launch systems are potentially available from both foreign and domestic manufacturers. Potential alternative launch systems from foreign manufacturers include the European Space Agency (ESA) Ariane and the Russian Proton. Potential alternative U.S. launch systems include the Space Transportation System (STS) and various Atlas, Delta, and Titan configurations [JPL 1993].

2.2.2.2 Foreign Launch Systems

Of the foreign launch systems that are potentially available for the Pathfinder mission, the ESA Ariane 44L and the Russian Proton most closely match the Pathfinder

requirements for performance and injection energy. However, both of these vehicles exceed by a wide margin the Pathfinder mission requirements, and there is not a clear environmental advantage in their use. Additionally, current U.S. government policy prohibits the launch of U.S. government-sponsored spacecraft on foreign launch systems. Therefore, these foreign launch systems are not considered to be reasonable alternatives.

2.2.2.3 U.S. Launch Systems

2.2.2.3.1 Space Transportation System

The STS greatly exceeds the Pathfinder mission requirements and would not be considered a reasonable alternative launch system.

2.2.2.3.2 U.S. Expendable Launch Systems

Potential alternative U.S. expendable launch systems include the Titan IIG/Star 48, the Delta II 7325/Star 48, the Titan IIS/Star 48, the Delta II 7925/PAM-D, and the Atlas I/Centaur.

- Neither the Titan IIG/Star 48 nor the Delta II 7325/Star 48 meet the minimum mass performance criteria, and are not considered as reasonable alternatives.
- The Titan IIS/Star 48 would potentially meet the mass and C₃ performance criteria, but the Titan IIS is only in the conceptual stage, and further development would be contingent upon Martin Marietta proposal and selection for NASA's Intermediate Expendable Launch Vehicle (IELV) contract. The level of schedule and performance risk associated with this launch system at this time make it an undesirable alternative.
- Both the Delta II 7925/PAM-D and the Atlas I/Centaur launch systems meet the minimum Pathfinder mission requirements. However, the Delta II 7925/PAM-D system costs approximately 25 million (FY '92) dollars less than the Atlas I/Centaur and has a higher reliability than the Atlas I launch system.

2.2.2.4 Summary

Of the launch systems examined, the Delta II 7925/PAM-D combination is the best-suited for the Pathfinder mission, for the reasons listed below:

- The mass performance of the Delta II 7925/PAM-D most closely matches the Pathfinder performance requirement [JPL 1993].

- The Delta II 7925/PAM-D is the more reliable alternative launch system of those systems meeting the Pathfinder performance criteria.
- The Delta II 7925/PAM-D is the lower cost alternative launch system of those systems meeting the performance criteria [JPL 1993].
- Of the reasonable alternative launch systems examined, all were approximately equal in their potential environmental impacts [DOT 1986].

2.2.3 No-Action Alternative

The No-Action alternative would result in not undertaking the mission.

SECTION 3
GENERAL ENVIRONMENTAL CHARACTERISTICS OF CAPE CANAVERAL
AIR FORCE STATION AND SURROUNDING AREA

The information provided in this section is summarized from the reference documents cited in the text. Refer to those references for more complete information and maps of environmental resources.

3.1 REGIONAL AND LOCAL ENVIRONMENT

For the purposes of this document, the region of interest (Figure 3-1) consists of the six county area of Volusia, Seminole, Lake, Orange, Osceola, and Brevard counties.

The Cape Canaveral Air Station is located in Brevard County on the eastern coast of Florida, near the city of Cocoa Beach and 75 km (45 miles) east of Orlando. The station occupies nearly 65 square km (25 square miles) of the barrier island that contains Cape Canaveral, and is adjacent to the National Aeronautics and Space Administration Kennedy Space Center, Merritt Island, Florida. CCAS is bounded by KSC on the north, the Atlantic Ocean on the east, the city of Cape Canaveral on the south, and the Banana River and KSC/Merritt Island National Wildlife refuge on the west (Figure 3-2).

3.1.1 Population Distribution

For the last forty years, the population and economy of Brevard County has been closely linked to the growth of the space program. There was a constant influx of aerospace contractors and military personnel from the early 1950s through the mid-1960s. Employment levels dropped in the late-1960s, however, reflecting major cutbacks in NASA operations. The local aerospace economy recovered after 1979 due to a renewed national emphasis on launch activities.

The CCAS employs approximately 11,700 people, but has no permanent residents. About 95 percent of the installation's military and civilian contractor personnel live in Brevard County, with the remainder residing in the surrounding counties. Major population centers include Titusville (20 km [12 miles] northwest), Cocoa Beach (13 km [8 miles] south), Cocoa (12 km [7 miles] southwest), and Cape Canaveral (0.8 km [0.5 miles] south). All military personnel serving at the station are assigned to Patrick Air Force Base, about 25 km (15 miles) to the south of CCAS. [USAF 1990]

The population growth rate for Brevard County has been projected at 3.2 percent through 1995; this would imply a population of about 473,000 by that year. The

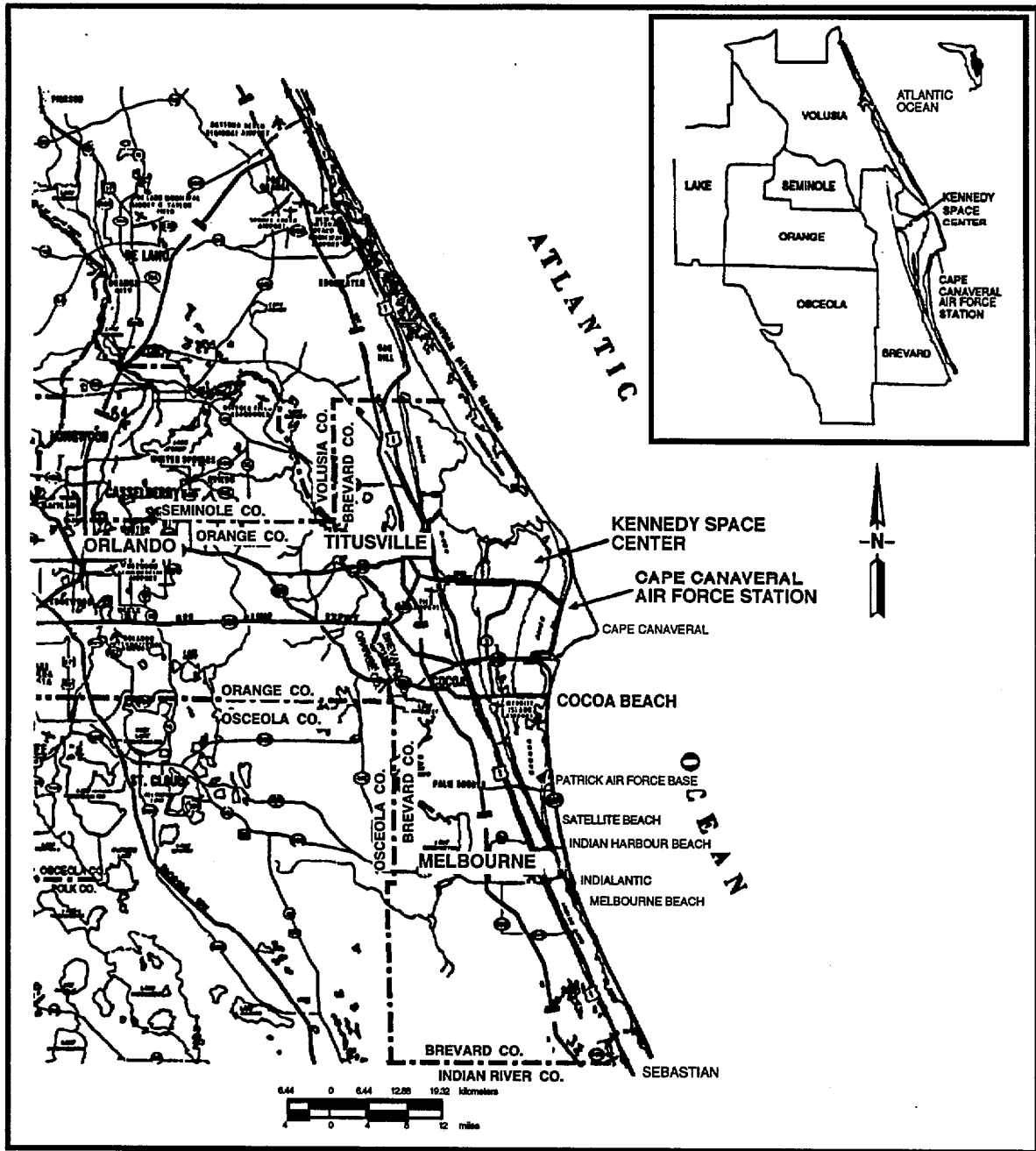

Source: [NASA 1986]

Figure 3-1. Regional Area of Interest

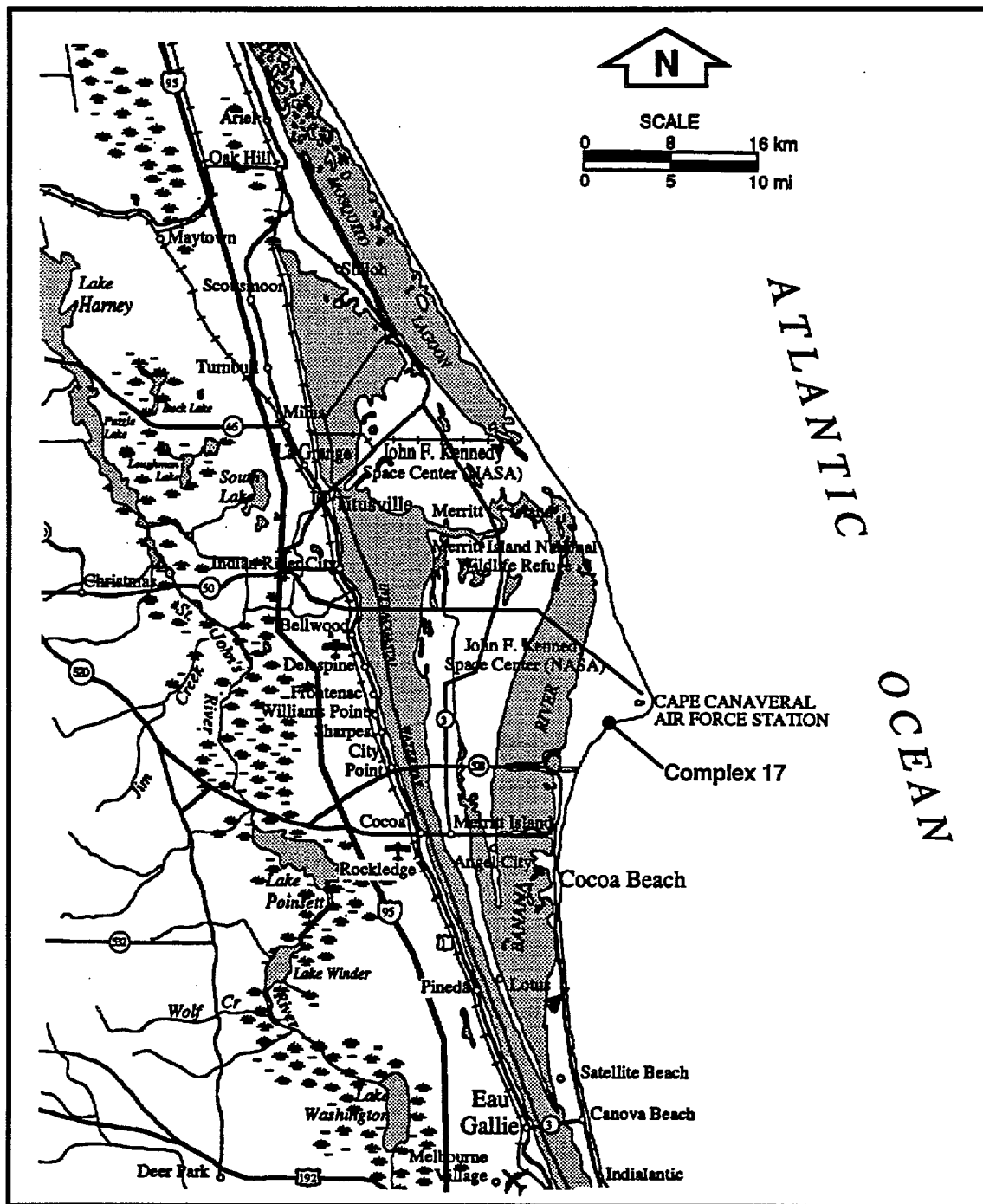

Source: [NASA 1986]

Figure 3-2. Location of CCAS Relative to the Region of Interest

greatest increase is expected to occur in southern Brevard County and the lowest in the central portion of the county [USAF 1990]. In February 1990, Brevard County's civilian labor force was 178,359 and the unemployment rate was 5.4 percent. The employment base for the region consists primarily of manufacturing, retail trade, services (with an emphasis on tourism), and government-related enterprises. Brevard County workers received a total personal income of nearly \$5.5 billion in 1987, which translates to a per capita income of \$14,650 [USAF 1991].

3.1.2 Land Use

Only about 8 percent, or 132,742 hectares (ha) (328,000 acres), of the total region (1.7 million ha; 4.1 million acres) is urbanized [ECFRPC 1992], with the largest concentrations of people occurring in three metropolitan areas:

- Orlando, in Orange County, expanding into the Lake Mary and Sanford areas of Seminole County to the north, and into the Kissimmee and St. Cloud areas of Osceola County to the south,
- the coastal area of Volusia County, including Daytona Beach, Port Orange, Ormond Beach, and New Smyrna Beach, and
- along the Indian River Lagoon and coastal areas of Brevard County, specifically the cities of Titusville, Melbourne, and Palm Bay.

Approximately 85 percent of the region's population lives in urban areas.

The majority of the region is considered rural, which includes agricultural lands and their associated trade and service areas, conservation and recreation lands, and undeveloped areas. About 35 percent of the regional area is devoted to agriculture, including more than 5,000 farms, nurseries, and ranches. Agricultural areas include citrus groves, winter vegetable farms, pasture land and livestock, foliage nurseries, sod farms, and dairy land.

In Brevard County, approximately 68 percent of the developed land use is agricultural, 12 percent is residential, 2 percent is commercial, 1 percent industrial, and 1 percent institutional. The remaining 16 percent is comprised of various other uses. The developed land areas are clustered in three areas in a north-south pattern along the coast and the banks of the Indian and Banana Rivers [USAF 1990].

Approximately 30 percent of the CCAS (about 1,880 ha; 4,700 acres) is developed, and consists of launch complexes and support facilities (Figure 3-3). The remaining 70 percent is comprised of unimproved land. The CCAS also contains a small industrial area, the Air Force Space Museum, Canaveral Harbor for the docking of submarines, and an airstrip that was initially constructed for research and development in recovery operations for missile launches. Many of the hangars located on the station are

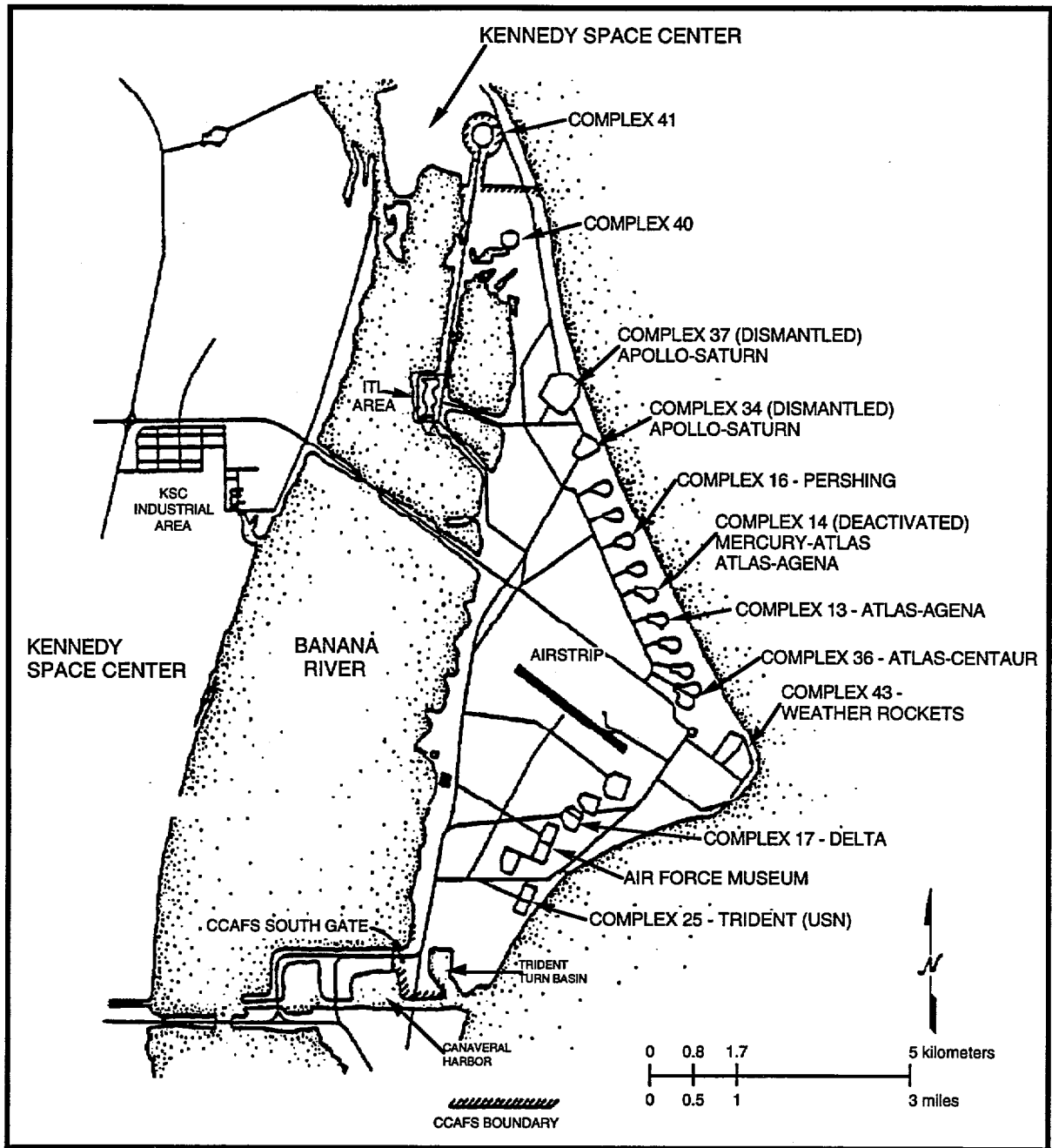

Source: [USAF 1986]

Figure 3-3. Land Use at CCAS

used for missile assembly and testing. Future land use patterns are expected to remain similar to current conditions. The Kennedy Space Center (KSC) occupies almost 56,000 ha (about 140,000 acres), about 5 percent of which is developed land. Nearly 40 percent of the KSC consists of open water areas, such as portions of the Indian and Banana Rivers, Mosquito Lagoon, and all of Banana Creek [USAF 1990].

Launch Complex 17 (Figure 3-4) is located in the southern portion of the CCAS, approximately 0.8 km (0.5 miles) west of the Atlantic Ocean, 2.5 km (1.5 miles) east of the Banana River, and roughly 5.7 km (3.4 miles) from the station's South Gate. The complex consists of two launch pads, 17A and 17B, each with its own mobile Missile Service Tower, Fixed Umbilical Tower, cable runs, and Fuel Storage Area.

A concrete exhaust flume on each pad deflects exhaust gases away from the pad to reduce the noise and shock wave that result from ignition of solid rockets and the first stage of the launch vehicle. The launch complex includes a water deluge system that sprays water directly into the solid rocket exhaust plume to reduce acoustic loads on the vehicle.

The two launch pads share common gas storage facilities, located in bunkers between the pads, and are monitored from a common blockhouse, located at a distance from the launch pads. Other miscellaneous support and service facilities are shared between them, as well. LC-17 was renovated in the late 1980s to support an upgraded version of the Delta launch vehicle.

3.1.3 Economic Base [NASA 1990]

The region's economic base is tourism and manufacturing. Tourism-related employment includes most jobs in amusement parks, hotels, motels, and campgrounds, as well as many occupations in the retail trade and various types of services. Manufacturing jobs, while probably outnumbered by tourism jobs, may provide more monetary benefits to the region because of higher average wages and a larger multiplier effect.

The region's agricultural activities include citrus groves, winter vegetable farms, pastures, foliage nurseries, sod, livestock, and dairy production. In the central region, 30 percent of the land is forested and supports silviculture, including harvesting of yellow pine, cypress, sweetgum, maple, and bay trees. In Osceola County, large cattle ranches occupy almost all of the rural land. Agricultural employment declined in 1986 to just 2.2 percent of the region's employment base.

Commercial fisheries in the two counties bordering the ocean (Brevard and Volusia) landed a total of approximately 9,727 metric tons (about 21.4 million pounds) of finfish, invertebrates, and shrimp in 1988. Brevard and Volusia Counties ranked third and fourth, respectively, among the east coast counties of Florida in total 1988 finfish landings.

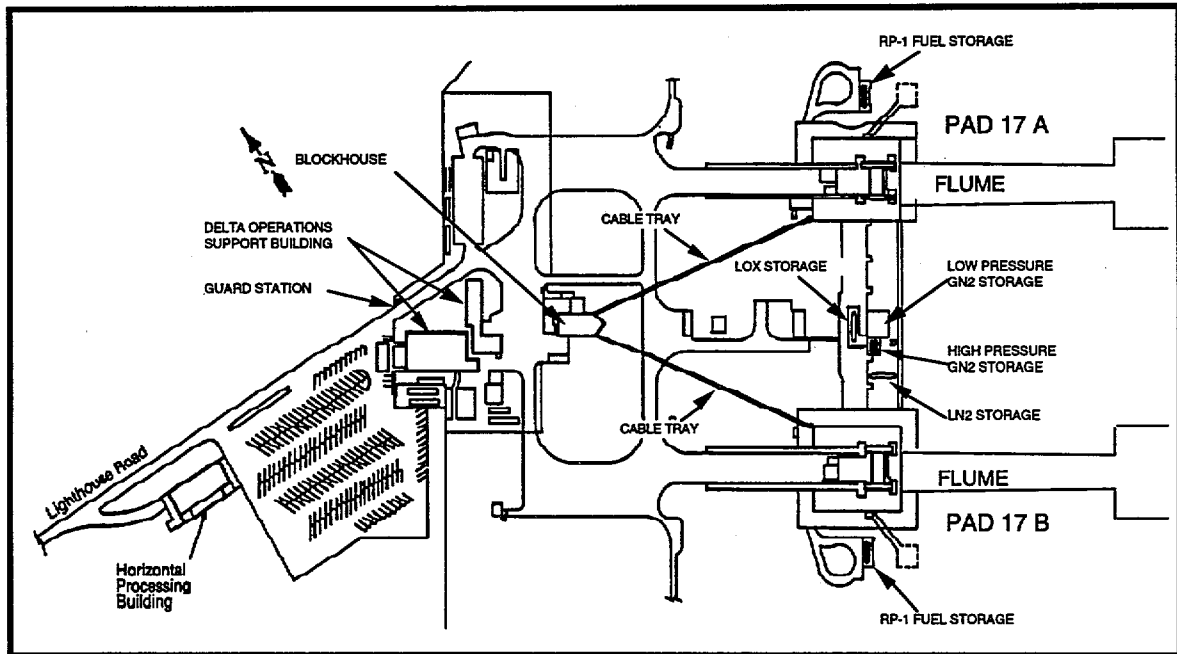

Source: [USAF 1988]

Figure 3-4. Launch Complex 17

3.1.4 Public Facilities and Emergency Services [USAF 1990]

The city of Cocoa provides potable water, drawn from the Floridan Aquifer, to the central portion of Brevard County. The maximum capacity is 152 million liters (40 million gallons) per day, and average daily consumption is about 99 million liters (26 million gallons) per day.

The cities of Cocoa, Cape Canaveral, Cocoa Beach, and Rockledge are each served by their own municipal sewer systems. Unincorporated areas are accommodated by several plants, some of which have reached capacity. Municipal plants in Cape Canaveral, Cocoa Beach, and Cocoa have been expanded and plans are in the works for expansion of the Rockledge system.

Florida Power and Light supplies electricity to Brevard County. Police departments in the five municipalities of the central Brevard area have an average of one officer per 631 people, and fire protection has one full-time officer per 936 people. Health care within the area is available at 28 general hospitals, three psychiatric hospitals, and two specialized hospitals.

Rail transportation for Brevard County is provided by Florida East Coast Railway. A main line traverses the cities of Titusville, Cocoa, and Melbourne, and spur lines provide access to other parts of the county [USAF 1986].

3.1.5 CCAS Facilities and Services

CCAS receives its water supply from the city of Cocoa, and uses roughly 11.4 million liters (3 million gallons) per day. To support launch facility deluge systems, the distribution system at CCAS was constructed to provide up to 114,000 liters (30,000 gallons) per minute for up to ten minutes. [USAF 1990]

The CCAS provides for its own sewage disposal with on-site package sewage treatment plants (STPs). The Complex 17 STP has a capacity of 57,000 liters (15,000 gallons) per day and is permitted by the Florida Department of Environmental Regulation (FDER permit number D005-123750) [USAF 1988].

All solid waste is collected by a contractor and disposed of on the CCAS. The landfill is located approximately 122 meters (400 feet) northeast of the station's airstrip and has a life expectancy of 30 years. Hazardous wastes are accumulated at a number of locations throughout CCAS pending disposal. Wastes are collected for up to 90 days at the satellite stations before transfer to one of three CCAS hazardous waste storage facilities, where they are stored for eventual shipment to a licensed hazardous waste treatment/disposal facility. [USAF 1986]

The Range Contractor conducts all police services on CCAS. A mutual agreement for fire protection services exists between the city of Cape Canaveral, KSC, and the Range Contractor at CCAS. The station is equipped with a dispensary under contract to NASA. The dispensary normally works on a forty-hour week basis. If medical services cannot be provided by the dispensary, hospitals at Patrick Air Force Base (PAFB) and in Cocoa, Titusville, and Melbourne are used. [USAF 1986]

3.1.6 Archeological and Cultural Resources

Within the region, there are 81 sites that are listed in the National Register of Historic Places [DOI 1991], and 2 in the National Register of Historic Landmarks.

In 1982, an archeological/historical survey of CCAS was conducted that consisted of literature and background searches and field surveys. The survey located 32 prehistoric and historic sites and several uninvestigated historic localities. Results of the field survey indicated that many of the archeological resources had been severely damaged by the construction of roads, launch complexes, power lines, drainage ditches, and other excavation. The survey recommended 11 sites for further evaluation to determine eligibility for the National Register of Historic Places. [RAI 1982]

The protection and interpretation of significant resources associated with the space program are underway by the Department of Interior, National Park Service, and USAF, through the Man in Space National Historic Landmark Program. Areas at CCAS designated as landmark sites include the Mission Control Center and launch complexes 5, 6, 13, 14, 19, 26, and 34, which were used during the Mercury and early Gemini manned space flights. [USAF 1988]

3.2 NATURAL ENVIRONMENT

3.2.1 Meteorology and Air Quality

3.2.1.1 Meteorology

The climate of the region is subtropical with two distinct seasons: long, warm, humid summers and short, mild, and dry winters [NASA 1992]. Rainfall amounts vary both seasonally and yearly. Average rainfall is 128 centimeters (51 inches), with about 70 percent falling during the wet season (May to October). Temperature is less variable — prolonged cold spells and heat waves rarely occur. Tropical storms, tropical depressions, and hurricanes occasionally strike the region, generally in the period starting in August and ending in mid-November. The possibility of winds reaching hurricane force in Brevard County in any given year is approximately 1 in 20 [USAF 1986]. Tornadoes may occur, but are very scarce. Hail falls occasionally during thunderstorms, but hailstones are usually small and seldom cause much damage. Snow in the region is rare.

Summer weather typically lasts about nine months of the year, starting in April. Afternoon thundershowers are common and usually result in lower temperatures and an ocean breeze. Occasional cool days occur as early as November, but winter weather generally commences in January and extends through March. [NASA 1986]

The wind rose in Figure 3-5 shows the annual average frequency distribution of average wind speed and direction in the vicinity of CCAS. At CCAS, winds typically come from the north/northwest from December through February, from the southeast from March through May, and from the south from June through August. Sea breeze and land breeze phenomena occur commonly over any given 24-hour period due to unequal heating of the air over the land and ocean. Land breeze (toward the sea) occurs at night when air over land has cooled to a lower temperature than that over the sea; sea breeze (toward the land) occurs during the day when air temperatures over the water are lower. The sea breeze and land breeze phenomena occur frequently during the summer months, less frequently during the winter. [USAF 1986]

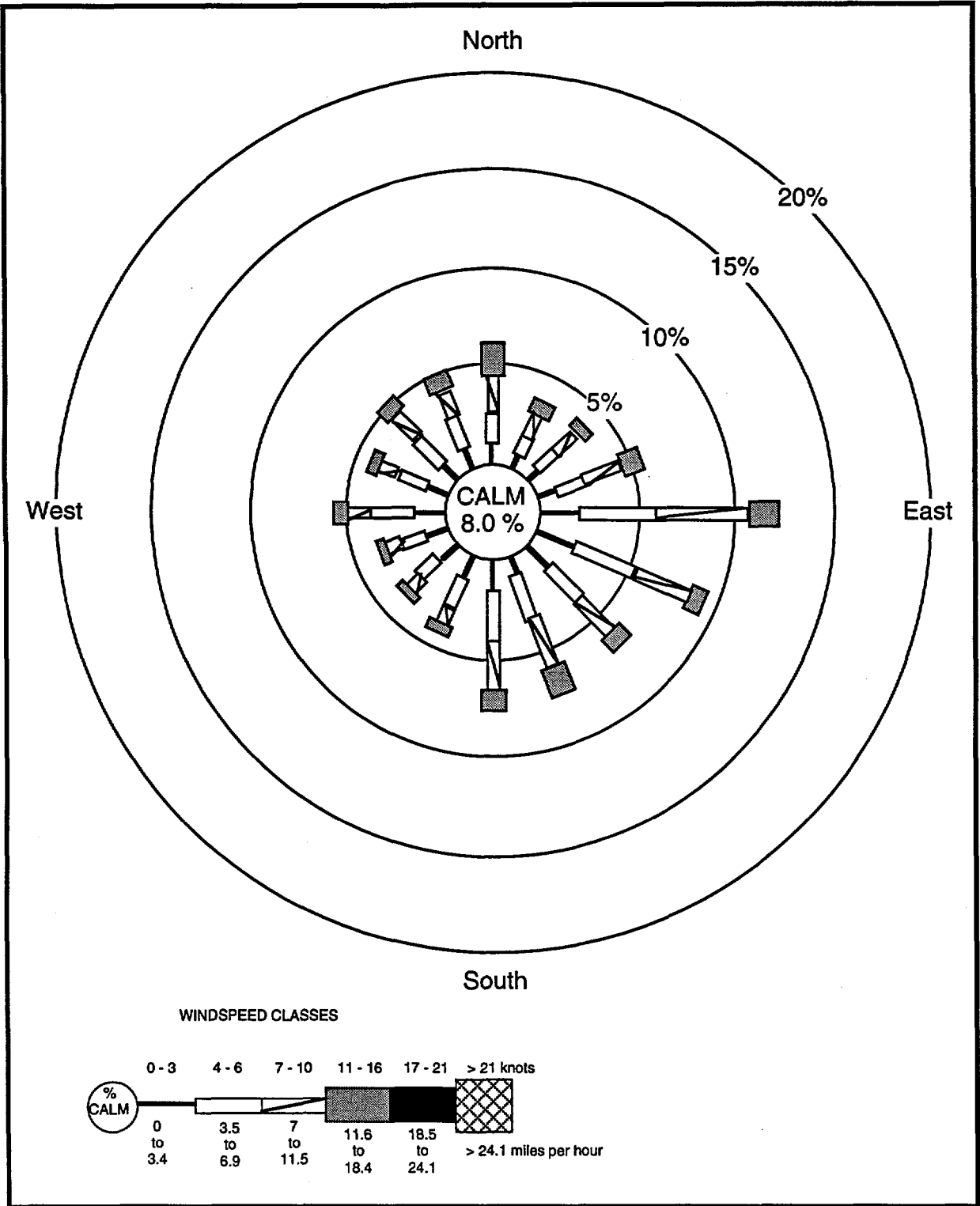

Source: Adapted from [USAF 1988]

Figure 3-5. Wind Rose Indicating Wind Speed and Direction — Lower Atmospheric Conditions: Cape Canaveral 1968 - 1978 Annual Averages

3.2.1.2 Air Quality

Air quality at CCAS is considered good, primarily because of the distance of the station from major sources of pollution. There are no Class I or nonattainment areas for criteria pollutants (ozone [O₃], nitrogen oxides [NO_x], sulfur dioxide [SO₂], lead [Pb], carbon monoxide [CO], and particulates) within about 96 km (60 miles) of CCAS. Orange County was a nonattainment area for ozone until 1987, when it was redesignated as an ozone attainment area. [NASA 1992]

The station and its vicinity are considered to be "in attainment" or "unclassifiable" with respect to National Ambient Air Quality Standards (NAAQS) for criteria pollutants [USAF 1990]. The criteria pollutants and the federal and state standards are listed in Table 3-1. Though NAAQS apply to continuously emitting sources, they will be used for comparative purposes throughout this EA.

The daily air quality at CCAS is chiefly influenced by a combination of vehicle traffic, maintenance activities, utilities fuel combustion, and incinerator operations. Space launches influence air quality only episodically. Two regional power plants are located within 20 km (12 miles) of the station and are believed to be the primary source of occasional elevations in nitrogen dioxide and sulfur dioxide levels. Ozone is CCAS's most consistently elevated pollutant. However, between 1980 and 1990, there have been only six exceedances of ambient air quality of the primary and secondary standards for ozone. [NASA 1992]

3.2.2 Noise

Monitoring of ambient noise levels at CCAS has not been performed. However, it would be expected that noise generated at the station would include sources from day-to-day operations, launches of space vehicles, industrial operations, construction, and vehicular traffic [USAF 1990].

Day-to-day operations at CCAS would most likely approximate that of any urban industrial area, reaching levels of 60 to 80 decibels (dBA), but with a 24-hour average ambient noise level that is somewhat lower than the EPA-recommended upper level of 70 dBA [USAF 1990, NASA 1992].

Launches occur infrequently, but during liftoff launch vehicle rocket engine noise is characterized as intense, composed predominantly of low frequencies, and has a relatively short duration. This noise is usually perceived by the surrounding communities as a distant rumble. Space launches also generate sonic booms during vehicle ascent and stage reentry. Launch-generated sonic booms are directed upward and in front of the

Table 3-1. State and Federal Air Quality Standards

Pollutant	Averaging Time	State of Florida Standard	Federal Primary Standard	Federal Secondary Standard
Carbon Monoxide (CO)	8-hour *	10 mg/m ³ (9 ppm)	10 mg/m ³ (9 ppm)	none
	1-hour *	40 mg/m ³ (35 ppm)	40 mg/m ³ (35 ppm)	none
Lead (Pb)	Quarterly Arithmetic Mean	1.5 µg/m ³	1.5 µg/m ³	same as primary
Nitrogen Dioxide (NO ₂)	Annual Arithmetic Mean	100 µg/m ³ (0.05 ppm)	100 µg/m ³ (0.05 ppm)	same as primary
Ozone (O ₃)	1-hour †	235 µg/m ³ (0.12 ppm)	235 µg/m ³ (0.12 ppm)	same as primary
Sulfur Dioxide (SO ₂)	Annual Arithmetic Mean	60 µg/m ³ (0.02 ppm)	80 µg/m ³ (0.05 ppm)	none
	24-hour *	260 µg/m ³ (0.1 ppm)	365 µg/m ³ (0.14 ppm)	none
	3-hour *	1300 µg/m ³ (0.5 ppm)		1300 µg/m ³ (0.5 ppm)
Total Suspended Particulates (TSP)	Annual Arithmetic Mean	50 µg/m ³ (35 ppm)	50 µg/m ³ (35 ppm)	same as primary
	24-hour *	150 µg/m ³ (35 ppm)	150 µg/m ³ (35 ppm)	same as primary

Source: [NASA 1992]

NOTE: mg/m³ = milligrams per cubic meter
 µg/m³ = micrograms per cubic meter
 ppm = parts per million

* Not to be exceeded more than once per year

† Not to be exceeded an average of more than one day per year

vehicle and occur over the Atlantic Ocean. Stage reentry sonic booms also occur over the open ocean and do not impact developed coastal areas [USAF 1990]. Some launch vehicle related noise levels measured at KSC are shown in Table 3-2.

Peak noise levels created by industrial and construction activities — mechanical equipment such as diesel locomotives, cranes, and rail cars — could range

Table 3-2. Launch Noise Levels at Kennedy Space Center

SOURCE	NOISE LEVEL	REMARKS
Titan IIIC	93.7 dBA	21 October 1965
Saturn I	89.2 dBA	Average of 3 launches
Saturn V	91.0 dBA	15 April 1969
Space Shuttle	89.6 dBA	Estimated

Source: [NASA 1992]

from about 90 to 111 dBA. Vehicular traffic noise ranges from around 85 dBA for a passenger auto to about 100 dBA for a motorcycle. [NASA 1992]

3.2.3 Land Resources

3.2.3.1 Geology

The region is underlain by a series of limestone formations, with a total thickness of several thousand feet. The lower formations contain the Upper Floridan Aquifer, which is under artesian pressure in the vicinity of the station. At CCAS, the Upper Floridan Aquifer commences at a depth of about 80 meters (260 feet) and is about 110 meters (360 feet) thick [USAF 1990]. Beds of sandy clay, shells, and clays of the Hawthorn formation overlay the Floridan Aquifer, isolating the Floridan Aquifer from other, more shallow aquifers. The Hawthorn formation lies at a depth of about 30 meters (100 feet) at CCAS and is about 50 meters (160 feet) thick. Overlying the Hawthorne formation are upper Miocene, Pliocene, Pleistocene, and recent age deposits, which form secondary, semi-confined aquifers and the Surficial Aquifer, which lay at depths up to about 30 meters (100 feet).

CCAS lies on a barrier island composed of relict beach ridges formed by wind and wave action. This island, approximately 7.5 km (4.5 miles) wide at the widest point, parallels the Florida shoreline and separates the Atlantic Ocean from the Indian River, Indian River Lagoon, and Banana River. The land surface elevation ranges from sea level to about 6 meters (20 feet) above sea level at its highest point. LC-17 is located near the southeastern shore of the station. This area is designated as above the 500 year floodplain. [USAF 1990]

3.2.3.2 Soils

Soils on CCAS have been mapped by the U.S. Department of Agriculture Soil Conservation Service (SCS). Soil types that have been identified by the SCS in the vicinity of LC-17 are Canaveral Complex, Palm Beach Sand, Urban Land, and Canaveral-Urban

Land Complex. These native soils are composed of highly permeable, fine-grained sediments typical of beach and dune deposits. Based on examination of well and soil borings from CCAS, the near-surface stratigraphy is fairly uniform, consisting of Pleistocene age sand deposits that underlie the installation to depths of approximately 30 meters (100 feet). [USAF 1988]

3.2.4 Hydrology and Water Quality

3.2.4.1 Surface Waters

The station is located on a barrier island that separates the Banana River from the Atlantic Ocean. As is typical of barrier islands, the drainage divide is the dune line just inland from the ocean. Little runoff is naturally conveyed toward the ocean; most runoff percolates or flows westward toward the Banana River. The majority of storm drainage from CCAS is collected in manmade ditches and canals and is directed toward the Banana River.

Major inland water bodies in the CCAS area are the Indian River, Banana River, and Mosquito Lagoon. These water bodies tend to be shallow except for those areas maintained as part of the Intracoastal Waterway. The Indian and Banana Rivers, which join at Port Canaveral, have a combined area of 60,000 ha (150,000 acres) in Brevard County and an average depth of 1.8 meters (6 feet). This area receives drainage from 216,000 ha (540,000 acres) of surrounding terrain.

Predominant ocean currents in the vicinity of CCAS are north of the area. From the Cape Canaveral region to 26 km (16 miles) offshore, the average ocean current speed is 1.7 to 5 km per hour (1 to 3 miles per hour). Beyond about 26 km, the system of currents becomes known as the Florida Current of the Gulf Stream. The central axis of the Gulf Stream is located approximately 83 km (50 miles) off the coast of Florida at Cape Canaveral.

3.2.4.2 Surface Water Quality

Surface water quality near CCAS and KSC is monitored at 11 long-term monitoring stations that are maintained by NASA. Other monitoring stations in the general area are maintained by Brevard County, the U.S. Fish and Wildlife Service, and the Florida Department of Environmental regulation [NASA 1992]. In general, the water quality in the monitored surface waters has been characterized as good. Both the northern and southern segments of the Banana River tend to be brackish to saline (15 to 36 parts per thousand [ppt]) at NASA Causeway East [USAF 1990]. Water quality monitoring data for the southern segment of the Banana River is summarized in Table 3-3.

Table 3-3. Summary of Water Quality Monitoring Data for South Banana River

Parameter	Average Value	Range of Values	State FDER Class III Standards
Conductivity ($\mu\text{mhos/cm}$)	33,300	12,470 - 50,500	Varies
Total Suspended Solids (mg/l)	32	1 - 143	No standard
Turbidity NTU	2.09	0.76 - 5.0	29 NTU above background
Oil and Grease (mg/l)	0.8	<0.2 - 3.9	≤ 5.0 ; no taste or odor
Phenols ($\mu\text{g/l}$)	128	32 - 364	< 300
Alkalinity (mg/l)	130	109 - 168	≥ 20 (fresh water)
pH	8.6	7.4 - 9.2	6.5 - 8.5 (marine water)
Total Kjeldahl Nitrogen (mg/l)	1.96	0.23 - 15.00	No standard
Nitrate Nitrogen (mg/l)	0.02	<0.02 - 0.06	No standard
Ortho Phosphate (mg/l)	0.032	<0.025 - 0.08	No standard (marine)
Chlorophyll A (mg/m^3)	5.0	<0.5 - 74.7	No standard
Biological Oxygen Demand (mg/l)	2.5	<1 - 7	No standard
Chemical Oxygen Demand (mg/l)	712	478 - 1361	No standard
Dissolved Oxygen (mg/l)	6.6	2.1 - 10.2	≥ 4 mg/l (marine water)
Total Organic Carbons (mg/l)	5.41	2.23 - 13.00	No standard
Aluminum (mg/l)	0.62	< 0.10 - 8.47	≤ 1.5 (marine water)
Cadmium ($\mu\text{g/l}$)	0.56	<0.01 - 2.86	≤ 0.3
Chromium (mg/l)	0.020	<0.001 - 0.05	0.5 (Cr ⁺⁶)
Iron (mg/l)	0.075	<0.040 - 0.178	0.3 (marine water)
Zinc (mg/l)	0.023	< 0.01 - 0.234	86 (fresh water)
Silver ($\mu\text{g/l}$)	17.88	< 0.05 - 31.3	≤ 0.05 (marine water)

Source: [NASA 1992]

NOTE: mg/l = milligram per liter
 $\mu\text{g/l}$ = microgram per liter
 $\mu\text{mhos/cm}$ = micromhos per centimeter

The Banana River is designated a Class III surface water, as described by the Federal Clean Water Act of 1977. Class III standards are intended to maintain a level of water quality suitable for recreation and the production of fish and wildlife communities.

The Banana River is also designated an Outstanding Florida Water (OFW) by the Florida Department of Environmental Regulation. An OFW is provided the highest degree of protection of any Florida surface waters. [NASA 1992]

3.2.4.3 Ground Waters [USAF 1988]

Ground water at the station occurs under both confined (artesian) and unconfined (nonartesian) conditions. Confined ground water is located in the Floridan

Aquifer, which serves as the primary ground water source in the coastal lowlands. Recharge to the Floridan Aquifer occurs primarily in northern and central Florida.

Although good quality water may be obtained from the Floridan Aquifer throughout much of the state, water from this formation on CCAS is highly mineralized and is not used for domestic or commercial purposes. Water for domestic and commercial purposes in this area is generally retrieved from the shallow, unconfined aquifer.

This unconfined surficial aquifer, or water table, is composed of recent and Pleistocene age surface deposits, and is usually found up to 1.5 meters (5 feet) or so below land surface. It is recharged by rainfall along the coastal ridges and dunes. The unconfined aquifer formation at CCAS ranges in depth from about 15 m (50 feet) at the coastal ridge to less than 6 m (20 feet) in the vicinity of the St. Johns River. The unconfined aquifer beneath LC-17 is not used as a water source.

3.2.4.4 Ground Water Quality

Ground water of the Floridan Aquifer at CCAS is not used as a domestic or commercial water source. Table 3-4 summarizes the water quality characteristics of a sample collected from the Floridan Aquifer underlying the west-central portion of the station. The sample exceeded national drinking water standards for sodium, chloride, and total dissolved solids (TDS). [NASA 1992]

Overall, water in the unconfined aquifer in the vicinity of KSC and CCAS is of good quality and meets the State of Florida Class G-II (suitable for potable water use; total dissolved solids less than 10,000 milligrams per liter) and national drinking water quality standards for all parameters, with the exception of iron, and/or total dissolved solids [NASA 1992, USAF 1990]. There are no potable water wells located at Launch Complex 17 or in its vicinity.

Ground water quality in five monitoring wells at LC-17 is generally good, with some detectable quantities of trace metals and organic compounds reported in one well, and detectable zinc concentrations in another [MDC 1990]. These results suggest that soil contaminants detected by earlier studies [USAF 1988] may be relatively non-mobile under the present soil conditions.

3.2.5 Biotic Resources

The station is located in east-central Florida on the Cape Canaveral peninsula. Ecological resources at CCAS are influenced by the Atlantic Ocean on the east and the Banana River on the west. Vegetation communities and related wildlife habitats are representative of barrier island resources of the region. Major community types at CCAS

Table 3-4. Ground Water Quality for the Floridan Aquifer at CCAS

Parameter	Average Value (mg/l)	Drinking Water Standards (mg/l)
Nitrates (as Nitrogen)	< 0.01	10 (primary standard)
Chlorides	540	250 (secondary standard)
Copper	<0.01	1.0 (secondary standard)
Iron	0.02	0.3 (secondary standard)
Manganese	<0.001	0.05 (secondary standard)
Sodium	1400	160 (primary standard)
Sulfate	85	250 (secondary standard)
Total Dissolved Solids	1,425	250 (secondary standard)
pH	7.6	6.5 - 8.5 (secondary standard)
Zinc	<0.01	5.0 (secondary standard)
Arsenic	<0.01	0.05 (primary standard)
Barium	0.02	1.0 (primary standard)
Cadmium	<0.001	0.01 (primary standard)
Chromium	0.001	0.05 (primary standard)
Lead	<0.001	0.05 (primary standard)
Mercury	0.0005	0.002 (primary standard)
Selenium	0.006	0.01 (primary standard)

Source: [USAF 1988]

NOTE: mg/l = milligrams per liter
 primary standard = National Interim Primary Drinking Water Regulations
 secondary standard = National Secondary Drinking Water Regulations

include beach, coastal strand and dunes, coastal scrub, lagoons, brackish marsh, and freshwater systems in the form of canals and borrow pits.

The restrictive nature of CCAS and KSC activities has allowed large areas of land to remain relatively undisturbed. In addition to communities found at CCAS, coastal hammocks and pine flatwoods are found on KSC to the northwest and increase the ecological diversity and richness of the area [USAF 1988]. A majority of the 65 square km (25 square mile) complex consists of coastal scrub, woodland, strand, and dune vegetation. Coastal scrub and coastal woodland provide excellent cover for resident wildlife. Coastal strand occurs immediately inland of the coastal dunes and is composed of dense, woody shrubs. Coastal dune vegetation (a single layer of grass, herbs, and dwarf shrubs) exists from the high tide point to between the primary and secondary dune crest. Wetlands represent only a minor percentage (less than 4 percent) of the total land area and include freshwater marsh, mangrove swamp, and salt swamp. Known hammocks are small, total less than 0.8 square km (0.3 square miles), and are characterized by closed canopies of tree, shrub, and herb vegetation. Most of the

wildlife species resident at the station can be found in each of these vegetation communities. No federally designated threatened or endangered flora are known to exist at CCAS. [USAF 1991]

3.2.5.1 Terrestrial Biota [USAF 1988]

Natural upland vegetation communities found on CCAS are coastal dune, coastal strand, coastal scrub, and hammock. Wetlands found on-site include both marshes and swamps.

The coastal dune community extends from the coastal strand system to the high tide line. Dune systems develop on poorly consolidated, excessively drained sands that are exposed to constant winds and salt spray.

Launch Complex 17 is surrounded by coastal scrub vegetation. The coastal scrub community covers approximately 3,760 ha (9,400 acres), or about 78 percent of the undeveloped land on CCAS. This community is distributed on excessively drained, nutrient-deficient marine sands.

Coastal strand vegetation occurs between the coastal dune and scrub communities and lies just east of LC-17. Coastal strand communities exist on sandy, excessively drained soils dominated by shrubs and often are nearly devoid of ground cover vegetation.

CCAS beaches are nonvegetated, but provide significant wildlife resources. The tidal zone supports a large number of marine invertebrates, as well as small fish that are food for various shorebirds. CCAS and KSC beaches are also important nesting areas for several varieties of sea turtles.

Coastal hammocks are characterized by closed canopies of cabbage palm, the dominant tree species. Hammocks are shaded from intense insolation, and therefore retain higher levels of soil moisture than the previously described habitats. No hammocks occur in the immediate vicinity of LC-17, the nearest one being about 3 km (1.8 miles) west of the site, adjacent to the Banana River.

Wetlands within and surrounding station facilities are important wildlife resources. Wetland types that are found in the area include fresh water ponds and canals, brackish impoundments, tidal lagoons, bays, rivers, vegetated marshes, and mangrove swamps. No marsh or swamp systems occur near LC-17. The nearest wetland environment is a saltwater marsh/swamp on the northwestern shore of Merritt Island, 8.2 km (about 5 miles) north of the launch complex. These soils are not suitable for cultivation, yet do contain swamp plants that support migratory and wading birds. [USAF 1990]

Species of plant and animal life observed or likely to occur on CCAS are listed in [USAF 1988].

3.2.5.2 Aquatic Biota [USAF 1988]

The northern Indian River lagoon ecosystem is a shallow system with limited ocean access, limited tidal flux, and generally mesohaline salinities. The aquatic environment is subject to wide fluctuations in temperature and salinity due to the shallowness of the system.

Sea grasses are present in the Indian River system, generally found in patches in shoal areas less than 1 meter (3 feet) deep and surrounded by open, sandy terrain. Benthic invertebrates found in the northern Indian and Banana Rivers include marine worms, mollusks, and crustaceans, typical of estuarine systems. Epibenthic invertebrates collected from the area included horseshoe crabs, blue crabs, and penaid shrimp.

The area is not considered an important nursery area for commercially important shrimp species. Mosquito Lagoon, north of the complex, has been considered an important shrimp nursery area. Blue crabs were determined to spawn in the area.

Few freshwater fish species inhabit the area. Many of the area's freshwater fish species are believed to have been introduced by man. Primary reasons for the low diversity in fish species are considered to be latitude, climate, low habitat diversity, and limited ocean access.

3.2.5.3 Threatened and Endangered Species

The U.S. Fish and Wildlife Service (FWS), the Florida Game and Fresh Water Fish Commission (FGFWFC), and the Florida Commission on Rare and Endangered Plants and Animals (FCREPA) protect a number of wildlife species listed as endangered or threatened under Federal or State of Florida law. The presence, or potential for occurrence, of such species on CCAS was determined from consultations with FWS, FGFWFC, and CCAS and KSC environmental staff, and from a literature survey. Table 3-5 lists those endangered or threatened species in Brevard County residing or seasonally occurring on CCAS and adjoining waters.

A review of the list indicates that only three species (southeastern kestrel, Florida scrub jay, and eastern indigo snake) potentially occur in the immediate vicinity of Launch Complex 17. Three additional species may occasionally occur in wetlands on CCAS. West Indian manatees, green turtles, ridley turtles, and loggerhead turtles are known to occur in the Banana River, Mosquito Lagoon, and along Atlantic Ocean beaches. The red-cockaded woodpecker is not known to occur in the vicinity of LC-17.

Table 3-5. Listed and Proposed Threatened and Endangered Animal Species and Candidate Animal Species In Brevard County and Their Status On CCAS

SPECIES ^a	STATUS ^b			CAPE CANAVERAL AIR FORCE STATION ^c
	USFWS	FGFWFC	FCREPA	
Atlantic Loggerhead Sea Turtle	I	T	T	Occurs on beach/nests
Green Sea Turtle	E	E	E	Occurs on beach/nests
Leatherback Sea Turtle	E	E	R	Occurs on beach/nests
Kemp's Ridley Sea Turtle	E	E	E	Occurs on beach/no nests
Hawksbill Sea Turtle	E	E	E	Occurs offshore/no nests
Eastern Indigo Snake	T	T	SSC	Resident
American Alligator	T(S/A)	SSC	SSC	Resident
Atlantic Salt Marsh Snake	T	T	E	Not observed
Gopher Tortoise	T	SSC	T	Resident
Florida Scrub Jay	T	T	T	Resident
Wood Stork	E	E	E	Resident
Southern Bald Eagle	E	T	T	Visitor
Piping Plover	E	T	SSC	Visitor
Arctic Peregrine Falcon	T	E	E	Transient
Southeastern Kestrel	- -	T	T	Resident
Bachman's Sparrow	C2	- -	- -	Visitor
Reddish Egret	C2	SSC	R	Visitor
West Indian Manatee	E	E	T	Resident in waters
Southeastern Beach Mouse	T	T	- -	Resident
Finback Whale	E			Offshore waters
Humpback Whale	E			Offshore waters
Right Whale	E			Offshore waters
Sperm Whale	E			Offshore waters
Sei Whale	E			Offshore waters
Florida Mouse	C2	SSC	T	Resident
Round-Tailed Muskrat	C2	- -	SSC	Possible resident

Source: Adapted from [USAF 1990], [NASA 1992]

- NOTES:
- ^a Scientific names of listed species are in [NASA 1992] and [USAF 1990]
 - ^b E = endangered; S/A = similarity of appearance; T = threatened; C2 = proposed for listing as threatened; R = rare; SSC = species of special consideration
 FWS = U.S. Fish and Wildlife Service
 FGFWFC = Florida Game and Fresh Water Fish Commission
 FCREPA = Florida Commission on Rare and Endangered Plants and Animals
 - ^c resident = a species that occurs on CCAS year-round
 visitor = bird species that occurs at CCAS but does not nest there
 transient = bird species that occurs on CCAS only during season of migration
 not observed = species occurs either as a resident or as a visitor in Brevard County but has not been observed on CCAS

SECTION 4

ENVIRONMENTAL IMPACTS OF PROPOSED ACTION AND ALTERNATIVES

The activities associated with completing the preparations of the Pathfinder spacecraft primarily involve refining the spacecraft and mission designs, and spacecraft fabrication, assembly, and component testing at JPL. While such fabrication activities may generate small quantities of effluents normally associated with tooling or cleaning operations, these are well within the scope of normal activities at the fabrication/testing facilities and will produce no substantial adverse environmental consequences.

Pre-launch activities (i.e., those activities occurring at the launch site) would involve integration and testing with the launch vehicle and final launch preparations, such as spacecraft and launch vehicle fueling operations, and would culminate in a successful nominal launch of the Mars Pathfinder spacecraft.

The following sections summarize the environmental effects of a normal Delta II 7925/PAM-D launch and flight, and the effects of possible abnormal spacecraft operations or flight conditions for the launch of the Mars Pathfinder spacecraft.

4.1 ENVIRONMENTAL IMPACTS OF A NORMAL LAUNCH

4.1.1 Air Quality

4.1.1.1 Emissions

Airborne emissions will be generated by prelaunch, launch, and post-launch operations. The majority of emissions will be produced by the graphite epoxy motor solid rockets (9 GEMs on the Delta II 7925 vehicle) and the liquid first stage of the Delta II vehicle during launch. Six of the GEMs and the first stage of the Delta II will be ignited during lift-off. The primary products of GEM combustion will be carbon monoxide (CO), carbon dioxide (CO₂), hydrochloric acid (HCl), aluminum oxide (Al₂O₃) in soluble and insoluble forms, nitrogen oxides (NO_x), and water. Combustion products of the GEM are listed in Table 4-1. Major exhaust products of the Delta II first stage will be CO, CO₂, and water. Exhaust products from the Delta II first stage are given in Table 4-2.

Other emissions resulting from Delta II operations include fuel and oxidant vapors which may escape to the atmosphere during prelaunch or post-launch operations. The first stage of the Delta II uses RP-1 as a fuel and liquid oxygen as an oxidizer. The vehicle's second stage employs Aerozine 50 as a fuel and nitrogen tetroxide (N₂O₄) as an oxidizer. Both stages will be loaded while the vehicle is on the launch pad.

Table 4-1. Combustion Products for the GEM Solid Rocket

Combustion Product	Product Mass Fraction	Product Mass per GEM		Product Mass for 6 Ground-Lit GEMs		Product Mass for 3 Air-Lit GEMs		Total Product Mass for 9 GEMs	
		kg	lbs	kg	lbs	kg	lbs	kg	lbs
AlCl	0.0002	2	5	14	31	7	16	21	47
AlCl ₂	0.0002	2	5	14	31	7	16	21	47
AlCl ₃	0.0001	1	3	7	16	4	8	11	24
AlClO	0.0001	1	3	7	16	4	8	11	24
Al ₂ O ₃ (soluble)	0.2959	3,512	7,727	21,074	46,363	10,537	23,181	31,611	69,544
Al ₂ O ₃ (insoluble)	0.0628	745	1,640	4,473	9,840	2,236	4,920	6,709	14,760
CO	0.2208	2,621	5,766	15,725	34,596	7,863	17,298	23,588	51,894
CO ₂	0.0235	279	614	1,674	3,682	837	1,841	2,511	5,523
Cl	0.0027	32	71	192	423	96	212	288	635
H	0.0002	2	5	14	31	7	16	21	47
HCl	0.2109	2,503	5,507	15,020	33,045	7,510	16,522	22,530	49,567
H ₂	0.0228	271	595	1,624	3,572	812	1,786	2,436	5,359
H ₂ O	0.0773	918	2,019	5,505	12,112	2,753	6,056	8,258	18,168
N ₂	0.0823	977	2,149	5,861	12,895	2,931	6,448	8,792	19,343
OH	0.0002	2	5	14	31	7	16	21	47

Source: Adapted from [MDSSC 1992]

Table 4-2. Exhaust Products for the Delta II 7925 First Stage

Combustion Product	Mass Fraction	Product Mass	
		kilograms	pounds
CO	0.4278	41,173	90,580
CO ₂	0.2972	28,603	62,928
H	0.0001	10	21
H ₂	0.0139	1,338	2,943
H ₂ O	0.2609	25,110	55,242
OH	0.0002	19	42

Source: Adapted from [MDSSC 1992]

RP-1 and liquid oxygen will be loaded into the first stage of the launch vehicle twice during the normal sequence of prelaunch operations. Minor amounts of fuel and oxidizer are loaded approximately two weeks prior to launch to test the fuel system's integrity. Following testing, the tanks will be cleaned, and then loaded to full capacity within several hours before launch. Any fuel spillage that occurs during the loading process is collected in sealed trenches leading from the RP-1 storage tanks to the launch pad, and the RP-1 is then evacuated from these trenches into sealed 55 gallon drums for subsequent disposal by a certified subcontractor. Vapor losses during first stage loading will be minimal, due to the low volatility of RP-1.

Aerozine 50 and N_2O_4 will be loaded into the second stage 3 days prior to the scheduled launch date. Pollution control devices are utilized to control emissions resulting from fuel and oxidizer handling operations. Chemical scrubbers are used to remove pollutants from the vapors; the scrubber solutions are then released into drums for disposal by a certified subcontractor. Spillage of Aerozine 50 or N_2O_4 will be collected in stainless steel tubs under the scrubber units, then collected in drums and disposed of by a certified subcontractor.

Emergency release could occur during the rupture of a part of the propellant loading system, mainly as a result of over pressurization of the system. Redundant flow meters and automatic shutdown devices on the propellant loading system will prevent overfilling of the propellant tanks. Automatic pressure monitoring devices on the tanks and feed system prevent over pressurization.

In the unlikely event of a vehicle destruction on the pad, failure in flight, or a command destruct action, liquid propellant tanks and GEM casings are ruptured. Under these circumstances, most of the released liquid propellants would ignite and burn. Rupture of the GEM casings creates a sudden reduction in chamber pressure, which will extinguish most of the solid propellants; only a portion may continue to burn.

4.1.1.2 Impacts

In a normal launch, exhaust products from the Delta II 7925 (Tables 4-1 and 4-2) are distributed along the launch vehicle's path (Figures 4-1 and 4-2). The quantities of exhaust emitted per unit length of the trajectory are greatest at ground level and decrease continuously. The portion of the exhaust plume that persists longer than a few minutes (the ground cloud) is emitted during the first few seconds of flight and is concentrated near the pad area. Little information has been developed specifically for the Delta vehicle, but data from the Titan program has been used as a basis for comparison [USAF 1988].

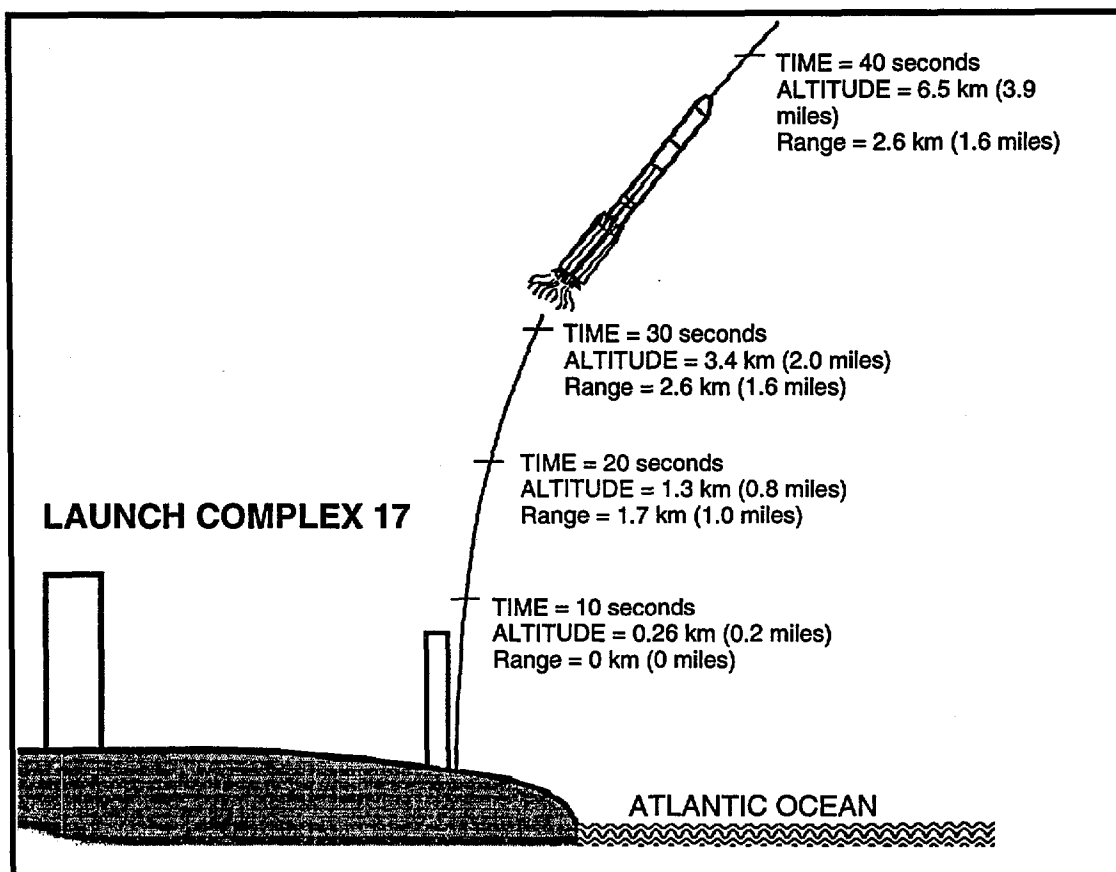

Source: Adapted from [MDA 1993]

Figure 4-1. Delta II 7925 Launch Area Flight Profile

To estimate the peak ground level concentrations of ground cloud pollutants, the U.S. Air Force has extrapolated Delta II exhaust plume diffusion data from models developed for the Titan launch vehicle program. These Titan models are used to calculate peak ground level concentrations of various pollutants in ground clouds. Due to the similarity in propellant types, the Delta vehicle ground cloud will be similar in composition to that produced by the Titan. However, the size of the Delta ground cloud should be considerably smaller than that of the Titan because the Delta vehicle and solid rocket GEMs contain less propellant, produce less vapor, and accelerate off the launch pad more quickly than the Titan. The ground cloud resulting from a normal Delta II launch is predicted to have a radius of about 20 meters (about 67 feet).

From these estimates, HCl concentrations from a Delta II ground cloud should not exceed 5 ppm beyond about 4.3 km (2.7 miles) downwind. The Occupational Health and Safety Administration (OSHA) permissible exposure limit (PEL) for HCl is 5 ppm for an 8-hour time-weighted average. Although National Ambient Air Quality Standards

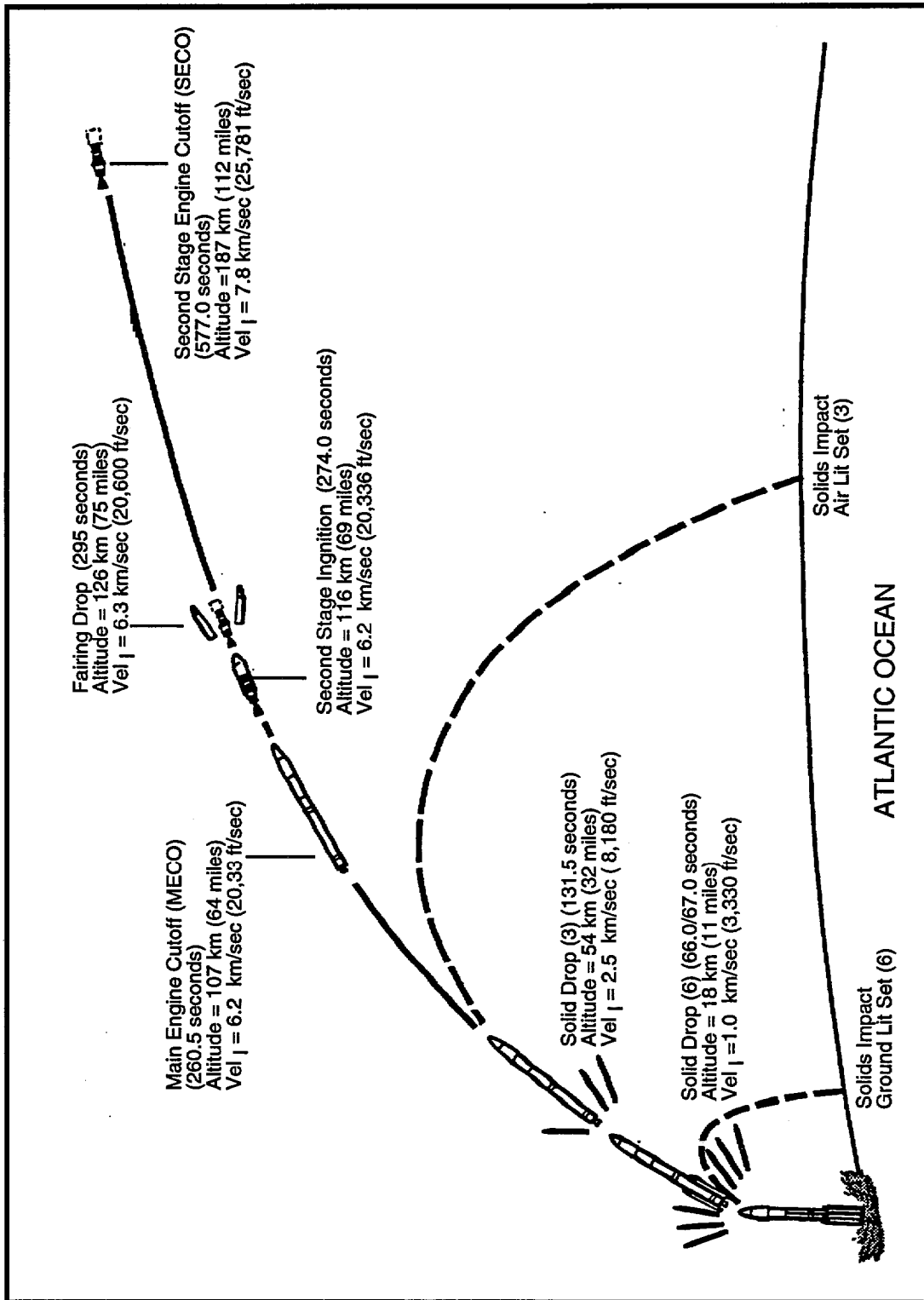

Source: Adapted from [MDA 1993]

Figure 4-2. Delta II 7925 Boost Profile (Up to Orbit Injection)

(NAAQS) have not been adopted for HCl, the National Academy of Sciences (NAS) developed recommended short-term exposure limits for HCl of 20 ppm for a 60-minute exposure, 50 ppm for a 30-minute exposure, and 100 ppm for a 10-minute exposure. Since the nearest uncontrolled area (i.e., general public) is approximately 4.8 km (3 miles) from LC-17, HCl concentrations are not expected to be high enough to be harmful to the general population. The maximum level of HCl expected to reach uncontrolled areas during preparation and launch of the Delta II would be well below the NAS recommended limits. Appropriate safety measures will also be taken to ensure that the permissible exposure limits defined by the Occupational Safety and Health Administration are not exceeded for personnel in the launch area.

The same predictive modeling techniques used for HCl were also applied to CO and Al₂O₃. Carbon monoxide concentrations are not expected to exceed the NAAQS of 35 ppm (1 hr average) beyond the immediate vicinity of the launch complex and are expected to rapidly oxidize to carbon dioxide (CO₂) in the atmosphere. For Titan launches, CO concentrations were predicted to be less than 9 ppm except for brief periods during actual lift-off. Concentrations resulting from a Delta launch should be considerably lower.

Aluminum oxide exists as a crystalline dust in solid rocket motor (SRM) exhaust clouds, but is inert chemically and is not toxic. However, since many of the dust particles are small enough to be retained by lungs, it is appropriate to abide by NAAQS for suspended particulates smaller than 10 microns. For particles smaller than 10 microns, peak concentrations of aluminum oxide should not exceed 11 mg/m³ at a distance of approximately 4.8 km (3 miles) from the launch site [USAF 1990]. The NAAQS for continuous emitters of particulate matter, 150 µg/m³ (24-hour average), should not be exceeded by a Delta II launch due to the short nature of the launch event.

Nitrogen oxides may enter the atmosphere through propellant system venting, a procedure used to maintain proper operating pressures. Air emission control devices will be used to mitigate this small and infrequent pollutant source. First stage propellants will be carefully loaded using a system with redundant spill-prevention safeguards. Aerozine 50 vapors from second stage fuel loading will be processed to a level below analytical detection by a citric acid scrubber. Likewise, N₂O₄ vapors from second stage oxidizer loading will be passed through a sodium hydroxide (NaOH) scrubber. These scrubber wastes will be disposed by a certified hazardous waste contractor according to the CCAS Hazardous Waste Management Plan (OPlan 19-14).

During the last 20 years there has been an increased concern about human activities that are affecting the upper atmosphere. Space vehicles that use SRMs have been studied concerning potential contribution to ozone depletion because of their exhaust products, with the primary depleting component being HCl [USAF 1990].

Extrapolating from estimates made for the Titan IV solid rocket motor upgrade (SRMU) effects on ozone, it is safe to say that the effect on ozone from a Delta II launch would be negligible and indistinguishable from effects caused by other natural and human-made causes.

In addition to the near-pad acidic deposition that could occur during a launch, there is a possibility of acid precipitation from naturally-occurring rain showers falling through the ground cloud. Since the ground cloud for a Delta II launch is very small (about 20.3 m or 67 ft) and concentrates around the launch pad there should be no significant acid rain beyond the near-pad area.

4.1.2 Land Resources

Overall, launching a Delta II vehicle is expected to have negligible negative effects on the land forms surrounding Launch Complex 17 [USAF 1988]. However, launch activities could have some small impacts near the launch pad associated with fire and acidic depositions. Minor brush fires are infrequent by-products of Delta launches, and are contained and limited to the ruderal vegetation within the launch complexes; past singeing has not permanently affected the vegetation near the pads. Wet deposition of HCl, caused by rain falling through the ground cloud or SRM exhaust, could damage or kill vegetation. Wet deposition is not expected to occur outside the pad fence perimeter, due to the small size of the ground cloud and the rapid dissipation of both the ground cloud and SRM exhaust plume [USAF 1990].

4.1.3 Local Hydrology and Water Quality

Water is used at LC-17 for deluge water, launch pad washdown and fire suppressant, and potable water. It is supplied by municipal sources and does not require the withdrawal of ground water. Most of the deluge, washdown, and fire suppressant water is collected in a concrete catchment basin; however, minor amounts may drain directly to grade. The only potential contaminants used on the launch pad are fuel and oxidizer, and the only release of these substances would occur within sealed trenches and should not contaminate runoff. If the catchment basin water meets federal discharge criteria, it is discharged directly to grade at the launch site. If it fails to meet the criteria, it is treated on site and disposed to grade or collected and disposed of by a certified contractor.

The primary surface water impacts from a normal Delta II launch involve HCl and Al₂O₃ deposition from the ground cloud. The cloud will not persist or remain over any location for more than a few minutes. Depending on wind direction, most of the exhaust may drift over the Banana River or the Atlantic Ocean, resulting in a brief acidification of surface waters from HCl. Aluminum oxide is relatively insoluble at the pH of local surface waters and is not expected to cause elevated aluminum levels or

significant acidification of surface waters. The relatively large volume of the two bodies of water compared to the amount of exhaust released is a major factor working to prevent a deep pH drop and associated fish kills. A normal Delta II launch will have no substantial impacts to the local water quality.

4.1.4 Ocean Environment

In a normal launch, the first and second stages and the SRMs will impact the ocean. The trajectories of spent stages and SRMs will be programmed to impact a safe distance from any U.S. coastal area or other land mass. Toxic concentrations of metals are not likely to occur due to the slow rate of corrosion in the deep ocean environment and the large quantity of water available for dilution.

Along with the spent stages will be relatively small amounts of propellant. The release of solid propellants into the water column will be slow, with potentially toxic concentrations occurring only in the immediate vicinity of the propellant. Insoluble fractions of the first stage propellant will spread rapidly to form a localized surface film that will evaporate in several hours. Second stage propellants are soluble and should also disperse rapidly.

Concentrations in excess of the maximum allowable concentration (MAC) of these compounds for marine organisms will be limited to the immediate vicinity of the spent stage. No substantial impacts are expected from the reentry and ocean impact of spent stages, due to the small amount of residual propellants and the large volume of water available for dilution. [USAF 1988].

4.1.5 Biotic Resources

A normal Delta II launch is not expected to substantially impact CCAS terrestrial, wetland, or aquatic biota. The elevated noise levels of launch are of short duration and will not substantially affect wildlife populations. Wildlife encountering the launch-generated ground cloud may experience brief exposure to exhaust particles, but will not experience any significant impacts. Aquatic biota may experience acidified precipitation, if the launch occurs during a rain shower. This impact is expected to be insignificant due to the brevity of the ground cloud and the high buffering ability of the surrounding surface waters to rapidly neutralize excess acidity.

4.1.6 Threatened and Endangered Species

Any action that may affect federally listed species or their critical habitats requires consultation with the U.S. Fish and Wildlife Service (FWS) under Section 7 of the Endangered Species Act of 1973 (as amended). The U.S. FWS has reviewed the actions which would be associated with a Delta II launch from LC-17 and has determined that

those actions would have no effect on state or federally listed threatened (or proposed for listing as threatened) or endangered species residing on CCAS and adjoining waters [USAF 1988], [NASA 1992].

4.1.7 Developed Environment

4.1.7.1 Population and Socioeconomics

Launching the Pathfinder mission will have a negligible impact on local communities, since no additional permanent personnel are expected beyond the current CCAS staff. Launch Complex 17 has been used exclusively for space launches since the late 1950s. The Pathfinder mission will cause no additional adverse impacts on community facilities, services, or existing land uses.

4.1.7.2 Safety and Noise Pollution

The "Medium Launch Vehicle Accident Risk Assessment Report" [MDSSC 1986] describes the launch safety aspects of the Delta II vehicle, support equipment, and LC-17 facilities. The report identifies design and operating limits that will be imposed on system elements to preclude or minimize accidents resulting in damage or injury. Normal operations at CCAS include preventative health measures for workers such as hearing protection, respiratory protection, and exclusion zones to minimize or prevent exposure to harmful noise levels or hazardous areas or materials.

The engine noise and sonic booms from a Delta II launch are typical of routine CCAS operations. To the surrounding community, noise from launch-related activity appears, at worst, to be an infrequent nuisance rather than a health hazard. In the history of the USAF space-launch vehicle operations from CCAS, there have been no problems reported as a result of sonic booms, most probably because the ascent track of all vehicles and the planned reentry of spent suborbital stages are over open ocean, thus placing sonic booms away from land areas. Shipping in the area likely to be affected is warned of the impending launches as a matter of routine, so that all sonic booms are expected and of no practical consequence [USAF 1988].

4.1.7.3 Archaeological and Cultural Resources

Since no surface or subsurface areas will be disturbed, no significant archaeological, historic, or cultural sites are expected to be affected by launching the Pathfinder spacecraft.

4.2 ACCIDENTS AND LAUNCH FAILURES

4.2.1 Liquid Propellant Spill

The potential for an accidental release of liquid propellants will be minimized by strict adherence to established safety procedures. First stage propellants, RP-1 and liquid oxygen, will be stored in tanks near the launch pad within cement containment basins designed to retain 110% of the storage tank volumes. Post-fueling spills from the launch vehicle will be channeled into a sealed concrete catchment basin and disposed of according to the appropriate state and federal regulations. Second stage propellants, Aerozine 50 and N_2O_4 , are not stored at LC-17 and will be transported to the launch site by specialized vehicles.

The most severe propellant spill accident scenario would be releasing the entire launch vehicle load of N_2O_4 at the launch pad while conducting propellant transfer operations. This scenario would have the greatest potential impact on local air quality. Using again the Titan predictive models and scaling for the Delta propellant loading, airborne NO_x levels from this scenario should be reduced to 5 ppm within about 150 m (about 500 feet) and to 1 ppm within 300 m (about 1,000 feet). Activating the launch pad water deluge system would substantially reduce the evaporation rate, limiting exposure concentrations in the vicinity of the spill that are above federally established standards. Propellant transfer personnel will be outfitted with protective clothing and breathing equipment. Personnel not involved in transfer operations will be excluded from the area during such operations.

4.2.2 Launch Failures

4.2.2.1 Non-Radiological Impacts

In the unlikely event of a launch vehicle destruction, either on the pad or in-flight, the liquid propellant tanks and SRM cases would be ruptured. Due to their hypergolic (ignite on contact) nature, a launch failure would result in a spontaneous burning of most of the liquid propellants, and a somewhat slower burning of SRM propellant fragments. Tables 4-3 and 4-4 define the combustion products of a GEM SRM failure and a catastrophic launch pad failure. This release of pollutants would have only a short-term impact on the environment near LC-17.

Launch failure impacts on water quality would stem from unburned liquid propellant being released into CCAS surface waters. For most launch failures, propellant release into surface waters will be substantially less than the full fuel load, primarily due to the reliability of the vehicle destruct system.

Table 4-3. Combustion Products for Delta II 7925 GEM Failure Scenario

Combustion Product	Product Mass Fraction	Total Propellant Mass of 105,872 kg	
		kg	lb
Al ₂ O ₃	0.1759	18,623	40,971
Ar	0.0064	678	1,492
C	0.0143	1,514	3,331
CH ₄	0.0000	0	0
CO ₂	0.1329	14,070	30,954
Cl ₂	0.0000	0	0
HCl	0.1071	11,339	24,946
H ₂ O (liquid)	0.1274	13,488	29,674
H ₂ O (gaseous)	0.0136	1,440	3,168
N ₂	0.4188	44,339	97,546
O ₂	0.0000	0	0

Source: Adapted from [MDSSC 1992]

Table 4-4. Combustion Products for Delta II 7925 Catastrophic Failure Scenario

Combustion Product	Product Mass Fraction	Total Propellant Mass of 209,433 kg	
		kg	lb
Al ₂ O ₃	0.0926	19,393	42,666
Ar	0.0064	1,340	2,949
C	0.0191	4,000	8,800
CO ₂	0.2514	52,651	115,833
Cl ₂	0.0000	0	0
HCl	0.0551	11,540	25,387
H ₂ O (liquid)	0.1556	32,588	71,693
H ₂ O (gaseous)	0.0141	2,953	6,497
N ₂	0.4051	84,841	186,651
O ₂	0.0000	0	0

Source: Adapted from [MDSSC 1992]

If there was an early flight termination and failure of the vehicle destruct system, it is remotely possible that the entire stage 2 propellant quantity could be released to the ocean. Shallow or confined surface water systems would receive most of the impact. The release of the entire RP-1 fuel load in this near-pad intact vehicle impact scenario would form a very thin film (less than 0.003 cm, or 0.001 inches) covering a water surface area less than 4.4 square km (1.7 square miles). This film would be expected to dissipate within a few hours. In this hypothesized worst case, which has never occurred for the Delta II, Aerozine 50 and N₂O₄ contaminants could exceed allowable concentrations for an approximate radius of 241 m (800 ft) in water depths exceeding 3 m (9 ft) deep. However, even given this worst case scenario, the impacts to ocean systems would be localized and/or transient in nature, and expected to recover rapidly. [USAF 1988]

4.2.2.2 Radiological Impacts

4.2.2.2.1 Impacts Due To LWRHUs

The information in this subsection is summarized from a safety assessment of the LWRHUs for the Mars Pathfinder Mission [DOE 1993]. An additional accident scenario, powered reentry of the spacecraft, has been added to this discussion, although not specifically treated in the Pathfinder LWRHU safety assessment document. Powered reentry will be addressed in the Pathfinder Safety Analysis Report, to be completed in 1995. In summary, based upon the LWRHU Mars Pathfinder Safety Assessment comparisons to the tests and analytical studies performed on LWRHUs for the Galileo Mission (which had 120 LWRHUs on the orbiter and probe), no release of the plutonium heat source is expected for any of the defined accident scenarios.

Table 4-5 lists the 21 identified accident scenarios considered in the Safety Assessment. Categorized as either prelaunch, launch, early flight, or late flight accidents, each of these accident scenarios would entail one or more of the following environments. (The environments and expected LWRHU responses described below are based on comparisons to the tests and analyses completed for the Galileo LWRHUs.)

4.2.2.2.1.1 Explosions/Fireball

Environment: The fireball resulting from an explosion of the Delta vehicle during launch, assuming complete liquid propellant mixing, would have a diameter of 157 m (515 feet), a temperature of 2300 K (2027° C, 3680° F), and a duration of 14 seconds.

Response: Since no explosion environments near the LWRHUs were identified for the launch vehicle, no clad failures or plutonium releases are expected.

Table 4-5. Accident Scenarios Considered in the Safety Assessment

Mission Phase	Accident Scenario
Pre-Launch ($T < 0$ s)	Premature ignition of solid rocket motor
	Explosion during liquid fuel loading
	Premature ordnance activation
	Structural damage
Launch (0 s $< T < 5$ s)	Explosion of liquid rocket engine
	Burn-through or explosion of solid rocket motor
	Solid rocket motor(s) fail to ignite
	Liquid rocket motor hard over at ignition
	Impact with tower
	Premature separation of solid rocket motor(s)
	Loss of thrust after SRM ignition
	Structural failure
	Premature/inadvertent activation of command destruct system (CDS) early flight
Early Flight (5 s $< T < 265$ s)	Activation of command destruct system
	Premature first stage thrust termination
	Loss of burn phase attitude control without CDS action
Late Flight (265 s $< T < 3,669$ s)	Activation of CDS
	Failure of second stage thrust without CDS action
	Failure of separation system
	Premature second stage thrust termination without CDS action
	Loss of second stage attitude control with CDS action

Source: Adapted from [DOE 1993]

4.2.2.2.1.2 Solid Rocket Motor (SRM) Fuel Fire

Environment: There is a possibility during this type of accident that an LWRHU could be in the vicinity of a block of burning SRM fuel. It is assumed that the flame temperature is about 2330 K (2057° C, 3734° F) and would last for about 120 seconds.

Response: The possible fireball environment of the Mars Pathfinder launch was compared to those for the Galileo launch. It is expected for the Pathfinder launch, that the thermal protection afforded by the pyrolytic insulators will keep the clad temperature low enough to ensure containment [DOE 1993]. The solid fuel fire is assumed to be of the same material, but the smaller pieces that would result would produce a shorter duration

fire than in a similar Galileo accident. Therefore, at the aeroshell level, it is expected that there will be no failure of plutonium heat source containment, and no clad failure/plutonium release in the event of fireball exposure.

4.2.2.2.1.3 Fragments

Environment: Due to the geometry of the launch assembly with the payload shielded from all but the third stage debris, only the fragments from the third stage will be considered a threat to the LWRHUs. The maximum velocity of any component is 98 m/s (218 mph), which would occur on the launch pad since debris generated by the third stage later in launch has decreasingly lower velocities.

Response: Tests for Galileo suggested that titanium slugs could deform clads and produce failure if slug velocity was in excess of 775 m/s (1,729 mph). Therefore, the SRM case plates of Ti/6Al/4V with maximum velocities of just under 100 m/s (223 mph) are not expected to fail the clad or release any plutonium dioxide fuel. In the unlikely event of an on-pad abort, it is possible for an LWRHU to be struck by a small titanium fragment from the third stage SRM, then fall to the ground and land next to a block of burning SRM fuel. This accident would likely result in damage to the graphitics but no plutonium release is expected.

4.2.2.2.1.4 Other

Environments: Conditions such as reentry, impact, and soil burial are not expected to differ from those tested or analyzed in support of the Galileo mission. The Mars Pathfinder launch will not entail an Earth swingby and therefore there is no chance for a high-energy reentry. There is a low probability of a misdirected burn of the PAM-D upper stage at the point of trajectory insertion which could result in a powered reentry of the spacecraft.

Response due to Reentry: If the worst case orbital reentry occurs (velocity not greater than 7,926 m/s [26,000 fps]), there will be no clad failures and no significant degradation in clad performance in the impact environment which occurs after an unplanned reentry.

Response due to Powered Reentry: The worst case powered reentry from a high elliptical orbit would result in a reentry velocity estimated to be not greater than 11,890 m/s (39,000 fps) [MDA 1994a]. This velocity is lower than those examined for the Galileo LWRHU FSAR [DOE 1988], therefore no release of the plutonium heat source would be expected.

Response due to Impact: Clad impacts at various orientations were tested for the Galileo mission, and no clad failures were noted. Since there are no differences in possible orbital reentry impacts, no clad failure and no plutonium release is expected.

Response due to Soil Burial: Assuming the poorest soil thermal conductivity, the clad temperature only reached 460 K (187° C or 368° F). The lifetime of the cladding at this temperature would be longer than one could reliably predict, certainly many half-lives of the plutonium. Therefore, there would be no clad failure nor plutonium release expected from soil burial of an LWRHU.

4.2.2.2 Impacts Due to APX Spectrometer

The first space flight of an APX spectrometer was on the Surveyor missions to the Moon during the late 1960s. Because of the limited activity of the Cm-244 source in this instrument (about 2.78 GBq, or 75 millicuries), a single instrument measurement requires direct, undisturbed surface contact with the Cm-244 source for at least ten hours.

Due to the nature of the APXS source, an accident which subjects the spacecraft to any of the environments described in section 4.2.2.1 will likely cause a release of the Curium-244. However, the potential health effects associated with such a release are extremely low. Initial estimates using dose assessment factors developed for Pu-238 in the Ulysses Safety Evaluation Report [INSRP 1990] indicate a conservative incremental increase in latent cancer fatalities of approximately 0.001 over a fifty year period. When considered in light of the probability of a launch failure that could cause a release (most likely event less than 0.002 [MDA 1994b]), the risk of an adverse health effect due to the Cm-244 is less than 3×10^{-6} , or less than 3 in one million. In comparison the naturally occurring cancer incidence rate is about 20% (about 1 in 5) worldwide [ACS 1994].

4.2.2.3 Summary

There are no accident scenarios/environments identified that would result in the release of plutonium from the Rover LWRHUs for a launch of the Mars Pathfinder spacecraft via the Delta II 7925/PAM-D launch system. While accident environments would cause the release of the curium used on the APXS, the amount of curium is small, and the associated incremental risk is negligible.

SECTION 5 REGULATORY REVIEW

5.1 AIR QUALITY

The Florida Department of Environmental Regulation (FDER) regulates air pollutant emission sources in Florida and requires permits for the construction, modification, or operation of potential air pollution sources [FDER 1986]. Emissions from mobile sources, such as aircraft and space launch vehicles, do not require a permit. This exception does not include support facilities such as propellant loading systems.

Stationary, ground-based sources associated with space vehicle launches are subject to FDER review. Because no new stationary sources will be constructed for the Mars Pathfinder launch, there is no requirement for new air quality permits.

The Delta II oxidizer and fuel vapor air pollution control devices at CCAS are in compliance with FDER and National Ambient Air Quality Standards (NAAQS) regulations. The citric acid scrubber for Delta II propellants is probably one level of control beyond that required by the FDER.

5.2 WATER QUALITY

5.2.1 Stormwater Discharge

Florida's stormwater discharge permitting program is designed to prevent adverse effects on surface water quality from runoff. A discharge permit will not be required for Pathfinder because the launch would not increase stormwater runoff rates or reduce the quality of the existing runoff.

5.2.2 Sanitary and Industrial Wastewater Discharge

LC-17 and the Pathfinder spacecraft and launch vehicle assembly facilities have potable water and sanitary waste disposal permits. No new permits will be required for the Pathfinder assembly or launch.

Wastewater from LC-17 will include deluge and washdown water discharged during Pathfinder launch activities. An application has been filed with the FDER to permit discharge from LC-17. The permit will be issued based on demonstration that discharge would not significantly degrade surface water or ground water.

5.2.3 Floodplains and Wetlands

LC-17 is not located on a floodplain. Impacts to wetlands from the launch of the Pathfinder would not exacerbate impacts from other CCAS activities or launches. Therefore, no new permits will be required for the Pathfinder launch.

5.3 HAZARDOUS WASTES

CCAS was issued a Resource Conservation and Recovery Act, Part B Hazardous Waste Operations permit in January 1986 [USAF 1986]. All hazardous wastes generated at CCAS will be managed according to the CCAS Hazardous Waste Management Plan (OPlan 19-14). Hazardous wastes produced during processing and launch operations will be collected and stored in hazardous waste accumulation areas before being transferred to a hazardous storage area. These wastes will eventually be transported to an off-station licensed hazardous waste treatment/disposal facility.

5.4 SPILL PREVENTION

To prevent oil or petroleum discharges into U.S. waters, a Spills Prevention, Control, and Countermeasures Plan (SPCCP) is required by the Environmental Protection Agency's Oil Pollution Prevention Regulation. A SPCCP has been integrated into the CCAS Oil and Hazardous Substance Pollution Contingency Plan (OPlan 19-01). Spills of oil or petroleum products that are federally listed hazardous materials will be collected and removed for proper disposal by a certified contractor according to Cape Canaveral Air Station (CCAS) OPlan 19-4, Hazardous Substance Pollution Contingency Plan [USAF 1990].

5.5 COASTAL MANAGEMENT PROGRAM

The Federal Coastal Zone Management Act of 1972 established a national policy to preserve, protect, develop, restore, and/or enhance the resources of the nation's coastal zone. The Act requires federal agencies that conduct or support activities directly affecting the coastal zone, to perform these activities in a manner that is, to the maximum extent practicable, consistent with approved state coastal zone management programs.

Delta II launches from LC-17 have been demonstrated to be consistent to the maximum extent practical with the State of Florida's Coastal Management Program, based on compatible land use, absence of significant environmental impacts and compliance with applicable regulations [USAF 1986]. Pathfinder mission processing and launch would add no substantial impact beyond those determined to be associated with the Delta II.

5.6 ARCHAEOLOGICAL AND CULTURAL RESOURCES

In accordance with 36 CFR Part 800, the Florida Department of State, Division of Historical Resources, has reviewed the planned Pathfinder launch for possible impact to archaeological and historical sites or properties listed, or eligible for listing, in the National Register of Historic Places. Their review indicates no significant archaeological or historical sites are recorded in the Florida Master Site File, nor are likely to appear there. They consider it unlikely that any such sites would be affected by the proposed action.

[FLORIDA 1993]

NASA has also determined that the proposed action will have no effect on property listed, or eligible for listing, in the National Register of Historic Places.

5.7 CORRESPONDENCE WITH FEDERAL AGENCIES

5.7.1 United States Environmental Protection Agency
(No response received)

5.8 CORRESPONDENCE WITH STATE AGENCIES

5.8.1 Florida State Clearinghouse
(response included in Appendix A)

SECTION 6
REFERENCES

- ACS 1994 American Cancer Society, *Cancer Facts and Figures - 1994*, Atlanta, GA, 1994.
- DOE 1988 United States Department of Energy, Johnson, Ernest W., *Light Weight Radioisotope Heater Unit Final Safety Analysis Report (LWRHU-FSAR), Volume 1B, Reference Design Document (RDD)*, EG&G Mound Applied Technologies, MLM-3540, October 1988.
- DOE 1993 United States Department of Energy, Johnson, Ernest W., *LWRHU MESUR Pathfinder Safety Assessment*, LAI-EGG-93-004, EG&G Mound Applied Technologies, September 30, 1993.
- DOI 1991 United States Department of the Interior, *National register of historic Places, Florida Index*. National Park Service, Washington, DC, July 25, 1991.
- DOT 1986 United States Department of Transportation, *Programmatic Environmental Assessment of Commercial Expendable Launch Vehicle Programs*, February 1986.
- ECFRPC 1992 East Central Florida Regional Planning Council. *East Central Florida Comprehensive Regional Policy Plan*. Winter Park, Florida, February 1992.
- FDER 1986 Florida Department of Environmental Regulation, Florida Administrative Code, *Air Pollution Sources*, Chapter 17-2, October 1986.
- FLORIDA 1993 Florida Department of State Division of Historical Resources response to Florida State Clearinghouse, July, 1993.
- INSRP 1990 Interagency Nuclear Safety Review Panel. *Safety Evaluation Report for Ulysses*. INSRP 90-01, September 1990.
- JPL 1993a Jet Propulsion Laboratory, Pathfinder Project Mission Plan (D-11355, Preliminary), December 1993.
- JPL 1993b Jet Propulsion Laboratory, *Expendable Launch Vehicles Summary for JPL Mission Planning* (D-6936, Rev. C), February 1993.
- MDA 1993 McDonnell Douglas Aerospace, *Launch Vehicle Data to Support the MESUR Pathfinder Environmental Assessment* (MDC 93H0078), July 1993.

- MDA 1994a Data FAX communication from J. Winchell, McDonnell Douglas Aerospace to E. Johnson, Lamb Associates. Regarding Pathfinder reentry modes. February 2, 1994.
- MDA 1994b McDonnell Douglas Aerospace, *Delta II Launch Vehicle Data for MESUR Environmental Assessment* (H41910), March 11, 1994.
- MDC 1990 McDonnell Douglas Corporation, *Ground Water Assessment Report for Launch Complex 17, Cape Canaveral Air Force Station, Brevard County, Florida*, Prepared for MDC by Post, Buckley, Schuh, and Jernigan, Inc., November 1986.
- MDSSC 1986 McDonnell Douglas Space Systems Company, *Medium Launch Vehicle Accident Risk Assessment Report* (Contract No. F04701-86-C-0117), 1986.
- MDSSC 1991 McDonnell Douglas Space Systems Company, *Generic Delta II Missile System Prelaunch Safety Package* (MDC H5455A), 1991.
- MDSSC 1992 McDonnell-Douglas Space Systems Company, *Environmental Impact Statement of the Delta II 7925 Vehicle* (MDC 92H0952), September 1992.
- MMSLS 1991 Martin Marietta Space Launch Systems, *Titan IV CRAF/Cassini EIS Databook (Rev: Basic, MCR-91-2580)*, December 1991.
- NASA 1986 National Aeronautics and Space Administration, *Environmental Resources Document, Kennedy Space Center, KSC-DF-3080*. Prepared for NASA by Edward E. Clark Engineers-Scientists, Inc., November 1986.
- NASA 1990 National Aeronautics and Space Administration, *Final Environmental Impact Statement for the Ulysses Mission (Tier 2)*, June 1990.
- NASA 1992 National Aeronautics and Space Administration, *Environmental Resources Document, Kennedy Space Center, KSC-DF-3080*. Prepared for NASA by Edward E. Clark Engineers-Scientists, Inc., March 1992.
- NASA 1993 National Aeronautics and Space Administration, *KSC Ionizing Radiation Protection Program*, KSC Handbook (KHB) 1860.1B, March 1993.
- NASA 1994a National Aeronautics and Space Administration, *Expendable Launch Vehicle Mars Pathfinder Launch Site Support Plan*, KSC Document K-PSM-11.05, Baseline Issue Revision A, January 1994.
- RAI 1982 Resource Analysts Inc., *Archaeological Resource Survey, Kennedy Space Center and Cape Canaveral Air Force Station*, 1982.

- UOC 1994 Personal communication from T. Economou, University of Chicago, Enrico Fermi Institute to M. Phillips, Jet Propulsion Laboratory. Regarding APX Curium Alpha Sources. March 16, 1994
- USAF 1983 United States Air Force, *Radiation Protection Program, ESMCR 160-1*, Cape Canaveral Air Force Station, August, 1983.
- USAF 1986 United States Air Force, *Environmental Impact Analysis Process, Environmental Assessment Complementary Expendable Launch Vehicle*, Cape Canaveral Air Force Station, Florida, 1986.
- USAF 1988 United States Air Force, *Environmental Assessment: Air Force, Space Division, Medium Launch Vehicle (MLV) Program*, Cape Canaveral Air Force Base, Florida (Environmental Science and Engineering, Inc.), May 1988.
- USAF 1990 United States Air Force, *Environmental Assessment, Titan IV/Solid Rocket Motor Upgrade Program*, Cape Canaveral Air Force Station, Florida (Vandenberg Air Force Base, California), February 1990.
- USAF 1991 United States Air Force, *Environmental Assessment, Delta Centralized Facility*, Cape Canaveral Air Force Base, Florida (Engineering-Science, Inc., June 1991.

APPENDIX A
CORRESPONDENCE WITH STATE AND FEDERAL AGENCIES

NOTE:

Where no agency written response is provided in this appendix, none was received.



National Aeronautics and
Space Administration

Washington, D.C.
20546

*copy for
Mary R
JUN 18/93*

JUN 21 1993

SLB

Reply to Attn of:

To Concerned Agencies and Organizations:

The National Aeronautics and Space Administration (NASA) is seeking approval for plans to launch the Mars Environmental Survey (MESUR) Pathfinder spacecraft on a mission to the surface of Mars. Baseline mission plans call for the spacecraft to be launched during the November-December 1996 opportunity from the Eastern Test Range at the Cape Canaveral Air Force Station, Florida. In accordance with regulations of NASA and the National Environmental Protection Act (NEPA), NASA is conducting an environmental assessment to evaluate any payload-specific environmental impacts.

MESUR Pathfinder is part of NASA's Solar System Exploration Program and is designed to gather important scientific as well as engineering data critical to future Mars missions. The spacecraft will consist of a solar-powered lander carrying three scientific instruments and a small robotic roving vehicle. The rover will carry one scientific instrument and will be battery-powered. The rover may also be equipped with two radioisotope heater units (RHUs) for thermal control. Baseline plans call for launch of the spacecraft payload to low parking orbit aboard a Delta II 7925 launch vehicle. A solid propellant Payload Assist Module-Delta upper stage will then ignite to place the spacecraft onto a trajectory to Mars.

Pre-launch spacecraft testing and loading operations will occur at NASA's Kennedy Space Center and the Cape Canaveral Air Force Station (CCAFS), Cape Canaveral, Florida. After processing, the spacecraft will be transferred to the CCAFS Launch Complex 17 for mating with the launch vehicle. No requirements for new or modified Government or contractor facilities have been identified, and no new facilities or modifications are planned for the mission.

The Pathfinder environmental assessment will address the planned Federal action of integrating the spacecraft with its launch vehicle and launching it onto an interplanetary trajectory. Options to be discussed include alternative launch vehicles, alternatives to RHUs, and the no-action alternative.

2

The primary environmental impacts expected are those associated with the launch vehicle, which are discussed in U.S. Department of the Air Force, Headquarters Space Division, *Environmental Assessment: Air Force, Space Division, Medium Launch Vehicle Program, Cape Canaveral Air Force Base, Florida*, (Environmental Science and Engineering, Inc., Gainesville, Florida, May 1988). Those effects include the impact of rocket fuel combustion products on the quality of air, water, land and wetland, biotic resources, and historical sites. Ongoing activities to monitor or protect endangered and protected species from the effects of a Delta II launch will be described. In addition, in the unlikely event of an accident, there is a remote chance that some fraction of 5.2 gm of plutonium dioxide could be released from the RHUs. Other topics to be addressed in the environmental assessment are safety concerns and socioeconomic impacts. The environmental assessment is expected to be released for public review and comment in November 1993.

Any comments you may presently have should be sent to me within 30 days of the date of this letter, at NASA Headquarters, Code SL, 300 E. Steet SW, Washington, DC 20546. If you need further information, please contact Mr. Kenneth Kumor at NASA Headquarters at (202) 358-1112.

Sincerely,

William L. Piotrowski
William L. Piotrowski
Director, (Acting)
Solar System Exploration Division
Office of Space Science

Distribution:

SL/Dr. W. Piotrowski
 Mr. D. Stetson
JX/Mr. K. Kumor
JPL/Ms.S. Dawson
Florida State Clearing House/Ms. J. Alcott
EPA/Federal Facilities Branch
St. Johns River Water Management District/Ms. J. Unger
U.S. Fish and Wildlife Service/Mr. D. Wesley
Merritt Island Nat'l Wildlife Refuge/Mr. A. R. Hight
Canaveral Nat'l Seashore/Mr. W. Simpson
Patrick AFB/Mr. O. Miller



LAWTON CHILES
GOVERNOR

STATE OF FLORIDA

Office of the Governor

THE CAPITOL
TALLAHASSEE, FLORIDA 32399-0001

Kicga

August 13, 1993

Mr. William L. Piotrowski
Acting Director
Solar System Exploration Division
Office of Space Science
NASA Headquarters
Code SL
300 East Street, Southwest
Washington, DC 20546

RE: Proposed Plan to Launch the Mars Environmental Survey (MESUR) Pathfinder
Spacecraft on a Mission to the Surface of Mars

SAI: FL9306250927C

Dear Mr. Piotrowski:

The Florida State Clearinghouse is awaiting additional comments from our reviewing environmental agencies, therefore, we are requesting an additional fifteen (15) days for completion of the consistency review in accordance with 15 CFR 930.41 (b).

We will make every effort to conclude the review and forward comments to you on or before August 24, 1993.

Sincerely,

A handwritten signature in cursive script that reads "Janice L. Hatter".

Janice L. Hatter
State Clearinghouse

JLH/bl

KioyaLAWTON CHILES
GOVERNORSTATE OF FLORIDA
Office of the GovernorTHE CAPITOL
TALLAHASSEE, FLORIDA 32399-0001

August 24, 1993

Mr. William L. Piotrowski
Acting Director
Solar System Exploration Division
Office of Space Science
NASA Headquarters
Code SL
300 East Street, Southwest
Washington, DC 20546RE: Proposed Plan to Launch the Mars Environmental Survey (MESUR) Pathfinder
Spacecraft on a Mission to the Surface of Mars

SAI: FL9306250927C

Dear Mr. Piotrowski:

The Florida State Clearinghouse, pursuant to Presidential Executive Order 12372, Gubernatorial Executive Order 83-150, the Coastal Zone Management Act Reauthorization Amendments of 1990 and the National Environmental Policy Act, has coordinated a review of the above referenced project.

Pursuant to Presidential Executive Order 12372, the project is in accord with State plans, programs, procedures and objectives. Enclosed are comments received during the review process.

Based on the comments from our reviewing agencies, the proposed action is consistent with the Florida Coastal Management Program (FCMP) advanced notification stage. Subsequent environmental documents will be reviewed to determine continued consistency with the FCMP as provided for in 15 CFR 930.95. These documents should provide thorough information regarding the location and extent of wetlands dredging and filling, borrow sources, dredging or filling associated with bridge construction and stormwater management. Continued concurrence with this project will be based, in part, on adequate resolution of issues identified during earlier reviews. Any environmental assessments prepared for this project should be submitted to the Florida State Clearinghouse for interagency review.

Mr. William L. Piotrowski
Page Two

This letter reflects your compliance with Presidential Executive Order 12372.

Sincerely,



Janice L. Hatter
State Clearinghouse

JLH/bl

Enclosure(s)

cc: **Department of State**
Department of Commerce



FLORIDA DEPARTMENT OF STATE

Jim Smith
Secretary of State

DIVISION OF HISTORICAL RESOURCES

R.A. Gray Building
300 South Bronough
Tallahassee, Florida 32399-0250

July 26, 1993

Director's Office Telecopier Number (FAX)
(904) 488-1480 (904) 488-3353

Ms. Janice L. Alcott, Director
State Clearinghouse
Executive Office of the Governor-OPB
Room 411, Carlton Building
Tallahassee, Florida 32399-0001

In Reply Refer To:
Denise M. Breit
Historic Sites
Specialist
(904) 487-2333
Project File No. 932145

RE: Cultural Resource Assessment Request
SAI# FL9306250927C
Launching of the Mars Environmental Survey Pathfinder
Spacecraft from Launch Complex 17, Cape Canaveral Air Force
Station
Brevard County, Florida

Dear Ms. Alcott:

In accordance with the provisions of Florida's Coastal Zone Management Act and Chapter 267, Florida Statutes, as well as the procedures contained in 36 C.F.R., Part 800 ("Protection of Historic Properties"), we have reviewed the referenced project(s) for possible impact to historic properties listed, or eligible for listing, in the National Register of Historic Places, or otherwise of historical or architectural value.

It is the opinion of this agency that because of the project's nature it is unlikely that any historic properties will be affected. Therefore, it has been determined by this office that the proposed project will have no effect on any sites listed, or eligible for listing, in the National Register, or otherwise of historical or architectural value. The project is also consistent with the historic preservation laws of Florida's Coastal Management Program.

If you have any questions concerning our comments, please do not hesitate to contact us. Your interest in protecting Florida's historic properties is appreciated.

Sincerely,

George W. Percy
George W. Percy, Director
Division of Historical Resources

and
State Historic Preservation Officer

GWP/Bdb

Archaeological Research
(904) 487-2299

Florida Folklife Programs
(904) 397-2192

Historic Preservation
(904) 487-2333

Museum of Florida History
(904) 488-1484



STATE OF FLORIDA DEPARTMENT OF COMMERCE
Division of Economic Development

July 26, 1993

Ms. Janice L. Alcott, Director
State Clearinghouse
Office of Planning and Budgeting
Executive Office of the Governor
The Capitol
Room 441, Carlton Building
Tallahassee, Florida 32399-0001

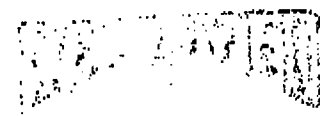

JUL 30 1993

STATE CLEARINGHOUSE

RE: SAI # FL 9306250927C

Dear Ms. Alcott:

Thank you for asking us to review and comment on the above-referenced SAI in which NASA is soliciting comments on plans to launch the Mars Environmental Survey Pathfinder spacecraft on a mission to Mars. The Department of Commerce has no comment regarding the environmental impacts associated with the launch. However, we would like to stress that space-related industry has an important positive impact on Florida's economy, both now and in the future.

Sincerely,

Wynnelle Wilson
Supervisor

WW/BEA/mm

RECEIVED
7-14-93

M 13

Date: 07/12/93
Comment Due Date: 07/26/93
SAI# FL9306250927C

STATE AGENCIES

LOCAL/OTHER

OPB POLICY UNITS

- Agriculture
- Board of Regents
- Commerce
- Community Affairs
- Education
- Environmental Reg
- Game & Fish Comm
- Health & Rehab Srv
- Highway Safety
- Labor & Employmnt
- Law Enforcement
- Marine Fish Comm
- Natural Resources
- State
- Transportation
- Trans Disad. Comm
- DER District

- RPC #1
- RPC #2
- RPC #3
- RPC #4
- RPC #5
- RPC #6
- RPC #7
- RPC #8
- RPC #9
- RPC #10
- RPC #11
- NWFWM
- SFWMD
- SWFWM
- SJRWMD
- SRWMD

- Criminal Justice
- Education
- Environment/C & ED
- General Government
- Health & Human Srv
- Revenue & Eco. Ana
- SCH
- SCH/CON

The attached document requires a Coastal Zone Management Act/Florida Coastal Management Program consistency evaluation and is categorized as one of the following:

- Federal Assistance to State or Local Government (15 CFR 930, Subpart F). Agencies are required to evaluate the consistency of the activity.
- Direct Federal Activity (15 CFR 930, Subpart C). Federal agencies are required to furnish a consistency determination for the State's concurrence or objection.
- Outer Continental Shelf Exploration, Development or Production Activities (15 CFR 930, Subpart E). Operators are required to provide a consistency certification for state concurrence/objection.
- Federal Licensing or Permitting Activity (15 CFR 930, Subpart D). Such projects will only be evaluated for consistency when there is not an analogous state license or permit.

To: State Clearinghouse
Executive Office of the Governor-OPB
Room 411, Carlton Building
Tallahassee, Florida 32399-0001
(904)488-8100 (Support 1528174)

EO. 12372

Federal Consistency

From: **DRAFT**
Division/Bureau:
Reviewer: *[Signature]*
Date:

- No Comment
- Comments Attached
- Not Applicable

- No Comment/Consistent
- Consistent/Comments Attached
- Inconsistent/Comments Attached
- Not Applicable

Florida Department of Commerce
Division of Economic Development
Bureau of Economic Analysis