

Solid State Air Purification System

NIAC Phase I Final Report

Project Number: NNX12AR14G

Submitted By:

Dr. Wayne Gellett

Principle Investigator

eSionic Corp.

1455 Adams Drive, Suite 1630

Menlo Park, CA 94025

Executive Summary

Life support systems in spacecraft are designed to provide a safe, habitable environment for the astronauts, and one of the most significant challenges is managing acceptable air quality. Carbon dioxide (CO₂) is respired normally by humans at concentrations that are toxic if inhaled directly, and as a result cabin air must be tightly managed.

The Carbon Dioxide Removal Assembly (CDRA) currently on board the ISS is the best functioning technology for manned space cabins, but has two significant drawbacks:

1. The CDRA requires that air be dried prior to CO₂ capture, and this costs energy – in fact, the system spends 4X more energy drying the air than in actually capturing and releasing carbon dioxide.
2. The CDRA works in batch mode, while downstream CO₂ processing systems require a continuous stream of CO₂. This adds unnecessary complexity, as well as a second parasitic energy loss.

An ideal system would process CO₂ continuously without any need for drying of the air, and without any moving parts. Such a system would require a fraction of the size and weight of the CDRA while dropping the cost of CO₂ capture by 5X or more. Such a technology would be enabling for future long term manned flight missions, such as a mission to Mars.

eSionic is developing a new electrochemical membrane technology using its patented innovations in electrolyte materials. In Phase I of this program eSionic has demonstrated continuous gas separation using only electricity to drive the separation, with no moving parts or pressure drops. In Phase II, eSionic will demonstrate long-term operation of the membranes consistent with the needs of NASA for this development program.

Mission Need

Life support systems in spacecraft are designed to provide a safe, habitable environment for the astronauts, and one of the most significant challenges is managing acceptable air quality. For example, CO₂ is respired normally by humans at concentrations that are toxic if inhaled directly. As a result, the cabin air must be tightly managed, with CO₂ levels kept below 0.5% at maximum, and preferably below 0.1% for the optimal safety and comfort of the crew.

NASA currently uses a complex pressure swing absorption system on the International Space Station (ISS), which operates at relatively high power (1 kW necessary for absorption bed regeneration), and is significantly larger and more massive than desired for space deployment. Further, current systems have demonstrated poor reliability in the field, with significant shutdown events on the ISS occurring in the carbon dioxide scrubbing system in 2009, and in an oxygen generation system in 2011.

The underperformance of air purification technology is considered to be a significant impediment to longer term endeavors such as a mission to Mars or space habitation. Current, proposed, and future NASA missions will extend the amount of time humans spend in sealed space environments, creating an absolute requirement for improvements in the performance of life support systems, including their weight, footprint, and energy consumption, with simplified designs that eliminate mechanical and electrical failure mechanisms.

Solution Summary

At eSionic Corp., we have developed a new membrane technology that uses ultra-thin, mechanically stable liquid films that can be utilized for gas separations. Liquid films have been investigated for decades as potential membrane materials, but they have not had any commercial success because of the difficulty stabilizing a liquid as a thin film, with no evaporation and no dewetting from its substrate. eSionic has overcome these two challenges with the invention of its “composite liquid” material, a film composed of non-volatile ionic liquid and polymer materials. These materials can be cast as pinhole-free films below 0.1 μm in thickness, and have superb mechanical properties, enabling practical implementation of liquid membranes for the first time in eSionic’s continuous electrochemical gas separation system, CEGS, developed during this program.

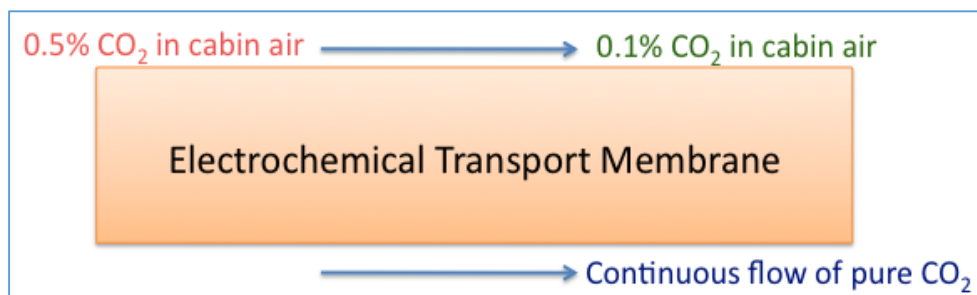

Figure 1: A simple diagram of the operation of the proposed solution. CO₂ is pumped out of cabin air using an electrochemical transport membrane. No mechanical pumps are required, the system operates in continuous rather than batch mode, and the total energy use is far below that of sorbent-based solutions.

There are many applications that would benefit from the scalable production of liquid membranes, but none so much as the concentration and removal of CO₂ from atmospheric gas mixtures. Previous studies evaluating bulk liquids as the separation system have shown that electrochemical membrane separations (conceptually described in Figure 1) offer far greater energy efficiency for CO₂ recovery than conventional sorbent systems. However, the throughput of such separations scales with the thickness of the liquid film, so the use of bulk liquids for the separation results in such low gas fluxes that the system becomes economically untenable. eSionic's composite liquid membranes dramatically improves the throughput, overcoming the most significant hurdle to the practical application of electrochemical separations.

A summary of the advantages of electrochemical membrane separations compared with both traditional membranes and sorbent-based systems is shown in Table 1 below. The technique enables a system with a far smaller footprint than existing processes, works as a continuous system, and operates at lower power. The main disadvantage is that the technology is not mature. It was the purpose of this Phase I program to build an electrochemical membrane system for air revitalization and demonstrate, through a detailed trade analysis, that it offers significant advantages to NASA compared with current and future air purification technologies based on sorption.

<u>Technology</u>	<u>Operation</u>	<u>Mechanics</u>	<u>Gas handling</u>	<u>Theoretical energy efficiency</u>
Electrochemical Membranes	Continuous	Purely solid state	Pure CO ₂ output with no pretreatment necessary	<100 kJ/mole CO ₂ captured ⁷
Traditional membranes	Continuous	Requires mechanical pumping	Mixed gas output requires further refinement	>>1000 kJ/mole CO ₂ captured ¹
Sorbents	Batch	Pumping required downstream for Sabatier process	Pretreatment necessary to remove water	>>1000 kJ/mole CO ₂ captured ²

Electrochemical Gas Separation

The principle behind and basis for this effort is the process of electrochemical gas separation. Electrochemical gas separation was originally developed in the 1970s,³ where a concentration gradient of nitric oxide was created solely through electrical pumping, with no requirement for pressure to drive it. Investigations of the applicability of this approach to carbon dioxide separations started in the 1980s using high temperature solid oxide electrolytes,⁴ and continued through the 1990s as techniques were developed to accomplish the process using room temperature materials.⁵

More recently, interest in electrochemical transport of CO₂ has been renewed using a design where a carrier species (analogous to an amine in conventional CO₂ capture tower in the energy industry) reacts with the carbon dioxide when it is in its reduced form, but releases it when oxidized. Energy is only applied

to the carrier, not to the surrounding solvent, so that no power is wasted on treating inert materials. Further, because the chemical reactions that underpin the process are specific to carbon dioxide, the process is highly selective for CO₂ over other gases, and this mechanism has been shown to offer the best theoretical energy efficiency for purification of carbon dioxide from air.

In an electrochemical membrane, no upstream compressor or downstream vacuum pump is needed, resulting in improved energy requirements and system complexity. Instead, separation is accomplished using electricity as the motive force, and applying the electricity only to the CO₂ and not to any other gas or material in the process. The process consists of four steps that occur on a continuous basis as the membrane is operated:

1. A CO₂ molecule approaches the electrochemical membrane where it reacts with a carrier such as a hydroquinone (HQ) to form a tight-binding pair.
2. This carrier-CO₂ pair diffuses to the permeate side of the membrane.
3. The carrier is oxidized to a form (Q) that has a far lower affinity for CO₂; the CO₂ is thereby released.
4. This inactivated carrier diffuses back to the feed side of the membrane where it is reduced to its active form (HQ), and will subsequently react with another CO₂ molecule.

This process is illustrated in Figure 2 below.

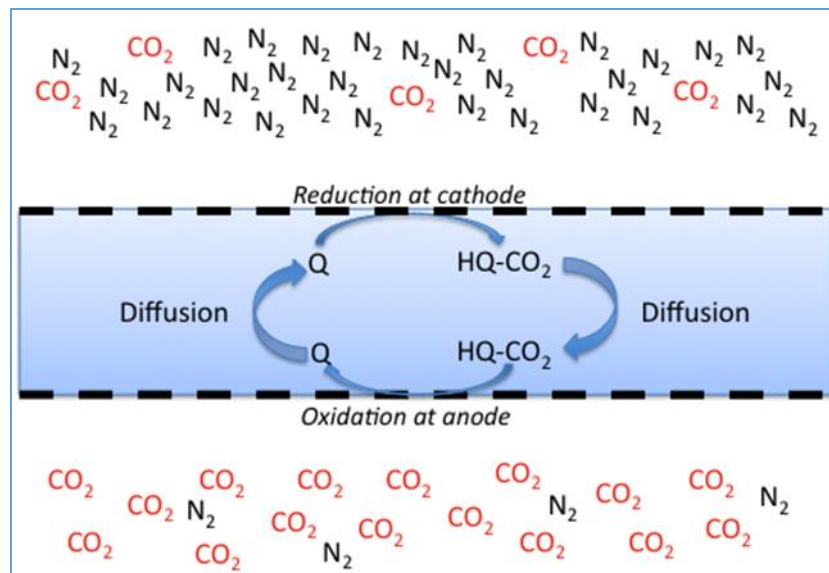

Figure 2: In an electrochemical membrane, carbon dioxide is transported from a low concentration feed side to a high concentration permeate side by reaction with an electrochemically active carrier. The electrochemistry causes the carrier to be concentrated on the feed side and depleted on the permeate side, so that transport can only occur in one direction.

Electrochemical gas separation has been shown to offer the best theoretical energy efficiency for purification of carbon dioxide from air.⁶ Just as in a conventional process, a sorbent molecule is used to capture the CO₂. However, in the case of membrane transport, this is referred to as a “shuttle”, as it absorbs the CO₂ at a first surface of the membrane and shuttles it to the second surface. Ideally, the solubility of CO₂ in the membrane material itself is low, and the only significant path to CO₂ transport across the membrane is through the use of this shuttle.

The shuttle is designed so that its affinity for CO₂ can be switched using electrochemistry, as shown in Figure 3 for a 2,6-di-tert-butyl 1,4-benzoquinone (DtBBQ). In this example, the reduced form of DtBBQ has a strong affinity for CO₂, but this affinity is destroyed when the molecule is oxidized, enabling electrochemical control of CO₂ release. In this process, energy is directed solely at the sorbent molecule, and there is no need to heat the system or otherwise direct energy to anything other than sorbent regeneration.

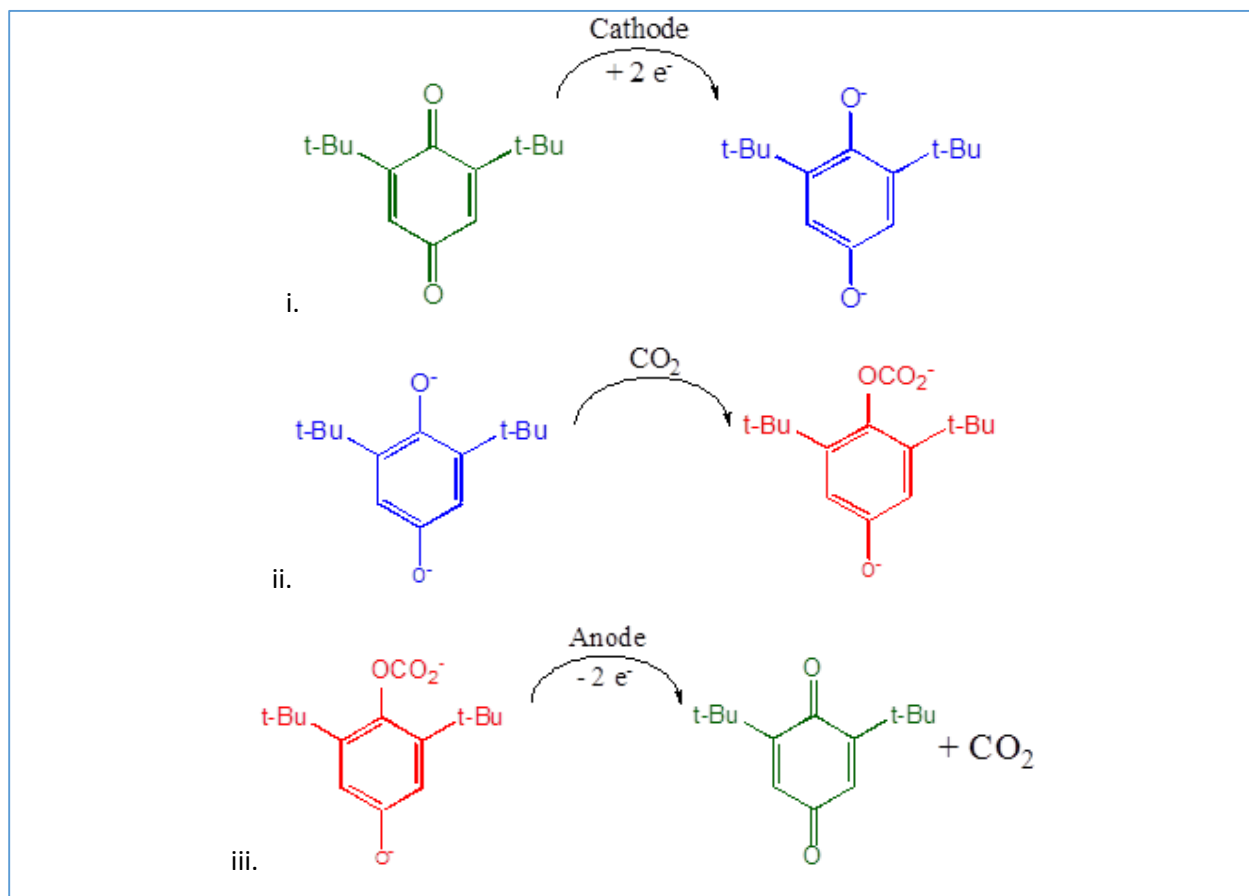

Figure 3: The neutral DtBBQ shuttle in (i) is reduced at the cathode to the active CO₂-binding species, which then reacts with CO₂ to form a chemical bond in (ii). The active complex then diffuses across the membrane from the cathode to the anode, where it is re-oxidized to form the original DtBBQ, releasing CO₂ at the electrode. The pumping of CO₂ is driven by this chemical potential: CO₂ is bound at a first side of the membrane by the high concentration of CO₂-binding species at the cathode, and released on the other side of the membrane because there is a low concentration at the anode. Effectively, this system makes a “CO₂ diode”, where the conductance of CO₂ is much higher in one direction than the other.

The effectiveness of an electrochemical shuttle has been demonstrated experimentally by Scovazzo et al⁷ in 2003, where carbon dioxide was pumped from a source gas with 5000ppm CO₂ to a pressure of 1 atm of pure CO₂, using solely electrochemistry. The quinone redox reaction is a two-electron process, so that theoretically 0.5 mole of CO₂ will be pumped for every electron mole; in practice, the researchers achieved an efficiency of 0.42 mole/electron, with losses stemming from slow permeation of the concentrated CO₂

back through the membrane into the source gas. Even with such modest leakage, this overall performance makes electrochemical pumping by far the most energy efficient process used to purify CO₂ from low concentration gas streams.

Electrochemical membrane processes, while of academic interest, have not been scaled for practical use for two reasons. First, the flux of gas through a continuous electrochemical system scales inversely with the thickness of the active layer. Electrochemical carriers are only effective in a liquid when they can diffuse across the membrane, and it has previously not been possible to constrain a liquid to a film less than a few hundreds of microns, even in academic research. This contrasts with the active layer of conventional membranes, which are three orders of magnitude thinner. There has not been, prior to the work in this program, a practical pathway to achieve the low film thicknesses required for useful fluxes.

Second, the most commonly studied carrier, 2,6-di-*tert*-butylbenzoquinone, becomes deactivated in the presence of oxygen. The mechanism for this is well-understood: the reduction potential of this benzoquinone is more negative (higher magnitude) than that of oxygen, so when the system is exposed to air, oxygen is constantly reduced to superoxide at the reducing electrode, and this superoxide reacts with and destroys the benzoquinone. This flaw has not prevented academic demonstration of the technology, but any practical system must use a carrier with a significantly more positive (lower magnitude) reduction potential. The practical limitations on carrier reduction potential have been overcome recently by researchers examining benzoquinone electrochemistry in other fields, and by integrating this technical knowledge into an electrochemical membrane system. We will be able to demonstrate a long-term air-stable electrochemical separator in future phases of this program.

Phase I Results

The goal of this Phase I NASA-funded project was to establish the proof of concept of electrochemical gas separation using eSionic's liquid membrane and to provide significant advances to establish the potential for liquid membranes to revolutionize space-deployed life support systems, including:

- Experimental validation that electrochemical transport using a composite liquid membrane will extract carbon dioxide from simulated cabin air to below 0.5%, and measurement of the throughput of this system
- Detailed trade analysis based on the experimentally determined CO₂ fluxes, culminating in an estimation of the required size and weight of a system used to clean the air of the ISS (as a benchmark), as well as a comparison of the size and energy use of this technology to currently available CO₂ scrubbing systems.

Phase I goals for this program were successfully accomplished through a program of system modeling, membrane synthesis and fabrication development, and optimization of carrier concentration and mass transport properties in a composite membrane film.

System Modeling

To gain a better understanding of the requirements needed for the electrochemical membrane system for this application with low initial concentrations of CO₂ (0.5%), an initial system model was developed during this phase of the program. A theoretical analysis of the energy consumption inherent in batch electrochemical systems has been published before by Scavazzo,⁷ but this does not directly relate to performance for continuous separations. Work by Ward^{8,9} and others^{10,11} on continuous systems have

developed mathematical analyses of the chemical and energy performance from such systems. The work below derives in part from these previous analyses, and is discussed in depth here because of the criticality of the cost advantage of CEGS in providing the motivation for this proposal.

In an electrochemical separation process, the affinity of the carrier (e.g., a quinone) to carbon dioxide changes by orders of magnitude when changes are made to the carrier oxidation state. Pumping the gas to create a concentration gradient comes at the cost of increasing the free energy of the system from the initial pressure p_i to the final pressure p_f , and from this free energy perspective, an electrochemical system yields results that are no different from a generic (method-independent) thermodynamic analysis of the work of concentration, because all of the electrochemical work is directed towards the carbon dioxide and not other, inert molecules. As a result, the work of concentration comes at an inherent thermodynamic penalty of only 9.68 kJ/mol for 90% CO₂ capture. A graphical representation of the minimum energy for the separation is shown in Figure 4.

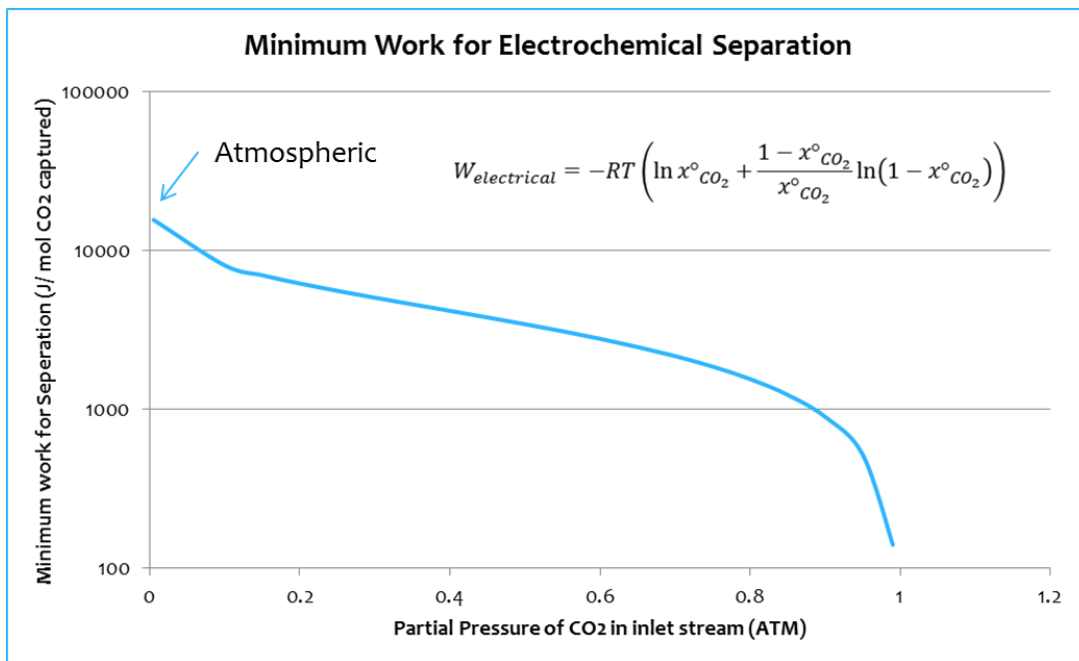

Figure 4: Minimum energy required for gas separation

To better understand what drives the transport, it is helpful to consider the concentration profiles of the carriers, as shown in Figure 5, carrier will be enriched, and the inactive carrier will be ideally completely depleted. The CO₂ will thus react with the active carrier on the feed side, and when the CO₂-carrier complex diffuses to the permeate side, the carrier will be re-oxidized and release its CO₂ payload. By contrast, on the permeate side, there is no active carrier for the CO₂ to react with, and thus there is no mechanism that allows it to back-permeate to the feed side. The concentration gradient in CO₂ is thus a direct result of the concentration gradient of active carriers.

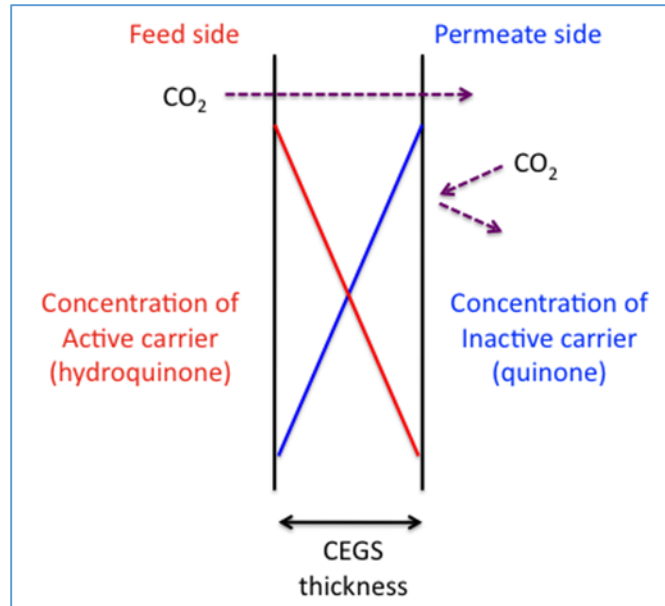

Figure 5: Carbon dioxide is transported across the CEGS material in a single direction because of the gradient in carriers created by electrochemistry

A loss mechanism that is relevant to CEGS and Phase I development of this program is leakage. In an electrochemical system, gas molecules that cross the membrane and do not react properly, detract from the total systems efficiency. In CEGS, leakage corresponds to undesired permeation of molecules, either loss of CO₂ from the permeate side back to the feed side, or transfer of N₂ from feed to permeate. Transfer of N₂ will result in a degraded selectivity, and if significant, can result in degraded purity of the CO₂ permeate to the downstream O₂ recovery process from CO₂. Loss of CO₂ back through the CEGS layer will also degrade selectivity, and will further incur an energy penalty as every lost CO₂ molecule will have to be transported an additional time to recapture it. These loss processes are illustrated in Figure 6. From a systems perspective, it is a goal of this program to develop a CEGS material where CO₂ electrochemical transport Q_{EC} is much greater than either carbon dioxide or nitrogen fluxes Q_{CO_2} or Q_{N_2} via traditional membrane (solution diffusion) processes.

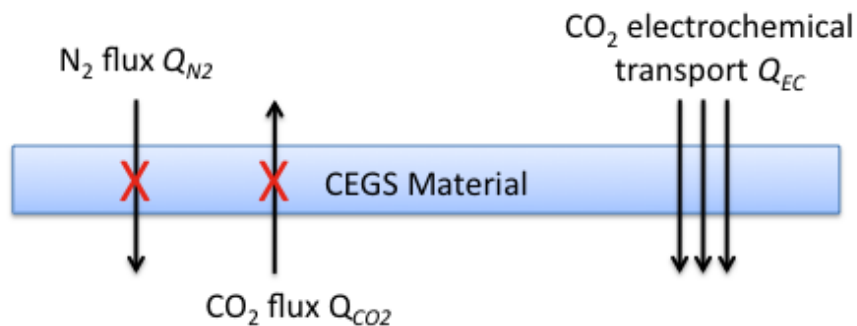

Figure 6: The total flux of gas through the membrane includes CEGS transport as well as conventional membrane solution-diffusion processes. In an ideal system, solution-diffusion transport will be limited to a very small fraction of CEGS flux.

A representation of the total electrochemically-related gas flux through the system is

$$Q_{EC} = S_{EC} D_{EC} E_{EC} \quad (1)$$

S_{EC} is the concentration of the carrier in the CEGS material; D_{EC} is the diffusivity of the carrier-CO₂ complex in the matrix; and E_{EC} is the potential gradient that creates a current that pushes CO₂ forward. Note that D_{EC} is actually composed of multiple terms, representing the diffusion rate of the oxidized carriers and the reduced carriers with and without carbon dioxide complexation;¹² however, because the diffusion rates are dictated by the viscosity of the fluid, these rates will be generally similar, and such differences is ignored in the treatment here.

The total flux of CO₂ through the system, including losses, can thus be expressed as the difference between CO₂ forward permeation by CEGS transport, and back-permeation through a traditional solution diffusion mechanism:

$$Q_{Tot} = S_{EC} D_{EC} E_{EC} - S_{CO_2} D_{CO_2} P_{CO_2} \quad (2)$$

Where Q_{Tot} is the total CO₂ flux in the downstream direction taking into account both mechanisms of transport; S_{CO_2} is the solubility of CO₂ in the CEGS material; D_{CO_2} is the diffusivity of carbon dioxide in the CEGS material; and P_{CO_2} is any partial pressure increase caused by the electrical pumping, which drives CO₂ back in the reverse direction via the solution diffusion mechanism.

The CO₂/N₂ selectivity of the system is the ratio between Q_{Tot} and Q_{N_2} , the flux of nitrogen gas through the CEGS system from a conventional solution diffusion process.

$$Q_{N_2} = S_{N_2} D_{N_2} P_{N_2} \quad (3)$$

$$Selectivity = Q_{Tot} / Q_{N_2} \quad (4)$$

The drivers of these performance metrics are thus listed below, along with the preferred direction to maximize performance.

- Carrier solubility ↑
- Carrier diffusivity ↑
- CO₂ solubility ↓
- CO₂ diffusivity ↓
- N₂ solubility ↓
- N₂ diffusivity ↓
- Partial pressure change in CO₂ across the membrane ↓

Finally, to minimize polarization losses it is critical to maintain as high of a flux of fresh carrier to the electrode at all times. The primary metric to correlate the degree of polarization to be expected is the Damköhler number D_{α} , which is the ratio of reaction time to diffusion time:

$$D_{\alpha} = k_c C_0^{n-1} \tau \quad (5)$$

Where k_c is a rate constant, C_0 is the initial concentration, n is the reaction order, and τ is the mean residence time of the species in the reaction zone, which in turn is usually expressed as the ratio of the capacity of the system and its flow. Ultimately, in systems with a good oxidation reduction kinetics and slow diffusion (high Damköhler number), there will at any moment be a build-up (polarization) of the undesired carrier at each electrode, which in turn (via the Nernst equation) requires that additional electrical potential be applied to keep the reaction moving in the forward direction.

Because the Damköhler number depends on the transport time of the species, a high diffusivity (low viscosity) is preferred for the CEGS, so that this matches the need to have high diffusivity in order to achieve a high Q_{EC} . τ is directly related to the thickness of the film, and so the thinner the CEGS films, the lower the polarization losses will be, and the better the overall efficiency.

The overall goal of this Phase I effort was to develop a gas separation membrane that utilizes the unique properties of eSionic's composite liquid membrane with redox active carrier molecules for carbon dioxide transportation for a proof of concept demonstration of this new technology. The membrane material was designed with the factors of conductivity, solubility, viscosity, and diffusion properties discussed here in the initial system model for technology feasibility demonstration in this program. Descriptions of the membrane system, electrochemistry, and gas separation results are discussed in further detail in the following sections.

Membrane

The core of this project arises from eSionic's "composite liquid" material, a mixture of non-volatile liquids and a polymeric materials. This mixture of materials is cast as a thin film, where the non-volatile liquid is held in place by the high capillary pressure within the membrane. These films retain all of the properties of the pure liquid, including its mobility throughout the film and its ability to interact with gases, yet allows it to withstand large mechanical pressures without deformation or blow-out. The preferred non-volatile liquids are ionic liquids, which serve as the electrolyte in the CEGS system, and which have been extensively studied already for applications in carbon capture.^{13,14} All of the components used to fabricate these films are available commercially, compatible with the scaling of this technology for CO₂ separation and air purification in spacecraft applications.

During the course of this Phase I project, significant effort was given to develop a method for casting free-standing, solid electrolyte membranes with 50% ionic liquid content and high concentration of redox active carrier molecules for separation of carbon dioxide in low concentration gas mixtures. The membranes are cast as a film and form solid electrolyte membranes necessary for electrochemical gas separation. One issue that came up during this project was the incorporation of the redox carrier species (2,6-di-tert-butyl 1,4-benzoquinone) into the membrane. The membranes were first soaked in solutions of the redox carrier in solvents and allowed to uptake the redox species. Several solvents were evaluated, including ionic liquid that is present in the membrane, with very little change in appearance of the

membrane, indicating little or no carrier molecule uptake. The redox species in solution is yellow and the membranes remained colorless after several days in solution. Focus then shifted to mixing the redox species into the solid electrolyte casting mixture and then forming the membrane. This method proved to be successful, but also required significant optimization to achieve the highest concentration of carrier in a membrane that is less than 100 microns thick and maintain the necessary mechanical stability for gas separation. The result of this portion of the program was the successful preparation of membranes that are ~100 microns thick and contained sufficient amounts of carrier molecules, an example of one is shown in Figure 7.

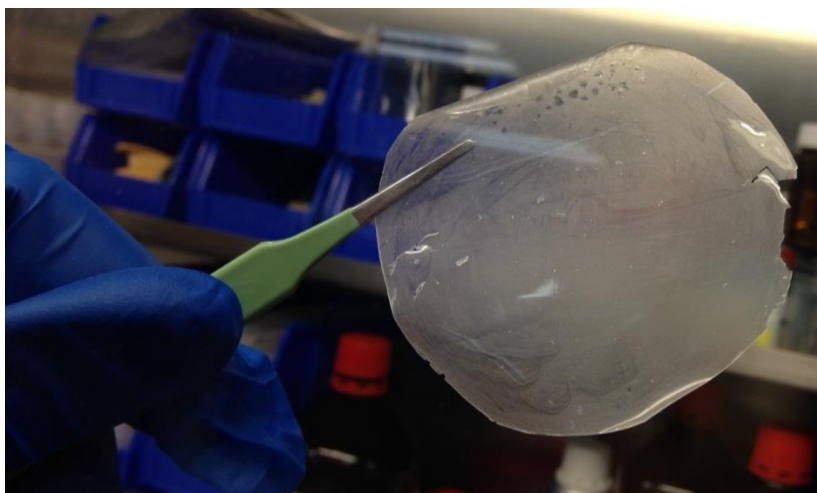

Figure 7: Solid electrolyte membrane with 50% ionic liquid content that was formed for use in CO₂ separation.

These results show that eSionic has created a stable supported liquid membrane with the mechanical integrity necessary for the incorporation and retention of redox active carrier molecules, casting in thin films, and integration into robust systems. This has allowed for the successful testing of these membranes using electrochemical transport, leveraging the existing literature and Phase I efforts in this program to demonstrate the capability to pump carbon dioxide with high selectivity from air, using only electrical input.

Electrochemistry in the Membrane

The electrochemical membrane is composed of our composite liquid material, an ionic liquid, which serves as the system electrolyte; polymer binder; and di-*t*-butylbenzoquinone carrier. The film is produced by solvent casting from a precursor solution, described in the previous section, into a free-standing film approximately 100 μm thick. A sample of this film is shown in Figure 8, where carbon fiber electrodes are placed into the top of the film so that the bulk is visible to the camera. This film was supported between two glass slides and as part of the overall development protocol, electrochemical evaluation of the redox behavior of the composite liquid film was examined.

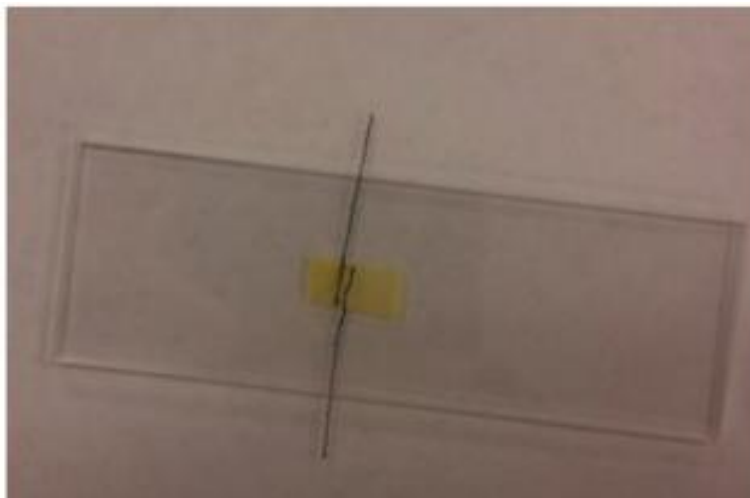

Figure 8: A composite liquid film (yellow) containing di-*t*-butylbenzoquinone carrier species with two electrodes embedded in its volume.

Using this experimental setup, it is possible to record a cyclic voltammogram of the benzoquinone carrier in the thin film membrane, further confirmation of the electrochemical nature of the purification process and activity of the carrier molecule in a solid electrolyte matrix. As can be seen from the cyclic voltammogram of the film in Figure 9, the carrier reduction requires application of an electrical potential of $<-1.2\text{V}$. It should be noted that the quinone voltammetry shown below was collected in air rather than in pure nitrogen and so is not reversible because of the formation of superoxide in the ionic liquid solvent when oxygen is present;¹⁵ improvements to the system with more stable carriers will be studied in Phase II of this program. This result is significant, because it represents the first time that electrochemistry measurements on redox active species within this solid electrolyte membrane system is possible. This provides the feasibility of this concept working for CO_2 separation using these composite liquid membranes.

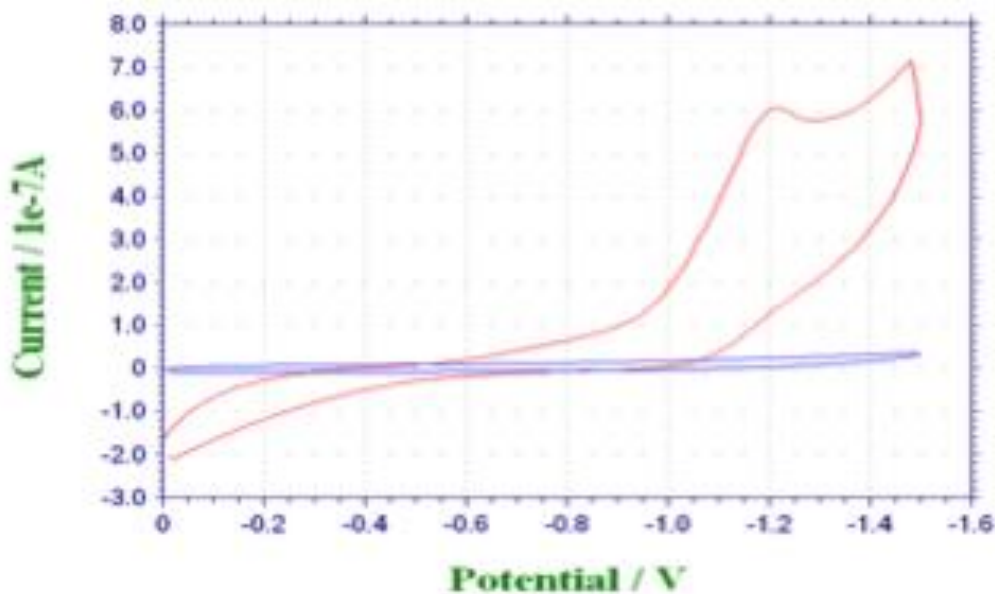

Figure 9: A sample of solid CEGS film loaded with quinone carrier, and the CV of that carrier.

In literature and as noted in previous sections of this report, the carrier 2,6-di-*t*-butylbenzoquinone has been used for CO₂ separation, but this molecule is known to become deactivated in the presence of oxygen, and sufficiently volatile that its long term survival in a membrane configuration with oxygen present is questionable. The mechanisms for the deactivation of reduced quinones have been extensively studied in academics due to the importance of quinones in biology, with the finding that electron-rich semiquinone radicals transfer an electron to oxygen to form a superoxide ion, which in turn will rapidly destroy most organics, including the quinone itself. Other researchers have previously fabricated electrochemically modulated CO₂ carriers that are stable to both oxygen and water using more exotic binuclear copper compounds, so different carriers that are stable in oxygen are available and will be examined in depth during Phase II of this project. Choice of a more stable quinone carrier requires the use of a quinone with a reduction potential more positive than that of molecular oxygen, so the superoxide failure mechanism is avoided.

Practically, this means that full reduction of the quinone to the hydroquinone must occur at a potential significantly more positive than -0.9V vs SCE, where superoxide has been shown to form in ionic liquids. Based on our experience with polarization losses in fuel cells, a potential of > -0.3V vs SCE is preferred. By contrast, the first reduction potential of 2,6-di-*t*-butylbenzoquinone, reducing from the quinone to the semiquinone is near -0.7V vs SCE, and the reduction of the semiquinone to the hydroquinone is nearly 0.5V further negative, Figure 10. Thus, it is not surprising that the cyclic voltammetry of 2,6-di-*t*-butylbenzoquinone in the electrolyte film has performed the way it does as a carrier in the presence of oxygen.

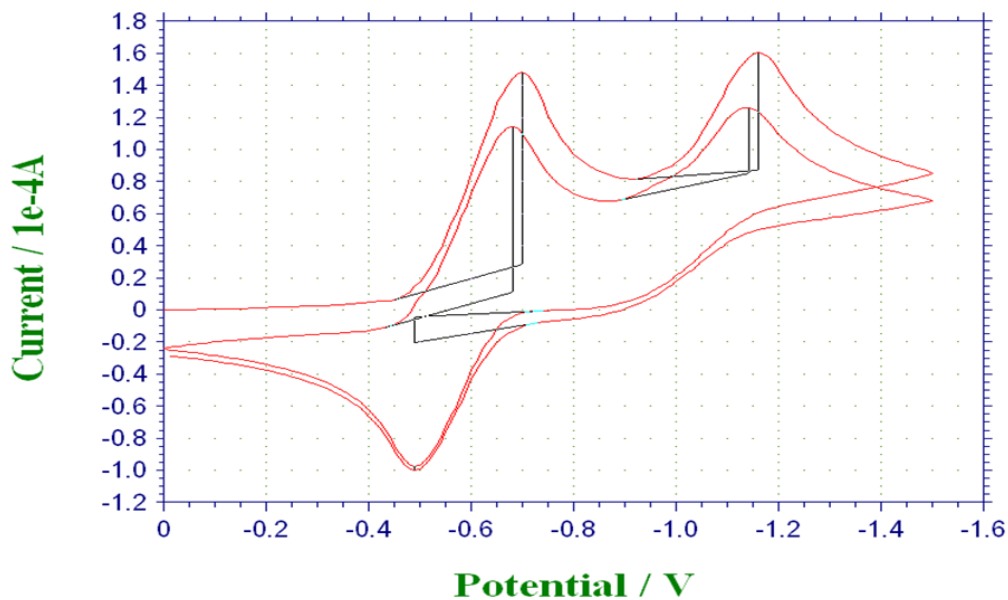

Figure 10: Cyclic voltammogram of the di-*t*-butylbenzoquinone carrier species in ionic liquid/propylene carbonate solution. A glass carbon disk electrode was used as the working electrode. This experiment is required to examine the stability of the carrier and to determine the potential required for the two electrode test cell.

Achieving the required potential requires two changes, both of which have been previously discussed in the quinone electrochemistry literature:

- Substitution of the ring by electron-withdrawing groups will shift the reduction potential in the positive direction. For example, the carrier 2,6-dichlorobenzoquinone is reduced at a potential roughly 0.5V more positive than 2,6-di-*t*-butylbenzoquinone
- The presence of strong hydrogen bonding or acid groups in the solvent can serve to collapse the two separate reductions at two separate potentials into a single two-electron reduction. The semiquinone reduction potential is further increased (made more positive) than it is in non-binding solvents as well.

Our target of -0.3V vs SCE for a carrier can be achieved by selection of an electrophilic quinone such as commercially available dichlorobenzoquinone or bis(trifluoromethyl)benzoquinone, and ensuring through the use of the appropriate solvent and/or additive that the reduction takes place in a single two-electron step.

CO₂ Separation

The evaluation of the redox active membrane system was performed using a single cell testing fixture for the electrochemical evaluation of gas systems in a test stand designed and built in-house for this program. The composite liquid membrane was fixed in place in between gas distribution electrodes, as shown in the schematic in Figure 11, forming the CEGS component of the system shown schematically in Figure 12. Using the single cell fixture for the evaluation of the membranes allows for the separation operation to be evaluated at multiple conditions. These conditions include variable gas flow rate for both the mixed gas stream and sweep gas, temperatures ranging from room temperature to 100°C, and gas diffusion rates through the use of several different types and thickness of gas dispersion electrodes.

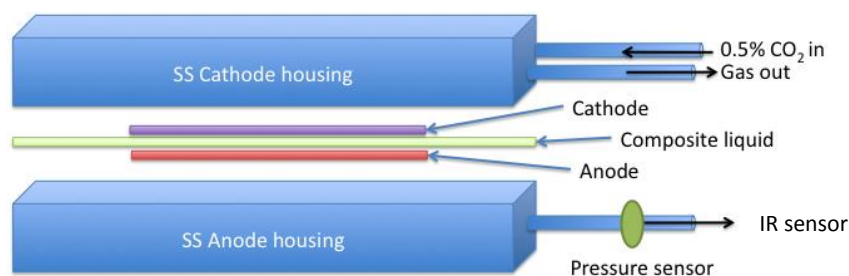

Figure 11: The configuration of the membrane system. The cathode and anode housings are made of stainless steel, and make electrical contact to the higher surface area electrodes.

In this experimental setup, pre-mixed gas sources is passed via a mass flow controller (MFC) over the CEGS module. The gases flow to the CEGS unit and are either permeated through the material or rejected. Permeated gases are swept by Ar gas towards a gas analyzer to accurately determine the CO₂ concentration in the gas stream, which in our current system is an in-line IR gas analyzer. Either the permeate or retentate may be directed towards the gas analyzer by valve control. This setup is illustrated schematically in Figure 12. The concentration of CO₂ in the gas stream is monitored in real time throughout the separation evaluation.

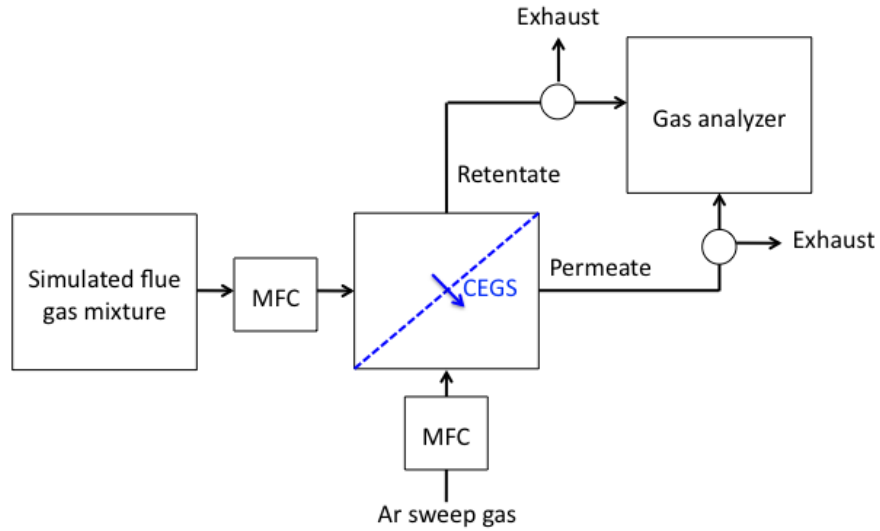

Figure 12: A flow schematic of eSionic's lab-scale CEGS test setup

The membranes are evaluated in the electrochemical test fixture that has an active area of 5 cm² and is capable of evaluating a large range of membrane thickness developed during this program. Images of the experimental setup are shown in Figure 13 and Figure 14. A pre-mixed nitrogen gas mixture with 0.5% CO₂ in nitrogen is introduced into the bottom half of the test fixture (cathode) at controlled flow rate. A carbon cloth electrode is used as the gas diffusion flow field for both the cathode and anode and is secured with gaskets. The solid electrolyte is fixed between the two flow fields and a gas tight barrier is formed. The CO₂ rich gas that is formed on the anode side is swept with an argon carrier gas and sent to an in-line IR sensor for analysis of the CO₂ concentration. A potentiostat is connected to the test fixture and is used to polarize the electrodes.

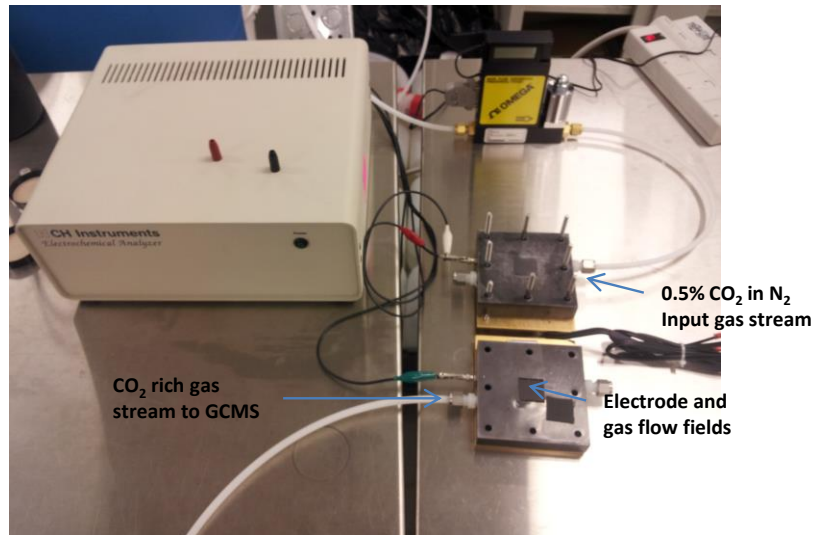

Figure 13: Experimental setup for evaluation of the efficiency of eSionic composite electrolyte for CO₂ separation.

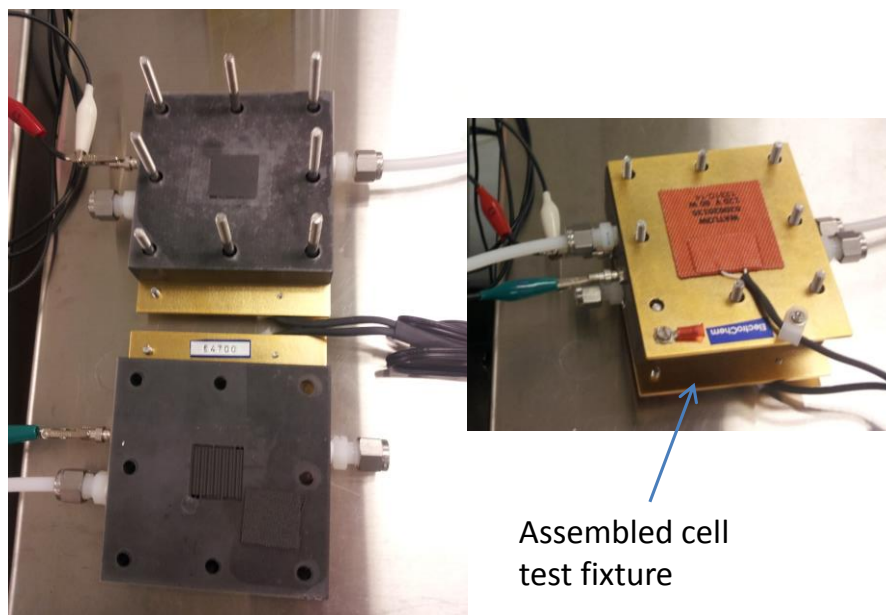

Figure 14: Electrochemical test fixture for electrochemical membrane evaluation. The fixture on the right demonstrates the assembled unit with electrodes and the membrane materials.

CO₂ capture using the previously described membranes loaded with 2,6-di-*t*-butylbenzoquinone was used to demonstrate initial CO₂ capture in a batch mode using the single cell test fixture. 0.5% CO₂ in N₂ was introduced into the cathode of the single cell as the feed stream and the cell was allowed to rest for 4 minutes to make sure that the membrane was pinhole free. After 4 minutes, the electrodes were polarized and the concentration of CO₂ in the feed stream was reduced from 0.5% to 0.1% in 20 seconds. This represents a CO₂ capture of 90% using the developed electrochemical membrane from this program. After an additional 30 seconds, all of the reduced quinone species at the cathode had captured a molecule of CO₂. At this point, the membrane had become saturated and the polarization was switched to oxidize the CO₂-quinone species. This reduced the affinity of the quinone for CO₂ and released the CO₂ back into the feed stream, increasing the concentration up to 0.7% in 20 seconds. Once all of the bound CO₂ had been released, the concentration of the gas in the feed stream returned to the baseline value of 0.5% after 4 minutes, the data of this system is shown in Figure 15. This represents a significant result for the proof of concept for this program. This demonstrates the feasibility of using the concepts developed during this program to electrochemically reduce the concentration of CO₂ from 0.5% to 0.1% in a simulated cabin air stream. This result also highlights the importance of optimizing the viscosities and transport properties of the membrane for continuous operation. In the system highlighted in Figure 15, a high carrier loading in the film was used. The high loading levels of the carrier imparts a high viscosity to the composite liquid -- as a result the transport step is slower than the absorption step and the membrane saturates. This limited the operation of this system to a batch mode. Controlling the nature of the materials and carrier concentrations, both lower viscosities and thinner films can be accessed to unlock this potential performance in a continuous mode of operation that is required to achieve the projected energy savings of this system.

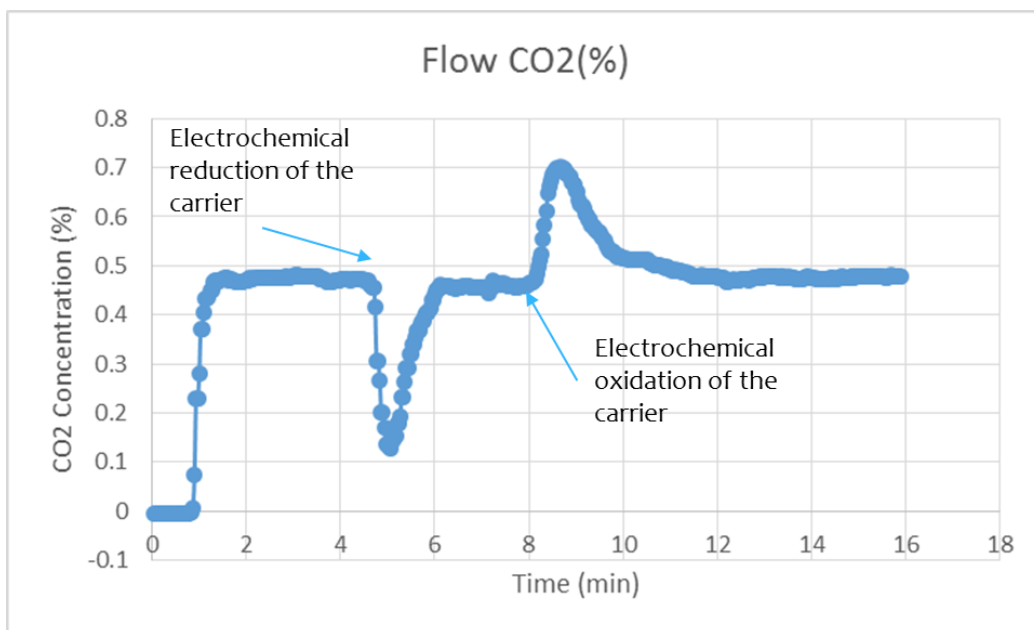

Figure 15: Batch operation of the electrochemical gas separation membrane system developed in this program. The CO₂ is quickly removed from the gas stream when the carrier species is reduced and then can be reversibly released by oxidized the carrier molecule with the bound CO₂.

Initial improvements in the transport properties of the electrochemical membrane was started during Phase I of this program. The goal was to demonstrate the continuous operation of this system to reduce the concentration of CO₂ to levels below 0.5%. In order to improve the transport properties of the system, the concentration of the carrier species in the membrane was decreased. This resulted in the reduction of viscosity of the system as CO₂ was absorbed by the reduced form of the carrier species, allowing the continuous separation of CO₂ from the feed stream. Figure 16 demonstrates the success of electrochemical pumping. The presence of the membrane has no impact on the CO₂ concentration until the electrodes are switched on, approximately at minute 25. From this point, the concentration of CO₂ in the air drops steadily before reaching a steady state concentration of 0.3% fifteen minutes later. Further decrease in concentration is possible by using larger electrode area and lowering the gas flow rate into the system. At 52 minutes, the electrodes are switched off, and the system recovers to the initial concentration over the subsequent ten minutes.

The goal of this Phase I program has been to demonstrate the feasibility of purification of carbon dioxide using a thin film electrochemical membrane. We have exceeded this goal, constructing a single cell system capable of continuously purifying simulated cabin air from 0.5% CO₂ down to 0.3% CO₂, using only electricity as a driving force. Purification to 0.3% represents an interim result of this program and as proof of concept of the process, with further improvements possible. By rationally controlling the materials properties defined in the modeling portion of the Phase I, both higher purification levels and greater fluxes are achievable, and these activities are planned for Phase II of this program.

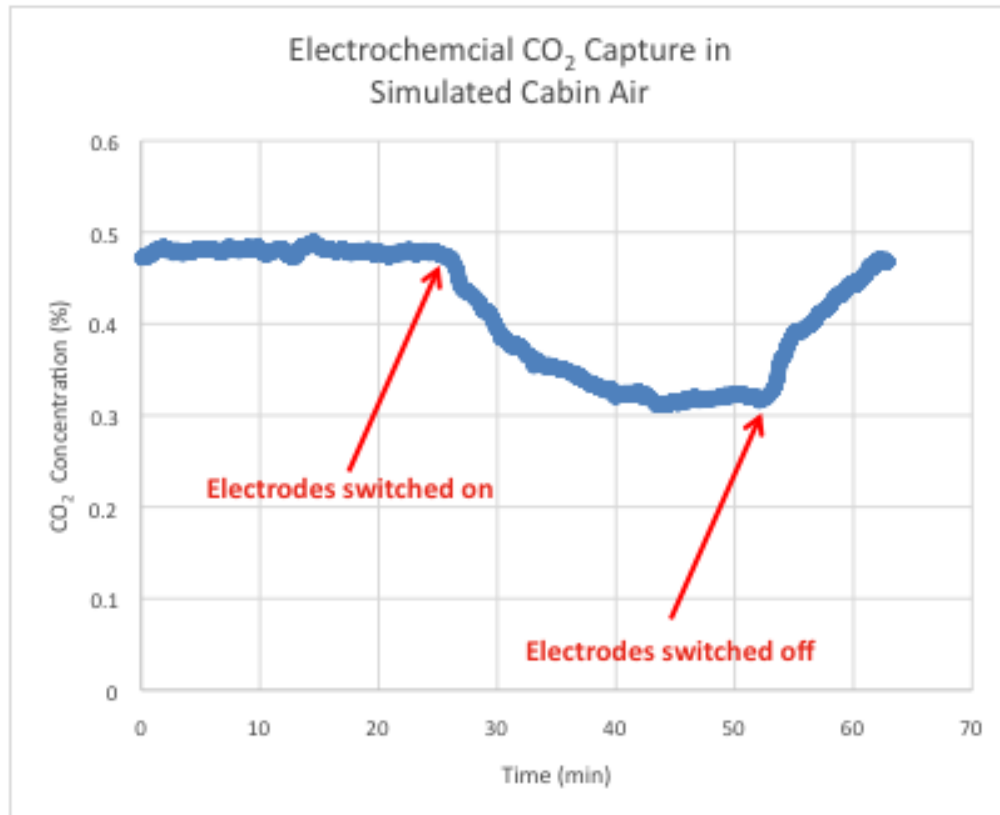

Figure 16: The concentration of CO₂ in the permeate stream drops from 0.5% in the absence of an applied field, achieving a steady state concentration of 0.3% after 15 minutes. When the electrodes are switched off, the system returns to the feed concentration.

Comparison and System Advantages to Current System

Life support systems in spacecraft are designed to provide a safe, habitable environment for the astronauts, and one of the most significant challenges is managing acceptable air quality. Carbon dioxide (CO₂) is respired normally by humans at concentrations that are toxic if inhaled directly, and as a result cabin air must be tightly managed.

There is a significant trade-off, however, between the desire to keep carbon dioxide levels below the threshold where the air turns toxic, and the opposing desire to minimize the size and energy consumption of air revitalization equipment. On the International Space Station (ISS), a single carbon dioxide removal assembly (CDRA) is capable of maintaining cabin air at <5.3 torr CO₂ for up to 9 crew members,¹⁶ although studies have shown that optimally CO₂ concentrations should be kept below 4 torr.¹⁷ Consistent maintenance of CO₂ at this lower level, or operation at times of heavy CO₂ load such as at shuttle docking, require the operation of a second CDRA unit.

Under normal operating conditions, the CDRA consumes about 2.1 kWh per kg of CO₂ removed;¹⁸ for a typical six-member crew, this imposes a cost of approximately 12-15 kWh per day of operation. This is a substantial load, high enough that continuous operation of more than one CDRA unit is simply not practical.¹⁷ Realistically, the energy consumption required for CO₂ purification today is so high that missions must operate at the limits of human CO₂ tolerance, and spacecraft power systems are designed around the constraints imposed by the revitalization units.

Surprisingly, 80% of the power consumption of the CDRA arises not from the CO₂ separation process itself, but from a pre-treatment step where the air is dried to ensure the CO₂ sorption beds are effective. The step of drying the air is not rigorously necessary, as downstream units such as the Sabatier process are water tolerant, and in fact create water as a reaction product and collect it in their own subsystems. However, there is no CO₂ sorbent technology today that can separate CO₂ without this drying step, and still meets NASA criteria for reliability and cabin compatibility.

An efficient, water tolerant and mission-compatible replacement to the existing CDRA system could reduce its energy consumption five-fold, enabling improvements in cabin air quality and freeing significant (10 kWh per day) energy for other mission needs.

The CDRA in the International Space Station is constructed with two parallel purification channels, each with a desiccant unit comprised of 13X zeolite and silica gel and an absorber comprised of 5A zeolite, as shown schematically in Figure 2. The cabin air flows over the desiccant in a first channel to remove moisture, and then flows over the 5A zeolite where the CO₂ is captured. Once the sorption chambers are near saturation, the channel switches to regeneration mode, and the system is heated to release the water and the carbon dioxide, which are recaptured as separate streams. While the first channel is in regeneration mode, the flow of cabin air is directed to the second channel, so that purification can be carried on continuously despite the batch nature of the capture process.

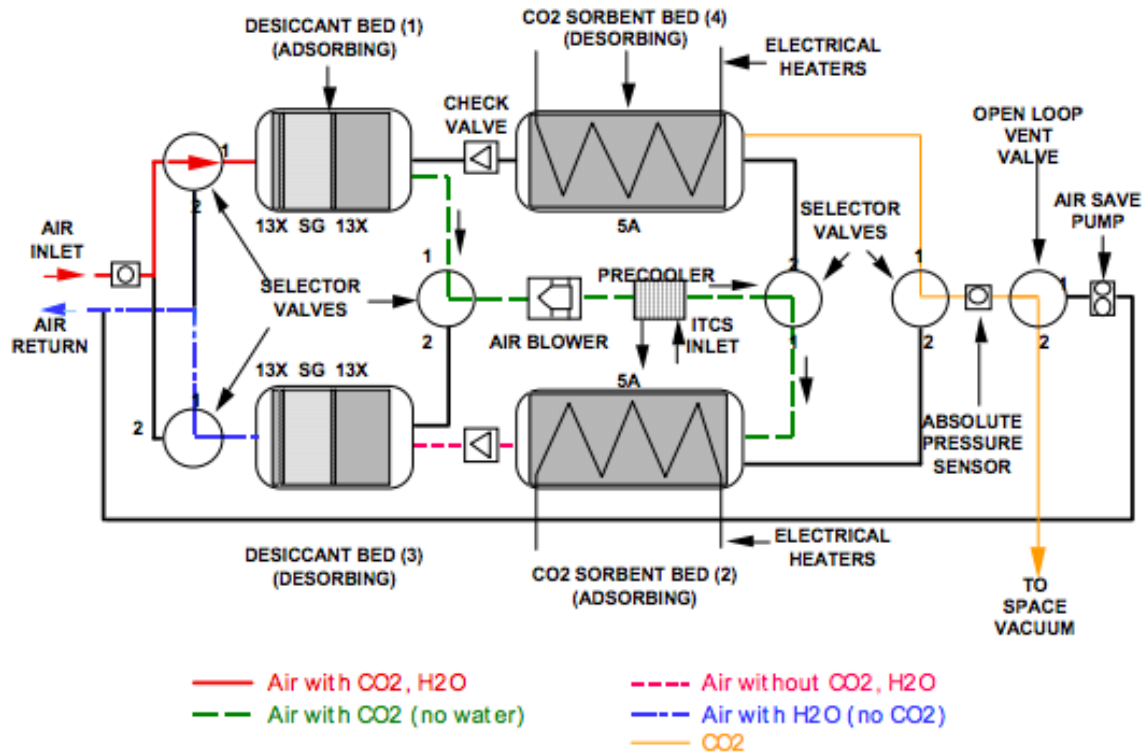
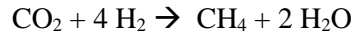

Figure 2. A schematic of the ISS CDRA.¹⁹ In this approach, the collected CO₂ is vented directly into space to remove it from the cabin.

In this original carbon capture design, the zeolite concentrated the CO₂ from <1% to >99% purity in a single stage, and the practice of venting the CO₂ into the vacuum of space minimized the total energy requirements for air revitalization, yet did not sacrifice any of the other cabin gases because the CO₂

quality was so high. However, the long term nature of the ISS mission, as well as future NASA missions, made it desirable to keep this gas on the vessel rather than exhaust a steady stream off board.

In 2010 the ISS installed a Sabatier reactor, which strips the oxygen from the CO₂ for reuse in the station.²⁰ The Sabatier reaction proceeds according to the path below, where CO₂ reacts with hydrogen to produce methane gas:



The Sabatier reaction is a continuous process where CO₂ from the CDRA is fed into the reactor, reacting with H₂ created by water electrolysis. Rather than vent gas into space as performed in previous implementations of the CDRA, the purified CO₂ is instead passed into this reactor to recapture the oxygen atoms from CO₂ and recirculate them into the cabin as water. Because the CDRA creates CO₂ in a batch process, the CO₂ must be pressurized and held in a CO₂ accumulator so that it can be slowly and continuously fed into the Sabatier reactor. Water produced during the reaction is collected on a cold plate and separated from the methane, which is vented into space or collected as a fuel for subsequent use. The Sabatier reaction operates at high temperature, which is maintained in part using heat extracted from this exothermic reaction.

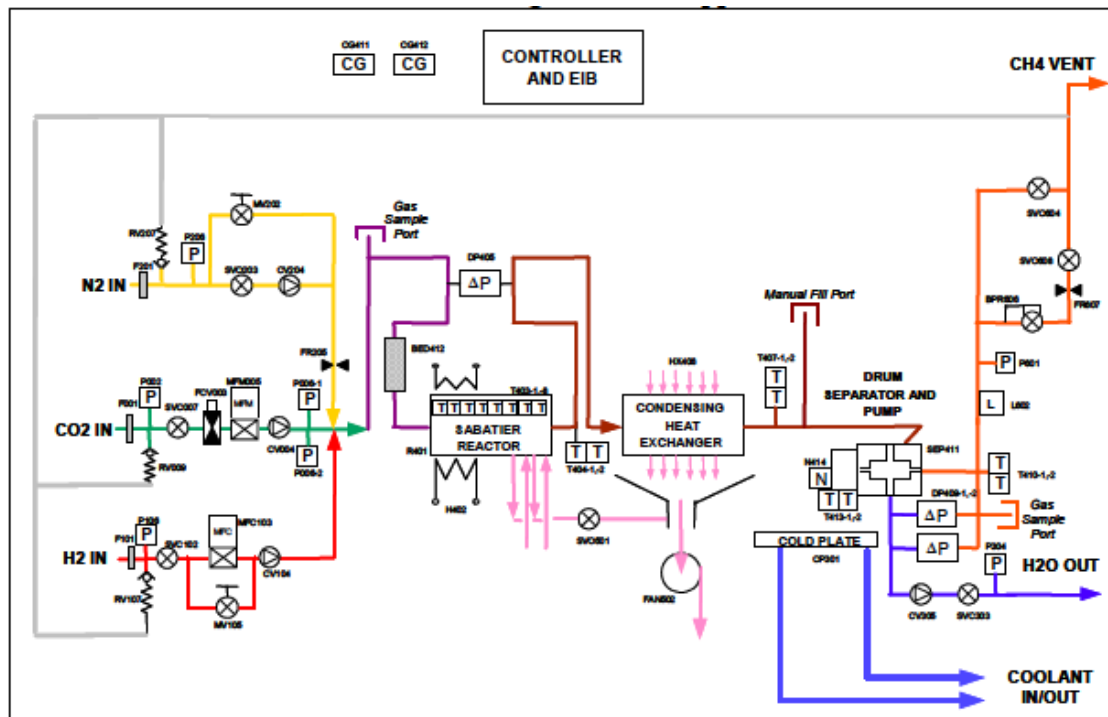

Figure 3. A schematic of the Sabatier feed process, which begins after the CO₂ is purified by the CDRA and pressurized and stored by the accumulator.

The Sabatier process has been optimized for the existing CDRA, yet in many ways is a poor match for it, as its process input requirements do not directly align with the output gas:

- The Sabatier process requires a continuous stream of gas, whereas the current CDRA produces CO₂ in a batch process.

- The CO₂ must be desorbed at reduced pressure, then compressed for storage, then brought back again to reduced pressure to feed into the Sabatier process.
- Water must be stripped from the cabin air in the first step of the CDRA, even though the Sabatier process is water-tolerant (as water is produced by the process)
- >99% pure CO₂ is created by the CDRA, yet impurities such as nitrogen are tolerable by the Sabatier process.²¹ If the methane reduction product is to be kept on board the ship (as is being planned for future long-term missions), there is no need to purify gas to this level.

All of these opposing processes cost energy, despite the fact that they may not be technically necessary. The thermodynamic work of purification of CO₂ from air is represented by the equation:²²

$$W_{\min} = -\frac{RT_0}{\theta} \left(\ln\left(\frac{1}{x_{CO_2}}\right) + \frac{(1-\theta)x_{CO_2}}{x_{CO_2}} \ln\left(\frac{1}{(1-\theta)x_{CO_2}}\right) + (1-\theta)\ln((1-\theta)x_{CO_2}) \right)$$

where R is the universal gas constant; T₀ is the temperature of operation, θ is the fraction of CO₂ to be captured, and x_{CO₂} is the partial pressure of CO₂ in the air. The minimum work of concentrating CO₂ from 0.5% to 90% is 16.8 kJ/mol CO₂, or about 100 Wh/kg CO₂. By contrast, the CDRA on the ISS consumes 2174 Wh/kg. The feed unit to the Sabatier process thus works at <5% thermodynamic efficiency, even though the zeolite CO₂ capture process alone (without consideration of drying) works close to 20% thermodynamic efficiency.

A replacement process for the existing CDRA would ideally work as follows:

- It would provide a continuous stream of CO₂, to match the requirements of the Sabatier reactor and other CO₂ reduction processes.
- It would apply energy only to the CO₂, and not waste energy treating inert materials such as water.
- It would not concentrate the CO₂ beyond what is required to maintain the exothermic reaction in the Sabatier process and other CO₂ reduction processes.
- It would require minimal additional infrastructure such as large heaters and compressors.

It is the purpose of this research program to develop such a process and the purpose of this Phase I effort to demonstrate the proof of concept of using eSionic composite liquid membrane with CO₂ carrier species for air purification. A summary of the improvements made possible by switching from existing CDRA technology to eSionic's electrochemical approach is presented in Table 2 below. Estimates of energy consumption for eSionic's process assume equivalent thermodynamic performance to carbon sorption by zeolites, with elimination of the drying step. The size and weight estimates are made leveraging the results of this program, as well as previous work²³ on the throughput and efficiency possible with electrochemical membranes, with slightly more conservative assumptions. eSionic's system will use no consumables. Its reliability, while yet to be characterized, is expected to be superior to the alternatives because it requires no moving parts or thermal cycles, and will be the subject of Phase II of this program.

Table 2. A summary of improvements obtainable by switching from today's CDRA to eSionic's electrochemical membrane system

CO₂ purification technique	Energy consumption	Size	Weight	Consumables	Reliability
CDRA + accumulator	12-15 kWh/day	~500 L	>200 kg	None	2 year life specification
eSionic (practical targets)	3 kWh/day	~100 L	~50 kg	None	TBD [Phase II]

Conclusions

Phase I demonstrated the functionality of eSionic’s approach to CO₂ separation: we have established that CO₂ can be removed from simulated cabin air using only electrical input, by a film in a membrane configuration. Membrane synthesis and fabrication techniques were developed that allowed for the successful incorporation and retention of an electrochemically active carrier molecule with eSionic’s composite liquid membrane technology. This allowed for the successful demonstration of a continuous CO₂ capture rate at 40% in a single step with no moving parts. Higher capture rates of 80% was also demonstrated in a batch mode during this phase, showing the feasibility of this technology for highly efficient, low energy separation of CO₂ in space exploration activities. Based on these results and efforts during this phase of the program, it is projected that this technology has the potential of replacing the current CRDA on-board ISS with an operational energy savings of 80% in a weight and size footprint that is 75% smaller. eSionic’s key enabling technology – composite liquid membrane materials – allows creation of a functional electrochemical membrane in a thin film form factor that enables this technology and application.

The next step in the development is to improve the reliability of electrochemical membranes such that they can be deployed in the field. In Phase II, we will demonstrate the reliability of our system to continuous operation in humid air and we will develop a full system for a prototype air purifier.

References

- ¹ Roda Bounaceur, Nancy Lape, Denis Roizard, Cécile Vallieres, Eric Favre, Membrane processes for post-combustion carbondioxidecapture: A parametric study, *Energy*, Volume 31, Issue 14, November 2006, Pages 2556–2570
- ² Frank Zeman, Energy and Material Balance of CO2 Capture from Ambient Air, *Environ. Sci. Technol.*, 2007, 41 (21), pp 7558–7563
- ³ Ward, W. J. "Electrically induced carrier transport." (1970): 162-163.
- ⁴ Kang, M. P., and J. Winnick. "Concentration of carbon dioxide by a high-temperature electrochemical membrane cell." *Journal of applied electrochemistry* 15.3 (1985): 431-439.
- ⁵ D. L. DuBois, A. Miedaner, W. Bell, and J. C. Smart, in *Electrochemical and Electrocatalytic Reactions of Carbon Dioxide*, B. P. Sullivan, K. Krist, and H. E. Guard, Editors, p. 94, Elsevier Science Publishers B. V., Amsterdam (1993).
- ⁶ D. L. DuBois, A. Miedaner, W. Bell, and J. C. Smart, in *Electrochemical and Electrocatalytic Reactions of Carbon Dioxide*, B. P. Sullivan, K. Krist, and H. E. Guard, Editors, p. 94, Elsevier Science Publishers B. V., Amsterdam, 1993
- ⁷ Paul Scovazzo, Joe Poshusta, Dan DuBois, Carl Koval, and Richard Noble, Electrochemical Separation and Concentration of <1% Carbon Dioxide from Nitrogen, *Journal of The Electrochemical Society*, 150(5) D91-D98, 2003
- ⁸ Ward, W. J. "Analytical and experimental studies of facilitated transport." *AIChE Journal* 16.3 (1970): 405-410.
- ⁹ Bdzil, J., et al. "Analysis of potential difference in electrically induced carrier transport systems." *The Journal of Physical Chemistry* 77.6 (1973): 846-850.
- ¹⁰ Athayde, Amulya L., and Cornelius F. Ivory. "Electrical pumping in carrier-mediated membrane transport." *Journal of membrane science* 24.3 (1985): 309-323.
- ¹¹ Jemaa, N., et al. "Electrochemically modulated equilibrium stage processes." *Chemical engineering science* 46.4 (1991): 1017-1026.
- ¹² Way, J. Douglas, et al. "Liquid membrane transport: a survey." *Journal of Membrane Science* 12.2 (1982): 239-259.
- ¹³ <http://ion-engineering.com/2010/07/07/ion-awarded-doe-funding-for-co2-capture-field-test/>, accessed 4/12/15

-
- ¹⁴ Hasib-ur-Rahman, M., M. Sijaj, and F. Larachi. "Ionic liquids for CO₂ capture— Development and progress." *Chemical Engineering and Processing: Process Intensification* 49.4 (2010): 313-322.
- ¹⁵ AlNashef, Inas M., et al. "Electrochemical generation of superoxide in room-temperature ionic liquids." *Electrochemical and Solid-State Letters* 4.11 (2001): D16-D18.
- ¹⁶ Reysa, Richard P., et al. "International Space Station (ISS) Carbon Dioxide Removal Assembly (CDRA) Desiccant/Adsorbent Bed (DAB) Orbital Replacement Unit (ORU) Redesign." (2007).
- ¹⁷ Meyers, John T. James Valerie E., et al. "Crew Health and Performance Improvements with Reduced Carbon Dioxide Levels and the Resource Impact to Accomplish Those Reductions." (2011).
- ¹⁸ Perry, Jay L., Robert M. Bagdigian, and Robyn L. Carrasquillo. "Trade Spaces in Crewed Spacecraft Atmosphere Revitalization System Development." (2010).
- ¹⁹ Tobias, Barry, J. D. Garr II, and Meghan Erne. "International Space Station Water Balance Operations." (2011).
- ²⁰ Abney, Morgan B., and J. Matthew Mansell. "Evaluation of Bosch-Based Systems Using Non-Traditional Catalysts at Reduced Temperatures." In *41st International Conference on Environmental Systems*, pp. 17-21. 2011.
- ²¹ Hoekman, S. Kent, Amber Broch, Curtis Robbins, and Richard Purcell. "CO₂ recycling by reaction with renewably-generated hydrogen." *International Journal of Greenhouse Gas Control* 4, no. 1 (2010): 44-50.
- ²² Michael Matuszewski (contact), "Research and Development Goals for CO₂ Capture Technology", DOE/NETL-2009/1366, December 13, 2011, accessed online 4/16/13 from <http://www.netl.doe.gov/technologies/coalpower/ewr/co2/pubs/EPEC%20CO2%20Program%20Goals%20Final%20Draft%20v40409.pdf>
- ²³ Michael C. Stern, Fritz Simeon, Kristin Vicari, Thomas Hammer, Harald Landes, Howard Herzog, T. Alan Hatton, "Electrochemically-Mediated Separations for Carbon Mitigation" retrieved from <http://www.netl.doe.gov/publications/proceedings/11/co2capture/Posters/Poster-Stern-MIT-Electrochemically-MediatedSeparations.pdf>, 4/19/13