

## Packing Up For The Moon

### Human Exploration Project Engineering Design Challenge

A Standards-Based Middle School Unit Guide



## Packing Up For The Moon

### Design and Evaluate

**International Technology Education Association**  
Center to Advance the Teaching of Technology & Science

Inspiration + Innovation + Discovery = Future

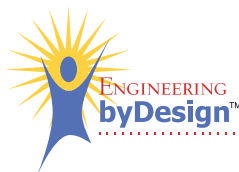
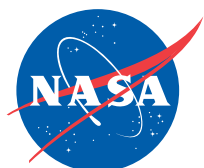

# ***Preface***

## **Packing Up for the Moon A Standards-Based Middle School Unit**

**1**

*Packing up  
for the  
Moon*

*Preface*

### **Acknowledgements**

Many individuals committed to developing middle school technological literacy made this publication possible. Their strong commitment to developing standards-based technology resources is reflected in this guide. Special thanks are expressed to:

Aaron Gray, Lead Author, Technology Education Teacher and Former Science Teacher  
Burleigh Manor Middle School, Ellicott City, Maryland

Kathleen Tunney, Science Integration Author, Science Teacher  
Burleigh Manor Middle School, Ellicott City, Maryland

Tony Micelli, Mathematics Integration Author, Mathematics Teacher  
Burleigh Manor Middle School, Ellicott City, Maryland

Kendall N. Starkweather, Ph.D., DTE, Executive Director  
International Technology Education Association (ITEA), Reston, Virginia

Barry N. Burke, DTE, Director  
ITEA-Center to Advance the Teaching of Technology and Science (CATTS), Reston, Virginia

Shelli D. Meade, Research Projects Director, Editor  
ITEA-CATTS, Christiansburg, Virginia

Robert C. Gray, DTE, Consultant  
University of Maryland Eastern Shore, Princess Anne, Maryland

William E. Dugger, Jr., Ph.D., DTE, Senior Fellow  
ITEA-Technology for All Americans Project (TfAAP), Blacksburg, Virginia

Engstrom Consulting Services, Layout  
West Newton, Pennsylvania

**Reviewers**

Special thanks are extended to the following expert and field reviewers who provided valuable feedback in the development of this resource.

William E. Dugger, Jr., DTE  
ITEA Fellow  
Blacksburg, VA

Michael Foley  
Levy Middle School  
Fellows Avenue and Harvard Place  
Syracuse, NY

Gerard Greer  
Melrose Veterans Memorial  
Middle School  
Melrose, MA

Tony Micelli  
Mathematics Teacher  
Burleigh Manor Middle School  
Ellicott City, MD

Bart Smoot  
Technology Education/Business/  
Computer Literacy Teacher  
Delmar Middle and High Schools  
Delmar, DE

Joanne Trombley  
J.R. Fugett Middle School  
West Chester, PA

Kathleen Tunney  
Science Teacher  
Burleigh Manor Middle School  
Ellicott City, MD

**Engineering byDesign™ Curriculum Specialists**

The Curriculum Specialists listed below have been trained to deliver workshops related to all EbD™ curriculum. For more information, see [www.engineeringbydesign.org](http://www.engineeringbydesign.org) or email [ebd@iteaconnect.org](mailto:ebd@iteaconnect.org).

Daniel W. Caron, DTE  
Kingswood Regional High School  
Wolfeboro, NH

Jenny L. Daugherty  
University of Illinois  
Urbana-Champaign, IL

Amy N. Gensemer  
Clarksburg High School  
Clarksburg, MD

Aaron M. Gray  
Burleigh Manor Middle School  
Ellicott City, MD

John W. Hansen, DTE  
The University of Texas at Tyler  
Tyler, TX

Courtney Phelps  
Lakelands Park Middle School  
Gaithersburg, MD

# The ITEA-CATTS Human Exploration Project (HEP)

## *People, Education and Technology*

3

*Packing up  
for the  
Moon*

*Preface*

In May 2005, ITEA was funded by the National Aeronautics and Space Administration (NASA) to develop curricular units for Grades K-12 on Space Exploration. The units focus on aspects of the themes that NASA Engineers and Scientists—as well as future generations of explorers—must consider, such as Energy and Power, Transportation and Lunar Plant Growth Chambers (the STS-118 Design Challenges). Moreover, the units are embedded within a larger model program for technology education known as Engineering byDesign™.

The Human Exploration Project (HEP) units have several common characteristics. All units:

- Are based upon the Technological Literacy standards (ITEA, 2000/2002).
- Coordinate with Science (AAAS, 1993) and Mathematics standards (NCTM, 2000).
- Utilize a standards-based development approach (ITEA, 2005).
- Stand alone and coordinate with ITEA-CATTS Engineering byDesign™ curricular offerings.
- Reflect a unique partnership between NASA scientists and engineers and education professionals.
- Incorporate leading-edge insight and practical experiences for students on how NASA works and plans.

These unit guides are designed to be practical and user-friendly. ITEA welcomes feedback from users in the field as we continually refine these curricular products, ensuring that the content remains as dynamic as the technological world in which we live. Please email [ebd@iteaconnect.org](mailto:ebd@iteaconnect.org) or call 703-860-2100.

# Packing Up for the Moon

## Table of Contents

Unit Resource Quick Links..... iii

### Packing Up for the Moon A Standards-Based Middle School Unit

#### Unit Overview

Standards .....	1
Benchmarks.....	1
Big Idea.....	1
Purpose of Unit.....	2
Unit Objectives .....	2

### Lesson 1: Identifying Criteria and Constraints

#### Lesson Snapshot

Overview.....	4
Activity Highlights .....	4

#### Lesson 1: Overview

Lesson Duration.....	5
Standards/Benchmarks .....	5
Learning Objectives.....	6
Student Assessment Tools and/or Methods .....	6
Resource Materials .....	8

#### Lesson 1: Modified 5-E Lesson Plan

Engagement .....	9
Exploration .....	9
Explanation.....	9
Extension .....	10
Evaluation .....	10
Enrichment.....	10

#### Lesson 1: Lesson Preparation

Teacher Planning.....	12
Tools/Materials/Equipment.....	12
Classroom Safety and Conduct .....	12

### Lesson 2: Let's Design

#### Lesson Snapshot

Overview.....	13
Activity Highlights .....	13

#### Lesson 2: Overview

Lesson Duration.....	14
----------------------	----

Engineering byDesign™

A National, Standards-Based Model for K–12 Technological Literacy

# Packing Up for the Moon

Standards/Benchmarks .....	14
Learning Objectives.....	14
Resource Materials .....	17
<b>Lesson 2: Modified 5-E Lesson Plan</b>	
Engagement .....	18
Exploration .....	18
Explanation.....	18
Extension .....	19
Evaluation .....	19
Enrichment.....	19
<b>Lesson 2: Lesson Preparation</b>	
Teacher Planning.....	20
Tools/Materials/Equipment.....	20
Classroom Safety and Conduct .....	20
<b>Lesson 3: Developing and Sharing the Design</b>	
<b>Lesson Snapshot</b>	
Overview.....	21
Activity Highlights .....	21
<b>Lesson 3: Overview</b>	
Lesson Duration.....	22
Standards/Benchmarks .....	22
Learning Objectives.....	22
Student Assessment Tools and/or Methods.....	23
Resource Materials .....	25
<b>Lesson 3: Modified 5-E Lesson Plan</b>	
Engagement .....	26
Exploration .....	26
Explanation.....	26
Extension .....	27
Evaluation .....	27
<b>Lesson 3: Lesson Preparation</b>	
Teacher Planning.....	28
Tools/Materials/Equipment.....	28
Classroom Safety and Conduct .....	28
<b>References</b>	
<b>Appendices Resource Documents</b>	

# *Packing Up for the Moon*

## Unit Resource Quick Links

*Moon ABCs Fact Sheet*

*Understanding the Role of  
Plants in a Lunar Base*

*KWL Chart*

*Design Brief*

*Engineering Design Process*

*Lunar Plant Growth Chamber  
Design Steps*

*Sketching and Drawing*

# Packing Up for the Moon

## A Standards-Based Middle School Unit

1

*Packing  
Up for the  
Moon*

*Unit  
Overview*

### Unit Overview

Design is a creative problem-solving process that leads to the development of new products and systems. In this unit, students will learn about and apply this process in developing a lunar plant growth chamber design. The criteria and constraints for this system are based on the unique conditions of the lunar environment and the current transportation technologies available. The current focus of NASA is reviewed as well as the new systems that are being developed for future missions. The science of the lunar environment and basic plant needs are presented.

*Teacher's Note:* Big ideas should be made explicit to students by writing them on the board and/or reading them aloud.

#### *Big Idea*

*Design is a creative planning process that leads to useful products and systems.*

### Standards

*Technology:* Standards for Technological Literacy (STL) (ITEA, 2000/2002)

- Students will develop an understanding of the characteristics and scope of technology. (ITEA/STL 3)
- Students will develop an understanding of the attributes of design. (ITEA/STL 8)
- Students will develop an understanding of engineering design. (ITEA/STL 9)
- Students will develop an understanding of the role of troubleshooting, research and development, invention and innovation and experimentation in problem solving. (ITEA/STL 10)
- Students will develop the abilities to apply the design process. (ITEA/STL 11)
- Students will develop the abilities to use and maintain technological products and systems. (ITEA/STL 12)

*Science:* Benchmarks for Science Literacy (AAAS, 1993)

- The Nature of Technology/Technology and Science (AAAS 3A)
- The Physical Setting/The Earth (AAAS 4B)
- The Living Environment/Flow of Matter and Energy (AAAS 5E)
- The Human Organism/Basic Functions (AAAS 6C)

*Mathematics:* Principles and Standards for School Mathematics (NCTM, 2000)

- Measurement
- Representation

### Benchmarks

*Technology:* Standards for Technological Literacy (STL) (ITEA, 2000/2002)

- Management is the process of planning organizing and controlling work. (ITEA/STL 3EE)
- Design is a creative planning process that leads to useful products and systems. (ITEA/STL 8E)
- There is no perfect design. (ITEA/STL 8F)
- Requirements for a design are made up of criteria and constraints. (ITEA/STL 8G)
- Brainstorming is a group problem-solving design process in which each person in the group presents his or her ideas in an open forum. (ITEA/STL 9G)
- Modeling, testing, evaluating and modifying are used to transform ideas into practical solutions. (ITEA/STL 9H)

*Middle School; Packing Up for the Moon*



- Invention is a process of turning ideas and imagination into devices and systems. Innovation is the process of modifying an existing product or system to improve it. (ITEA/STL 10G)
- Apply a design process to solve problems in and beyond the laboratory-classroom. (11-H)
- Specify criteria and constraints for the design. (ITEA/STL 11I)
- Make two-dimensional and three-dimensional representations of the designed solution. (ITEA/STL 11J)
- Test and evaluate the design in relation to pre-established requirements, such as criteria and constraints and refine as needed. (ITEA/STL 11K)
- Make a product or system and document the solution. (ITEA/STL 11L)
- Use computers and calculators in various applications. (ITEA/STL 12J)

*Science:* Benchmarks for Science Literacy (AAAS, 1993)

- Engineers, architects and others who engage in design and technology use scientific knowledge to solve practical problems, but they usually have to take human values and limitations into account as well. (AAAS 3A)
- The moon's orbit around the earth once in about 28 days changes what part of the moon is lighted by the sun and how much of that part can be seen from the earth—the phases of the moon. (AAAS 4B)
- Energy can change from one form to another in living things. Animals get energy from oxidizing their food, releasing some of its energy as heat. Almost all food energy comes originally from sunlight. (AAAS 5E)
- To burn food for the release of energy stored in it, oxygen must be supplied to cells and carbon dioxide removed. Lungs take in oxygen for the combustion of food and they eliminate the carbon dioxide produced. (AAAS- 6C)

*Mathematics:* Principles and Standards for School Mathematics (NCTM, 2000)

- Use representations to model and interpret physical, social and mathematical phenomena. (NCTM Representation)
- Solve problems involving scale factors, using ratio and proportion. (NCTM Measurement)
- Develop and use formulas to determine the circumference of circles and the area of triangles, parallelograms, trapezoids and circles and develop strategies to find the area of more complex shapes. (NCTM Measurement)
- Understand relationships among units and convert from one unit to another within the same system. (NCTM Measurement)

## Purpose of Unit

This unit introduces students to the engineering challenges involved in supporting a sustained, human presence on the lunar surface.

## Unit Objectives

### Lesson 1: Identifying Criteria and Constraints

Students will:

- Explain how invention and innovation relate to the development of new products, processes and systems.
- Identify criteria and constraints related to the design and development of a lunar plant growth chamber on the lunar surface.
- Explain that requirements for a design are made up of criteria and constraints.
- Explain why there is no perfect design.
- Explain that an organism uses oxygen to burn food to release energy and that the energy was originally from sunlight.

- Identify the four main goals in the Vision for Space Exploration.
- Determine the approximate ratio of two areas.

### *Lesson 2: Let's Design*

Students will:

- Explain that design is a creative planning process that leads to useful products and systems.
- Identify criteria and constraints related to the design and development of a plant growth chamber on the lunar surface.
- Apply the engineering design process to solve a problem.
- Identify and describe the major steps in the engineering design process.
- Explain that brainstorming is a group problem-solving design process in which each person in the group presents his or her ideas in an open forum.
- Use criteria and constraints related to the design and development of a plant growth chamber to brainstorm possible design solutions.
- Analyze possible solutions to the design challenge.
- Select an approach to the design challenge.

### *Lesson 3: Developing and Sharing the Design*

Students will:

- Develop a design proposal for a lunar plant growth chamber.
- Develop a production plan for a prototype lunar plant growth chamber.
- Explain that management is the process of planning organizing and controlling work.
- Describe how modeling, testing, evaluating and modifying are used to transform ideas into practical solutions.
- Make two-dimensional and three-dimensional representations of the designed solution.
- Apply the engineering design process to solve a problem.

# Lesson 1: Identifying Criteria and Constraints

4

## Lesson Snapshot

*Packing  
Up for the  
Moon*

*Lesson 1  
Identifying  
Criteria and  
Constraints*

### Overview

**Big Idea:** Design is a creative planning process that leads to useful products and systems.

**Teacher's Note:** Big ideas should be made explicit to students by writing them on the board and/or reading them aloud.

**Purpose of Lesson:** This lesson prepares students to identify the requirements for the design and development of a plant growth chamber on the lunar surface.

**Lesson Duration:** Two hours.

### Activity Highlights

**Engagement:** The teacher asks students, working in pairs, to speculate on whether plants can grow on the moon.

**Exploration:** The teacher displays a plant or an image of a plant and asks students to list the conditions required for the plant's growth. Students identify the role of plants in our ecosystem. Students read *Moon ABCs Fact Sheet* and answer selected questions.

**Explanation:** The students view *Into The Cosmos*. The teacher describes the benefits of growing plants in space for astronauts on extended missions. The teacher describes characteristics of invention and innovation and how requirements affect design.

**Extension:** Students, working in design teams of two to four, identify criteria and constraints for a plant growth chamber to be used on the moon.

**Evaluation:** Student knowledge, skills and attitudes are assessed using brief constructed response items and selected response items as well as optional rubrics for class participation.

## Lesson 1: Overview

5

*Packing  
Up for the  
Moon*

*Lesson 1  
Identifying  
Criteria and  
Constraints*

### Lesson Duration

- Two hours.

### Standards/Benchmarks

*Technology: Standards for Technological Literacy (ITEA, 2000/2002)*

- Students will develop an understanding of the attributes of design. (ITEA/STL 8)
  - Design is a creative planning process that leads to useful products and systems. (ITEA/STL 8E)
  - There is no perfect design. (ITEA/STL 8F)
  - Requirements for a design are made up of criteria and constraints. (ITEA/STL 8G)
- Students will develop an understanding of engineering design. (ITEA/STL 9)
  - Brainstorming is a group problem-solving design process in which each person in the group presents his or her ideas in an open forum. (ITEA/STL 9G)
- Students will develop an understanding of the role of troubleshooting, research and development, invention and innovation and experimentation in problem solving. (ITEA/STL 10)
  - Invention is a process of turning ideas and imagination into devices and systems. Innovation is the process of modifying an existing product or system to improve it. (ITEA/STL 10G)
- Students will develop the abilities to apply the design process. (ITEA/STL 11)
  - Specify criteria and constraint for the design. (ITEA/STL 11I)

*Science: Benchmarks for Science Literacy (AAAS, 1993)*

- The Nature of Technology/Technology and Science (AAAS 3A)
  - Engineers, architects and others who engage in design and technology use scientific knowledge to solve practical problems, but they usually have to take human values and limitations into account as well. (AAAS-3A)
- The Physical Setting/The Earth (AAAS 4B)
  - The moon's orbit around the earth once in about 28 days changes what part of the moon is lighted by the sun and how much of that part can be seen from the earth-the phases of the moon. (AAAS-4B)
- The Living Environment/Flow of Matter and Energy (AAAS 5E)
  - Energy can change from one form to another in living things. Animals get energy from oxidizing their food, releasing some of its energy as heat. Almost all food energy comes originally from sunlight. (AAAS-5E)
- The Human Organism/Basic Functions (AAAS 6C)
  - To burn food for the release of energy stored in it, oxygen must be supplied to cells and carbon dioxide removed. Lungs take in oxygen for the combustion of food and they eliminate the carbon dioxide produced. (AAAS- 6C)

*Mathematics: Principles and Standards for School Mathematics (NCTM, 2000)*

- Representation
  - Use representations to model and interpret physical, social and mathematical phenomena.
- Measurement
  - Solve problems involving scale factors, using ratio and proportion.

**Learning Objectives**

Students will:

1. Explain how invention and innovation relate to the development of new products, processes and systems.
2. Identify criteria and constraints related to the design and development of a plant growth chamber on the lunar surface.
3. Explain that requirements for a design are made up of criteria and constraints.
4. Explain why there is no perfect design.
5. Explain that an organism uses oxygen to burn food to release energy and that the energy was originally from sunlight.
6. Identify the four main goals in the Vision for Space Exploration.
7. Determine the approximate ratio of two areas.

**Student Assessment Tools and/or Methods**

1. Selected Response Items

T	F	1.	Criteria are drawings used to represent the solution to a design challenge.
T	F	2.	Constraints are limits related to the design of a technology system.
T	F	3.	Plants convert oxygen to carbon dioxide through a process called transpiration.
T	F	4.	Requirements are made up of criteria and constraints.
T	F	5.	A design can be perfect if tested and refined thoroughly.
T	F	6.	Plants produce more food and oxygen when the light intensity is increased.
T	F	7.	The Vision for Space Exploration includes returning humans to the moon.
T	F	8.	Invention is the improvement of an existing system.
T	F	9.	The heart takes in oxygen for the combustion of food and eliminates the carbon dioxide produced.
T	F	10.	Energy can change from one form to another in living things.

## 2. Optional Rubric for Class Participation

*Teacher's Note:* Teachers may choose to use this rubric as a way to assess students, with or without making it a basis for student grades.

Category	Below Target	At Target	Above Target
<b>Preparation</b>	Rarely prepared. Minimal effort to participate.	Prepared for class. Attempts to answer teacher-generated questions.	Well prepared for class. Attempts to answer teacher-generated questions and adds additional information to class when relevant.
<b>Curiosity</b>	Rarely demonstrates curiosity.	Usually demonstrates curiosity.	Consistently demonstrates curiosity.
<b>Motivation for Learning</b>	Rarely demonstrates motivation for learning.	Usually demonstrates motivation for learning.	Consistently demonstrates motivation for learning.
<b>Use of Time</b>	Gives up easily; is not engaged. Has difficulty remaining on task.	Makes good use of class time to work on assignments and projects.	Makes excellent use of class time to work on assignments and projects.

## 3. Rubric for Brief Constructed Response Item

Explain how astronauts would benefit by having a small lunar plant growth chamber on an extended (3 month +) expedition on the moon's surface.

Category	Below Target	At Target	Above Target
<b>Understanding</b>	Response demonstrates an implied, partial or superficial understanding of the question.	Response demonstrates an understanding of the question.	Response demonstrates an understanding of the complexities of the concept.
<b>Focus</b>	Lacks transitional information to show the relationship of the support to the question.	Addresses the demands of the question.	Exceeds the demands of the question.
<b>Use of Related Information</b>	Uses minimal information from the lesson to clarify or extend meaning.	Uses some expressed or implied information from the lesson to clarify or extend meaning.	Effectively uses expressed or implied information from the lesson to clarify or extend meaning.

## Resource Materials

### Print Materials

1. *Teachers and students investigating plants in space: A teacher's guide with activities for life sciences* (EG-1997-02-113-HQ). (1997). ASIN: B000H48XM6. Retrieved July 6, 2007 from <http://education.nasa.gov/edprograms/core/home/index.html>
2. *Fundamentals of space biology: research on cells, animals and plants in space* New York: Springer.
3. Pierce, A. & Karwatka, D. (1999). *Introduction to technology*. New York: Glencoe/McGraw-Hill, (pp. 157-180).

### Audiovisual Materials

1. *NASA connect - functions and statistics - International Space Station - Up to us*. (n.d.). Retrieved July 6, 2007 from <http://www.open-video.org/details.php?videoid=6311>
2. *JFK moon speech at Rice University*. (1962, November 12). Retrieved from <http://www1.jsc.nasa.gov/er/seh/ricetalk.htm>

### Internet Sites

1. *Into the cosmos*. (n.d.) Retrieved July 6, 2007 from <http://www.nasa.gov/multimedia/video-gallery/index.html>
2. *Exploring the moon: A teacher's guide with activities* (pp. 17-18). (1997). Retrieved on July 6, 2007 from <http://ares.jsc.nasa.gov/Education/Activities/ExpMoon/MoonFactSheet.pdf>
3. *Educational plant growth hardware* (Space Garden and BPSe). (n.d.). Retrieved July 6, 2007 from <http://www.orbitec.com/outreach/index.htm>
4. *Space agriculture in the classroom* (n.d.). Retrieved July 6, 2007 from <http://www.spaceag.org/>

## Lesson 1: Modified 5-E Lesson Plan

9

*Packing  
Up for the  
Moon*

*Lesson 1  
Identifying  
Criteria and  
Constraints*

### Engagement

*Teacher's Note:* See **Enrichment** below for an opportunity to enhance the **Engagement** if time allows.

1. The teacher shows the students a picture or pictures of the moon.
2. The teacher asks the students, working in pairs, to speculate on whether plants can grow on the moon.
3. The teacher solicits brief responses from students and points out that most answers begin with “Yes, if” or “No, because.”

### Exploration

1. The teacher displays a plant or an image of a plant that grows in the local Earth environment and then asks students to list the conditions required for the plant's growth.
2. The teacher asks students to work with their neighbors to make a list of the roles that plants play in Earth's ecosystem.
3. Students read *Moon ABCs Fact Sheet* and record brief answers to each question.
4. Students report on the requirements for growing plants on the moon.

### Explanation

1. The teacher facilitates a discussion of the requirements for plant growth on the moon. The teacher asks students:
  - What would we need to need to “bring along”?
2. The teacher shows the video clip, *Into the Cosmos*. (See References page 29)
  - Prior to viewing, the teacher explains that the speech was given on January 14, 2004 during the investigation of the Space Shuttle Columbia disaster.
  - After viewing the video clip, the teacher asks students to identify the four main goals in the Vision for Space Exploration.
    1. Return the space shuttle to regular service.
    2. Complete the International Space Station by 2010.
    3. Develop and use the Crew Exploration Vehicle to return humans to the moon.
    4. Explore Mars and beyond.
3. The teacher explains that astronauts on extended missions could benefit by having live plants with them to:
  - Provide food.
  - Provide oxygen.
  - Purify water.
  - Provide a psychological lift—provide “sense of home.”
4. The teacher explains how food and energy provided by plants provide energy for astronauts.
  - Energy can change from one form to another in living things.
  - Animals get energy from oxidizing their food, releasing some of the energy as heat.
  - To burn food for the release of energy stored in it, oxygen must be supplied to cells and carbon dioxide removed.
  - Lungs take in oxygen for the combustion of food and they eliminate the carbon dioxide produced.



5. The teacher explains that requirements are made up of criteria and constraints.
  - *Criteria* are specific outcomes for a project. “What do you want it to do?” and “How well do you want it to be done?”
  - *Constraints* are limits. These are based on the resources available (time, tools and machines, materials, capital, people, information, energy and time) and the environment in which the solution must exist.
6. The teacher explains that there is no perfect design. Different solutions may satisfactorily solve a problem, but no one solution is perfect. The best designs optimize the desired qualities—safety, reliability, economy and efficiency—within the given constraints.
7. The teacher explains that invention and innovation relate to the development of new products, processes and systems.
  - Invention is the creation of a new system.
  - Innovation is the improvement of an existing system.
  - Both invention and innovation require creativity and perseverance.
  - Both invention and innovation serve the purpose of satisfying the needs and wants of people, society and industry.

### Extension

*Teacher’s Note:* See **Enrichment** below for a way to enhance the **Extension**, if time allows.

1. In groups of two or four, students form design teams.
2. The design teams use *Understanding the Role of Plants in a Lunar Base* to examine and identify criteria for a lunar plant growth chamber.

### Evaluation

Student knowledge, skills and attitudes are assessed using selected response items and rubrics for class participation, brief constructed responses and the oral presentation. The rubrics are presented in advance of the activities to familiarize students with the expectations and performance criteria. They are also reviewed during the activities to guide students in completing assignments. The teacher may wish to develop a collection of annotated exemplars of student work based on the rubrics. The exemplars serve as benchmarks for future assessments and may be used to familiarize students with the criteria for assessment.

### Enrichment

The teacher may choose to use the following activities to enhance and extend the lesson. Activity 1 may be used as a warm-up to Lesson 1 as a whole by using it as **Engagement** or Activity 1 may be used as an introduction to the **Extension** portion of Lesson 1.

1. The teacher asks students to write their thoughts about the following:
  - What portion of the student body of this school are boys?
  - What are some different ways we could express our answer?

The teacher asks students to share their ideas and discuss the different ways the answers could be expressed. The teacher asks students to think about and write an answer for the following:

- How could we use data from this class to estimate the number of boys in the school?

The teacher asks students to share their ideas and solutions.

2. The teacher examines the International Space Station using the NASA Connect Video – Functions and Statistics: International Space Station (<http://www.open-video.org/details.php?videoid=6311>). Then, the teacher prints the educator’s guide from [http://connect.larc.nasa.gov/connect\\_bak/pdf/00\\_5.pdf](http://connect.larc.nasa.gov/connect_bak/pdf/00_5.pdf) and makes copies of the student cue cards (pg 14). The following video time segments may be used in class to discuss and answer questions regarding the construction and use of the space station: 0:00–11:00 and 18:35–28:30.
3. The teacher shows students the video clip “JFK Moon Speech at Rice University, 11/12/62” from <http://www1.jsc.nasa.gov/er/seh/ricetalk.htm>. The teacher leads students in a discussion that compares and contrasts the messages, missions and settings between this and the [Into The Cosmos](#) speech by George Bush.

## Lesson 1: Lesson Preparation

12

*Packing  
Up for the  
Moon*

*Lesson 1  
Identifying  
Criteria and  
Constraints*

### Teacher Planning

The laboratory-classroom should provide a flexible, resource-rich learning environment that includes areas for lectures and demonstrations, small group meetings and research activities. The teacher adapts the learning environment based on the requirements of the unit or lesson. For this lesson, areas for lecture and demonstration, design, small group meetings and fabrication activities should be readied.

### Tools/Materials/Equipment

- Chalk board
- Teacher rubric included in lesson
- Copies of *Moon ABCs Fact Sheet* (one per pair of students)
- Copies of *Understanding the Role of Plants in a Lunar Base* (one per pair of students)
- Overhead projector
- Computer with Internet access, LCD projector and speakers
- Graph paper

### Classroom Safety and Conduct

1. Students demonstrate respect and courtesy for the ideas expressed by others in the class.
2. Students show respect and appreciation for the efforts of others.
3. Students use tools and equipment in a safe manner and assume responsibility for their safety as well as for the safety of others.

# Lesson 2: Let's Design

## Lesson Snapshot

13

*Packing  
Up for the  
Moon*

*Lesson 2  
Let's Design*

### Overview

**Big Idea:** Design is a creative planning process that leads to useful products and systems.

**Purpose of Lesson:** This lesson will guide students in using the engineering design process to design a plant growth chamber for use on the lunar surface.

**Lesson Duration:** Two hours.

### Activity Highlights

**Engagement:** Students use the *KWL Chart* to enhance their understanding of the requirements for a plant growth chamber for use on the lunar surface.

**Exploration:** Students read the design brief for the *Design Brief*. The teacher leads a discussion about the requirements and answers questions.

**Explanation:** The teacher shows students videos and/or images of the new vehicles designed for the Constellation Program. The teacher demonstrates design processes, including the development of two-dimensional and three-dimensional representations of design solutions.

**Extension:** Students, working in design teams, follow the engineering design process to develop two-dimensional and three-dimensional representations of a plant growth chamber for use on the lunar surface. Students select an approach to build.

**Evaluation:** Student knowledge, skills and attitudes are assessed using selected response items and rubrics for class participation and design development.

## Lesson 2: Overview

14

*Packing  
Up for the  
Moon*

*Lesson 2  
Let's Design*

### Lesson Duration

- Two hours.

### Standards/Benchmarks

*Technology: Standards for Technological Literacy (ITEA, 2000/2002)*

- Students will develop an understanding of the attributes of design. (ITEA/STL 8)
  - Design is a creative planning process that leads to useful products and systems. (ITEA/STL 8E)
- Students will develop an understanding of engineering design. (ITEA/STL 9)
  - Brainstorming is a group problem-solving design process in which each person in the group presents his or her ideas in an open forum. (ITEA/STL 9G)
  - Modeling, testing, evaluating and modifying are used to transform ideas into practical solutions. (ITEA/STL 9H)
- Students will develop the abilities to apply the design process. (ITEA/STL 11)
  - Specify criteria and constraints for the design. (ITEA/STL 11I)
  - Test and evaluate the design in relation to pre-established requirements, such as criteria and constraints and refine as needed. (ITEA/STL 11K)
- Students will develop the abilities to use and maintain technological products and systems. (ITEA/STL 12)
  - Use computers and calculators in various applications. (ITEA/STL 12J)

*Science: Benchmarks for Science Literacy (AAAS, 1993)*

- The Nature of Technology/Technology and Science (AAAS 3A)
  - Engineers, architects and others who engage in design and technology use scientific knowledge to solve practical problems, but they usually have to take human values and limitations into account as well. (AAAS-3A)

*Mathematics: Principles and Standards for School Mathematics (NCTM, 2000)*

- Measurement
  - Solve problems involving scale factors, using ratio and proportion.
  - Develop and use formulas to determine the circumference of circles and the area of triangles, parallelograms, trapezoids and circles and develop strategies to find the area of more-complex shapes.
- Representation
  - Use representations to model and interpret physical, social and mathematical phenomena.

### Learning Objectives

Students will:

1. Explain that design is a creative planning process that leads to useful products and systems.
2. Identify criteria and constraints related to the design and development of a plant growth chamber on the lunar surface.
3. Apply the engineering design process to solve a problem.
4. Identify and describe the major steps in the engineering design process.
5. Explain that brainstorming is a group problem-solving design process in which each person in the group presents his or her ideas in an open forum.

6. Use criteria and constraints related to the design and development of a plant growth chamber to brainstorm possible design solutions.
7. Analyze possible solutions to the design challenge.
8. Select an approach to the design challenge.

### Student Assessment Tools and/or Methods

1. Selected Response Items

		Column I	Column II
	1.	Defining the problem	a. thinking of and recording ideas
	2.	Brainstorming a solution	b. adjusting your solution based on evaluation
	3.	Generating ideas	c. limits placed on a design
	4.	Criteria	d. identifying needs and wants.
	5.	Constraints	e. identifying pros and cons of multiple solutions
	6.	Exploring possibilities	f. requirements for a design solution
	7.	Selecting an approach	g. creating accurate drawings of multiple possible solutions
	8.	Prototype	h. choosing a solution based on criteria and constraints
	9.	Evaluating the design	i. testing the design and collecting data
	10.	Refining the design	j. a working model of a design solution

Key: 1d, 2a, 3g, 4f, 5c, 6e, 7h, 8j, 9i, 10b

2. Rubric for Engineering Design Process (Lesson 2 Extension Activity—**Lunar Plant Growth Chamber Design Steps**)

Category	Below Target	At Target	Above Target
<b>Defining the Problem</b>	Rephrases the problem with limited clarity.	Rephrases the problem clearly.	Rephrases the problem clearly and precisely.
<b>Identifying Criteria and Constraints</b>	Does not restate the criteria clearly and fails to identify constraints.	Restates the criteria clearly and identifies several constraints.	Restates the criteria clearly and precisely and identifies many constraints.
<b>Brainstorming a Solution (Individual)</b>	Contributes few and/or implausible ideas or no ideas.	Contributes a plausible idea.	Contributes multiple, plausible ideas.
<b>Generating Ideas</b>	Contributes implausible ideas. Produces incomplete sketches. Does not present a concept.	Contributes one plausible idea. Produces marginally accurate pictorial and orthographic sketches of design concepts.	Contributes multiple plausible ideas. Produces accurate pictorial and orthographic sketches of design concepts.
<b>Exploring Possibilities</b>	Inadequately analyzes the pluses and minuses of a variety of possible solutions.	Satisfactorily analyzes the pluses and minuses of a variety of possible solutions.	Thoroughly analyzes the pluses and minuses of a variety of possible solutions.
<b>Selecting an Approach</b>	Selection of solution is not based on consideration of criteria and constraints.	Selects a promising solution based on criteria and constraints.	Selects a promising solution based on a thorough analysis criteria and constraints.

## 3. Optional Rubric for Class Participation

*Teacher's Note:* Teachers may choose to use this rubric as a way to assess students, with or without making it a basis for student grades.

Category	Below Target	At Target	Above Target
<b>Preparation</b>	Rarely prepared. Minimal effort to participate.	Prepared for class. Attempts to answer teacher-generated questions.	Well prepared for class. Attempts to answer teacher-generated questions and adds additional information to class when relevant.
<b>Curiosity</b>	Rarely demonstrates curiosity.	Usually demonstrates curiosity.	Consistently demonstrates curiosity.
<b>Motivation for Learning</b>	Rarely demonstrates motivation for learning.	Usually demonstrates motivation for learning.	Consistently demonstrates motivation for learning.
<b>Use of Time</b>	Gives up easily; is not engaged. Has difficulty remaining on task.	Makes good use of class time to work on assignments and projects.	Makes excellent use of class time to work on assignments and projects.
<b>Teacher Comment</b>			

## Resource Materials

### Print Materials

1. *Teachers and students investigating plants in ppace: A teacher's guide with activities for life sciences* (EG-1997-02-113-HQ). (1997). ASIN: B000H48XM6. Retrieved July 6, 2007 from <http://education.nasa.gov/edprograms/core/home/index.html>
2. *Fundamentals of space biology: research on cells, animals and plants in space* New York: Springer.
3. Pierce, A. & Karwatka, D. (1999). *Introduction to technology*. New York: Glencoe/McGraw-Hill, (pp. 157-180).

### Audiovisual Materials

1. *NASA connect - functions and statistics - International Space Station - Up to us*. (n.d.). Retrieved July 6, 2007 from <http://www.open-video.org/details.php?videoid=6311>
2. *JFK moon speech at Rice University*. (1962, November 12). Retrieved from <http://www1.jsc.nasa.gov/er/seh/ricetalk.htm>

### Internet Sites

1. Wilson, J. (Ed.). (2007 February 23). *Camping on the moon will be a far out experience*. (n.d.). Retrieved July 6, 2007 from [http://www.nasa.gov/mission\\_pages/exploration/mmb/inflatable-lunar-hab.html](http://www.nasa.gov/mission_pages/exploration/mmb/inflatable-lunar-hab.html)
2. *The Constellation Program – Videos, images and descriptions of the new spacecraft systems*. (n.d.). Retrieved March 1, 2007 from [http://www.nasa.gov/mission\\_pages/constellation/main/index.html](http://www.nasa.gov/mission_pages/constellation/main/index.html)



## Lesson 2: Modified 5-E Lesson Plan

18

*Packing  
Up for the  
Moon*

*Lesson 2  
Let's Design*

### Engagement

1. Students, working individually, use the *KWL Chart* to enhance their understanding of the requirements for a plant growth chamber to be used on the lunar surface.

### Exploration

1. The teacher distributes the *Design Brief*.
2. Student volunteers read the design brief aloud to the rest of the class.
3. Students return to their design teams from the previous lesson and compare their list of criteria to that presented in the design brief.
4. The teacher asks students to compare and contrast the two sets of criteria.
5. The teacher discusses and clarifies information in the design brief as needed.
6. Students complete the KWL process as they learn answers to their questions.

### Explanation

1. The teacher discusses the Constellation Program (the new vehicles and systems that will likely be used to transport humans to the moon and beyond) with the students. The teacher shows the video *Ares* "To the Moon and Beyond" is one of several videos and images that can be used to show the new systems. "Camping on the Moon" is a section that shows a proposed design for a moon outpost. (*Location can be found in the References section p.29*)
2. The teacher explains that:
  - Invention and innovation relate to the development of new products, processes and systems.
  - Brainstorming is a group problem-solving process in which each person in the group presents his or her ideas in an open forum. Ideas are to be recorded but not evaluated during this step. Drawings and lists are common ways to record design ideas.
  - Modeling, testing, evaluating and modifying are used to transform ideas into practical solutions.
3. The teacher reviews the basic steps of the *Engineering Design Process*.
  - Identify the problem
  - Identify criteria and constraints (requirements)
  - Brainstorm possible solutions
  - Generate ideas - develop multiple solutions
  - Explore possibilities – create a pro/con chart for each idea
  - Select an approach – based on requirements and pro/con chart
  - Make a model or prototype
  - Test and evaluate the design
  - Refine the design
4. The teacher asks students to draw and label three examples of a flat surface with an area of ten square feet. The teacher may choose to draw one example on the board to help students get started. The teacher demonstrates methods for solutions that involve the following steps:
  - Rectangles
  - Circles
  - Triangles
  - Combinations of the shapes above

**Extension**

Students work with their design teams to select an approach for a lunar plant growth chamber. This includes identifying the problem, identifying requirements, brainstorming, generating ideas and exploring possibilities. Students document their work using the resource, *Lunar Plant Growth Chamber Design Steps*.

**Evaluation**

Student knowledge, skills and attitudes are assessed using selected response items and rubrics for class participation and brief constructed responses. The rubrics are presented in advance of the activities to familiarize students with the expectations and performance criteria. They are also reviewed during the activities to guide students in the completion of assignments. The teacher may wish to develop a collection of annotated exemplars of student work based on the rubrics. The exemplars serve as benchmarks for future assessments and may be used to familiarize students with the criteria for assessment.

**Enrichment**

Students may read about and see more images of the components of the Constellation Program at [http://www.nasa.gov/mission\\_pages/constellation/main/index.html](http://www.nasa.gov/mission_pages/constellation/main/index.html). Students may be asked to identify old and current technology being applied to this new endeavor as well as the new systems being developed. Students may also be asked to identify mission components as expendable versus reusable.

## Lesson 2: Lesson Preparation

20

*Packing  
Up for the  
Moon*

*Lesson 2  
Let's Design*

### Teacher Planning

The laboratory-classroom should provide a flexible, resource-rich learning environment that includes areas for lectures and demonstrations, small group meetings and research activities. The teacher adapts the learning environment based on the requirements of the unit or lesson. For this lesson, areas for lecture and demonstration, design, small group meetings and fabrication activities should be readied.

### Tools/Materials/Equipment

- Chalkboard or overhead projector
- Computer with Internet access, LCD projector and speakers
- Sketching and Drawing Sheets (optional)
- Teacher rubric included in lesson

### Classroom Safety and Conduct

1. Students demonstrate respect and courtesy for the ideas expressed by others in the class.
2. Students show respect and appreciation for the efforts of others.
3. Students use tools and equipment in a safe manner and assume responsibility for their safety as well as for the safety of others.

# Lesson 3: Developing and Sharing the Design

## Lesson Snapshot

21

*Packing  
Up for the  
Moon*

*Lesson 3  
Developing  
and Sharing  
the Design*

### Overview

**Big Idea:** Design is a creative planning process that leads to useful products and systems.

**Purpose of Lesson:** Develop, analyze and refine a visual representation of a lunar plant growth chamber for use on the lunar surface.

**Lesson Duration:** Four hours.

### Activity Highlights

**Engagement:** Students identify ways in which the design solutions could be displayed.

**Exploration:** Students, working in design teams, develop detailed drawings of their lunar plant growth chamber, with parts and measurements labeled.

**Explanation:** The teacher explains how modeling, testing, evaluating and modifying are used to transform ideas into practical solutions. Students identify the value of conducting a design review before beginning the construction of a solution.

**Extension:** Students, working in design teams, conduct a design review, develop a fabrication plan and fabricate a prototype of a growth chamber to be used on the lunar surface, then, test, analyze and report.

**Evaluation:** Design teams present plans to other groups and make necessary adjustments. Upon completion, the design team develops a visual representation of detailed plans and shares the solution with the rest of the class. Students develop and analyze the presentation and present the solution to the class.

## Lesson 3: Overview

22

*Packing  
Up for the  
Moon*

*Lesson 3  
Developing and  
Sharing the  
Design*

### Lesson Duration

- Four hours.

### Standards/Benchmarks

*Technology: Standards for Technological Literacy (STL) (ITEA, 2000/2002)*

- Students will develop an understanding of the characteristics and scope of technology. (ITEA/STL 3)
  - Management is the process of planning organizing and controlling work. (ITEA/STL 3EE)
- Students will develop an understanding of engineering design. (ITEA/STL 9)
  - Modeling, testing, evaluating and modifying are used to transform ideas into practical solutions. (ITEA/STL 9H)
- Students will develop the abilities to apply the design process. (ITEA/STL 11)
  - Apply a design process to solve problems in and beyond the laboratory-classroom. (ITEA/STL 11H)
  - Test and evaluate the design in relation to pre-established requirements, such as criteria and constraints and refine as needed. (ITEA/STL 11K)

*Science: Benchmarks for Science Literacy (AAAS, 1993)*

- The Nature of Technology/Technology and Science (AAAS 3A)
  - Engineers, architects and others who engage in design and technology use scientific knowledge to solve practical problems, but they usually have to take human values and limitations into account as well. (AAAS 3A)
- The Physical Setting/The Earth (AAAS 4B)
  - The moon's orbit around the earth once in about 28 days changes what part of the moon is lighted by the sun and how much of that part can be seen from the earth—the phases of the moon. (AAAS 4B)

*Mathematics: Principles and Standards for School Mathematics (NCTM, 2000)*

- Representation
  - Use representations to model and interpret physical, social and mathematical phenomena.
- Measurement
  - Solve problems involving scale factors, using ratio and proportion.
  - Develop and use formulas to determine the circumference of circles and the area of triangles, parallelograms, trapezoids and circles and develop strategies to find the area of more complex shapes.
  - Understand relationships among units and convert from one unit to another within the same system.

### Learning Objectives

Students will:

1. Develop a design proposal for a lunar plant growth chamber.
2. Develop a production plan for a prototype lunar plant growth chamber.
3. Explain that management is the process of planning organizing and controlling work.
4. Describe how modeling, testing, evaluating and modifying are used to transform ideas into practical solutions.

5. Make two-dimensional and three-dimensional representations of the designed solution.
6. Apply the engineering design process to solve a problem.
7. Test and evaluate the design in relation to pre-established requirements, such as criteria and constraints, and refine as needed.

### Student Assessment Tools and/or Methods

1. Rubric for Brief Constructed Response Item

Why is it important to conduct a design review before beginning the construction of a product?

Category	Below Target	At Target	Above Target
<b>Understanding</b>	Response demonstrates an implied, partial or superficial understanding of the purpose of the system and how it operates.	Response demonstrates an understanding of the purpose of the system and what is required to operate it.	Response demonstrates an understanding of the complexities of the system and detailed requirements for operating it.
<b>Focus</b>	Lacks transitional information to show the relationship of the support to the question.	Addresses the demands of the question.	Exceeds the demands of the question.
<b>Use of Related Information</b>	Uses minimal information about requirements for the system.	Uses some expressed or implied information about requirements for the system.	Effectively uses expressed or implied information about requirements for the system.

## 2. Optional Rubric for Class Participation

*Teacher's Note:* Teachers may choose to use this rubric as a way to assess students, with or without making it a basis for student grades.

Category	Below Target	At Target	Above Target
<b>Preparation</b>	Rarely prepared. Minimal effort to participate.	Prepared for class. Attempts to answer teacher-generated questions.	Well prepared for class. Attempts to answer teacher-generated questions and adds additional information to class when relevant.
<b>Curiosity</b>	Rarely demonstrates curiosity.	Usually demonstrates curiosity.	Consistently demonstrates curiosity.
<b>Motivation for Learning</b>	Rarely demonstrates motivation for learning.	Usually demonstrates motivation for learning.	Consistently demonstrates motivation for learning.
<b>Use of Time</b>	Gives up easily; is not engaged. Has difficulty remaining on task.	Makes good use of class time to work on assignments and projects.	Makes excellent use of class time to work on assignments and projects.

## 3. Rubric for Oral Presentation

Category	Below Target	At Target	Above Target
<b>Organization</b>	Audience has difficulty following presentation because student jumps between topics.	Student presents information in logical sequence that audience can follow.	Student presents information in logical, interesting sequence that audience can follow.
<b>Subject Knowledge</b>	Student is uncomfortable with information and is able to answer only rudimentary questions.	Student is at ease with expected answers to all questions, but fails to elaborate.	Student demonstrates full knowledge (more than required) by answering all class questions with explanations and elaboration.
<b>Graphics</b>	Student occasionally uses graphics that rarely support text and presentation.	Student's graphics relate to text and presentation.	Student's graphics explain and reinforce text.
<b>Eye Contact</b>	Student occasionally uses eye contact, but still reads most of report.	Student maintains eye contact most of the time but frequently returns to notes.	Student maintains eye contact with audience, seldom returning to notes.
<b>Elocution</b>	Student's voice is low. Student incorrectly pronounces terms. Audience members have difficulty hearing presentation.	Student's voice is clear. Student pronounces most words correctly. Most audience members can hear presentation.	Student uses a clear voice and correct, precise pronunciation of terms so that all audience members can hear presentation.

## Resource Materials

### Print Materials

1. *Teachers and students investigating plants in space: A teacher's guide with activities for life sciences* (EG-1997-02-113-HQ). (1997). ASIN: B000H48XM6. Retrieved July 6, 2007 from <http://education.nasa.gov/edprograms/core/home/index.html>
2. *Fundamentals of space biology: research on cells, animals and plants in space* New York: Springer.
3. Pierce, A. & Karwatka, D. (1999). *Introduction to technology*. New York: Glencoe/McGraw-Hill, (pp. 157-180).

### Audiovisual Materials

1. *JFK moon speech at Rice University*. (1962, November 12). Retrieved from <http://www1.jsc.nasa.gov/er/seh/ricetalk.htm>

### Internet Sites

1. *Technical drawings of NASA spacecrafts*. (n.d.). Retrieved July 6, 2007 from <http://www.hq.nasa.gov/office/pao/History/diagrams/diagrams.htm>
2. *Educational plant growth hardware* (n.d.). Retrieved July 6, 2007 from <http://www.orbitec.com/outreach/index.htm> (Space Garden and BPSe)
3. *Space agriculture in the classroom* (n.d.). Retrieved July 6, 2007 from <http://www.spaceag.org/>
4. *Orthographic drawings* (n.d.). Retrieved March 1, 2007 from <http://www.cdli.ca/depted/g7/ortho.htm>
5. Ryan, V. (2002). *Frist angle: Orthographic projection*. Retrieved March 1, 2007 from <http://www.technologystudent.com/designpro/ortho1.htm>



## Lesson 3: Modified 5-E Lesson Plan

26

*Packing  
Up for the  
Moon*

*Lesson 3  
Developing  
and Sharing  
the Design*

### Engagement

1. Student design teams examine the material resources available for the construction of prototypes.
2. Students identify additional resources that may be needed to model parts of the design and create a plan for how they will acquire the resources.

### Exploration

1. The student design teams reexamine the selected approach and create detailed drawings that include the following:
  - a. Labels of important parts and systems
  - b. Stowed (stored) and deployed (not stored) configurations
  - c. Arrows that represent motion
  - d. Measurements such as length, width and height

### Explanation

1. The teacher explains that:
  - Modeling, testing, evaluating and modifying are used to transform ideas into practical solutions. Testing and evaluating are repeated after each modification.
  - Management is the process of planning organizing and controlling work. “Management is sometimes called getting work done through other people. Teamwork, responsibility and interpersonal dynamics play a significant role in the development and production of technological products.” (ITEA, 2000/2002)
  - Planning and reviewing a design before fabrication will improve the quality of a product by reducing the chance of omission or error in the design. Safety concerns may also be identified.
2. The teacher leads a discussion about what a design review should look like for the lunar plant growth chamber project.
3. The teacher discusses with the students why it is necessary to build scale models (save materials, cost, storage and work space).
4. The teacher describes what it means to build to scale.
5. The teacher demonstrates drawing techniques. (see *Sketching and Drawing*)
6. The teacher explains that a production plan should include the following:
  - Materials list including quantities and sizes
  - Tools and processes that will be needed to shape the parts
  - Assembly plan showing the order in which parts should be connected
  - Assignment of duties among design team members

**Extension**

1. Design teams present plans to other groups and make necessary adjustments.
2. Upon completion, the design team develops a visual representation of its detailed plans to share.
3. Students develop and analyze the presentation and present the solution to the class.
4. Students are given basil seeds to test their prototype.

**Evaluation**

1. Student knowledge, skills and attitudes are assessed using selected response items and rubrics for class participation, brief constructed responses and the oral presentation.
2. The rubrics are presented in advance of the activities to familiarize students with the expectations and performance criteria. They are also reviewed during the activities to guide students in the completion of assignments.
3. The teacher may wish to develop a collection of annotated exemplars of student work based on the rubrics. The exemplars serve as benchmarks for future assessments and may be used to familiarize students with the criteria for assessment.

## Lesson 3: Lesson Preparation

28

*Packing  
Up for the  
Moon*

*Lesson 3  
Developing  
and Sharing  
the Design*

### Teacher Planning

The laboratory-classroom should provide a flexible, resource-rich learning environment that includes areas for lectures and demonstrations, small group meetings and research activities. The teacher provides examples of available fabrication materials that the students can examine and with which they can experiment. Additional quantities of materials are made available upon completion of student fabrication plans.

### Tools/Materials/Equipment

- Chalkboard or overhead projector
- Teacher rubric included in lesson
- Cardboard, tag board and/or foam core
- Tape
- Scissors
- Graph paper (regular and isometric—see *Sketching and Drawing*)
- Rulers
- Construction paper
- Colored markers or pencils
- Glue

### Classroom Safety and Conduct

1. Students demonstrate respect and courtesy for the ideas expressed by others in the class.
2. Students show respect and appreciation for the efforts of others.
3. Students use tools and equipment in a safe manner and assume responsibility for their safety as well as for the safety of others.

## References

- American Association for the Advancement of Science (AAAS). (1993). *Benchmarks for science literacy*. New York: Oxford University Press: Author.
- Educational plant growth hardware* (Space Garden and BPSe). (n.d.). Retrieved July 6, 2007 from <http://www.orbitec.com/outreach/index.htm>
- Exploring the moon: A teacher's guide with activities* (pp. 17-18). (1997). Retrieved on July 6, 2007 from <http://ares.jsc.nasa.gov/Education/Activities/ExpMoon/MoonFactSheet.pdf>
- Fundamentals of space biology: research on cells, animals and plants in space* New York: Springer.
- International Technology Education Association (ITEA). (2005). *Planning learning: Developing technology curricula*. Reston, VA: Author.
- International Technology Education Association (ITEA). (2000/2002). *Standards for technological literacy: Content for the study of technology*. Reston, VA: Author.
- Into the cosmos*. (n.d.) Retrieved July 6, 2007 from <http://www.nasa.gov/multimedia/vidogallery/index.html>
- JFK moon speech at Rice University*. (1962, November 12). Retrieved from <http://www1.jsc.nasa.gov/er/seh/ricetalk.htm>
- NASA connect - functions and statistics - International Space Station - Up to us*. (n.d.). Retrieved July 6, 2007 from <http://www.open-video.org/details.php?videoid=6311>
- National Council of Teachers of Mathematics (NCTM). (2000). *Principles and standards for school mathematics*. Reston, VA: Author.
- Orthographic drawings* (n.d.). Retrieved March 1, 2007 from <http://www.cdli.ca/depted/g7/ortho.htm>
- Pierce, A. & Karwatka, D. (1999). *Introduction to technology*. New York: Glencoe/McGraw-Hill, (pp. 157-180).
- Ryan, V. (2002). *Frist angle: Orthographic projection*. Retrieved March 1, 2007 from <http://www.technologystudent.com/designpro/ortho1.htm>
- Space agriculture in the classroom* (n.d.). Retrieved July 6, 2007 from <http://www.spaceag.org/>
- Teachers and students investigating plants in ppace: A teacher's guide with activities for life sciences* (EG-1997-02-113-HQ). (1997). ASIN: B000H48XM6. Retrieved July 6, 2007 from <http://education.nasa.gov/edprograms/core/home/index.html>
- Technical drawings of NASA spacecrafts*. (n.d.). Retrieved July 6, 2007 from <http://www.hq.nasa.gov/office/pao/History/diagrams/diagrams.htm>
- The Constellation Program – Videos, images and descriptions of the new spacecraft systems*. (n.d.). Retrieved March 1, 2007 from [http://www.nasa.gov/mission\\_pages/constellation/main/index.html](http://www.nasa.gov/mission_pages/constellation/main/index.html)
- Wilson, J. (Ed.). (2007 February 23). *Camping on the moon will be a far out experience*. (n.d.). Retrieved July 6, 2007 from [http://www.nasa.gov/mission\\_pages/exploration/mmb/inflat-able-lunar-hab.html](http://www.nasa.gov/mission_pages/exploration/mmb/inflat-able-lunar-hab.html)

**Appendices  
Resource Documents**

## Moon ABCs Fact Sheet

Property	Earth	Moon	Brain Busters
Equatorial Diameter	12,756 km	3,476 km	How long would it take to drive around the Moon's equator at 80 km per hour?
Surface Area	510 million square km	37.8 million square km	The Moon's surface area is similar to that of one of Earth's continents. Which one?
Mass	$5.98 \times 10^{24}$ kg	$7.35 \times 10^{22}$ kg	What percentage of Earth's mass is the Moon's mass?
Volume	—	—	Can you calculate the volumes of Earth and the Moon?
Density	5.52 grams per cubic cm	3.34 grams per cubic cm	Check this by calculating the density from the mass and volume.
Surface Gravity	9.8 m/sec/sec	1.63 m/sec/sec	What fraction of Earth's gravity is the Moon's gravity?
Crust	Silicate rocks. Continents dominated by granites. Ocean crust dominated by basalt.	Silicate rocks. Highlands dominated by feldspar-rich rocks and maria by basalt.	What portion of each body is crust?
Mantle	Silicate rocks dominated by minerals containing iron and magnesium.	Similar to Earth.	Collect some silicate rocks and determine the density. Is the density greater or less than the Earth/Moon's density? Why?

Continued

## Moon ABCs Fact Sheet

Property	Earth	Moon	Brain Busters
Core	Iron, nickel metal	Same, but core is much smaller	What portion of each body is core?
Sediment or Regolith	Silicon and oxygen bound in minerals that contain water, plus organic materials.	Silicon and oxygen bound in minerals, glass produced by meteorite impacts, small amounts of gases (e.g., hydrogen) implanted by the solar wind. No water or organic materials.	Do you think life ever existed on the Moon? Why or why not?
Atmosphere (main constituents)	78% nitrogen, 21% oxygen	Basically none. Some carbon gases (CO <sup>2</sup> , CO, and methane), but very little of them. Pressure is about one-trillionth of Earth's atmospheric pressure.	Could you breathe the lunar atmosphere?
Length of Day (side-real rotation period)	23.93 hours	27.3 Earth days	How long does daylight last on the Moon?
Surface Temperature	Air temperature ranges from -88 °C (winter in polar regions) to 58 °C (summer in tropical regions).	Surface temperature ranges from -193 °C (night in polar regions) to 111 °C (day in equatorial regions).	Why are the temperatures of Earth and the Moon so different?
Surface Features	25% land (seven continents) with varied terrain of mountains, plains, river valleys. Ocean floor characterized by mountains, plains, and trenches.	84% heavily-cratered highlands. 16% basalt-covered maria. Impact craters—some with bright rays, crater chains, and rilles.	Compare maps of Earth and the Moon. Is there any evidence that plate tectonics operated on the Moon?

## Understanding the Role of Plants in a Lunar Base

Through the process of *photosynthesis*, plants remove carbon dioxide, or  $\text{CO}_2$ , from the air, while producing oxygen, or  $\text{O}_2$  and food, shown as a generic unit of carbohydrate below. This entire process is the reverse of respiration for humans, where food and  $\text{O}_2$  sustain metabolic needs. Plant systems can also be used to help purify wastewater. Water evaporates from the leaves and resultant humidity can be condensed as a source of clean water. This process is called *transpiration*.

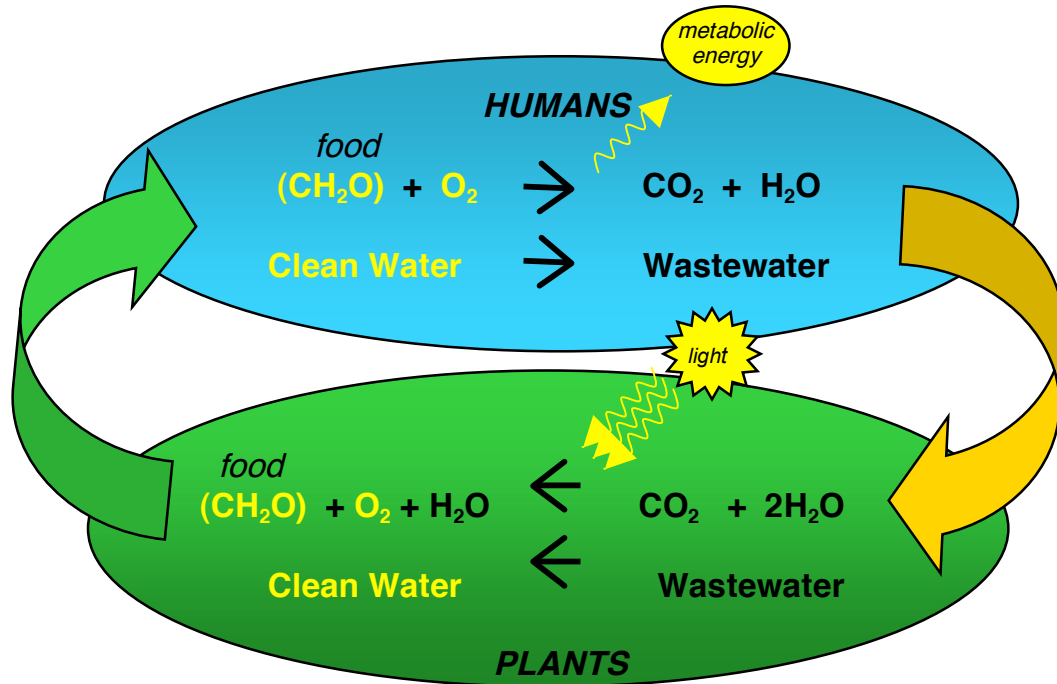

In space, plants will serve two main functions: oxygen production and food supply. A plant's ability to supply the oxygen needs for a person depends largely on the species of plant and the intensity and quality of light it receives.

At very high light intensities, wheat could supply much of one human's food and all their  $\text{O}_2$  needs from an area as small as 15 square meters.

At moderate light intensities, a diverse mix of crops could supply a more complete diet for one person from about 50 square meters and meet all of their  $\text{O}_2$  needs.



Use the information in *Understanding the Role of Plants in a Lunar Base* to complete the following:

1. Through photosynthesis, plants provide three important things to humans. They are \_\_\_\_\_, \_\_\_\_\_ and \_\_\_\_\_.
2. What happens during transpiration?
  - a. Water from the leaves is put into the atmosphere.
  - b. Water from the root flows to the stem.
  - c. Oxygen from the air is breathed by humans.
  - d. Wastewater is absorbed by roots.
3. What are the two main roles plants will serve in space?
4. What two factors affect a plant's ability to supply the oxygen needs for a person?
5. With high intensity lights, how much area would be needed for wheat to supply the food and oxygen needs for one person?
6. Explain why you think moderate lighting would require a larger growing area.

**Read and complete the following task.**

The teacher has drawn a square on the board that is one meter by one meter. This is an area of one squared meter. As a team, devise a plan for determining the following without the use of any measuring tools:

What portion of the classroom is taken up by 15 square meters?

Implement your plan and present your results in the form of a sketch of the classroom with the 15 square meters shaded in. Write a brief statement explaining how you arrived at your result.

**Identify Criteria for a Lunar Plant Growth Chamber.**

The first lunar bases will not likely be able to provide the large growing space needed to satisfy the food and oxygen needs of the astronauts. Instead, small plant growth chambers may be used to grow food for the purpose of supplementing the diet of the astronauts. Such a plant growth chamber would need to have systems that support plant life.

Make a list of criteria for such a plant growth chamber. Remember: Criteria are specific outcomes for a project. “What do you want it to do?” and “How well do you want it to be done?”

The Lunar Plant Growth Chamber must:

1. \_\_\_\_\_
2. \_\_\_\_\_
3. \_\_\_\_\_
4. \_\_\_\_\_
5. \_\_\_\_\_
6. \_\_\_\_\_

## **Understanding the Roles of Plants in a Lunar Base**

### Suggested Response Sheet

1. Remove carbon dioxide ( $\text{CO}_2$ ), produce oxygen ( $\text{O}_2$ ), and produce food.
2. a: Water from the leaves is put into the atmosphere.
3. Oxygen production and food supply.
4. The species of the plant and the intensity and quality of light it receives.
5. 15 square meters.
6. Answers will vary.

## KWL Chart

Requirements for a design include such factors as the desired elements and features of a product or system or the limits that are placed on the design. These are called **criteria** (what do we want?) and **constraints** (what are our limits?).

Technological designs typically have to meet requirements to be successful. These requirements usually relate to the purpose or function of the product or system. Other requirements, such as size and cost, describe the limits of the design. (ITEA, 2000/2002).

**Complete the following chart: Requirements for a plant growth chamber on the moon.**

What I Know	What I Would Like To Learn	What I Learned

## Design Brief: Track 1

NASA engineers have developed a plan for a lunar outpost. The station will be established near the lunar South Pole and be inhabited by two astronauts on a three-month mission. The available space on the lunar lander is extremely limited; therefore, all items must be designed to take up minimal space. The mission requires that a plant growth chamber be used to supplement the diet of the astronauts during their stay.

**Challenge:** Design and develop a plant growth chamber that will be used by astronauts to grow lettuce and tomatoes as dietary supplements on the moon.

### Requirements:

1. The lunar plant growth chamber must be able to provide a growing area of 10 square feet and have a delivery volume of three cubic feet or less.
2. The lunar plant growth chamber may expand to any volume desired.
3. The lunar plant growth chamber must be a separate, independent structure from the lunar station.
4. Placement and access to the chamber must make it possible for astronauts to tend to and harvest crops without venturing out onto the lunar surface.
5. The lunar plant growth chamber must have systems that provide light, temperature control, water and nutrient delivery and power.
6. The lunar plant growth chamber may link to the lunar station to get power.

### Procedure:

1. Students, working in groups of two to four, will use the engineering design process to develop a prototype of a lunar growth chamber.
2. Student groups will:
  - a. Assign a project manager.
  - b. Discuss the problem and take notes.
  - c. Individually sketch ideas and list possible solutions.
  - d. Select a few ideas and develop detailed drawings.
  - e. Evaluate each idea by identifying pros and cons.
  - f. Select an approach that meets the criteria and constraints.
  - g. Construct a prototype.
  - h. Evaluate and refine the prototype.
3. Make an oral presentation to the class describing the use and function of the lunar plant growth chamber. Students should use their model to demonstrate how it would work and point out important features.

### Materials for Prototype:

- Cardboard and/or foam core
- Tape
- Cool melt glue guns
- Plastic wrap
- Waxed paper
- Craft sticks or various size wood scraps
- Various hardware: nuts and bolts, screws, nails, paperclips
- Scissors
- Any other modeling materials deemed safe and appropriate by the teacher.

### Assessment:

Student work and participation will be assessed both during and after this activity.

### Rubric for Class Participation

Category	Below Target	At Target	Above Target
<b>Preparation</b>	Rarely prepared. Minimal effort to participate.	Prepared for class. Attempts to answer teacher-generated questions.	Well prepared for class. Attempts to answer teacher-generated questions and adds additional information to class when relevant.
<b>Curiosity</b>	Rarely demonstrates curiosity.	Usually demonstrates curiosity.	Consistently demonstrates curiosity.
<b>Motivation for Learning</b>	Rarely demonstrates motivation for learning.	Usually demonstrates motivation for learning.	Consistently demonstrates motivation for learning.
<b>Use of Time</b>	Gives up easily; is not engaged. Has difficulty remaining on task.	Makes good use of class time to work on assignments and projects.	Makes excellent use of class time to work on assignments and projects.

## Engineering Design Process

The engineering design process involves a series of steps that lead to the development of a new product or system. In this design challenge, students are to complete each step and document their work as they develop their lunar plant growth chamber. The students should be able to:

Identify the Problem – Students should state the challenge problem in their own words. Example: How can I design a \_\_\_\_\_ that will \_\_\_\_\_?

Identify Criteria and Constraints – Students should specify the design requirements (criteria). Example: Our growth chamber must have a growing surface of ten square feet and have a delivery volume of three cubic feet or less. Students should list the limits on the design due to available resources and the environment (constraints). Example: Our growth chamber must be accessible to astronauts without the need for leaving the spacecraft.

Brainstorm Possible Solutions – Each student in the group should sketch his or her own ideas as the group discusses ways to solve the problem. Labels and arrows should be included to identify parts and how they might move. These drawings should be quick and brief.

Generate Ideas – In this step, each student should develop two or three of his or her ideas more thoroughly. They should create new drawings that are orthographic projections (multiple views) and isometric drawings (three-dimensional depiction). These are to be drawn neatly using rulers to draw straight lines and to make parts proportional. Parts and measurements should be labeled clearly.

Explore Possibilities – The developed ideas should be shared and discussed among the team members. Students should record pros and cons of each design idea directly on the paper next to the drawings.

Select an Approach – Students should work in teams and identify the design that appears to solve the problem the best. Students should write a statement that describes why they chose the solution. This should include some reference to the criteria and constraints identified above.

Make a Model or Prototype – Students will construct a full-size or scale model based on their drawings. The teacher will help them identify and acquire appropriate modeling materials and tools. See the design brief for a sample list.

Refine the Design – Students will examine and evaluate their prototypes or designs based on the criteria and constraints. Groups may enlist students from other groups to review the solution and help identify changes that need to be made. Based on criteria and constraints, teams must identify any problems and proposed solutions.

## Lunar Plant Growth Chamber Design Steps: Track 1

**Group Members:** \_\_\_\_\_

**Product Name:** \_\_\_\_\_

Refer to the assessment rubric when completing each of these sections.

**Identify the problem:** \_\_\_\_\_

\_\_\_\_\_

**Criteria:** \_\_\_\_\_

\_\_\_\_\_

**Constraints:** \_\_\_\_\_

\_\_\_\_\_

**Brainstorm and Generate Ideas:** Each group member should list and sketch ideas on separate sheets of paper and attach to this form. Develop your best idea. Draw and label the parts.

**Explore Possibilities:** Make a pros and cons chart next to each of the best ideas and list advantages and disadvantages of the design.

**Select an approach. Explain your selection.** \_\_\_\_\_

\_\_\_\_\_

**Make a Model or Prototype:** Consult with your teacher about available resources and tools.

**How did you test and evaluate your solution?** \_\_\_\_\_

\_\_\_\_\_

\_\_\_\_\_

**Refine the design.** \_\_\_\_\_

\_\_\_\_\_

\_\_\_\_\_



## Lunar Plant Growth Chamber Design Steps

### Assessment Instrument – Engineering Design Process

Category	Below Target	At Target	Above Target
<b>Defining the Problem</b>	Rephrases the problem with limited clarity.	Rephrases the problem clearly.	Rephrases the problem clearly and precisely.
<b>Brainstorming a Solution (individual)</b>	Contributes few and/or implausible ideas or no ideas.	Contributes a plausible idea.	Contributes multiple, plausible ideas.
<b>Generating Ideas</b>	Contributes implausible ideas. Produces incomplete sketches. Does not present a concept.	Contributes one plausible idea. Produces marginally accurate pictorial and orthographic sketches of design concepts.	Contributes multiple plausible ideas. Produces accurate pictorial and orthographic sketches of design concepts.
<b>Identifying Criteria</b>	Does not restate the criteria clearly and fails to identify constraints.	Restates the criteria clearly and identifies several constraints.	Restates the criteria clearly and precisely and identifies many constraints.
<b>Exploring Possibilities</b>	Inadequately analyzes the pluses and minuses of a variety of possible solutions.	Satisfactorily analyzes the pluses and minuses of a variety of possible solutions.	Thoroughly analyzes the pluses and minuses of a variety of possible solutions.
<b>Selecting an Approach</b>	Selection of solution is not based on consideration of criteria and constraints.	Selects a promising solution based on criteria and constraints.	Selects a promising solution based on a thorough analysis criteria and constraints.
<b>Making a Model or Prototype</b>	Prototype meets the task criteria to a limited extent.	Prototype meets the task criteria.	Prototype meets the task criteria in insightful ways.
<b>Testing and Evaluating the Design</b>	Testing and evaluation processes are inadequate.	Testing and evaluation processes are adequate for refining the problem solution.	Testing and evaluation processes are innovative.
<b>Refining the Design</b>	Refinement based on testing and evaluation is not evident.	Refinements made based on testing and evaluation results.	Significant improvement in the design is made based on prototype testing and evaluation.

## Lunar Plant Growth Chamber Design Steps: Track 2

**Group Members:** \_\_\_\_\_

**Product Name:** \_\_\_\_\_

Refer to the assessment rubric when completing each of these sections.

**Identify the problem:** \_\_\_\_\_

\_\_\_\_\_

**Criteria:** \_\_\_\_\_

\_\_\_\_\_

**Constraints:** \_\_\_\_\_

\_\_\_\_\_

**Brainstorm and Generate Ideas:** Each group member should list and sketch ideas on separate sheets of paper and attach to this form. Develop your best idea. Draw and label the parts.

**Explore Possibilities:** Make a pros and cons chart next to each of the best ideas and list advantages and disadvantages of the design.

**Select an approach. Explain your selection.** \_\_\_\_\_

\_\_\_\_\_

**How did you test and evaluate your solution?** \_\_\_\_\_

\_\_\_\_\_

\_\_\_\_\_

**Refine the design.** \_\_\_\_\_

\_\_\_\_\_

\_\_\_\_\_

\_\_\_\_\_

## Lunar Plant Growth Chamber Design Steps

### Assessment Instrument – Engineering Design Process

Category	Below Target	At Target	Above Target
<b>Defining the Problem</b>	Rephrases the problem with limited clarity.	Rephrases the problem clearly.	Rephrases the problem clearly and precisely.
<b>Brainstorming a Solution (individual)</b>	Contributes few and/or implausible ideas or no ideas.	Contributes a plausible idea.	Contributes multiple, plausible ideas.
<b>Generating Ideas</b>	Contributes implausible ideas. Produces incomplete sketches. Does not present a concept.	Contributes one plausible idea. Produces marginally accurate pictorial and orthographic sketches of design concepts.	Contributes multiple plausible ideas. Produces accurate pictorial and orthographic sketches of design concepts.
<b>Identifying Criteria</b>	Does not restate the criteria clearly and fails to identify constraints.	Restates the criteria clearly and identifies several constraints.	Restates the criteria clearly and precisely and identifies many constraints.
<b>Exploring Possibilities</b>	Inadequately analyzes the pluses and minuses of a variety of possible solutions.	Satisfactorily analyzes the pluses and minuses of a variety of possible solutions.	Thoroughly analyzes the pluses and minuses of a variety of possible solutions.
<b>Selecting an Approach</b>	Selection of solution is not based on consideration of criteria and constraints.	Selects a promising solution based on criteria and constraints.	Selects a promising solution based on a thorough analysis criteria and constraints.

## Sketching and Drawing

Sketching is a quick way to record ideas about shape and relative sizes of parts in a design. It is an ideal way to record thoughts while brainstorming possible solutions. Sketches should include some labels and notes about possible sizes of parts. Sketching on graph paper is recommended.

Orthographic Projection is a way of drawing different views of the same object. Usually a front, side and plan view is drawn so that a person looking at the drawing can see all the important sides. These are useful when a design has been developed to a stage whereby it is almost ready to manufacture. One view cannot provide all of the information needed to describe the object.

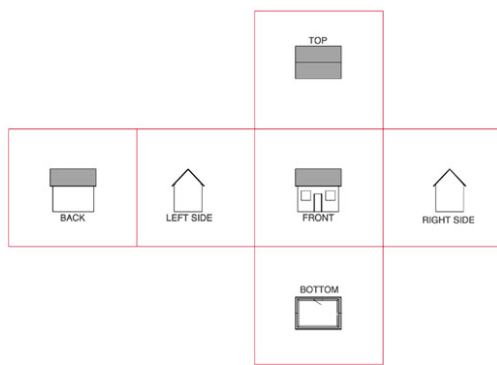

From [http://www2.arts.ubc.ca/TheatreDesign/crslib/draft\\_1/orthint.htm](http://www2.arts.ubc.ca/TheatreDesign/crslib/draft_1/orthint.htm)

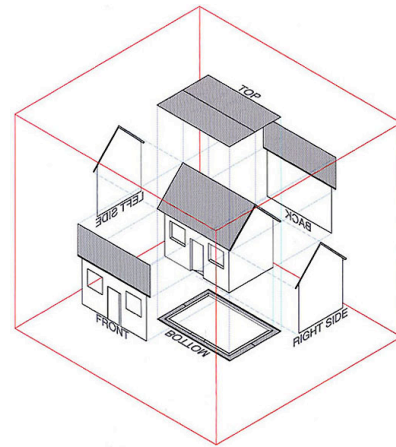

Isometric Drawing is a form of 3-D drawing in which there are three types of lines: vertical lines,  $30^\circ$  lines to the right and  $30^\circ$  lines to the left. Isometric graph paper makes it easy to draw neat, accurate images of design ideas. See the next page for a sample.

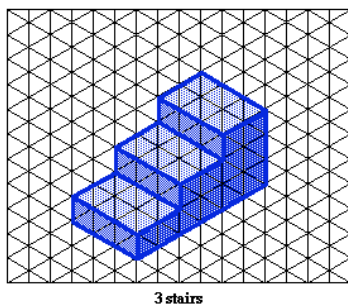

<http://mathforum.org/workshops/sum98/participants/sanders/IsomExamples.html>

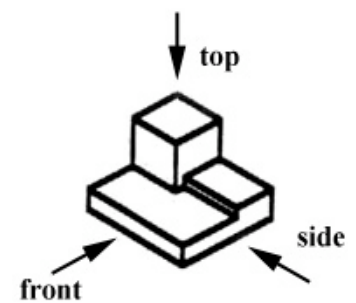
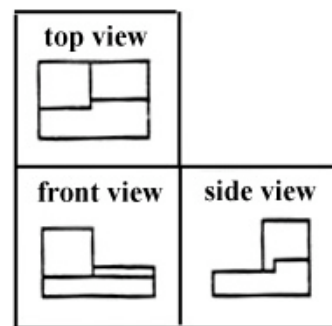

[http://pergatory.mit.edu/2.007/Resources/drawings/images/fig\\_02.jpg](http://pergatory.mit.edu/2.007/Resources/drawings/images/fig_02.jpg)

**Sketching and Drawing**  
**Isometric Graph Paper**

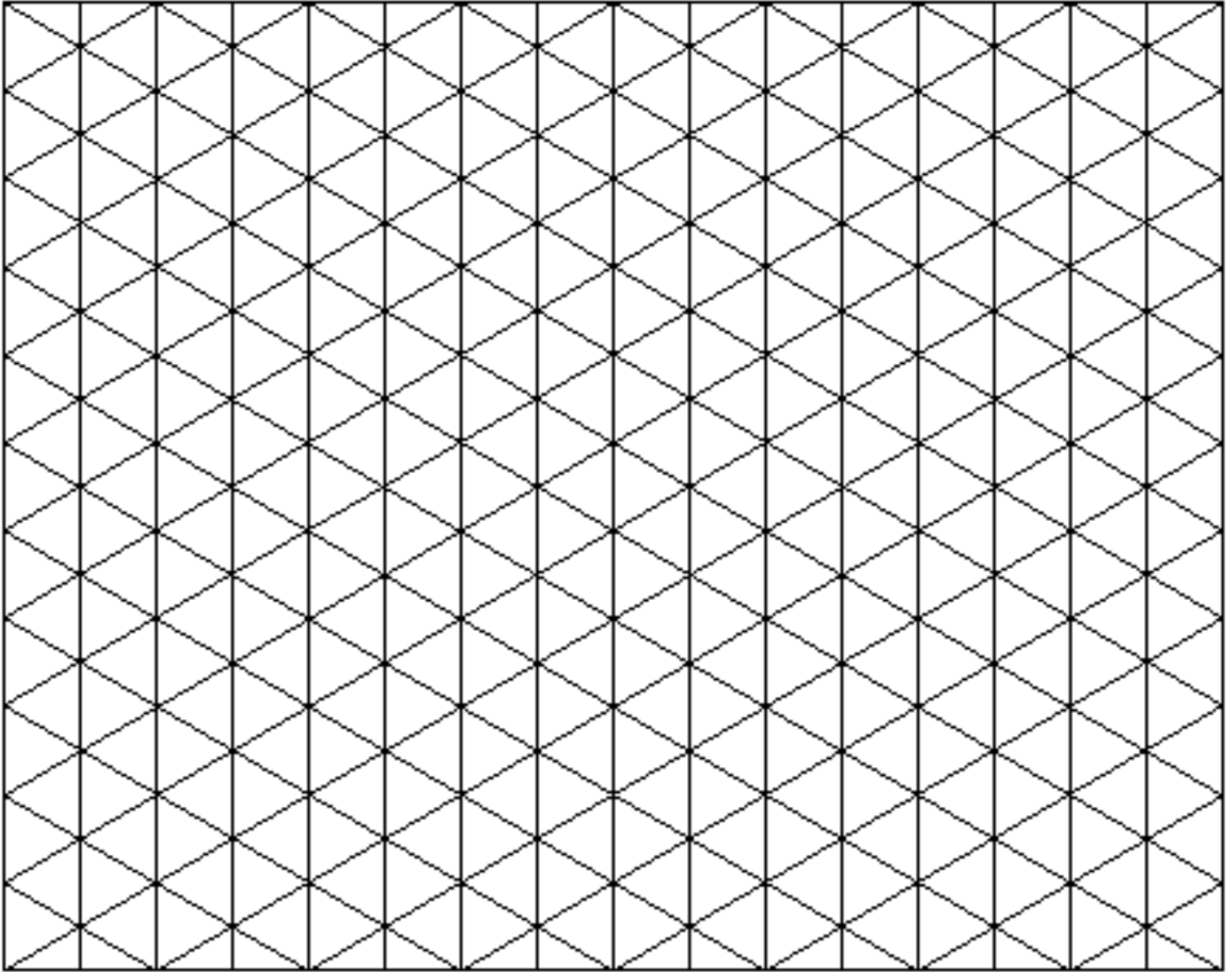

## Sketching and Drawing

These are some of the many diagrams that may be shown to students as examples of how information can be shared graphically.

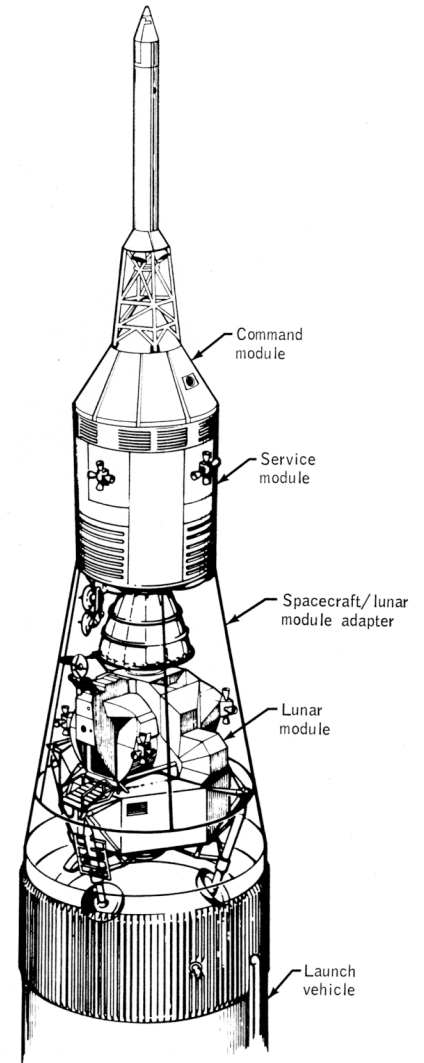
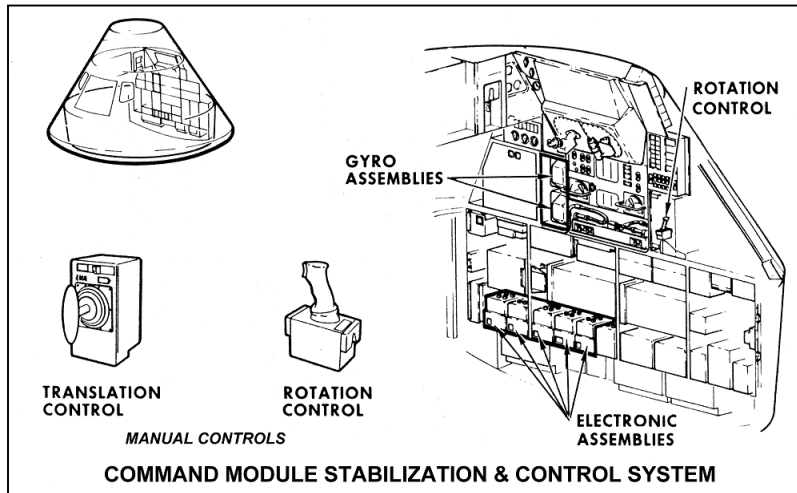

### APOLLO SPACECRAFT/LM ADAPTER

**PANEL SEPARATION BY EXPLOSIVE CHARGES (MDF)**

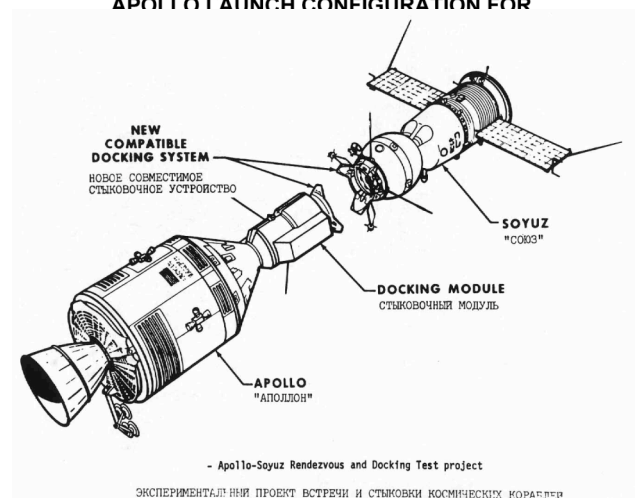
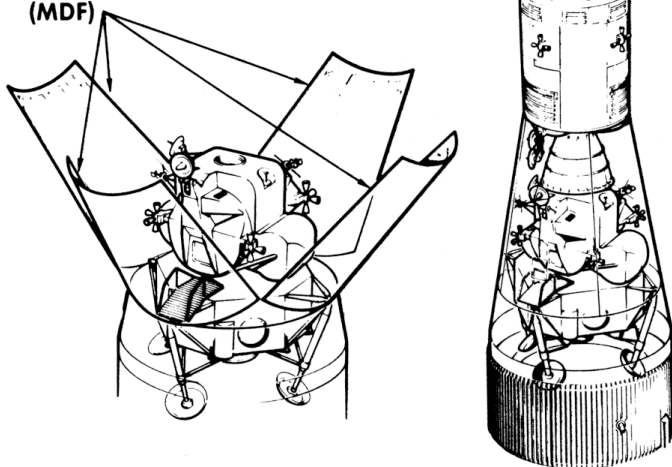

Teacher's Note: Source:  
<http://history.nasa.gov/diagrams/apollo.html>

## Modeling Ideas

The prototypes should show how the plant growth chamber deploys, or opens, once it is on the surface of the moon. They should also have pieces that represent the different systems needed to sustain plant life (light, water, etc.) and a method for astronauts to access the chamber.

Solid portions of the model can be made from cardboard and poster board. These materials work well because they are easy to cut and fold. A cardboard box can be cut at the corners so the sides can fold in or out.

Some solutions may involve a plastic bubble inflating to provide growing space. Wooden or wire supports may be inserted into the structure to hold the plastic in place. Explain to the students that they will not use the wire supports in the actual solution.

Plastic bottles may be used to represent storage units for water, pumps, carbon dioxide and lights.

Lights are likely to be in the form of banks of LEDs (light emitting diodes). Wooden or cardboard blocks may be dotted with small red and blue circles in order to model this.

Plants can also be modeled using colored paper. Lettuce can simply be depicted by a crumbled piece of green paper, while tomato plants can be a stick with green leaves attached.

# Standards for Technological Literacy Program Responsibility Matrix

## KEY

4 = Benchmark must be covered in detail, lessons and assessments cover this content  
 3 = Benchmark is covered, but topics and lessons do not center on them  
 2 = Topics and lessons refer to previous knowledge and integrate content covered  
 1 = Topics and lessons refer to previous knowledge

### Course Total

	172	232	212	147	166	202	154	97	182	236	209	187
	K-2	3-5	Exploring Technology	Invention & Innovation	Systems	Foundations	Impacts	Issues	Technological Design	Advanced Design Applications	Advanced Technological Applications	Engineering Design

## The Nature of Technology

STL-1 Understanding the characteristics and scope of technology		8	12	12	16	7	10	8	12	10	9	10	11
<b>A</b>	The natural world and human-made world are different.	4											
<b>B</b>	All people use tools and techniques to help them do things.	4											
<b>C</b>	Things that are found in nature differ from things that are human-made in how they are produced and used.		4										
<b>D</b>	Tools, materials, and skills are used to make things and carry out tasks.		4										
<b>E</b>	Creative thinking and economic and cultural influences shape technological development.		4										
<b>F</b>	New products and systems can be developed to solve problems or to help do things that could not be done without the help of technology.			4	4	4							
<b>G</b>	The development of technology is a human activity and is the result of individual or collective needs and the ability to be creative.			3	4								
<b>H</b>	Technology is closely linked to creativity, which has resulted in innovation.			3	4								
<b>I</b>	Corporations can often create demand for a product by bringing it onto the market and advertising it.			2	4	3							
<b>J</b>	The nature and development of technological knowledge and processes are functions of the setting.						4	2	2	4	3	4	4
<b>K</b>	The rate of technological development and diffusion is increasing rapidly.						2	4	3				
<b>L</b>	Inventions and innovations are the results of specific, goal-oriented research.						2	2	3	3	4	4	4
<b>M</b>	Most development of technologies these days is driven by the profit motive and the market.						2		4	3	2	2	3



# Standards for Technological Literacy Program Responsibility Matrix

## KEY

4 = Benchmark must be covered in detail, lessons and assessments cover this content  
 3 = Benchmark is covered, but topics and lessons do not center on them  
 2 = Topics and lessons refer to previous knowledge and integrate content covered  
 1 = Topics and lessons refer to previous knowledge

### Course Total

	172	232	212	147	166	202	154	97	182	236	209	187
	K-2	3-5	Exploring Technology	Invention & Innovation	Systems	Foundations	Impacts	Issues	Technological Design	Advanced Design Applications	Advanced Technological Applications	Engineering Design

## The Nature of Technology

	20	28	21	10	33	114	0	0	33	33	33	36
<b>STL-2 Understanding the core concepts of technology</b>	<b>20</b>	<b>28</b>	<b>21</b>	<b>10</b>	<b>33</b>	<b>114</b>	<b>0</b>	<b>0</b>	<b>33</b>	<b>33</b>	<b>33</b>	<b>36</b>
A Some systems are found in nature, and some are made by humans.	4											
B Systems have parts or components that work together to accomplish a goal.	4											
C Tools are simple objects that help humans complete tasks.	4											
D Different materials are used in making things.	4											
E People plan in order to get things done.	4											
F A subsystem is a system that operates as a part of another system.		4										
G When parts of a system are missing, it may not work as planned.		4										
H Resources are the things needed to get a job done, such as tools and machines, materials, information, energy, people, capital, and time.		4										
I Tools are used to design, make, use, and assess technology.		4										
J Materials have many different properties.		4										
K Tools and machines extend human capabilities, such as holding, lifting, carrying, fastening, separating, and computing.		4										
L Materials have many different properties.		4										
M Technological systems include input, processes, output, and, at times, feedback.			4		3							
N Systems thinking involves considering how every part relates to others			4		3							
O An open-loop system has no feedback path and requires human intervention, while a closed-loop system uses feedback.					4							
P Technological systems can be connected to one another.			3		4							
Q Malfunctions of any part of a system may affect the function and quality of the system.				3	4							
R Requirements are the parameters placed on the development of a product or system.				3	4							
S Trade-off is a decision process recognizing the need for careful compromises among competing factors.				4								
T Trade-off is a decision process recognizing the need for careful compromises among competing factors.			4		3							
U Different technologies involve different sets of processes.			3		4							

## Standards for Technological Literacy Program Responsibility Matrix

### KEY

4 = Benchmark must be covered in detail, lessons and assessments cover this content  
 3 = Benchmark is covered, but topics and lessons do not center on them  
 2 = Topics and lessons refer to previous knowledge and integrate content covered  
 1 = Topics and lessons refer to previous knowledge

		Course Total	172	232	212	147	166	202	154	97	182	236	209	187
		K-2	3-5	Exploring Technology	Invention & Innovation	Systems	Foundations	Impacts	Issues	Technological Design	Advanced Design Applications	Advanced Technological Applications	Engineering Design	
<b>STL-2 Understanding the core concepts of technology (continued)</b>		<b>20</b>	<b>28</b>	<b>21</b>	<b>10</b>	<b>33</b>	<b>14</b>	<b>0</b>	<b>0</b>	<b>33</b>	<b>33</b>	<b>33</b>	<b>36</b>	
<b>V</b>	Controls are mechanisms or particular steps that people perform using information about the system that causes systems to change.			3		4								
<b>W</b>	Systems thinking applies logic and creativity with appropriate compromises in complex real-life problems.									4	4	4	4	
<b>X</b>	Systems, which are the building blocks of technology, are embedded within larger technological, social, and environmental systems.						4				3	4		
<b>Y</b>	The stability of a technological system is influenced by all of the components in the system, especially those in the feedback loop.						3			4	4	3	4	
<b>Z</b>	Selecting resources involves trade-offs between competing values, such as availability, cost, desirability, and waste.						3			4	2	2	4	
<b>AA</b>	Requirements involve the identification of the criteria and constraints of a product or system and the determination of how they affect the final design and development.									4	4	4	4	
<b>BB</b>	Optimization is an ongoing process or methodology of designing or making a product and is dependent on criteria and constraints.									3	4	3	4	
<b>CC</b>	New technologies create new processes.						4			4	3	4	4	
<b>DD</b>	Quality control is a planned process to ensure that a product, service, or system meets established criteria.									3	3	2	4	
<b>EE</b>	Management is the process of planning, organizing, and controlling work.									3	2	3	4	
<b>FF</b>	Complex systems have many layers of controls and feedback loops to provide information.									4	4	4	4	

# Standards for Technological Literacy Program Responsibility Matrix

## KEY

4 = Benchmark must be covered in detail, lessons and assessments cover this content  
 3 = Benchmark is covered, but topics and lessons do not center on them  
 2 = Topics and lessons refer to previous knowledge and integrate content covered  
 1 = Topics and lessons refer to previous knowledge

### Course Total

		172	232	212	147	166	202	154	97	182	236	209	187
		K-2	3-5	Exploring Technology	Invention & Innovation	Systems	Foundations	Impacts	Issues	Technological Design	Advanced Design Applications	Advanced Technological Applications	Engineering Design
<b>STL-3 Understanding the relationships among technologies and connections with other fields of study</b>		4	8	6	5	12	11	5	7	12	10	10	12
<b>A</b>	The study of technology uses many of the same ideas and skills as other subjects.	4											
<b>B</b>	Technologies are often combined.		4										
<b>C</b>	Various relationships exist between technology and other fields of study.		4										
<b>D</b>	Technological systems often interact with one another.			3	2	4							
<b>E</b>	A product, system, or environment developed for one setting may be applied to another setting.				3	4							
<b>F</b>	Knowledge gained from other fields of study has a direct effect on the development of technological products and systems.			3		4							
<b>G</b>	Technology transfer occurs when a new user applies an existing innovation developed for one purpose in a different function.						3	2		4	4	3	4
<b>H</b>	Technological innovation often results when ideas, knowledge, or skills are shared within a technology, among						3			4	3	4	4
<b>I</b>	Technological ideas are sometimes protected through the process of patenting.						2		3	4			4
<b>J</b>	Technological progress promotes the advancement of science and mathematics.						3	3	4		3	3	
<b>Technology and Society</b>													
<b>STL-4 Understanding the cultural, social, economic and political effects of technology</b>		4	8	14	11	3	2	13	10	6	7	8	4
<b>A</b>	The use of tools and machines can be helpful or harmful.	4											
<b>B</b>	When using technology, results can be good or bad.		4										
<b>C</b>	The use of technology can have unintended consequences.		4										
<b>D</b>	The use of technology affects humans in various ways, including their safety, comfort, choices, and attitudes about technology's development and use.			4									
<b>E</b>	Technology, by itself, is neither good nor bad, but decisions about the use of products and systems can result in desirable or undesirable consequences.			4	3	3							
<b>F</b>	The development and use of technology poses ethical issues.			3	4								
<b>G</b>	Economic, political, and cultural issues are influenced by the development and use of technology.			3	4								
<b>H</b>	Changes caused by the use of technology can range from gradual to rapid and from subtle to obvious.							4		2	3	4	
<b>I</b>	Making decisions about the use of technology involves weighing the trade-offs between the positive and negative effects.						2	3	4				
<b>J</b>	Ethical considerations are important in the development, selection, and use of technologies.							3	2	4	4	4	4
<b>I</b>	The transfer of a technology from one society to another can cause cultural, social, economic, and political changes affecting both societies to varying degrees.							3	4				

# Standards for Technological Literacy Program Responsibility Matrix

## KEY

4 = Benchmark must be covered in detail, lessons and assessments cover this content  
 3 = Benchmark is covered, but topics and lessons do not center on them  
 2 = Topics and lessons refer to previous knowledge and integrate content covered  
 1 = Topics and lessons refer to previous knowledge

### Course Total

		172	232	212	147	166	202	154	97	182	236	209	187
		K-2	3-5	Exploring Technology	Invention & Innovation	Systems	Foundations	Impacts	Issues	Technological Design	Advanced Design Applications	Advanced Technological Applications	Engineering Design
<b>STL-5 Understanding the effects of technology on the environment</b>		4	8	8	6	9	3	18	6	11	13	13	11
<b>A</b>	Some materials can be reused and/or recycled.	4											
<b>B</b>	Waste must be appropriately recycled or disposed of to prevent unnecessary harm to the environment.		4										
<b>C</b>	The use of technology affects the environment in good and bad ways.		4										
<b>D</b>	The management of waste produced by technological systems is an important societal issue.			4		3							
<b>E</b>	Technologies can be used to repair damage caused by natural disasters and to break down waste from the use of various products and systems.				3	4							
<b>F</b>	Decisions to develop and use technologies often put environmental and economic concerns in direct competition with one another.			4	3	2							
<b>G</b>	Humans can devise technologies to conserve water, soil, and energy through such techniques as reusing, reducing and recycling.								4	3	2	2	3
<b>H</b>	When new technologies are developed to reduce the use of resources, considerations of trade-offs are important.							3		4	2	3	4
<b>I</b>	With the aid of technology, various aspects of the environment can be monitored to provide information for decisionmaking.							4			2		
<b>J</b>	The alignment of technological processes with natural processes maximizes performance and reduces negative impacts on the environment.							4				2	
<b>K</b>	Humans devise technologies to reduce the negative consequences of other technologies. 3 4 3 3 4							3		4	3	3	4
<b>L</b>	Decisions regarding the implementation of technologies involve the weighing of trade-offs between predicted positive and negative effects on the environment.						3	4	2		4	3	
<b>STL-6 Understanding the role of society in the development and use of technology</b>		4	8	13	12	2	4	10	2	4	3	3	4
<b>A</b>	Products are made to meet individual needs and wants.	4											
<b>B</b>	Because people's needs and wants change, new technologies are developed, and old ones are improved to meet those changes.		4										
<b>C</b>	Individual, family, community, and economic concerns may expand or limit the development of technologies.		4										
<b>D</b>	Throughout history, new technologies have resulted from the demands, values, and interests of individuals, businesses, industries, and societies.			4									
<b>E</b>	The use of inventions and innovations has led to changes in society and the creation of new needs and wants.			3	4								
<b>F</b>	Social and cultural priorities and values are reflected in technological devices.			3	4								
<b>G</b>	Meeting societal expectations is the driving force behind the acceptance and use of products and systems.			3	4	2							
<b>H</b>	Different cultures develop their own technologies to satisfy their individual and shared needs, wants, and values.							4					
<b>I</b>	The decision whether to develop a technology is influenced by societal opinions and demands, in addition to corporate cultures.							3	2	4			4
<b>J</b>	A number of different factors, such as advertising, the strength of the economy, the goals of a company, and the latest fads contribute to shaping the design of and demand for various technologies.						4	3			3	3	

## Standards for Technological Literacy Program Responsibility Matrix

### KEY

4 = Benchmark must be covered in detail, lessons and assessments cover this content  
 3 = Benchmark is covered, but topics and lessons do not center on them  
 2 = Topics and lessons refer to previous knowledge and integrate content covered  
 1 = Topics and lessons refer to previous knowledge

### Course Total

	172	232	212	147	166	202	154	97	182	236	209	187
	K-2	3-5	Exploring Technology	Invention & Innovation	Systems	Foundations	Impacts	Issues	Technological Design	Advanced Design Applications	Advanced Technological Applications	Engineering Design

### The Nature of Technology

#### STL-7 Understanding the influence of technology on history

		4	4	6	12	4	28	22	9	0	3	3	0
A	The way people live and work has changed throughout history because of technology.	4											
B	People have made tools to provide food, to make clothing, and to protect themselves.		4										
C	Many inventions and innovations have evolved by using slow and methodical processes of tests and refinements.			3	4								
D	The specialization of function has been at the heart of many technological improvements.			3	4								
E	The design and construction of structures for service or convenience have evolved from the development of techniques for measurement, controlling systems, and the understanding of spatial relationships.					4							
F	In the past, an invention or innovation was not usually developed with the knowledge of science.				4								
G	Most technological development has been evolutionary, the result of a series of refinements to a basic invention..							4					
H	The evolution of civilization has been directly affected by, and has in turn affected, the development and use of tools and materials.								3	4			
I	Throughout history, technology has been a powerful force in reshaping the social, cultural, political, and economic landscape.								4	3			
J	Early in the history of technology, the development of many tools and machines was based not on scientific knowledge but on technological know-how.							4					
K	The Iron Age was defined by the use of iron and steel as the primary materials for tools.							4	3				
L	The Middle Ages saw the development of many technological devices that produced long-lasting effects on technology and society							4	3				
M	The Renaissance, a time of rebirth of the arts and humanities, was also an important development in the history of technology.							4	3				
N	The Industrial Revolution saw the development of continuous manufacturing, sophisticated transportation and communication systems, advanced construction practices, and improved education and leisure time.							4	3				
O	The Information Age places emphasis on the processing and exchange of information.							4	3	2		3	3

## Standards for Technological Literacy Program Responsibility Matrix

### KEY

4 = Benchmark must be covered in detail, lessons and assessments cover this content  
 3 = Benchmark is covered, but topics and lessons do not center on them  
 2 = Topics and lessons refer to previous knowledge and integrate content covered  
 1 = Topics and lessons refer to previous knowledge

### Course Total

	172	232	212	147	166	202	154	97	182	236	209	187
	K-2	3-5	Exploring Technology	Invention & Innovation	Systems	Foundations	Impacts	Issues	Technological Design	Advanced Design Applications	Advanced Technological Applications	Engineering Design

### Design

STL-8 Understanding the attributes of design	8	8	11	10	3	13	2	0	15	16	15	15
<b>A</b> Everyone can design solutions to a problem.	4											
<b>B</b> Design is a creative process.	4											
<b>C</b> The design process is a purposeful method of planning practical solutions to problems.		4										
<b>D</b> Requirements for a design include such factors as the desired elements and features of a product or system or the limits that are placed on the design.		4										
<b>E</b> Design is a creative planning process that leads to useful products and systems.			3	4	3							
<b>F</b> There is no perfect design.			4	3								
<b>G</b> Requirements for a design are made up of criteria and constraints.			4	3								
<b>H</b> The design process includes defining a problem, brainstorming, researching and generating ideas, identifying criteria and specifying constraints, exploring possibilities, selecting an approach, developing a design proposal, making a model or prototype.						4			3	4	4	3
<b>I</b> Design problems are seldom presented in a clearly defined form.						3			4	4	3	4
<b>J</b> The design needs to be continually checked and critiqued, and the ideas of the design must be redefined and improved.						3			4	4	4	4
<b>K</b> Requirements of a design, such as criteria, constraints, and efficiency, sometimes compete with each other.						3	2		4	4	4	4

## Standards for Technological Literacy Program Responsibility Matrix

### KEY

4 = Benchmark must be covered in detail, lessons and assessments cover this content  
 3 = Benchmark is covered, but topics and lessons do not center on them  
 2 = Topics and lessons refer to previous knowledge and integrate content covered  
 1 = Topics and lessons refer to previous knowledge

		Course Total	172	232	212	147	166	202	154	97	182	236	209	187
		K-2	3-5	Exploring Technology	Invention & Innovation	Systems	Foundations	Impacts	Issues	Technological Design	Advanced Design Applications	Advanced Technological Applications	Engineering Design	
STL-9 Understanding engineering design		8	12	11	10	0	13	2	0	14	10	10	15	
<b>A</b>	The engineering design process includes identifying a problem, looking for ideas, developing solutions, and sharing solutions with others.	4												
<b>B</b>	Expressing ideas to others verbally and through sketches and models is an important part of the design process.	4												
<b>C</b>	The engineering design process involves defining a problem, generating ideas, selecting a solution, testing the solution(s), making the item, evaluating it, and presenting the results.		4											
<b>D</b>	When designing an object, it is important to be creative and consider all ideas.		4											
<b>E</b>	Models are used to communicate and test design ideas and processes.		4											
<b>F</b>	Design involves a set of steps, which can be performed in different sequences and repeated as needed.			4	3									
<b>G</b>	Brainstorming is a group problem-solving design process in which each person in the group presents his or her ideas in an open forum.			3	4									
<b>H</b>	Modeling, testing, evaluating, and modifying are used to transform ideas into practical solutions.			4	3									
<b>I</b>	Established design principles are used to evaluate existing designs, to collect data, and to guide the design process.						4			3	4	3	3	
<b>J</b>	Engineering design is influenced by personal characteristics, such as creativity, resourcefulness, and the ability to visualize and think abstractly.						3			4	3	3	4	
<b>K</b>	A prototype is a working model used to test a design concept by making actual observations and necessary adjustments.						3			4	3	4	4	
<b>L</b>	The process of engineering design takes into account a number of factors.						3	2		3			4	

## Standards for Technological Literacy Program Responsibility Matrix

### KEY

4 = Benchmark must be covered in detail, lessons and assessments cover this content  
 3 = Benchmark is covered, but topics and lessons do not center on them  
 2 = Topics and lessons refer to previous knowledge and integrate content covered  
 1 = Topics and lessons refer to previous knowledge

### Course Total

		172	232	212	147	166	202	154	97	182	236	209	187
		K-2	3-5	Exploring Technology	Invention & Innovation	Systems	Foundations	Impacts	Issues	Technological Design	Advanced Design Applications	Advanced Technological Applications	Engineering Design
<b>STL-10 Understanding the role of troubleshooting, R&amp;D, etc. in problem-solving</b>		8	12	9	10	6	4	7	11	3	14	14	3
<b>A</b>	Asking questions and making observations helps a person to figure out how things work. .	4											
<b>B</b>	All products and systems are subject to failure. Many products and systems, however, can be fixed.	4											
<b>C</b>	Troubleshooting is a way of finding out why something does not work so that it can be fixed.		4										
<b>D</b>	Invention and innovation are creative ways to turn ideas into real things.		4										
<b>E</b>	The process of experimentation, which is common in science, can also be used to solve technological problems.		4										
<b>F</b>	Troubleshooting is a problem-solving method used to identify the cause of a malfunction in a technological system.			3	2	4							
<b>G</b>	Invention is a process of turning ideas and imagination into devices and systems. Innovation is the process of modifying an existing product or system to improve it.			3	4	2							
<b>H</b>	Some technological problems are best solved through experimentation.			3	4								
<b>I</b>	Research and development is a specific problem-solving approach that is used intensively in business and industry to prepare devices and systems for the marketplace.						4			3	3	3	3
<b>J</b>	Technological problems must be researched before they can be solved.							4	3		4	4	
<b>K</b>	Not all problems are technological, and not every problem can be solved using technology.								4		4	3	
<b>L</b>	Many technological problems require a multidisciplinary approach.							3	4		3	4	



# Standards for Technological Literacy Program Responsibility Matrix

## KEY

4 = Benchmark must be covered in detail, lessons and assessments cover this content  
 3 = Benchmark is covered, but topics and lessons do not center on them  
 2 = Topics and lessons refer to previous knowledge and integrate content covered  
 1 = Topics and lessons refer to previous knowledge

Course Total	172	232	212	147	166	202	154	97	182	236	209	187
	K-2	3-5	Exploring Technology	Invention & Innovation	Systems	Foundations	Impacts	Issues	Technological Design	Advanced Design Applications	Advanced Technological Applications	Engineering Design

### Abilities for a Technological World

STL-11 Abilities to apply the design process		12	16	10	19	3	18	3	4	16	18	18	17
<b>A</b>	Brainstorm people's needs and wants and pick some problems that can be solved through the design process.	4											
<b>B</b>	Build or construct an object using the design process.	4											
<b>C</b>	Investigate how things are made and how they can be improved.	4											
<b>D</b>	Identify and collect information about everyday problems that can be solved by technology, and generate ideas and requirements for solving a problem.		4										
<b>E</b>	The process of designing involves presenting some possible solutions in visual form and then selecting the best solution(s) from many.		4										
<b>F</b>	Test and evaluate the solutions for the design problem.		4										
<b>G</b>	Improve the design solutions.		4										
<b>H</b>	Apply a design process to solve problems in and beyond the laboratory-classroom.			3	4								
<b>I</b>	Specify criteria and constraints for the design.			3	4								
<b>J</b>	Make two-dimensional and three-dimensional representations of the designed solution.				4								
<b>K</b>	Test and evaluate the design in relation to pre-established requirements, such as criteria and constraints, and refine as needed.				4								
<b>L</b>	Make a product or system and document the solution.			4	3	3							
<b>M</b>	Identify the design problem to solve and decide whether or not to address it.							3	4				
<b>N</b>	Identify criteria and constraints and determine how these will affect the design process.						4			3	4	3	3
<b>O</b>	Refine a design by using prototypes and modeling to ensure quality, efficiency, and productivity of the final product.						4			3	4	4	3
<b>P</b>	Evaluate the design solution using conceptual, physical, and mathematical models at various intervals of the design						3			3	3	4	4
<b>Q</b>	Develop and produce a product or system using a design process.						3			4	4	4	4
<b>R</b>	Evaluate final solutions and communicate observation, processes, and results of the entire design process, using verbal, graphic, quantitative, virtual, and written means, in addition to three-dimensional models.						4			3	3	3	3

## Standards for Technological Literacy Program Responsibility Matrix

### KEY

4 = Benchmark must be covered in detail, lessons and assessments cover this content  
 3 = Benchmark is covered, but topics and lessons do not center on them  
 2 = Topics and lessons refer to previous knowledge and integrate content covered  
 1 = Topics and lessons refer to previous knowledge

### Course Total

		172	232	212	147	166	202	154	97	182	236	209	187
		K-2	3-5	Exploring Technology	Invention & Innovation	Systems	Foundations	Impacts	Issues	Technological Design	Advanced Design Applications	Advanced Technological Applications	Engineering Design
<b>STL-12 Abilities to use and maintain technological products and systems</b>		<b>12</b>	<b>16</b>	<b>8</b>	<b>3</b>	<b>13</b>	<b>20</b>	<b>0</b>	<b>0</b>	<b>0</b>	<b>11</b>	<b>11</b>	<b>0</b>
<b>A</b>	Discover how things work.	4											
<b>B</b>	Use hand tools correctly and safely and be able to name them correctly.	4											
<b>C</b>	Recognize and use everyday symbols.	4											
<b>D</b>	Follow step-by-step directions to assemble a product.		4										
<b>E</b>	Select and safely use tools, products, and systems for specific tasks.		4										
<b>F</b>	Use computers to access and organize information.		4										
<b>G</b>	Use common symbols, such as numbers and words, to communicate key ideas.		4										
<b>H</b>	Use information provided in manuals, protocols, or by experienced people to see and understand how things work.			4		3							
<b>I</b>	Use tools, materials, and machines safely to diagnose, adjust, and repair systems.					4							
<b>J</b>	Use computers and calculators in various applications.			4	3	2							
<b>K</b>	Operate and maintain systems in order to achieve a given purpose.					4							
<b>L</b>	Document processes and procedures and communicate them to different audiences using appropriate oral and written techniques.						4				3	3	
<b>M</b>	Diagnose a system that is malfunctioning and use tools, materials, machines, and knowledge to repair it.						4				4	4	
<b>N</b>	Troubleshoot, analyze, and maintain systems to ensure safe and proper function and precision.						4						
<b>O</b>	Operate systems so that they function in the way they were designed.						4						
<b>P</b>	Use computers and calculators to access, retrieve, organize, process, maintain, interpret, and evaluate data and information in order to communicate.						4				4	4	

## Standards for Technological Literacy Program Responsibility Matrix

### KEY

4 = Benchmark must be covered in detail, lessons and assessments cover this content  
 3 = Benchmark is covered, but topics and lessons do not center on them  
 2 = Topics and lessons refer to previous knowledge and integrate content covered  
 1 = Topics and lessons refer to previous knowledge

### Course Total

		172	232	212	147	166	202	154	97	182	236	209	187
		K-2	3-5	Exploring Technology	Invention & Innovation	Systems	Foundations	Impacts	Issues	Technological Design	Advanced Design Applications	Advanced Technological Applications	Engineering Design
<b>STL-13 Abilities to assess the impact of products and systems</b>		<b>8</b>	<b>12</b>	<b>9</b>	<b>3</b>	<b>16</b>	<b>4</b>	<b>15</b>	<b>11</b>	<b>1</b>	<b>9</b>	<b>9</b>	<b>1</b>
<b>A</b>	Collect information about everyday products and systems by asking questions.	4											
<b>B</b>	Determine if the human use of a product or system creates positive or negative results.	4											
<b>C</b>	Compare, contrast, and classify collected information in order to identify patterns.		4										
<b>D</b>	Investigate and assess the influence of a specific technology on the individual, family, community, and environment.		4										
<b>E</b>	Examine the trade-offs of using a product or system and decide when it could be used.		4										
<b>F</b>	Design and use instruments to gather data.			3		4							
<b>G</b>	Use data collected to analyze and interpret trends in order to identify the positive or negative effects of a technology.				3								
<b>H</b>	Identify trends and monitor potential consequences of technological development.			3		4							
<b>I</b>	Interpret and evaluate the accuracy of the information obtained and determine if it is useful.			3		4							
<b>J</b>	Collect information and evaluate its quality.						4	3	2	1	2	2	1
<b>K</b>	Synthesize data, analyze trends, and draw conclusions regarding the effect of technology on the individual, society, and environment.							4	3		3	3	
<b>L</b>	Use assessment techniques, such as trend analysis and experimentation to make decisions about the future development of technology.							4	3		4		
<b>M</b>	Design forecasting techniques to evaluate the results of altering natural systems.							4	3			4	

## Standards for Technological Literacy Program Responsibility Matrix

### KEY

4 = Benchmark must be covered in detail, lessons and assessments cover this content  
 3 = Benchmark is covered, but topics and lessons do not center on them  
 2 = Topics and lessons refer to previous knowledge and integrate content covered  
 1 = Topics and lessons refer to previous knowledge

Course Total	172	232	212	147	166	202	154	97	182	236	209	187
	K-2	3-5	Exploring Technology	Invention & Innovation	Systems	Foundations	Impacts	Issues	Technological Design	Advanced Design Applications	Advanced Technological Applications	Engineering Design

### The Designed World

STL-14 Understanding of and abilities to select and use medical technologies		12	12	14	0	8	4	4	4	0	0	12	0
<b>A</b>	Vaccinations protect people from getting certain diseases.	4											
<b>B</b>	Medicine helps people who are sick to get better.	4											
<b>C</b>	There are many products designed specifically to help people take care of themselves.	4											
<b>D</b>	Vaccines are designed to prevent diseases from developing and spreading; medicines are designed to relieve symptoms and stop diseases from developing.		4										
<b>E</b>	Technological advances have made it possible to create new devices, to repair or replace certain parts of the body, and to provide a means for mobility.		4										
<b>F</b>	Many tools and devices have been designed to help provide clues about health and to provide a safe environment.		4										
<b>G</b>	Advances and innovations in medical technologies are used to improve healthcare.			4									
<b>H</b>	Sanitation processes used in the disposal of medical products help to protect people from harmful organisms and disease, and shape the ethics of medical safety.			4									
<b>I</b>	The vaccines developed for use in immunization require specialized technologies to support environments in which a sufficient amount of vaccines are produced.			3		4							
<b>J</b>	Genetic engineering involves modifying the structure of DNA to produce novel genetic make-ups.			3		4							
<b>K</b>	Medical technologies include prevention and rehabilitation, vaccines and pharmaceuticals, medical and surgical procedures, genetic engineering, and the systems within which health is protected and maintained.							4				4	
<b>L</b>	Telemedicine reflects the convergence of technological advances in a number of fields, including medicine, telecommunications, virtual presence, computer engineering, informatics, artificial intelligence, robotics, materials science, and perceptual psycho						4					4	
<b>M</b>	The sciences of biochemistry and molecular biology have made it possible to manipulate the genetic information found in living creatures.								4			4	

## Standards for Technological Literacy Program Responsibility Matrix

### KEY

4 = Benchmark must be covered in detail, lessons and assessments cover this content  
 3 = Benchmark is covered, but topics and lessons do not center on them  
 2 = Topics and lessons refer to previous knowledge and integrate content covered  
 1 = Topics and lessons refer to previous knowledge

### Course Total

		172	232	212	147	166	202	154	97	182	236	209	187
		K-2	3-5	Exploring Technology	Invention & Innovation	Systems	Foundations	Impacts	Issues	Technological Design	Advanced Design Applications	Advanced Technological Applications	Engineering Design
<b>STL-15 Understanding of and abilities to select and use agricultural and biotechnologies</b>		<b>8</b>	<b>12</b>	<b>12</b>	<b>4</b>	<b>4</b>	<b>4</b>	<b>4</b>	<b>7</b>	<b>4</b>	<b>0</b>	<b>16</b>	<b>4</b>
<b>A</b>	The use of technologies in agriculture makes it possible for food to be available year round and to conserve resources.	4											
<b>B</b>	There are many different tools necessary to control and make up the parts of an ecosystem.	4											
<b>C</b>	Artificial ecosystems are human-made environments that are designed to function as a unit and are comprised of humans, plants, and animals.		4										
<b>D</b>	Most agricultural waste can be recycled.		4										
<b>E</b>	Many processes used in agriculture require different procedures, products, or systems.		4										
<b>F</b>	Technological advances in agriculture directly affect the time and number of people required to produce food for a large population.			4									
<b>G</b>	A wide range of specialized equipment and practices is used to improve the production of food, fiber, fuel, and other useful products and in the care of animals.					4							
<b>H</b>	Biotechnology applies the principles of biology to create commercial products or processes.				4								
<b>I</b>	Artificial ecosystems are human-made complexes that replicate some aspects of the natural environment.			4									
<b>J</b>	The development of refrigeration, freezing, dehydration, preservation, and irradiation provide long-term storage of food and reduce the health risks caused by tainted food.			4									
<b>K</b>	Agriculture includes a combination of businesses that use a wide array of products and systems to produce, process, and distribute food, fiber, fuel, chemical, and other useful products.						4					4	
<b>L</b>	Biotechnology has applications in such areas as agriculture, pharmaceuticals, food and beverages, medicine, energy, the environment, and genetic engineering.							4	3			4	
<b>M</b>	Conservation is the process of controlling soil erosion, reducing sediment in waterways, conserving water, and improving water quality.								4			4	
<b>N</b>	The engineering design and management of agricultural systems require knowledge of artificial ecosystems and the effects of technological development on flora and fauna.									4		4	4

# Standards for Technological Literacy Program Responsibility Matrix

## KEY

4 = Benchmark must be covered in detail, lessons and assessments cover this content  
 3 = Benchmark is covered, but topics and lessons do not center on them  
 2 = Topics and lessons refer to previous knowledge and integrate content covered  
 1 = Topics and lessons refer to previous knowledge

### Course Total

		172	232	212	147	166	202	154	97	182	236	209	187
		K-2	3-5	Exploring Technology	Invention & Innovation	Systems	Foundations	Impacts	Issues	Technological Design	Advanced Design Applications	Advanced Technological Applications	Engineering Design
<b>STL-16 Understanding of and abilities to select and use energy and power technologies</b>		<b>8</b>	<b>8</b>	<b>12</b>	<b>0</b>	<b>8</b>	<b>12</b>	<b>6</b>	<b>3</b>	<b>17</b>	<b>20</b>	<b>0</b>	<b>17</b>
<b>A</b>	Energy comes in many forms.	4											
<b>B</b>	Energy should not be wasted.	4											
<b>C</b>	Energy comes in different forms.		4										
<b>D</b>	Tools, machines, products, and systems use energy in order to do work.		4										
<b>E</b>	Energy is the capacity to do work.			4									
<b>F</b>	Energy can be used to do work, using many processes.					4							
<b>G</b>	Power is the rate at which energy is converted from one form to another or transferred from one place to another, or the rate at which work is done.			4									
<b>H</b>	Power systems are used to drive and provide propulsion to other technological products and systems.					4							
<b>I</b>	Much of the energy used in our environment is not used efficiently.			4									
<b>J</b>	Energy cannot be created nor destroyed; however, it can be converted from one form to another.						4			3	4		3
<b>K</b>	Energy can be grouped into major forms: thermal, radiant, electrical, mechanical, chemical, nuclear, and others.						4			3	4		3
<b>L</b>	It is impossible to build an engine to perform work that does not exhaust thermal energy to the surroundings.							4		3	4		3
<b>M</b>	Energy resources can be renewable or nonrenewable.						1	2	3	4	4		4
<b>N</b>	Power systems must have a source of energy, a process, and loads.						3			4	4		4

## Standards for Technological Literacy Program Responsibility Matrix

### KEY

4 = Benchmark must be covered in detail, lessons and assessments cover this content  
 3 = Benchmark is covered, but topics and lessons do not center on them  
 2 = Topics and lessons refer to previous knowledge and integrate content covered  
 1 = Topics and lessons refer to previous knowledge

### Course Total

		172	232	212	147	166	202	154	97	182	236	209	187
		K-2	3-5	Exploring Technology	Invention & Innovation	Systems	Foundations	Impacts	Issues	Technological Design	Advanced Design Applications	Advanced Technological Applications	Engineering Design
<b>STL-17 Understanding of and abilities to select and use information and communication technologies</b>		<b>12</b>	<b>16</b>	<b>13</b>	<b>4</b>	<b>8</b>	<b>16</b>	<b>8</b>	<b>8</b>	<b>7</b>	<b>0</b>	<b>24</b>	<b>7</b>
<b>A</b>	Information is data that has been organized.	4											
<b>B</b>	Technology enables people to communicate by sending and receiving information over a distance.	4											
<b>C</b>	People use symbols when they communicate by technology.	4											
<b>D</b>	The processing of information through the use of technology can be used to help humans make decisions and solve problems.		4										
<b>E</b>	Information can be acquired and sent through a variety of technological sources, including print and electronic media.		4										
<b>F</b>	Communication technology is the transfer of messages among people and/or machines over distances through the use of technology.		4										
<b>G</b>	Letters, characters, icons, and signs are symbols that represent ideas, quantities, elements, and operations.		4										
<b>H</b>	Information and communication systems allow information to be transferred from human to human, human to machine, and machine to human.			3		4							
<b>I</b>	Communication systems are made up of a source, encoder, transmitter, receiver, decoder, and destination.			3		4							
<b>J</b>	The design of a message is influenced by such factors as the intended audience, medium, purpose, and nature of the message.			4									
<b>K</b>	The use of symbols, measurements, and drawings promotes clear communication by providing a common language to express ideas.			3	4								
<b>L</b>	Information and communication technologies include the inputs, processes, and outputs associated with sending and receiving information.						4					4	
<b>M</b>	Information and communication systems allow information to be transferred from human to human, human to machine, machine to human, and machine to machine.						4					4	
<b>N</b>	Information and communication systems can be used to inform, persuade, entertain, control, manage, and educate.						1	4	4			4	
<b>O</b>	Communication systems are made up of source, encoder, transmitter, receiver, decoder, storage, retrieval, and destination.						4					4	
<b>P</b>	There are many ways to communicate information, such as graphic and electronic means.							4	4	4		4	3
<b>Q</b>	Technological knowledge and processes are communicated using symbols, measurement, conventions, icons, graphic images, and languages that incorporate a variety of visual, auditory, and tactile stimuli.						3			4		4	4

## Standards for Technological Literacy Program Responsibility Matrix

### KEY

4 = Benchmark must be covered in detail, lessons and assessments cover this content  
 3 = Benchmark is covered, but topics and lessons do not center on them  
 2 = Topics and lessons refer to previous knowledge and integrate content covered  
 1 = Topics and lessons refer to previous knowledge

### Course Total

		172	232	212	147	166	202	154	97	182	236	209	187
		K-2	3-5	Exploring Technology	Invention & Innovation	Systems	Foundations	Impacts	Issues	Technological Design	Advanced Design Applications	Advanced Technological Applications	Engineering Design
<b>STL-18 Understanding of and abilities to select and use transportation technologies</b>		12	8	4	4	11	4	8	0	4	16	0	4
<b>A</b>	A transportation system has many parts that work together to help people travel.	4											
<b>B</b>	Vehicles move people or goods from one place to another in water, air, or space and on land.	4											
<b>C</b>	Transportation vehicles need to be cared for to prolong their use.	4											
<b>D</b>	The use of transportation allows people and goods to be moved from place to place.		4										
<b>E</b>	A transportation system may lose efficiency or fail if one part is missing or malfunctioning or if a subsystem is not working.		4										
<b>F</b>	Transporting people and goods involves a combination of individuals and vehicles.			4		3							
<b>G</b>	Transportation vehicles are made up of subsystems, such as structural, propulsion, suspension, guidance, control, and support, that must function together for a system to work effectively.					4							
<b>H</b>	Governmental regulations often influence the design and operation of transportation systems.				4								
<b>I</b>	Processes, such as receiving, holding, storing, loading, moving, unloading, delivering, evaluating, marketing, managing, communicating, and using conventions are necessary for the entire transportation system to operate efficiently.					4							
<b>J</b>	Transportation plays a vital role in the operation of other technologies, such as manufacturing, construction, communication, health and safety, and agriculture.						4				4		
<b>K</b>	Intermodalism is the use of different modes of transportation, such as highways, railways, and waterways as part of an interconnected system that can move people and goods easily from one mode to another.							4			4		
<b>L</b>	Transportation services and methods have led to a population that is regularly on the move.							4			4		
<b>M</b>	The design of intelligent and non-intelligent transportation systems depends on many processes and innovative techniques									4	4		4



## Standards for Technological Literacy Program Responsibility Matrix

### KEY

4 = Benchmark must be covered in detail, lessons and assessments cover this content  
 3 = Benchmark is covered, but topics and lessons do not center on them  
 2 = Topics and lessons refer to previous knowledge and integrate content covered  
 1 = Topics and lessons refer to previous knowledge

### Course Total

		172	232	212	147	166	202	154	97	182	236	209	187
		K-2	3-5	Exploring Technology	Invention & Innovation	Systems	Foundations	Impacts	Issues	Technological Design	Advanced Design Applications	Advanced Technological Applications	Engineering Design
STL-19 Understanding of and abilities to select and use manufacturing technologies		8	12	12	8	4	10	15	3	14	24	0	15
<b>A</b>	Manufacturing systems produce products in quantity.	4											
<b>B</b>	Manufactured products are designed.	4											
<b>C</b>	Processing systems convert natural materials into products.		4										
<b>D</b>	Manufacturing processes include designing products, gathering resources, and using tools to separate, form, and combine materials in order to produce products.		4										
<b>E</b>	Manufacturing enterprises exist because of a consumption of goods.		4										
<b>F</b>	Manufacturing systems use mechanical processes that change the form of materials through the processes of separating, forming, combining, and conditioning them.			4									
<b>G</b>	Manufactured goods may be classified as durable and non-durable.			4									
<b>H</b>	The manufacturing process includes the designing, development, making, and servicing of products and systems.					4							
<b>I</b>	Chemical technologies are used to modify or alter chemical substances.				4								
<b>J</b>	Materials must first be located before they can be extracted from the earth through such processes as harvesting, drilling, and mining.			4									
<b>K</b>	Marketing a product involves informing the public about it well as assisting in selling and distributing it.				4								
<b>L</b>	Servicing keeps products in good operating condition.							4					
<b>M</b>	Materials have different qualities and may be classified as natural, synthetic, or mixed.						4	3		3	4		3
<b>N</b>	Durable goods are designed to operate for a long period of time, while non-durable goods are designed to operate for a short period of time.									4	4		4
<b>O</b>	Manufacturing systems may be classified into types, such as customized production, batch production, and continuous production.						3			3	4		4
<b>P</b>	The interchangeability of parts increases the effectiveness of manufacturing processes.						3			4	4		4
<b>Q</b>	Chemical technologies provide a means for humans to alter or modify materials and to produce chemical products.							4			4		
<b>R</b>	Marketing involves establishing a product's identity, conducting research on its potential, advertising it, distributing it, and selling it.							4	3		4		

## Standards for Technological Literacy Program Responsibility Matrix

### KEY

4 = Benchmark must be covered in detail, lessons and assessments cover this content  
 3 = Benchmark is covered, but topics and lessons do not center on them  
 2 = Topics and lessons refer to previous knowledge and integrate content covered  
 1 = Topics and lessons refer to previous knowledge

### Course Total

		172	232	212	147	166	202	154	97	182	236	209	187
		K-2	3-5	Exploring Technology	Invention & Innovation	Systems	Foundations	Impacts	Issues	Technological Design	Advanced Design Applications	Advanced Technological Applications	Engineering Design
<b>STL-20 Understanding of and abilities to select and use construction technologies</b>		8	12	7	0	12	8	4	0	11	20	0	11
<b>A</b>	People live, work, and go to school in buildings, which are of different types: houses, apartments, office buildings, and schools.	4											
<b>B</b>	The type of structure determines how the parts are put together.	4											
<b>C</b>	Modern communities are usually planned according to guidelines.		4										
<b>D</b>	Structures need to be maintained.		4										
<b>E</b>	Many systems are used in buildings.		4										
<b>F</b>	The selection of designs for structures is based on factors such as building laws and codes, style, convenience, cost, climate, and function.			4									
<b>G</b>	Structures rest on a foundation.			3		4							
<b>H</b>	Some structures are temporary, while others are permanent.					4							
<b>I</b>	Buildings generally contain a variety of subsystems.					4							
<b>J</b>	Infrastructure is the underlying base or basic framework of a system.						4				4		
<b>K</b>	Structures are constructed using a variety of processes and procedures.						4				4		
<b>L</b>	The design of structures includes a number of requirements.									4	4		4
<b>M</b>	Structures require maintenance, alteration, or renovation periodically to improve them or to alter their intended use.									3	4		3
<b>N</b>	Structures can include prefabricated materials									4	4		4

National Aeronautics and Space Administration

**George C. Marshall Space Flight Center**

Huntsville, AL 35812

[www.nasa.gov/marshall](http://www.nasa.gov/marshall)

[www.nasa.gov](http://www.nasa.gov)