

Rocket Activity

Newton Car

Objectives

To investigate the relationship between mass, acceleration, and force as described in Newton's second law of motion.

Description

Small student teams use a wooden car and rubber bands to toss a small mass off the car. The car, resting on rollers, will be propelled in the opposite direction. During a set of experiments, students will vary the mass being tossed from the car and change the number of rubber bands used to toss the mass. Students will measure how far the car rolls in response to the action force generated.

Materials

- Newton Cars (see separate instructions)
- Cotton string
- Two rubber bands (size 19)
- Medicine bottles (see Tip)
- 25 straight drinking straws (not flex)
- Meter stick or ruler
- Metric beam balance or scale Scissors or lighters (see Management below)
- Popcorn seeds, washers, pennies, marbles, paper clips, etc. (for filling the bottles)
- Eye protection

Management

This activity requires a smooth floor or long tables for a rolling surface. Be sure teams understand how to set up the car and are consistent in their placement of straws. Demonstrate the "loading" of the car. After attaching the rubber band and string to the car, press the bottle into the "V" of the rubber bands. This process must be done the same way each time. Also demonstrate the string cutting process. The string must be cut and the

scissors moved out of the way in one smooth and quick movement. Lighters can also be used for burning through the string. Have students light the ends of the string dangling down from the knot. The flame will climb up the strings and burn through the knot. Students must wear eye protection with either string cutting technique.

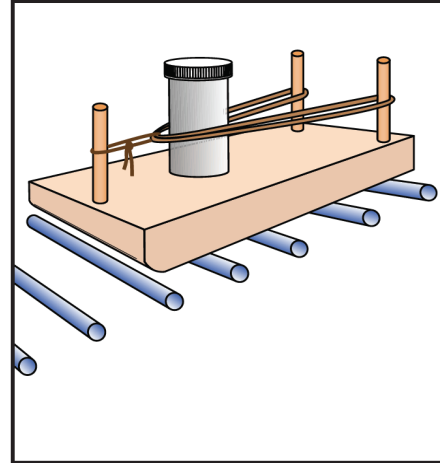

National Science Content Standards

Unifying Concepts and Processes

- Evidence, models, and explanation
- Change, constancy, and measurement

Science as Inquiry

- Abilities necessary to do scientific inquiry

Physical Science

- Position and motion of objects
- Motions and forces
- Properties of objects and materials

Science and Technology

- Understanding about science and technology

National Mathematics Content Standards

- Number and Operations
- Measurement
- Data Analysis and Probability

National Mathematics Process Standards

- Problem Solving
- Reasoning and Proof
- Communication
- Connections
- Representations

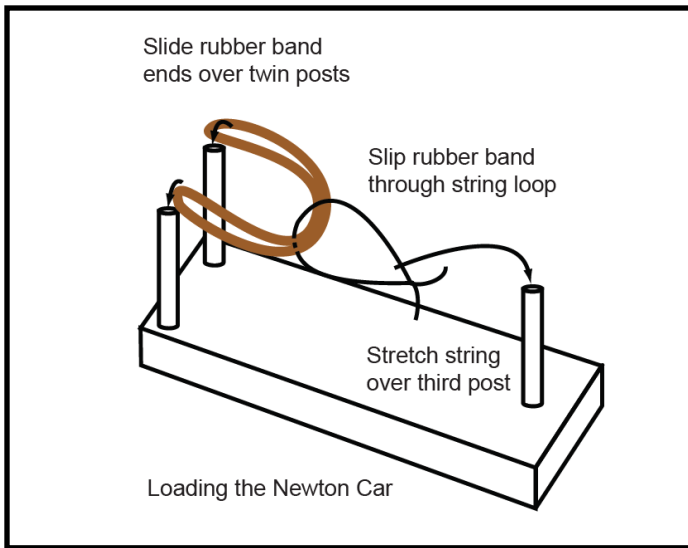

Background

Although the purpose of the Newton Car is to investigate Newton's second law of motion, it provides an excellent demonstration of all three laws. The car is a slingshot-like device. Rubber bands are stretched between two posts and held with a string loop ringing a third post. A bottle, holding various materials that can be changed to vary its mass, is placed between the stretched rubber bands. When the string is cut, the bottle is tossed off the car and the car travels the other way on straw rollers.

Newton's first law is demonstrated by the act of exerting a force. The car remains at rest until the mass is expelled, producing a force. The car then moves. The action force exerted on the car produces an equal and opposite reaction force. The car moves the other way from the tossed bottle. This demonstrates Newton's third law.

How far the car moves demonstrates the second law. The magnitude of the force is determined by how much mass is tossed and how fast it is accelerated off the car.

By varying the mass and the number of rubber bands, students are able to see a visual demonstration of the relationship of mass and acceleration on force. The greater the mass of the bottle and its contents

and the greater the acceleration (more rubber bands), the greater the force. The effect is that the car will travel further in the opposite direction. (Refer to pages 21 – 25 for a more detailed explanation of Newton's laws of motion.)

Materials

- 1 1 X 3 X 8 in. board*
- 3 1/4" diameter by 2 1/2" long dowels (or wood screws)
- Wood glue

Procedure

Making Newton Cars

1. Cut the board into 12 8 in. lengths. (Optional: Bevel one edge as shown on the previous page.)
2. Drill three 1/4 in. holes 3/8 in. deep for the dowels. If using screws for posts instead of dowels, skip Step 3.
3. Glue the dowels into the holes. If desired, bevel the upper end of the dowels with sand paper.

* Note: Dimensions of lumber are based on rough cuts. When planed, thickness and width are smaller. A 1X3-in. board is actually 0.75 by 2.5 in.

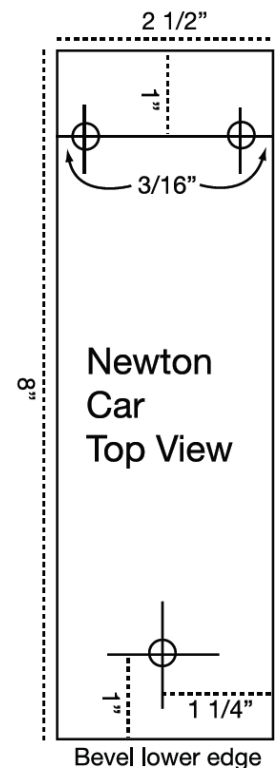

Procedure

The Experiment

1. Provide student teams with the instruction sheet on how to set up the Newton Car and the data sheet.
2. Clear areas for each team to set up their experiment.
3. Provide a station where teams can fill their bottles with different materials to change their total mass. Place the popcorn seeds, washers, etc., in different bowls for easy access. The bottles do not have to be filled to the top. However, the rubber bands should be positioned around the approximate center of mass of the bottle to get a uniform toss.
4. Check each team to ensure they are being consistent in their procedures. For instance, placing straws differently for each test would introduce a new variable into the experiment that could affect the results.

Tip Provide masking tape so that students can use small tape pieces to mark the positions of the straws for consistency.

Discussion

- How does adding additional rubber bands change the acceleration?

Like all matter, the bottle has inertia, which is the property of resistance to change in motion. Newton's first law of motion is often referred to as the law of inertia. A force is needed to change the motion of the bottle. In this experiment the inertia of the bottle retards the contraction of the rubber band. Two rubber bands, working together, are able to contract more rapidly and consequently are able to impart a greater acceleration to the bottle.

Tip Ask a pharmacist for a donation of new, 8-dram size medicine bottles.

Assessment

- Review the experiment report for completeness and check team statements, explaining the relationship between mass, acceleration, and the distances the Newton Cars traveled.
- Ask students for other examples of Newton's laws of motion at work.

Extensions

- Newton's second law of motion can also be demonstrated using a water rocket. Vary the pressure in the water rocket by using different numbers of pumps. Vary the amount of water inside the bottle. Changes in mass and acceleration will affect the performance of the rocket in flight.

Heavy Lift Rocket Mission Report

1. Tie six string loops approximately this size.



2. Fill the plastic bottle with small weights provided by your teacher. Measure the mass of the filled bottle and record the amount on your data sheet for test 1.

3. Set up your Newton Car as shown in the picture. Slide the rubber band through the first string loop. Slip the ends of the rubber band over the two posts. Pull the string back to stretch the rubber bands, and slip the loop over the third post to hold the loop.

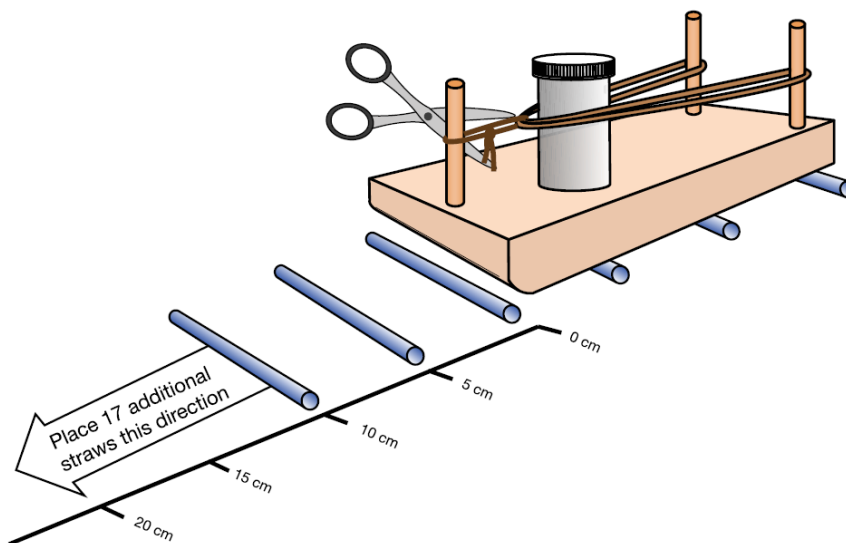
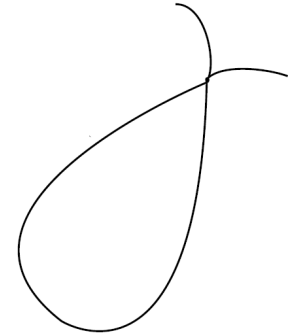

4. Lay the straws on a smooth floor or tabletop. Place them like railroad ties 5 cm apart. Put the Newton Car on top of the straws at one end of the line.

5. Using the scissors, cut the string. Quickly move the scissors out of the way! The rubber band will toss the bottle off the Newton Car while the car rolls the other way on the straws.

6. Measure how far the Newton Car moved and record the distance on the data sheet.

7. Repeat the experiment using two rubber bands. Be sure to set up the straws and place the Newton Car on them exactly as before. Record your data.

8. Put different weights in the bottle and measure its mass. Record the mass and repeat the experiment with one and two rubber bands. Record your data.

9. Once more, put different weights in the bottle and measure its mass. Record the mass and repeat the experiment with one and two rubber bands. Record your data.

10. Answer the questions on the data sheet and write a general statement about the relationship between the mass and number of rubber bands used and the distance the Newton Car travels.

Newton Car Experiment Report

Team Member Names: _____

	Mass of Bottle	Number of Rubber Bands	Distance Car Traveled
Test 1		1	
		2	
Test 2		1	
		2	
Test 3		1	
		2	

Did the number of rubber bands affect how far the Newton Car moved? Describe what happened.

Did the mass of the bottle affect how far the Newton Car moved? Describe what happened.

Construct a bar graph showing how far the Newton Car moved for each test.

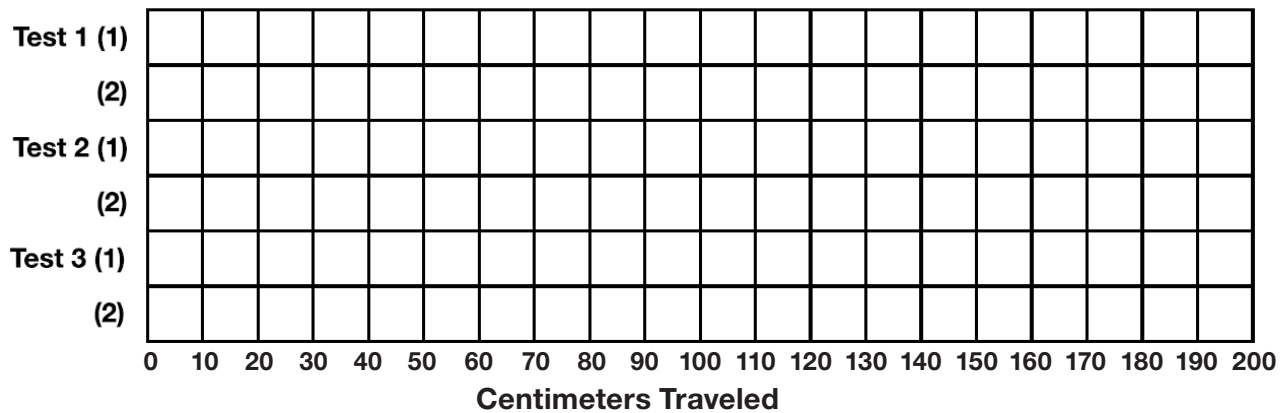

On the back of this page write a short statement explaining the relationship between the amount of mass in the bottle, the number of rubber bands used, and the distance the Newton Car traveled.