

Space-Based, On-Demand Fabrication of Metallic Parts Using Additive Manufacturing

K. M. Taminger¹, C. M. Tolbert², E. D. Baumann², K. G. Cooper³,
R. A. Hafley¹, C. A. McLemore³ and M. C. Waid⁴

¹NASA Langley Research Center

²NASA Glenn Research Center

³NASA Marshall Space Flight Center

⁴NASA Johnson Space Center

June 26-28, 2012

1st Annual International Space Station
Research & Development Conference
Denver, CO

Supportability of Long-Term Human Exploration Missions



- **On-demand fabrication of metallic parts using additive manufacturing**
 - Fabricate replacement parts, new tools or repair damaged components
 - Long term: recycle broken parts to provide feedstock to fabricate replacement parts
- **ISS is an ideal testbed for technology demonstration for future exploration missions**
- **Supportability concept is enabling for longer missions to distant destinations**
 - Lengthy travel times with existing launch and propulsion systems makes re-supply from Earth an impossibility

Technology Development for Supportability Concepts



- ISS as a technology testbed:
 - Relevant environment (0-g)
 - Human (astronaut) involvement possible for testing technologies
 - Control from Earth without appreciable time lags
- Current (ground-based) efforts are developing framework and demonstrating key components
 - Design, build, finish, inspect, certification of parts, communications protocols
 - Current activities all on Earth to reduce risk and develop technologies for use in space
- Effort includes researchers at four NASA centers: GRC, JSC, LaRC, MSFC

Design of Additive Manufactured Metallic Part



Basics:

- U.S. liquid rocket engine manufacturers are experimenting with additive manufacturing techniques for next generation rocket engine components
- Focus on GH_2/LOX injectors representative of in-space engine
- Intricate metal parts are being produced by sintering layers of powder using an electron beam or laser
- Demo sub-scale additively manufacture rocket engine injectors under hot-fire conditions

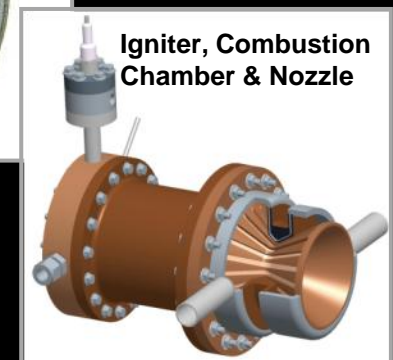
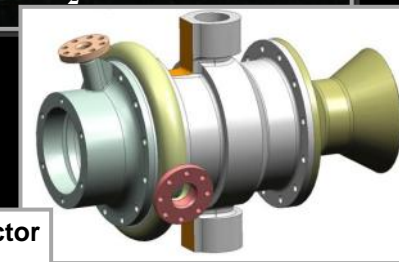
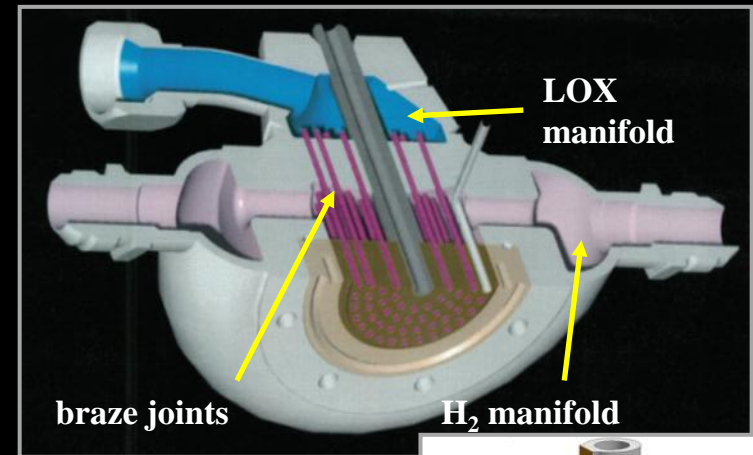

Benefits:

- Reduce injector manufacture time from months to weeks
- Potential to reduce full scale injector cost by nearly an order of magnitude (~90% reduction)
- Successful hot-fire experiments will infuse additive manufacturing tech into US rocket engine industrial base
- Demo capability to build in-space rocket engine injector

Candidate Metal Additive Process: Electron Beam Freeform Fabrication (EBF³)



Basics:

- Layer-additive process to build parts using CNC techniques
- Electron beam melts pool on substrate, metal wire added to build up part
- Successfully demonstrated in 0-g during parabolic flight tests
- Demonstrating design and build of candidate replacement part for finishing and testing in ground-system testbed
- Developing S-basis allowables and modeling to predict properties for certification

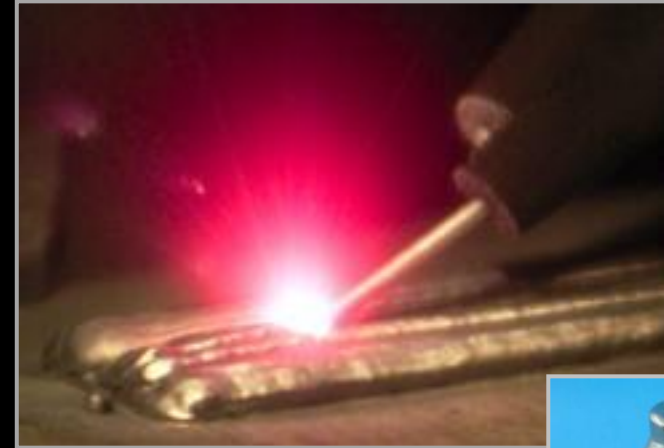

Benefits:

- High energy efficiency and feedstock usage efficiency compatible with space-based operations
- Electron beam can be modulated to perform multiple operations (welding, deposition, heating, surface modification, machining, etc.)
- Wire feedstock safely handled in reduced gravity
- Can process wide variety of metallic materials

Inspection and Finishing of Near-Net Shape Metallic Components

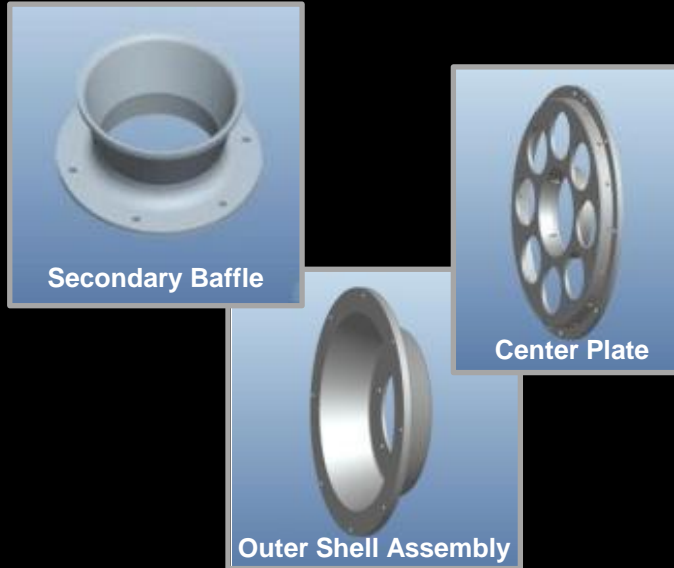
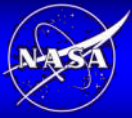

Basics:

- Ground-based concept of operations demonstrating components can be designed, fabricated, finished and inspected
- Selected Ti-6-4 assembly from Environmental Control and Life Support System (ECLSS) on ISS

- Finishing and inspection system concept includes:
 - Miniature milling machine, studying chip containment, vibration and noise issues for compatibility with ISS environment
 - 3D white light scanner for surface inspection
 - Proposed operation in Microgravity Sciences Glovebox on ISS

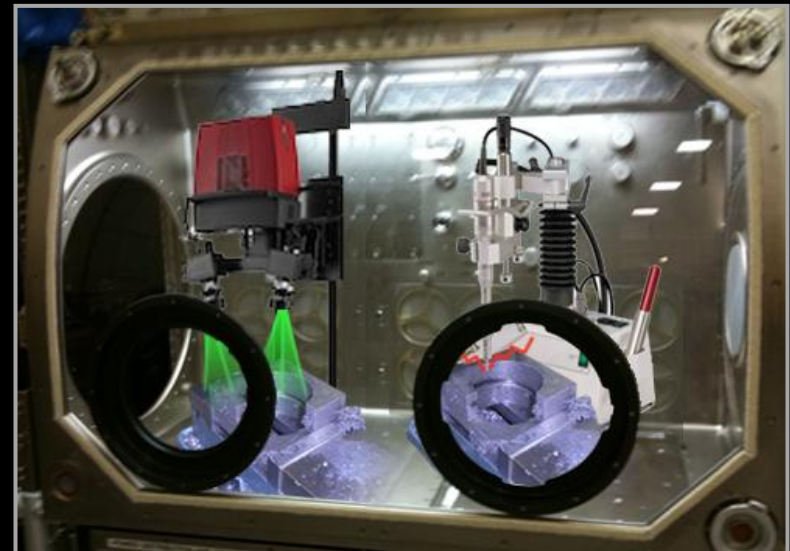

Certification of Additively Manufactured Parts



- Demonstrate flight certification process for additive manufactured metal part
- EVA tool used during STS-135
- Design load of 45 lbs.
- Qualification unit tested to failure at 440 lbs.
- Certification not pursued due to flight schedule
- Additional EBF³ components now being evaluated for potential flight certification
- Developing S-basis allowables on various alloys to aide in certification assessments

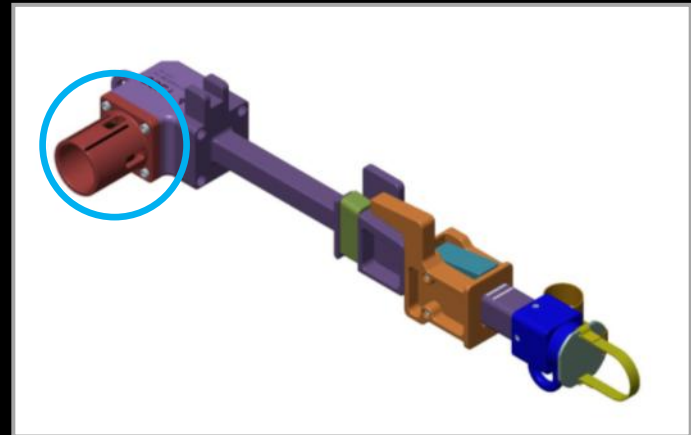

Remote Access and Operability of Deployed Additive Manufacturing System



- Integrated Power, Avionics, and Software (iPAS) facility is intended to be an integrated hardware/software test and evaluation environment
- Provide a common testbed framework that supports integrated hardware/software testing for a variety of applications
- Planned demonstration of EBF³ system connected through iPAS for data transfer and remote system control
- Establish a simple “reference mission”
 - Part to be built
 - Role of ground personnel and crew
- Create Interface Control Document (ICD)
 - Identify the data to be passed to Crew/MCC
 - Possible file uploads or commands to system
 - Define format for exchanging data
- Establish Data Connectivity through DSNet
- Demonstrate ability to produce part in one location, while all command and control, including data evaluation for qualification and certification, is conducted at a separate location

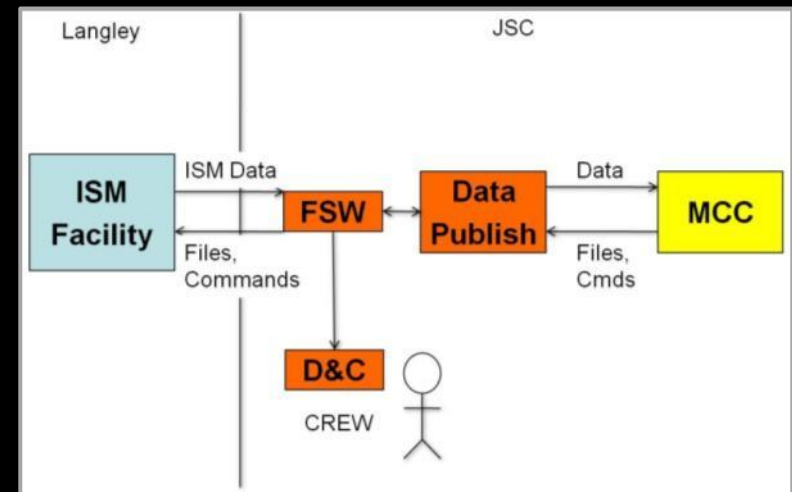

Space-Based, On-Demand Fabrication of Metallic Parts Using Additive Manufacturing



Summary:

- Supportability is critical for longer duration, more remote exploration missions
- Currently working series of development activities to demonstrate concept of operations for space-based on-demand additive manufacturing
- ISS is an ideal platform for testing efficacy of on-demand additive manufacturing in a relevant space environment
- If demonstration on ISS is conducted, equipment provides residual capability for use on ISS beyond proof-of-concept experiments