



Mass vs. Weight

Air Powered Mass

Objective

To investigate Newton's Second Law of motion, $F = ma$, by measuring how objects of different mass are accelerated by a constant force.

Description

Student teams build a **mass car** and measure its movement in relation to the amounts of mass it carries as it is propelled by a uniform air blast. Following data collection, students graph and discuss their results and compare it to the video of a similar experiment performed on the International Space Station.

Materials (per student team)

- Mass Car Template (copied onto card stock paper)
- 4 oz paper or plastic drinking cup
- 15 non-flexible, solid color drinking straws (each cut in half)
- Party balloon air pump
- Mass scale
- Scissors
- Cellophane tape (any classroom tape will work)
- Meter stick
- Graphing paper
- 15 pennies (or flat washers approximately 2.5 g each)
- Safety goggles
- Copies of the Student Data Sheets
- *Mass vs. Weight "Air Powered Mass" video clip*

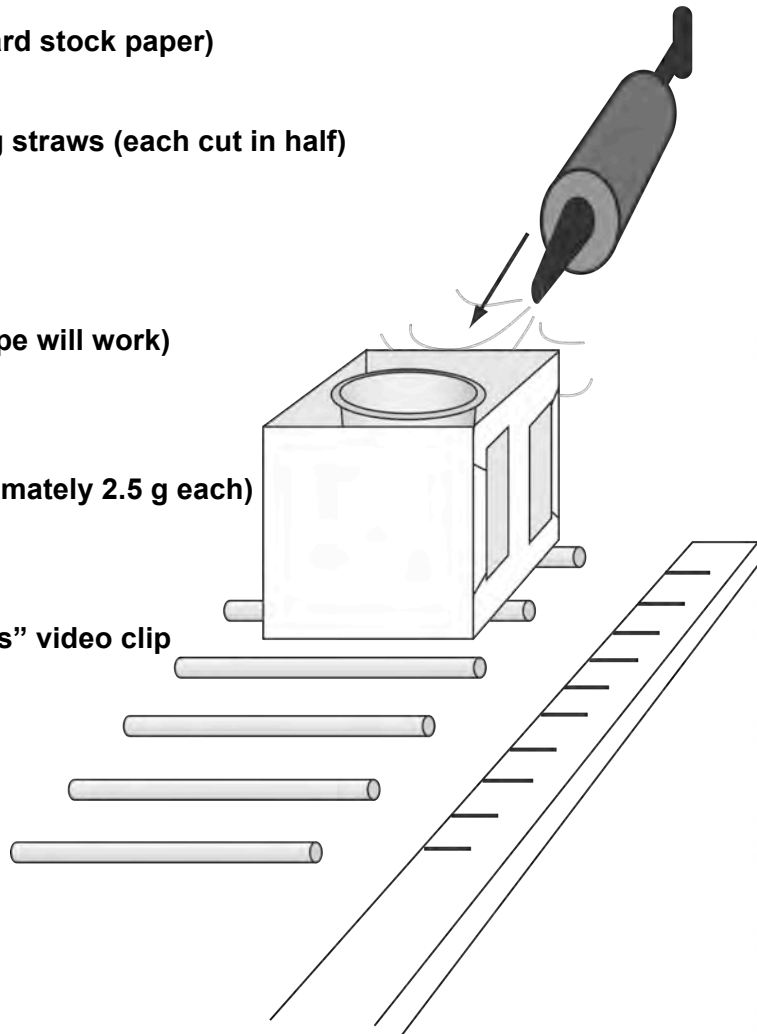

mass vs weight

Management

Prepare your students for the experiment by reviewing the importance of controlling variables in experiments. In this investigation, there are many variables (e.g. spacing and straightness of the straws, placement of the car, uniform air blast from the pump, etc.). This activity requires a smooth uncarpeted floor or long, level table for a rolling surface. Designate areas for each team to set-up their experiment. Check each student team to make sure they are being consistent in setting up the mass car and placing the straws. Demonstrate how to "load" the mass in the car. The cup, with pennies inside, must be placed on the shaded circle. Also ensure that the students target the blast of air in the same spot on the car to minimize variables. In place of pennies, washers that have approximately the same mass as a penny (2.5g) can be used.

Background

For background information, refer to the *Newton's Laws of Motion Introduction* brief.

Procedure

1. Copy the Mass Car Template onto card stock paper. Provide each student team with a template and have them construct the Mass Car.
2. Provide each student team with a Mass Car Experiment Procedures sheet. Have them read the written directions on how to conduct the experiment and how to record their data on the Student Data Sheet. Be sure students **practice safety, wear goggles** and **stay alert** during this experiment.
3. At the completion of the experiment, have students discuss their observations and conclusions. *How did the movement of the mass car change when you increased its mass? How does Newton's second law of motion apply to this investigation?* With a constant propelling force, the acceleration of the car is reduced when the mass is increased, $F=ma$. *Would the results be the same if you did the same experiment in the microgravity environment on-board the ISS?*
4. View the *Mass vs. Weight* "Air Powered Mass" video clip and have students relate the ISS experiment results to their own results.

Assessment

1. Review student Mass Car data and graph sheets.
2. Discuss with the students what would happen if more tests were performed and mass was continuously added.
3. Discuss the variables in the experiment (i.e. The angle of the air gun, force of air etc.) and how these variables can be controlled.

Extensions

1. Students compare each team's data and determine the mean, median, and mode of the class test results.
2. Using gathered data, place an unknown amount of mass in the mass car and instruct students to determine the unknown amount of mass.
3. Discuss with students other examples of Newton's second law of motion at work. (e.g. a semi truck requires much more engine force to accelerate from a stop light as does a passenger car.)
4. For a more durable experiment set-up, short lengths of wooden dowels can be used in place of straws for the Mass Car to travel over. The dowels need to be uniform in length and diameter and sanded smooth.

Standards

National Science Education Standards

Unifying Concept and Processes

- Evidence, models, and explanation
- Change, constancy, and measurement

Science as Inquiry

- Abilities necessary to do scientific inquiry

Physical Science

- Motions and Forces

History and Nature of Science

- Science as a human endeavor

Principles and Standards for School Mathematics

(refer to *Mass vs. Weight* "Introduction" for complete standards)

Number and Operations

- Understand numbers
- Understand meanings
- Compute fluently

Measurement

- Understand measurable attributes
- Apply appropriate techniques

Data Analysis and

Probability

- Formulate questions
- Select and use methods
- Develop and evaluate inferences
- Understand and apply

Process Standards

- Problem Solving
- Communication
- Connections
- Representation

Name: _____

Air Powered Mass
Student Team Experiment Procedures

**PRACTICE SAFETY – WEAR
GOGGLES – STAY ALERT**

1. Construct the Mass Car using the provided template.
2. Cut fifteen standard straight straws in half to make 30 shorter straw pieces.
3. Place a meter stick on a smooth floor or tabletop. Put one straw next to the end of the meter stick. Place the second straw parallel to the first at the 2-centimeter mark. Continue placing all the other straws 2 centimeters apart. Be sure the straws are not touching the meter stick. The straws should be parallel to each other like the wooden ties of railroad tracks.
4. Set the Mass Car on the straws with the back of the car even with the 0 centimeter straw.
5. Carefully place an empty cup on top of the shaded circle inside the box of the mass car. Measure the mass of the mass car and empty cup. Record mass on the chart on Student Data Sheet
6. Aim the nozzle of the balloon pump straight at the target on the back of the mass car. Shoot a blast of air at the car and observe what happens. Reset the straws and car and propel it again several times until the car always moves the same distance every time.
7. Begin the experiment by resetting the straws and car. Propel the car with the balloon pump and measure how far the car traveled. Record the distance on the data sheet.
8. Reset the straws and car but place 5 pennies into the cup. Propel the car and measure how far it goes with the extra mass. Record your data.
9. Repeat experiment two more times with 10 and then 15 pennies.
10. Record and graph your data for each test on the Student Data Sheet.

Aim the balloon pump at the NASA emblem each time

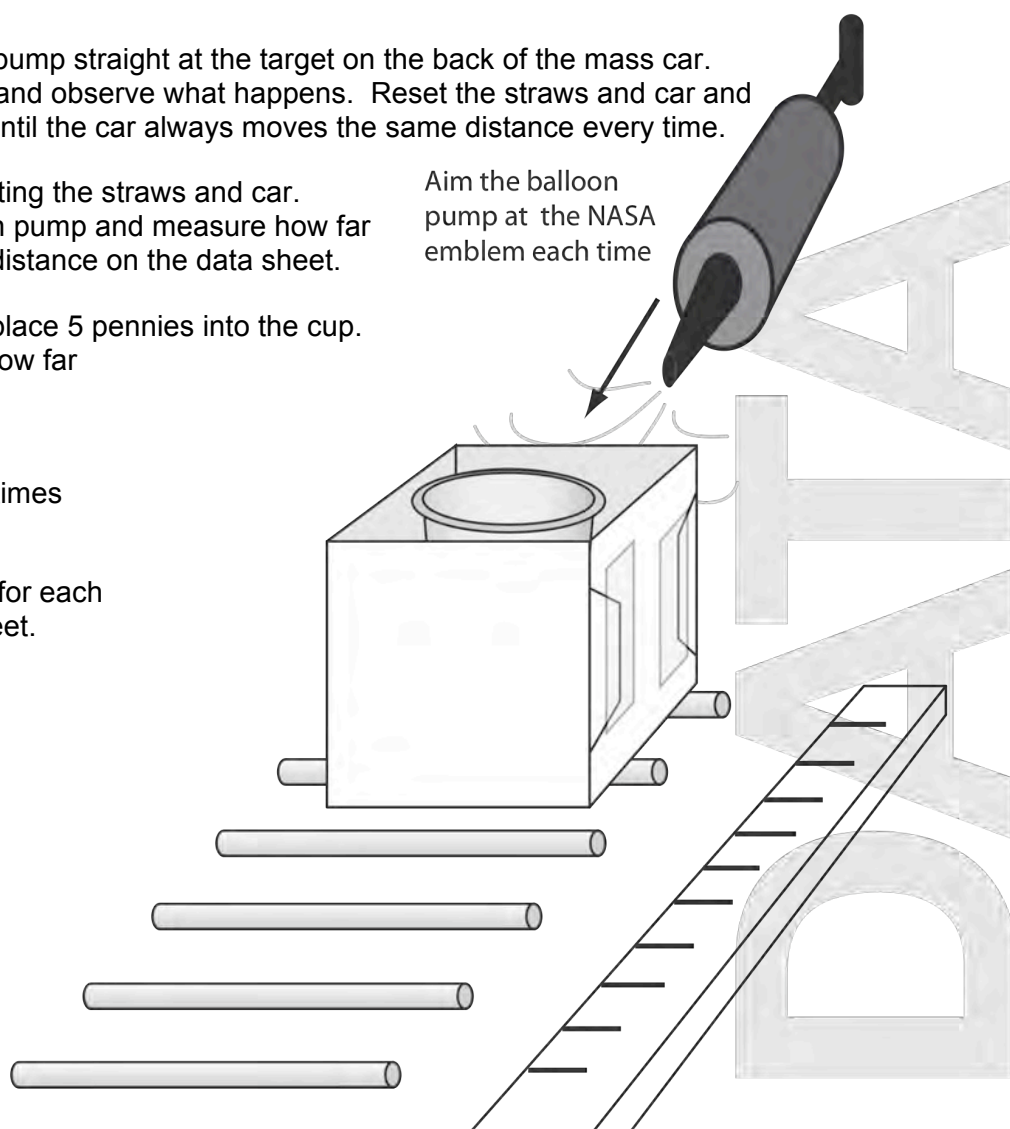

Name: _____

**Air Powered Mass
Student Data Sheet**

Items	Total Mass (g)	Distance Mass Car Traveled (cm)			
		Test 1	Test 2	Test 3	Average
Car + Cup + 0 pennies					
Car + Cup + 5 pennies					
Car + Cup + 10 pennies					
Car + Cup + 15 pennies					

1. Plot the bar graph showing the average distance of the three tests for each mass:

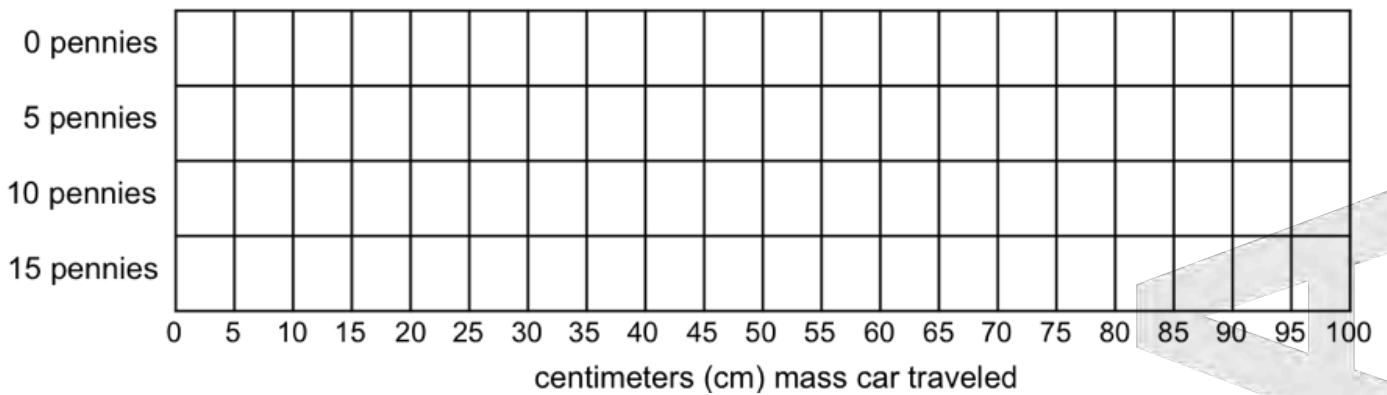

2. Plot the data on graph paper as a line graph. Give the graph a title and label the axes. Include the units.

3. Examine the data and the graphs. How does the mass affect the distance the mass car traveled?

4. How can Newton's Laws of Motion explain the data results?

5. How would this experiment work on the International Space Station? (Use the back of the sheet if needed)

Mass Car Template

Instructions:

1. Cut on solid lines.
2. Fold on dashed lines.
3. Fold up sides A and B.
4. Fold up side C.
5. Fold tabs D and E around sides A and B. Tape them.
6. Fold up side F.
7. Fold down side G.
8. Fold tabs H and I around sides A and B. Tape them.

The Box is ready.

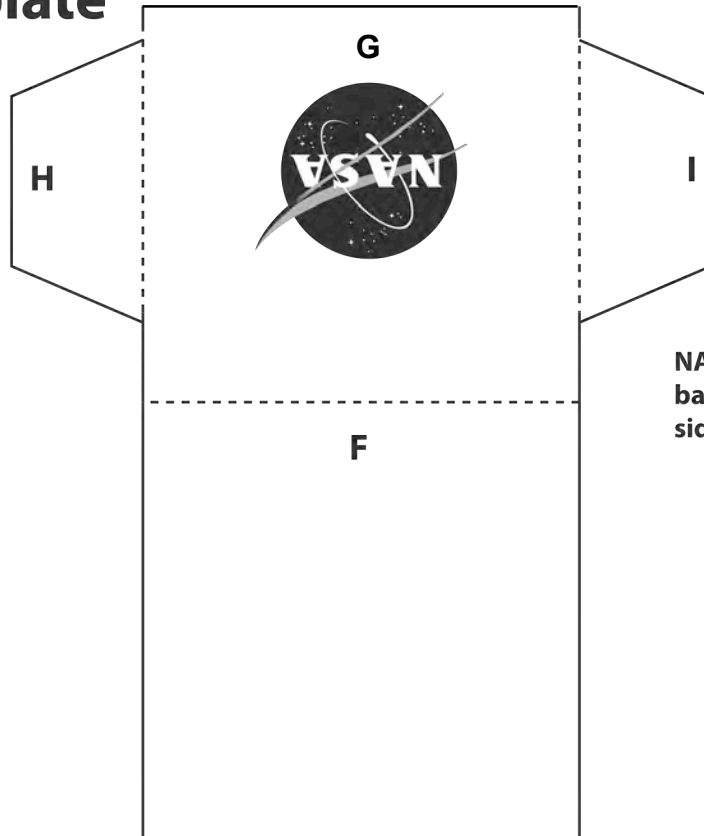

NASA Emblem on
back of
side F.

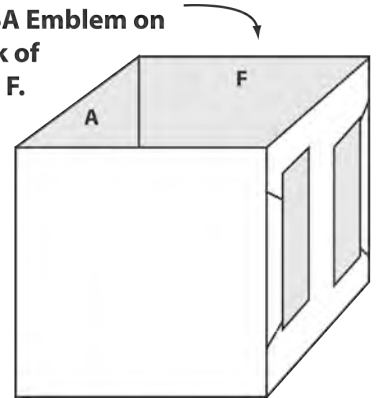

Box Folded and Taped

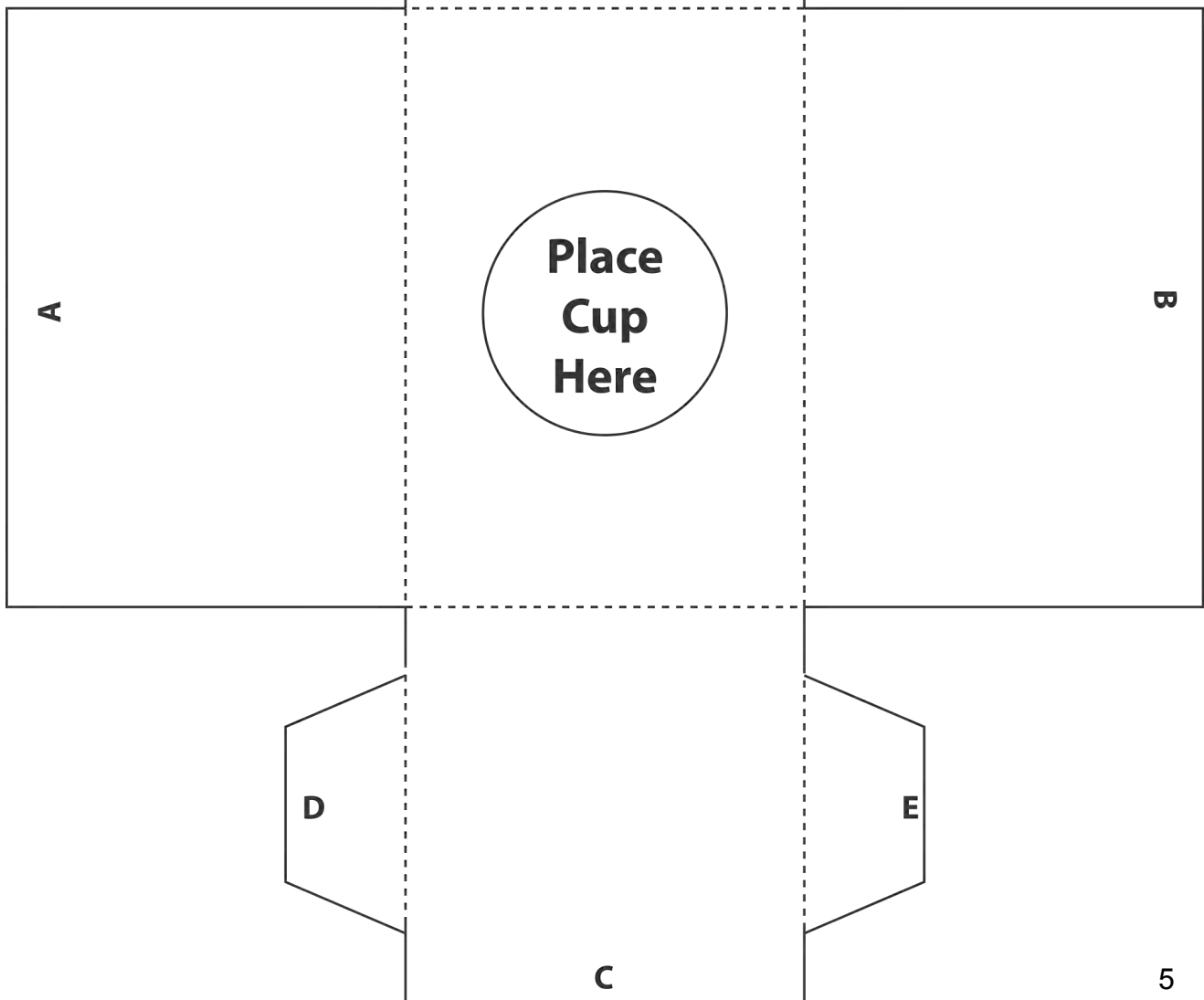

Newton's Laws of Motion Introduction

Excerpt from *Rockets: Educator Guide With Activities in Science, Technology, Engineering and Mathematics* (EG-2008-05-060-KSC)

In his master work entitled *Philosophia Naturalis Principia Mathematica* (usually referred to as *Principia*), Isaac Newton stated his laws of motion. For the most part, the laws were known intuitively by rocketeers, but their statement in clear form elevated rocketry to a science. Practical application of Newton's laws makes the difference between failure and success. The laws relate force and direction to all forms of motion.

In simple language, Newton's Laws of Motion:

First Law

Objects at rest remain at rest and objects in motion remain in motion in a straight line unless acted upon by an unbalanced force.

Second Law

Force equals mass times acceleration
($f = ma$).

Third Law

For every action there is an equal and opposite reaction.

Before looking at each of these laws in detail, a few terms should be explained.

Rest and Motion, as they are used in the first law, can be confusing. Both terms are relative. They mean rest or motion in relation to surroundings. You are at rest when sitting in a chair. It doesn't matter if the chair is in the cabin of a jet plane on a cross-country flight. You are still considered to be at rest because the airplane cabin is moving along with you. If you get up from your seat on the airplane and walk down the aisle, you are in relative motion because you are changing your position inside the cabin.

Force is a push or a pull exerted on an object. Force can be exerted in many ways, such as muscle power, movement of air, and electromagnetism, to name a few. In the case of rockets, force is usually exerted by burning rocket propellants that expand explosively.

Unbalanced Force refers to the sum total or net force exerted on an object. The forces on a coffee cup sitting on a desk, for example, are in balance. Gravity is exerting a downward force on the cup. At the same time, the structure of the desk exerts an upward force, preventing the cup from falling. The two forces are in balance. Reach over and pick up the cup. In doing so, you unbalance the forces on the cup. The weight you feel is the force of gravity acting on the mass of the cup. To move the cup upward, you have to exert a force greater than the force of gravity. If you hold the cup steady, the force of gravity and the muscle force you are exerting are in balance.

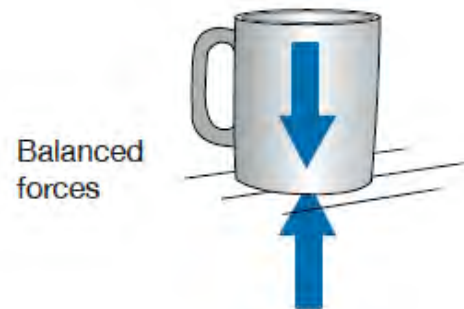
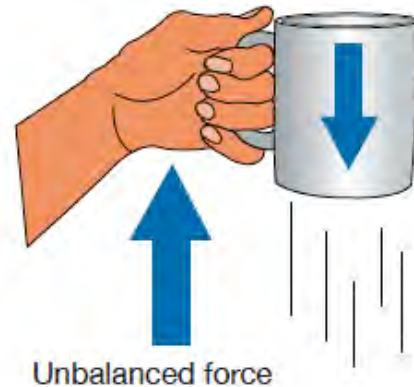

Unbalanced force also refers to other motions. The forces on a soccer ball at rest on the playing field are balanced. Give the ball a good kick, and the forces become unbalanced. Gradually, air drag (a force) slows the ball, and gravity causes it to bounce on the field. When the ball stops bouncing and rolling, the forces are in balance again. Take the soccer ball into deep space, far away from any star or other significant gravitational field, and give it a kick. The kick is an unbalanced force exerted on the ball that gets it moving. Once the ball is no longer in contact with the foot, the forces on the ball become balanced again, and the ball will travel in a straight line forever. How can you tell if forces are balanced or unbalanced? If the soccer ball is at rest, the forces are balanced. If the ball is moving at a constant speed and in a straight line, the forces are balanced. If the ball is accelerating or changing its direction, the forces are unbalanced.

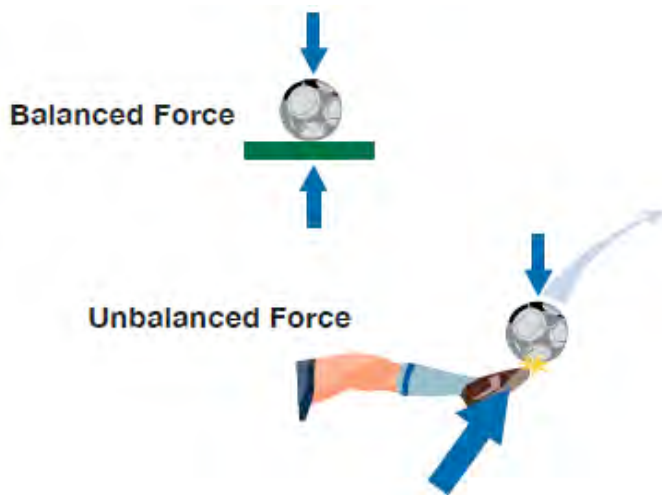

Mass is the amount of matter contained in an object. The object does not have to be solid. It could be the amount of air contained in a balloon or the amount of water in a glass. The important thing about mass is that unless you alter it in some way, it remains the same whether the object is on Earth, in Earth orbit, or on the Moon. Mass just refers to the quantity of matter contained in the object. (Mass and weight are often confused. They are not the same thing. Weight is a force and is the product of mass times the acceleration of gravity.)

Acceleration relates to motion. It means a change in motion. Usually, change refers to increasing speed, like what occurs when you

step on the accelerator pedal of a car. Acceleration also means changing direction.



This is what happens on a carousel. Even though the carousel is turning at a constant rate, the continual change in direction of the horses and riders (circular motion) is an acceleration.

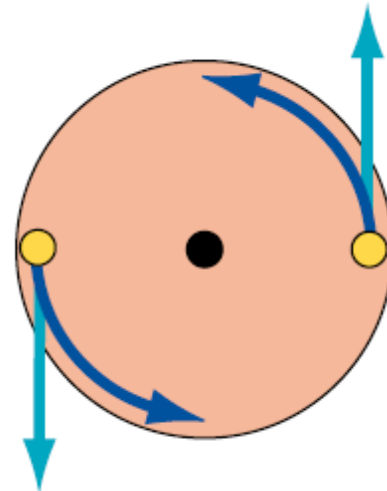

Top view of two riders on a carousel. The carousel platform exerts unbalanced forces on the riders, preventing them from going in straight lines. Instead, the platform continually accelerates the riders in a counterclockwise direction.

Action is the result of a force. A cannon fires, and the cannon ball flies through the air. The movement of the cannon ball is an action. Release air from an inflated balloon. The air shoots out the nozzle. That is also an action. Step off a boat onto a pier. That, too, is an action.

Reaction is related to action. When the cannon fires, and the cannon ball flies through the air, the cannon itself recoils backward. That is a reaction. When the air rushes out of the balloon, the balloon shoots the other way, another reaction. Stepping off a boat onto a pier causes a reaction. Unless the boat is held in some way, it moves in the opposite direction. (Note: The boat example is a great demonstration of the action/reaction principle, providing you are not the one stepping off the boat!)

Newton's First Law

This law is sometimes referred to as Galileo's law of inertia because Galileo discovered the principle of inertia. This law simply points out that an object at rest, such as a rocket on a launch pad, needs the exertion of an unbalanced force to cause it to lift off. The amount of the thrust (force) produced by the rocket engines has to be greater than the force of gravity holding it down. As long as the thrust of the engines continues, the rocket accelerates. When the rocket runs out of propellant, the forces become unbalanced again. This time, gravity takes over and causes the rocket to fall back to Earth. Following its "landing," the rocket is at rest again, and the forces are in balance. There is one very interesting part of this law that has enormous implications for spaceflight. When a rocket reaches space, atmospheric drag (friction) is greatly reduced or eliminated. Within the atmosphere, drag is an important unbalancing force. That force is virtually absent in space. A rocket traveling away from Earth at a speed greater than 11.186 kilometers per second (6.95 miles per second) or 40,270 kilometers per hour (25,023 mph) will eventually escape Earth's gravity. It will slow down, but Earth's gravity will never slow it down enough to cause it to fall back to Earth. Ultimately, the rocket (actually its payload) will travel to the stars. No additional rocket thrust will be needed. Its inertia will cause it to continue to travel outward. Four spacecraft are actually doing that as you read this. *Pioneers 10 and 11* and *Voyagers 1 and 2* are on journeys to the stars!

Newton's Third Law

(It is useful to jump to the third law and come back to the second law later.) This is the law of motion with which many people are familiar. It is the principle of action and reaction. In the case of rockets, the action is the force produced by the expulsion of gas, smoke, and flames from the nozzle end of a rocket engine. The reaction force propels the rocket in the opposite direction.

When a rocket lifts off, the combustion products from the burning propellants accelerate

rapidly out of the engine. The rocket, on the other hand, slowly accelerates skyward. It would appear that something is wrong here if the action and reaction are supposed to be equal. They are equal, but the mass of the gas, smoke, and flames being propelled by the engine is much less than the mass of the rocket being propelled in the opposite direction. Even though the force is equal on both, the effects are different.

Newton's first law, the law of inertia, explains why. The law states that it takes a force to change the motion of an object. The greater the mass, the greater the force required to move it.



Newton's Second Law

The second law relates force, acceleration, and mass. The law is often written as the equation:

$$f = m a$$

The force or thrust produced by a rocket engine is directly proportional to the mass of the gas and particles produced by burning rocket propellant times the acceleration of those combustion products out the back of the engine. This law only applies to what is actually traveling out of the engine at the moment and not the mass of the rocket propellant contained in the rocket that will be consumed later.

The implication of this law for rocketry is that the more propellant (m) you consume at any moment and the greater the acceleration (a) of the combustion products out of the nozzle, the greater the thrust (f)