

## ***Rocket Activity***

# **Launch Altitude Tracker**

### **Objective**

Using a simple altitude tracker and basic mathematics, students will indirectly measure the altitude achieved by the rockets they construct.

### **Description**

Determining the altitude reached by a rocket is a relatively simple process using a hand-held tracking device. The device is a sighting tube with a marked water level that permits measurement of the inclination of the tube. Using simple mathematics, students will calculate the altitude of the rocket. With two trackers in different locations, accuracy of the estimates can be improved.

### **Materials**

Tracker (see separate instructions)  
Tape measure  
Tangent table  
Data sheet  
Calculator (optional)

### **National Science Content Standards**

#### Physical Science

- Position and motion of objects
- Motions and forces

#### Science and Technology

- Understanding about science and technology

### **National Mathematics Content Standards**

- Number and Operations
- Geometry
- Measurement
- Data Analysis and Probability

### **National Mathematics Process Standards**

- Problem Solving
- Reasoning and Proof
- Communication
- Connections
- Representations

### **Management**

Altitude trackers are easy to construct. They are rugged and can be used again and again. Use them for altitude measurements with the High-Power Air Rockets and the Project X-51 activities. These rockets are capable of flights between 50 and 100 meters high. Be sure students understand how to sight rockets with the tracker. If you have a flagpole or tall building near the launch site, have students practice taking measurements of the angle between the ground and the top of the pole or to one of the upper corners of the building. When students are comfortable using the

tracker and consistent in measuring, they are ready to track rockets. Lay out a baseline from the launch site. Details for doing this are given in the procedures. A longer baseline provides better measurements than a shorter one. However, long baselines mean that your students will be spread out on the launch range. You may wish to enlist a teacher aid to help with supervision.

**Background:**

Altitude tracking of small rockets is an exciting activity for students because it provides them with a way of estimating how high their rocket flies. The technique for doing this is relatively simple. The rocket is launched and a tracker, some distance away, sights the rocket and determines the angle between the ground and the rocket at the top of its flight. Using a simple formula, the altitude is calculated.

a (altitude) = tangent of A (angle) X b (baseline)

$$a = \tan A (b)$$

To solve the formula, students look for the angle they measured on the tangent table. For example, the angle is 30 degrees. The tangent is 0.5774. They use that number in the equation. The baseline (distance from the launch pad to the tracker) is measured with a tape measure. In our example the distance is 25 meters.

$$a = 0.5774 \times 25 \text{ m} = 14.435 \text{ m}$$

The altitude reached by the rocket is 14.435 meters.

**Single station Tracking  
- No Wind**

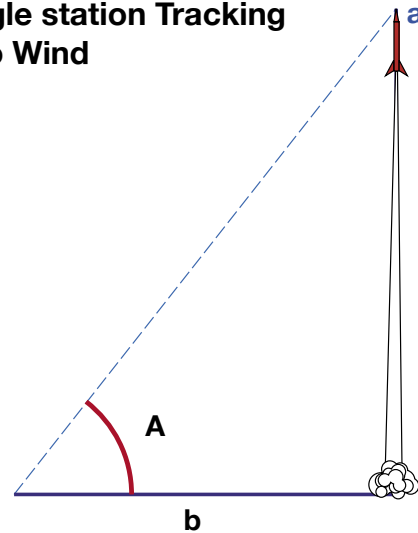

$$a = \tan A (b)$$

Angle	Tangent	Angle	Tangent
0	.0000	46	1.036
1	.0175	47	1.072
2	.0349	48	1.111
3	.0524	49	1.150
4	.0699	50	1.192
5	.0875	51	1.235
6	.1051	52	1.280
7	.1228	53	1.327
8	.1405	54	1.376
9	.1584	55	1.428
10	.1763	56	1.483
11	.1944	57	1.540
12	.2126	58	1.600
13	.2309	59	1.664
14	.2493	60	1.732
15	.2679	61	1.804
16	.2867	62	1.881
17	.3057	63	1.963
18	.3249	64	2.050
19	.3443	65	2.145
20	.3640	66	2.246
21	.3839	67	2.356
22	.4040	68	2.475
23	.4245	69	2.605
24	.4452	70	2.747
25	.4663	71	2.904
26	.4877	72	3.078
27	.5095	73	3.271
28	.5317	74	3.487
29	.5543	75	3.732
30	.5774	76	4.011
31	.6009	77	4.331
32	.6249	78	4.705
33	.6494	79	5.145
34	.6745	80	5.671
35	.7002	81	6.314
36	.7265	82	7.115
37	.7536	83	8.144
38	.7813	84	9.514
39	.8098	85	11.43
40	.8391	86	14.30
41	.8693	87	19.08
42	.9004	88	28.64
43	.9325	89	57.29
44	.9657	90	---
45	1.000	---	---

## Procedure: Making The Tracker:

1/2" PVC pipe (2 6"-long pieces, 1 12"-long piece)  
1/2" PVC tee connector  
1 10"-length of aquarium airline hose (clear vinyl)\*  
1 Straight Airline Connector\*  
Water and food coloring  
Permanent marker  
Marking Diagram  
\* Available at aquarium stores

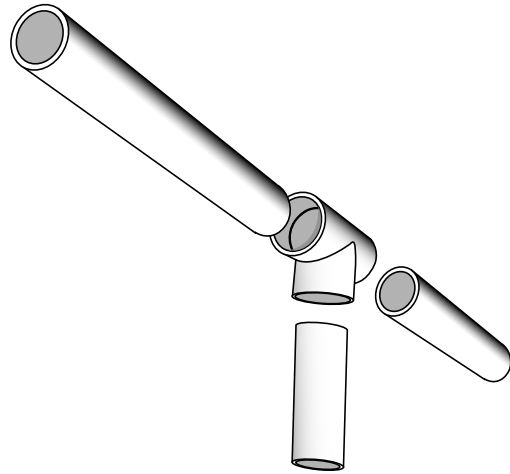

1. Fill one half of the aquarium hose with colored water and join the ends with the connector to form a ring.
2. Center the ring on the Marking Diagram and mark the hose starting at 0 degrees and going up to 90. Use a straight line for 10 degree intervals and dots for 5 degrees. Also mark the other 0 degree mark on the opposite side of the ring. It doesn't matter where the water is resting while you mark the ring. When the ring is mounted on the tracker, the water will settle horizontally.
3. Join the PVC pieces together as shown in the diagram.
4. Using clear tape, tape the ring vertically to the side of the PVC tee. The two 0 degree marks should line up with the sighting tube. The tracker is ready to be used.

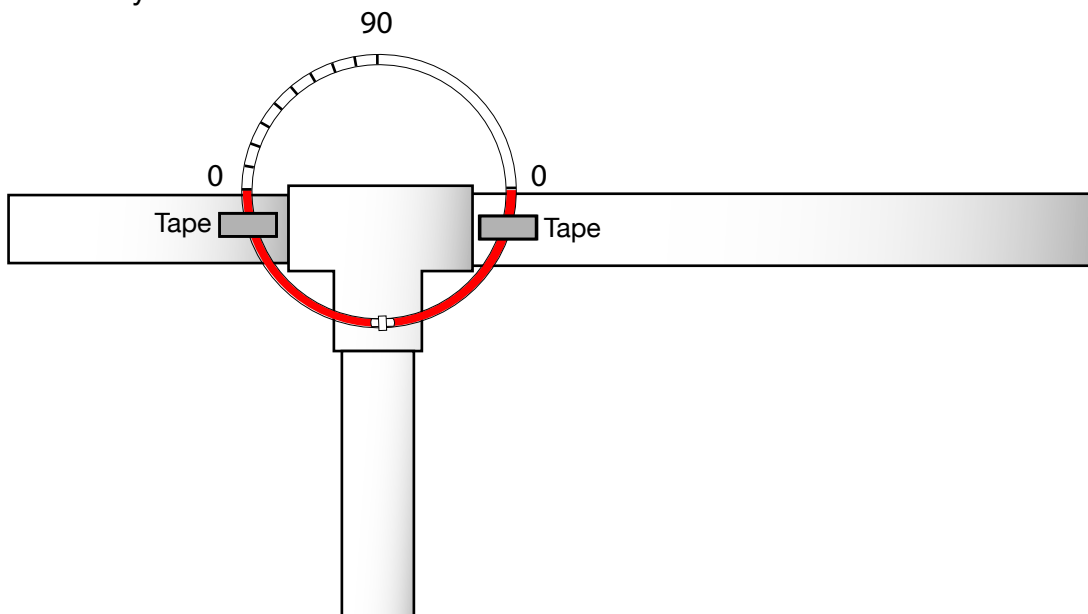
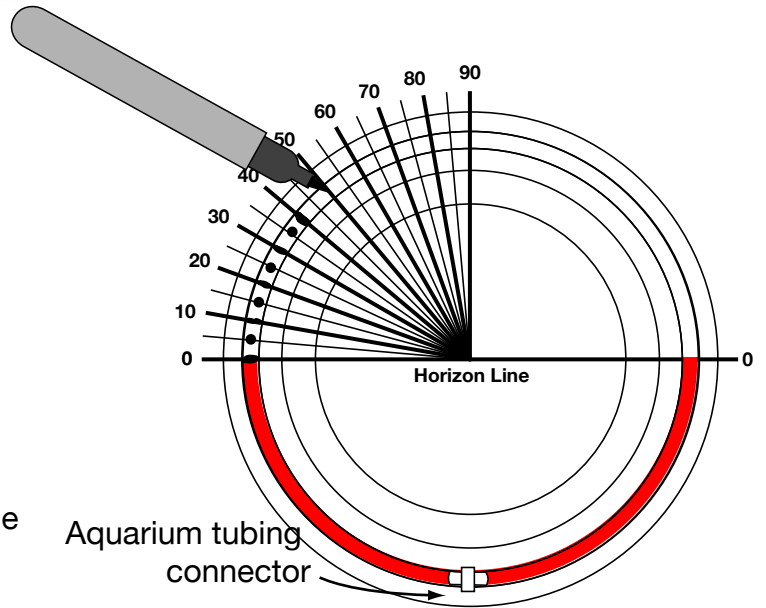

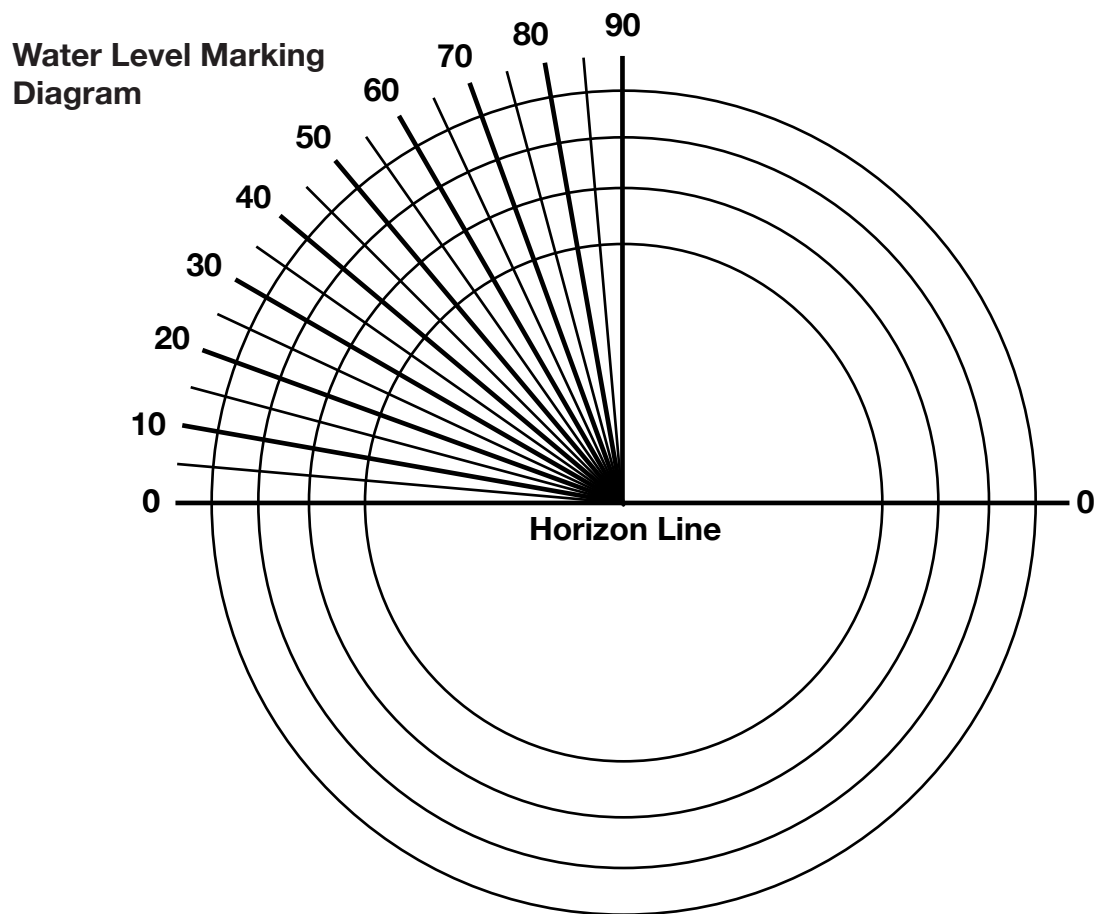

**Procedure** Using the Tracker

1. Select an open space for the launch. If the wind is strong, position the launch pad up wind so that the wind will blow the rocket on the field when it falls back.
2. Measure out the longest baseline you can conveniently have for the size of the launch field available. Align the baseline with the wind. (See note for using two tracking stations.)
3. Make sure the students at each station know which rocket is about to launch. When the rocket is launched, the tracking students aim their trackers at the highest point in the flight of the rocket. The angles of the trackers are read from the water level and the data recorded. Have the students help each other in reading the angle from the water level. For greater accuracy, have students average their estimates. Calculations can be done back in the classroom.

**Notes**

Assuming perfect conditions, the rocket goes straight up from the launch pad. This creates a right angle with Earth and the computed altitude should be accurate. However, altitude estimates for rockets that stray from the vertical will be less accurate. To minimize wind effects, two tracking stations can be used. Each are placed at equal distances from the launcher. The line connecting the two sites should be parallel to the wind. The students at each site track the rocket. Assuming the wind causes the rocket to drift over the up wind station, that tracker will get a higher angle than if the rocket had climbed straight up. The student at the down wind station will get a lower angle. Their estimates are averaged together to correct for wind effects. The diagram on the next page shows how the two tracking stations coordinate to improve altitude estimates.

As students compare estimates, errors will be detected. Their altitude estimates are only as accurate as the measurements of the angles. Precise angle measurements are difficult, especially when the rocket is small and the altitude is great. A disagreement of 10 percent in the estimated altitude between trackers is acceptable.

### Discussion

- *Why will a rocket angle into the wind during launch?*  
A crosswind will exert a force on the side of the rocket. Because of the fins, the lower end of the rocket has a greater surface area than the upper end. Like a weather vane, the rocket tends to nose into the wind and veer up wind.
- *Does the height of the person using the tracker have any effect on the measurement?*  
Yes. For the greatest accuracy in measuring, add the tracking student's eye height to the estimate of the rocket's altitude.
- *If the rocket drifts away from the baseline*

*before it reaches its maximum altitude does this affect the measurement?*

Yes. Two station tracking methods are available to correct for drift. In addition to the altitude angle measurement made at each station, the compass direction of the rocket's position also has to be measured. This greatly complicates the tracking procedure. Information about the process can be found on page 143.

### Assessment

- Review student participation in the activity and the completeness and accuracy of their altitude estimates.

### Extensions

- If there are any local chapters of rocketry clubs, invite a member in to demonstrate how model rocket and high-performance model rocket altitude is measured. (Many model rocketeers insert small electronic altimeters inside their rockets for direct altitude measurements.)

### Two-Station Tracking - Wind

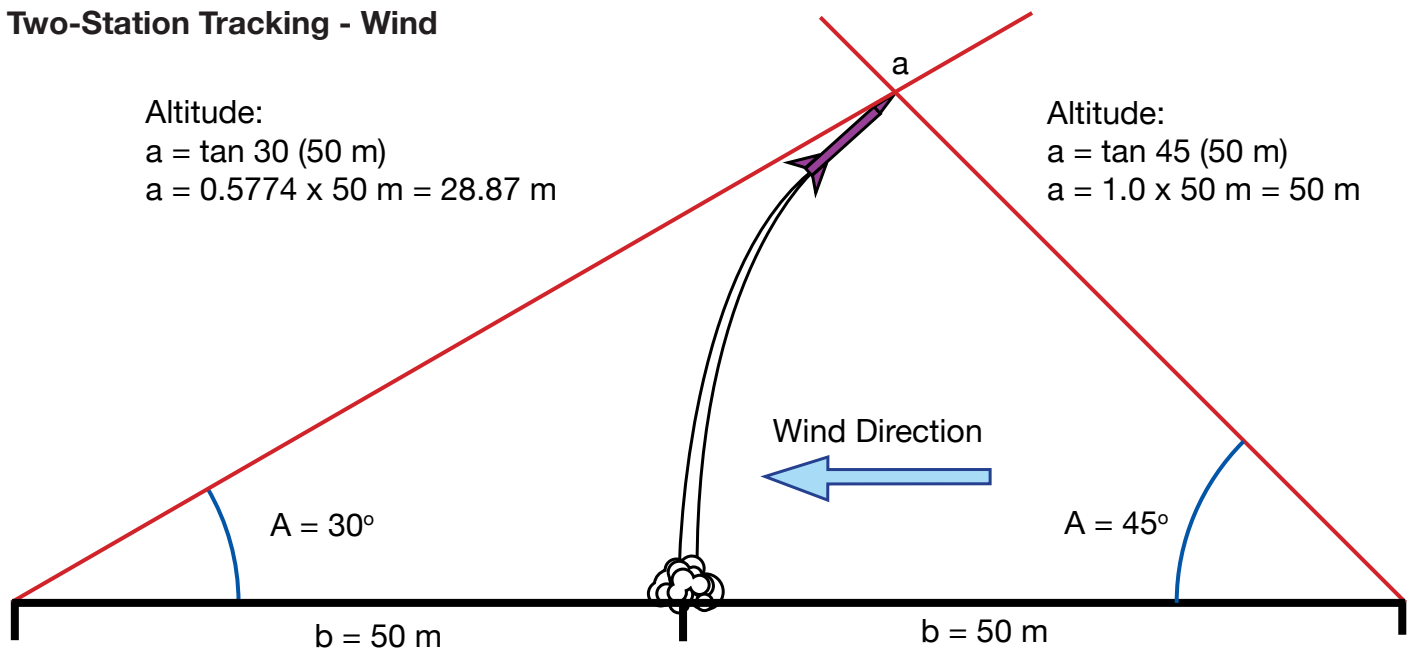

Average altitude for the two stations:

$$\frac{28.87 \text{ m} + 50 \text{ m}}{2} = 39.43 \text{ m}$$

# Altitude Tracking Data Sheet

Tracker Name: \_\_\_\_\_

Baseline Length: \_\_\_\_\_

1. Measure the angle to the highest point the rocket reaches.
2. Record the angle.
3. Look up the tangent for the angle.  
Record that number.
4. Multiply the tangent number times the length of the baseline. The answer is the altitude the rocket reached.

Rocket	Angle	Tangent	Altitude

Calculations:

Angle	Tangent	Angle	Tangent
0	.0000	46	1.036
1	.0175	47	1.072
2	.0349	48	1.111
3	.0524	49	1.150
4	.0699	50	1.192
5	.0875	51	1.235
6	.1051	52	1.280
7	.1228	53	1.327
8	.1405	54	1.376
9	.1584	55	1.428
10	.1763	56	1.483
11	.1944	57	1.540
12	.2126	58	1.600
13	.2309	59	1.664
14	.2493	60	1.732
15	.2679	61	1.804
16	.2867	62	1.881
17	.3057	63	1.963
18	.3249	64	2.050
19	.3443	65	2.145
20	.3640	66	2.246
21	.3839	67	2.356
22	.4040	68	2.475
23	.4245	69	2.605
24	.4452	70	2.747
25	.4663	71	2.904
26	.4877	72	3.078
27	.5095	73	3.271
28	.5317	74	3.487
29	.5543	75	3.732
30	.5774	76	4.011
31	.6009	77	4.331
32	.6249	78	4.705
33	.6494	79	5.145
34	.6745	80	5.671
35	.7002	81	6.314
36	.7265	82	7.115
37	.7536	83	8.144
38	.7813	84	9.514
39	.8098	85	11.43
40	.8391	86	14.30
41	.8693	87	19.08
42	.9004	88	28.64
43	.9325	89	57.29
44	.9657	90	---
45	1.000	---	---